

Shock Absorber

Soft type

Stops transported objects softly

Unique mechanism to achieve a variable sectional area of the fluid channel proportional to the stroke

Smooth absorption with a spiral groove structure

PAT.PEND

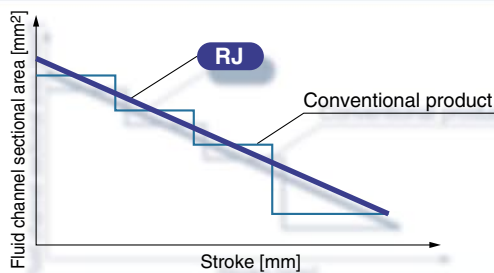

Suitable for softly stopping light objects or objects transferred at low speeds

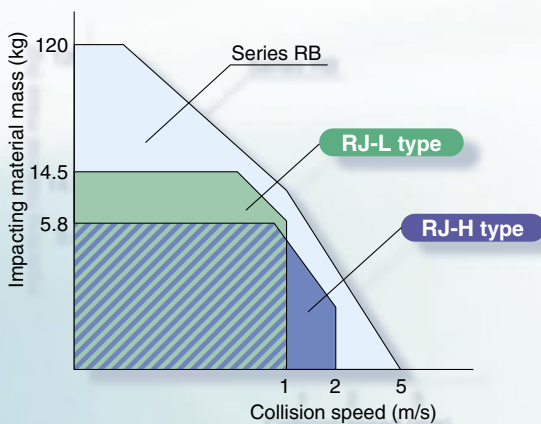

- Mounting interchangeable with the RB series.
- Variation available according to the operating speed.

Selectable from two types of collision speed range for each size

- **L type: 0.05 to 1 m/s**
- **H type: 0.05 to 2 m/s**

30% reduced absorption time

(compared with SMC RB series)

Shortened takt time of short stroke actuators, such as air slide tables and rotary tables

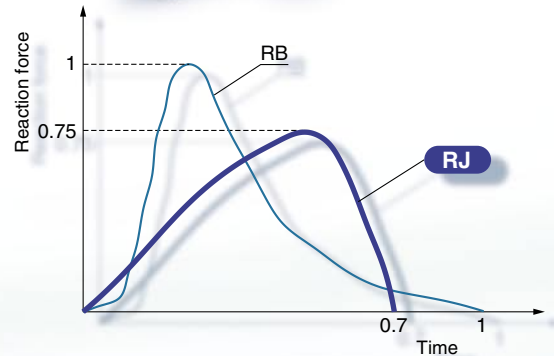

Series **RJ**



CAT.EUS20-200A-UK

Shock Absorber Series RJ Model Selection 1

Model Selection Graph

* The model selection graphs ① to ⑨ are at room temperature (20 to 25°C).

■ Type of Impact

Free horizontal impact

Impact of air cylinder actuation
(Horizontal/Upward)

Check the procedure "Model Selection Step"
from ① to ③ prior to use.

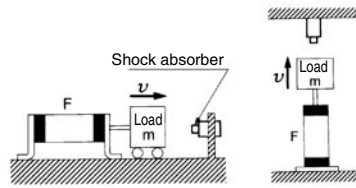

Graph ①/RJ0806

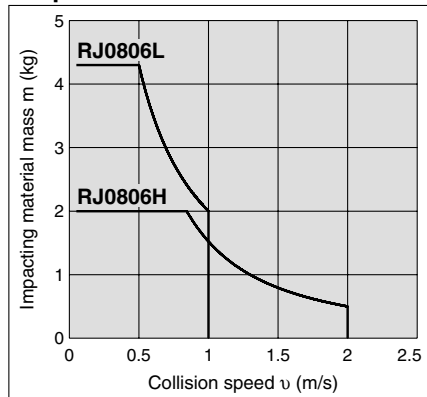

Graph ②/RJ1007

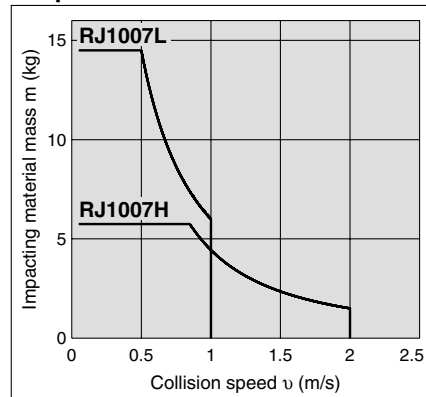

Graph ③/RJ1412

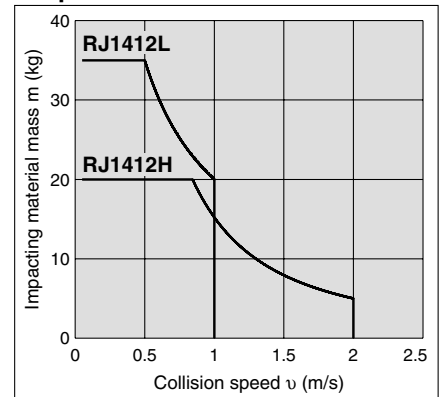

■ Type of Impact

Free fall impact

Impact of air cylinder actuation
(Downward)

Check the procedure "Model Selection Step"
from ① to ③ prior to use.

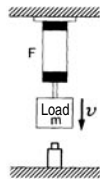

Graph ④/RJ0806

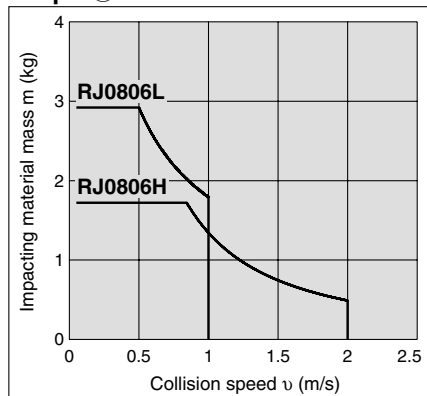

Graph ⑤/RJ1007

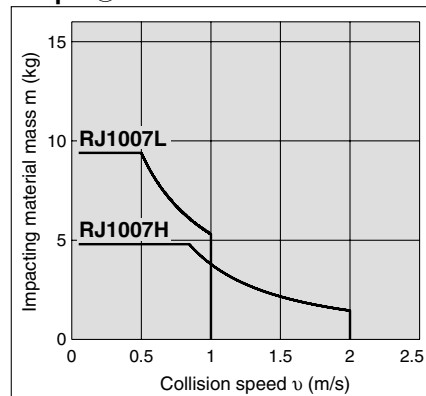

Graph ⑥/RJ1412

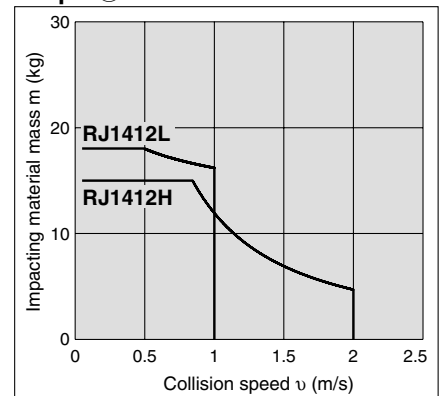

Model Selection Graph

* The model selection graphs ① to ⑨ are at room temperature (20 to 25°C).

■ Type of Impact

Others (such as thrust impact or swing impact other than air cylinder actuation)

Check the procedure "Model Selection Step" from ① to ⑦ to calculate equivalent mass M_e prior to use.

Graph ⑦/RJ0806

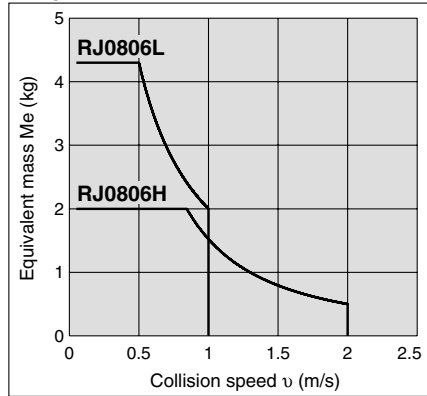

Graph ⑧/RJ1007

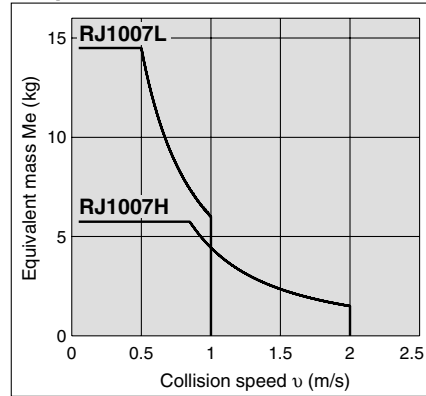

Graph ⑨/RJ1412

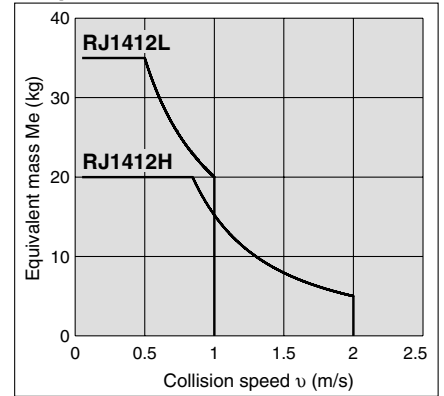

Shock Absorber Series RJ Model Selection 2

Model Selection

Model Selection Step

1 Type of impact

- Impact of thrust of load (Horizontal)
- Impact of thrust of load (Downward)
- Impact of thrust of load (Upward)
- Free horizontal impact (Impact of inertial force)
- Free fall impact
- Swing impact (With torque)

2 Operating conditions

Symbol	Operating conditions	Unit
m	Impacting material mass	kg
v	Collision speed	m/sec
h	Dropping height	m
ω	Angle speed	rad/sec
r	Distance between rotational centre and impact point	m
F	Thrust	N
T	Torque	N·m
n	Operating frequency	cycle/min
t	Ambient temperature	°C
μ	Friction coefficient	—

3 Confirmation of specifications and precautions

Ensure the **collision speed, thrust, operating frequency, ambient temperature and atmosphere** fall within the specifications.
* Be aware of the minimum installation radius in the case of swing impacts.

4 Calculation of kinetic energy E₁

Calculate kinetic energy E₁ by using the formula according to the impact type.

5 Calculation of thrust energy E₂

Calculate thrust energy E₂ by selecting a model temporarily.

6 Calculation of equivalent mass Me

Calculate absorbed energy E to confirm it is not more than the maximum absorbed energy of the temporarily selected shock absorber.

$$\text{Equivalent mass } M_e = \frac{2}{v^2} \cdot E$$

7 Selection of applicable model

Substitute the obtained equivalent mass Me, and the collision speed v by using "Model Selection Graph" ⑦ to ⑨ to check if the temporarily selected model is compatible with the condition of application. If satisfactory, then the temporarily selected model will be the applicable one.

Caution on Selection

In order for the shock absorbers to operate accurately for long hours, it is necessary to select a model that is well-suited to your operating conditions. If the impact energy is smaller than 5% of the maximum absorbed energy, select a model that is one class smaller.

Example of Selection

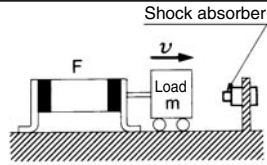
1 Type of impact	
<p>Impact of thrust of load (Horizontal) (Impact of thrust from sources other than air cylinder actuation)</p> 	
Collision speed ^{Note 1)} v	v
Kinetic energy E ₁	$\frac{1}{2} \cdot m \cdot v^2$
Thrust energy E ₂	F · S
Absorbed energy E	E ₁ + E ₂
Equivalent mass ^{Note 2)} Me	$\frac{2}{v^2} \cdot E$
2 Operating conditions	<p>m = 5 kg v = 0.5 m/s F = 150 N n = 30 cycle/min t = 25°C</p>
3 Confirmation of specifications and precautions	<p>● Confirmation of specifications v ... 0.5 < 1.0 (max.), 2.0 (max.) t ... -10 (min.) < 25 < 60 (max.) F ... 150 < 422 (max.)</p> <p style="text-align: center;">YES</p>
4 Calculation of kinetic energy E ₁	<p>● Kinetic energy E₁ Use [Formula] to calculate E₁ by using 5.0 for m and 0.5 for v.</p> <p style="text-align: center;">E₁ ≈ 0.63J</p>
5 Calculation of thrust energy E ₂	<p>● Thrust energy E₂ Select the RJ1007L temporarily and obtain E₂ by using the formula.</p> <p style="text-align: center;">E₂ ≈ 1.05J</p>
6 Calculation of equivalent mass Me	<p>● Equivalent mass Me Use [Formula] "Absorbed energy E = E₁ + E₂ = 0.63 + 1.05 = 1.68 J" to calculate Me by using E and 0.5 for v.</p> <p style="text-align: center;">Me ≈ 13.4 kg</p>
7 Check adequacy of the selected model RJ1007	<p>● Selection of applicable model According to Graph ⑧, the temporarily selected RJ1007L satisfies Me = 13.4 kg < 14.5 kg, resulting in an operating frequency of n = 30 < 70, without causing a problem.</p> <p style="text-align: center;">YES</p> <p style="text-align: center;">Select the RJ1007L.</p>

1 Type of Impact

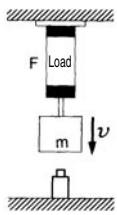
Type of impact	Impact of thrust of load (Downward) (Impact of thrust from sources other than air cylinder actuation)	Impact of thrust of load (Upward) (Impact of thrust from sources other than air cylinder actuation)	Load on conveyor (Horizontal)	Free fall impact	Swing impact (With torque)
		Load	Load	Load	Load
Collision speed v <small>Note 1)</small>	v	v	v	$\sqrt{2gh}$	$\omega \cdot R$
Kinetic energy E_1	$\frac{1}{2} \cdot m \cdot v^2$	$\frac{1}{2} \cdot m \cdot v^2$	$\frac{1}{2} \cdot m \cdot v^2$	$m \cdot g \cdot h$	$\frac{1}{2} \cdot I \cdot \omega^2$
Thrust energy E_2	$F \cdot S + m \cdot g \cdot S$	$F \cdot S - m \cdot g \cdot S$	$m \cdot g \cdot \mu \cdot S$	$m \cdot g \cdot S$	$T \cdot \frac{S}{R}$
Absorbed energy E	$E_1 + E_2$	$E_1 + E_2$	$E_1 + E_2$	$E_1 + E_2$	$E_1 + E_2$
Equivalent mass M_e <small>Note 2)</small>	$\frac{2}{v^2} \cdot E$	$\frac{2}{v^2} \cdot E$	$\frac{2}{v^2} \cdot E$	$\frac{2}{v^2} \cdot E$	$\frac{2}{v^2} \cdot E$

Note 1) This is the momentary speed at which an object is impacting against a shock absorber.

Note 2) This is the theoretical mass, which is converted into the mass of the impacting material under no thrust collision conditions. Hence, $E = \frac{1}{2} \cdot M_e \cdot v^2$

<Symbol>

Symbol	Specifications	Unit
E	Absorbed energy	J
E ₁	Kinetic energy	J
E ₂	Thrust energy	J
F	Thrust	N
g	Gravitational acceleration (9.8)	m/s ²
h	Dropping height	m
I <small>Note 3)</small>	Moment of inertia around the centre of gravity	kg·m ²
n	Operating frequency	cycle/min
R	Distance between rotational centre and impact point	m
S	Shock absorber's stroke	m
T	Torque	N·m
t	Ambient temperature	°C
v	Collision speed	m/s
m	Impacting material mass	kg
M _e	Equivalent mass	kg
ω	Angle speed	rad/s
μ	Friction coefficient	—

Note 3) For the formula for moment of inertia I (kg·m²), refer to the rotary actuator's catalogue.

Shock Absorber Series *RJ*



How to Order

RJ 0806 H

Shock absorber

Size

Symbol	O.D. thread	Stroke
0806	8 mm	6 mm
1007	10 mm	7 mm
1412	14 mm	12 mm

Option

Symbol	Hexagon nut	Stopper nut
—	2 pcs.	—
J	3 pcs.	—
N	—	—
S	2 pcs.	1 pc.
SJ	3 pcs.	1 pc.
SN	—	1 pc.

Collision speed range

H	0.05 to 2 m/s
L	0.05 to 1 m/s

Specifications

Model	RJ0806		RJ1007		RJ1412	
	H	L	H	L	H	L
Max. absorbed energy (J) ^{Note)}	1		3		10	
O.D. thread size (mm)	8		10		14	
Stroke (mm)	6		7		12	
Collision speed (m/s)	0.05 to 2	0.05 to 1	0.05 to 2	0.05 to 1	0.05 to 2	0.05 to 1
Max. operating frequency (cycle/min) ^{Note)}	80		70		45	
Spring force (N)	Extended	2.8	5.4	6.4		
	Retracted	5.4	8.4	17.4		
Max. allowable thrust (N)	245		422		814	
Ambient temperature (°C)	-10 to 60 (No freezing)					
Mass (g)	15		23		65	

Note) Max. absorbed energy and max. operating frequency values are at room temperature (20 to 25°C).

Construction

RJ0806

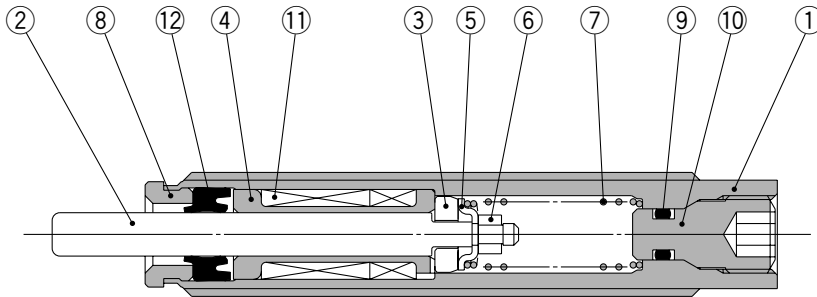

RJ1007, 1412

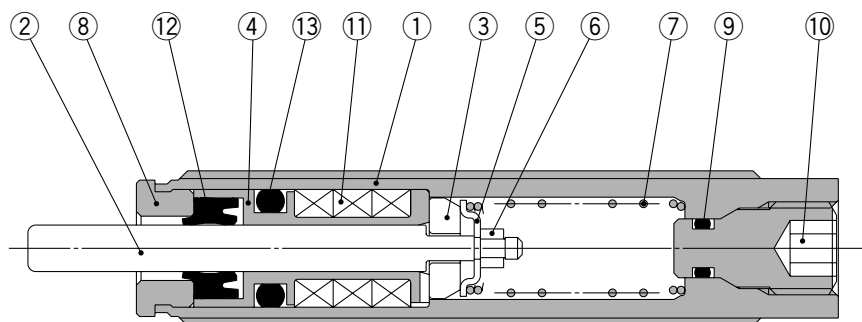

Component Parts

No.	Description	Material	Treatment
1	Tube	Special steel	Electroless nickel plated
2	Piston rod	Special steel	Electroless nickel plated
3	Piston	Stainless steel	
4	Bearing	Special bearing material	
5	Spring guide	Tool steel	Zinc chromated
6	Lock ring	Copper	
7	Return spring	Steel wire	Zinc chromated
8	Stopper	Structural steel	Electroless nickel plated
9	O-ring	Synthetic rubber	
10	Plug	—	H: Electroless nickel plated L: Black electroless nickel plated
11	Accumulator	Synthetic rubber	
12	Rod seal	Synthetic rubber	
13	O-ring	Synthetic rubber	

Dimensions

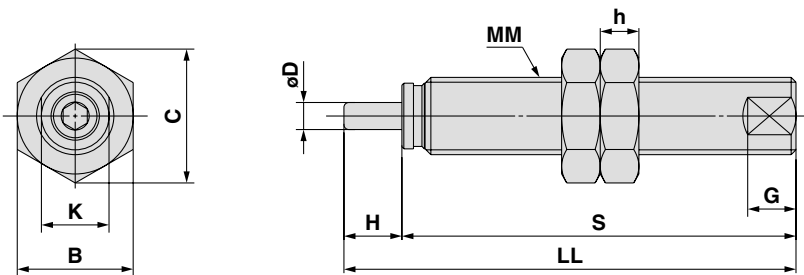

Model	Dimensions						Hexagon nut			
	D	H	LL	MM	S	G	K	B	C	h
RJ0806□	2.8	6	46.8	M8 x 1.0	40.8	5	7	12	13.9	4
RJ1007□	3	7	52.3	M10 x 1.0	45.3	7	9	14	16.2	4
RJ1412□	5	12	79.1	M14 x 1.5	67.1	8	12	19	21.9	6

* The dimensions of H- and L-type are the same.

Option

Basic type stopper nut

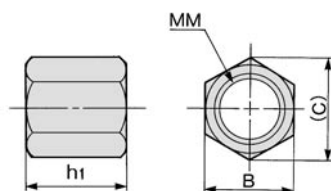

Model	Dimensions			
	B	C	h1	MM
Basic type				
RB08S	12	13.9	6.5	M8 x 1.0
RB10S	14	16.2	8	M10 x 1.0
RB14S	19	21.9	11	M14 x 1.5

Series RJ

Foot Bracket for Shock Absorber

Foot mounting bracket is available for the RJ series.

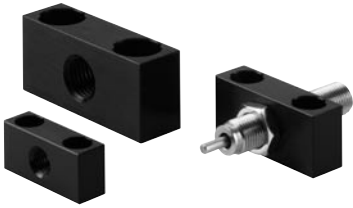

Part No.

Part no.	Applicable absorber
RB08-X331	RJ0806
RB10-X331	RJ1007
RB14-X331	RJ1412

* Order the foot bracket separately.

Dimensions

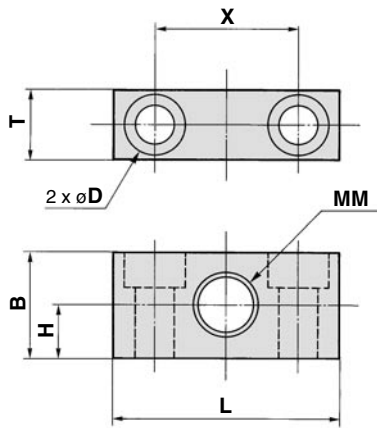

Model	B	D	H	L	MM	T	X	Mounting bolt
RB08-X331	15	4.5 drill, 8 counterbore depth 4.4	7.5	32	M8 x 1.0	10	20	M4
RB10-X331	19	5.5 drill, 9.5 counterbore depth 5.4	9.5	40	M10 x 1.0	12	25	M5
RB14-X331	25	9 drill, 14 counterbore depth 8.6	12.5	54	M14 x 1.5	16	34	M8





Safety Instructions

These safety instructions are intended to prevent hazardous situations and/or equipment damage. These instructions indicate the level of potential hazard with the labels of “**Caution**,” “**Warning**” or “**Danger**.” They are all important notes for safety and must be followed in addition to International Standards (ISO/IEC), Japan Industrial Standards (JIS)*1) and other safety regulations*2).

- * 1) ISO 4414: Pneumatic fluid power – General rules relating to systems.
ISO 4413: Hydraulic fluid power – General rules relating to systems.
IEC 60204-1: Safety of machinery – Electrical equipment of machines. (Part 1: General requirements)
ISO 10218-1992: Manipulating industrial robots -Safety.
JIS B 8370: General rules for pneumatic equipment.
JIS B 8361: General rules for hydraulic equipment.
JIS B 9960-1: Safety of machinery – Electrical equipment of machines. (Part 1: General requirements)
JIS B 8433-1993: Manipulating industrial robots - Safety.
etc.
- * 2) Labor Safety and Sanitation Law, etc.

 **Caution:** Operator error could result in injury or equipment damage.

 **Warning:** Operator error could result in serious injury or loss of life.

 **Danger :** In extreme conditions, there is a possibility of serious injury or loss of life.

Warning

1. The compatibility of the product is the responsibility of the person who designs the equipment or decides its specifications.

Since the product specified here is used under various operating conditions, its compatibility with specific equipment must be decided by the person who designs the equipment or decides its specifications based on necessary analysis and test results. The expected performance and safety assurance of the equipment will be the responsibility of the person who has determined its compatibility with the product. This person should also continuously review all specifications of the product referring to its latest catalogue information, with a view to giving due consideration to any possibility of equipment failure when configuring the equipment.

2. Only personnel with appropriate training should operate machinery and equipment.

The product specified here may become unsafe if handled incorrectly. The assembly, operation and maintenance of machines or equipment including our products must be performed by an operator who is appropriately trained and experienced.

3. Do not service or attempt to remove product and machinery/equipment until safety is confirmed.

1. The inspection and maintenance of machinery/equipment should only be performed after measures to prevent falling or runaway of the driven objects have been confirmed.

2. When the product is to be removed, confirm that the safety measures as mentioned above are implemented and the power from any appropriate source is cut, and read and understand the specific product precautions of all relevant products carefully.

3. Before machinery/equipment is restarted, take measures to prevent unexpected operation and malfunction.

4. Contact SMC beforehand and take special consideration of safety measures if the product is to be used in any of the following conditions.

1. Conditions and environments outside of the given specifications, or use outdoors or in a place exposed to direct sunlight.

2. Installation on equipment in conjunction with atomic energy, railways, air navigation, space, shipping, vehicles, military, medical treatment, combustion and recreation, or equipment in contact with food and beverages, emergency stop circuits, clutch and brake circuits in press applications, safety equipment or other applications unsuitable for the standard specifications described in the product catalogue.

3. An application which could have negative effects on people, property, or animals requiring special safety analysis.

4. Use in an interlock circuit, which requires the provision of double interlock for possible failure by using a mechanical protective function, and periodical checks to confirm proper operation.



Series RJ

Specific Product Precautions 1

Be sure to read this before handling. Refer to back page 1 for Safety Instructions, "Precautions for Handling Pneumatic Devices" (M-03-E3A) for Common Precautions.

Selection

Danger

1. Absorbed energy

Select a model so that the aggregated energy of an impacting material should not exceed the maximum absorbed energy. Otherwise, it could cause changes in properties or result in damaging the shock absorber.

2. Equivalent mass

Select a model so that the equivalent mass should not exceed the allowable range. Otherwise, pulsation could occur in buffer capacity and deceleration force, thus making it difficult to absorb shock smoothly.

3. Collision speed

Use the product within the specified collision speed range. Otherwise, it could cause the changes in buffer characteristics or result in damaging the shock absorber.

Warning

1. Static load

Design the system so that any other forces than the buffer capacity or impacts should not be applied to the piston rod which is stopped at the retracted state.

Caution

1. Maximum operating frequency

Design the system in the conditions under which it is not used at the frequency exceeding the specified maximum operating frequency.

2. Stroke

The specified maximum absorbed energy cannot be exerted unless the full stroke is used.

3. Work surface of an impacting material

The contact surface of an impacting material with which the piston rod comes into contact must be highly rigid. A high surface compression load is applied to the contact surface of the impacting material with which the piston rod comes into contact. Therefore, the contact surface must be highly rigid (hardness of HRC35 or more).

4. Be aware of the backlash of the impacting material.

When used in a conveyor line, the object may be pushed back by the built-in spring force after energy is absorbed. For backlash, refer to the spring force in the specifications. (page 5)

5. Selection of size

As the number of operation proceeds, the maximum absorbed energy of shock absorbers will be decreased by the reasons such as abrasion, or deterioration, etc. of the internal working fluid. Taking this into consideration, selecting a size which is 20 to 40% affordable against the amount of absorbed energy is recommended.

6. Reaction force

In general, the values of reaction force (reactive force generated during operation) generated by the operating speed will vary in oil hydraulic shock absorber. The RJ series can adapt to such this fast/slow speed and can absorb shock smoothly in a wide range of speed.

But, take note the stroke time could be long, and the motion would not be smooth, etc., depending on the operating conditions. If this would be a problem, we recommend the stroke amount should be restricted by using our optional component "stopper nut", etc.

Operating Environment

Danger

1. Operation in an environment which requires explosion-proof

- When mounting in places where static electricity is accumulated, implement a distribution of electrical energy by grounding.
- Do not use the materials for buffer face which might cause to spark by collision.

Warning

1. Pressure

Do not use the product in the vacuum state which is substantially different from the atmospheric pressure (above sea level) and in the atmosphere under being pressurized.

2. Using inside a clean room

Do not use the product in a clean room, as it could contaminate the clean room.

Caution

1. Temperature range

Do not use the product, exceeding the specified allowable temperature range. Seal could be softened or hardened or worn out, or leading to working fluid leak, deterioration, or buffer characteristic changes.

2. Deterioration by atmosphere

Do not use the product in the presence of salt damage, sulfurous acid gas which makes the metal corroded, or solvent which makes the seal deteriorated.

3. Deterioration by ozone

Do not use the product under the direct sunlight on the beach, or by the mercury lamp, or the ozone generator, because the rubber material will be deteriorated by ozone.

4. Cutting oil, water, blown dust

Do not use the product under the condition where the liquid such as cutting oil, water, solvent, etc. is exposed either directly or in atomized form to the piston rod, or where blown dust could be adhered around the piston rod. This could cause malfunction.

5. Vibration

When vibrations are applied on an impacting material, implement a secure guide on the impacting material.



Series RJ Specific Product Precautions 2

Be sure to read this before handling. Refer to back page 1 for Safety Instructions, "Precautions for Handling Pneumatic Devices" (M-03-E3A) for Common Precautions.

Mounting

Warning

- 1. Before performing installation, removal, or stroke adjustment, make sure to cut the power supply to the equipment and verify that the equipment has stopped.**
- 2. Installation of protective cover**
We recommend the protective cover should be installed for fear that workers might be getting close during the operation.
- 3. Strength of mounting frame**
The mounting frame needs to have sufficient strength. When deciding the strength of the mounting frame, consider the force applied to the mounting frame at the upper limit of operating conditions shown in the below table, and allow a sufficient safety factor.

Model	Load on mounting frame
RJ0806	630 N
RJ1007	1600 N
RJ1412	2000 N

(Note) Load on mounting frame is at room temperature (20 to 25°C).

Caution

1. Tightening torque and mounting thread

When threading on the mounting frame in order to mount a shock absorber directly, refer to the below prepared hole dimensions. Observe the below tightening torque of a nut for shock absorber.
If the tightening torque exceeds the below value, the shock absorber could be damaged.

Model	RJ0806	RJ1007	RJ1412
Thread dimensions (mm)	M8 x 1.0	M10 x 1.0	M14 x 1.5
Thread prepared hole dia. (mm)	$\phi 7.1 \begin{smallmatrix} +0.1 \\ 0 \end{smallmatrix}$	$\phi 9.1 \begin{smallmatrix} +0.1 \\ 0 \end{smallmatrix}$	$\phi 12.7 \begin{smallmatrix} +0.1 \\ 0 \end{smallmatrix}$
Nut tightening torque (N·m)	1.67	3.14	10.8

2. Deviation of impact

Mount the shock absorber so that the point of contact of an impacting material must be within the allowable eccentric angle range. If the eccentric angle exceed 3° , an excessive load could be placed on the bearings, resulting in oil leak in a short time.

Allowable eccentric angle $\theta_1 < 3^\circ$

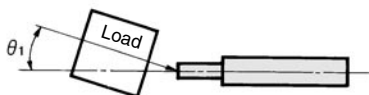

Caution

3. Rotating angle

If swing impacts are involved, the installation must be designed so that the direction in which a load is applied should be perpendicular to the shock absorber's axial centre.
The allowable rotating eccentric angle to the stroke end must be $\theta_2 < 3^\circ$.

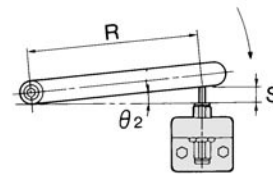

Allowable rotating eccentric angle $\theta_2 < 3^\circ$

Installation Requirement for Swing Impacts (mm)

Model	S (Stroke)	θ_2 (Allowable rotating angle)	R (Min. installation radius)
RJ0806	6	3°	115
RJ1007	7		134
RJ1412	12		229

4. Do not scratch the sliding portion of the piston rod or the outside threads of the outer tube.

Failure to observe this precaution could scratch or gouge the sliding portion of the piston rod, or damage the seals, resulting in oil leak or malfunction. Furthermore, damage to outside threaded portion of the outer tube could prevent the shock absorber from being mounted onto the frame, or result in malfunction by internal component parts deformation.

5. Never turn the screw on the bottom of the body.

This is not an adjusting screw. Otherwise, oil leak could occur.

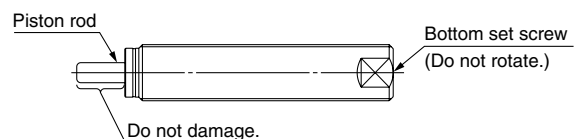

6. Adjust the stopping time by using a stopper nut.

Control the stopping time of the impacting material by turning the stopper nut in or out (thus changing length "a"). After establishing the stopper nut position, use a hexagon nut to secure the stopper nut in place.

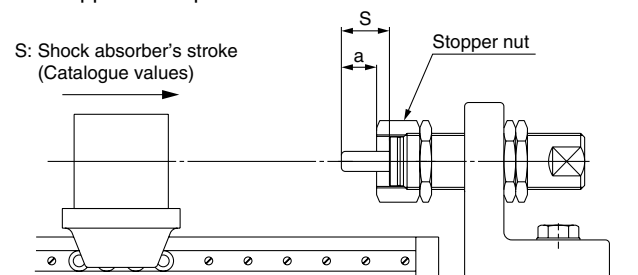



Series RJ Specific Product Precautions 3

Be sure to read this before handling. Refer to back page 1 for Safety Instructions, "Precautions for Handling Pneumatic Devices" (M-03-E3A) for Common Precautions.

Maintenance

⚠ Caution

1. Confirm that the mounting nut is not loosen.

The shock absorber could be damaged if used in a loosen state.

2. Pay attention to any abnormal impact sounds or vibrations.

If impact sounds or vibrations become abnormally high, the shock absorber may reach the end of its service life. Replace the shock absorber. If using continuously in such a state, equipment could be damaged.

3. Confirm that there is no oil leak on the outer surface.

When a large amount of oil is leaking, replace the product, because it is believed to be happening something wrong with it. If using continuously in such a state, equipment could be damaged.

Storage

⚠ Caution

1. Position of the piston rod during storage

If the product is stored for an extended period (30 days or more) with the piston rod pushed, the absorption capacity could decrease. Avoid this kind of storage condition.

Life and Replacement Period of Product

⚠ Caution

1. As a guide, the maximum operating life of the product (number of cycles) when operated within the specifications is as follows.

3 million cycles RJ0806, 1007, 1412

Note) This value (adequate replacement period) is at room temperature (20 to 25°C). The life can depend on conditions such as temperature so the product may need to be replaced before the above number of cycles is reached.

SMC CORPORATION (Europe)

Austria	☎ +43 2262622800	www.smc.at	office@smc.at
Belgium	☎ +32 (0)33551464	www.smc-pneumatics.be	info@smc-pneumatics.be
Bulgaria	☎ +359 29744492	www.smc.bg	office@smc.bg
Croatia	☎ +385 1377 66 74	www.smc.hr	office@smc.hr
Czech Republic	☎ +42 0541424611	www.smc.cz	office@smc.cz
Denmark	☎ +45 70252900	www.smc.dk	smc@smc.dk
Estonia	☎ +372 6510370	www.smc-pneumatics.ee	smc@smc-pneumatics.ee
Finland	☎ +358 207513513	www.smc.fi	smc.fi@smc.fi
France	☎ +33 (0)164761000	www.smc-france.fr	contact@smc-france.fr
Germany	☎ +49 (0)61034020	www.smc-pneumatik.de	info@smc-pneumatik.de
Greece	☎ +30 2102717265	www.smc-hellas.gr	sales@smc-hellas.gr
Hungary	☎ +36 23511390	www.smc.hu	office@smc.hu
Ireland	☎ +353 (0)14039000	www.smc-pneumatics.ie	sales@smc-pneumatics.ie
Italy	☎ +39 (0)292711	www.smc-italia.it	mailbox@smc-italia.it
Latvia	☎ +371 7817700	www.smc.lv	info@smc.lv
Lithuania	☎ +370 52648126		
Netherlands	☎ +31 (0)205318888	www.smc-pneumatics.nl	info@smc-pneumatics.nl
Norway	☎ +47 67129020	www.smc-norge.no	post@smc-norge.no
Poland	☎ +48 222119600	www.smc.pl	office@smc.pl
Portugal	☎ +351 226166570	www.smc.eu	postpt@smc-smces.es
Romania	☎ +40 213205111	www.smc-romania.ro	smcromania@smcromania.ro
Russia	☎ +7 812 1185445	www.smc-pneumatik.ru	info@smc-pneumatik.ru
Slovakia	☎ +421 413213212	www.smc.sk	office@smc.sk
Slovenia	☎ +386 73885412	www.smc.si	office@smc.si
Spain	☎ +34 945184100	www.smc.eu	post@smc-smces.es
Sweden	☎ +46 (0)86031200	www.smc.nu	post@smc-pneumatics.se
Switzerland	☎ +41 (0)523963131	www.smc.ch	info@smc.ch
Turkey	☎ +90 (0)2124440762	www.entek.com.tr	smc@entek.com.tr
UK	☎ +44 (0)8001382930	www.smc-pneumatics.co.uk	sales@smc-pneumatics.co.uk

European Marketing Centre ☎ +34 945184100
SMC CORPORATION ☎ +81 0335022740

www.smc.eu
www.smcworld.com

SMC CORPORATION Akihabara UDX 15F, 4-14-1, Sotokanda, Chiyoda-ku, Tokyo 101-0021, JAPAN Phone: 03-5207-8249 FAX: 03-5298-5362