



# Operation Manual

PRODUCT NAME

SI unit for DeviceNet™

MODEL / Series / Product Number

*EX180-SDN3/4/5/6□ Series*

**SMC Corporation**



# Contents

Safety Instructions	2
How to Order	7
Summary of Product Parts	8
Installation and Cabling	9
General Instructions on Installation	9
Connecting Cables	10
LED Display and Settings	12
DeviceNet™ Objects	15
Troubleshooting and Maintenance	24
Maintenance	29
Specifications	30
Table of Specifications	30
Dimensions	32

## Safety Instructions

These safety instructions are intended to prevent hazardous situations and/or equipment damage. These instructions indicate the level of potential hazard with the labels of "Caution", "Warning" or "Danger". They are all important notes for safety and must be followed in addition to International standards (ISO/IEC) \*1) and other safety regulations.

- \*1) ISO 4414: Pneumatic fluid power -- General rules relating to systems.
- ISO 4413: Hydraulic fluid power -- General rules relating to systems.
- IEC 60204-1: Safety of machinery -- Electrical equipment of machines. (Part 1: General requirements)
- ISO 10218-1992: Manipulating industrial robots -Safety.
- etc.

 <b>Caution</b> :	CAUTION indicates a hazard with a low level of risk which, if not avoided, could result in minor or moderate injury.
 <b>Warning</b> :	WARNING indicates a hazard with a medium level of risk which, if not avoided, could result in death or serious injury.
 <b>Danger</b> :	DANGER indicates a hazard with a high level of risk which, if not avoided, will result in death or serious injury.

### **Warning**

**1. The compatibility of the product is the responsibility of the person who designs the equipment or decides its specifications.**

Since the product specified here is used under various operating conditions, its compatibility with specific equipment must be decided by the person who designs the equipment or decides its specifications based on necessary analysis and test results. The expected performance and safety assurance of the equipment will be the responsibility of the person who has determined its compatibility with the product. This person should also continuously review all specifications of the product referring to its latest catalog information, with a view to giving due consideration to any possibility of equipment failure when configuring the equipment.

**2. Only personnel with appropriate training should operate machinery and equipment.**

The product specified here may become unsafe if handled incorrectly. The assembly, operation and maintenance of machines or equipment including our products must be performed by an operator who is appropriately trained and experienced.

**3. Do not service or attempt to remove product and machinery/equipment until safety is confirmed.**

1. The inspection and maintenance of machinery/equipment should only be performed after measures to prevent falling or runaway of the driven objects have been confirmed.
2. When the product is to be removed, confirm that the safety measures as mentioned above are implemented and the power from any appropriate source is cut, and read and understand the specific product precautions of all relevant products carefully.
3. Before machinery/equipment is restarted, take measures to prevent unexpected operation and malfunction.

**4. Contact SMC beforehand and take special consideration of safety measures if the product is to be used in any of the following conditions.**

1. Conditions and environments outside of the given specifications, or use outdoors or in a place exposed to direct sunlight.
2. Installation on equipment in conjunction with atomic energy, railways, air navigation, space, shipping, vehicles, military, medical treatment, combustion and recreation, or equipment in contact with food and beverages, emergency stop circuits, clutch and brake circuits in press applications, safety equipment or other applications unsuitable for the standard specifications described in the product catalog.
3. An application which could have negative effects on people, property, or animals requiring special safety analysis.
4. Use in an interlock circuit, which requires the provision of double interlock for possible failure by using a mechanical protective function, and periodical checks to confirm proper operation.

## **Caution**

### **The product is provided for use in manufacturing industries.**

The product herein described is basically provided for peaceful use in manufacturing industries. If considering using the product in other industries, consult SMC beforehand and exchange specifications or a contract if necessary.  
If anything is unclear, contact your nearest sales branch.

## **Limited warranty and Disclaimer/Compliance Requirements**

The product used is subject to the following "Limited warranty and Disclaimer" and "Compliance Requirements".

Read and accept them before using the product.

### **Limited warranty and Disclaimer**

1. The warranty period of the product is 1 year in service or 1.5 years after the product is delivered. \*2)  
Also, the product may have specified durability, running distance or replacement parts. Please consult your nearest sales branch.
2. For any failure or damage reported within the warranty period which is clearly our responsibility, a replacement product or necessary parts will be provided.  
This limited warranty applies only to our product independently, and not to any other damage incurred due to the failure of the product.
3. Prior to using SMC products, please read and understand the warranty terms and disclaimers noted in the specified catalog for the particular products.

\*2) Vacuum pads are excluded from this 1 year warranty.

A vacuum pad is a consumable part, so it is warranted for a year after it is delivered.

Also, even within the warranty period, the wear of a product due to the use of the vacuum pad or failure due to the deterioration of rubber material are not covered by the limited warranty.

### **Compliance Requirements**

1. The use of SMC products with production equipment for the manufacture of weapons of mass destruction (WMD) or any other weapon is strictly prohibited.
2. The exports of SMC products or technology from one country to another are governed by the relevant security laws and regulation of the countries involved in the transaction. Prior to the shipment of a SMC product to another country, assure that all local rules governing that export are known and followed.

## Operator

- ◆ This operation manual is intended for those who have knowledge of machinery using pneumatic equipment, and have sufficient knowledge of assembly, operation and maintenance of such equipment. Only those persons are allowed to perform assembly, operation and maintenance.
- ◆ Read and understand this operation manual carefully before assembling, operating or providing maintenance to the product.

### ■ Safety Instructions

#### **Warning**

- Do not disassemble, modify (including changing the printed circuit board) or repair.  
An injury or failure can result.
- Do not operate the product outside of the specifications.  
Do not use for flammable or harmful fluids.  
Fire, malfunction, or damage to the product can result.  
Verify the specifications before use.
- Do not operate in an atmosphere containing flammable or explosive gases.  
Fire or an explosion can result.  
This product is not designed to be explosion proof.
- If using the product in an interlocking circuit:
  - Provide a double interlocking system, for example a mechanical system.
  - Check the product regularly for proper operation.Otherwise malfunction can result, causing an accident.
- The following instructions must be followed during maintenance:
  - Turn off the power supply.
  - Stop the air supply, exhaust the residual pressure and verify that the air is released before performing maintenance.Otherwise an injury can result.

#### **Caution**

- After maintenance is complete, perform appropriate functional inspections.  
Stop operation if the equipment does not function properly.  
Safety cannot be assured in the case of unexpected malfunction.
- Provide grounding to assure the safety and noise resistance of the Fieldbus system.  
Individual grounding should be provided close to the product with a short cable.



## ■NOTE

○Follow the instructions given below when designing, selecting and handling the product.

●The instructions on design and selection (installation, wiring, environment, adjustment, operation, maintenance, etc.) described below must also be followed.

\*Product specifications

●When conformity to UL is necessary the SI unit must be used with a UL1310 Class2 power supply.

●The SI unit is a  approved product only if they have a  mark on the body.

●Use the specified voltage.

Otherwise failure or malfunction can result.

●Reserve a space for maintenance.

Allow sufficient space for maintenance when designing the system.

●Do not remove any nameplates or labels.

This can lead to incorrect maintenance, or misreading of the operation manual, which could cause damage or malfunction to the product.

It may also result in non-conformity to safety standards.

●Product handling

\*Installation

●Do not drop, hit or apply excessive shock to the fieldbus system.

Otherwise damage to the product can result, causing malfunction.

●Tighten to the specified tightening torque.

If the tightening torque is exceeded the mounting screws may be broken.

●Never mount a product in a location that will be used as a foothold.

The product may be damaged if excessive force is applied by stepping or climbing onto it.

\*Wiring

●Avoid repeatedly bending or stretching the cables, or placing heavy load on them.

Repetitive bending stress or tensile stress can cause breakage of the cable.

●Wire correctly.

Incorrect wiring can break the product.

●Do not perform wiring while the power is on.

Otherwise damage to the fieldbus system and/or I/O device can result, causing malfunction.

●Do not route wires and cables together with power or high voltage cables.

Otherwise the fieldbus system and/or I/O device can malfunction due to interference of noise and surge voltage from power and high voltage cables to the signal line.

Route the wires (piping) of the fieldbus system and/or I/O device separately from power or high voltage cables.

●Confirm proper insulation of wiring.

Poor insulation (interference from another circuit, poor insulation between terminals, etc.) can lead to excess voltage or current being applied to the product, causing damage.

●Take appropriate measures against noise, such as using a noise filter, when the fieldbus system is incorporated into equipment.

Otherwise noise can cause malfunction.

#### \*Environment

- Do not use the product in area that is exposed to corrosive gases, chemicals, sea water, water or steam.  
Otherwise failure or malfunction can result.
- Do not use in an area where surges are generated.  
If there is equipment which generates a large amount of surge (solenoid type lifter, high frequency induction furnace, motor, etc.) close to the fieldbus system, this may cause deterioration or breakage of the internal circuit of the fieldbus system. Avoid sources of surge generation and crossed lines.
- When a surge-generating load such as a relay or solenoid is driven directly, use an fieldbus system with a built-in surge absorbing element.  
Direct drive of a load generating surge voltage can damage the fieldbus system.
- The product is CE marked, but not immune to lightning strikes. Take measures against lightning strikes in the system.
- Prevent foreign matter such as remnant of wires from entering the fieldbus system to avoid failure and malfunction.
- Mount the product in a place that is not exposed to vibration or impact.  
Otherwise failure or malfunction can result.
- Do not use the product in an environment that is exposed to temperature cycle.  
Heat cycles other than ordinary changes in temperature can adversely affect the inside of the product.
- Do not expose the product to direct sunlight.  
If using in a location directly exposed to sunlight, shade the product from the sunlight.  
Otherwise failure or malfunction can result.
- Keep within the specified ambient temperature range.  
Otherwise malfunction can result.
- Do not operate close to a heat source, or in a location exposed to radiant heat.  
Otherwise malfunction can result.

#### \*Adjustment and Operation

- Set the switches by using a sharp-pointed screwdriver etc.  
It may damage set switches.
- Perform settings suitable for the operating conditions.  
Incorrect setting can cause operation failure.  
For details of each setting, refer to page 13 of this manual.
- Please refer to the PLC manufacturer's manual etc. for details of programming and addresses.  
For the PLC protocol and programming refer to the relevant manufacturer's documentation.

#### \*Maintenance

- Turn off the power supply, stop the supplied air, exhaust the residual pressure and verify the release of air before performing maintenance.  
There is a risk of unexpected malfunction.
- Perform regular maintenance and inspections.  
There is a risk of unexpected malfunction.
- After maintenance is complete, perform appropriate functional inspections.  
Stop operation if the equipment does not function properly.  
Otherwise safety is not assured due to an unexpected malfunction or incorrect operation.
- Do not use solvents such as benzene, thinner etc. to clean the each unit.  
They could damage the surface of the body and erase the markings on the body.  
Use a soft cloth to remove stains.  
For heavy stains, use a cloth soaked with diluted neutral detergent and fully squeezed, then wipe up the stains again with a dry cloth.

## How to Order

- EX180 series SI unit

EX180-S DN □

- Communication connector specifications

Nil	T branch type
A	Straight type

- Network, number of outputs, output type

DN3	Applicable for DeviceNet™, 32 outputs, NPN output (positive common)
DN4	Applicable for DeviceNet™, 16 outputs, NPN output (positive common)
DN5	Applicable for DeviceNet™, 32 outputs, PNP output (negative common)
DN6	Applicable for DeviceNet™, 16 outputs, PNP output (negative common)

- Accessories: Communication connector

EX180-C DN □

- Communication connector specifications

1	T branch type
2	Straight type

- Network

DN	Applicable for DeviceNet™
----	---------------------------

- Accessories: Power supply connector

EX180-CP1

## Summary of Product Parts

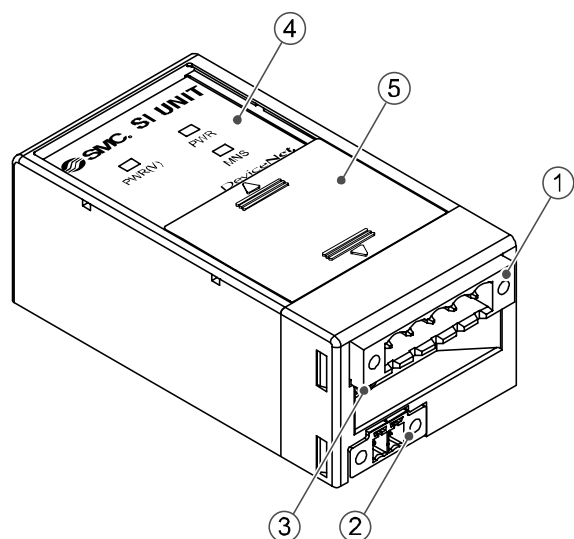

Communication connector for DeviceNet™ (1 pc.)  
EX180-SDN3/4/5/6      EX180-SDN3A/4A/5A/6A

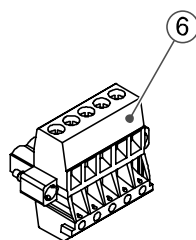

(EX180-CDN1)

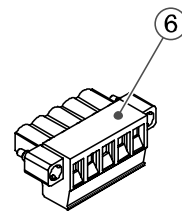

(EX180-CDN2)

Power supply connector (1 pc.)

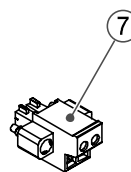

(EX180-CP1)

### Accessories

No.	Element	Description
1	Fieldbus interface connector (BUS)	The connector for DeviceNet™ (⑥) that is used to connect to the DeviceNet™ bus line.
2	Socket for the power supply (PWR(V))	The connector for the power supply (⑦) that is used to supply the power for the solenoid valves.
3	FG terminal	Functional Earth.
4	Display	LED diagnostic display.
5	Switch setting part	Configures the MAC ID/communication speed.

# Installation and Cabling

## ■ General Instructions on Installation

### ○ Applicable valve series

The EX180 series SI unit can be mounted on the following valve manifolds.

#### ● Manifolds

SJ2000, SJ3000, S0700 series

\*: Refer to the catalogues and operation manuals for details on the solenoid valves and manifolds.

#### ● How to mount the manifold

1. Mount the SI unit to the manifold so that the mounting guide of the SI unit case mates with the manifold groove.
2. Secure the SI unit using the two sliding locks.

①

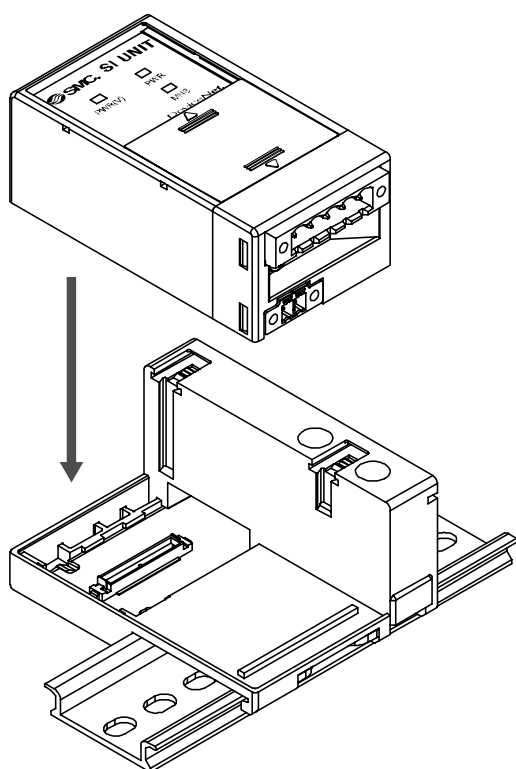

②

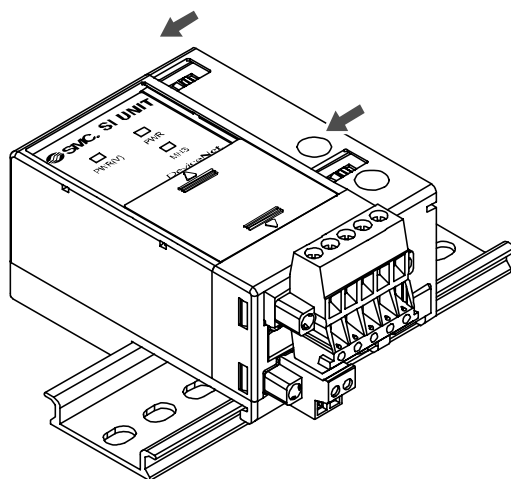

#### ● Caution

The EX180-SDN1□/2□ can not mount on the valve manifold for the EX180-SDN3□/4□/5□/6□.

The EX180-SDN3□/4□/5□/6□ also can not mount on the valve manifold for the EX180-SDN1□/2□.

## ■ Connecting Cables

### 1. Wiring for communication

Wiring of the DeviceNet™ cable and communication connector is shown below.

(1) Connect the signal lines to the assigned pins. (Figure 1)

The DeviceNet™ communication connector is suitable for use with wire sizes from AWG24 to 12 (0.2 mm<sup>2</sup> to 2.5 mm<sup>2</sup>).

The required tightening torque is 0.5 to 0.6 Nm.

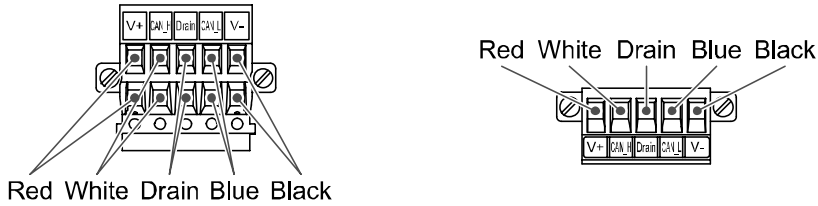

Figure 1

(2) A bus termination is required at both ends of DeviceNet™ bus segment as shown in the Figure 2. The specification of the terminating resistor is 121 Ω ±1%, 1/4 W.

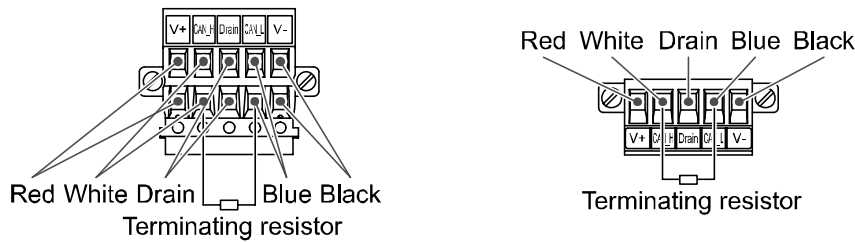

Figure 2

(3) How to connect.

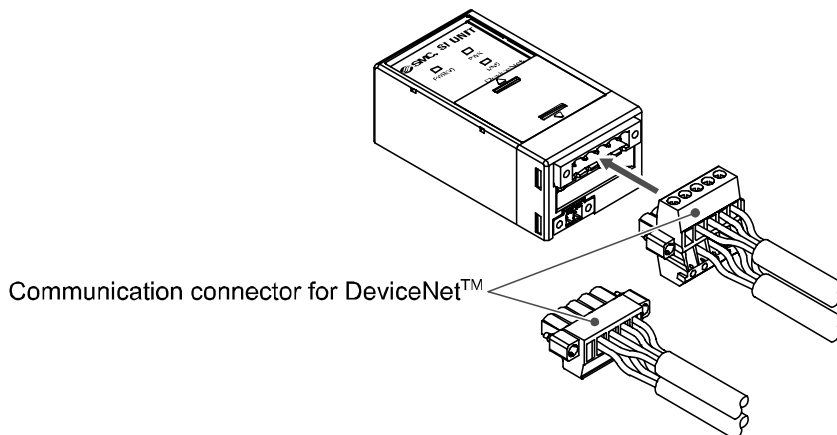

Figure 3

## 2. Wiring of the power supply

Connect the power supply to the power supply connector (1 pc.).

The power supply connector is suitable for use with wire sizes from AWG28 to 16 (0.14 mm<sup>2</sup> to 1.5 mm<sup>2</sup>). The EX180 power supply structure consists of two systems. These systems can operate alone or with another power supply.

Wire to the assigned pins. (Figure 4, Figure 5)

The tightening torque is 0.22 to 0.25 Nm.

### •Note

Ground the FG terminal with a ground resistance of 100 Ω or less.

A. Dual power supplies

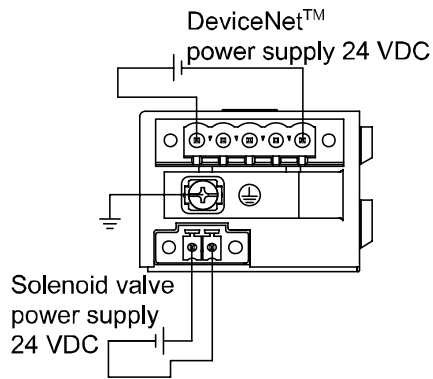

Figure 4

B. Single power supply

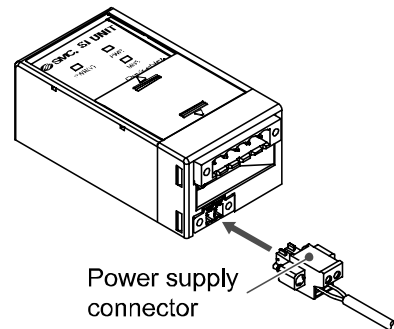
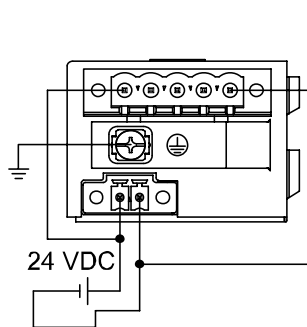
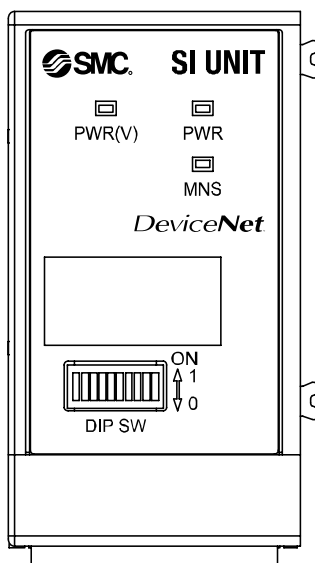

Figure 5

## LED Indication and Settings

### oLED Indication



LED	Description	LED status
PWR(V)	Solenoid valve power supply is supplied at specified voltage	ON
	Solenoid valve power supply is not supplied at specified voltage	OFF
PWR	Communication power supply for DeviceNet™ is supplied	ON
	Communication power supply for DeviceNet™ is not supplied	OFF
MNS	Communication power supply for DeviceNet™ is OFF, off line or a MAC ID duplication is present	OFF
	I/O connection is waiting (On line status)	Green flashing
	I/O connection is established (On line status)	Green ON
	I/O connection / time out (Minor communication error)	Red flashing
	MAC ID duplication error or BUS OFF error (Serious communication error)	Red ON

○Switch setting

Turn off the power supply while setting the DIP switches.

Open the cover and set the DIP switches with a small flat blade screwdriver.

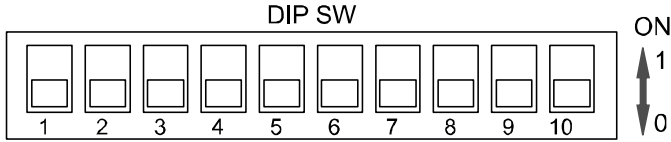

Communication speed setting

Communication speed	No.7	No.8
125 kbps	0	0
250 kbps	1	0
500 kbps	0	1
Invalid	1	1

Factory default setting is 125 kbps.

HOLD/CLR setting

HOLD/CLR	No.9	Description
HOLD	1	Hold the last state before communication error.
CLR	0	Clear all outputs.

Factory default setting is CLEAR.

It is possible to set the output behaviour in the event of a communication error individually via the DeviceNet™ network.

If the output behaviour is set via the DeviceNet™ Network then the setting of DIP switch 9 is invalid.

SW/HW mode setting

SW/HW	No.10	Description
SW	1	Setting for MAC ID and baud rate are done via a network. *: No.1 to No.8 of DIP SW will be invalid.
HW	0	Setting for MAC ID and baud rate are done with No.1 to No.8 of DIP SW.

Factory default setting is HW mode.

The MAC ID and communication speed will be retained if the unit is powered off and software mode is selected (DIP switch 10).

If HW mode is selected then the settings stored using SW mode will be replaced by the HW settings.

●MAC ID setting

MAC ID setting	No.1	No.2	No.3	No.4	No.5	No.6
#0	0	0	0	0	0	0
#1	0	0	0	0	0	1
#2	0	0	0	0	1	0
:	:	:	:	:	:	:
#62	1	1	1	1	1	0
#63	1	1	1	1	1	1

The default setting is all switches ON, so the MAC ID is set to 63.

The MAC ID should be set in a range of 0 to 63.

○Output number assignment

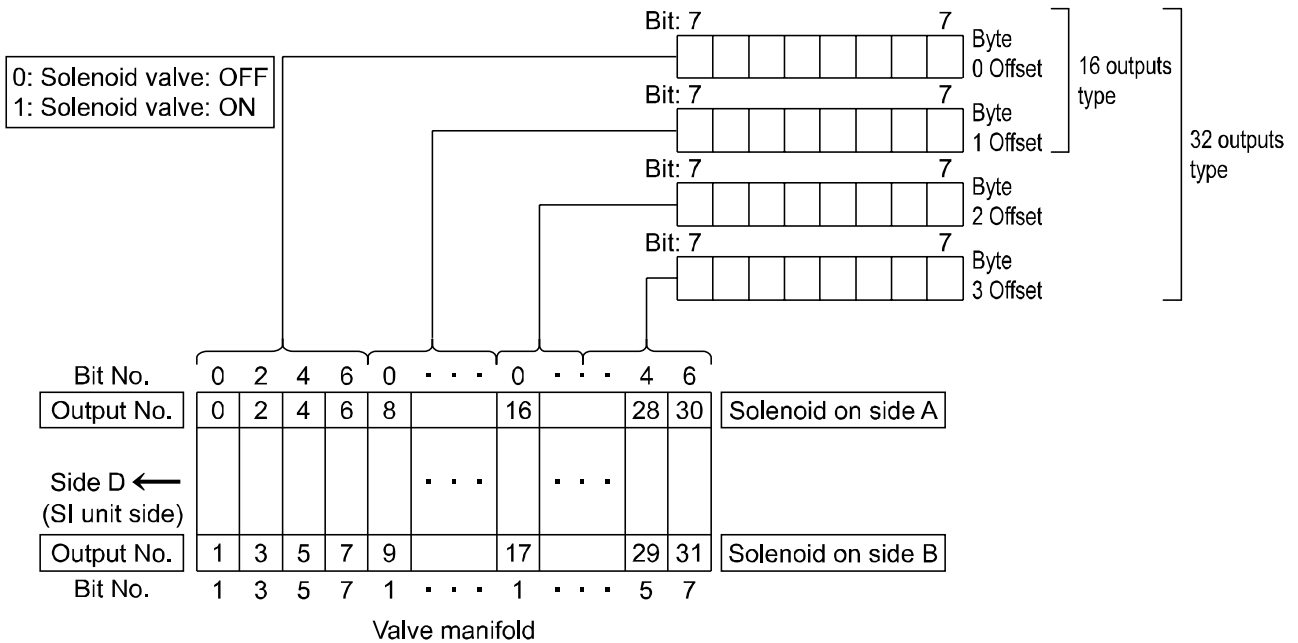

- \*: The output number refers to the solenoid position on the manifold and starts at zero.
- \*: Standard wiring on the manifold is for double-solenoid valves and output number starts A side and B side in that order as shown in the Figure a.  
If you mount a single-solenoid valve on the standard wiring manifold, output number for B side valve is skipped.
- \*: Custom wiring for mixed mounting single-solenoid valves and double-solenoid-valves can be specified with a Wiring Specification Sheet. Example wiring is shown in the Figure b.
- \*: Bit status "0" and "1" on a data corresponds solenoid valve status ON and OFF (0: OFF, 1: ON), and output number starts at zero from LSB (least significant bit).

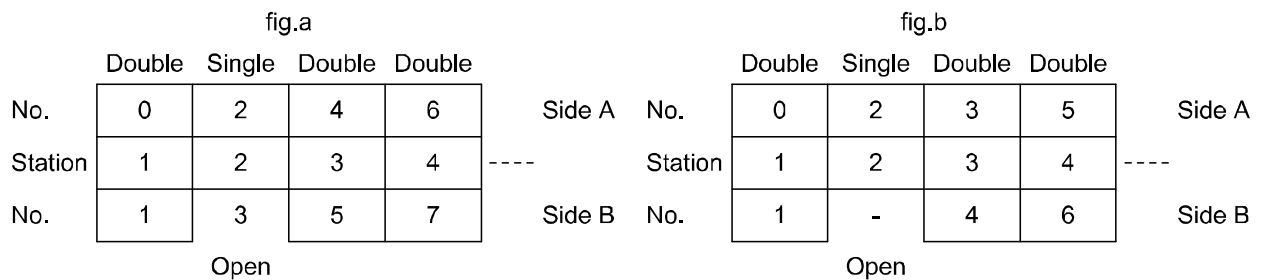

# DeviceNet™ Objects

The EX180 SI unit supports the following DeviceNet™ object classes and the device type is Pneumatic Valves.

\*: xxh indicates a hexadecimal number.

Class code	Object class
01h	Identity
02h	Message Router
03h	DeviceNet™
04h	Assembly
05h	DeviceNet™ Connection
09h	Discrete Output Point
0Fh	Parameter
2Bh	Acknowledge Handler
64h	SMC SI (SMC Specific)

## 1. Identity Object (Class ID: 01h)

### 1-1. Class attribute

ID	Access rule	Description	Value
-	-	-	-

### 1-2. Class common service

Service code	Service name
-	-

### 1-3. Instance attribute

ID	Access rule	Description	Value
1	Get	Vender ID	07h
2	Get	Device Type	1Bh
3	Get	Product Code	87h (135): EX180-SDN3, SDN3A 88h (136): EX180-SDN4, SDN4A 89h (137): EX180-SDN5, SDN5A 8Ah (138): EX180-SDN6, SDN6A
4	Get	Revision	Per unit
5	Get	Status	-
6	Get	Serial Number	Per unit
7	Get	Product Name	Valve Manifold SIU

### 1-4. Instance common service

Service code	Service name
05h	Reset
0Eh	Get_Attribute_Single

### 1-5. Specific service

None

2. Message Router Object (ClassID: 02h)

2-1. Class attribute

ID	Access rule	Description	Value
-	-	-	-

2-2. Class common service

Service code	Service name
-	-

2-3. Instance attribute

ID	Access rule	Description	Value
-	-	-	-

2-4. Instance common service

Service code	Service name
-	-

2-5. Specific service

None

3. DeviceNet™ Object (Class ID: 03h)

3-1. Class attribute

ID	Access rule	Description	Value
1	Get	revision	2

3-2. Class common service

Service code	Service name
0Eh	Get_Attribute_Single

3-3. Instance attribute

ID	Access rule	Description	Value
1	Get/Set *1	MAC ID	0-63
2	Get/Set *1	Baud Rate	0-2
3	Get/Set	BOI	0-1
4	Get/Set	Bus-off Counter	0-255
5	Get	Allocation Information	-
6	Get	MAC ID Switch Changed	0-1
7	Get	Baud Rate Switch Changed	0-1
8	Get	MAC ID Switch Value	0-63
9	Get	Baud Rate Switch Value	0-2
10	Set	Quick Connect	0-1

\*1: "Set" is available in SW mode.

### 3-4. Instance common service

Service code	Service name
0Eh	Get_Attribute_Single
10h	Set_Attribute_Single

### 3-5. Specific service

Service code	Service name
4Bh	Allocate_Master/Slave_Connection_set
4Ch	Release_Group_2_Identifier_Set

## 4. Assembly Object (Class ID: 04h)

### 4-1. Class attribute

ID	Access rule	Description	Value
-	-	-	-

### 4-2. Class common service

Service code	Service name
-	-

### 4-3. Instance attribute

ID	Access rule	Description
3	Get/Set	Data

### 4-4. Solenoid Output Assembly Instance

Instance	Type	Description	Byte
35	Output	16 Solenoid Output Points	02h
37	Output	32 Solenoid Output Points	04h

The data format is shown below.

ID	Byte offset	Data							
		bit7				bit0			
35	+0	OUT7	OUT6	OUT5	OUT4	OUT3	OUT2	OUT1	OUT0
	+1	OUT15	OUT14	OUT13	OUT12	OUT11	OUT10	OUT9	OUT8
37	+0	OUT7	OUT6	OUT5	OUT4	OUT3	OUT2	OUT1	OUT0
	+1	OUT15	OUT14	OUT13	OUT12	OUT11	OUT10	OUT9	OUT8
	+2	OUT23	OUT22	OUT21	OUT20	OUT19	OUT18	OUT17	OUT16
	+3	OUT31	OUT30	OUT29	OUT28	OUT27	OUT26	OUT25	OUT24

#### 4-5. Instance common service

Service code	Service name
0Eh	Get_Attribute_Single
10h	Set_Attribute_Single

#### 4-6. Specific service

None

### 5. DeviceNet™ Connection Object (Class ID: 05h)

#### 5-1. Class attribute

ID	Access rule	Description	Value
-	-	-	-

#### 5-2. Class common service

Service code	Service name
-	-

#### 5-3. Instance attribute 1 (Explicit message)

ID	Access rule	Description	Value
1	Get	State	-
2	Get	Instance_type	00h
3	Get	TransportClass_trigger	83h
4	Get	DeviceNet™_produced_connection_id	-
5	Get	DeviceNet™_consumed_connection_id	-
6	Get	DeviceNet™_initial_comm_characteristics	21h
7	Get	Produced_connection_size	FFFFh
8	Get	Consumed_connection_size	FFFFh
9	Get/Set	Expected_packet_rate	-
12	Get/Set	Watchdog_timeout_action	-
13	Get	Produced_connection_path_length	0
14	Get	Produced_connection_path	None
15	Get	Consumed_connection_path_length	0
16	Get	Consumed_connection_path	None
17	Get	Production_inhibit_time	0

5-4. Instance attribute2 (I/O: Poll message)

ID	Access rule	Description	Value
1	Get	State	-
2	Get	Instance_type	01h
3	Get	TransportClass_trigger	83h: Poll 80h: COS/Cylic-Ack not present 83h: COS/Cylic-Ack present
4	Get	DeviceNet™_produced_connection_id	-
5	Get	DeviceNet™_consumed_connection_id	-
6	Get	DeviceNet™_initial_comm_characteristics	01h
7	Get	Produced_connection_size	00h
8	Get	Consumed_connection_size	04h: EX180-SDN3, EX180-SDN3A 04h: EX180-SDN5, EX180-SDN5A 02h: EX180-SDN4, EX180-SDN4A 02h: EX180-SDN6, EX180-SDN6A
9	Get/Set	Expected_packet_rate	-
12	Get/Set	Watchdog_timeout_action	-
13	Get	Produced_connection_path_length	0
14	Get	Produced_connection_path	None
15	Get	Consumed_connection_path_length	6
16	Get	Consumed_connection_path	20h 04h 24h xxh 30h 03h 25: EX180-SDN3, EX180-SDN3A 25: EX180-SDN5, EX180-SDN5A 23: EX180-SDN4, EX180-SDN4A 23: EX180-SDN6, EX180-SDN6A
17	Get	Production_inhibit_time	0

5-5. Instance attribute 4 (I/O: COS/Cyclic message)

ID	Access rule	Description	Value
1	Get	State	-
2	Get	Instance_type	01 (I/O)
3	Get	TransportClass_trigger	13h: COS-Ack present 10h: COS-Ack not present 03h: Cyclic-Ack present 00h: Cyclic-Ack not present
4	Get	Produced_connection_id	-
5	Get	Consumed_connection_id	-
6	Get	Initial_comm_characteristics	01h: Ack present 0Fh: Ack not present
7	Get	Produced_connection_size	0 Byte
8	Get	Consumed_connection_size	0 Byte
9	Get/Set	Expected_packet_rate	-
12	Get/Set	Watchdog_timeout_action	-
13	Get	Produced_connection_path_length	0
14	Get	Produced_connection_path	None
15	Get	Consumed_connection_path_length	4: Ack present 0: Ack not present
16	Get	Consumed_connection_path	20h 2Bh 24h 01h (Ack present) None (Ack not present)
17	Set	Production_inhibit_time	-

5-6. Instance common service

Service code	Service name
0Eh	Get_Attribute_Single
10h	Set_Attribute_Single
05h	Reset

6. Discrete Output Point Object (Class ID: 09h)

6-1. Class attribute

ID	Access rule	Description	Value
-	-	-	-

6-2. Class common service

Service code	Service name
-	-

### 6-3. Instance attribute

ID	Access rule	Description	Value
3	Get/Set	Value	0: OFF, 1: ON
4	Get	Status	0: OK 1: Abnormal valve power supply voltage or valve power supply fuse has blown
5	Get/Set	Fault Action	0: Fault value 1: Holding output
6	Get/Set	Fault Value	0: Clear 1: Set
7	Get/Set	Idle Action	0: Idle value 1: Holding output
8	Get/Set	Idle Value	0: Clear 1: Set

\*: Hold the data in EEPROM.

### 6-4. Instance common service

Service code	Service name
0Eh	Get_Attribute_Single
10h	Set_Attribute_Single

### 6-5. Specific service

None

## 7. Parameter Object (Class ID: 0Fh)

### 7-1. Class attribute

ID	Access rule	Description	Value
2	Get	Max Instance	4
8	Get	Parameter Class Descriptor	1
9	Get	Configuration Assembly Instance	0

### 7-2. Class common service

Service code	Service name
0Eh	Get_Attribute_Single

### 7-3. Instance attribute 1: SOLV Status

ID	Access rule	Description	Value
1	Get	Parameter Value	0: Valve power supply voltage is normal. 1: Valve power supply voltage is abnormal.
2	Get	Link Path Size	6
3	Get	Link Path	20h 64h 24h 01h 30h 64h
4	Get	Descriptor	3Ch
5	Get	Data Type	C1h
6	Get	Data Size	1

7-4. Instance attribute 2: SOLV Fuse Status

ID	Access rule	Description	Value
1	Get	Parameter Value	0: Valve power supply fuse is normal 1: Valve power supply fuse has blown
2	Get	Link Path Size	6
3	Get	Link Path	20h 64h 24h 01h 30h 65h
4	Get	Descriptor	30h
5	Get	Data Type	C1h
6	Get	Data Size	1

7-5. Instance attribute 3: Hold Clear Timeout

ID	Access rule	Description	Value
1	Get/Set	Parameter Value	0: DIP-SW valid 1: EEPROM valid
2	Get	Link Path Size	6
3	Get	Link Path	20h 64h 24h 01h 30h 68h
4	Get	Descriptor	20h
5	Get	Data Type	C1h
6	Get	Data Size	1

7-6. Instance attribute 4: Hold/Clear Select (Connection Delete)

ID	Access rule	Description	Value
1	Get	Parameter Value	0: Fault action is valid 1: Clear is valod
2	Set	Link Path Size	6
3	Set	Link Path	20h 64h 24h 01h 30h 69h
		Segment type/port	-
		Segment Address	-
4	Get	Descriptor	20h
5	Get	Data Type	C1h
6	Get	Data Size	1

8. Acknowledge Handler Object (Class ID: 2Bh)

8-1. Class attribute

ID	Access rule	Description	Value
-	-	-	-

8-2. Class common service

Service code	Service name
-	-

### 8-3. Instance attribute

ID	Access rule	Description	Value
1	Set	Acknowledge Timer	-
2	Get/Set	Retry Limit	-
3	Get	COS Producing Connection	4

### 8-4. Instance common service

Service code	Service name
0Eh	Get_Attribute_Single
10h	Set_Attribute_Single

## 9. SMC SI Object (Class ID: 64h)

### 9-1. Class attribute

ID	Access rule	Description	Value
-	-	-	-

### 9-2. Class common service

Service code	Service name
-	-

### 9-3. Instance attribute

ID	Access rule	Description	Value
100	Get	SOLV Status	0: OK 1: Abnormal valve power supply voltage
101	Get	SOLV Fuse Status	0: OK 1: Valve power supply fuse has blown
104	Get/Set	Hold/Clear (Time Out)	0: DIP switch is valid (Initial value) 1: EEPROM valid
105	Get/Set	Hold/Clear (Connection Delete) Setting	0: Fault action is valid (Initial value) 1: Clear

### 9-4. Instance common service

Service code	Service name
0Eh	Get_Attribute_Single
10h	Set_Attribute_Single

### 9-5. Specific service

None

# Troubleshooting and Maintenance

## ○ Troubleshooting Chart

**Applicable SI unit: EX180-SDN3□/4□/5□/6□**

When any malfunction is observed, perform the following troubleshooting.

When the troubleshooting does not apply to your problem and the operation returns to normal after replacing the SI unit, it is presumed that SI unit has malfunctioned. It may be possible that the malfunctioning of the SI unit is caused by the operating environment (network structure). Please consult SMC if further troubleshooting is necessary.

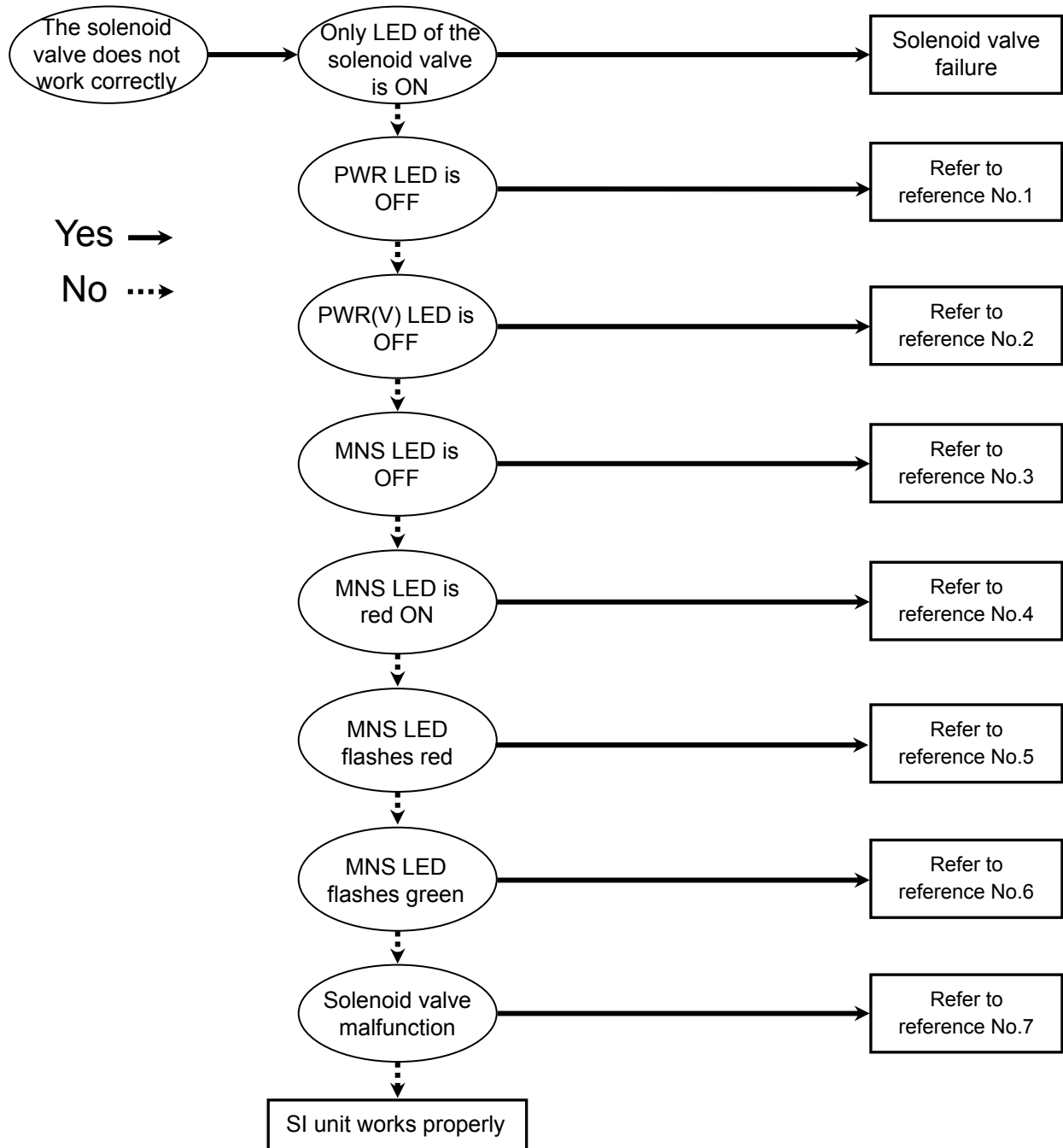

○Cross-Reference for Troubleshooting

Reference No.	Problem	Possible cause	Investigation method	Countermeasure
1	PWR LED is OFF	Wiring failure of communication power supply for DeviceNet™	Check the DeviceNet™ cable is not broken and confirm that the connection between the cable and the connector is not loose. Confirm that repeated bending stress or pulling forces which can cause a broken wire is not applied to the cable.	Connect DeviceNet™ cable correctly.
			Confirm the DeviceNet™ cable wiring is correct.	Wire correctly.
		Failure of communication power supply for DeviceNet™	Confirm the DeviceNet™ supply voltage for communication is within specification.	Supply 11 to 25 VDC to the communication power supply for DeviceNet™.
2	PWR(V) LED is OFF	Wiring failure of the power supply for the solenoid valve	Check the cable for the solenoid valve is not broken, and confirm that the connection between the power supply cable and the connector is not loose. Confirm that repeated bending stress or pulling force which can cause a broken wire is not applied to the cable.	Connect the power supply cable correctly.
			Confirm the wiring of the power supply for the solenoid valve is correct.	Wire correctly.
		Failure of the power supply for the solenoid valve	Confirm the supply voltage for the power supply for the solenoid valve.	Supply 24 VDC +10/-5% for the power supply for the solenoid valve.

Reference No.	Problem	Possible cause	Investigation method	Countermeasure
3	MNS LED is OFF	Failure of the power supply for the master station	Confirm that power is supplied to the master station	Supply power to the master station correctly.
		Communication line wiring failure	Check the DeviceNet™ cable is not broken and confirm that the connection between the cable and the connector is not loose. Confirm that repeated bending stress or pulling forces which can cause a broken wire is not applied to the cable.	Connect DeviceNet™ cable correctly.
			Confirm the DeviceNet™ cable wiring is correct.	Wire correctly.
		Communication failure	Check that there is no equipment or high voltage line that can generate noise around the communication and power supply lines.	Keep the DeviceNet™ cable and the power supply cable away from the noise source.
		MAC ID duplication	Check that there is no MAC ID duplication between the master and slaves.	Set MAC ID correctly
			Confirm that the communication speed setting of the SI unit and the communication speed setting of the master and slave station are the same.	Set the communication speed correctly.
4	RUN LED is red ON	MAC ID duplication	Check that there is no MAC ID duplication between the master and slaves.	Set MAC ID correctly
		BUS OFF error	Check the wiring length of the communication line and the presence of the termination resistors at both ends of the DeviceNet™ network.	Wire and set correctly.
			Check that there is no equipment or high voltage line that can generate noise around the communication and power supply lines.	Keep the communication and power supply cables away from the noise source.
			Check the DeviceNet™ cable is not broken and confirm that the connection between the cable and the connector is not loose. Confirm that repeated bending stress or pulling forces which can cause a broken wire is not applied to the cable.	Connect DeviceNet™ cable correctly.
			Confirm that the communication speed setting of the SI unit and the communication speed setting of the master and slave station are the same.	Set the communication speed correctly.
		Communication device failure	Irrecoverable error occurs to SI unit.	Replace the SI unit.

Reference No.	Problem	Possible cause	Investigation method	Countermeasure
5	MNS LED flashes red	I/O connection time out	Check the wiring length of the communication line and the presence of the termination resistors at both ends of the DeviceNet™ network.	Wire and set correctly.
			Check that there is no equipment or high voltage line that can generate noise around the communication and power supply lines.	Keep the communication and power supply cables away from the noise source.
			Check the DeviceNet™ cable is not broken and confirm that the connection between the cable and the connector is not loose. Confirm that repeated bending stress or pulling forces which can cause a broken wire is not applied to the cable.	Connect DeviceNet™ cable correctly.
			Confirm that the communication speed setting of the SI unit and the communication speed setting of the master and slave station are the same.	Set the communication speed correctly.
			Confirm that power is supplied to the master station	Supply power to the master station correctly.
6	MNS LED flashes green	I/O connection is waiting (Off line status)	Slave connection stand-by	Check that the MAC ID and communication speed settings of the slave are correct.
			If the network is using a scan list, check that the slave is registered correctly into the scan list.	Register the scan list correctly.

Reference No.	Problem	Possible cause	Investigation method	Countermeasure
7	Solenoid valve malfunction	Solenoid valve failure	Check the operation by replacing the solenoid valve. Or refer to Troubleshooting for the solenoid valve.	Check the Troubleshooting for the solenoid valve. Or contact to the department in charge of the solenoid valve
		Connection between SI unit and valve manifold is defective	Check that there is no contact failure such as bending of the connector pins between the SI unit and valve manifold.	Connect the SI unit and valve manifold properly.
		The solenoid valve does not work	Check the total number solenoid valves connected to the manifold does not exceed the max. number of outputs of the SI unit.	The number of solenoid valve outputs that can be connected to the manifold has to be smaller or equal to the max. number of outputs. EX180-SDN3□, EX180-SDN5□ : Max. 32 outputs EX180-SDN4□, EX180-SDN6□ : Max. 16 outputs
		Solenoid valve output is being held	Check the HOLD/CLR setting of the SI unit	Set HOLD/CLR setting correctly.

\*: When MNS LED red is ON, the SI unit is not automatically recovered even if the cause is eliminated.  
Supply the power supply for DeviceNet™ of SI unit again.

## ■ Maintenance

### ● Mounting/Wiring

Item	Criterion	Remedy
Check the SI unit connector for the communication and the power supply are connected properly.	Not loose.	Perform extra tightening. (Refer to "Wiring" of this operation manual)
Confirm that the terminal resistor is properly connected to both ends of the DeviceNet™ network.	Not loose.	Perform extra tightening.
Confirm that the connection cable is not broken.	No problem on the appearance.	If any problem is confirmed from the appearance, replace the cable.

### ● Hardware

Item	Criterion	Remedy
Cable for moving parts (If the cable is used)	No problem is found on the appearance or the conductor resistance value. (Confirm that the resistance value does not exceed the specification)	If any visible problem is found or the conductor resistance value is out of specification, replace the cable.
SI unit.	No abnormal operation or LED display.	Replace the SI unit if the operation or LED display is abnormal.

### ● Power supply

Item	Criterion	Remedy
Measure the voltage at both ends of the DeviceNet™ power supply and check if the voltage is within the specified range.	11 to 25 VDC	Investigate the cause of voltage fluctuation and fix the problem.
Measure the voltage at both ends of the solenoid valve power supply and check if the voltage is within the specified range.	24 VDC +10/-5%	Investigate the cause of voltage fluctuation and fix the problem.

# Specifications

## ■ Table of Specifications

### ● General specifications

Item		Specifications
Rated voltage		24 VDC
Power supply voltage range		Communication power supply for DeviceNet™: 11 to 25 VDC Power supply for the solenoid valves: 24 VDC +10/-5%
Current consumption		Communication power supply for DeviceNet™: 0.1 A or less Power supply for the solenoid valves
Output specification	Output type	EX180-SDN3□/4□: NPN (positive common) EX180-SDN5□/6□: PNP (negative common)
	Number of outputs	EX180-SDN3□/5□: 32 points EX180-SDN4□/6□: 16 points
	Connection load	Solenoid valve with light and surge voltage suppressor of 24 VDC and 1 W or less (manufactured by SMC)
	Output setting at the time of communication error	Hold/Clear (Switch setting)
Environment	Enclosure	IP20
	Withstand voltage	500 VAC 1 min. (Between FG and external terminal)
	Insulation resistance	10 MΩ or more (500 VDC, Between FG and external terminal)
	Ambient temperature	Working temperature: -10 to 50 °C Storage: -20 to 60 °C
	Ambient humidity	35 to 85%RH (Non condensing)
	Operating atmosphere	No corrosive gas
	Pollution degree	Pollution degree 3 *
Standard		UL/CSA (E209424), CE marking
Weight		110 g or less (Including accessories)

\*: This product is IP20 rated.

When operating this product in a pollution degree 3 environment, mount it onto an IP54 rate or higher controller board etc.

•Network communication specifications

Item		Specifications		
Applicable system		DeviceNet™ Volume1 (Edtion2.1) Volume3 (Edtion1.1)		
Slave type		Group2 Only Server		
Device type		27 (Pneumatic valve)		
Product code		87h (135): EX180-SDN3□ 88h (136): EX180-SDN4□ 89h (137): EX180-SDN5□ 8Ah (138): EX180-SDN6□		
Vender ID		7 (SMC Corp.)		
Applicable message		Duplicate MAC ID Check Message Unconnected Explicit Message Explicit Message		
MAC ID set range		0 to 63		
Data rate		125 kbps	250 kbps	500 kbps
Max. length of the network	Thick cable	500 m or less	250 m or less	100 m or less
	Thin cable	100 m or less		
Total main and branch line length		156 m or less	78 m or less	39 m or less
		*: Max. length of branch line is 6 m.		
Occupied bytes		EX180-SDN3□/5□: Output 4 bytes, input 0 bytes EX180-SDN4□/6□: Output 2 bytes, input 0 bytes		

# Dimensions

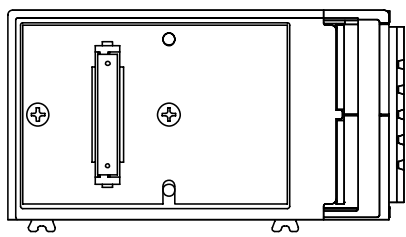
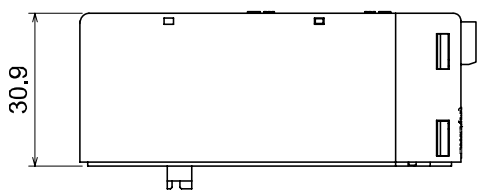
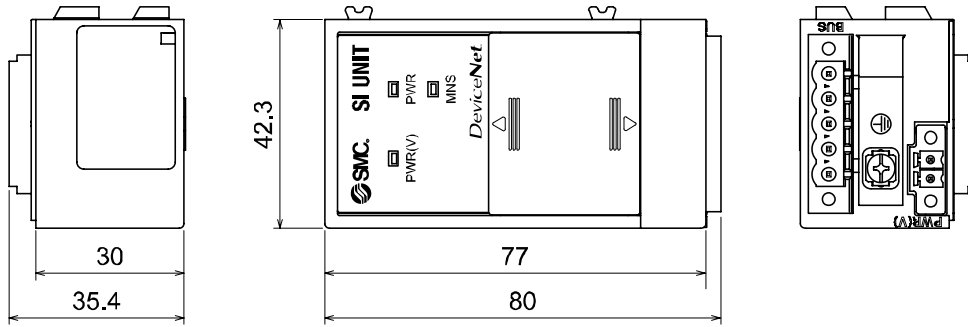

Unit: mm

EX180-SDN3/4/5/6

EX180-SDN3A/4A/5A/6A

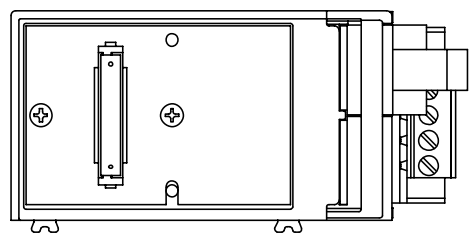
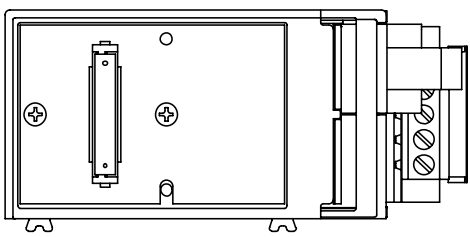
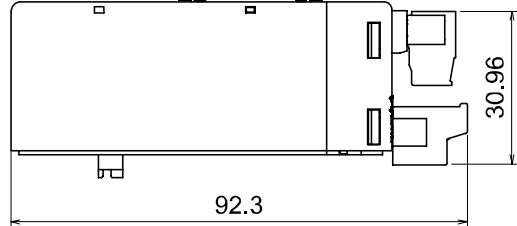
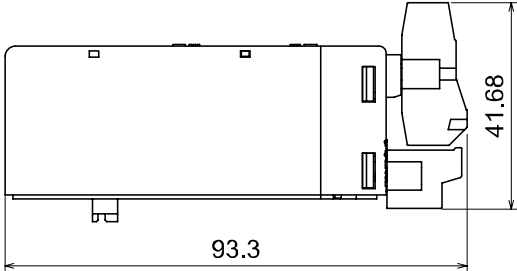

Revision history
A: Revision (page 2, page 31)

# SMC Corporation

4-14-1, Sotokanda, Chiyoda-ku, Tokyo 101-0021 JAPAN

Tel: +81 3 5207 8249 Fax: +81 3 5298 5362

URL <http://www.smcworld.com>

---

Note: Specifications are subject to change without prior notice and any obligation on the part of the manufacturer.

DeviceNet™ is a trademark of ODVA.

© 2010-2011 SMC Corporation All Rights Reserved

