



Operation Manual

PRODUCT NAME

Fieldbus system
(SI unit – PROFIBUS DP compatible)

MODEL / Series / Product Number

EX250-SPR1

SMC Corporation



Table of Contents

Safety Instructions	2
Model Indication and How to Order	7
Summary of Product Parts	7
Mounting and Installation	8
Installation	8
Wiring	9
Setting	14
Troubleshooting	21
Specifications	26
Specifications	26
Dimensions	27

Safety Instructions

These safety instructions are intended to prevent hazardous situations and/or equipment damage. These instructions indicate the level of potential hazard with the labels of "Caution", "Warning" or "Danger". They are all important notes for safety and must be followed in addition to International standards (ISO/IEC) *1) and other safety regulations.

- *1) ISO 4414: Pneumatic fluid power -- General rules relating to systems.
- ISO 4413: Hydraulic fluid power -- General rules relating to systems.
- IEC 60204-1: Safety of machinery -- Electrical equipment of machines. (Part 1: General requirements)
- ISO 10218-1992: Manipulating industrial robots -Safety.
- etc.

- | | | |
|---|------------------|--|
|  | Caution : | CAUTION indicates a hazard with a low level of risk which, if not avoided, could result in minor or moderate injury. |
|  | Warning : | WARNING indicates a hazard with a medium level of risk which, if not avoided, could result in death or serious injury. |
|  | Danger : | DANGER indicates a hazard with a high level of risk which, if not avoided, will result in death or serious injury. |

Warning

1. The compatibility of the product is the responsibility of the person who designs the equipment or decides its specifications.

Since the product specified here is used under various operating conditions, its compatibility with specific equipment must be decided by the person who designs the equipment or decides its specifications based on necessary analysis and test results. The expected performance and safety assurance of the equipment will be the responsibility of the person who has determined its compatibility with the product. This person should also continuously review all specifications of the product referring to its latest catalogue information, with a view to giving due consideration to any possibility of equipment failure when configuring the equipment.

2. Only personnel with appropriate training should operate machinery and equipment.

The product specified here may become unsafe if handled incorrectly. The assembly, operation and maintenance of machines or equipment including our products must be performed by an operator who is appropriately trained and experienced.

3. Do not service or attempt to remove product and machinery/equipment until safety is confirmed.

1. The inspection and maintenance of machinery/equipment should only be performed after measures to prevent falling or runaway of the driven objects have been confirmed.
2. When the product is to be removed, confirm that the safety measures as mentioned above are implemented and the power from any appropriate source is cut, and read and understand the specific product precautions of all relevant products carefully.
3. Before machinery/equipment is restarted, take measures to prevent unexpected operation and malfunction.

4. Contact SMC beforehand and take special consideration of safety measures if the product is to be used in any of the following conditions.

1. Conditions and environments outside of the given specifications, or use outdoors or in a place exposed to direct sunlight.
2. Installation on equipment in conjunction with atomic energy, railways, air navigation, space, shipping, vehicles, military, medical treatment, combustion and recreation, or equipment in contact with food and beverages, emergency stop circuits, clutch and brake circuits in press applications, safety equipment or other applications unsuitable for the standard specifications described in the product catalogue.
3. An application which could have negative effects on people, property, or animals requiring special safety analysis.
4. Use in an interlock circuit, which requires the provision of double interlock for possible failure by using a mechanical protective function, and periodical checks to confirm proper operation.

Caution

The product is provided for use in manufacturing industries.

The product herein described is basically provided for peaceful use in manufacturing industries. If considering using the product in other industries, consult SMC beforehand and exchange specifications or a contract if necessary.
If anything is unclear, contact your nearest sales branch.

Limited warranty and Disclaimer/Compliance Requirements

The product used is subject to the following "Limited warranty and Disclaimer" and "Compliance Requirements".

Read and accept them before using the product.

Limited warranty and Disclaimer

1. The warranty period of the product is 1 year in service or 1.5 years after the product is delivered. *2)
Also, the product may have specified durability, running distance or replacement parts. Please consult your nearest sales branch.
2. For any failure or damage reported within the warranty period which is clearly our responsibility, a replacement product or necessary parts will be provided.
This limited warranty applies only to our product independently, and not to any other damage incurred due to the failure of the product.
3. Prior to using SMC products, please read and understand the warranty terms and disclaimers noted in the specified catalogue for the particular products.

*2) Vacuum pads are excluded from this 1 year warranty.

A vacuum pad is a consumable part, so it is warranted for a year after it is delivered.

Also, even within the warranty period, the wear of a product due to the use of the vacuum pad or failure due to the deterioration of rubber material are not covered by the limited warranty.

Compliance Requirements

1. The use of SMC products with production equipment for the manufacture of weapons of mass destruction (WMD) or any other weapon is strictly prohibited.
2. The exports of SMC products or technology from one country to another are governed by the relevant security laws and regulation of the countries involved in the transaction. Prior to the shipment of a SMC product to another country, assure that all local rules governing that export are known and followed.

Operator

- ◆ This operation manual is intended for those who have knowledge of machinery using pneumatic equipment, and have sufficient knowledge of assembly, operation and maintenance of such equipment. Only those persons are allowed to perform assembly, operation and maintenance.
- ◆ Read and understand this operation manual carefully before assembling, operating or providing maintenance to the product.

■ Safety Instructions

Warning

- Do not disassemble, modify (including changing the printed circuit board) or repair.
An injury or failure can result.
- Do not operate the product outside of the specifications.
Do not use for flammable or harmful fluids.
Fire, malfunction, or damage to the product can result.
Verify the specifications before use.
- Do not operate in an atmosphere containing flammable or explosive gases.
Fire or an explosion can result.
This product is not designed to be explosion proof.
- If using the product in an interlocking circuit:
 - Provide a double interlocking system, for example a mechanical system.
 - Check the product regularly for proper operation.Otherwise malfunction can result, causing an accident.
- The following instructions must be followed during maintenance:
 - Turn off the power supply.
 - Stop the air supply, exhaust the residual pressure and verify that the air is released before performing maintenance.Otherwise an injury can result.

Caution

- After maintenance is complete, perform appropriate functional inspections.
Stop operation if the equipment does not function properly.
Safety cannot be assured in the case of unexpected malfunction.
- Provide grounding to assure the safety and noise resistance of the SI unit.
Individual grounding should be provided close to the product with a short cable.

■NOTE

- Follow the instructions given below when designing, selecting and handling the product.
- The instructions on design and selection (installation, wiring, environment, adjustment, operation, maintenance, etc.) described below must also be followed.
- *Product specifications
 - When conformity to UL is necessary the SI unit must be used with a UL1310 Class2 power supply.
The SI unit is a UL approved product only if it has a UL mark on the body.
 - Use the specified voltage.
Otherwise failure or malfunction can result.
 - Reserve a space for maintenance.
Allow sufficient space for maintenance when designing the system.
 - Do not remove any nameplates or labels.
This can lead to incorrect maintenance, or misreading of the operation manual, which could cause damage or malfunction to the product.
It may also result in non-conformity to safety standards.
- Product handling
 - *Installation
 - Do not drop, hit or apply excessive shock to the SI unit.
Otherwise damage to the product can result, causing malfunction.
 - Tighten to the specified tightening torque.
If the tightening torque is exceeded the mounting screws may be broken.
IP67 protection cannot be guaranteed if the screws are not tightened to the specified torque.
 - Never mount a product in a location that will be used as a foothold.
The product may be damaged if excessive force is applied by stepping or climbing onto it.
 - *Wiring
 - Avoid repeatedly bending or stretching the cables, or placing heavy load on them.
Repetitive bending stress or tensile stress can cause breakage of the cable.
 - Wire correctly.
Incorrect wiring can break the product.
 - Do not perform wiring while the power is on.
Otherwise damage to the SI unit and/or I/O device can result, causing malfunction.
 - Do not route wires and cables together with power or high voltage cables.
Otherwise the SI unit and/or I/O device can malfunction due to interference of noise and surge voltage from power and high voltage cables to the signal line.
Route the wires (piping) of the SI unit and/or I/O device separately from power or high voltage cables.
 - Confirm proper insulation of wiring.
Poor insulation (interference from another circuit, poor insulation between terminals, etc.) can lead to excess voltage or current being applied to the product, causing damage.
 - Take appropriate measures against noise, such as using a noise filter, when the SI unit is incorporated into equipment.
Otherwise noise can cause malfunction.

*Environment

- Select the proper type of protection according to the environment of operation.
IP67 protection is achieved when the following conditions are met.
 - (1) The units are connected properly with fieldbus cable with M12 connector and power cable with M12/M8 connector.
 - (2) Suitable mounting of each unit and manifold valve.If using in an environment that is exposed to water splashes, please take measures such as using a cover.
- Do not use in a place where the product could be splashed by oil or chemicals.
If the product is to be used in an environment containing oils or chemicals such as coolant or cleaning solvent, even for a short time, it may be adversely affected (damage, malfunction etc.).
- Do not use the product in an environment where corrosive gases or fluids could be splashed.
Otherwise damage to the product and malfunction can result.
- Do not use in an area where surges are generated.
If there is equipment which generates a large amount of surge (solenoid type lifter, high frequency induction furnace, motor, etc.) close to the SI unit, this may cause deterioration or breakage of the internal circuit of the SI unit. Avoid sources of surge generation and crossed lines.
- When a surge-generating load such as a relay or solenoid is driven directly, use an SI unit with a built-in surge absorbing element.
Direct drive of a load generating surge voltage can damage the SI unit.
- The product is CE marked, but not immune to lightning strikes. Take measures against lightning strikes in the system.
- Prevent foreign matter such as remnant of wires from entering the SI unit to avoid failure and malfunction.
Otherwise failure or malfunction can result.
- Mount the product in a place that is not exposed to vibration or impact.
Otherwise failure or malfunction can result.
- Do not use the product in an environment that is exposed to temperature cycle.
Heat cycles other than ordinary changes in temperature can adversely affect the inside of the product.
- Do not expose the product to direct sunlight.
If using in a location directly exposed to sunlight, shade the product from the sunlight.
Otherwise failure or malfunction can result.
- Keep within the specified ambient temperature range.
Otherwise malfunction can result.
- Do not operate close to a heat source, or in a location exposed to radiant heat.
Otherwise malfunction can result.

*Adjustment and Operation

- Set the switches by using a sharp-pointed screwdriver etc.
It may damage set switches.
- Perform settings suitable for the operating conditions.
Incorrect setting can cause operation failure.
For details of each setting, refer to page 14 of this manual.
- Please refer to the PLC manufacturer's manual etc. for details of programming and addresses.
For the PLC protocol and programming refer to the relevant manufacturer's documentation.

*Maintenance

- Turn off the power supply, stop the supplied air, exhaust the residual pressure and verify the release of air before performing maintenance.
There is a risk of unexpected malfunction.
- Perform regular maintenance and inspections.
There is a risk of unexpected malfunction.
- After maintenance is complete, perform appropriate functional inspections.
Stop operation if the equipment does not function properly.
Otherwise safety is not assured due to an unexpected malfunction or incorrect operation.
- Do not use solvents such as benzene, thinner etc. to clean the SI unit.
They could damage the surface of the body and erase the markings on the body.
Use a soft cloth to remove stains.
For heavy stains, use a cloth soaked with diluted neutral detergent and fully squeezed, then wipe up the stains again with a dry cloth.

Model Indication and How to Order

EX250-SPR1

• Communication protocol

PR1	PROFIBUS DP
-----	-------------

Summary of Product Parts

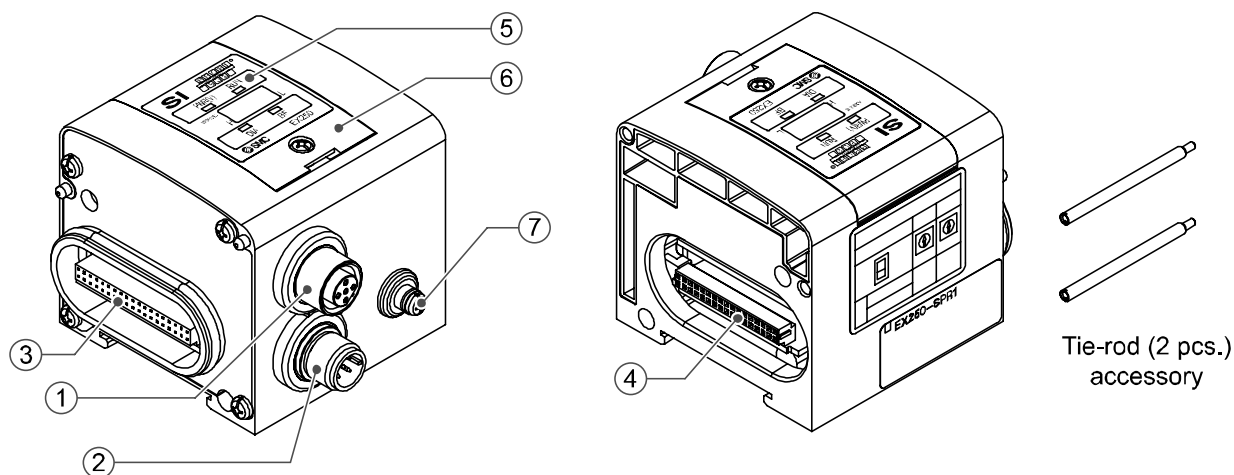

No.	Element	Description
1	Communication connector	Connect with PROFIBUS DP communication line. *1
2	Power supply connector	Supplies power to the solenoid valve, the Output block, SI unit and the Input block. *1
3	Input block connector	Connects the Input block.
4	Output block connector	Connects the solenoid valve, Output block and etc.
5	Display	LED display shows the SI unit status. *2
6	Switch protective cover	Set Station no. and Baud rate by using the switches under the cover. *2
7	Ground terminal (FE)	Used for grounding.

*1: For wiring method, refer to subsection "Wiring" (page 9) in this operation manual.

*2: For display and setting method, refer to subsection "Setting" (page 14) in this Technical Specification.

Mounting and Installation

■ Installation

Not having mounting hole, it can't be set to BUS independently. Be sure to connect manifold to SI unit for setting.

And if Input block is unnecessary, connect End plate directly to SI unit.

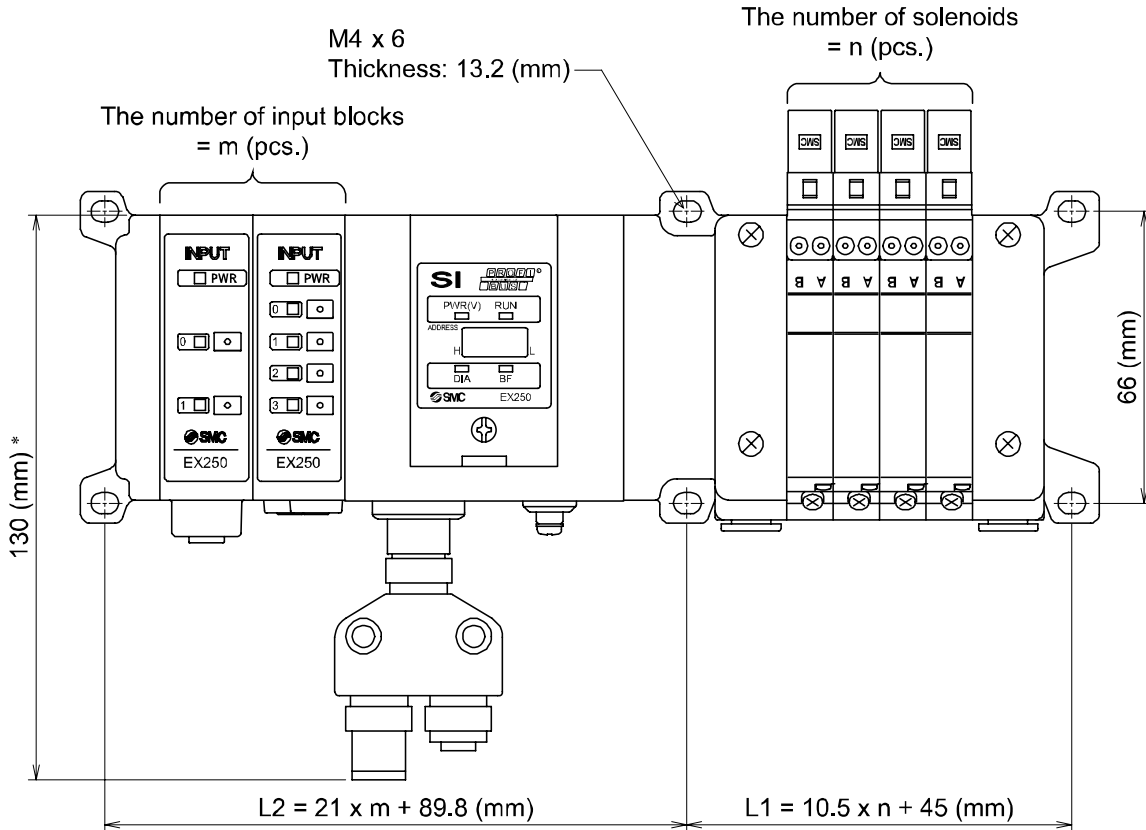

*: The size when connecting Bus Tee with the SI unit directly.

For example, the table below shows the size when manifold of VQC1000 series connected. Please refer to an individual catalog for the size when other manifolds are connected.

$\begin{matrix} N \\ L \end{matrix} \backslash m$	0	1	2	3	4	5	6	7	8	9	10	11	12	13	14	15	16
L1	45	55.5	66	76.5	87	97.5	108	118.5	129	139.5	150	160.5	171	181.5	192	202.5	213
L2	89.8	110.8	131.8	152.8	173.8	194.8	215.8	236.8	257.8	278.8	299.8						

Wiring (for power supply, communication and input) and piping are done on only one side. On the side, make a space for wiring and piping.

•Internal circuit

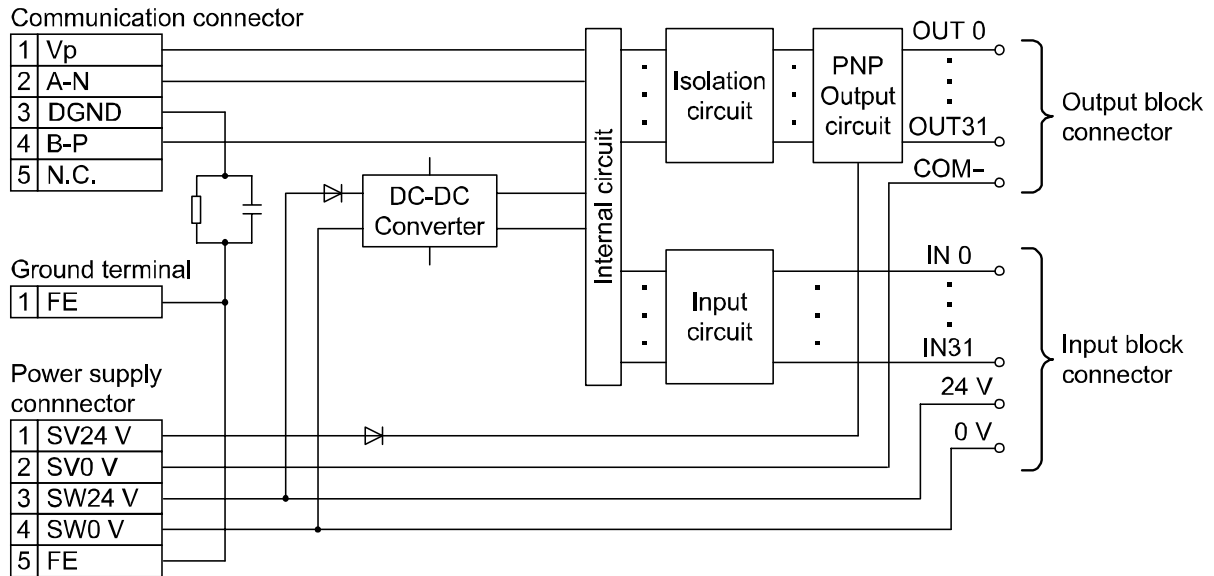

■Wiring

•Communication wiring

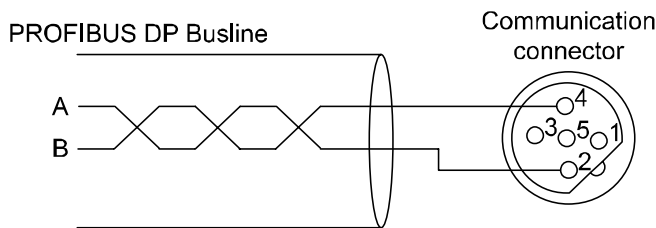

Cable: Shielded twisted pair cable (Type-A cable)

Impedance	135 to 165 ohm(3 to 20 MHz)
Capacity between conductors	30 pF/m or less
Conductor resistance	110 Ω/km or less
Cable diameter	0.64 mm or more
Conductor area	0.34 mm ² or more

•Transmission speed & Maximum wiring length

Baud rate (kbps)	9.6	19.2	45.45	93.75	187.5	500	1500	12000
Wiring length (m)	1200				1000	400	200	100

•Terminator

It is necessary to attach bus terminator resistance to the units located at the ends of transmission line.

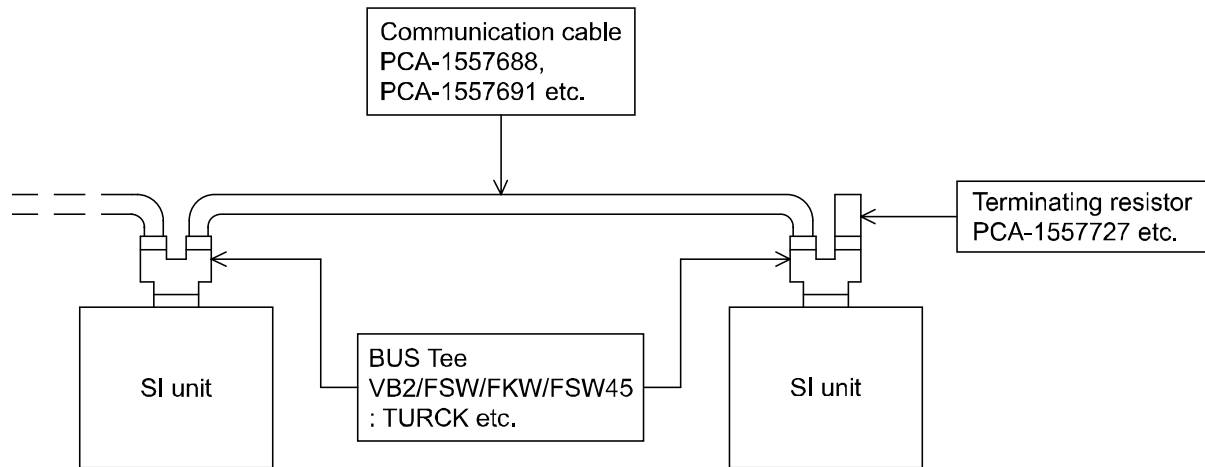

*: Contact each manufacture about Communication cable and Bus Tee.

•Power supply wiring

Power supply line inside the unit has individual power supplies for solenoid valve actuation (SV power supply) and for Control parts and Input block (SI·SW power supply). Supply 24 VDC for each of them. Either single or dual power supply is available.

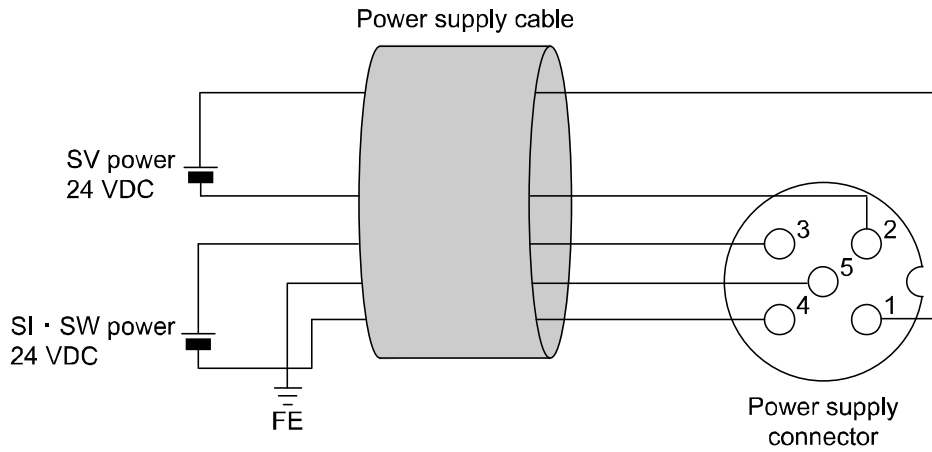

A. Dual power supply

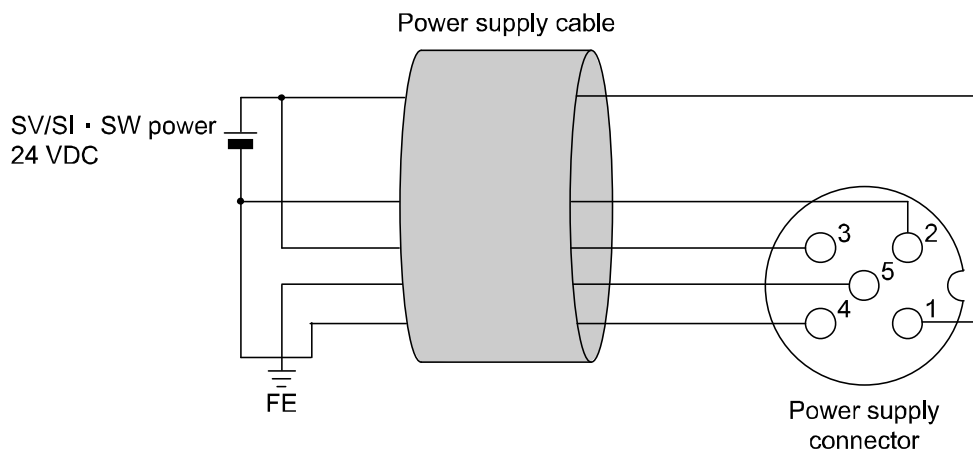

B. Single power supply

*: In case of single power supply, pay attention to the range of each supply voltage.

Power for sensor is supplied to sensor connected with Input block. Select sensor concerning voltage drop up to maximum 1 V inside the unit at this moment.

If sensor requires 24 V, it is necessary to lower power supply voltage for sensor slightly or secure power supply for sensor separately without going through SI unit so that sensor input voltage can be 24 V with actual loading (allowable voltage of power supply: 19.2 V to 28.8 V) glen or dual power supply is available.

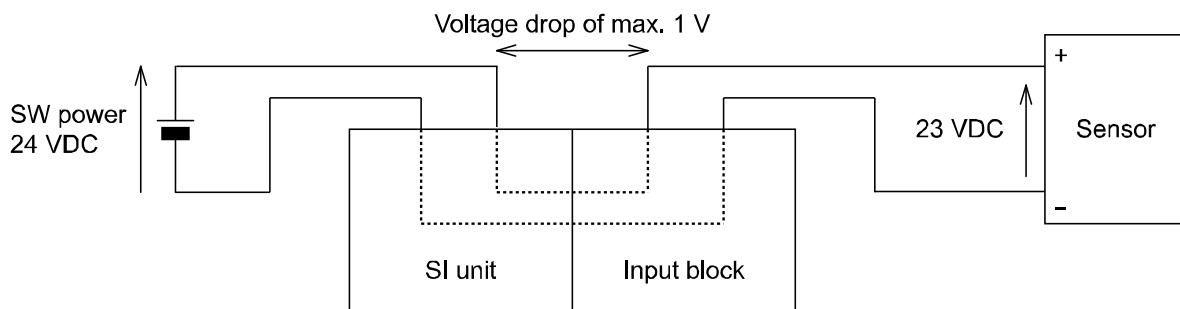

•Communication connector

M12 5-pin reverse (Socket)

Example of connected Bus Tee: TURCK VB2/FSW/FKW/FSW45 etc.

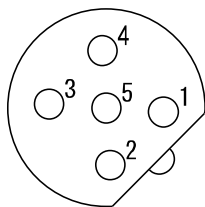

Pin No.	Description	Function
1	VP	Supply voltage for Terminating Resistor
2	A-N	Minus to send/receive data
3	DGND	Ground for Terminating Resistor
4	B-P	Plus to send/receive data
5	N.C.	Unused

•Power supply connector

M12 5-pin (Plug)

Example of connected cable: SMC EX500-AP0*0-S etc.

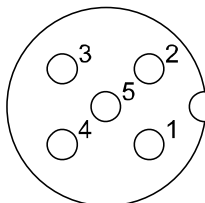

Pin No.	Description	Function
1	SV24 V	+24 V for solenoid valve.
2	SV0 V	0 V for solenoid valve
3	SW24 V	+24 V for SI unit and Input Block
4	SW0 V	0 V for SI unit and Input Block
5	FE	Ground

○Maintenance

Addition of Input Block

- Remove screws from End Plate.
- Mount attached tie rod.
- Connect additional Input Block.
- Connect End Plate and tighten removed screws by specified tightening torque. (0.6 Nm)

Exchange of SI unit

- Remove screws from End Plate and release connection of each unit.
- Replace old SI unit with new one. (Tie rod does not need to be removed.)
- Connect End Plate and tighten removed screws by specified tightening torque. (0.6 Nm)

Caution for maintenance

- (1) Be sure to turn-off all power supplies.
- (2) Be sure that there is no foreign object in any of units.
- (3) Be sure that gasket is lined properly.
- (4) Be sure that tightening torque is according to specification.

If these items are not kept, it may lead to the breakage of substrate or intrusion of liquid or dust into the units.

○Assembly and disconnection of unit

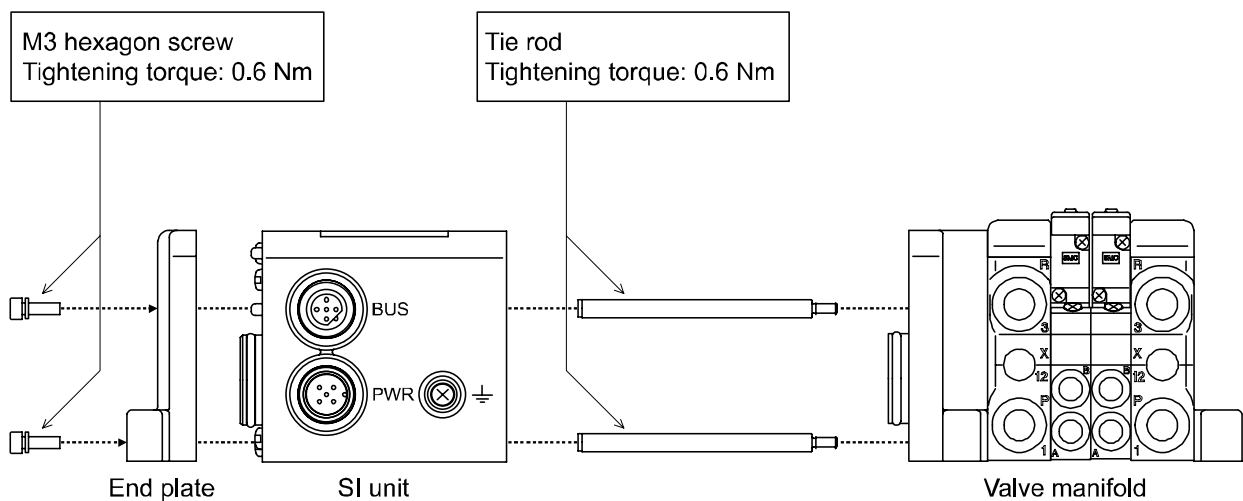

Setting

•LED display

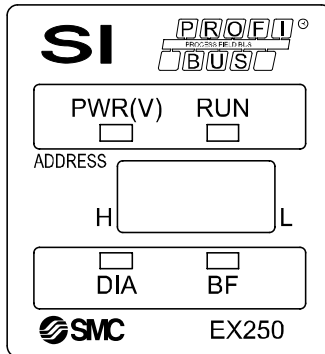

Indication	Contents
PWR(V)	Green lights up when power supply for solenoid valves is turned on. Disappear when solenoid valve power supply voltage decreases below 19V.
RUN	Green lights up during operation(when power supply for SI unit is turned on.)
DIA	Red lights up when some failure is detected by self-diagnosis.
BF	Red lights up when bus failure is detected.

•Address setting

Be sure to turn power supply off before setting the switches of SI unit. Switch installed in cover of SI unit is available for setting of address.

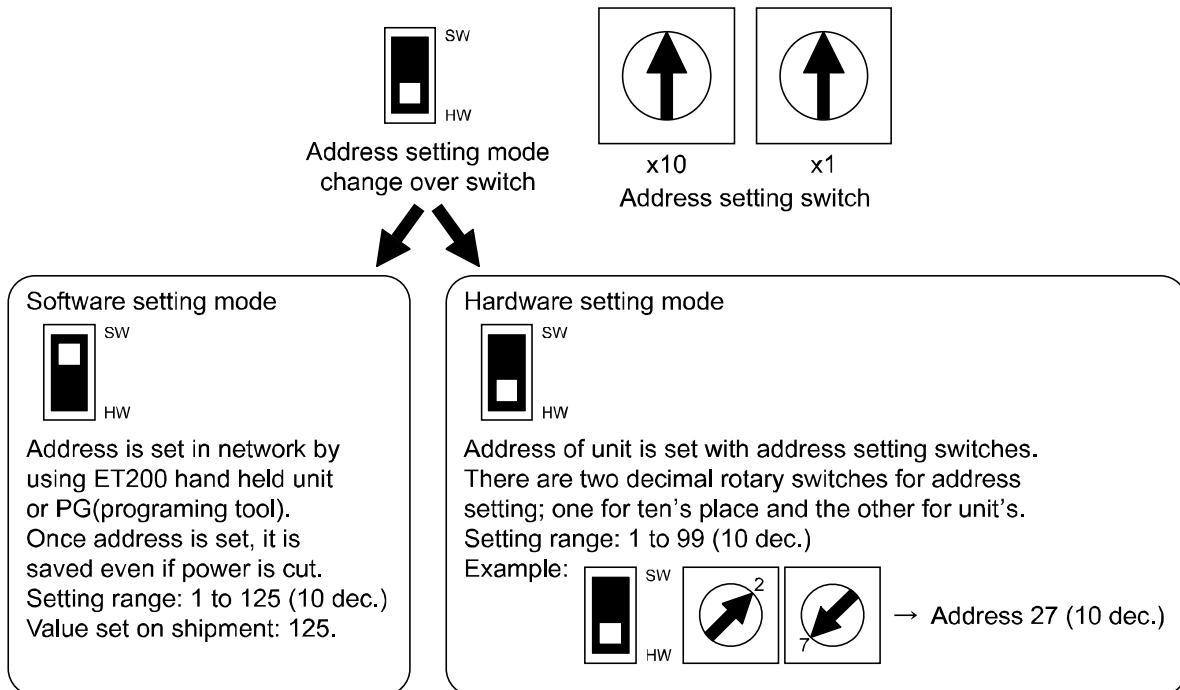

*: When software setting mode is selected, address setting switches are not effectual. Moreover, software setting mode and hardware setting mode differ in ID numbers of units. (See "I/O Configuration" (page 18) for details.)

•Diagnosis information

Diagnosis information of the SI unit is composed of 6 bytes standard diagnosis information and 7 bytes SI unit status information, 13 bytes in total, as specified in PROFIBUS DP.

When the SI unit is in a non-standard state, it will send an error message to the master as diagnosis information, and light up the DIA display.

SI unit status information is as follows.

Function	Contents
Surveillance of Solenoid valve power supply voltage	It detects when the voltage of the solenoid valve lowers to approximately 19 V or less.
Input block open fuse surveillance	Detection of communication error in A to D on the input side due to the broken fuse of the Input block.

Refer to PROFIBUS specifications and manual of the master, etc. for how to refer to diagnosis information on the master.

The composition of diagnosis information is as follows. (The value when it is normal is indicated. "X" means the value is changeable.)

Byte0: Station Status 1

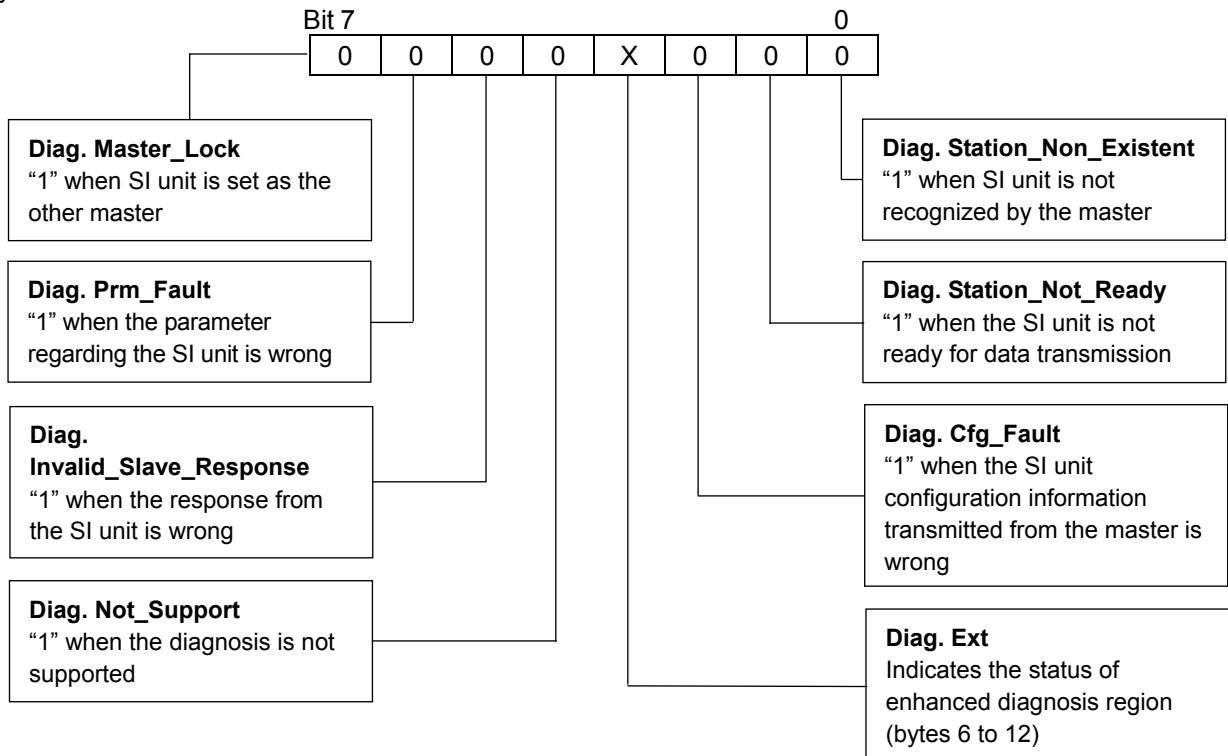

Byte1: Station Status 2

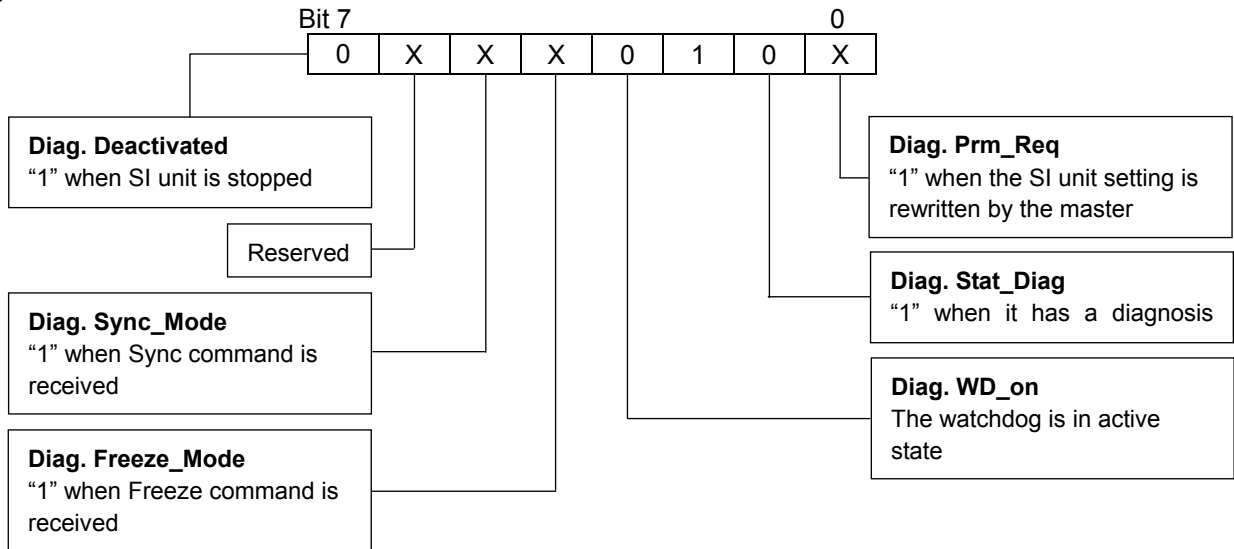

Byte2: Station Status 3

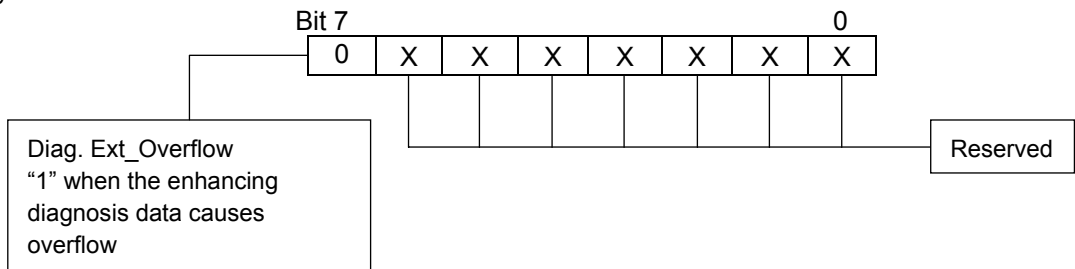

Byte3: Diag.Master_Add
Indicates the master address.

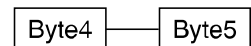

SW setting mode: 14h — 08h

Byte4, 5: Ident_Number
Indicates ID No. of SI unit.

HW setting mode: 14h — 09h

Byte6: Diag.Header
Indicates how many bits the enhancing diagnosis data has. (7 byte: fixed)

Byte7: SI unit status information

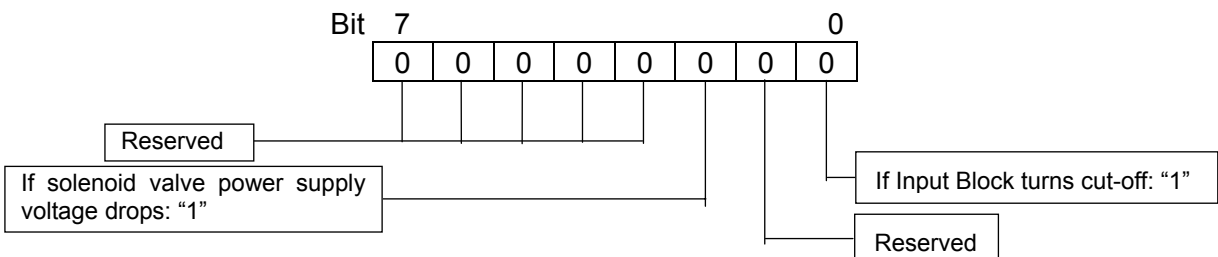

Byte8 to 12: Reserved (All 00h)

•Set-up steps

In PROFIBUS DP, a device database file called the Generic Station Description (GSD) file provides configuration information specific to the device (ID number, data format, baud rate...).

The GSD file of the product depends on the address setting mode (selected by the address setting mode switch).

GSD file: SMCA1409.gsd (In hardware setting mode)
 SMCA1408.gsd (In software setting mode)

The procedure to set the master to enable the product is shown using SIEMENS STEP7 as an example.

- (1) Copy the GSD file of the product (SMCA140*.gsd) to a directory of your choice.
- (2) Start up STEP7, and execute "Options" – "Install GSD Files" from the HW Config tools.
- (3) Open "View" – "Catalog", and check that the "Valves" icon has been added to "PROFIBUS DP" – "Additional Field Devices". Drag and drop "EX250-SPR1(HW)" (file for hardware setting mode) or "EX250-SPR1(SW)" (file for software setting mode) to add it to the PROFIBUS DP line.
- (4) Download the above setting to PLC.
 Click "Save & Compile". After completion,
 Click "Download to Module".
 It is set completion in the above.

It is set completion in the above.

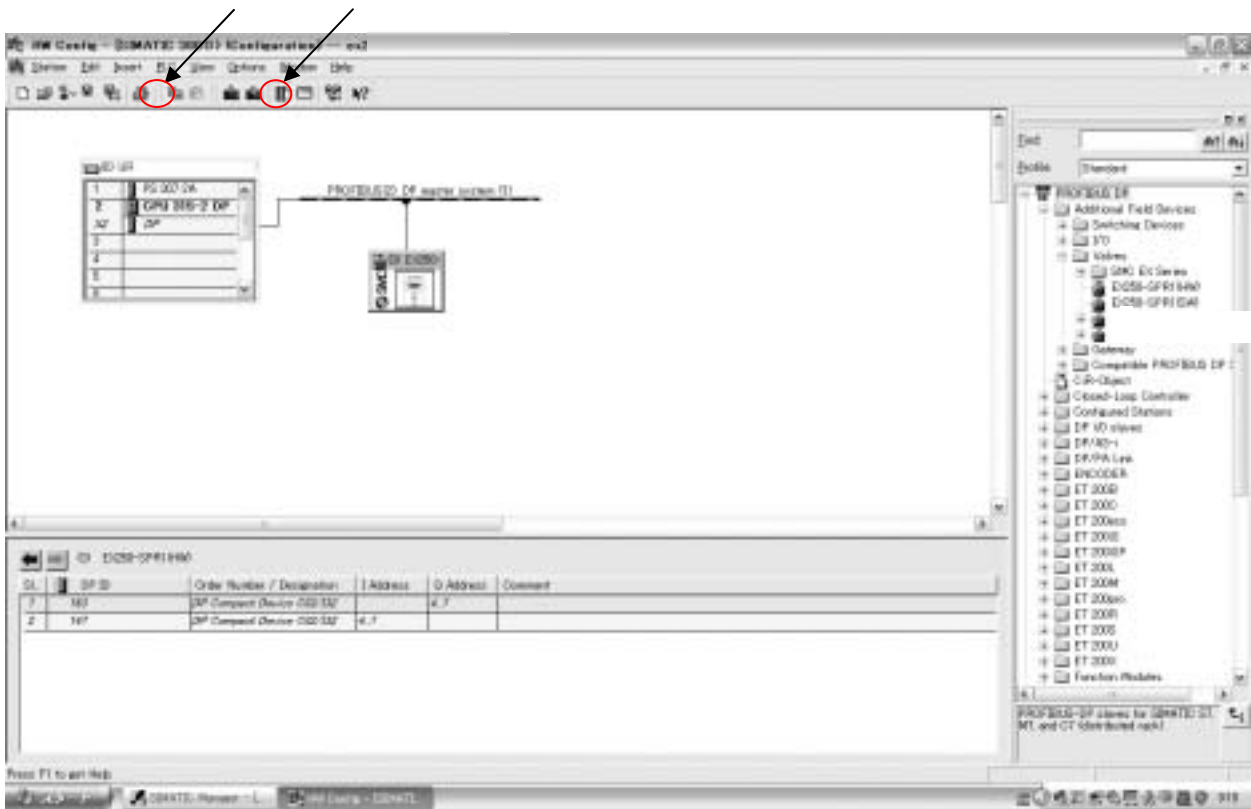

•I/O Configuration

I/O configuration of SI unit is shown below. (Refer to manuals or other information of master for details such as definition of numbers.)

Byte (Slot)	No.	Type	Length	Unit
0	163 (A3H)	Output	4	Byte
1	147 (93H)	Input	4	Byte

•Assignment of I/O No.

Correspondence between output data and valve manifold

Output data

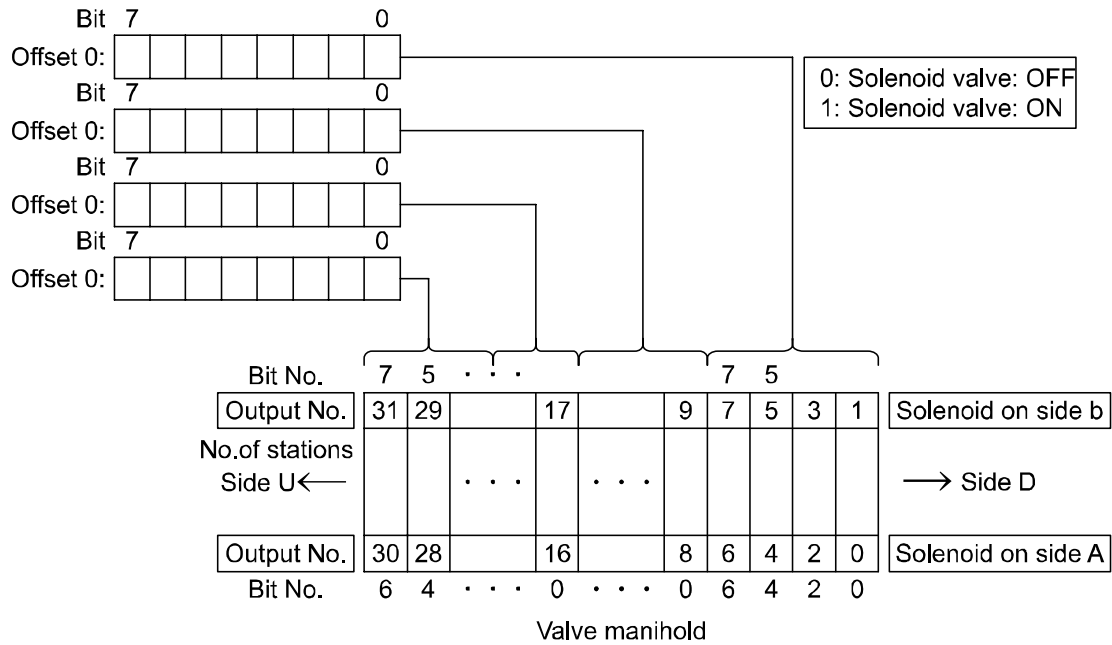

- *: Output numbers are assigned to stations from side D to U of manifold in order. (See manual of each valve manifold for the directions of side D and U)
- *: Standard manifold is wired in double. Output numbers are assigned to side A and B alternatively. In case of single solenoid valve, output on side B is free. (Refer to fig. a)
- *: Mixed (single and double) wiring is available as long as wiring specifications designate it. This allows output numbers to be specified without having free output. (Refer to fig. b)
- *: Each bit of data sent from master (4 bytes) shows ON/OFF (0: OFF, 1: ON) of solenoid valve. Starting from LSB of the first byte (Offset0), output numbers are assigned to all the bits in numeric order.

fig. a

	No.	Station No.	No.	
Double	4	3	5	
Single	2	2	3	free
Double	0	1	1	

fig. b

	No.	Station No.	No.
Double	3	3	4
Single	2	2	-
Double	0	1	1

•Correspondence between output data and valve manifold

Input data

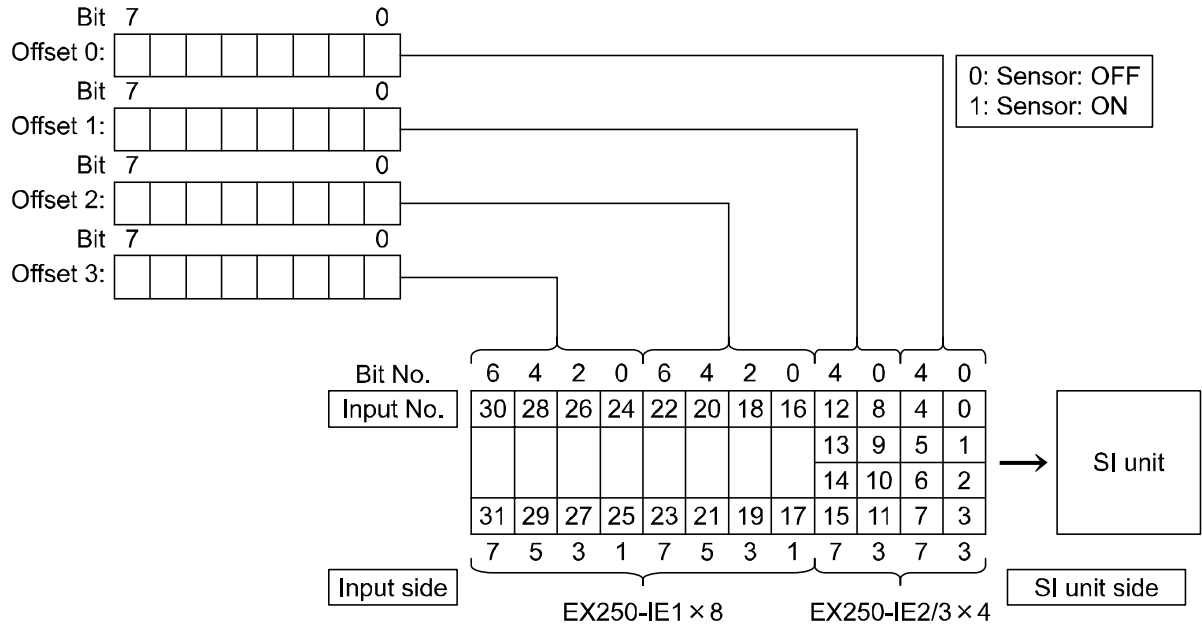

*: Input numbers are assigned to stations from SI unit side to input side in order.

*: Each bit of data read into master 4 bytes shows ON/OFF of sensor connected to input block.

Starting from LSB of first byte (Offset 0), input numbers are assigned to all bits in numeric order.

Example Configuration:

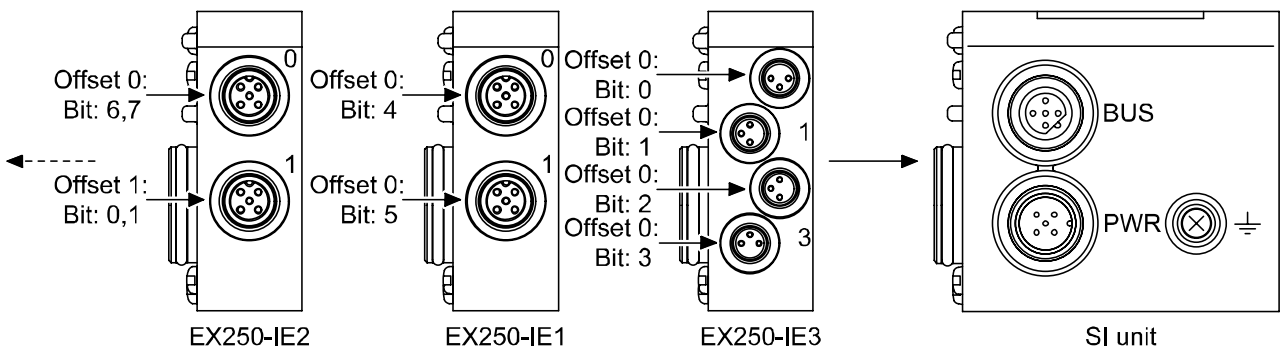

Specification of Input Blocks: (Please refer to Operation Manual EX##-OME0004)

- For EX250-IE1 (M12, 2 Inputs), two bits are used for input.
- For EX250-IE2/3 (M12/8, 4 inputs), four bits are used for input.

Troubleshooting

Troubleshooting flow chart

If the SI unit malfunctions, select the specific trouble with the flow chart stated below.

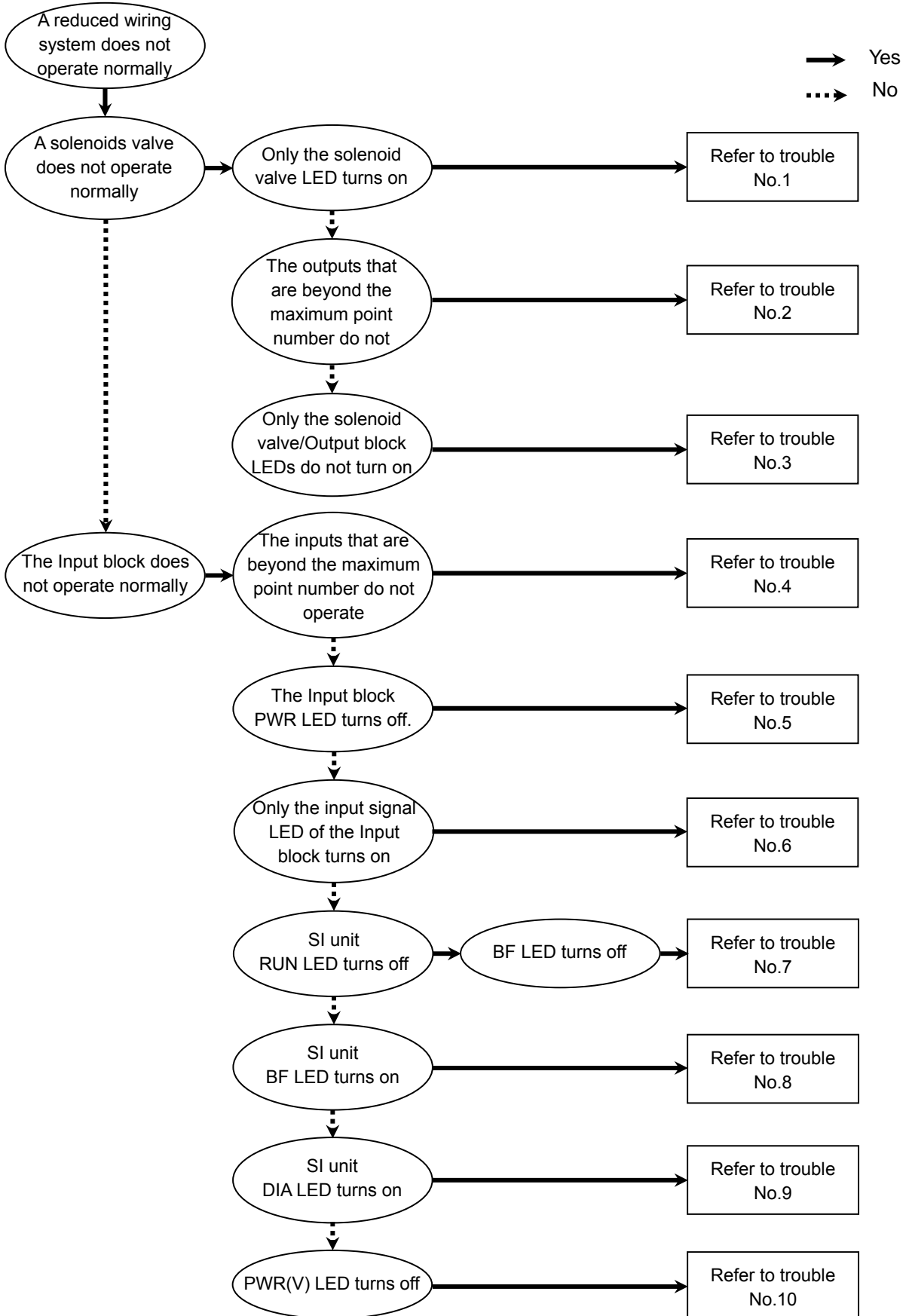

Troubleshooting table

Trouble No.1

Trouble	Possible cause	Investigation method of cause	Remedy
Only the solenoid valve LED turn on.	Solenoid valve failure.	Check the troubleshooting for the solenoid valve.	Same as left.

Trouble No.2

Trouble	Possible cause	Investigation method of cause	Remedy
The outputs that are beyond the maximum point number do not operate.	Inadequate total number of outputs from the solenoid valves and Output block connected with the SI unit.	Check if the total number of outputs is 32 or less (24 for the solenoid valve VQC series).	Delete unused extra outputs from the manifold, and ensure there are 32 outputs or less (24 outputs or less for the VQC series solenoid valve).

Trouble No.3

Trouble	Possible cause	Investigation method of cause	Remedy
Only the solenoid valve/Output block LEDs do not turn on	Incorrect wiring for the power supply for solenoid valve and the power supply.	Check that the power supply cable for the solenoid valve is not broken, and that the connection between the power supply cable and connector has not loosened.	Review the connection condition of the power supply cable. (If the cable is broken, replace it with a new one.)
		Check that there is no incorrect wiring of the power supply cable.	Review the wiring condition of the power supply cable.
	Failure of the power supply for the solenoid valve.	Check the supply voltage to the power supply for the solenoid valve.	Supply 24 VDC +10%/-5% to the power supply for the solenoid valve.
	Incorrect connection between the SI unit and the solenoid valve and/or Output block.	Check that the bolt joining the SI unit with the solenoid valve and Output block has not loosened.	Tighten the bolts by hand so that there is no gap between the SI unit and the solenoid valve and/or Output block. Tighten at the specified torque. (Tightening torque: 0.6 Nm)
		Check if the Output block (for high wattage and load and low wattage and load) and Power block are mounted in the right position.	Review the position of the Output block and Power block.
Intrusion of liquids such as water.	Check that unused connectors of the Output block and Power block are plugged with waterproof caps.	If liquid such as water has got into the Output block and/or Power block, replace the Output block and Power block with new ones.	

Trouble No.3

Trouble	Possible cause	Investigation method of cause	Remedy
Only the solenoid valve/Output block LEDs do not turn on	Incorrect connection of the load with the Output block.	Check that the output load cable is not broken, and that the connection between the output load and connector has not loosened.	Review the connecting condition of the output load. (If the cable is broken, replace it with a new one.)
		Check if the specifications of the SI unit match those of the Output load (+ common, - common).	Use - common with the output load for the PNP output.
	Inconsistent polarity between the solenoid valve (VQC1000/2000) and Output block.	Check if the specifications of the SI unit match those of the solenoid valve and output block (+ common, - common).	Use - common with the solenoid valve and Output block suitable for the PNP output of the SI unit.
	Failure of the solenoid valve and/or Output block.	Check the troubleshooting for the solenoid valve.	Same as left.
Replace the SI unit with new one and operate to check the normal operation recovers.		Replace the SI unit with new one.	

Trouble No.4

Trouble	Possible cause	Investigation method of cause	Remedy
The inputs that are beyond the maximum point number do not operate.	Inadequate total number of inputs from the Input block connected with the SI unit.	Check if the total number of inputs is 32 or less.	Eliminate extra unused inputs from the manifold to ensure the number of inputs is 32 or less.

Trouble No.5

Trouble	Possible cause	Investigation method of cause	Remedy
The Input block PWR LED turns off.	Failure of the power supply for the input block and control of the SI unit.	Check the supply voltage to the power supply for the input and control of the SI unit.	Supply 24 VDC \pm 10% to the power supply for the input block and control.
	Incorrect connection between the SI unit and Input block.	Check that the bolt joining the SI unit and Input block has not loosened.	Tighten the bolts by hand so that there is no gap between the SI unit and Input block. Tighten at the specified torque. (Tightening torque: 0.6 Nm)
	The Input block fuse has melted.	Check if the fuse of the Input block has melted.	Remove the cause of the short-circuit and replace the fuse with new one.
	Intrusion of liquids such as water.	Check that unused connectors of the Input block are plugged with waterproof caps.	If liquid such as water has got into the input, replace the Input block with new one.
	Input block failure.	Replace the Input block with new one and operate to check the normal operation recovers.	Replace the Input block with new one.

Trouble No.6

Trouble	Possible cause	Investigation method of cause	Remedy
Only the input signal LED of the Input block turns on	Inconsistent polarity in sensors.	Check the specifications of the Input block (NPN, PNP) match those of the sensor.	Make a suitable combination of Input block and sensor.
	Incorrect connection of the sensor.	Check that the sensor cable is not broken and that the connection between the sensor cable and connector has not loosened.	Review the connection condition of the sensor cable. (If the cable is broken, replace it with new one.)
	Sensor failure.	Check the troubleshooting of the sensor.	Same as left.

Trouble No.7

Trouble	Possible cause	Investigation method of cause	Remedy
The SI unit PWR LED turns off.	Incorrect wiring of the power supply for control and input block of the product.	Confirm there is no incorrect connection between input and SI unit controlling part power supply and SI unit power supply connector.	Review the connection condition of the power supply cable. (If the cable is broken, replace it with a new one.)
	Failure of the power supply for control and input block of the product.	Check the condition of the power supply for control and input block of the product.	Supply DC24 V+/-10% to the power supply for control and input block of the product.

Trouble No.8

Trouble	Possible cause	Investigation method of cause	Remedy
BF LED turns on.	PROFIBUS communication error.	Confirm the signal line from PLC is connected correctly.	Review the connection condition of the power supply cable. (If the cable is broken, replace it with new one.)
		Address setting error: [In hardware mode] Confirm the address setting of DIP switch is performed correctly. [In software mode] Confirm the address set through network is correct.	Review the settings of the product.
		Check the length of communication line in respect to the communication speed, presence of the terminating resistor at both ends of transmission line and use of PROFIBUS dedicated cable.	Review wiring and settings.
		Confirm there is no equipment and high voltage line which might generate a noise around the communication line.	Take a proper measure such as by separating the communication line from the noise source.

Trouble No.9

Trouble	Possible cause	Investigation method of cause	Remedy
Others (DIA LED turns on.)	Decreased power supply voltage for solenoid valves.	Check supply voltage of the solenoid valve power supply. (Information about the solenoid valve power supply is sent to the PLC as extended diagnostic information.) Check it in the programming software. (A supply voltage of approx. 19 V or less is detected.).	Supply 24 VDC +10%/-5% to the power supply for the solenoid valve.
	Input block fuse blown/ broken.	Check if the fuse of the input block has melted. (Information about the solenoid valve power supply is sent to the PLC as extended diagnostic information.) Check it in the programming software.	Replace the fuse of the Input block.

Trouble No.10

Trouble	Possible cause	Investigation method of cause	Remedy
The "PWR(V)" LED of the product turns off.	Incorrect wiring for the power supply for solenoid valve and the power supply.	Check if the switch setup is done properly.	Review the connection condition of the power supply cable. (If the cable is broken, replace it with a new one.)
		Check if the correct IP address is assigned by the DHCP server.	Review the wiring condition of the power supply cable.
	Failure of the power supply for the solenoid valve	Check supply voltage of the solenoid valve power supply.	Supply DC24 V+10%/-5% to the power supply for control and inputs of the product.

Specifications

■ Specifications

General specification

Item	Specification
Operating ambient temp.	-10 to +50 °C
Operating ambient humidity	35 to 85%RH (No dew condensation)
Storage ambient temp.	-20 to +60 °C
Withstand voltage	500 VAC for 1 min.
Insulation resistance	500 VDC 10 MΩ or more
Operating environment	No corrosive gas
Pollution degree	Pollution degree 3
Enclosure	IP67
Applicable standard	UL/CSA, CE

Electrical specification

Item	Specification
Power Voltage range, current consumption	Power for SI/Input Block Current consumption 19.2 to 28.8 VDC Depending on the number of Input Block stations and sensor specifications: 1.1 A or less (Inside SI unit: 0.1 A or less)
	Power for solenoid valve Current consumption 22.8 to 26.4 VDC Depending on number of solenoid valve station and specifications: 2.0 A or less
Solenoid valve connection specification	Output type Source / PNP (negative common)
	Connection load Solenoid valve with surge voltage suppressor of 24 VDC and 1.5 W or less (manufactured by SMC)
	Insulation type Photo coupler type
	Residual Voltage 0.3 VDC or less

Communication specification

Item	Specification
Protocol	PROFIBUS DP (EN50170, EN50254)
BUS Interface	EIA RS-485
Communication form	Token passing
Transmission speed	9.6/19.2/45.45/93.75/187.5/500/1500/12000 kbps
Transmission media	STP cable
Connect node	Max. 125 station
Network topology	Bus, tree, star
Cable length	Max. 23 km (Repeater needed)
Freeze mode	Available
Sync mode	Available
Input point	Max. 32 points
Output point	Max. 32 points
ID number	1408 hex (SW setting mode) 1409 hex (HW setting mode)

Applicable solenoid valves

Representative series	Applicable series
VQC series	VQC1000, VQC2000, VQC4000
SV series	SV1000, SV2000, SV3000 (Tie-rod base manifold)
S0700 series	S0700

Dimensions

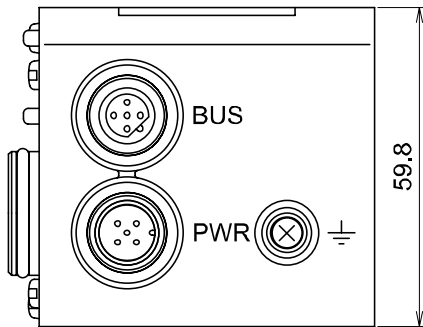
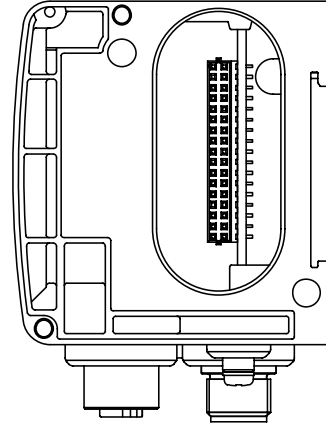
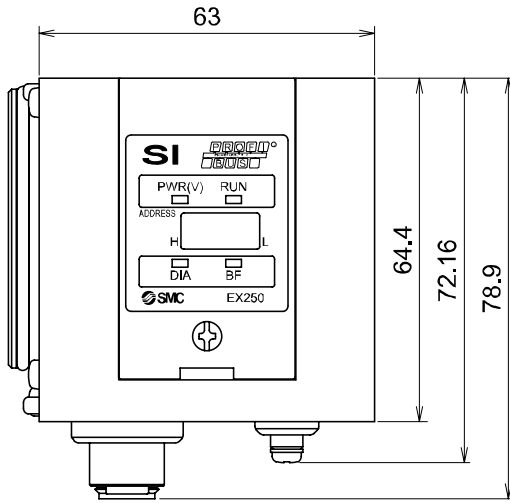

Revision history

A: Add some contents
B: Correct an error in writing
C: Make an overall revision
D: Correct an error in writing
E: Revision

SMC Corporation

Akihabara UDX 15F,
4-14-1, Sotokanda, Chiyoda-ku, Tokyo 101-0021, JAPAN
Phone: +81 3-5207-8249 Fax: +81 3-5298-5362
URL <http://www.smcworld.com>

Note: Specifications are subject to change without prior notice and any obligation on the part of the manufacturer.

© 2009-2011 SMC Corporation All Rights Reserved



No.EX##-OME0014-E