



Operation Manual

PRODUCT NAME

SI unit for DeviceNet™

MODEL / Series / Product Number

EX120-SDN1(-X2/-X26/-X77)
EX121-SDN1(-X2/-X26/-X77)
EX122-SDN1(-X2/-X26/-X77)
EX124U/D-SDN1(-X2/-X26/-X77)

SMC Corporation



Contents

Safety Instructions	2
How to Order	7
Summary of Product elements	8
Installation and wiring	10
Installation	10
Wiring	10
LED indication and settings	13
DeviceNet™ Objects	21
Troubleshooting and Maintenance	30
Specifications	40
Specifications	40
Dimensions	42
Accessories	45

Safety Instructions

These safety instructions are intended to prevent hazardous situations and/or equipment damage. These instructions indicate the level of potential hazard with the labels of "Caution", "Warning" or "Danger". They are all important notes for safety and must be followed in addition to International standards (ISO/IEC) *1) and other safety regulations.

- *1) ISO 4414: Pneumatic fluid power -- General rules relating to systems.
- ISO 4413: Hydraulic fluid power -- General rules relating to systems.
- IEC 60204-1: Safety of machinery -- Electrical equipment of machines. (Part 1: General requirements)
- ISO 10218-1992: Manipulating industrial robots -Safety.
- etc.

-  **Caution** : CAUTION indicates a hazard with a low level of risk which, if not avoided, could result in minor or moderate injury.
-  **Warning** : WARNING indicates a hazard with a medium level of risk which, if not avoided, could result in death or serious injury.
-  **Danger** : DANGER indicates a hazard with a high level of risk which, if not avoided, will result in death or serious injury.

Warning

1. The compatibility of the product is the responsibility of the person who designs the equipment or decides its specifications.

Since the product specified here is used under various operating conditions, its compatibility with specific equipment must be decided by the person who designs the equipment or decides its specifications based on necessary analysis and test results. The expected performance and safety assurance of the equipment will be the responsibility of the person who has determined its compatibility with the product. This person should also continuously review all specifications of the product referring to its latest catalog information, with a view to giving due consideration to any possibility of equipment failure when configuring the equipment.

2. Only personnel with appropriate training should operate machinery and equipment.

The product specified here may become unsafe if handled incorrectly. The assembly, operation and maintenance of machines or equipment including our products must be performed by an operator who is appropriately trained and experienced.

3. Do not service or attempt to remove product and machinery/equipment until safety is confirmed.

1. The inspection and maintenance of machinery/equipment should only be performed after measures to prevent falling or runaway of the driven objects have been confirmed.
2. When the product is to be removed, confirm that the safety measures as mentioned above are implemented and the power from any appropriate source is cut, and read and understand the specific product precautions of all relevant products carefully.
3. Before machinery/equipment is restarted, take measures to prevent unexpected operation and malfunction.

4. Contact SMC beforehand and take special consideration of safety measures if the product is to be used in any of the following conditions.

1. Conditions and environments outside of the given specifications, or use outdoors or in a place exposed to direct sunlight.
2. Installation on equipment in conjunction with atomic energy, railways, air navigation, space, shipping, vehicles, military, medical treatment, combustion and recreation, or equipment in contact with food and beverages, emergency stop circuits, clutch and brake circuits in press applications, safety equipment or other applications unsuitable for the standard specifications described in the product catalog.
3. An application which could have negative effects on people, property, or animals requiring special safety analysis.
4. Use in an interlock circuit, which requires the provision of double interlock for possible failure by using a mechanical protective function, and periodical checks to confirm proper operation.

Caution

The product is provided for use in manufacturing industries.

The product herein described is basically provided for peaceful use in manufacturing industries. If considering using the product in other industries, consult SMC beforehand and exchange specifications or a contract if necessary.
If anything is unclear, contact your nearest sales branch.

Limited warranty and Disclaimer/Compliance Requirements

The product used is subject to the following "Limited warranty and Disclaimer" and "Compliance Requirements".

Read and accept them before using the product.

Limited warranty and Disclaimer

1. The warranty period of the product is 1 year in service or 1.5 years after the product is delivered. ^{*2)}
Also, the product may have specified durability, running distance or replacement parts. Please consult your nearest sales branch.
2. For any failure or damage reported within the warranty period which is clearly our responsibility, a replacement product or necessary parts will be provided.
This limited warranty applies only to our product independently, and not to any other damage incurred due to the failure of the product.
3. Prior to using SMC products, please read and understand the warranty terms and disclaimers noted in the specified catalog for the particular products.

*2) Vacuum pads are excluded from this 1 year warranty.

A vacuum pad is a consumable part, so it is warranted for a year after it is delivered.

Also, even within the warranty period, the wear of a product due to the use of the vacuum pad or failure due to the deterioration of rubber material are not covered by the limited warranty.

Compliance Requirements

1. The use of SMC products with production equipment for the manufacture of weapons of mass destruction (WMD) or any other weapon is strictly prohibited.
2. The exports of SMC products or technology from one country to another are governed by the relevant security laws and regulation of the countries involved in the transaction. Prior to the shipment of a SMC product to another country, assure that all local rules governing that export are known and followed.

Operator

- ◆ This operation manual is intended for those who have knowledge of machinery using pneumatic equipment, and have sufficient knowledge of assembly, operation and maintenance of such equipment. Only those persons are allowed to perform assembly, operation and maintenance.
- ◆ Read and understand this operation manual carefully before assembling, operating or providing maintenance to the product.

■ Safety Instructions

Warning

- Do not disassemble, modify (including changing the printed circuit board) or repair.
An injury or failure can result.
- Do not operate the product outside of the specifications.
Do not use for flammable or harmful fluids.
Fire, malfunction, or damage to the product can result.
Verify the specifications before use.
- Do not operate in an atmosphere containing flammable or explosive gases.
Fire or an explosion can result.
This product is not designed to be explosion proof.
- If using the product in an interlocking circuit:
 - Provide a double interlocking system, for example a mechanical system
 - Check the product regularly for proper operationOtherwise malfunction can result, causing an accident.
- The following instructions must be followed during maintenance:
 - Turn off the power supply
 - Stop the air supply, exhaust the residual pressure and verify that the air is released before performing maintenanceOtherwise an injury can result.

Caution



- After maintenance is complete, perform appropriate functional inspections.
Stop operation if the equipment does not function properly.
Safety cannot be assured in the case of unexpected malfunction.
- Provide grounding to assure the safety and noise resistance of the Serial System.
Individual grounding should be provided close to the product with a short cable.

■NOTE

○Follow the instructions given below when designing, selecting and handling the product.

●The instructions on design and selection (installation, wiring, environment, adjustment, operation, maintenance, etc.) described below must also be followed.

*Product specifications

- When conformity to UL is necessary the SI unit must be used with a UL1310 Class2 power supply.
- The SI unit is a  approved product only if they have a  mark on the body.
- Use the specified voltage.
Otherwise failure or malfunction can result.
- Reserve a space for maintenance.
Allow sufficient space for maintenance when designing the system.
- Do not remove any nameplates or labels.
This can lead to incorrect maintenance, or misreading of the operation manual, which could cause damage or malfunction to the product.
It may also result in non-conformity to safety standards.

●Product handling

*Installation

- Do not drop, hit or apply excessive shock to the fieldbus system.
Otherwise damage to the product can result, causing malfunction.
- Tighten to the specified tightening torque.
If the tightening torque is exceeded the mounting screws may be broken.
IP67 protection cannot be guaranteed if the screws are not tightened to the specified torque.
- Never mount a product in a location that will be used as a foothold.
The product may be damaged if excessive force is applied by stepping or climbing onto it.

*Wiring

- Avoid repeatedly bending or stretching the cables, or placing heavy load on them.
Repetitive bending stress or tensile stress can cause breakage of the cable.
- Wire correctly.
Incorrect wiring can break the product.
- Do not perform wiring while the power is on.
Otherwise damage to the fieldbus system and/or I/O device can result, causing malfunction.
- Do not route wires and cables together with power or high voltage cables.
Otherwise the fieldbus system and/or I/O device can malfunction due to interference of noise and surge voltage from power and high voltage cables to the signal line.
Route the wires (piping) of the fieldbus system and/or I/O device separately from power or high voltage cables.
- Confirm proper insulation of wiring.
Poor insulation (interference from another circuit, poor insulation between terminals, etc.) can lead to excess voltage or current being applied to the product, causing damage.
- Take appropriate measures against noise, such as using a noise filter, when the fieldbus system is incorporated into equipment.
Otherwise noise can cause malfunction.

*Environment

- Select the proper type of protection according to the environment of operation.

In case of IP20, avoid use in the place where water and oil scatter.

IP65 protection is achieved when the following conditions are met.

(1) The units are connected properly with fieldbus cable with M12 connector and power cable with M12 (M8) connector.

(2) Suitable mounting of each unit and manifold valve.

If using in an environment that is exposed to water splashes, please take measures such as using a cover.

If the product is to be used in an environment containing oils or chemicals such as coolant or cleaning solvent, even for a short time, it may be adversely affected (damage, malfunction etc.).

- Do not use the product in an environment where corrosive gases or fluids could be splashed.

Otherwise damage to the product and malfunction can result.

- Do not use in an area where surges are generated.

If there is equipment which generates a large amount of surge (solenoid type lifter, high frequency induction furnace, motor, etc.) close to the fieldbus system, this may cause deterioration or breakage of the internal circuit of the fieldbus system. Avoid sources of surge generation and crossed lines.

- When a surge-generating load such as a relay or solenoid is driven directly, use an fieldbus system with a built-in surge absorbing element.

Direct drive of a load generating surge voltage can damage the fieldbus system.

- The product is CE marked, but not immune to lightning strikes. Take measures against lightning strikes in the system.

- Prevent foreign matter such as remnant of wires from entering the fieldbus system to avoid failure and malfunction.

- Mount the product in a place that is not exposed to vibration or impact.

Otherwise failure or malfunction can result.

- Do not use the product in an environment that is exposed to temperature cycle.

Heat cycles other than ordinary changes in temperature can adversely affect the inside of the product.

- Do not expose the product to direct sunlight.

If using in a location directly exposed to sunlight, shade the product from the sunlight.

Otherwise failure or malfunction can result.

- Keep within the specified ambient temperature range.

Otherwise malfunction can result.

- Do not operate close to a heat source, or in a location exposed to radiant heat.

Otherwise malfunction can result.

*Adjustment and Operation

- Set the switches by using a sharp-pointed screwdriver etc.

It may damage set switches.

- Perform settings suitable for the operating conditions.

Incorrect setting can cause operation failure.

For details of each setting, refer to page 13 to 20 of this manual.

- Please refer to the PLC manufacturer's manual etc. for details of programming and addresses.

For the PLC protocol and programming refer to the relevant manufacturer's documentation.

*Maintenance

- Turn off the power supply, stop the supplied air, exhaust the residual pressure and verify the release of air before performing maintenance.

There is a risk of unexpected malfunction.

- Perform regular maintenance and inspections.

There is a risk of unexpected malfunction.

- After maintenance is complete, perform appropriate functional inspections.

Stop operation if the equipment does not function properly.

Otherwise safety is not assured due to an unexpected malfunction or incorrect operation.

- Do not use solvents such as benzene, thinner etc. to clean the each unit.

They could damage the surface of the body and erase the markings on the body.

Use a soft cloth to remove stains.

For heavy stains, use a cloth soaked with diluted neutral detergent and fully squeezed, then wipe up the stains again with a dry cloth.

How to Order

EX120-SDN1

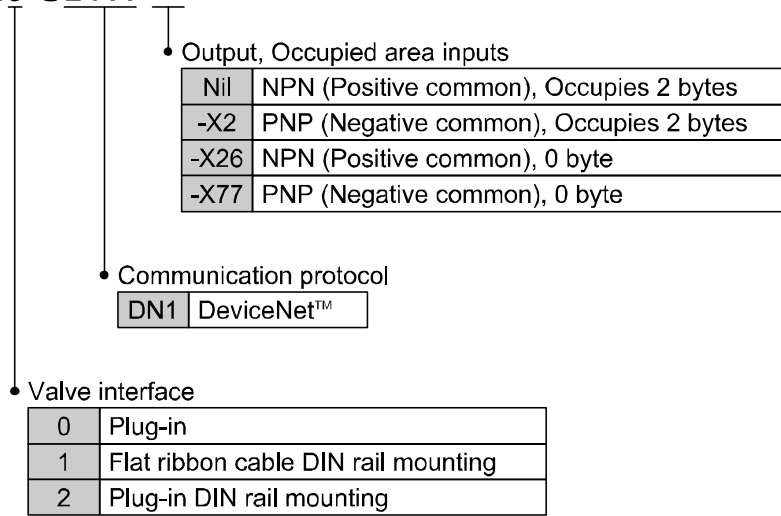

EX124 U -SDN1

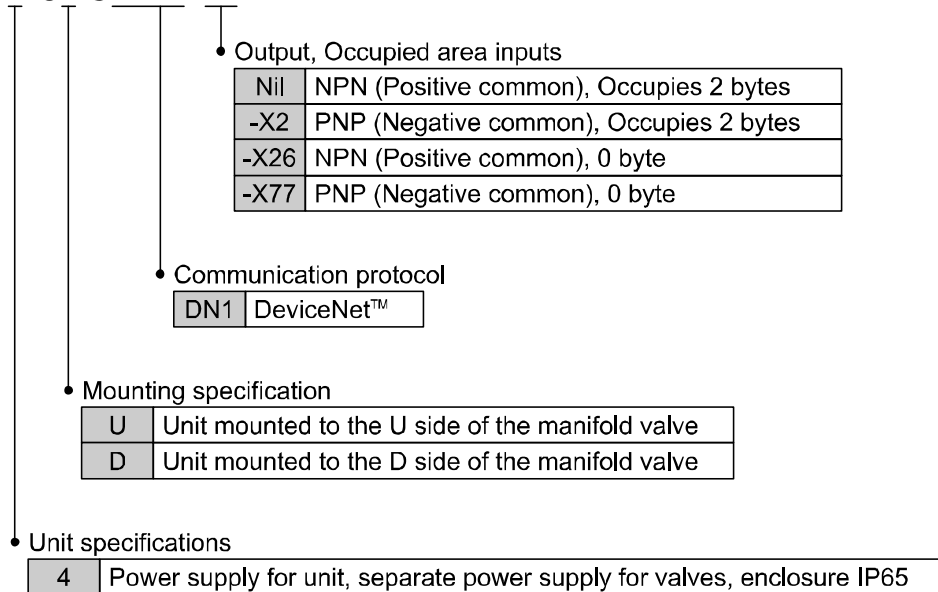

Summary of Product Parts

○EX120-SDN1(-X2/-X26/-X77)

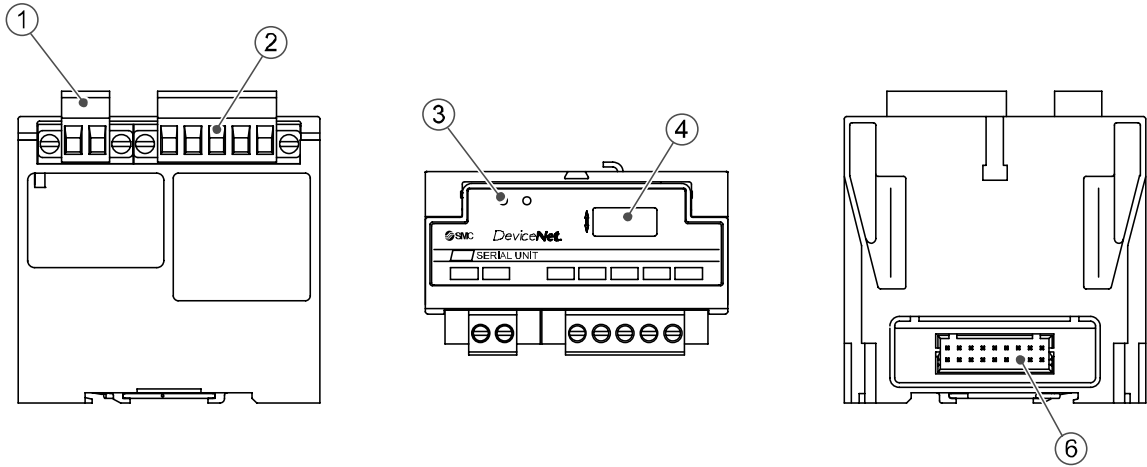

○EX121-SDN1(-X2/-X26/-X77)

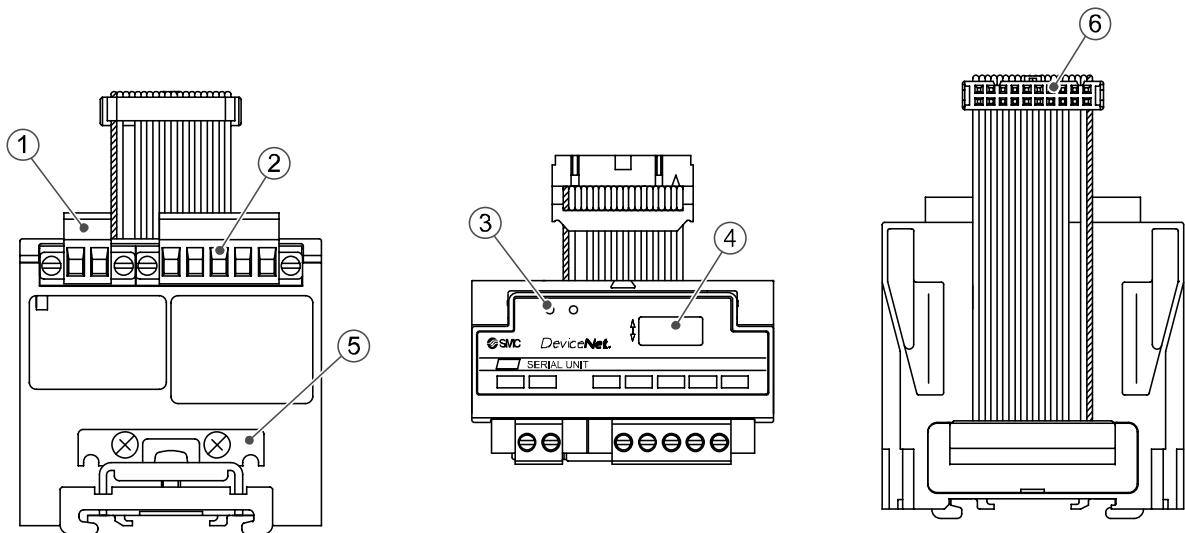

○EX122-SDN1(-X2/-X26/-X77)

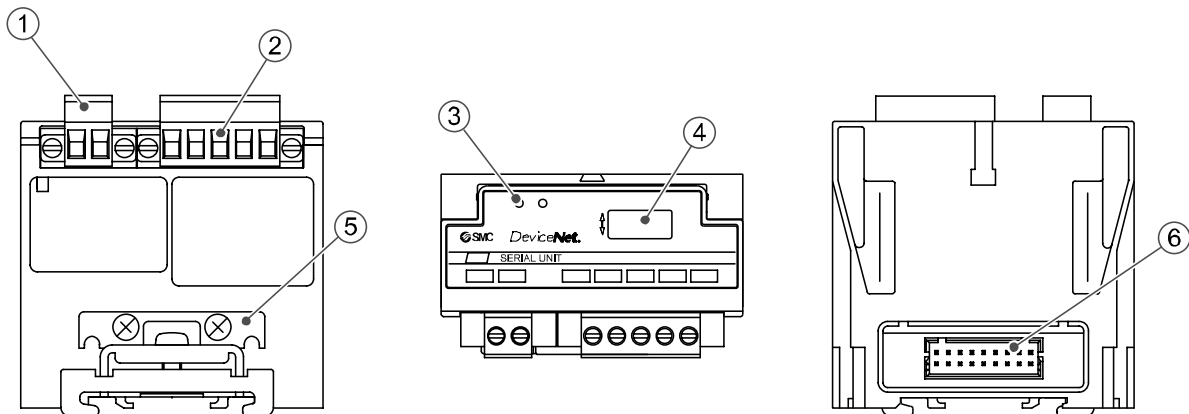

○EX124U/D-SDN1(-X2/-X26/-X77)

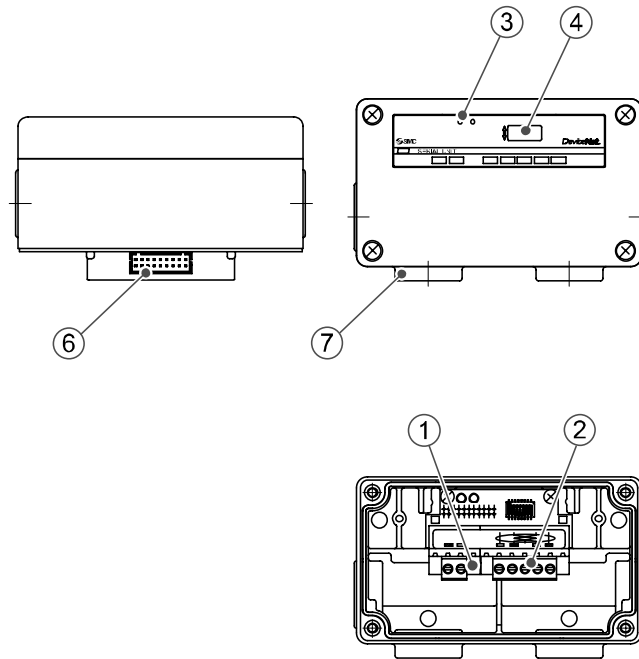

Inside the housing cover

No.	Element	Description
1	Power supply connector	The power supply connector, provided as an accessory, is used to supply the power for the solenoid valves. *1 EX12*-SDN1/-X2: Green EX12*-SDN1-X26/-X77: Grey
2	Communication connector	The communication connector is used to connect to the DeviceNet™ line. *1 EX12*-SDN1/-X2: Green EX12*-SDN1-X26/-X77: Grey
3	Display	Displays the status of the unit with LEDs.
4	Switch setting	For performing the address/communication speed setting etc.
5	Mounting bracket	For mounting to a DIN rail.
6	Output connector	The output connector is used to connect the valve manifold.
7	Conduit port (4xG1/2)	Port used for wiring the EX124U/D-SDN1/-X2/-X26/-X77. *1

Accessory

Round head screw (M4x10) with spring washer (EX124U/D-SDN1 only)	Connects the SI unit to the valve manifold. (4 pcs.)
--	--

*1: Refer to "Wiring" on page 10 of this operation manual for applicable connectors.

*2: Refer to "LED display and Settings" on page 13 of this operation manual for the LED display and settings.

Installation and wiring

■ Installation

Connect the valve manifold to the SI unit when installing the SI unit.
Refer to the catalogue for the valve manifold dimensions.

■ Wiring

○ Communication wiring

MSTB2, 5/5-STF-5, 08AU connectors manufactured by Phoenix Contact are attached to the SI unit for mounting on the cable.

The connector screws should be tightened securely with a tightening torque of 0.5 to 0.6 Nm.

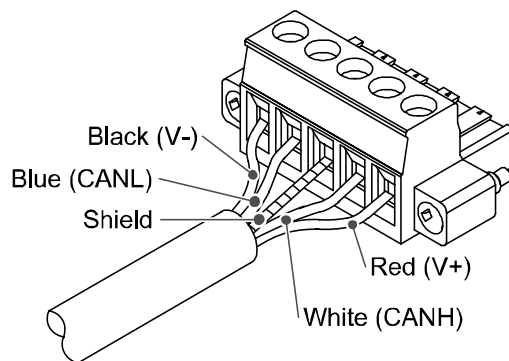

Communication connector

Terminal	Wire colour	Connection
V-	Black	(-) side of DeviceNet™ power supply cable
CANL	Blue	Low side of communication cable
FG(DRAIN)	-	Ground / Shield wire
CANH	White	High side of communication cable
V+	Red	(+) side of DeviceNet™ power supply cable

Note

Wiring should be carried out with the power supply turned off.

Do not route the communication cable near to high voltage cables such as a power cable or high current electrical cable.

Be sure to connect terminal resistors to both ends of the DeviceNet™ main cable.

The drain wire should be connected to ground at one point only in the communication network.

Grounding should only be made at one point.

○DeviceNet™ Media Topology

A shielded twisted pair cable for DeviceNet™ should be used.

The maximum cable length depends on the communication speed and the cable type used.

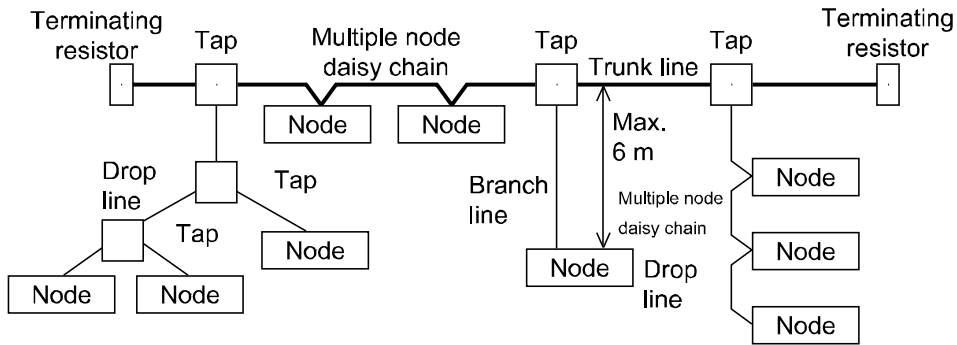

<Communication speed [kbps] and maximum bus cable length>

Communication speed	Max. cable length for network		Drop line length	Cumulative Drop
	Thick cable	Thin cable		
500 kbps	100 m	100 m	6 m or less	39 m max.
250 kbps	250 m	100 m		78 m max.
125 kbps	500 m	100 m		156 m max.

○Terminating resistors

DeviceNet™ requires a terminating resistor to be installed at each end of the trunk.

The resistor requirements are:

- 121 Ω
- 1% metal film
- 1/4 watt

Terminating resistors should not be installed at the end of a drop line, only at the two ends of trunk line.

○Power supply wiring (Power supply for solenoid valve)

MSTB2, 5/2-STF-5, 08 connectors manufactured by Phoenix Contact are attached to the SI unit for mounting on the cable.

The power supply connector for the solenoid valve is wired in the following way.

The connector screws should be tightened securely with a tightening torque of 0.5 to 0.6 Nm.

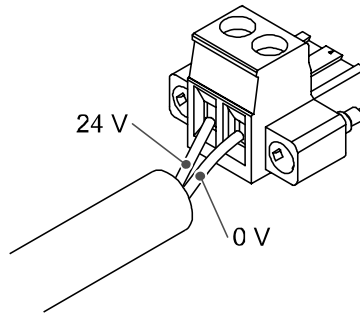

Power supply connector for solenoid valve

Terminal	Wire colour	Connection
24 V	-	For solenoid valve +24 V
0 V	-	For solenoid valve 0 V

Note

Wiring should be carried out with the power supply turned off.

Within the SI unit there are separate power supplies for the solenoid valves and DeviceNet™ communications.

Supply 24 VDC to each of them.

Power can be supplied from a single power supply or from separate power supplies.

A. With separate power supplies

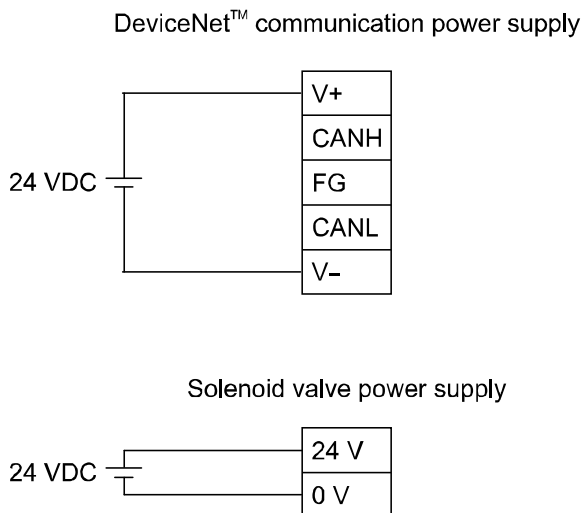

B. With one power supply

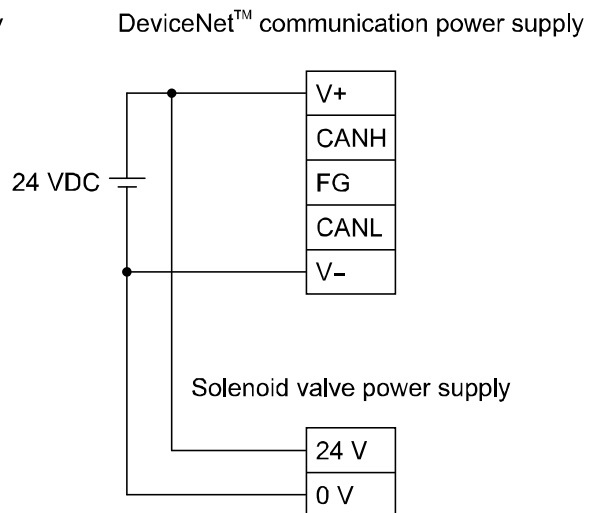

*: Pay attention not to exceed the tolerance range of power supply voltage.

LED indication and settings

o LED display

EX120-SDN1 (-X2/-X26/-X77)
 EX121-SDN1 (-X2/-X26/-X77)
 EX122-SDN1 (-X2/-X26/-X77)

EX124D-SDN1 (-X2/-X26/-X77)
 EX124U-SDN1 (-X2/-X26/-X77)

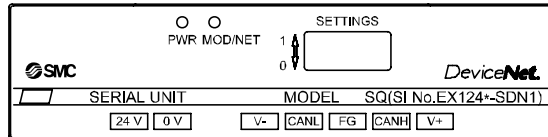
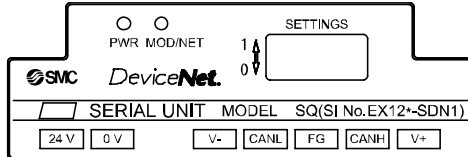

LED	Display	
PWR	Green LED is ON when power for communication is supplied.	
MOD/NET	LED is off	The unit is not on-line or the power supply for communication is off.
	Green flashing	Connection stand-by (on-line status)
	Green On	Connection established (on-line status)
	Red flashing	Connection time-out (recoverable communication error)
	Red On	MAC ID duplication error or BUS OFF error (serious communication error)

○Switch setting (EX12*-SDN1, EX12*-SDN1-X2)

Use the 8 way switch on the SI unit to set the node address (MAC_ID) and DeviceNet™ communication speed.

Note

1. Open the cover of the SI unit and use a flat blade screwdriver to set the switches.
2. Turn off the power supply while setting the switches.
3. Be sure to set the switches before use.

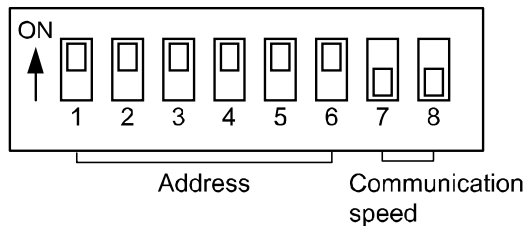

●Address setting (switch No. 1 to 6)

Set the DeviceNet™ node address with a binary code between 0 and 63. The default setting is all switches ON, so the MAC ID is set to 63.

0: OFF 1: ON

Switch No.	No.1	No.2	No.3	No.4	No.5	No.6
	1	2	4	8	16	32
0	0	0	0	0	0	0
1	1	0	0	0	0	0
2	0	1	0	0	0	0
:	:	:	:	:	:	:
62	0	1	1	1	1	1
63	1	1	1	1	1	1

●Communication speed setting (switches No. 7 to 8)

Set the DeviceNet™ communication speed with a binary code of 125 kbps or 250 kbps or 500 kbps. The default setting of this function is both switches “OFF”, so the default value is set to 125 kbps.

0: OFF 1: ON

Switch No.	No.7	No.8
125 kbps	0	0
250 kbps	1	0
500 kbps	0	1
-	1	1

○Settings via network (EX12*-SDN1, EX12*-SDN1-X2)

It is possible to set the output operation via the network, when a communication error is generated, in accordance with the procedure below.

●Output operation setting at the time of communication error

1) The instant attribute value below is set to 1 via the network

Class	Instance	Attribute	Description	Value
64h (SMC)	01h	68h (104)	Hold Clear (Timeout)	0: Clear setting valid (Default)
				1: Fault action valid

or

Class	Instance	attribute	Description	Value
0Fh (Parameter)	01h	01h	Hold Clear (Timeout)	0: Clear setting valid
				1: Fault action valid

2) Set the fault action and fault values via the network.

Fault setting method is the individual setting per output with DOP object.

Fault setting	Class	Instance	Attribute	Value
Fault action	09h (DOP)	n (Output number+1)	05h	0: Fault set value 1: Output held
Fault value			06h	0: CLEAR 1: SET

*: For details, refer to "Object mounting".

●Output condition setting when I/O connection is deleted

1) The instant attribute value below is set to 1 via the network.

Class	Instance	attribute	Description	Value
64h (SMC)	01h (01)	69h (105)	Hold Clear (Connection Delete)	0: Clear setting valid (Default)
				1: Fault action valid

2) Set the fault action and fault values via the network.

Fault setting method is the individual setting per output with DOP object.

Fault setting	Class	Instance	Attribute	Value
Fault action	09h (DOP)	n (Output number+1)	05h	0: Fault set value 1: Output held
Fault value			06h	0: CLEAR 1: SET

*: For details, refer to "Object mounting".

○Switch settings (EX12*-SDN1-X26/-X77)

Use the 10 way switch on the SI unit to set the node address (MAC_ID) and DeviceNet™ communication speed.

Note

1. Open the cover of the SI unit and use a flat blade screwdriver to set the switches.
2. Turn off the power supply while setting the switches.
3. Be sure to set the switches before use.

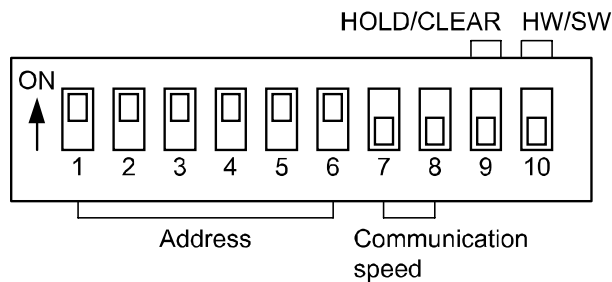

●**Address setting (switches No. 1 to 6)**

Set the DeviceNet™ node address with a binary code between 0 and 63. The default setting is all switches ON, so the MAC ID is set to 63. The MAC ID should be set in the range of 0 to 63.

0: OFF 1: ON

Switch No.	No.1	No.2	No.3	No.4	No.5	No.6
	1	2	4	8	16	32
MAC ID	0	0	0	0	0	0
1	1	0	0	0	0	0
2	0	1	0	0	0	0
:	:	:	:	:	:	:
62	0	1	1	1	1	1
63	1	1	1	1	1	1

●**Communication speed setting (switches No. 7 to 8)**

Set the DeviceNet™ communication speed with a binary code of 125 kbps or 250 kbps or 500 kbps. The default setting of this function is both switches “OFF”, so the default value is set to 125 kbps.

0: OFF 1: ON

Switch No.	No.7	No.8	
Communication speed	125 kbps	0	0
	250 kbps	1	0
	500 kbps	0	1
	-	1	1

●**HOLD/CLEAR setting (Switch No.9)**

Set the output condition when a communication error is generated. (All outputs will be set with the same conditions. *)

The default setting of this function is both switches “OFF”, so the default value is set to CLEAR.

0: OFF 1: ON

Switch No.		No.9	Function
HOLD/CLEAR	CLEAR	0	If a communication error occurs, the output will be cleared.
	HOLD	1	If a communication error occurs, the output will be retained.

*: It is possible to set the operation setting of each output via the network, when a communication error is generated.

●**HW/SW setting (switch No.10)**

Set the method of selecting the address, speed and output condition settings, which can be set either by switch setting or via the network.

The default setting of this function is both switches “OFF”, so the default value is set to HW.

0: OFF 1: ON

Switch No.		No.10	Function
HW/SW	HW	0	Address/communication speed is set using switches No. 1 to 8.
	SW	1	Address/communication speed is set via the network. * The function of the switches No.1 to 8 will become invalid.

*: Refer to "Network setting" for the setting method via the network.

○**Settings via the network (EX12*-SDN1-X26/-X77)**

It is possible to set the node address (MAC_ID), DeviceNet™ communication speed and output condition via the network, when a communication error is generated, in accordance with the procedure below.

●**Node address setting, Communication speed setting**

- 1) Turn on (SW mode) the switch No. 10 of the 10-digit switch mounted on the SI unit.
- 2) Change the instance attribute value via the network as indicated below.

Class	Instance	Attribute	Description	Value
03h (DeviceNet™)	01h (01)	01h (01)	MAC ID (Node address)	0 to 63
	01h (01)	02h (02)	Baud_rate (Communication speed)	0: 125 kbps 1: 250 kbps 2: 500 kbps

*: The address and communication speed set in SW mode will be kept even after the DeviceNet™ communication power supply to the SI unit is turned off.

When the power supply is applied in HW mode setting, the node address and communication speed set in SW mode is deleted and the set value on the switch is memorized.

•Output condition setting during I/O connection time-out

1) The instant attribute value below is set to 1 via the network.

Class	Instance	Attribute	Description	Value
64h (SMC)	01h	68h (104)	Hold Clear (Connection Delete)	0: Switch No.9 setting valid
				1: Fault action valid

or

Class	Instance	Attribute	Description	Value
0Fh (Parameter)	02h	01h	Hold Clear (Connection Delete)	0: Switch No.9 setting valid
				1: Fault action valid

2) Set the fault action and fault values via the network.

Fault setting method is the individual setting per output with DOP object.

Fault setting	Class	Instance	Attribute	Value
Fault action	09h (DOP)	n (Output number+1)	05h	0: Fault set value 1: Output held
Fault value			06h	0: CLEAR 1: SET

*: For details, refer to "Object mounting".

•Output condition setting when I/O connection is deleted

1) The instant attribute value is set to 1 via the network as indicated below.

Class	Instance	Attribute	Description	Value
64h (SMC)	01h (01)	69h (105)	Hold Clear (Connection Delete)	0: Switch No.9 setting valid
				1: Fault action valid

2) Set the fault action and fault values via the network.

Fault setting method is the individual setting per output with DOP object.

Fault setting	Class	Instance	Attribute	Value
Fault action	09h (DOP)	n (Output number+1)	05h	0: Fault set value 1: Output held
Fault value			06h	0: CLEAR 1: SET

*: For details, refer to "Object mounting".

o I/O memory map

The SI unit occupies the memory area of 16 output points (2 bytes).

The SI unit cannot be connected to an input device, but occupies memory areas of 16 input points (2 bytes) as a mirror function of output data. *

*: Mirror function: Output data received by the SI unit will be transmitted as input data exactly as it is.

EX12*-SDN1 and EX12*-SDN1-X2 have this device. (EX12*-SDN1-X26 and EX12*-SDN1-X77 do not occupy the input area.)

Output area mapping

offset (Word)	offset (Byte)	Output data			
		MSB 7	OUT1	LSB 0
QWn	QBn+0	OUT7	OUT1	OUT0
	QBn+1	OUT15	OUT9	OUT8

Input mapping (Mirror data of the output data, EX12*-SDN1/-X2)

offset (Word)	offset (Byte)	Input data			
		MSB 7	(OUT1)	LSB 0
IWn	IBn+0	(OUT7)	(OUT1)	(OUT0)
	IBn+1	(OUT15)	(OUT9)	(OUT8)

○Output number assignment

Combinations of the output data and the valve manifold

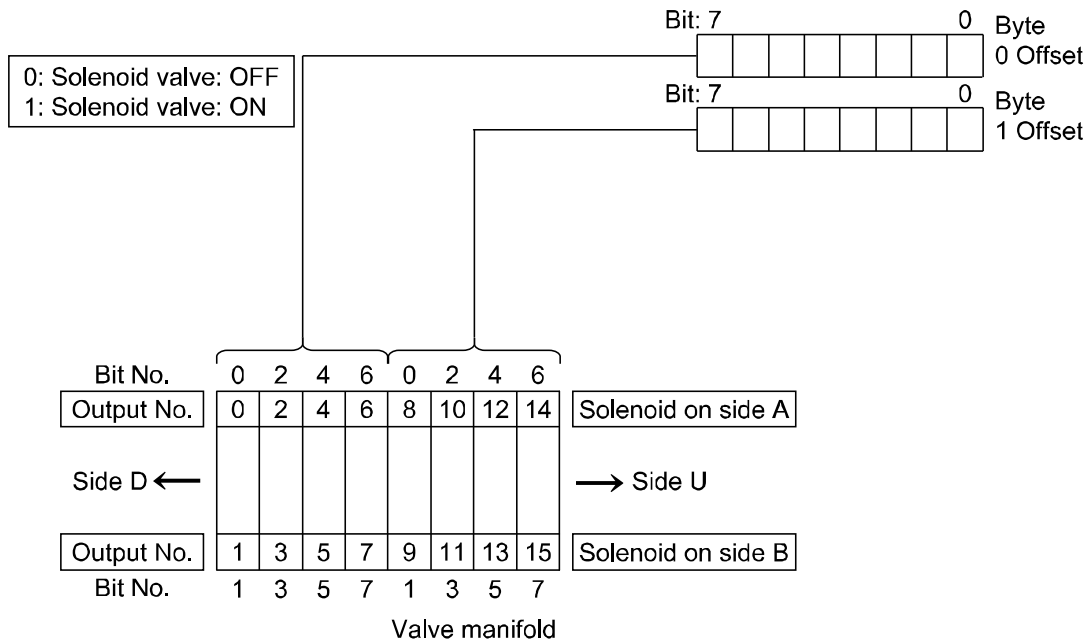

- *: Output No. starts from 0, and will be assigned to the valves in order from the SI unit mounted side.
- *: Standard wiring on the manifold is for double-solenoid valves and output number starts A side and B side in that order as shown in the figure a.
If you mount a single-solenoid valve on the standard wiring manifold, output number for B side valve is skipped.
- *: Custom wiring for mixed mounting single-solenoid valves and double-solenoid-valves can be specified with a Wiring Specification Sheet. Example wiring is shown in the figure b.
- *: Bit status "0" and "1" on a data corresponds solenoid valve status ON and OFF (0: OFF, 1: ON), and output number starts at zero from LSB (least significant bit).

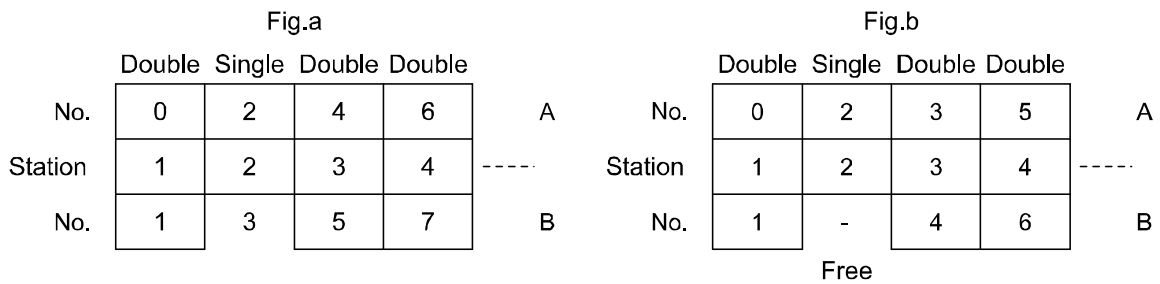

DeviceNet™ Objects

○ DeviceNet Objects

The SI unit supports the DeviceNet™ object classes below, with pneumatic valves as the device type.

*: Hexadecimal value is used for □□h indication.

Class code	Object class
01h	Identity
02h	Message Router
03h	DeviceNet™
04h	Assembly
05h	DeviceNet™ Connection
09h	Discrete Output Point
0Fh	Parameter
64h	SMC SI (SMC Specific)

1. Identity Object (Class ID: 01h)

1-1. Class attribute

ID	Access rule	Description	Value
-	-	-	-

1-2. Class common service

Service code	Service name
-	-

1-3. Instance attribute

ID	Access rule	Description	Value
1	Get	Vender ID	07h
2	Get	Device Type	EX12*-SDN1/-X2: 10h (16) EX12*-SDN1-X26/-X77: 1Bh (27)
3	Get	Product Code	EX12*-SDN1/-X2: 120h (288) EX12*-SDN1-X26/-X77: 4B2h (1202)
4	Get	Revision	Per unit
5	Get	Status	-
6	Get	Serial Number	Per unit
7	Get	Product Name	Valve manifold SIU

1-4. Instance common service

Service code	Description
05h	Reset
0Eh	Get_Attribute_Single

1-5. Specific service

None.

2. Message Router Object (Class ID: 02h)

2-1. Class attribute

ID	Access rule	Description	Value
-	-	-	-

2-2. Class common service

Service code	Description
-	-

2-3. Instance attribute

ID	Access rule	Description	Value
-	-	-	-

2-4. Instance common service

Service code	Description
-	-

2-5. Specific service

None.

3. DeviceNet™ Object (Class ID: 03h)

3-1. Class attribute

ID	Access rule	Description	Value
1	Get	revision	2

3-2. Class common service

Service code	Description
0Eh	Get_Attribute_Single

3-3. Instance attribute

ID	Access rule	Description	Value
1	Get/Set *1	MAC ID	0-63
2	Get/Set *1	Baud Rate	0-2
3	Get/Set	Bus Off Interrupt (BOI)	0-1
4	Get/Set	Bus Off Counter	0-255
5	Get	Allocation Information	-
6	Get	MAC ID Switch Changed	0-1
7	Get	Baud Rate Switch Changed	0-1
8	Get	MAC ID Switch Value	0-63
9	Get	Baud Rate Switch Value	0-2
10	Set	Quick Connect	0-1

*1: "Set" is available in SW mode.

3-4. Instance common service

Service code	Description
0Eh	Get_Attribute_Single
10h	Set_Attribute_Single

3-5. Specific service

Service code	Description
4Bh	Allocate_Master/Slave_Connection_set
4Ch	Release_Group_2_Identifier_Set

4. Assembly Object (Class ID: 04 h)

4-1. Class attribute

ID	Access rule	Description	Value
-	-	-	-

4-2. Class common service

Service code	Service name
-	-

4-3. Instance attribute

ID	Access rule	Description
3	Get/Set *1	Data

*1: If the instance type is input, the access rule will be Get.

4-4. Solenoid status assembly instance

(EX12*-SDN1/-X2 supports the following functions, but EX12*-SDN1-X26 and -X77 do not.)

ID	Type	Description	Byte
5	Input	16 Solenoid status Points	2

The data format is shown below. (Mirror data of the output data)

ID	Byte offset	Data							
		bit7				bit0			
5	IBn+0	(OUT7)	(OUT6)	(OUT5)	(OUT4)	(OUT3)	(OUT2)	(OUT1)	(OUT0)
	IBn+1	(OUT15)	(OUT14)	(OUT13)	(OUT12)	(OUT11)	(OUT10)	(OUT9)	(OUT8)

4-5. Solenoid output assembly instance

ID	Type	Description	Byte
35	Output	16 Solenoid output points	2

The data format is shown below.

ID	Byte offset	Data							
		bit7				bit0			
35	+0	OUT7	OUT6	OUT5	OUT4	OUT3	OUT2	OUT1	OUT0
	+1	OUT15	OUT14	OUT13	OUT12	OUT11	OUT10	OUT9	OUT8

4-6. Instance common service

Service code	Description
0Eh	Get_Attribute_Single
10h	Set_Attribute_Single

4-7. Specific service

None.

5. DeviceNet™ Connection Object (Class ID: 05h)

5-1. Class attribute

ID	Access rule	Description	Value
-	-	-	-

5-2. Class common service

Service code	Description
-	-

5-3. Instance attribute1 (Explicit message)

ID	Access rule	Description	Value
1	Get	State	-
2	Get	Instance_type	00h
3	Get	TransportClass_trigger	83h
4	Get	DeviceNet™_produced_connection_id	-
5	Get	DeviceNet™_consumed_connection_id	-
6	Get	DeviceNet™_initial_comm_characteristics	21h
7	Get	Produced_connection_size	FFFFh
8	Get	Consumed_connection_size	FFFFh
9	Get/Set	Expected_packet_rate	-
12	Get/Set	Watchdog_timeout_action	-
13	Get	Produced_connection_path_length	0
14	Get	Produced_connection_path	None
15	Get	Consumed_connection_path_length	0
16	Get	Consumed_connection_path	None
17	Get	Production_inhibit_time	0

5-4. Instance attribute2 (I/O: Poll message)

ID	Access rule	Description	Value
1	Get	State	-
2	Get	Instance_type	01h
3	Get	TransportClass_trigger	82h
4	Get	DeviceNet™_produced_connection_id	-
5	Get	DeviceNet™_consumed_connection_id	-
6	Get	DeviceNet™_initial_comm_characteristics	01h
7	Get	Produced_connection_size	02h: EX12*-SDN1/-X2 00h: EX12*-SDN1-X26/-X77
8	Get	Consumed_connection_size	02h
9	Get/Set	Expected_packet_rate	-
12	Get/Set	Watchdog_timeout_action	-
13	Get	Produced_connection_path_length	6: EX12*-SDN1/-X2 0: EX12*-SDN1-X26/-X77
14	Get	Produced_connection_path	20h, 04h, 24h, 05h, 30h, 03h: EX12*-SDN1/-X2 None: EX12*-SDN1-X26/-X77
15	Get	Consumed_connection_path_length	6
16	Get	Consumed_connection_path	20h 04h 24h 23h 30h 03h
17	Get	Production_inhibit_time	0

5-5. Instance common service

Service code	Description
0Eh	Get_Attribute_Single
10h	Set_Attribute_Single

6. Discrete Output Point Object (Class ID: 09h)

6-1. Class attribute

ID	Access rule	Description	Value
-	-	-	-

6-2. Class common service

Service code	Description
-	-

6-3. Instance attribute

ID	Access rule	Description	Value
3	Get/Set	Value	0: OFF 1: ON
4	Get	Status	0: Normal 1: Valve power supply failure
5	Get/Set *1	Fault Action	0: Fault value 1: Output held
6	Get/Set *1	Fault Value	0: CLEAR 1: SET
7	Get/Set *1	Idle Action	0: Idle value 1: Output held
8	Get/Set *1	Idle Value	0: CLEAR 1: SET

*1: Hold the data in EEPROM.

6-4. Instance common service

Service code	Description
0Eh	Get_Attribute_Single
10h	Set_Attribute_Single

6-5 Specific service

None.

7. Parameter Object (Class ID: 0Fh)

7-1. Class attribute

ID	Access rule	Description	Value
2	Get	Max. Instance	2
8	Get	Parameter Class Descriptor	1
9	Get	Configuration Assembly Instance	0

7-2. Class common service

Service code	Description
0Eh	Get_Attribute_Single

7-3. Instance attribute 1: Hold/Clear (Timeout)

ID	Access rule	Description	Value
1	Get	Parameter Value	0: Clear setting valid (EX12*-SDN1/-X2) Switch No.9 setting valid (EX12*-SDN1-X26/-X77) 1: Fault action valid
2	Get	Link Path Size	6
3	Get	Link Path	20h 64h 24h 01h 30h 68h
4	Get	Descriptor	20h
5	Get	Data Type	C1h
6	Get	Data Size	1

7-4. Instance attribute 2: HOLD/Clear (Delete)

ID	Access rule	Description	Value
1	Get	Parameter Value	0: Clear setting valid (EX12*-SDN1/-X2) Switch No.9 setting valid (EX12*-SDN1-X26/-X77) 1: Fault action valid
2	Get	Link Path Size	6
3	Get	Link Path	20h 64h 24h 01h 30h 69h
4	Get	Descriptor	20h
5	Get	Data Type	C1h
6	Get	Data Size	1

*1: This product does not have a function that monitors the valve power supply fuse.
The value is always 0.

7-5. Instance common service

Service code	Service name
0Eh	Get_Attribute_Single
10h	Set_Attribute_Single

7-6 Specific service

None.

8. SMC SI Object (Class ID: 64h)

8-1. Class attribute

ID	Access rule	Description	Value
-	-	-	-

8-2. Class common service

Service code	Service name
-	-

8-3. Instance attribute

ID	Access rule	Description	Value
104	Get	Hold/Clear (Timeout)	0: Clear setting valid (EX12*-SDN1/-X2) Switch No.9 setting valid (EX12*-SDN1-X26/-X77) 1: Fault action valid
105	Get	Hold/Clear (Delete)	0: Clear setting valid (EX12*-SDN1/-X2) Switch No.9 setting valid (EX12*-SDN1-X26/-X77) 1: Fault action valid

*: This product does not have a function that monitors the valve power supply fuse. The value is always 0.

8-4. Instance common service

Service code	Description
0Eh	Get_Attribute_Single
10h	Set_Attribute_Single

8-5. Specific service

None.

Troubleshooting and maintenance

Troubleshooting flowchart

When any malfunction is observed, perform the following troubleshooting.

→ Yes

...→ No

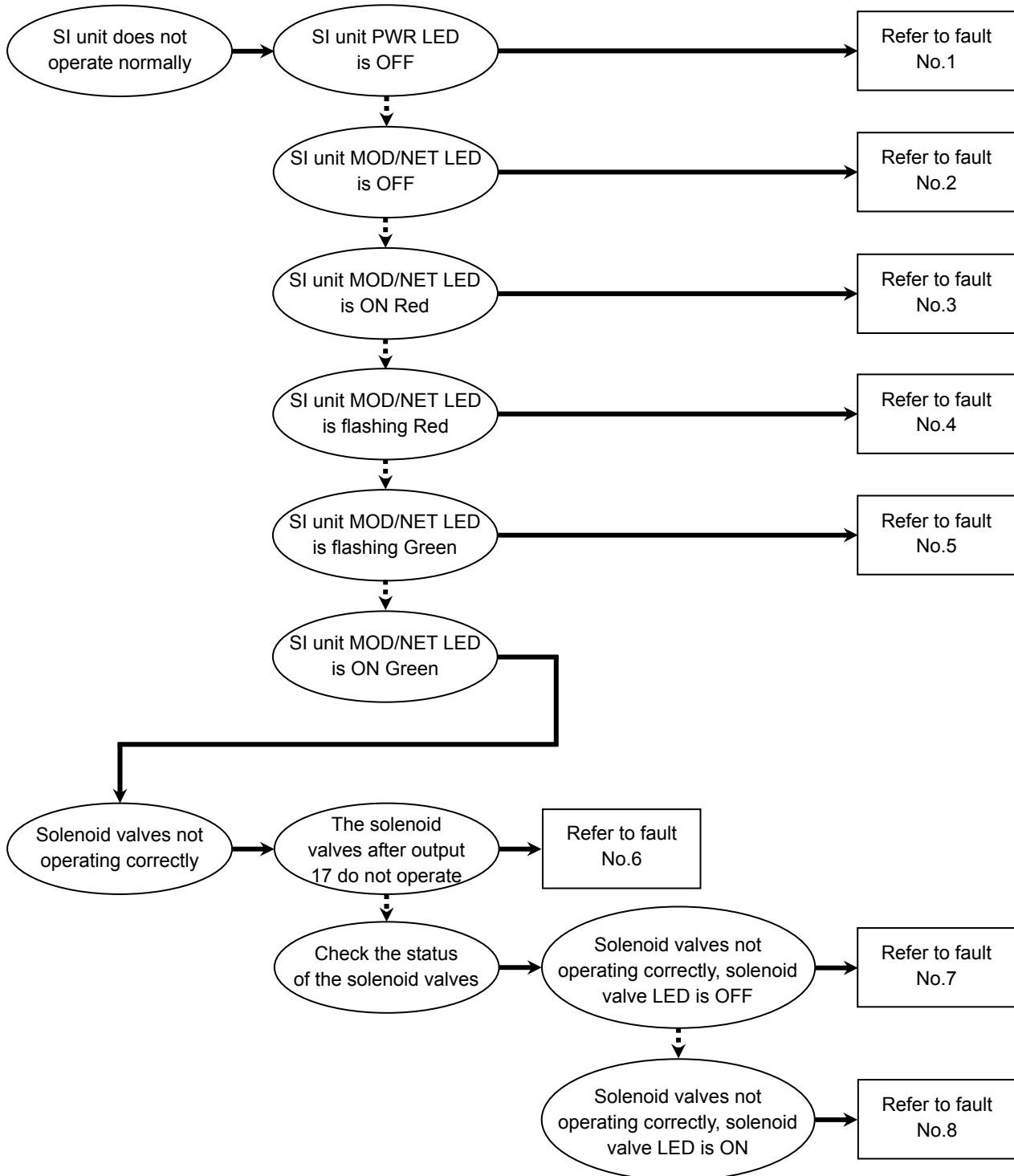

Troubleshooting table

Fault No.1

Problem	Possible cause	Investigation method	Countermeasures
SI unit PWR LED is OFF	Incorrect wiring of the power supply for DeviceNet™ communication	Check the power supply cable connections and check for broken wires.	Re-wire the power supply cable. (Replace the cable if it is damaged).
	Failure of the power supply for DeviceNet™ communication	Check the supply voltage of the DeviceNet™ power supply.	Correct the wiring of the power supply cable.
	Failure of the power supply for the DeviceNet™ master station	Check the supply voltage of the DeviceNet™ power supply.	Supply 11 to 25 VDC to the DeviceNet™ power supply.

Fault No.2

Problem	Possible cause	Investigation method	Countermeasures
SI unit MOD/NET LED is OFF	Incorrect wiring of the DeviceNet™ cable	Check the DeviceNet™ cable connections and check for broken wires.	Re-wire the DeviceNet™ cable. (Replace the cable if it is damaged).
	Failure of the power supply for the DeviceNet™ master station	Check the wiring of the power supply for the DeviceNet™ master station.	Correct the wiring of the DeviceNet™ cable.
	Failure of the power supply for the DeviceNet™ master station	Check the wiring of the power supply for the DeviceNet™ master station.	Check the power supply for the DeviceNet™ master station.

Fault No.3

Problem	Possible cause	Investigation method	Countermeasures
SI unit MOD/NET LED is ON Red	MAC ID duplication error	Check that there is no MAC ID duplication between the master and slave.	Correct the MAC ID settings.
	BUS OFF error	Check that the length of the communication cable is suitable for the communication speed, check for terminators at both ends, and check that the special cable for DeviceNet™ is used.	Correct the wiring and settings.
		Check that there is no equipment or high voltage cables which generates noise around the communication and power supply cables.	Separate the communication and power supply cables away from noise sources.
		Check the DeviceNet™ cable connections and check for broken wires. Confirm that repeated bending stresses or pulling forces are not applied to the cable which may cause broken wire.	Correct the connection of the DeviceNet™ cable.
	Confirm that the SI unit communication speed setting and the communication speed settings of the master and slave are the same.	Correct the communication speed settings.	
Failure of the communication device	-	Replace the SI unit.	

Fault No.4

Problem	Possible cause	Investigation method	Countermeasures
SI unit MOD/NET LED flashes Red	I/O connection timeout	Check that the length of the communication cable is suitable for the communication speed, check for terminators at both ends, and check that the special cable for DeviceNet™ is used.	Correct the wiring and settings.
		Check that there is no equipment or high voltage cables which generates noise around the communication and power supply cables.	Separate the communication and power supply cables away from noise sources.
		Check the DeviceNet™ cable connections and check for broken wires. Confirm that repeated bending stresses or pulling forces are not applied to the cable which may cause broken wire.	Correct the connection of the DeviceNet™ cable.
		Confirm that power is supplied to the master station.	Supply power to the master station correctly.

Fault No. 5

Problem	Possible cause	Investigation method	Countermeasures
SI unit MOD/NET LED flashes Green	Incorrect wiring of the power supply for DeviceNet™ communication	Check the DeviceNet™ cable connections and check for broken wires.	Re-wire the DeviceNet™ cable. (Replace the cable if it is damaged).
			Rectify the wiring of the DeviceNet™ cable.
	I/O connection stand-by (off-line status)	If the network is using a scan list, check that the slave is registered correctly into the scan list.	Correct the setting of the scan list.

Fault No. 6

Problem	Possible cause	Investigation method	Countermeasures
The solenoid valves after output 17 do not operate	The total number of solenoid valve outputs connected has exceeded the max. allowed	Check that the total number of outputs connected to the SI unit is 16 or less.	Make corrections so that the total number of outputs is 16 or less. Note when single solenoid valves are mounted onto a double wiring specified manifold.

Fault No. 7

Problem	Possible cause	Investigation method	Countermeasures
Solenoid valves do not operate correctly, solenoid valve LED is OFF	Poor connection between SI unit and valve manifold	Check if there are any loose screws making the connection between the SI unit and the Valve manifold.	Tighten the screws while holding the SI unit and the solenoid valve manifold so that there is no gap between them. Tighten the screws to the specified tightening torque.
	Polarity of the solenoid valve and the SI unit output are not compatible	Check that the solenoid valve polarity specification and output polarity of the SI unit are compatible.	Use a solenoid valve polarity compatible with the output polarity of the SI unit.
	Solenoid valve failure	Refer to the troubleshooting of the solenoid valve.	Refer to the troubleshooting of the solenoid valve.

Fault No. 8

Problem	Possible cause	Investigation method	Countermeasures
Solenoid valves do not operate correctly, solenoid valve LED is ON.	Solenoid valve failure	Refer to the troubleshooting of the solenoid valve.	Refer to the troubleshooting of the solenoid valve.

<Precautions for replacement of SI unit>

1. Be sure to turn the power OFF before replacing the SI unit.
Otherwise injury or SI unit malfunction can result.
2. Check the wiring before supplying power.
Otherwise damage to the SI unit can result in some wiring conditions, causing breakdown or malfunction.
3. The screws should be tightened to the specified torque.
4. Check the seal is not caught or left unmounted.
Otherwise, the enclosure conditions will not be satisfied (for EX124 Series).

○How to replace the EX120 Series SI unit

●Removal

1. Lift the clip at the bottom of the SI unit with a flat blade screw driver.
By lifting the clip, the hook will be removed from the manifold, and this releases the SI unit.

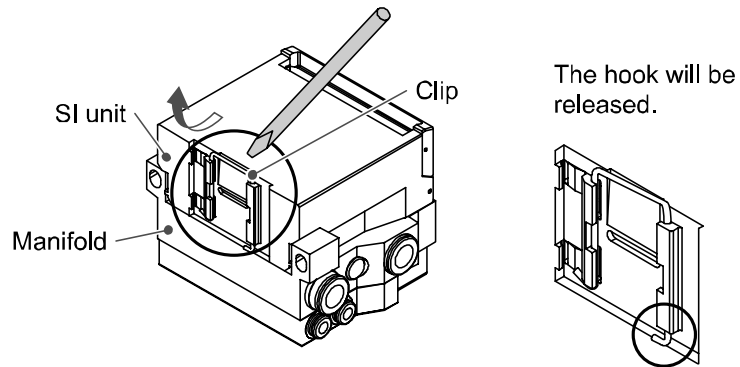

2. Slide the SI unit upwards with the clip pulled.

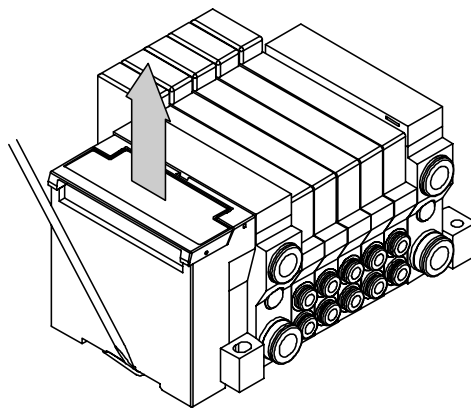

3. This releases the lock. Pull the SI unit slowly and remove from the manifold.

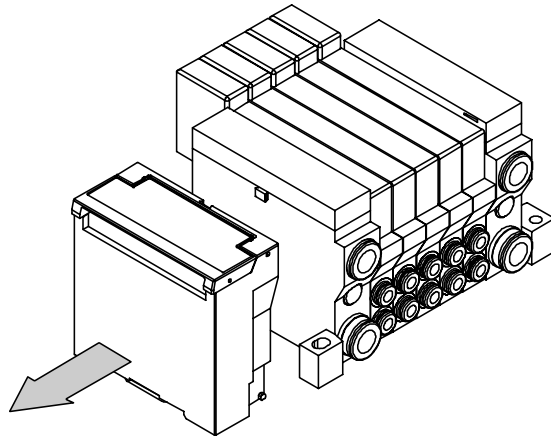

•Mounting

1. Align the raised part on the manifold side at the bottom of the SI unit with the groove of the manifold, and press it in evenly.

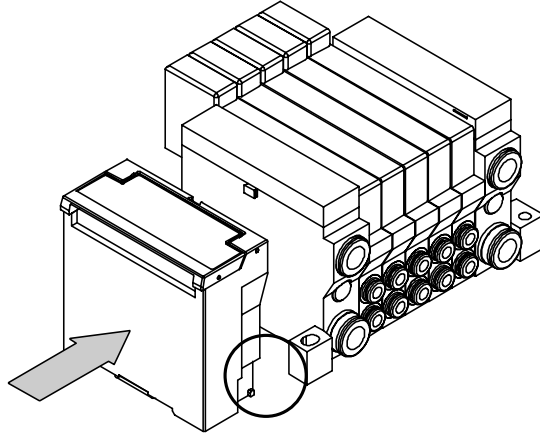

2. Confirm that the SI unit and manifold are securely locked together, and slide the SI unit downwards.

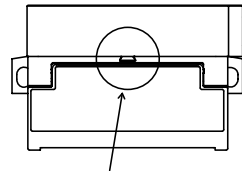
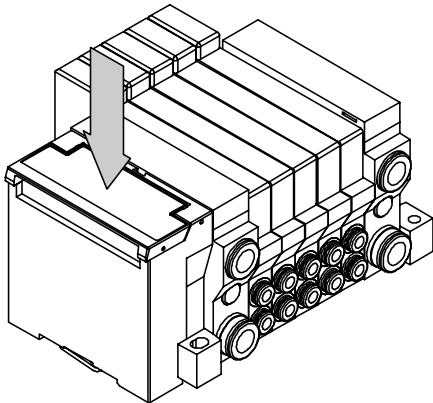

The raised part should fit into the groove in the manifold.

○How to replace the EX121/122 Series SI unit

●Removal

1. Loosen the mounting bracket screw.

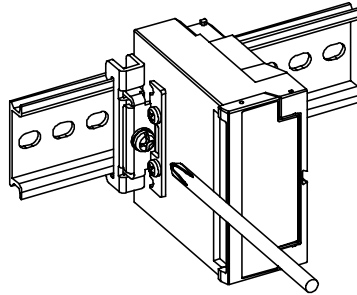

2. Remove the SI unit by unhooking claw 2 then claw 1.

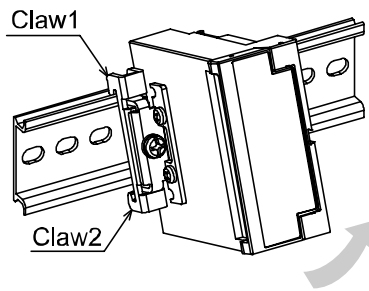

●Mounting

1. Hook claw 1 to the upper side of the DIN rail and claw 2 to the lower side.

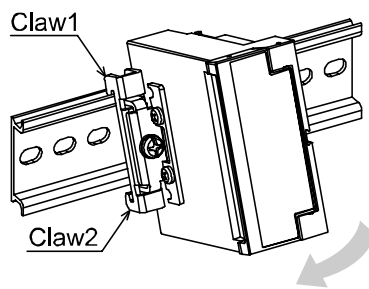

2. Tighten the mounting bracket screw, and fix the SI unit to the DIN rail. (Tightening torque: 0.6 Nm)

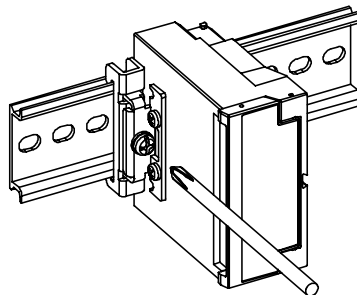

○How to replace the EX124 Series SI unit

●**Removal**

1. Remove the cover from the SI unit, by removing the screws (4xM4) which hold the cover.

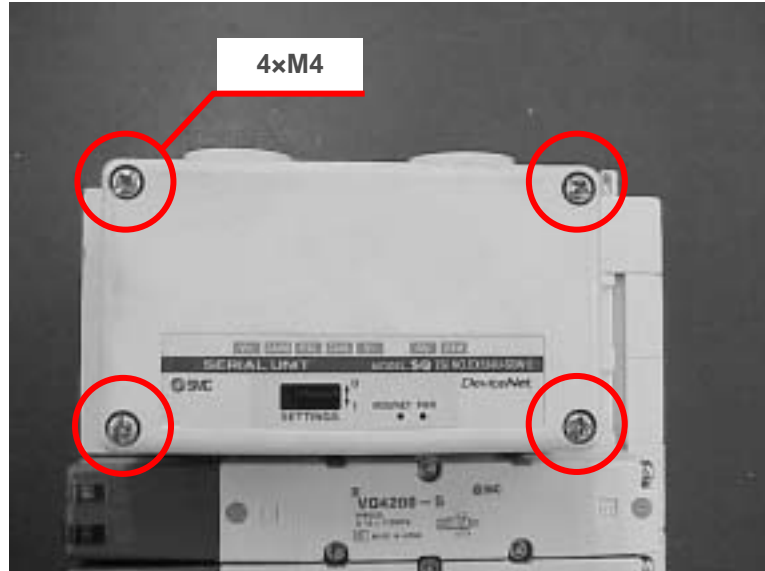

2. Disconnect the wiring from the SI unit, and remove the SI unit from the manifold.
Disconnect the wiring to the SI unit.
(Communication connector and power supply connector)
Remove the screws (4xM4) which secure the SI unit to the manifold.

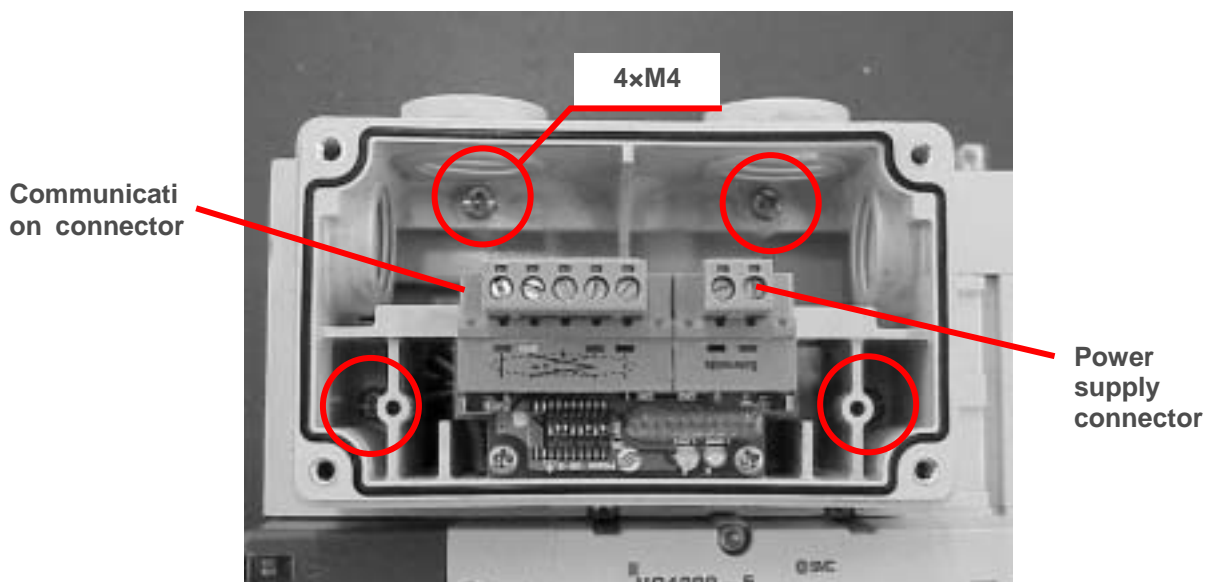

3. Remove the manifold wiring from the SI unit.

Pull out the cable with connector (manifold wiring) from the manifold while holding the board of the SI unit.

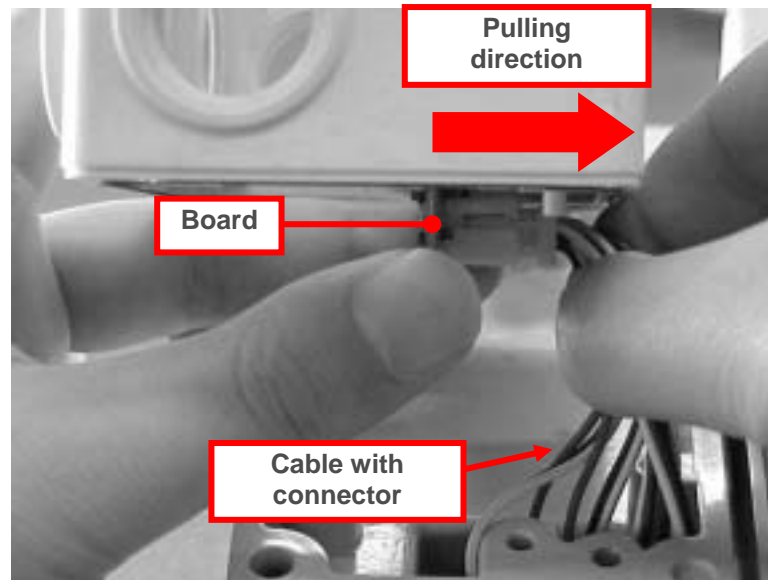

•**Mounting**

1. Connect the manifold wiring to the SI unit. (Follow the procedure of step 3 in reverse.)
 - Ensure the cable (manifold wiring) does not get caught between the SI unit and the manifold. Otherwise damage to the unit can result due to cable breakage, causing breakdown or malfunction.
 - Tighten the screws diagonally so that the SI unit is securely fitted. (Tightening torque: 0.6 Nm)
2. Mount the SI unit to the manifold, then mount the communication connector and power supply connector.
3. Mount the cover to the SI unit after setting the switches.

Tighten the screws diagonally so that the cover unit is securely fitted. (Tightening torque: 0.6 Nm)

Specifications

■ Specifications

General specification

Item	Specifications
Ambient temperature	0 to +55 °C (when 8 valves are ON at the same time) 0 to +50 °C (when 16 valves are ON at the same time)
Ambient humidity	35 to 85%RH (No condensate)
Ambient temperature for storage	-20 to +60 °C
Withstand voltage	1000 VAC applied for 1 minute
Insulation resistance	500 VDC, 2 MΩ or more
Operating atmosphere	No corrosive gas
Pollution degree	Pollution degree 3 *
Enclosure	EX120/121/122-SDN1 (-X2/-X26/-X77): IP20 EX124U/D-SDN1 (-X2/-X26/-X77): IP65
Standard	CE marking, RoHS
Weight	EX120-SDN1 (-X2/-X26/-X77): 110 g or less EX121-SDN1 (-X2/-X26/-X77): 140 g or less EX122-SDN1 (-X2/-X26/-X77): 130 g or less EX124U/D-SDN1 (-X2/-X26/-X77): 240 g or less

*: EX120/121/122-SDN1(-X2/-X26/-X77) are IP20 rated.

When operating this product in a pollution degree 3 environment, mount it onto an IP54 rate or higher controller board etc.

Electric specifications

Item	Specifications	
Power supply voltage range and current consumption	Power supply for DeviceNet™ communication	11 to 25 VDC 0.1 A or less
	Solenoid valve power supply	24 VDC+10%/-5% 1.5 A or less, according to the solenoid valve station specification
Solenoid valve specification	Output type (Valve common polarity)	EX12-SDN1/-X26: NPN (Positive common) EX12-SDN1-X2/-X77: PNP (Negative common)
	Number of outputs	16 outputs
	Connected load	Solenoid valve with surge voltage suppressor of 24 VDC and 1.5 W or less (manufactured by SMC)
	Output setting at the time of communication error	EX12*-SDN1/-X2: CLEAR EX12*-SDN1-X26/-X77: HOLD/CLEAR (Switch setting)
	Insulation type	Photo-coupler insulation type
	Residual voltage	0.4 VDC or less

Communication specification

Item	Specifications
Protocol	DeviceNet™ Volume1 (Edition 2.1) Volume3 (Edition 1.0)
Slave type	Group2 Only Server
Device type	EX12*-SDN1/-X2: 16 EX12*-SDN1-X26/-X77: 27
Product code	EX12*-SDN1/-X2: 288 EX12*-SDN1-X26/-X77: 1202
Vender ID	7h (SMC Corp.)
Applicable message	Duplicate MAC ID Check Message Unconnected Explicit Message Explicit Message Poll I/O Message (Predefined M/S connection set)
Node address setting range	0 to 63
Communication speed	125 kbps/250 kbps/500 kbps
Setting file: EDS file (Please download from SMC website)	EX12*-SDN1/-X2 : ex12#-sdn1_22_v□.eds EX12*-SDN1-X26/-X77 : ex12#-sdn1_02_v□.eds
Occupied area (Number inputs/Outputs)	EX12*-SDN1/-X2: 16/16 EX12*-SDN1-X26/-X77: 0/16

Compatible valve series

EX120-SDN1(-X2/-X26/-X77)	SV1000, SV2000, SV3000, SV4000 VQ1000, VQ2000 SY3000, SY5000 (Connector connecting manifold)
EX121-SDN1(-X2/-X26/-X77)	SY3000, SY5000
EX122-SDN1(-X2/-X26/-X77)	SY3000, SY5000
EX124U/D-SDN1(-X2/-X26/-X77)	VQ2000, VQ4000, VQ5000

■Dimensions

○EX120-SDN1(-X2/-X26/-X77)

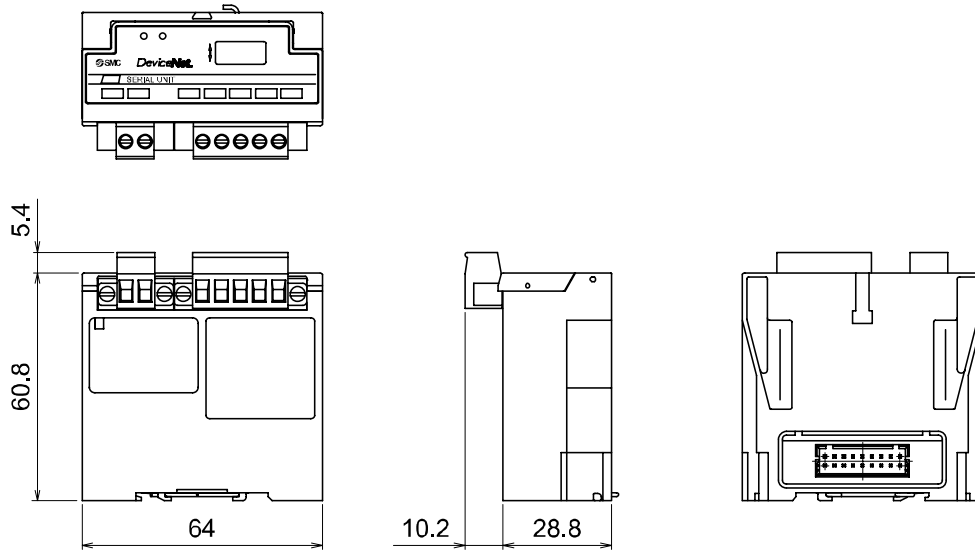

○EX121-SDN1(-X2/-X26/-X77)

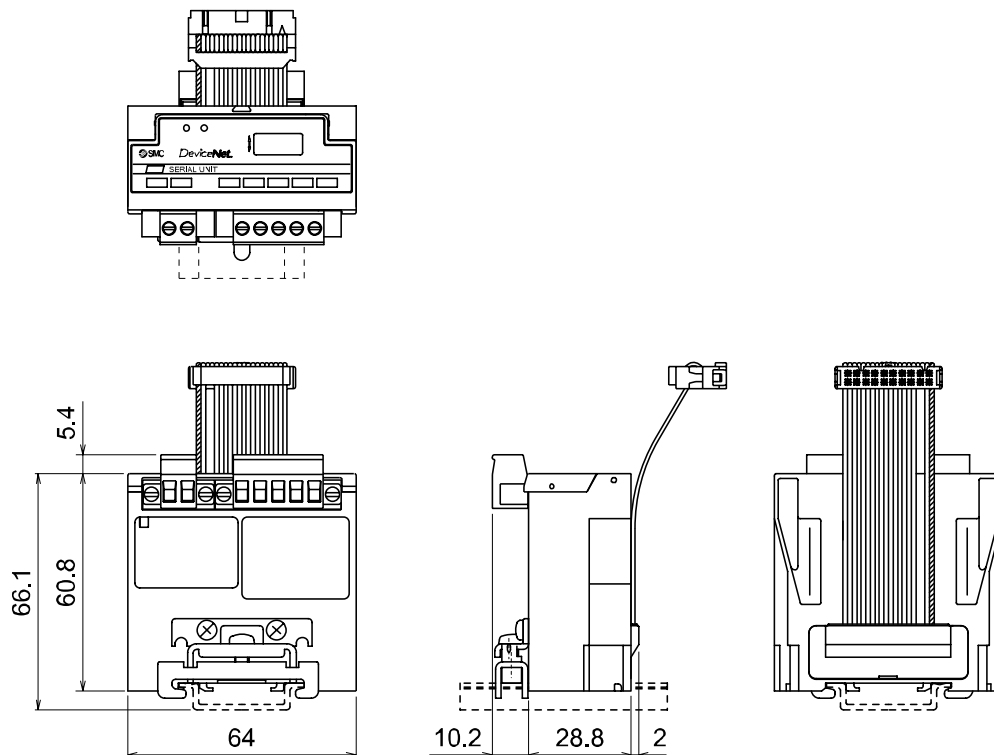

○EX122-SDN1(-X2/-X26/-X77)

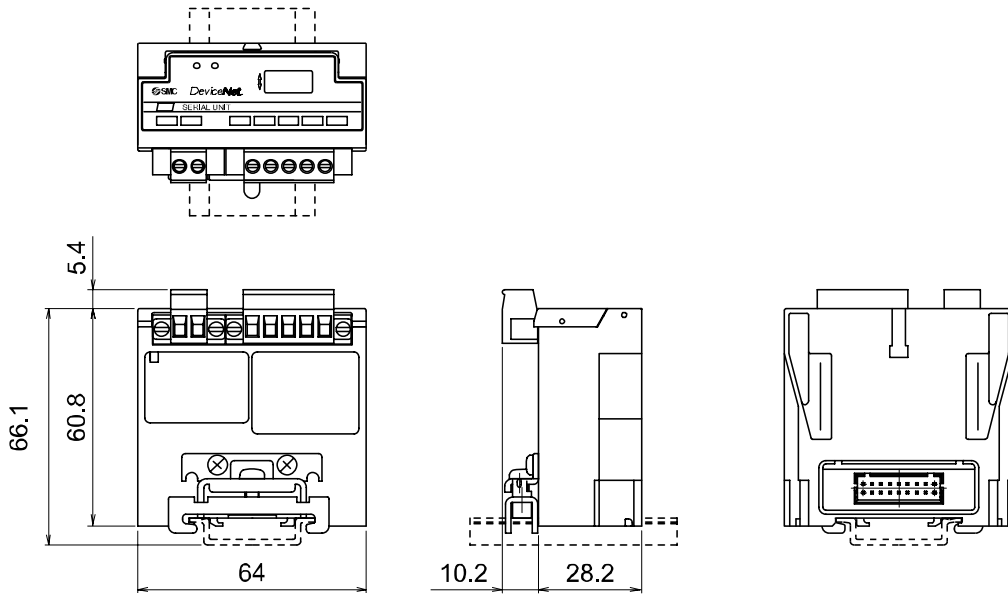

○EX124D-SDN1(-X2/-X26/-X77)

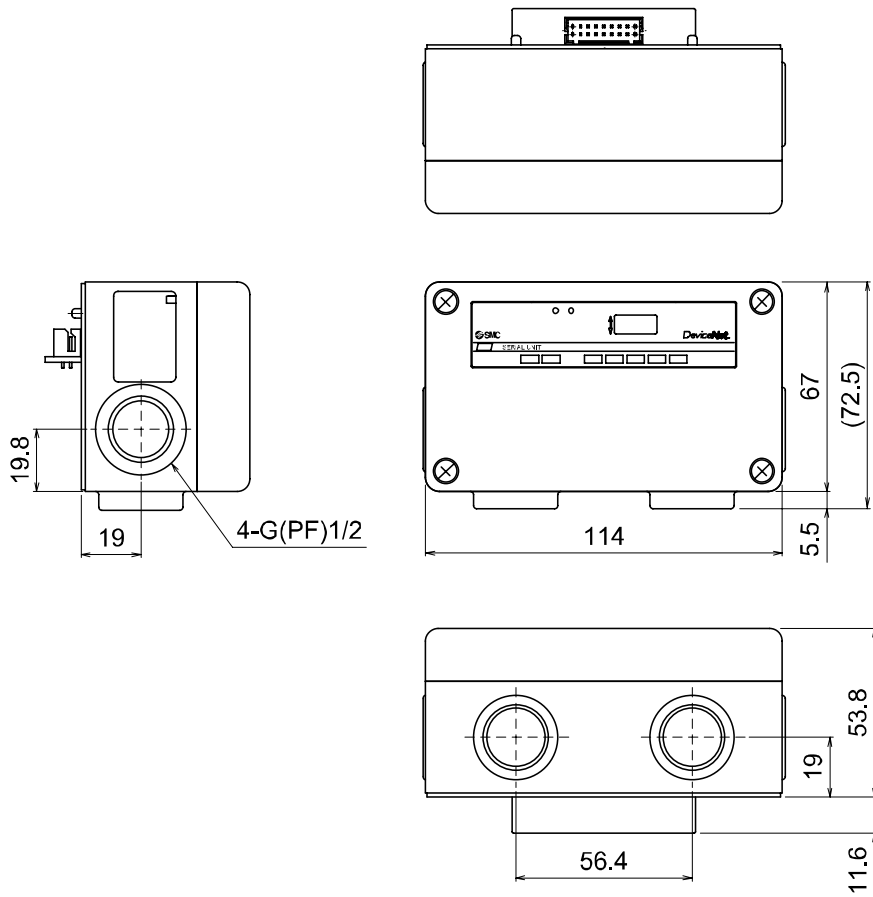

○EX124U-SDN1(-X2/-X26/-X77)

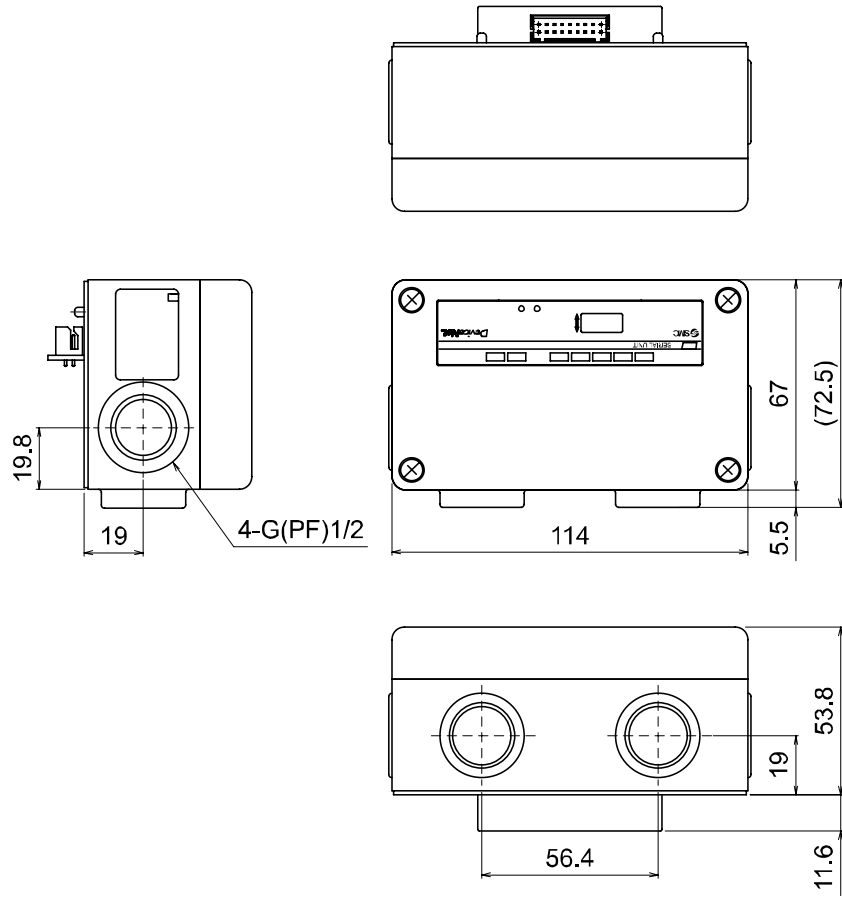

■ Accessary

○ Waterproof cap

Use for unused conduit port (G1/2) when using EX124 Series.

Part No: AXT100-B04A

Revision history
A: All revised contents
B: Revision

SMC Corporation

Akihabara UDX 15F,
4-14-1, Sotokanda, Chiyoda-ku, Tokyo 101-0021, JAPAN
Phone: +81 3-5207-8249 Fax: +81 3-5298-5362
URL <http://www.smcworld.com>

Note: Specifications are subject to change without prior notice and any obligation on the part of the manufacturer.

DeviceNet™ is a trademark of ODVA.

© 2011 SMC Corporation All Rights Reserved

