



# Operation Manual

PRODUCT NAME

Fieldbus system  
(CC-Link compliant)

MODEL / Series / Product Number

*EX510-GMJ1 Series*

**SMC Corporation**

## Table of Contents

Safety Instructions	3
Model Indication and How to Order	8
Summary of Product Parts	9
Definition and terminology	10
Common Specifications	12
<b>EX510 GW Unit</b>	
Summary of Product Parts	13
Mounting and Installation	14
Installation	14
Wiring	15
Setting	19
Specifications	25
Specifications	25
Dimensions	26
<b>SI Unit</b>	
Summary of Product Parts	27
Mounting and Installation	29
Installation	29
Wiring	30
Setting	34
Specifications	34
Specifications	34
Dimensions	35
<b>Output Unit</b>	
Summary of Product Parts	36
Mounting and Installation	37
Installation	37
Wiring	38
Specifications	41
Specifications	41
Dimensions	41



## ***Input Unit***

Summary of Product Parts	42
Mounting and Installation	43
Installation	43
Wiring	45
Specifications	48
Specifications	48
Dimensions	48
Maintenance	49
Troubleshooting	50
Option	55

## Safety Instructions

These safety instructions are intended to prevent hazardous situations and/or equipment damage. These instructions indicate the level of potential hazard with the labels of "Caution", "Warning" or "Danger". They are all important notes for safety and must be followed in addition to International standards (ISO/IEC) \*1) and other safety regulations.

- \*1) ISO 4414: Pneumatic fluid power -- General rules relating to systems.
- ISO 4413: Hydraulic fluid power -- General rules relating to systems.
- IEC 60204-1: Safety of machinery -- Electrical equipment of machines. (Part 1: General requirements)
- ISO 10218-1992: Manipulating industrial robots -Safety.
- etc.

- |  |  |
|--|--|
|  <b>Caution</b> : | CAUTION indicates a hazard with a low level of risk which, if not avoided, could result in minor or moderate injury.   |
|  <b>Warning</b> : | WARNING indicates a hazard with a medium level of risk which, if not avoided, could result in death or serious injury. |
|  <b>Danger</b> :  | DANGER indicates a hazard with a high level of risk which, if not avoided, will result in death or serious injury.     |

### **Warning**

**1. The compatibility of the product is the responsibility of the person who designs the equipment or decides its specifications.**

Since the product specified here is used under various operating conditions, its compatibility with specific equipment must be decided by the person who designs the equipment or decides its specifications based on necessary analysis and test results. The expected performance and safety assurance of the equipment will be the responsibility of the person who has determined its compatibility with the product. This person should also continuously review all specifications of the product referring to its latest catalogue information, with a view to giving due consideration to any possibility of equipment failure when configuring the equipment.

**2. Only personnel with appropriate training should operate machinery and equipment.**

The product specified here may become unsafe if handled incorrectly. The assembly, operation and maintenance of machines or equipment including our products must be performed by an operator who is appropriately trained and experienced.

**3. Do not service or attempt to remove product and machinery/equipment until safety is confirmed.**

1. The inspection and maintenance of machinery/equipment should only be performed after measures to prevent falling or runaway of the driven objects have been confirmed.
2. When the product is to be removed, confirm that the safety measures as mentioned above are implemented and the power from any appropriate source is cut, and read and understand the specific product precautions of all relevant products carefully.
3. Before machinery/equipment is restarted, take measures to prevent unexpected operation and malfunction.

**4. Contact SMC beforehand and take special consideration of safety measures if the product is to be used in any of the following conditions.**

1. Conditions and environments outside of the given specifications, or use outdoors or in a place exposed to direct sunlight.
2. Installation on equipment in conjunction with atomic energy, railways, air navigation, space, shipping, vehicles, military, medical treatment, combustion and recreation, or equipment in contact with food and beverages, emergency stop circuits, clutch and brake circuits in press applications, safety equipment or other applications unsuitable for the standard specifications described in the product catalogue.
3. An application which could have negative effects on people, property, or animals requiring special safety analysis.
4. Use in an interlock circuit, which requires the provision of double interlock for possible failure by using a mechanical protective function, and periodical checks to confirm proper operation.

## Caution

### **The product is provided for use in manufacturing industries.**

The product herein described is basically provided for peaceful use in manufacturing industries.

If considering using the product in other industries, consult SMC beforehand and exchange specifications or a contract if necessary.

If anything is unclear, contact your nearest sales branch.

## **Limited warranty and Disclaimer/Compliance Requirements**

The product used is subject to the following "Limited warranty and Disclaimer" and "Compliance Requirements".

Read and accept them before using the product.

### **Limited warranty and Disclaimer**

1. The warranty period of the product is 1 year in service or 1.5 years after the product is delivered. \*2)  
Also, the product may have specified durability, running distance or replacement parts. Please consult your nearest sales branch.
2. For any failure or damage reported within the warranty period which is clearly our responsibility, a replacement product or necessary parts will be provided.  
This limited warranty applies only to our product independently, and not to any other damage incurred due to the failure of the product.
3. Prior to using SMC products, please read and understand the warranty terms and disclaimers noted in the specified catalogue for the particular products.

\*2) Vacuum pads are excluded from this 1 year warranty.

A vacuum pad is a consumable part, so it is warranted for a year after it is delivered.

Also, even within the warranty period, the wear of a product due to the use of the vacuum pad or failure due to the deterioration of rubber material are not covered by the limited warranty.

### **Compliance Requirements**

1. The use of SMC products with production equipment for the manufacture of weapons of mass destruction (WMD) or any other weapon is strictly prohibited.
2. The exports of SMC products or technology from one country to another are governed by the relevant security laws and regulation of the countries involved in the transaction. Prior to the shipment of a SMC product to another country, assure that all local rules governing that export are known and followed.

## Operator

- ◆ This operation manual is intended for those who have knowledge of machinery using pneumatic equipment, and have sufficient knowledge of assembly, operation and maintenance of such equipment. Only those persons are allowed to perform assembly, operation and maintenance.
- ◆ Read and understand this operation manual carefully before assembling, operating or providing maintenance to the product.

### ■ Safety Instructions

#### **Warning**

- Do not disassemble, modify (including changing the printed circuit board) or repair.  
An injury or failure can result.
- Do not operate the product outside of the specifications.  
Do not use for flammable or harmful fluids.  
Fire, malfunction, or damage to the product can result.  
Verify the specifications before use.
- Do not operate in an atmosphere containing flammable or explosive gases.  
Fire or an explosion can result.  
This product is not designed to be explosion proof.
- If using the product in an interlocking circuit:
  - Provide a double interlocking system, for example a mechanical system.
  - Check the product regularly for proper operation.Otherwise malfunction can result, causing an accident.
- The following instructions must be followed during maintenance:
  - Turn off the power supply.
  - Stop the air supply, exhaust the residual pressure and verify that the air is released before performing maintenance.Otherwise an injury can result.

#### **Caution**

- After maintenance is complete, perform appropriate functional inspections.  
Stop operation if the equipment does not function properly.  
Safety cannot be assured in the case of unexpected malfunction.
- Provide grounding to assure the safety and noise resistance of the GW unit.  
Individual grounding should be provided close to the product with a short cable.

## ■NOTE

○Follow the instructions given below when designing, selecting and handling the product.

●The instructions on design and selection (installation, wiring, environment, adjustment, operation, maintenance, etc.) described below must also be followed.

\*Product specifications

●When conformity to UL is necessary the SI unit must be used with a UL1310 Class2 power supply.

●Use the specified voltage.

Otherwise failure or malfunction can result.

●Reserve a space for maintenance.

Allow sufficient space for maintenance when designing the system.

●Do not remove any nameplates or labels.

This can lead to incorrect maintenance, or misreading of the operation manual, which could cause damage or malfunction to the product.

●It may also result in non-conformity to safety standards.

●Product handling

\*Installation

●Do not drop, hit or apply excessive shock to the fieldbus system.

Otherwise damage to the product can result, causing malfunction.

●Tighten to the specified tightening torque.

If the tightening torque is exceeded the mounting screws may be broken.

●Never mount a product in a location that will be used as a foothold.

The product may be damaged if excessive force is applied by stepping or climbing onto it.

\*Wiring

●Avoid repeatedly bending or stretching the cables, or placing heavy load on them.

Repetitive bending stress or tensile stress can cause breakage of the cable.

●Wire correctly.

Incorrect wiring can break the product.

●Do not perform wiring while the power is on.

Otherwise damage to the fieldbus system and/or I/O device can result, causing malfunction.

●Do not route wires and cables together with power or high voltage cables.

Otherwise the fieldbus system and/or I/O device can malfunction due to interference of noise and surge voltage from power and high voltage cables to the signal line.

Route the wires (piping) of the fieldbus system and/or I/O device separately from power or high voltage cables.

●Confirm proper insulation of wiring.

Poor insulation (interference from another circuit, poor insulation between terminals, etc.) can lead to excess voltage or current being applied to the product, causing damage.

●Take appropriate measures against noise, such as using a noise filter, when the fieldbus system is incorporated into equipment.

Otherwise noise can cause malfunction.

●Separate the power line for output devices from the power line for input devices and controlling GW.

Otherwise noise or induced surge voltage can cause malfunction.

#### \*Environment

- Do not use the product in area that is exposed to corrosive gases, chemicals, sea water, water or steam.  
Otherwise failure or malfunction can result.
- Do not use in an area where surges are generated.  
If there is equipment which generates a large amount of surge (solenoid type lifter, high frequency induction furnace, motor, etc.) close to the fieldbus system, this may cause deterioration or breakage of the internal circuit of the fieldbus system. Avoid sources of surge generation and crossed lines.
- When a surge-generating load such as a relay or solenoid is driven directly, use an fieldbus system with a built-in surge absorbing element.  
Direct drive of a load generating surge voltage can damage the fieldbus system.
- The product is CE marked, but not immune to lightning strikes. Take measures against lightning strikes in the system.
- Prevent foreign matter such as remnant of wires from entering the fieldbus system to avoid failure and malfunction.
- Mount the product in a place that is not exposed to vibration or impact.  
Otherwise failure or malfunction can result.
- Do not use the product in an environment that is exposed to temperature cycle.  
Heat cycles other than ordinary changes in temperature can adversely affect the inside of the product.
- Do not expose the product to direct sunlight.  
If using in a location directly exposed to sunlight, shade the product from the sunlight.  
Otherwise failure or malfunction can result.
- Keep within the specified ambient temperature range.  
Otherwise malfunction can result.
- Do not operate close to a heat source, or in a location exposed to radiant heat.  
Otherwise malfunction can result.

#### \*Adjustment and Operation

- Set the switches by using a sharp-pointed screwdriver etc.  
It may damage set switches.
- Perform settings suitable for the operating conditions.  
Incorrect setting can cause operation failure.  
For details of each setting, refer to page 20 to 24 of this manual
- Please refer to the PLC manufacturer's manual etc. for details of programming and addresses.  
For the PLC protocol and programming refer to the relevant manufacturer's documentation.

#### \*Maintenance

- Turn off the power supply, stop the supplied air, exhaust the residual pressure and verify the release of air before performing maintenance.  
There is a risk of unexpected malfunction.
- Perform regular maintenance and inspections.  
There is a risk of unexpected malfunction.
- After maintenance is complete, perform appropriate functional inspections.  
Stop operation if the equipment does not function properly.  
Otherwise safety is not assured due to an unexpected malfunction or incorrect operation.
- Do not use solvents such as benzene, thinner etc. to clean the each unit.  
They could damage the surface of the body and erase the markings on the body.  
Use a soft cloth to remove stains.  
For heavy stains, use a cloth soaked with diluted neutral detergent and fully squeezed, then wipe up the stains again with a dry cloth.

# Model Indication and How to Order

- GW unit: CC-Link compatible

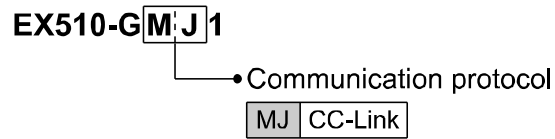

- Input unit

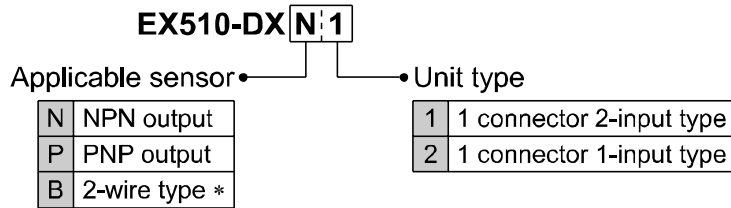

\*: B (2-wire type) is available with 1 connector, 2-input type only.

- SI unit

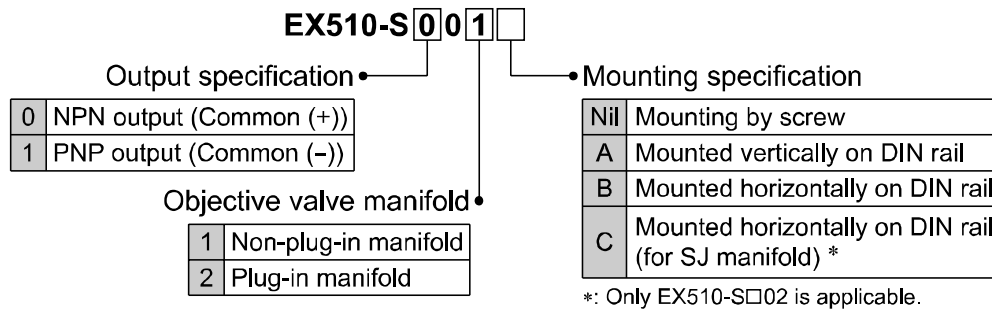

\*: Only EX510-S□02 is applicable.

- Output unit

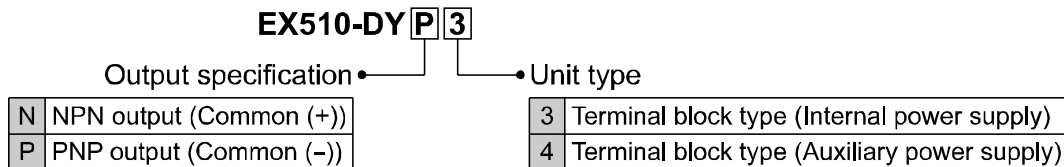

For the detail of part no. of solenoid valve manifold and independent solenoid valve with SI unit, refer to Operation Manual or other equivalent documents of used solenoid valve.

## Summary of Product Parts

### •System structure

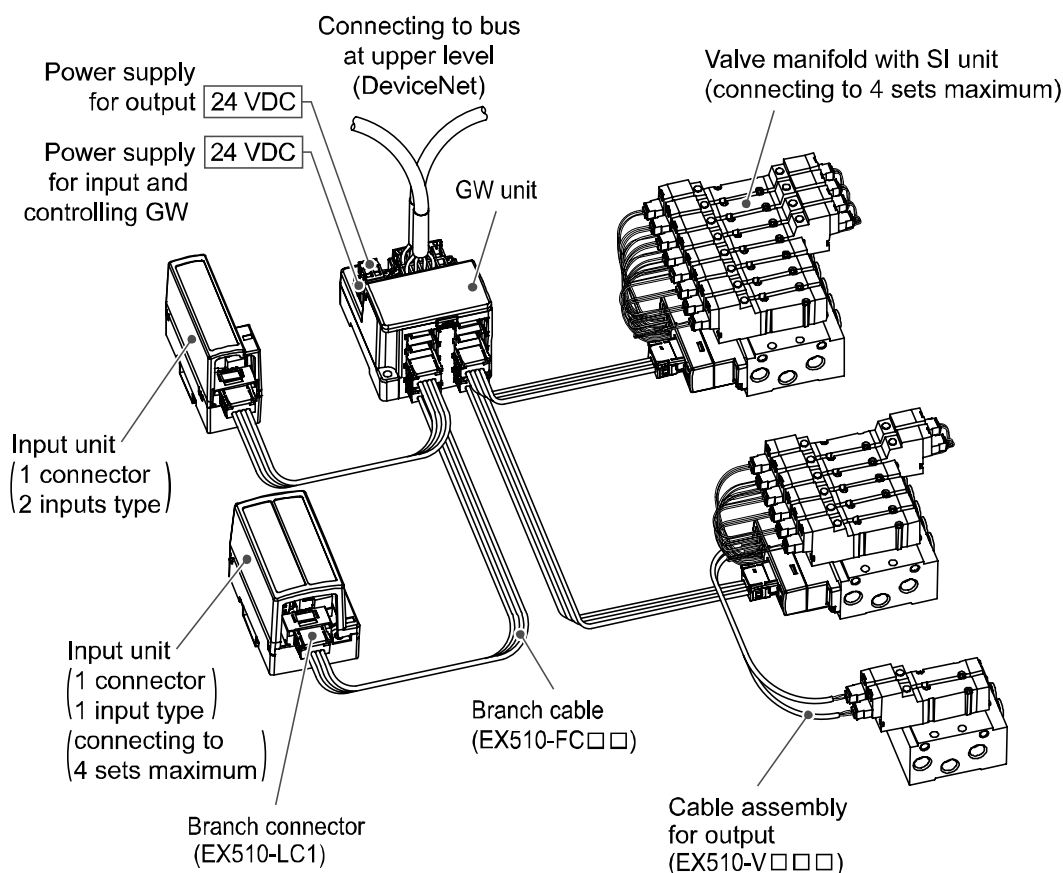

- Capable of decentralized control of 64 input points/64 output points.  
Decentralized control of 4 input branches (maximum points of 16 x 4 branches) and 4 output branches (maximum points of 16 x 4 branches) per one GW unit is possible.
- Easy setting and wiring  
Slave side does not need switch settings, but GW unit needs them such as address setting.  
It is possible to adjust length of branch cable and crimp branch cable without dedicated tool.  
Each slave does not need individual power supply because the branch cable is 4-core flat cable including a power supply line.
- Compact design  
Small and compact design is applied for all of GW unit which realizes decentralized control, Input unit which connects input equipments such as sensor, and SI unit which connects output equipment such as solenoid valve.
- Flexible setting of number of occupied station  
Utilize I/O point effectively by setting number of occupied station of GW unit.
- Applicable to each type of solenoid valves  
SMC's solenoid valves can be easily wired for serial communication.  
(See Manifold Valve for applicable valve.)  
The extra output of SI unit can be used to actuate 2-port valve etc, with a cable assembly for output.

## ■ Definition and terminology

	Terms	Meaning
A	Address (Station address)	A number allocated to identify the unit connected on the CC-Link network. It is not allowed to be duplicated.
B	Branch wiring	A method to branch and connect a communication line and power line from GW unit to SI unit and Input unit.
C	Communication connector	A connecting part to transmit a communication signal which goes and returns between equipments in field bus.
	Communication port	A connection port to distribute a communication line and power line from GW unit to SI unit and Input unit.
	Communication speed	A speed at which data is sent and received in field bus etc. It depends on an equipment (PLC etc.) at high side and is indicated by bps (bit per second).
	Connector lock pin	A pin that prevents the connector for connecting load to be connected to SI unit from coming off.
	Conductor resistance	A electric resistance of a conductor. It is a value to show ease of current flow.
	Current consumption	A current necessary to operate a product normally. In this case, the current applied to a load is not included.
	Current sink type (NPN output)	An output configuration of an input equipment which uses NPN transistor for signal outputting part. It sinks current with input and that is the reason why it is called sink.
	Current source type (PNP output)	An output configuration of an input equipment which uses PNP transistor for signal outputting part. It sources current with input and that is the reason why it is called source.
D	Data rate	An amount of data which can be sent from one equipment to the other equipment. Referred to as transmission speed of data.
	DIN rail	A metallic rail conforming with DIN (German Federation) standard.
E	Enclosure (IP)	An abbreviation of Ingress Protection. It is a standard related to protection of a product from foreign matters (hand, steel ball, steel wire, dust, water etc.).
F	FG	An abbreviation of frame ground meaning a body ground. Used to show a ground simply.
	Field bus	A standard which uses digital communication to transmit a signal between an equipment running at factory and field (instrumentation and operation equipment) and controller.
G	GND	An abbreviation of ground meaning reference voltage for signal. It has a same potential level as a shield wire (sheath) of signal line and connector and is referred to as a reference potential to transmit an electrical signal.
	GW unit	A unit used to connect protocols conforming with different standards in one network. In this system, it is regarded as a unit to adjust between CC-Link protocol and SMC dedicated protocol and connect them.
I	Impedance	A resistance generated when alternating current is applied to a circuit. Referred to as alternating current resistance.
	Input delay time	Refer to "Transmission delay".
	Input point	The number of point which can receive information from an input equipment (sensor, switch etc.).

	Terms	Meaning
L	LED	An abbreviation of Light Emitting Diode meaning a kind of semiconductor element which emits light when current is applied.
N	NPN output	An output configuration which operates an output equipment by using NPN transistor. Referred to as positive common type because positive potential is applied to common wire of power supply.
	Number of occupied slaves	Number of stations on a network used by a slave. Depending on the data, 1 to 4 stations can be set. Remote I/O occupies 1 station only.
M	Manifold	A component used to join many valves into one.
O	Opt-coupler insulation	A method for insulation by converting an electric signal to an optic signal once and using an element called opt-coupler which shows "1" and "0" when turned on and off. An opt-coupler has a part to convert an electric signal to an optic signal or opposite of it and so can be separated electrically and insulated.
	Output point	The number of point which can operate an output equipment (solenoid valve, light and motor starter etc.)
P	PLC (Programmable Logic Controller)	An abbreviation of Programmable Logic Controller. It controls timely along with a program for logic algorithm, sequential operation and arithmetic operation.
	PNP output	An output configuration which operates an output equipment by using PNP transistor. Referred to as negative common type because negative potential is applied to common wire of power supply.
	Power supply connector	A connecting part to apply power to a product.
	Power supply voltage range	A range of power supply voltage to operate a product normally.
R	Rated voltage	A optimum value of power supply voltage applied to a product. It can ensure normal operation of a product with this voltage in specified operating environment.
	Remote I/O	A slave which can only use bit data. Occupy 1 station only. General description for slave such as a digital input and digital output.
S	Serial transmission	A method to enable large information to be sent and received sequentially in one communication line by aligning them in line.
	Short protection	A method to protect an internal circuit from being damaged when power supply and GND terminal are shorted.
	SI unit	An abbreviation of serial interface. It sends and receives data by bit through a couple of signal lines, convert it to parallel and correspondingly control connected load. (A serial-to-parallel converting unit)
	Slave station	General term for a station excepting the master station.
	Station number	Numbers from 1 to 64, which are assigned to the slave stations. No. 0 is assigned to the master of CC-Link. The slave stations must be assigned concerning the number of occupied stations so that they will not duplicate.
T	Terminating resistor	A resistor mounted on both ends of wiring for connecting equipment to field bus. It prevents reflection of a signal at the end and subsequent disturbance of the signal.
	Total of station	Total number of occupied stations among the all slave stations connected with CC-Link.
	Transmission delay	A time delay from when a specified input passes a reference point until when an output reaches the reference point.

## Common Specifications

### •EX510 series common specifications

Item	Specification
Rated voltage	24 VDC
Allowable instantaneous electrical stop	1 msec. or less
Enclosure	IP20
Applicable standard	UL/CSA, CE
Withstand voltage	500 VAC 1 minute (between FG and external terminal block)
Insulation resistance	10 MΩ or more (500 VDC is given between FG and external terminal block)
Ambient temperature	Operating: -10 to 50 °C Storage: -20 to 60 °C
Ambient humidity	35 to 85%RH (No dew condensation)
Operating atmosphere	No corrosive gas
Pollution degree	Pollution degree 3 *

\*: This product is IP20 rated.

When operating this product in a pollution degree 3 environment, mount it onto an IP54 rate or higher controller board etc.

# EX510 GW unit

## Summary of Product Parts

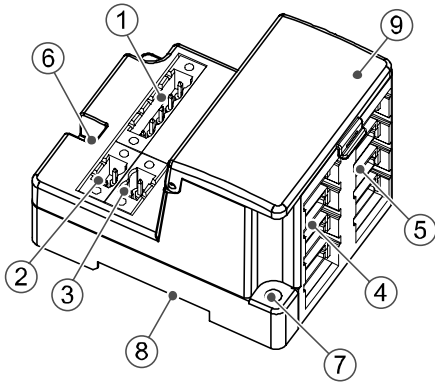

### Accessory

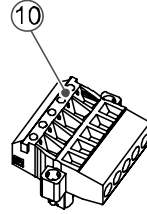

Communication connector for CC-Link (1 pc.)

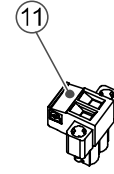

Power supply connector (2 pcs.)

No.	Element	Description
1	Communication socket (BUS)	Connect to CC-Link line with a communication connector for CC-Link (⑩).
2	Power supply socket (PWR(V))	Supplying power for output instruments such as a solenoid valve with a power supply connector (⑪).
3	Power supply socket (PWR)	Supplying power for controlling GW and for input instruments such as a sensor with a power supply connector (⑪).
4	GW unit side branch connector (for input)	Connecting an Input unit etc. by using branch cables (EX510-FC□□).
5	GW unit side branch connector (for output)	Connecting an SI unit (manifold valve) etc. by using branch cables (EX510-FC□□).
6	Ground terminal (FG)	Used for grounding.
7	Mounting hole	Used when an unit is mounted with two M4 screws.
8	DIN rail mounting slot	Used when an unit is mounted to DIN rail.
9	Display/switch setting part	Switch setting such as LED display in unit state, transmission speed, and occupied station number.

# Mounting and Installation

## ■ Installation

### •Screw installation

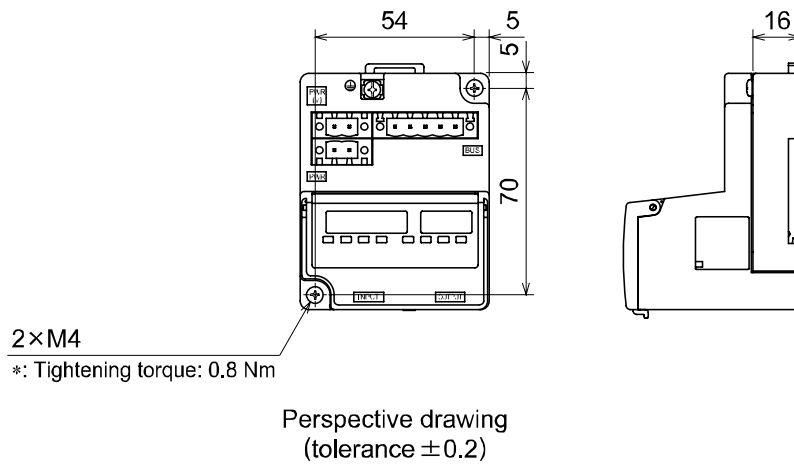

### •DIN rail installation

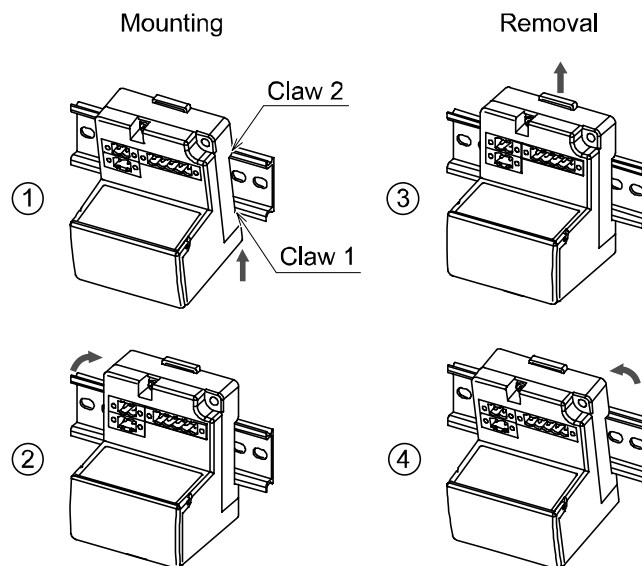

Put claw 1 of the body under DIN rail and push it upward. Push down Claw 2 to the opposite rail until the claw clicks securely on to rail. (Mounting procedure ① and ②)

For removing, lever up the DIN rail fixing plate of the body with a flat blade screwdriver, and remove it by tilting Claw 2 side forward. (Removal procedure ③ and ④)

## ■ Wiring

### ● Internal circuit and wiring

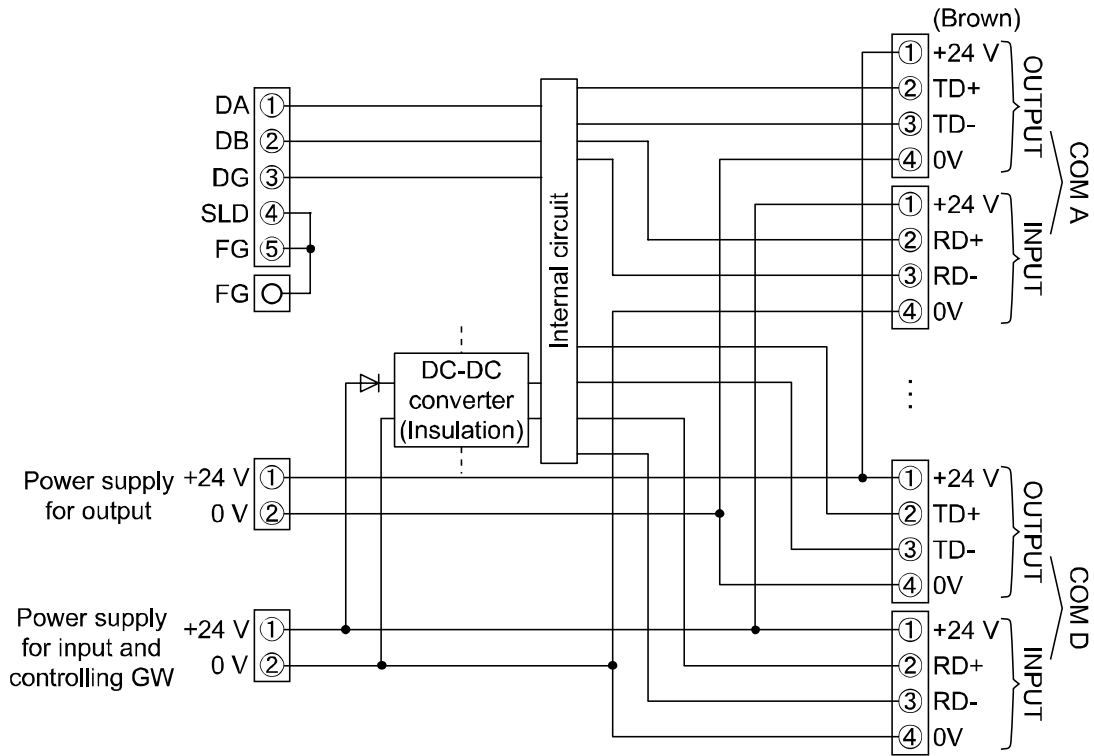

The wirings are described in the following order.

**1. Communication wiring:** Connection with CC-Link.



**2. Power supply wiring:** Connections of power supplies for output and input devices and controlling GW.



**3. Branch wiring:** Connection from GW unit to SI unit or Input unit.

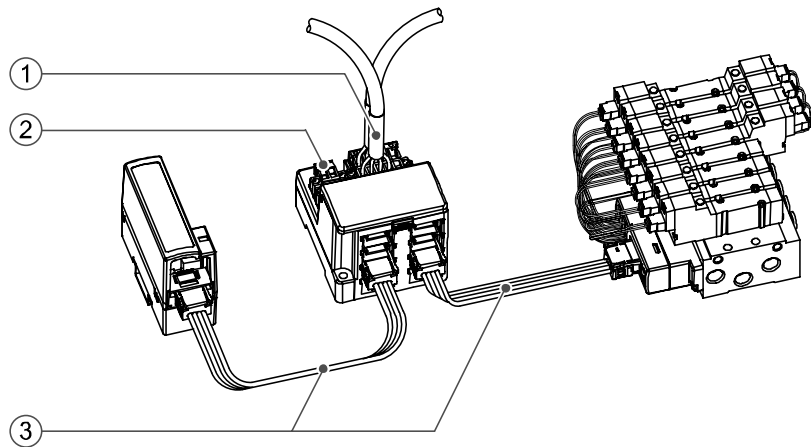

## 1. Communication wiring

The method to connect a CC-Link dedicated cable and a GW unit CC-Link communication connector is shown below.

### Connecting cable

- Make sure to connect the signal cables to designated pins (Refer to Fig. 1).  
And tighten the connector surely to 0.5 to 0.6 Nm tightening torque.
- Make sure to connect "terminating resistor" between "DA"- "DB" to the units at the both ends of the system.  
(Refer to Fig. 3)
- The connected terminating resistor differs depending on used cable in system.  
See the table below.

Cable type	Terminal resistor
CC-Link dedicated cable	110 Ω 1/2 W (brown, brown, brown)
CC-Link dedicated cable compatible with Ver.1.10	
CC-Link dedicated high performance cable	130 Ω 1/2 W (brown, orange, brown)

- Refer to Fig. 4 about how to connect to the unit.  
Tighten the connector securely to 0.5 to 0.6 Nm tightening torque.

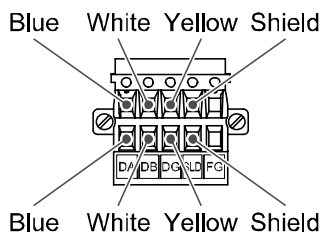

Fig. 1

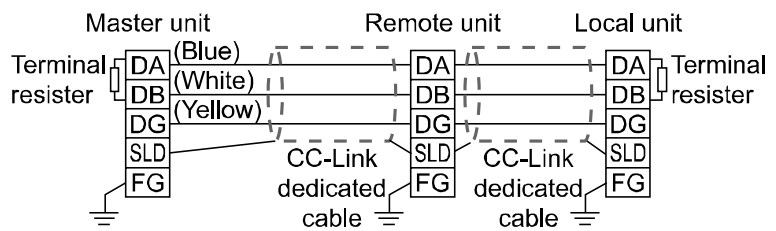

Fig. 2

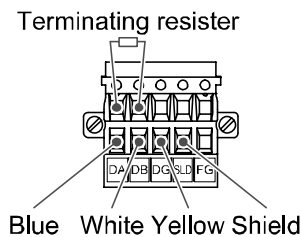

Fig. 3

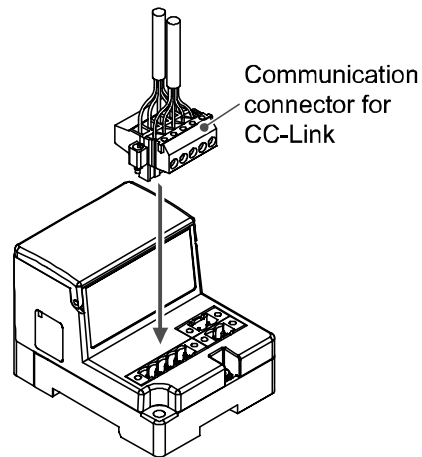

Fig. 4

### NOTE

1. CC-Link dedicated high performance cable cannot be mixed with other cables (CC-Link dedicated cable, CC-Link dedicated cable compatible with Ver.1.10).  
If mixed, normal transmission of data cannot be assured.
2. Connect the shield line of CC-Link dedicated cable to "SLD" of each unit.

## 2. Power supply wiring

Connect power supply wiring to the two power supply 2-pin connectors. Power supply consists of 2 systems, but they it can be used with both of single power supply and separate power supplies. Also, other units do not need individual power supply. Make sure of connection with the designated pin. Tighten the connector securely to 0.5 to 0.6 Nm tightening torque. Refer to Fig. 4 about how to connecting. When SI unit etc. (EX510-S□0□) is used besides the external power supply type Output unit, it is necessary to supply power for output to the GW unit and the Output unit.

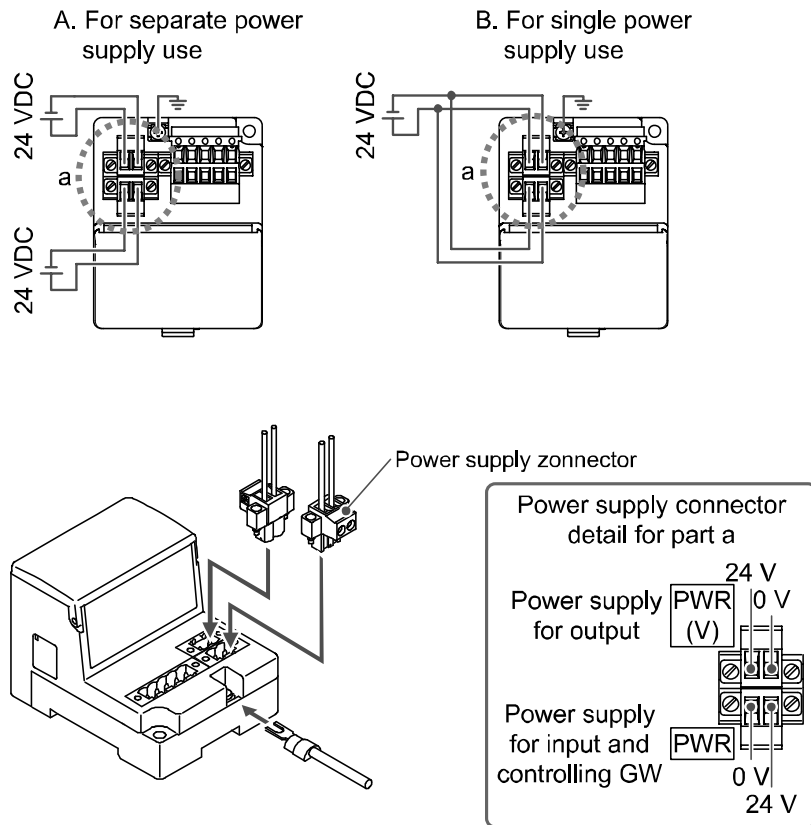

Fig. 4

### NOTE

Ground the FG terminal.

### 3. Branch wiring

Each unit is wired with a branch cable, and connected with a branch connector.  
Two branch connectors are attached to each of SI unit, Input unit and Output unit.

#### Pressure welding for branch connector

The method of pressure welding for branch connector is explained.

**Components**

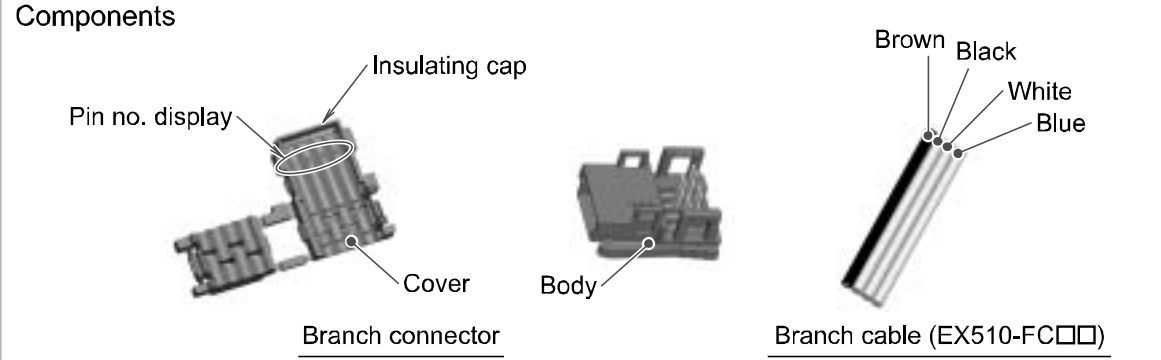

**Working procedure**

- ① Set a branch cable to the cover.  
(1) Set the brown wire of the branch cable so that it comes to the pin #1.  
(2) Meet the cable end to the insulating cap at the cover.
- ② Fix to the body tentatively  
Fit 4 latches on the body to 4 ditches on the cover, and press them until the latch engages to the level 1.
- ③ Press  
Press the cover to the body with plier etc.
- ④ Confirmation  
It is completed with a check on 4 latches engaging

③ Fold the cover so that the branch cable can be put between the cover.  
④ Fix the latch tip by inserting to a hole for fixing latch.

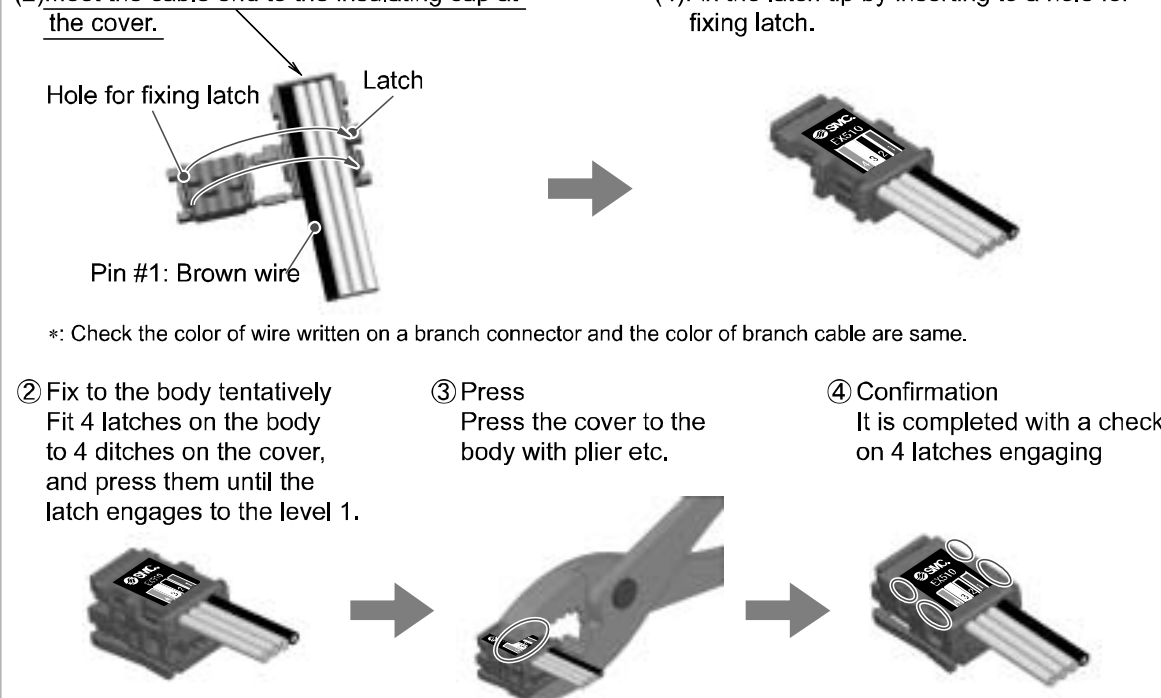

\*: Check the color of wire written on a branch connector and the color of branch cable are same.

### Wiring of branch cables

How to connect branch cable is shown below.

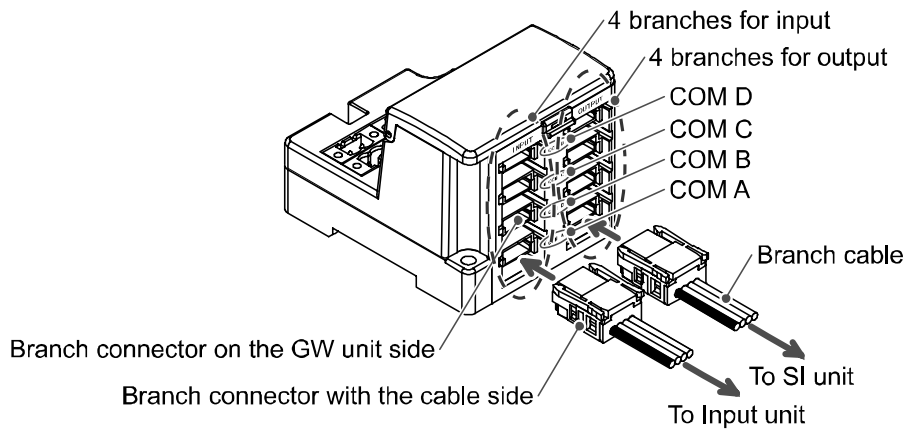

Connect the branch connectors for GW unit in order from the bottom one (COM A, B, C, and D).

## Setting

### •Display for setting

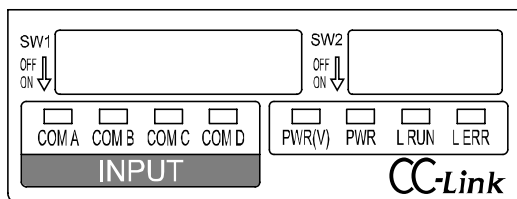

Display	Contents
PWR(V)	The power for output is supplied at specified voltage: Lights up The power for output is not supplied at specified voltage: Goes off
PWR	The power for input and controlling GW is supplied: Lights up The power for input and controlling GW is not supplied: Goes off
L RUN	Normally communication: Lights up Communication interrupted: Goes off
L ERR	Communication error: Light up Setting of station number and of transmitting speed setting switch is changed during powered: Lights up Normally communicating: Goes off
COM A	COM A is receiving data: Light up * COM A is having no data to receive: Goes off
COM B	COM B is receiving data: Light up * COM B is having no data to receive: Goes off
COM C	COM C is receiving data: Light up * COM C is having no data to receive: Goes off
COM D	COM D is receiving data: Light up * COM D is having no data to receive: Goes off

\*: Only when Input unit (equipment) is connected and communicated normally.

•Switch setting

**NOTE**

1. Open the cover, and set DIP switch with a flat blade driver, etc.
2. Make sure that switch setting is performed with power supply turned off.
3. Be sure to perform this setting of the switch before use.

**1. Setting of address and communication speed (SW1)**

The following setting is performed with the SW1.

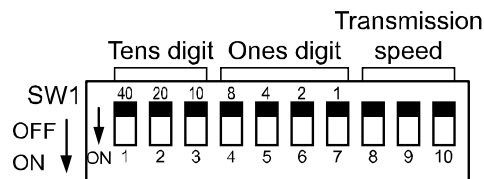

•Station number setting (Switch No.1 to 7)

Set tens digit of station number 10, 20 and 40, and set ones digit of station number 1, 2, 4 and 8. All setting are turned OFF at shipment and no station number is set. Make sure to set the station number in the range of 1 to 62 (with 3 stations occupied).

Station number	Tens digit (Switch No.)			Ones digit (Switch No.)			
	40 (No.1)	20 (No.2)	10 (No.3)	8 (No.4)	4 (No.5)	2 (No.6)	1 (No.7)
1	OFF	OFF	OFF	OFF	OFF	OFF	<b>ON</b>
2	OFF	OFF	OFF	OFF	OFF	<b>ON</b>	OFF
3	OFF	OFF	OFF	OFF	OFF	<b>ON</b>	<b>ON</b>
4	OFF	OFF	OFF	OFF	<b>ON</b>	OFF	OFF
:	:	:	:	:	:	:	:
10	OFF	OFF	<b>ON</b>	OFF	OFF	OFF	OFF
11	OFF	OFF	<b>ON</b>	OFF	OFF	OFF	<b>ON</b>
:	:	:	:	:	:	:	:
62	<b>ON</b>	<b>ON</b>	OFF	OFF	OFF	<b>ON</b>	OFF
63 *	<b>ON</b>	<b>ON</b>	OFF	OFF	OFF	<b>ON</b>	<b>ON</b>

\*: Station number 63 can be set for 2 stations occupied type.

•Swttig of communication speed (Switch No.8 to 10)

Make sure to set the transmission speed in the range as follows. All setting are turned OFF at shipment, set to 156 kbps.

Transmission speed	No.8	No.9	No.10
156 kbps	OFF	OFF	OFF
625 kbps	OFF	OFF	<b>ON</b>
2.5 Mbps	OFF	<b>ON</b>	OFF
5 Mbps	OFF	<b>ON</b>	<b>ON</b>
10 Mbps	<b>ON</b>	OFF	OFF

## 2. HOLD/CLR setting/setting of the number of stations occupied/mode setting (SW2)

The following setting is performed with the SW2.

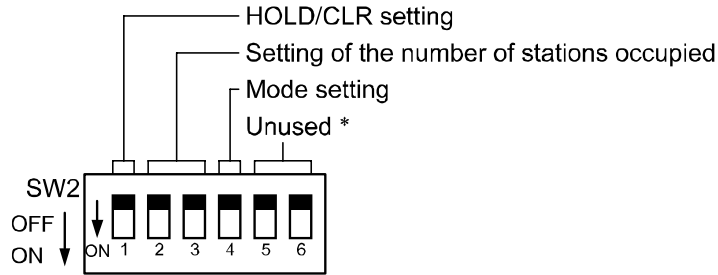

\*: Switch No.5 and No.6 are unused. (Turn them OFF.)

### ●HOLD/CLR setting (Switch No.1)

The setting is as follows.

The setting at shipment is turned OFF, set to CLR.

HOLD/CLR	No.1	Function
CLR	OFF	Output is cleared when an error occurs.
HOLD	ON	Output is held when an error occurs.

### ●Setting of the number of stations occupied (Switch No.2 to 3)

The setting of the number of stations occupied is performed with switch No.2 to 3.

3 stations are occupied at shipment.

For further information, refer to "I/O memory map and flexible setting of number of I/O point".

Station setting	No.2	No.3	The max. available number of I/O point
2 station-occupied	OFF	ON	Input 32/ Output 32
3 station-occupied	ON	OFF	Input 64/ Output 64

### ●Mode setting (Switch No.4)

Mode setting of each port is available only when 2 stations are occupied.

No.4 is used for mode setting.

The default setting is mode A.

For further information, refer to "I/O memory map and flexible setting of number of I/O point".

Mode	No.4	Number of branch	Valid port
A	OFF	16 points per port	COM A and B
B	ON	8 points per port	COM A to D

•I/O memory map and setting of number of I/O point

In GW unit, the number of controlled I/O point can be changed with DIP switch (SW2 No. 2 to 4).

At shipment, setting to occupy 3 stations are provided.

1. Setting

Number of occupied station	Mode	The max. available number of I/O point	SW2			Number of point controlled by COM port	
			No.2	No.3	No.4	INPUT	OUTPUT
3 occupied stations	-	Input: 64/ Output: 64	ON	OFF	OFF	16 points for each of A to D	16 points for each of A to D
2 occupied stations	A mode	Input: 32/ Output: 32	OFF	ON	OFF	16 points for each of A and B	16 points for each of A and B
2 occupied stations	B mode	Input: 32/ Output: 32	OFF	ON	ON	8 points for each of A to D	8 points for each of A to D

2. Memory map

•I/O data

•3 stations occupied (Input: 64, Output: 64)

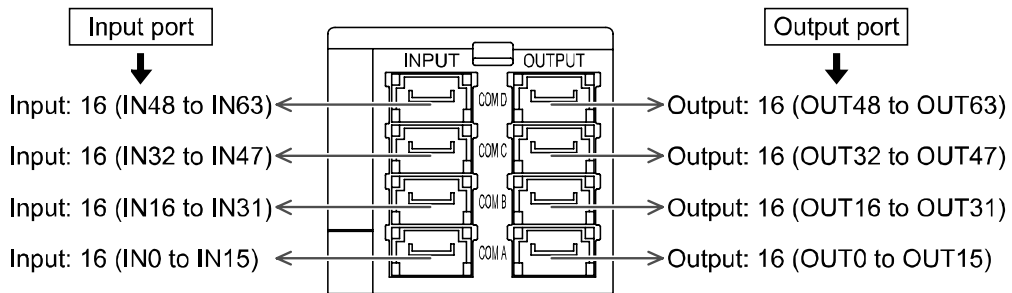

I/O memory map (in case of station number 1)

Ex.) "QJ61BT11N"

Buffer memory address	Remote input (RX)	Buffer memory address	Remote output (RY)
E0H	RX F to RX 0	160H	RY F to RY 0
	COM A (IN15 to IN0)		COM A (OUT15 to OUT 0)
E1H	RX1F to RX10	161H	RY1F to RY10
	COM B (IN31 to IN16)		COM B (OUT31 to OUT16)
E2H	RX2F to RX20	162H	RY2F to RY20
	COM C (IN47 to IN32)		COM C (OUT47 to OUT32)
E3H	RX3F to RX30	163H	RY3F to RY30
	COM D (IN63 to IN48)		COM D (OUT63 to OUT48)
E4H	RX4F to RX40	164H	RY4F to RY40
	Profile area *		It is not possible to use it.
E5H	RX5F to RX50	165H	RY5F to RY50
	Profile area *		It is not possible to use it.

\*: For detail of profile area, refer to "Profile area".

•2 stations occupied A mode (Input: 32, Output: 32)

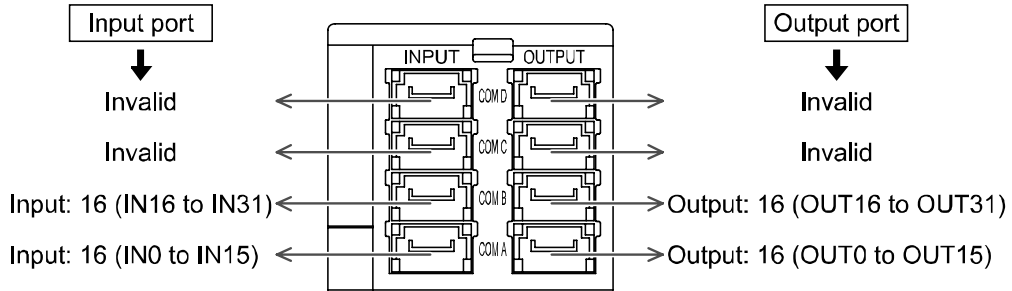

I/O memory map (in case of station No. 1)

Ex.) "QJ61BT11N"

Buffer memory address	Remote input (RX)	Buffer memory address	Remote output (RY)
E0H	RX F to RX 0	160H	RY F to RY 0
	COM A (IN15 to IN0)		COM A (OUT15 to OUT 0)
E1H	RX1F to RX10	161H	RY1F to RY10
	COM B (IN31 to IN16)		COM B (OUT31 to OUT16)
E2H	RX2F to RX20	162H	RY2F to RY20
	Profile area *		Not available
E3H	RX3F to RX30	163H	RY3F to RY30
	Profile area *		Not available

\*: For detail of profile area, refer to "Profile area".

•2 stations occupied B mode (Input: 32, Output: 32)

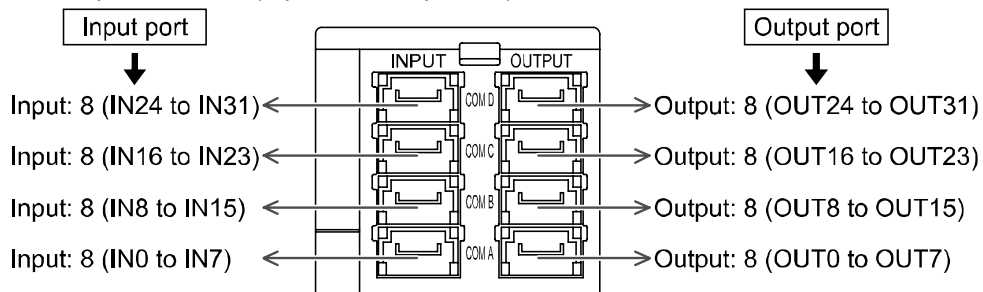

I/O memory map (in case of station No. 1)

Ex.) "QJ61BT11N"

Buffer memory address	Remote input (RX)		Buffer memory address	Remote output (RY)	
E0H	RX F to RX 8	RX 7 to RX 0	160H	RY F to RY 8	RY 7 to RY 0
	COM B (IN15 to IN 8)	COM A (IN 7 to IN 0)		COM B (OUT15 to OUT 8)	COM A (OUT 7 to OUT 0)
E1H	RX1F to RX18	RX17 to RX10	161H	RY1F to RY18	RY17 to RY10
	COM D (IN31 to IN24)	COM C (IN23 to IN16)		COM D (OUT31 to OUT24)	COM C (OUT23 to OUT16)
E2H	RX2F to RX20		162H	RY2F to RY20	
	Profile area *			Not available	
E3H	RX3F to RX30		163H	RY3F to RY30	
	Profile area *			Not available	

\*: For detail of profile area, refer to "Profile area".

## •Profile area

GW unit has the function to detect lowering of power supply for output and to diagnose the condition of input port monitor etc., and sends the detected result by using profile area shown below.

- Low output power supply detecting function ... Detecting the condition where power supply for output decreases less than 20 V and then informing it to CC-Link profile area.

This function doesn't influence error state flag and remote READY shown on the table below.

(Signal name on the table: Voltage decrease)

0: Normal

1: Abnormal

- Input port monitoring function ... Monitoring COM port of input and informing it to CC-Link profile area.

(Signal name on the table: COM A, COM B, COM C, COM D)

0: Normal

1: Abnormal

- Error state flag ... 0: Normal

1: GW unit is in start or stop condition

- Remote READY ... 1: GW unit is in start condition

- 3 stations occupied

I/O memory map (in case of station No.1)

Ex.) "QJ61BT11N"

Buffer memory address	Remote input (RX)												
	E4H	RX4F	...	RX4C	RX4B	RX4A	RX49	RX48	RX47	...	RX43	RX42	RX41
Reserve (H)			COM D	COM C	COM B	COM A	Reserve (L)			Voltage decrease	Reserve (L)		
E5H	RX5F	...	RX5C	RX5B	RX5A	RX59	RX58	RX57	...	RX53	RX52	RX51	RX50
	Reserve (L)			Remote READY	Error state flag	Reserve (L)							

Reserve (L): Reserved bit (0 fixing), Reserve (H): Reserved bit (1 fixing)

- 2 stations occupied A • B mode

I/O memory map (in case of station No.1)

Ex.) "QJ61BT11N"

Buffer memory address	Remote input (RX)												
	E2H	RX2F	...	RX2C	RX2B	RX2A	RX29	RX28	RX27	...	RX23	RX22	RX21
Reserve (H)			COM D	COM C	COM B	COM A	Reserve (L)			Voltage decrease	Reserve (L)		
E3H	RX3F	...	RX3C	RX3B	RX3A	RX39	RX38	RX37	...	RX33	RX32	RX31	RX30
	Reserve (L)			Remote READY	Error state flag	Reserve (L)							

Reserve (L): Reserved bit (0 fixing), Reserve (H): Reserved bit (1 fixing)

# Specifications

## ■ Specifications

### ● Basic specifications

Rated voltage	24VDC
Power supply voltage	Power supply for input and controlling: 24 VDC $\pm$ 10% Power supply for output: 24 VDC +10%/-5% (Warning for voltage drop is given at approx. 20 V)
Rated current	Power supply for input and controlling: Max. 4.1 A (Inside GW unit: 0.1 A) (Input unit: 4 A) Power supply for output: Max. 6 A
Input/Output point	Input point: Max. 64/Output point: Max. 64 (Changeable by switch settings)
Weight	160 g (including accessories)

### ● Higher-level bus

Compatible system	CC-Link Ver. 1.10
Number of station occupied	3 stations (for setting with input point 64/output point 64) 2 stations (for setting with input point 32/output point 32)
Station type	Remote device station

Communication speed	156 Kbps	625 Kbps	2.5 Mbps	5 Mbps	10 Mbps
Cable length between stations	20 cm and over				
Maximum extended cable length	1200 m	900 m	400 m	160 m	100 m

### ● Lower level bus

Number of branches for input/output	4 branches for input, 4 branches for output
Communication type	Communication protocol: dedicated for SMC Communication speed: 750 kbps
Current for input branch *	Max. 1 A per branch
Current for output branch	Max. 1.5 A per branch
Branch cable length	Within 20 m (See diagram right for details.)

\*: Maximum value in total of current consumption and load current of connected input equipments.

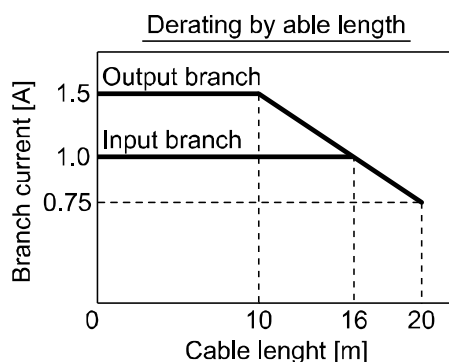

## ■Dimensions

- GW unit (EX510-GMJ1)

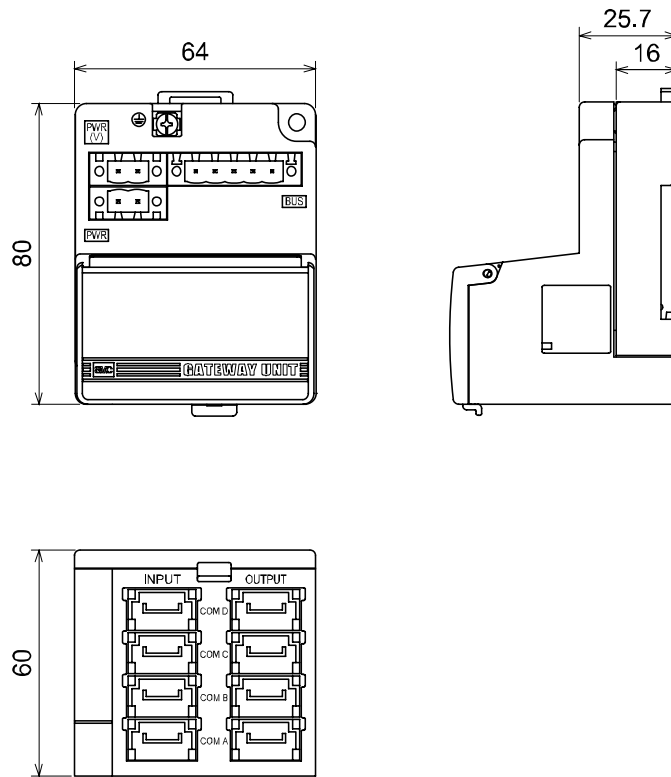

# SI unit

## Summary of Product Parts

SI unit is the unit to be combined with manifold solenoid valves to communicate with GW unit. It can be used with a plug lead type and plug in type solenoid valves.

Single solenoid valve can be operated by using empty ports. (Only for EX510-S□01□)

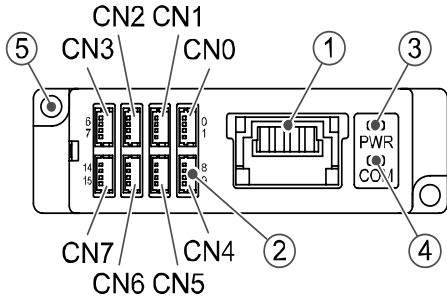

### Accessory

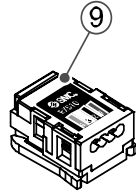

Branch connector  
(2 pcs.) (EX510-LC1)

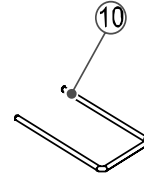

Connector lock pin  
(1 pc.) \*

\*: It is integrated into the body of the unit for EX510-S□02□.

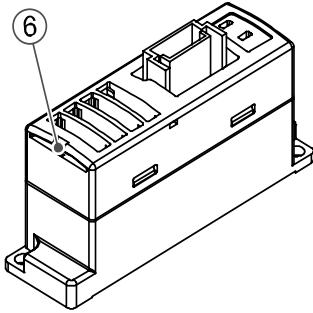

EX510-S□01

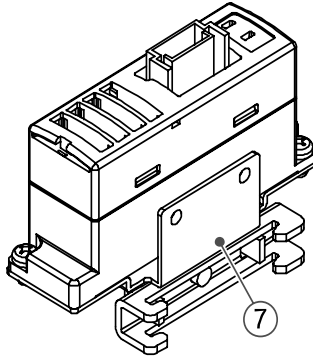

EX510-S□01B

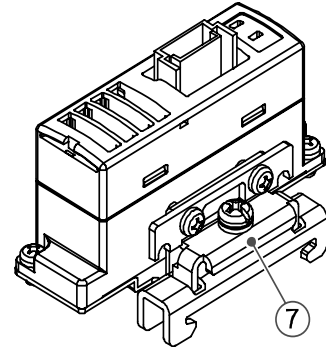

EX510-S□01A

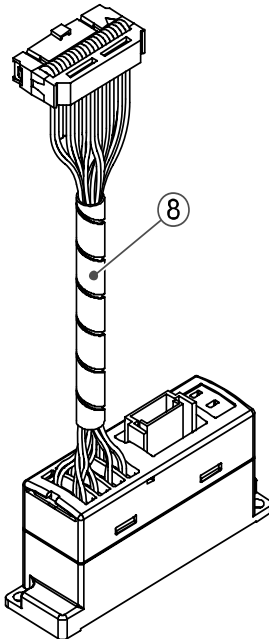

EX510-S□02

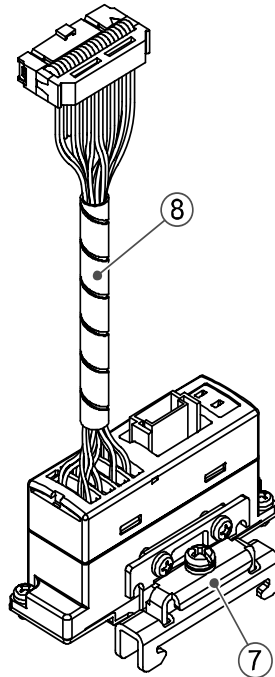

EX510-S□02A

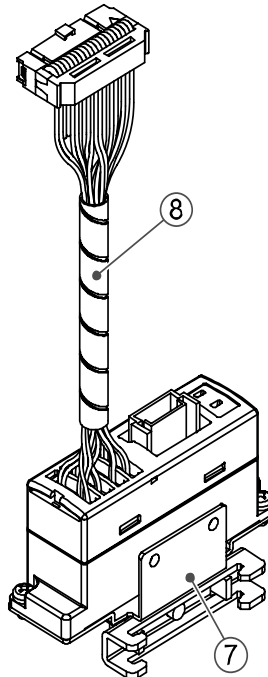

EX510-S□02B

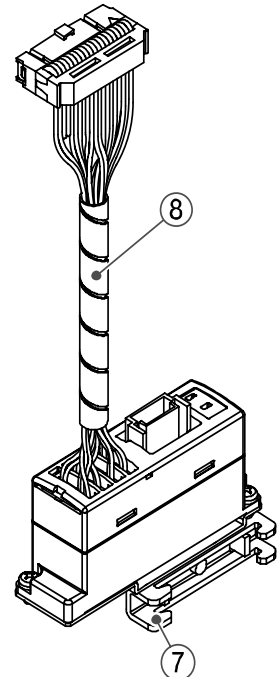

EX510-S□02C

No.	Element	Description
1	Branch connector on the SI unit side	Used to crimp branch connector (⑨) into branch cable (EX510-FC□□) and connected them to GW unit.
2	Load mounting connector	Connecting output equipment such as solenoid valve.
3	Power supply LED	Lights up: Power ON (Normal) Goes off: Power OFF
4	Communication LED	Lights up: Data received Goes off: No data received
5	Mounting hole	Used to mount the unit with two M3 screws.
6	Connector locking pin inserted hole	Receiving connector locking pin (⑩).
7	Mounting bracket	Possible to mount on DIN rail.
8	Adapter cable assembly	Connects a plug-in valve manifold. (Only for EX510-S□02□)

\*: Only mounting direction of the SI unit to the mounting bracket is different between EX510-S□□□A and EX510-S□□□B. Mounting direction can be changed from horizontal to vertical by changing the screws which construct the mounting bracket. Mounting direction of the EX510-S□02C cannot be changed to vertical as the its mounting bracket is exclusive for horizontal mounting.

# Mounting and Installation

## ■ Installation

Each SI unit is mounted and removed as shown on the following figure.

### ● Mounted by screw

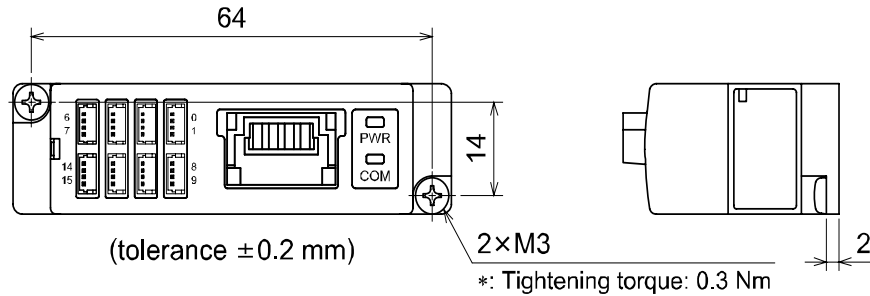

### ● Mounted on DIN rail

#### Vertical mounting

EX510-S□01A  
EX510-S□02A

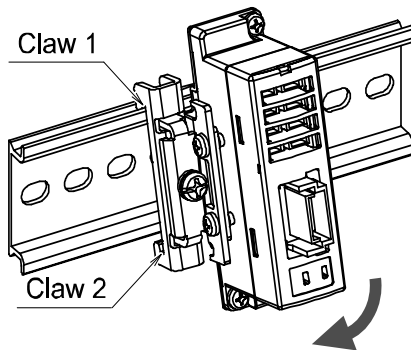

#### Horizontal mounting

EX510-S□01B  
EX510-S□02B, C

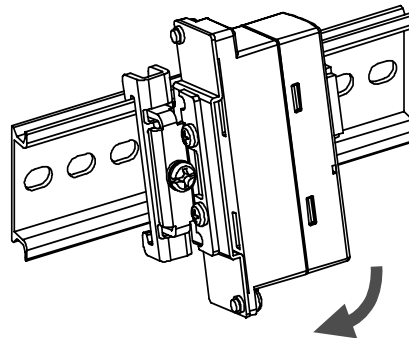

1, Hook claw 1 over the upper side and claw 2 over the low side of DIN rail respectively.

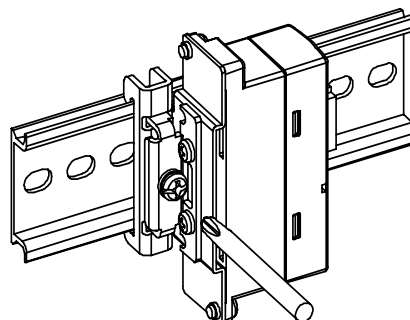
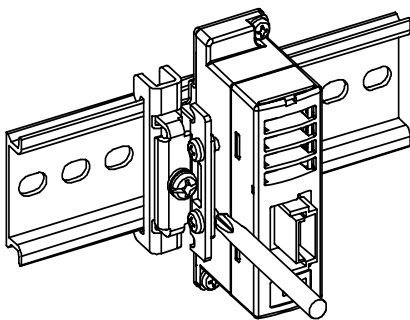

2, Tighten the screw by Phillips screw driver until DIN rail is secured. (Tightening torque: 0.6 Nm)

3, When the DIN rail is disconnected, loosen the screw and unengaged claw 2 and then claw 1 in order.

## ■Wiring

### ●Internal circuit and wiring

#### ●EX510-S001 □

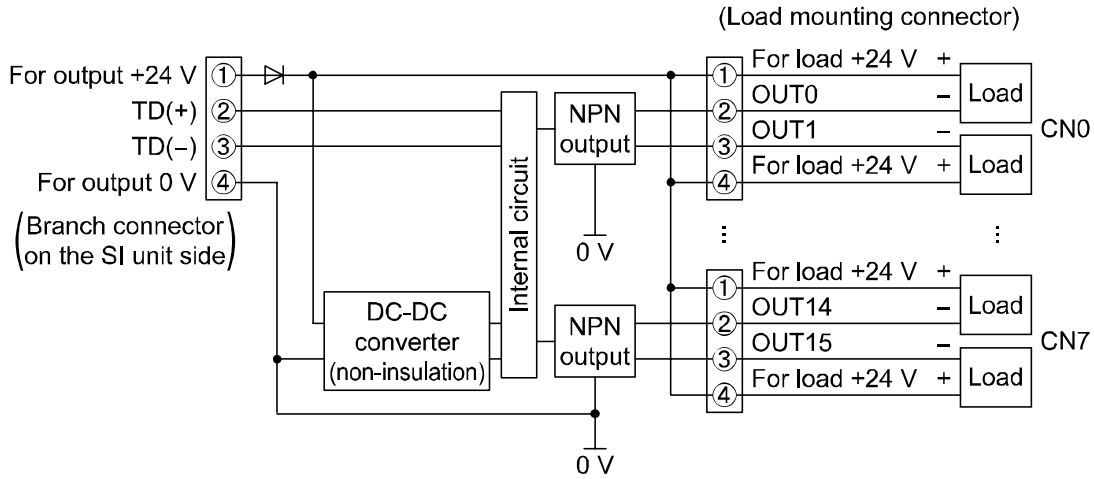

#### ●EX510-S101 □

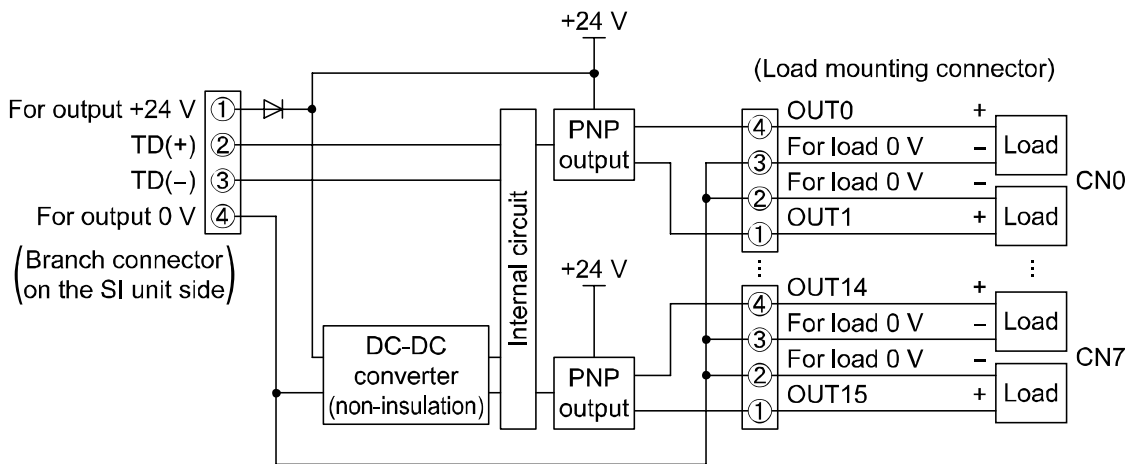

●EX510-S002□

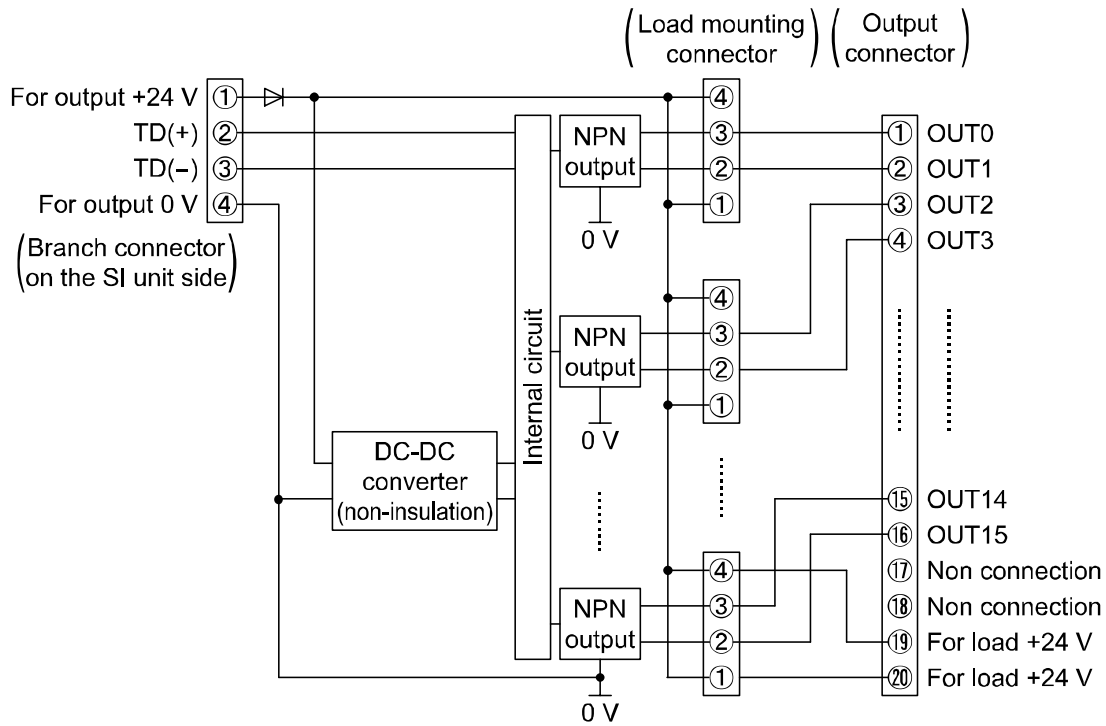

●EX510-S102□

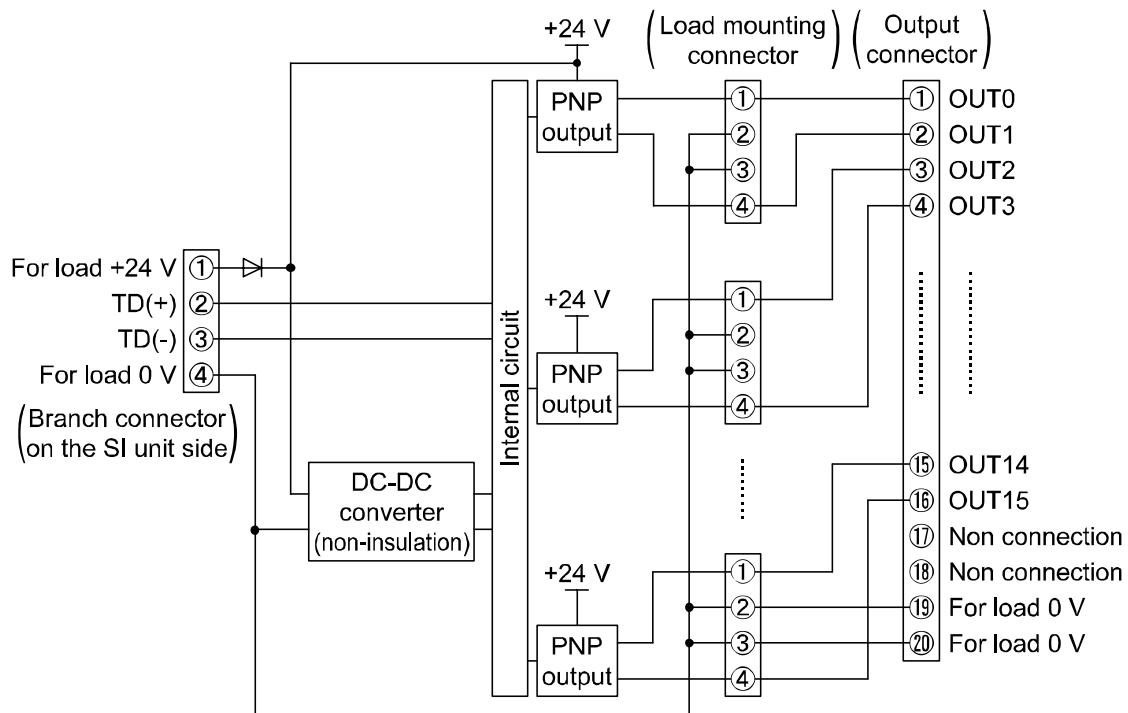

- Wiring of the branch cable and connector for connecting load  
(Connector for connecting load: Applicable only to EX510-S □ 01 □ )
- Wiring of branch cables and load mounting connector are shown below.
- Insert load mounting connector with pinsette. After insertion at all load mounting connectors is completed, insert connector locking pin. The output no. of each load mounting connector can be found on the below.

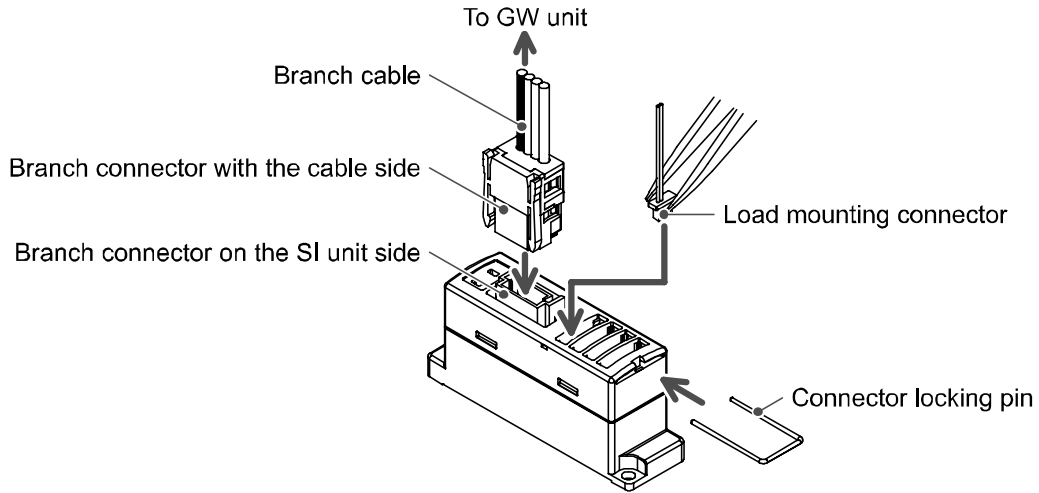

\*: For crimping of a branch connector, refer to page 17.

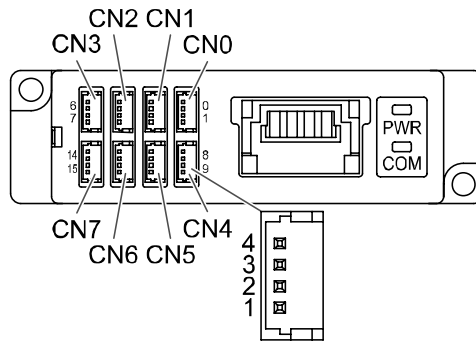

### •Load connecting connector pin assignment (EX510-S □ 01 □ )

#### •EX510-S001 □

No.	Name	Function							
		CN0	CN1	CN2	CN3	CN4	CN5	CN6	CN7
4	COM	Load actuating common (+)							
3	Output (n)	OUT0	OUT2	OUT4	OUT6	OUT8	OUT10	OUT12	OUT14
2	Output (n+1)	OUT1	OUT3	OUT5	OUT7	OUT9	OUT11	OUT13	OUT15
1	COM	Load actuating common (+)							

#### •EX510-S101 □

No.	Name	Function							
		CN0	CN1	CN2	CN3	CN4	CN5	CN6	CN7
4	Output (n)	OUT0	OUT2	OUT4	OUT6	OUT8	OUT10	OUT12	OUT14
3	COM	Load actuating common (-)							
2	COM	Load actuating common (-)							
1	Output (n+1)	OUT1	OUT3	OUT5	OUT7	OUT9	OUT11	OUT13	OUT15

●Output connector (MIL20pin) pin assignment (EX510-S□02□)

●EX510-S002□

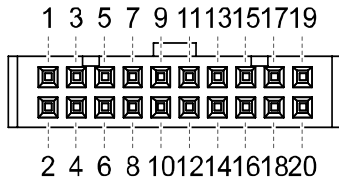

Terminal No.	1	3	5	7	9	11	13	15	17	19
Output No.	0	2	4	6	8	10	12	14	-	24 V
Type	-	-	-	-	-	-	-	-	-	+COM
Terminal No.	2	4	6	8	10	12	14	16	18	20
Output No.	1	3	5	7	9	11	13	15	-	24 V
Type	-	-	-	-	-	-	-	-	-	+COM

●EX510-S102□

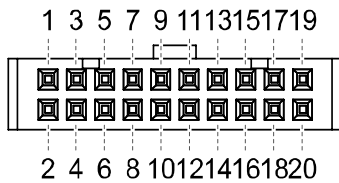

Terminal No.	1	3	5	7	9	11	13	15	17	19
Output No.	0	2	4	6	8	10	12	14	-	0 V
Type	+	+	+	+	+	+	+	+	-	-COM
Terminal No.	2	4	6	8	10	12	14	16	18	20
Output No.	1	3	5	7	9	11	13	15	-	0 V
Type	+	+	+	+	+	+	+	+	-	-COM

\*: Only a flat cable type manifold (P kit) can be connected to EX510-S□02□.  
It cannot be connected to PCW type (G/J kit) according to the different pin assign.

●Use of remaining output (Only for EX510-S□01□)

Remaining output of SI unit can be used by using a cable assembly for output.  
(Refer to the figure below.)

Refer to "SI unit specifications" on page 31 for the load current restriction of SI unit.

Power consumption of each valve series is shown in the table below.  
Refer to the catalog of each valve series for detail.

Valve series	Power consumption
SY3000/5000/7000/9000	Standard: 0.4 W (approx. 17 mA) With power saving circuit: 0.1 W (approx. 4 mA)
SYJ3000/5000/7000	Standard: 0.4 W (approx. 17 mA) With power saving circuit: 0.1 W (approx. 4 mA)
VQZ1000/2000/3000	Standard: 1.0 W (approx. 42 mA) Low wattage: 0.5 W (approx. 21 mA)

Refer to "Wiring of the branch cable and connector for connecting load" on page 29 for how to wire the cable assembly for output.

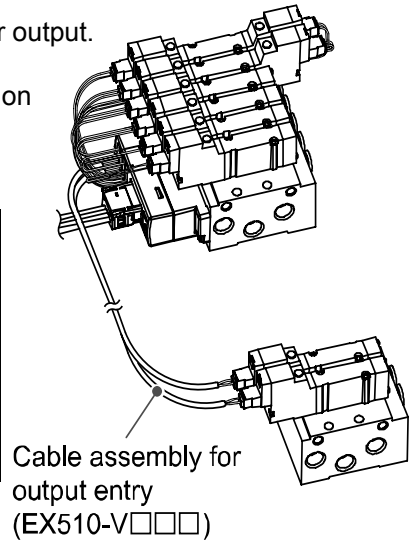

**NOTE**

Do not pull the cable assembly for output strongly. It can cause defective connection or broken wire.

## Setting

### •Setting of display

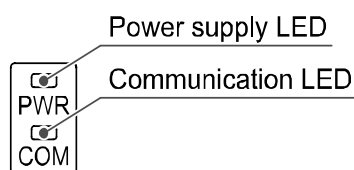

Display	Contents
Power supply LED	Lights up: The power for output is supplied at specified voltage. Goes off: The power for output is not supplied at specified voltage.
Communication LED	Lights up: Data is being received from a GW unit Goes off: No data is being received.

## Specifications

### ■Specifications

#### •SI unit specifications

Item	Specification	
Model No.	EX510-S001□, EX510-S002□	EX510-S101□, EX510-S102□
Output type	NPN output (Sink type)	PNP output (source type)
Number of output points	16 points	
Rated load voltage	24 VDC	
Max. load current	Meet the three following conditions: (1) 1 point: 0.25 A or less (2) 1 unit: 1.4 A or less (3) Total current of OUT0 to OUT7: 1 A or less, Total current of OUT8 to OUT15: 1 A or less	
Protection	Built-in protection circuit for short circuit	
Current consumption	50 mA or less (inside of SI unit)	
Weight	EX510-S□01: 40 g/EX510-S□01A, B: 80 g/EX510-S□02: 50 g EX510-S□02A, B, C: 90 g (including accessories)	

#### •Applicable solenoid valve series

The following manifold valve can be used for EX510 series.

#### •Non-plug in type

Valve series	Model No.
SY	3000, 5000, 7000, 9000
SYJ	3000, 5000, 7000
S0700	0700
VQZ	1000, 2000, 3000

#### •Plug-in type

Valve series	Model No.
SJ	2000, 3000
SZ	3000
SY	3000, 5000
SQ	1000, 2000
VQ	1000, 2000

Refer to the catalogs and Operation Manual of each valve series for solenoid valve and manifold, etc.

## ■ Dimensions

### ● EX510-S□01

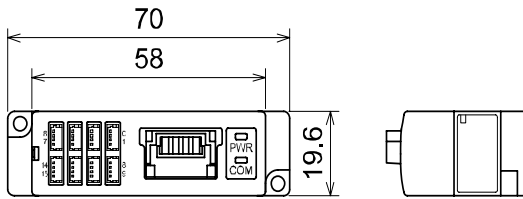

### ● EX510-S□01A

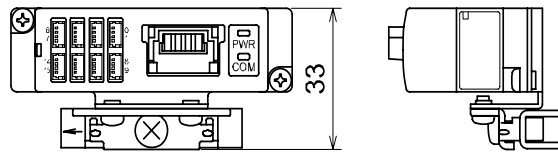

### ● EX510-S□01B

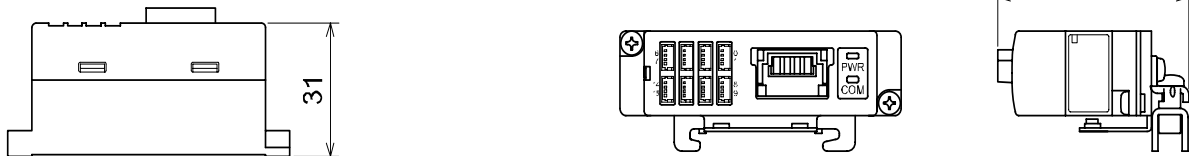

### ● EX510-S□02

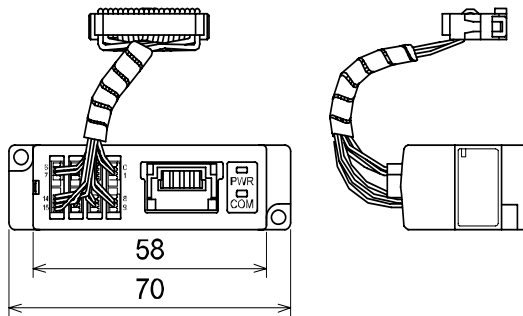

### ● EX510-S□02A

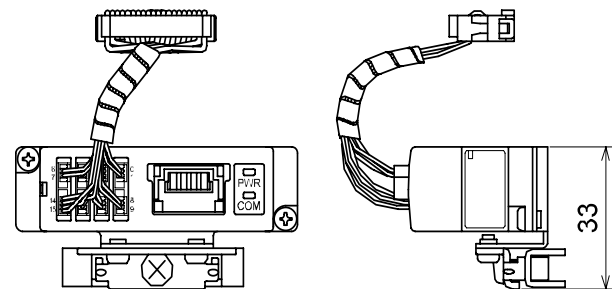

### ● EX510-S□02B

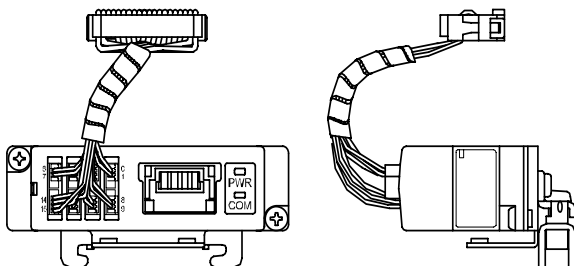

### ● EX510-S□02C

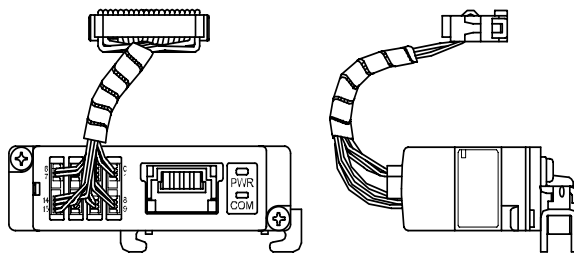

Refer to the catalogs and Operation Manual of each valve series for dimensions of the manifold valve.

# Output unit

## Summary of Product Parts

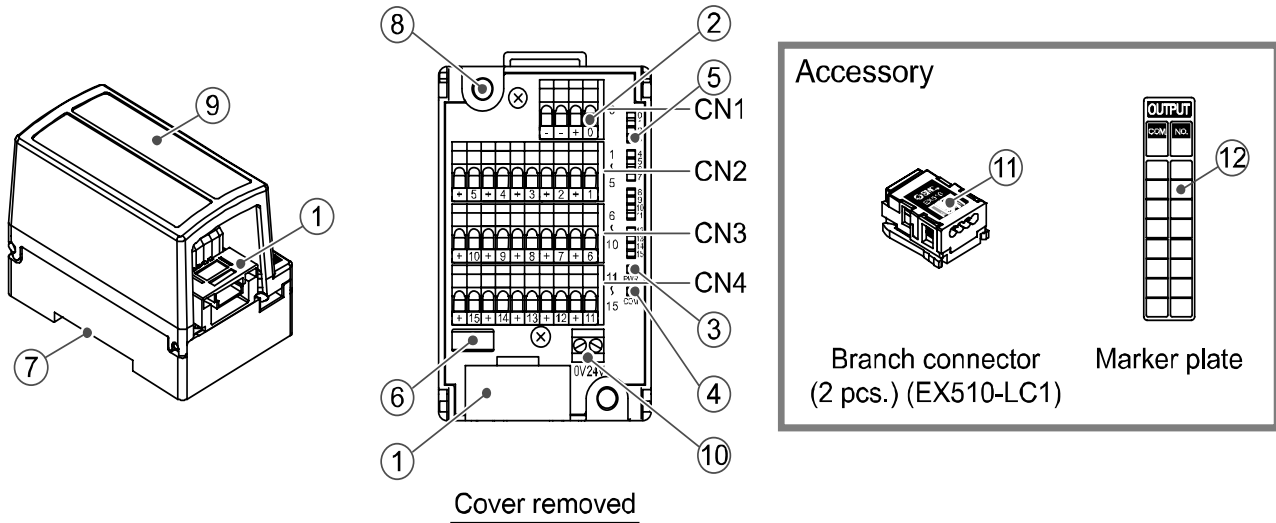

No.	Element	Description
1	Branch connector on the Output unit side	Used to crimp branch connector (⑪) into branch cable (EX510-FC□□) and connected them to GW unit.
2	Output terminal block	Used to connect output load, etc.
3	Power supply LED	Lights up: Power ON (normal) Goes off: Power OFF
4	Communication LED	Lights up: Receiving data Goes off: No communication data
5	Display LED	Lights up: Output signal ON Goes off: Output signal OFF
6	Fuse	Fuse is replaceable.
7	Mounting slot	Used to mount DIN rail on the unit.
8	Mounting hole	The unit is mounted by two M4 screws.
9	Cover	Used to protect cable and provided with marker plate (⑫) on the top.
10	Terminal block for auxiliary power supply	Used to supply power for the loads. (EX510-DYN4, EX510-DYP4)

# Mounting and Installation

## ■ Installation

- Mounted by screw

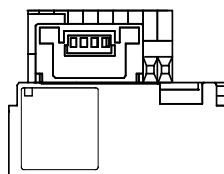
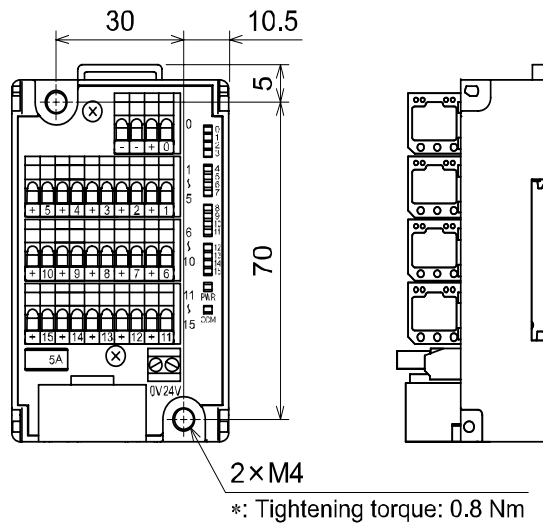

Cover removed (tolerance  $\pm 0.2$  mm)

- Mounted on DIN rail (Common for EX510-DX □ 1 and 2)

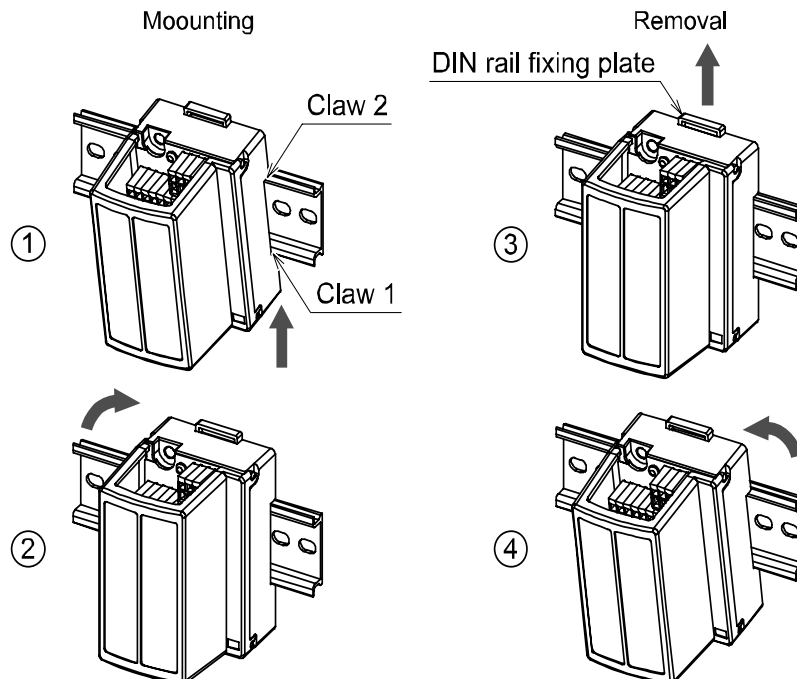

Put claw 1 at the body under DIN rail and push it upward. Push down claw 2 to the opposite rail unit the claw clicks to be set stably. (Mounting procedure ① and ②)  
 For removing, push up DIN rail fixing plate at the body with a flat screwdriver, and remove it by tilting claw 2 side forward. (Removal procedure ③ and ④)

## ■ Wiring

### ● Internal circuit and wiring

#### ● EX510-DYN3: Output unit for NPN (Internal power supply type)

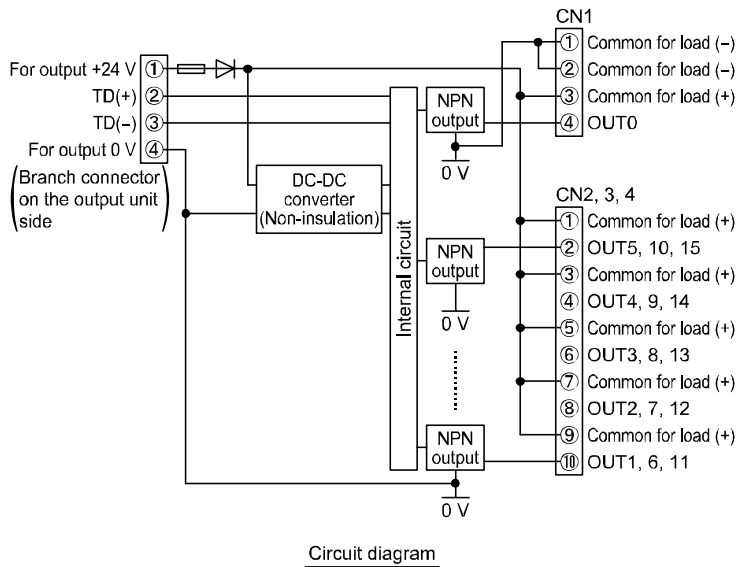

Terminal connector (CN1)



No.	Name	Function	
		CN1	
1	COM	Common for load (-)	
2	COM	Common for load (-)	
3	COM	Common for load (+)	
4	Output	OUT0	

Terminal connector (CN2, CN3, CN4)

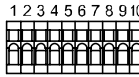

No.	Name	Function		
		CN2	CN3	CN4
1	COM	Common for load (+)		
2	Output	OUT5	OUT10	OUT15
3	COM	Common for load (+)		
4	Output	OUT4	OUT9	OUT14
5	COM	Common for load (+)		
6	Output	OUT3	OUT8	OUT13
7	COM	Common for load (+)		
8	Output	OUT2	OUT7	OUT12
9	COM	Common for load (+)		
10	Output	OUT1	OUT6	OUT11

#### ● EX510-DYN4: Output unit for NPN (Auxiliary power supply type)

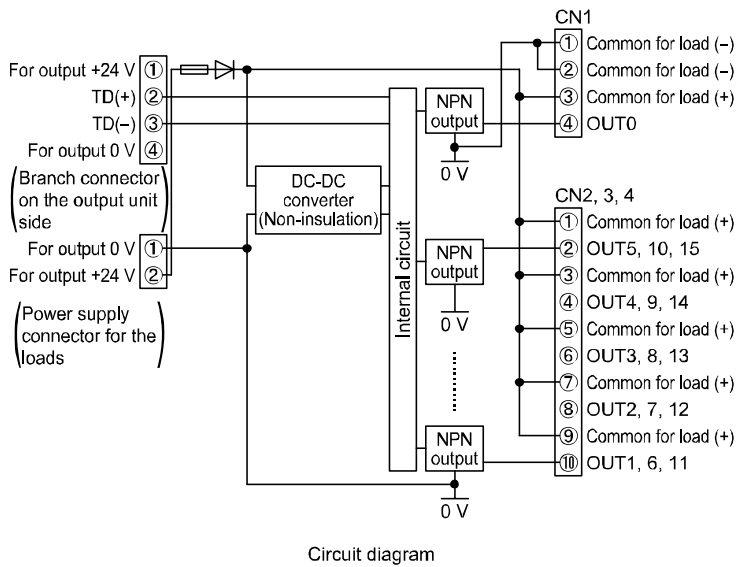

Terminal connector (CN1)



No.	Name	Function	
		CN1	
1	COM	Common for load (-)	
2	COM	Common for load (-)	
3	COM	Common for load (+)	
4	Output	OUT0	

Terminal connector (CN2, CN3, CN4)

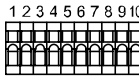

No.	Name	Function		
		CN2	CN3	CN4
1	COM	Common for load (+)		
2	Output	OUT5	OUT10	OUT15
3	COM	Common for load (+)		
4	Output	OUT4	OUT9	OUT14
5	COM	Common for load (+)		
6	Output	OUT3	OUT8	OUT13
7	COM	Common for load (+)		
8	Output	OUT2	OUT7	OUT12
9	COM	Common for load (+)		
10	Output	OUT1	OUT6	OUT11

●EX510-DYP3: Output unit for PNP (Internal power supply type)

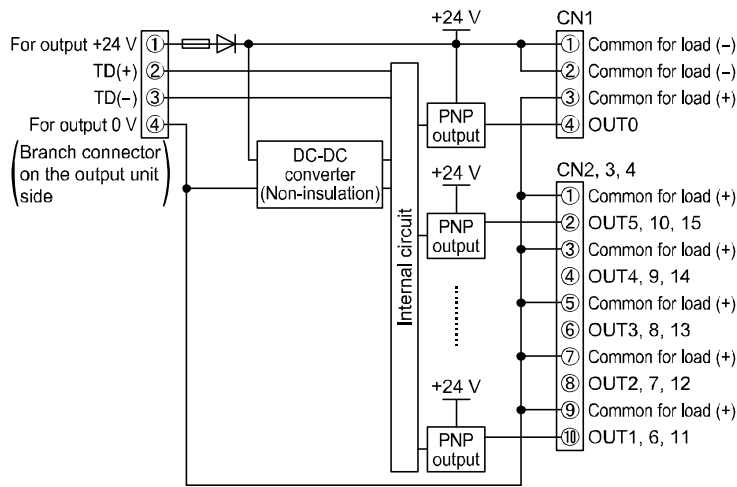

Circuit diagram

Terminal connector (CN1)



No.	Name	Function
CN1		
1	COM	Common for load (+)
2	COM	Common for load (-)
3	COM	Common for load (-)
4	Output	OUT0

Terminal connector (CN2, CN3, CN4)

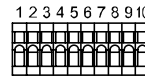

No.	Name	Function		
		CN2	CN3	CN4
1	COM	Common for load (-)		
2	Output	OUT5	OUT10	OUT15
3	COM	Common for load (-)		
4	Output	OUT4	OUT9	OUT14
5	COM	Common for load (-)		
6	Output	OUT3	OUT8	OUT13
7	COM	Common for load (-)		
8	Output	OUT2	OUT7	OUT12
9	COM	Common for load (-)		
10	Output	OUT1	OUT6	OUT11

●EX510-DYP4: Output unit for PNP (Auxiliary power supply type)

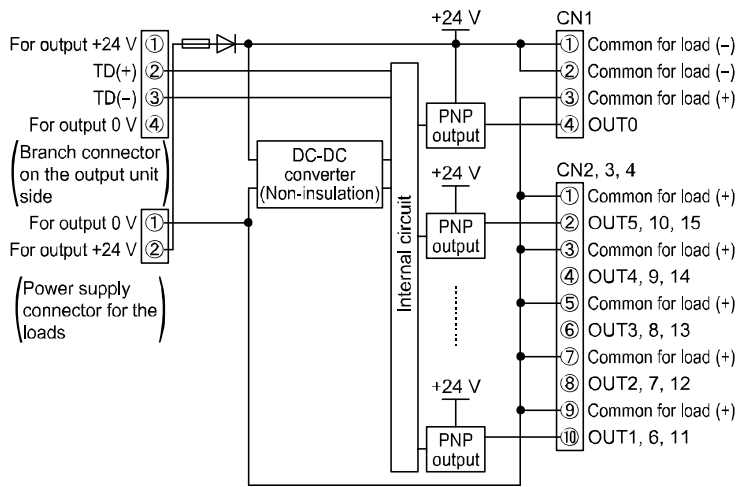

Circuit diagram

Terminal connector (CN1)



No.	Name	Function
CN1		
1	COM	Common for load (+)
2	COM	Common for load (-)
3	COM	Common for load (-)
4	Output	OUT0

Terminal connector (CN2, CN3, CN4)

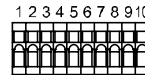

No.	Name	Function		
		CN2	CN3	CN4
1	COM	Common for load (-)		
2	Output	OUT5	OUT10	OUT15
3	COM	Common for load (-)		
4	Output	OUT4	OUT9	OUT14
5	COM	Common for load (-)		
6	Output	OUT3	OUT8	OUT13
7	COM	Common for load (-)		
8	Output	OUT2	OUT7	OUT12
9	COM	Common for load (-)		
10	Output	OUT1	OUT6	OUT11

### •Wiring of the branch cable, and load electric wire and terminal block connector

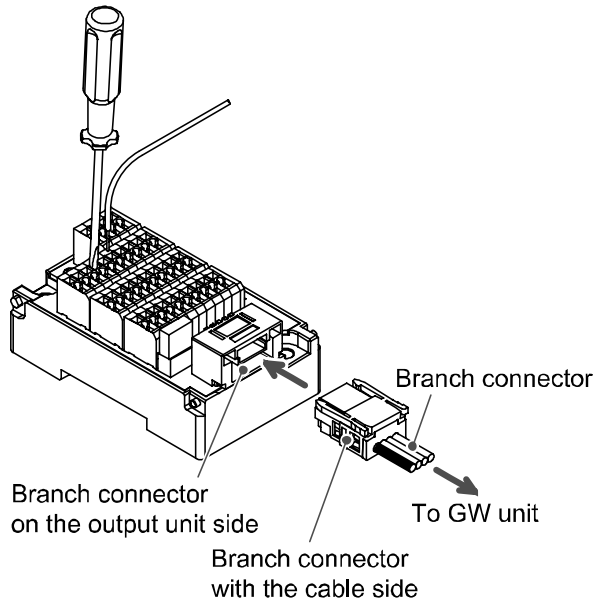

- Insert flat blade watch driver from slots on a terminal block connector to the end position.
- Hold clamping part opened with a blade of the driver.
- Insert electric wire into a clamping unit of a terminal block and pull the driver to finish wiring.
- Applicable electric wire size is 0.08 to 1.5 mm<sup>2</sup> (AWG 16 to 28).
- Wire sheath stripped length is 5 to 6 mm.
- Too long stripped length might expose conductor and cause insulation failure, and too short stripped length might get the sheath caught or make the conductor unclamped or clamped improperly resulting in contact failure or disconnection of electric wire.
- The flat blade watch driver shall have 2.5 mm x 0.4 mm blade end width and hold the clamp opened.

\*: For crimping of a branch connector, refer to page 17.

### The terminal block connector can be connected with the following electric wires.

- Solid wire, fine stranded wire, stranded conductor ultrasonically bonded, stranded conductor with ferrule, stranded conductor with pin terminal.

### Wiring of power supply line and terminal block for external power supply.

- Applicable electric wire size is 0.14 to 1.5 mm<sup>2</sup> (AWG 16 to 26).
- Wire sheath stripped length is 4 to 6 mm.
- Too long stripped length might expose conductor and cause insulation failure, and too short stripped length might get the sheath caught or make the conductor unclamped or clamped improperly resulting in contact failure or disconnection of electric wire.
- The flat blade watch driver shall have 2.5 mm x 0.4 mm blade end width and hold the clamp opened.
- Tightening torque for terminal block: 0.22 Nm at minimum.

### Maximum load current

Internal power supply type (EX510-DYN3, DYP3)

- The following three requirements shall be satisfied: (1) 0.5 A or less per point.  
(2) 1 A or less per unit.  
(3) Total current from OUT0 to 7 and from OUT8 to 15 is 1 A respectively.

Auxiliary power supply type (EX510-DYN4, DYP4)

- The following three requirements shall be satisfied: (1) 0.5 A or less per point.  
(2) 3 A or less per unit.  
(3) Total current from OUT0 to 7 and from OUT8 to 15 is 1.5 A respectively.

For the load to the light, place an in-rush current restriction resistor to prevent potential fusing due to in-rush current.

# Specifications

## ■ Specifications

Model No.	EX510-DYN3	EX510-DYP3	EX510-DYN4	EX510-DYP4
Output type	NPN	PNP	NPN	PNP
Rated load voltage	24 VDC			
Power supply type	Internal power supply (from GW unit)		External power supply (from power supply connector)	
Power supply connector acceptable electric wire	-		0.14 to 1.5 mm <sup>2</sup> (AWG16 to 26)	
Output point	16			
Output connector type	Cage clamp type			
Acceptable electric wire	0.08 to 1.5 mm <sup>2</sup> (AWG16 to 28)			
Max. load current	Meet the three following conditions: (1) 1 point: 0.5 A or less (2) 1 unit: 1 A or less (3) Total current of OUT0 to 7: 1 A or less Total current of OUT8 to 15: 1 A or less		Meet the three following conditions: (1) 1 point: 0.5 A or less (2) 1 unit: 3 A or less (3) Total current of OUT0 to 7: 1.5 A or less Total current of OUT8 to 15: 1.5 A or less	
Enclosure	Short circuit installed			
Current consumption	50 mA or less (Internal unit)			
Weight	130 g (Include accessories)			

### ● Applicable manifold valve series

The Output unit can drive the 2-port valve of VX, VCW, VDW series, etc.

Refer to the catalogs and Operation Manual of each valve series for detail of the solenoid valve and manifold, etc.

## ■ Dimensions

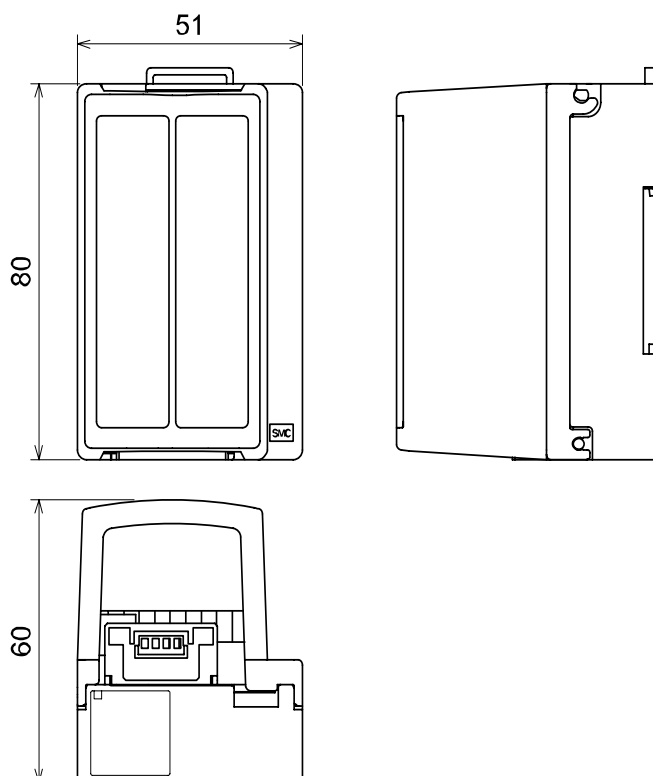

# Input unit

## Summary of Product Parts

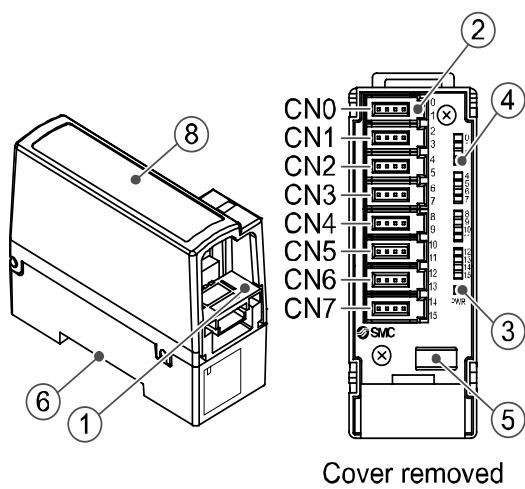

EX510-DX□1

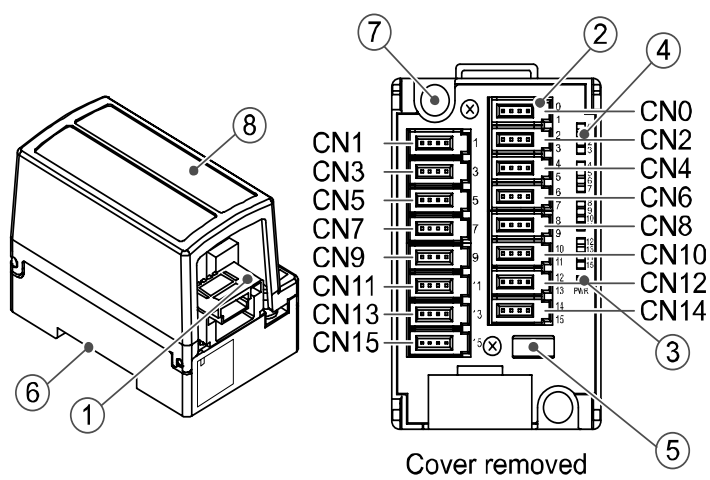

EX510-DX□2

### Accessory

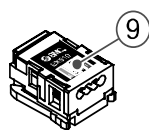

Branch connector  
(2 pcs.) (EX510-LC1)

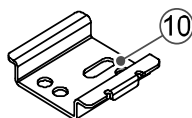

Bracket  
(Attached to EX510-DX□1 only)

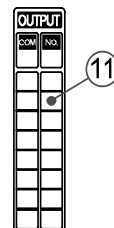

Marker plate

No.	Element	Description
1	Branch connector on the Input unit side	Used to crimp branch connector (⑨) into branch cable (EX510-FC□□) and connected them to GW unit.
2	e-con socket	Used to connects sensor.
3	Power supply LED	Lights up: Power ON (normal) Goes off: Power OFF
4	Display LED	Lights up: Sensor signal input ON Goes off: Sensor signal input OFF
5	Fuse	Fuse is replaceable.
6	Mounting slot	Used for mounting the unit on DIN rail and with attached bracket (⑩) (thread mounting).
7	Mounting hole	Used to mount the unit with two M4 screws. (EX510-DX□ only)
8	Cover	Used to protect sensor cable and provided with marker plate (⑪) on the top.

# Mounting and Installation

## ■ Installation

### ● Mounted by screw

#### ● EX510-DX □ 1

<Mounting example 1>

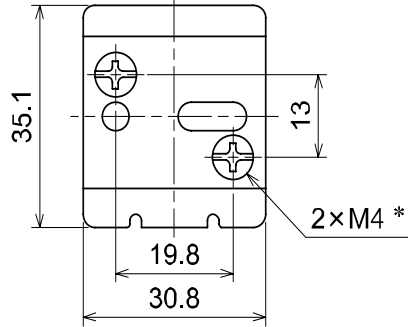

<Mounting example 2>

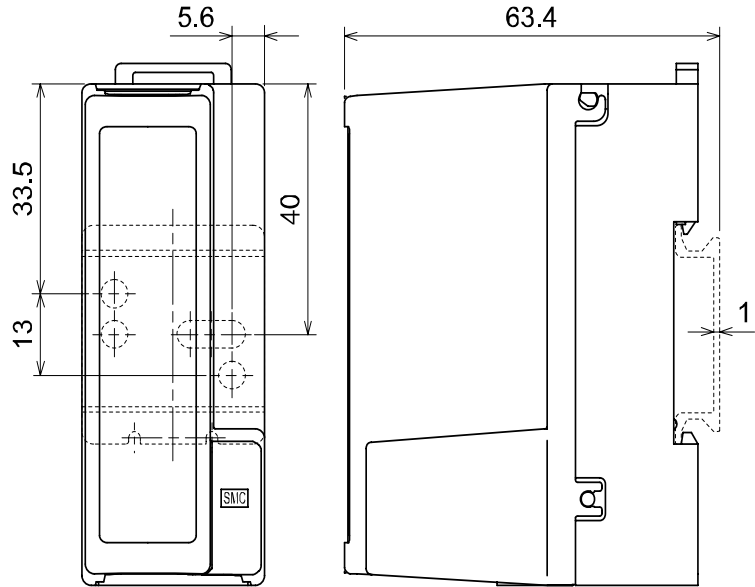
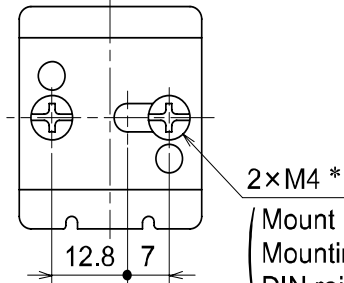

Mount bracket with 2 pieces of M4 screw.  
 Mounting and removal method of bracket are the same as "Mounted on DIN rail" in the next item.

#### ● EX510-DX □ 2

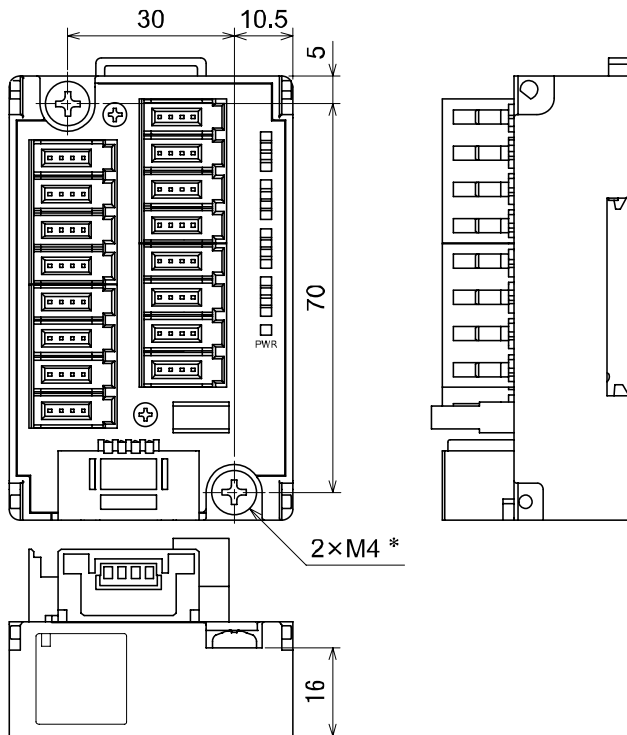

Cover removed (tolerance  $\pm 0.2$  mm)

\*: Tightening torque: 0.8 Nm

•Mounted on DIN rail (Common to EX510-DX 1 and 2)

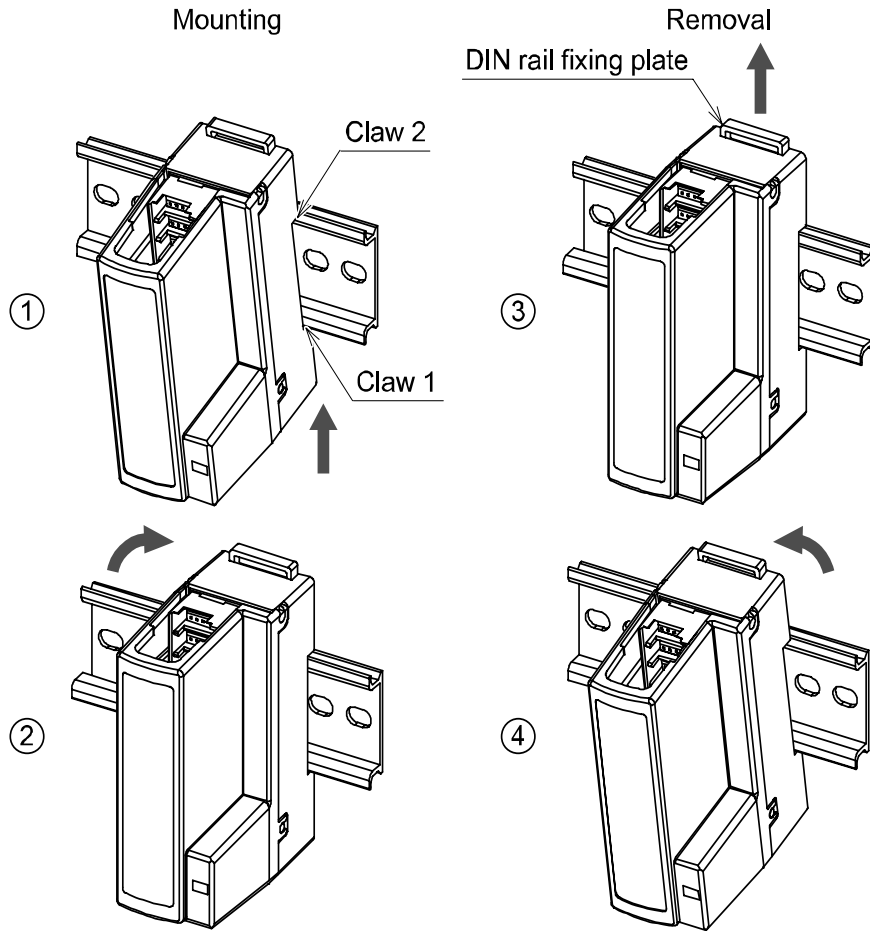

Put claw 1 at the body under DIN rail or bracket and push it upward. Push down claw 2 to the opposite rail until the claw clicks to be set stably. (Mounting procedure ① and ②)  
For removing, push up DIN rail fixing plate at the body with a flat screwdriver, and remove it by tilting Claw 2 side forward. (Removal procedure ③ and ④)

## ■Wiring

### ●Internal circuit and wiring

#### ●EX510-DXB1: Input unit for 2-wire type (1 connector 2-input type)

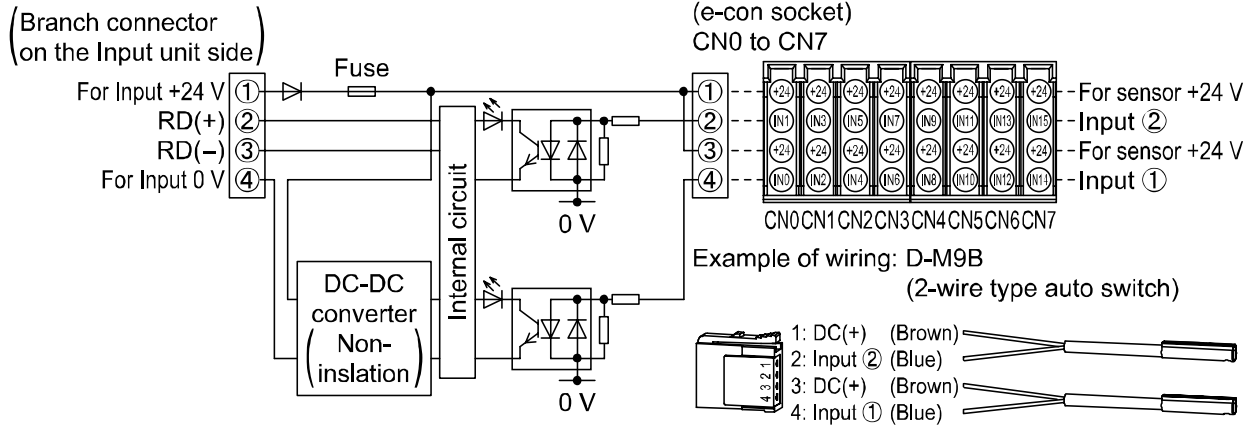

#### ●EX510-DXN1: Input unit for NPN (1 connector 2-input type)

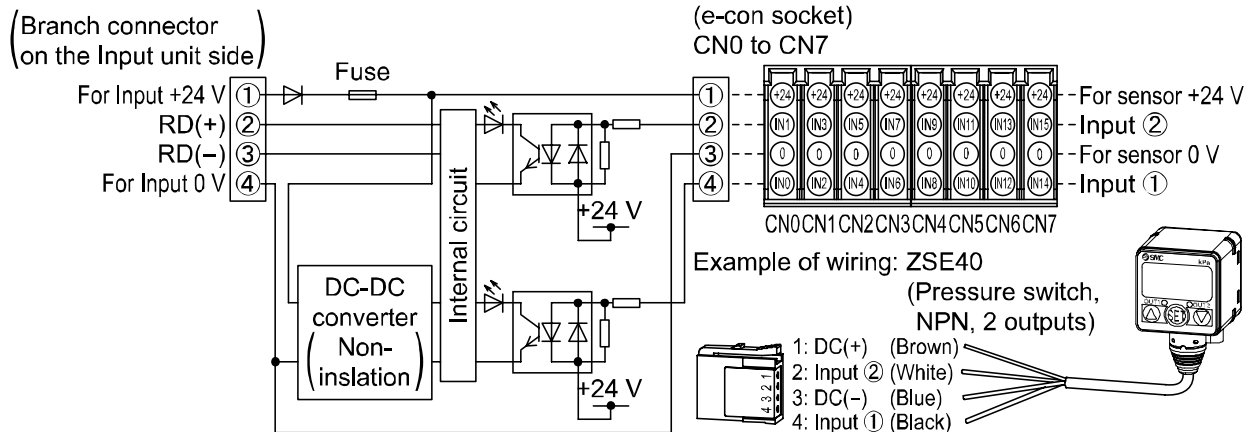

#### ●EX510-DXP1: Input unit for PNP (1 connector 2-input type)

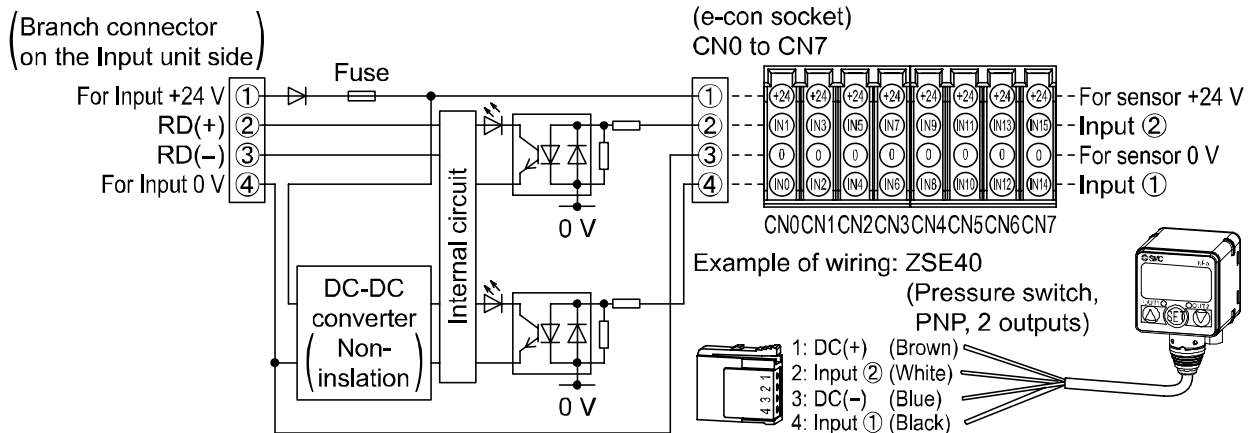

•EX510-DXN2: Input unit for NPN (1 connector 1 input type)

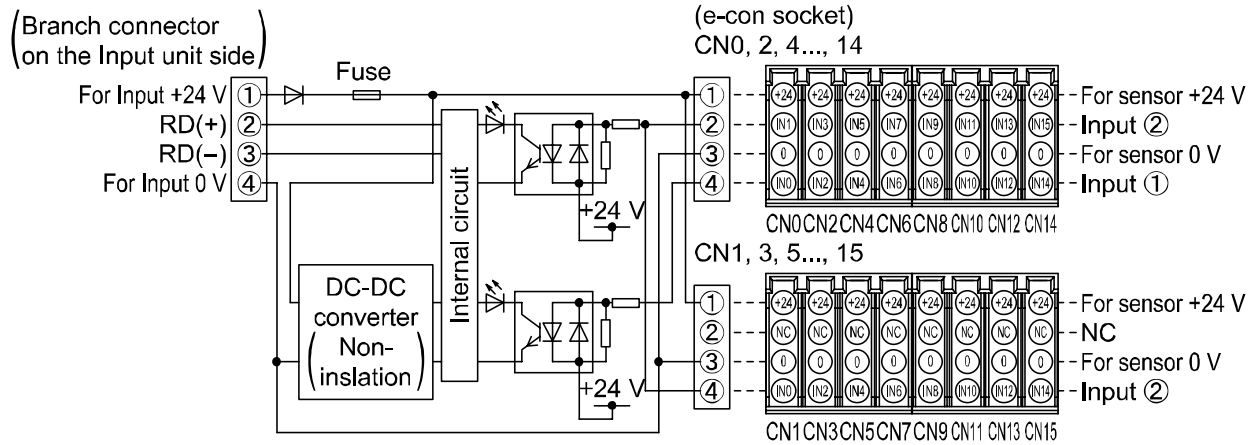

Example of wiring: D-M9N (3-wire type auto switch NPN output)

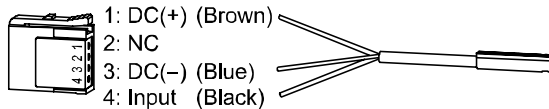

•EX510-DXP2: Input unit for PNP (1 connector 1 input type)

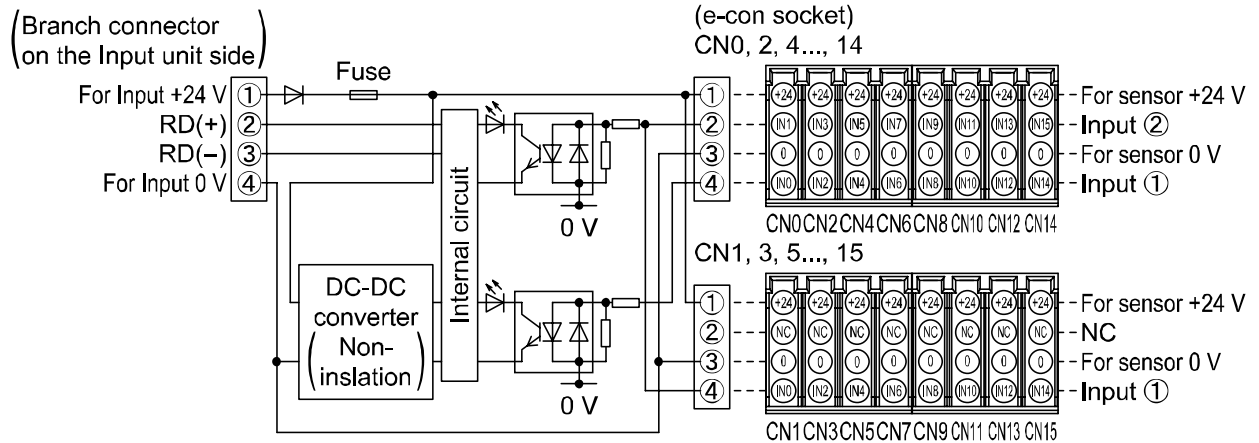

Example of wiring: D-M9P (3-wire type auto switch PNP output)

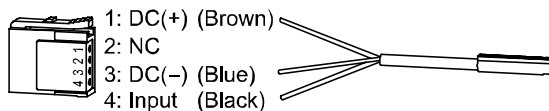

- Wiring of branch cables and e-con
  - Insert the branch connector at cable side into mating connector at Input unit side.
  - Connect e-con after removal of cover.

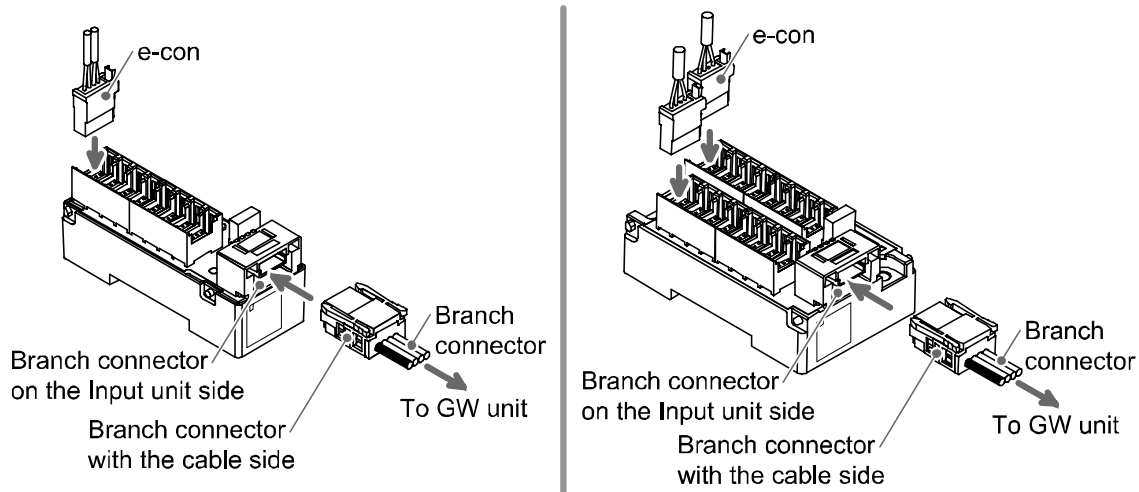

\*: For crimping of a branch connector, refer to page 17.

- Sensor connection
  - Utilize e-con to connect the sensor to the Input unit.
  - Strip the sensor wire as shown in the right figure. (Refer to the table below for correspondence between connector and electrical wire gauge.)

Lead Wire Table

SMC Product No. (1 pc)	Color of cover	Applicable gauge of cable (□)	Nominal sectional area (mm <sup>2</sup> )	Product No.
ZS-28-CA-1	Orange	0.6 to 0.9	0.1 to 0.5 (AWG26 to 20)	3-1473562-4 (AMP)
ZS-28-CA-2	Red	0.9 to 1.0		1-1473562-4 (AMP)
ZS-28-CA-3	Yellow	1.0 to 1.15		1473562-4 (AMP)
ZS-28-CA-4	Blue	1.15 to 1.35		2-1473562-4 (AMP)
ZS-28-CA-5	Green	1.35 to 1.60		4-1473562-4 (AMP)
ZS-28-C	Red	0.8 to 1.0	0.14 to 0.3 (AWG26 to 24)	37104-3101-000FL (Sumitomo 3M)
ZS-28-C-1	Yellow	1.0 to 1.2		37104-3122-000FL (Sumitomo 3M)
-	Transparency	to 1.5 or less	0.08 to 0.5 (AWG28 to 20)	XN2A-1430* (OMRON)

\*: Note: If given tensile force more than 12N, cable may separate from connector.

- Insert the cable to the end with checking correspondence between color of cable and number stamped on e-con. (Refer to page 42 "Internal circuit and wiring")



- It checks that the above-mentioned preparation work has been performed correctly, and "A" part shown in the left figure is pushed by hand and makes temporary connection.
- "A" part's center is straightly pushed in by tools, such as pliers.
- e-con is cannot be reused once crimped for connection. For the connection failure such as incorrect order of wire and incomplete insertion, please use the new e-con for sensor.

# Specifications

## ■ Specifications

Item	Specification		
Model No.	EX510-DXN □	EX510-DXP □	EX510-DXB1
Applicable sensor	NPN output	PNP output	2 wire type
Number of input points	16 points (See diagram below for details.)		
Supply voltage for sensor	24 VDC		
Max. supply current for sensor	0.2 A/1 point, 0.9 A/1 unit		
Current consumption	100 mA or less (inside of Input unit)		
Input resistance	5.6 kΩ		
Rated input current	Approx. 4 mA		
ON voltage/ON current	17 V or more/2.5 mA or more (Between input terminal and +24 V for sensor)	17 V or more/2.5 mA or more (Between input terminal and 0 V for sensor)	
OFF voltage/OFF current	7 V or less/1mA or less (Between input terminal and +24 V for sensor)	7 V or less/1mA or less (Between input terminal and 0 V for sensor)	
LED display	Green LED (lights up during ON time)		
Weight	EX510-DX □ 1: 90 g, EX510-DX □ 2: 110 g (including accessories)		

Derating by input points

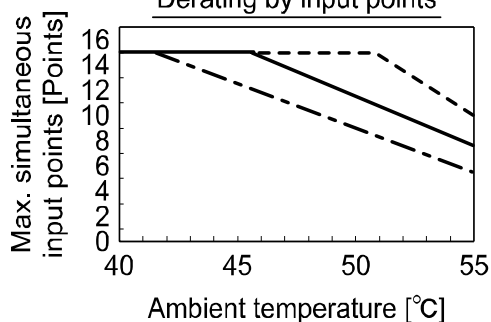

	Voltage for input and controlling part [V]
---	21.6
—	24
- · -	26.4

## ■ Dimensions

### ● EX510-DX □ 1

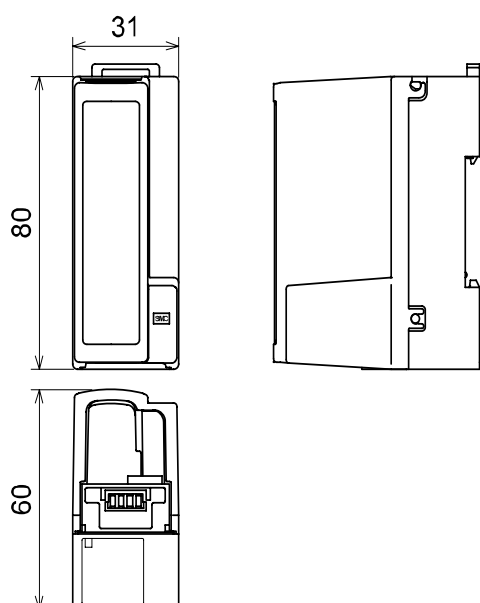

### ● EX510-DX □ 2

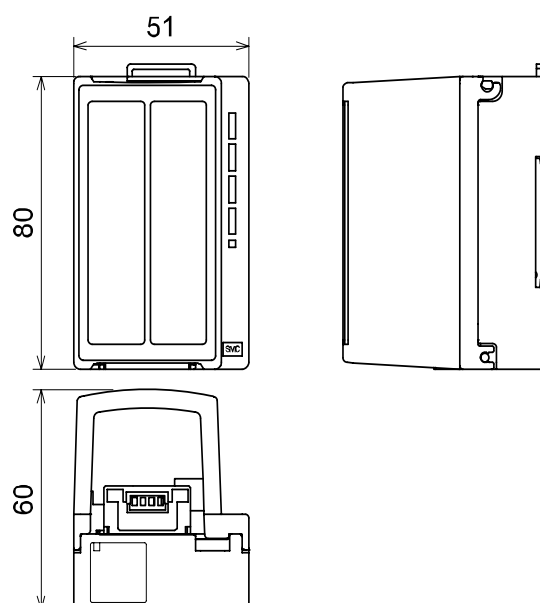

## Maintenance

### •Mounting and wiring conditions

Check items	Condition	Solution
Confirm the connectors of each unit (communication, power supply, input and output) is firmly connected.	No looseness	Give an additional tightening.
Confirm the terminating resistor is connected to both ends of network. (If this system is located at termination of network.)		
Confirm there is no breakage of connecting cable.	No defect on appearance	Replace with a new one if there is a defect found on appearance.

### •Service parts

Check items	Condition	Solution
CC-Link compatible cable for moving parts (if used)	No defect on appearance and conductor resistance	Replace with a new one if there is a defect found on appearance and conductor resistance.
Display and operation	No defect on operating conditions and display	Replace with new unit if there is unintentional operation and defect found on display.

### •Power supply

Check items	Condition	Solution
Measure the voltage at both ends of input and GW controlling part power supply and confirm the voltage is within specifications.	24 VDC $\pm$ 10%	Investigate the cause of fluctuation of the voltage and take measure.
Measure the voltage at both ends of output power supply and confirm the voltage is within specifications.	24 VDC+10%/-5%	Investigate the cause of fluctuation of the voltage and take measure.

### How to reset the product for power cut or forcible de-energizing

Supply power to the product.

The output status just before the power failure is not maintained when power supply is recovered.

Start operation after confirming safety of the entire equipment.

# Troubleshooting

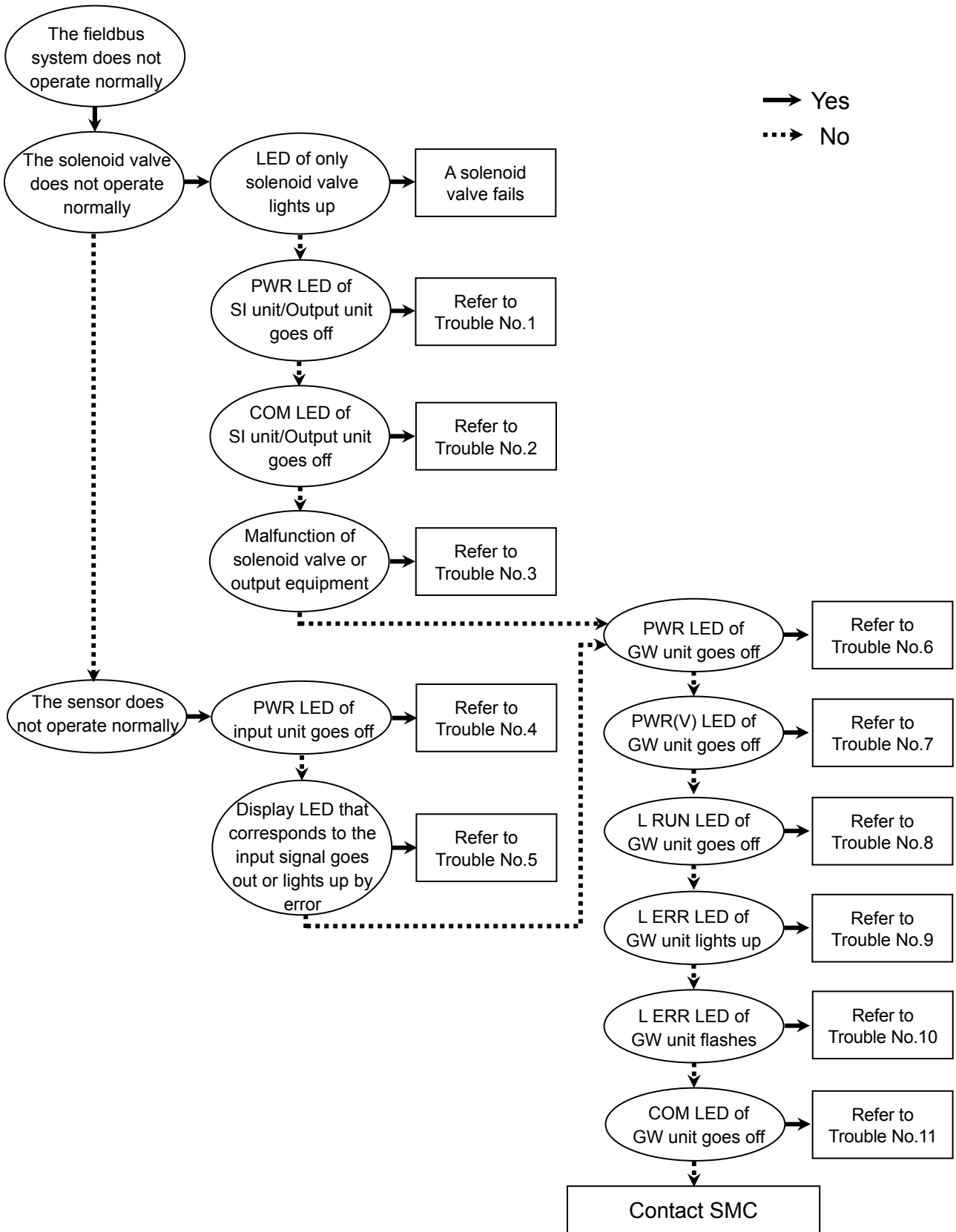

### Trouble No.1

Trouble	Possible cause	Investigation method of cause	Solution
PWR LED of SI unit/Output unit goes off	Incorrect wiring of branch cable	Check that the cable of the branch cable is not broken or mis-connected or loosen at the connection.	Check the branch cable. (Replace the cable if it is broken.)
	Incorrect wiring of power source for output	Check that the power cable for output is correctly wired to the power connector of GW unit or Output unit.	Review the wiring.
	Failure of the power supply for the power for output	Check the power status for output.	Supply 24 VDC+10%/-5% to power source for output of GW unit or Output unit.

### Trouble No.2

Trouble	Possible cause	Investigation method of cause	Solution
COM LED of SI unit/Output unit goes off	Incorrect wiring of branch cable	Check that the cable of the branch cable is not broken or mis-connected or loosen at the connection.	Check the branch cable. (Replace the cable if it is broken.)
	Failure of the branch cable	Check that the power supply line is not in the same route as the power line and/or the high voltage line.	Separate the power supply cable from the power line and/or high voltage line. Supply power to GW unit or the Output unit after separation is confirmed to be completed.
		Check the wire length of the branch cable and if the exclusive cable is used.	Review the wiring of the branch cable.

### Trouble No.3

Trouble	Possible cause	Investigation method of cause	Solution
Malfunction of solenoid valve or Output unit	Incorrect wiring or connection between SI unit/Output unit and solenoid valve/output equipment	Check that the connections of the connectors between SI unit/Output unit and solenoid valve/output equipment are not loosened.	Check the connection between SI unit/Output unit and solenoid valve/output equipment.
		Check that the cables between SI unit/Output and solenoid valve/output equipment is not broken or mis-connected.	Check the connection between SI unit/Output unit and solenoid valve/output equipment. (Replace the cable if it is broken.)
	Abnormal power voltage	Check that the supply power voltage from SI unit/Output unit is within the power supply voltage range, and that the branch cable length and the specified current of the unit are within the specified range.	Supply 24 VDC+10%/-5% to the solenoid valve/power supply for output.
	Malfunction with the solenoid valve or output equipment	Check the troubleshooting of solenoid valve/output equipment.	Check the troubleshooting of solenoid valve/output equipment.
	Malfunction with the solenoid valve or output equipment	Replace the SI unit/Output unit with other one to check if it operates normally.	Replace the SI unit/Output unit.

#### Trouble No.4

Trouble	Possible cause	Investigation method of cause	Solution
PWR LED of the Input unit goes off	Incorrect wiring of the branch cable	Check that the cable of the branch cable is not broken or mis-connected or loosen at the connection.	Check the connection of the branch cable. (Replace the cable if it is broken.)
	Incorrect wiring of power supply to the controller for input and GW	Check that the wiring of the power supply for controller for input and GW to the power supply connector of the GW unit is correctly done.	Review the wiring of the power cable of GW unit.
	Failure of the power supply to the controller for input and GW	Check the power supply status to the controller for input and GW.	Supply 24 VDC±10% to the input of GW unit and power supply to the controller for GW.
	Fuse of the Input unit blows	Check that fuse of the Input unit is not blown.	Eliminate the cause of short-circuit and replace the fuse.
	Malfunction with the Input unit	Replace the Input unit and check if it operates normally.	Replace the Input unit.

#### Trouble No.5

Trouble	Possible cause	Investigation method of cause	Solution
Display LED corresponding to input signal goes off or lights up by error	Inconsistent polarity in sensors	Check that the Input unit specifications (NPN, PNP) and the sensor specifications are consistent.	Make a suitable combination of Input unit and sensor.
	Incorrect connection of the sensor	Check that the sensor cable is not broken and the connection between the sensor cable and the connector is not loosened.	Review the connection of the sensor cable. (Replace the cable if it is broken.)
	Sensor failure	Check the troubleshooting of the sensor.	Check the troubleshooting of the sensor.

#### Trouble No.6

Trouble	Possible cause	Investigation method of cause	Solution
PWR LED of GW unit goes off	Incorrect wiring of the power supply for the input and control	Check that the power supply cable for the input and control is not broken, and that the connection between the power supply cable and connector has not loosened.	Review the connection of the power supply cable. (Replace the cable if it is broken.)
		Check that the wiring of the power supply cable is correctly done.	Review the wiring of the power supply cable.
	Failure of the power supply for the input and control	Check the supply voltage to the power supply for the input and control.	Supply 24 VDC ±10% to the power supply for the input and control.

### Trouble No.7

Trouble	Possible cause	Investigation method of cause	Solution
PWR(V) LED of GW unit goes off	Incorrect wiring of the power supply for output	Check that the cable of the power supply for output is not broken and the connection between the power supply cable and connector is not loosened.	Review the connection of the power supply cable. (Replace the cable if it is broken.)
		Check that the wiring of the power supply cable is correctly done.	Check the wiring of the power supply cable.
	Failure of the power supply for output	Check the supply voltage to the power supply for output.	Supply 24 VDC+10%/-5% to the power supply for output.

### Trouble No.8

Trouble	Possible cause	Investigation method of cause	Solution
L RUN LED of GW unit goes off	Setting error	Check the setting of the address and transmission speed.	Review the setting of switches.
	Communication error	Check the wiring length of the communication line against the communication speed, the existence of the terminal resistance at the both end of the main line, and that the exclusive cable for DeviceNet is used.	Review the wiring.
		Broken communication line	Check that there is no broken communication line or loosened connector.
		Check if the PLC is operating normally.	Review the setting of the PLC.
	Duplicated address	Check that there is no duplicated address.	Review the setting of address.
Failure of GW unit	Replace with a new GW unit and check that normal operation is recovered.	Replace the GW unit with a new one.	

### Trouble No.9

Trouble	Possible cause	Investigation method of cause	Solution
L ERR LED of GW unit lights up	Address setting error	Check the setting of address.	Review the setting of switches.
	Incorrect wiring of communication line	Check that there is no incorrect connection of communication line.	Review the communication line.
	Abnormal status of GW unit	Check that the FG terminal is grounded.	Ground the FG terminal to improve the noise resistance of the fieldbus system.
		Check that the power supply line is not in the same route as the power line and/or high voltage line.	Separate the power supply line from the power line and the high voltage line.

### Trouble No.10

Trouble	Possible cause	Investigation method of cause	Solution
L ERR LED of GW unit flashes	Setting error Abnormal status of GW unit	Check that the setting of the switches of the GW unit has not been changed while the system was being operated normally.	Review the setting of switches.
		Check that the FG terminal is grounded.	Ground the FG terminal to improve the noise resistance of the fieldbus system.
	Abnormal status of GW unit	Check that the power supply line is not in the same route as the power line and/or high voltage line.	Separate the power supply line from the power line and the high voltage line.

### Trouble No.11

Trouble	Possible cause	Investigation method of cause	Solution
COM LED of GW unit goes off	Incorrect wiring of the branch cable	Check that the cable of the branch cable is not broken or mis-connected, and that the connection is not loosened.	Review the connection of the branch cable. (Replace the cable if it is broken.)
	Incomplete connection of the Input unit	Check that the Input unit is connected after the input port.	Check that the Input unit is connected after the input port.
	Incorrect wiring of the power supply for input and control for GW	Check that the wiring of the power supply of input and GW unit control to the power supply connector of the GW unit is correctly made.	Review the wiring of the power supply cable of GW unit.
	Power supply failure of the power for input and control for GW	Check the power supply state of the control for input and GW.	Supply 24VDC±10% to the power supply to control for GW and input of GW.
	Fuse of the Input unit blown	Check that the fuse of the Input unit is not blown.	Replace the fuse.

# Option

## •Branch cable

It is a 4-core flat cable used for connection between each unit.

### EX510-FC 1:0

Cable length [L]

01	1 m
02	2 m
05	5 m
10	10 m
20	20 m
60*	60 m

\*: Cable length of 20 m is available.  
Cut the cable in 20 m or less.

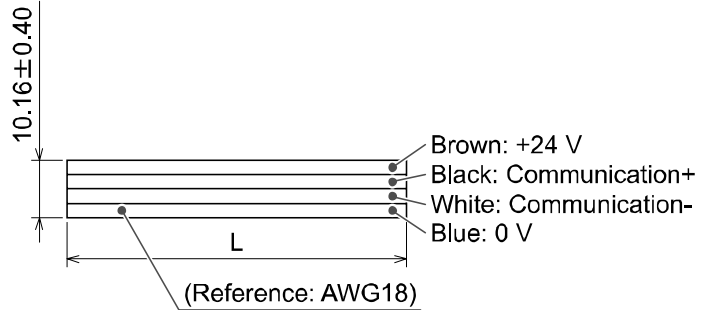

## •Branch connector (Every 1 pc.)

It is a connector used to connect the branch cable to each unit.

SI unit and Input unit are attached with the branch connector for 2 pcs. each.

### EX510-LC1



(When pressure welding)

Electric specification	
Rated voltage	24 VDC
Rated current	Max. 5.0 A
Contact resistance	20 mΩ or less
Withstand voltage	1000 VAC per 1 minute (Leak current 1 mA or less)

## •Cable assembly for output entry

It is a cable assembly to take the remaining output of the SI unit out of it.

### EX510-V S 1:0 S

Output point

S	1 point
W	2 points

Valve connector

Nil	Without valve connector
S	For SY/SYJ
Q	For VQ/VQZ *

\*: The common(+) type of VQ series is only available.

Cable length [L]

10	1.0 m
30	3.0 m

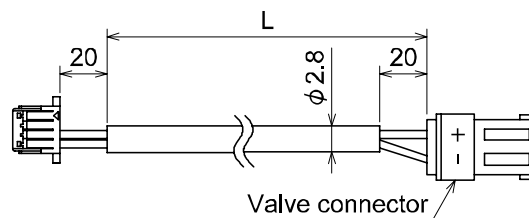

•e-con

It is a connector used for connecting a sensor to the Input unit (EX510-DX□□).

Refer to "Sensor connection" on page 47 for the connector part number and the applicable electric wire size.

ZS-28-C□-□

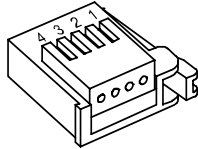

•Fuse for replacement

It is a fuse for replacement used for Input unit(EX510-DX□□) and Output(EX510-DY□□) unit.

EX9-FU 1:0

•Object model No.

10	1 A
50	5 A

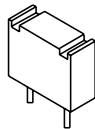

Electric specification		
Model no.	EX9-FU10	EX9-FU50
Applicable model	EX510-DX□□ EX510-DY□3	EX510-DY□4
Rated current	1 A	5 A
Rated insulation capacity	48 VAC/DC 50 A	
Fuse resistance value	0.145 Ω	18 mΩ

#### Revision history

- A: Correct words.
- B: Add the explanation of the setting method for each function.  
Correct words.
- C: Add the contents.
- D: Revision.
- E: Modified errors in text.

## SMC Corporation

4-14-1, Sotokanda, Chiyoda-ku, Tokyo 101-0021 JAPAN

Tel: +81 3 5207 8249 Fax: +81 3 5298 5362

URL <http://www.smcworld.com>

---

Note: Specifications are subject to change without prior notice and any obligation on the part of the manufacturer.  
© 2009-2011 SMC Corporation All Rights Reserved

