



# Operation Manual

## PRODUCT NAME

Fieldbus system  
DeviceNet™ compatible SI unit

## MODEL / Series / Product Number

*EX600-SDN#A*  
*EX600-ED#*

**SMC Corporation**

## Table of Contents



Safety Instructions	3
System Outline	9
Definition and terminology	10
Assembly	12
Mounting and Installation	15
Installation	15
Wiring	17
<b>SI Unit</b>	
Model Indication and How to Order	18
Names and Functions of Product	18
Mounting and Installation	19
Wiring	19
Setting and Adjustment	20
LED Display	25
Specification	27
Specifications	27
Dimensions	28
<b>Endplate</b>	
Model Indication and How to Order	29
Names and Functions of Product	29
Mounting and Installation	30
Wiring	30
Specification	31
Specifications	31
Dimensions	31

Maintenance	33
Troubleshooting	34
Parameter Setting	43
Parameter definition and setting	43
Hardware Configuration	56
ESD file and icon	56
Setting using RSNetWorx for DeviceNet™	57
I/O Map	61
Diagnostic	62
Details of diagnostic data	65
DeviceNet™ Object	67
Accessories	79

## Safety Instructions

These safety instructions are intended to prevent hazardous situations and/or equipment damage. These instructions indicate the level of potential hazard with the labels of "Caution", "Warning" or "Danger". They are all important notes for safety and must be followed in addition to International standards (ISO/IEC) \*1) and other safety regulations.

- \*1) ISO 4414: Pneumatic fluid power -- General rules relating to systems
- ISO 4413: Hydraulic fluid power -- General rules relating to systems
- IEC 60204-1: Safety of machinery -- Electrical equipment of machines (Part 1: General requirements)
- ISO 10218-1992: Manipulating industrial robots -Safety.
- etc.

-  **Caution** : CAUTION indicates a hazard with a low level of risk which, if not avoided, could result in minor or moderate injury.
-  **Warning** : WARNING indicates a hazard with a medium level of risk which, if not avoided, could result in death or serious injury.
-  **Danger** : DANGER indicates a hazard with a high level of risk which, if not avoided, will result in death or serious injury.

### Warning

- 1. The compatibility of the product is the responsibility of the person who designs the equipment or decides its specifications.**

Since the product specified here is used under various operating conditions, its compatibility with specific equipment must be decided by the person who designs the equipment or decides its specifications based on necessary analysis and test results. The expected performance and safety assurance of the equipment will be the responsibility of the person who has determined its compatibility with the product. This person should also continuously review all specifications of the product referring to its latest catalog information, with a view to giving due consideration to any possibility of equipment failure when configuring the equipment.
- 2. Only personnel with appropriate training should operate machinery and equipment.**

The product specified here may become unsafe if handled incorrectly. The assembly, operation and maintenance of machines or equipment including our products must be performed by an operator who is appropriately trained and experienced.
- 3. Do not service or attempt to remove product and machinery/equipment until safety is confirmed.**
  1. The inspection and maintenance of machinery/equipment should only be performed after measures to prevent falling or runaway of the driven objects have been confirmed.
  2. When the product is to be removed, confirm that the safety measures as mentioned above are implemented and the power from any appropriate source is cut, and read and understand the specific product precautions of all relevant products carefully.
  3. Before machinery/equipment is restarted, take measures to prevent unexpected operation and malfunction.
- 4. Contact SMC beforehand and take special consideration of safety measures if the product is to be used in any of the following conditions.**
  1. Conditions and environments outside of the given specifications, or use outdoors or in a place exposed to direct sunlight.
  2. Installation on equipment in conjunction with atomic energy, railways, air navigation, space, shipping, vehicles, military, medical treatment, combustion and recreation, or equipment in contact with food and beverages, emergency stop circuits, clutch and brake circuits in press applications, safety equipment or other applications unsuitable for the standard specifications described in the product catalog.
  3. An application which could have negative effects on people, property, or animals requiring special safety analysis.
  4. Use in an interlock circuit, which requires the provision of double interlock for possible failure by using a mechanical protective function, and periodical checks to confirm proper operation.

## **Caution**

### **The product is provided for use in manufacturing industries.**

The product herein described is basically provided for peaceful use in manufacturing industries. If considering using the product in other industries, consult SMC beforehand and exchange specifications or a contract if necessary.  
If anything is unclear, contact your nearest sales branch.

## **Limited warranty and Disclaimer/Compliance Requirements**

The product used is subject to the following "Limited warranty and Disclaimer" and "Compliance Requirements".

Read and accept them before using the product.

### **Limited warranty and Disclaimer**

1. The warranty period of the product is 1 year in service or 1.5 years after the product is delivered. \*2)  
Also, the product may have specified durability, running distance or replacement parts. Please consult your nearest sales branch.
2. For any failure or damage reported within the warranty period which is clearly our responsibility, a replacement product or necessary parts will be provided.  
This limited warranty applies only to our product independently, and not to any other damage incurred due to the failure of the product.
3. Prior to using SMC products, please read and understand the warranty terms and disclaimers noted in the specified catalog for the particular products.

\*2) Vacuum pads are excluded from this 1 year warranty.

A vacuum pad is a consumable part, so it is warranted for a year after it is delivered.

Also, even within the warranty period, the wear of a product due to the use of the vacuum pad or failure due to the deterioration of rubber material are not covered by the limited warranty.

### **Compliance Requirements**

1. The use of SMC products with production equipment for the manufacture of weapons of mass destruction (WMD) or any other weapon is strictly prohibited.
2. The exports of SMC products or technology from one country to another are governed by the relevant security laws and regulation of the countries involved in the transaction. Prior to the shipment of a SMC product to another country, assure that all local rules governing that export are known and followed.

## Operator

- ◆ This operation manual is intended for those who have knowledge of machinery using pneumatic equipment, and have sufficient knowledge of assembly, operation and maintenance of such equipment. Only those persons are allowed to perform assembly, operation and maintenance.
- ◆ Read and understand this operation manual carefully before assembling, operating or providing maintenance to the product.

### ■ Precautions

#### **Warning**

- Do not disassemble, modify (including changing the printed circuit board) or repair.  
An injury or failure can result.
- Do not operate or set with wet hands.  
This may lead to an electric shock.
- Do not operate the product outside of the specifications.  
Do not use for flammable or harmful fluids.  
Fire, malfunction, or damage to the product can result.  
Verify the specifications before use.
- Do not operate in an atmosphere containing flammable or explosive gases.  
Fire or an explosion can result.  
This product is not designed to be explosion proof.
- If using the product in an interlocking circuit:
  - Provide a double interlocking system, for example a mechanical system.
  - Check the product regularly for proper operation.Otherwise malfunction can result, causing an accident.
- The following instructions must be followed during maintenance:
  - Turn off the power supply.
  - Stop the air supply, exhaust the residual pressure and verify that the air is released before performing maintenance.Otherwise an injury can result.

## **Caution**

- When handling, assembling or replacing the units:
  - Avoid touching any sharp metal parts of the connectors for connecting units.
  - When assembling units, take care not to get any fingers caught between units.  
Injury can result.
  - When disassembling units, take care to avoid excessive force.  
The connection parts of the unit are firmly joined with seals and injury can result.
- After maintenance is complete, perform appropriate functional inspections.  
Stop operation if the equipment does not function properly.  
Safety cannot be assured in the case of unexpected malfunction.
- Provide grounding to assure the safety and noise resistance of the Fieldbus system.  
Individual grounding should be provided close to the product with a short cable.

### ■ NOTE

- Follow the instructions given below when designing, selecting and handling the product.
- The instructions on design and selection (installation, wiring, environment, adjustment, operation, maintenance, etc.) described below must also be followed.
- \*Product specifications
  - The direct current power supply to combine should be UL 1310 Class2 power supply when conformity to UL is necessary.
  - Use the specified voltage.  
Otherwise failure or malfunction can result.
  - The power supply for the unit should be 0V as the standard for both the power supply for outputs and the power supply for inputs and control.

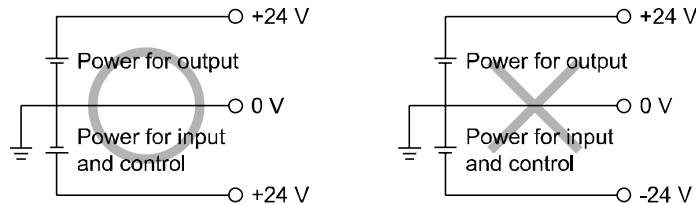

- Reserve a space for maintenance.  
Allow sufficient space for maintenance when designing the system.
- Do not remove any nameplates or labels.  
This can lead to incorrect maintenance, or misreading of the operation manual, which could cause damage or malfunction to the product.  
It may also result in non-conformity to safety standards.
- Beware of inrush current when the power supply is turned on.  
Some connected loads can apply an initial charge current which will activate the over current protection function, causing the unit to malfunction.

## ●Product handling

### \*Installation

- Do not drop, hit or apply excessive shock to the SI unit.  
Otherwise damage to the product can result, causing malfunction.
- Tighten to the specified tightening torque.  
If the tightening torque is exceeded the mounting screws may be broken.  
IP67 protection cannot be guaranteed if the screws are not tightened to the specified torque.
- If a large manifold valve is mounted, lift the unit so that stress is not applied to the connecting part while transporting.  
The stress may cause breakage of the connecting part. The unit may become very heavy depending on the combination. Transportation/installation shall be performed by multiple operators.
- Never mount a product in a location that will be used as a foothold.  
The product may be damaged if excessive force is applied by stepping or climbing onto it.

### \*Wiring

- Avoid repeatedly bending or stretching the cables, or placing heavy load on them.  
Repetitive bending stress or tensile stress can cause breakage of the cable.
- Wire correctly.  
Incorrect wiring can break the product.
- Do not perform wiring while the power is on.  
Otherwise damage to the SI unit and/or input or output device can result, causing malfunction.
- Do not route wires and cables together with power or high voltage cables.  
Otherwise the SI unit and/or input or output device can malfunction due to interference of noise and surge voltage from power and high voltage cables to the signal line.  
Route the wires (piping) of the SI unit and/or input or output device separately from power or high voltage cables.
- Confirm proper insulation of wiring.  
Poor insulation (interference from another circuit, poor insulation between terminals, etc.) can lead to excess voltage or current being applied to the product, causing damage.
- Take appropriate measures against noise, such as using a noise filter, when the Fieldbus system is incorporated into equipment.  
Otherwise noise can cause malfunction.

### \*Environment

- Select the proper type of protection according to the environment of operation.  
IP67 protection is achieved when the following conditions are met.
  - (1)The units are connected properly with fieldbus cable with M12 connector and power cable with M12 (M8) connector.
  - (2)Suitable mounting of each unit and manifold valve.
  - (3)Be sure to fit a waterproof cap on any unused connectors.  
If using in an environment that is exposed to water splashes, please take measures such as using a cover.  
Do not use in an environment where moisture or water vapor are present. Otherwise failure and malfunction can result.
- Do not use in a place where the product could be splashed by oil or chemicals.  
If the product is to be used in an environment containing oils or chemicals such as coolant or cleaning solvent, even for a short time, it may be adversely affected (damage, malfunction etc.).
- Do not use the product in an environment where corrosive gases or fluids could be splashed.  
Otherwise damage to the product and malfunction can result.
- Do not use in an area where surges are generated.  
If there is equipment generating large surge near the unit (magnetic type lifter, high frequency inductive furnace, welding machine, motor, etc.), this can cause deterioration of the internal circuitry element of the unit or result in damage. Take measures against the surge sources, and prevent the lines from coming into close contact.

- When a surge-generating load such as a relay, valve or lamp is driven directly, use a product with a built-in surge absorbing element.  
Direct drive of a load generating surge voltage can damage the unit.
- The product is CE marked, but not immune to lightning strikes. Take measures against lightning strikes in the system.
- Prevent foreign matter such as dust or wire debris from getting inside the product.
- Mount the product in a place that is not exposed to vibration or impact.  
Otherwise failure or malfunction can result.
- Do not use the product in an environment that is exposed to temperature cycle.  
Heat cycles other than ordinary changes in temperature can adversely affect the inside of the product.
- Do not expose the product to direct sunlight.  
If using in a location directly exposed to sunlight, shade the product from the sunlight.  
Otherwise failure or malfunction can result.
- Keep within the specified ambient temperature range.  
Otherwise malfunction can result.
- Do not operate close to a heat source, or in a location exposed to radiant heat.  
Otherwise malfunction can result.

**\*Adjustment and Operation**

- Set the switches by using a sharp-pointed screwdriver etc. When setting the switch, do not touch other unrelated parts.  
This can cause parts damage or malfunction due to a short circuit.
- Perform settings suitable for the operating conditions.  
Incorrect setting can cause operation failure.  
For details of each setting, refer to page 20 to 24 of this manual.
- Please refer to the PLC manufacturer's manual etc. for details of programming and addresses.  
For the PLC protocol and programming refer to the relevant manufacturer's documentation.

**\*Maintenance**

- Turn off the power supply, stop the supplied air, exhaust the residual pressure and verify the release of air before performing maintenance.  
There is a risk of unexpected malfunction.
- Perform regular maintenance and inspections.  
There is a risk of unexpected malfunction.
- After maintenance is complete, perform appropriate functional inspections.  
Stop operation if the equipment does not function properly.  
Otherwise safety is not assured due to an unexpected malfunction or incorrect operation.
- Do not use solvents such as benzene, thinner etc. to clean each unit.  
They could damage the surface of the body and erase the markings on the body.  
Use a soft cloth to remove stains.  
For heavy stains, use a cloth soaked with diluted neutral detergent and fully squeezed, then wipe up the stains again with a dry cloth.

## System Outline

### •System configuration

The EX600 range of units can be connected to various types of Fieldbus to realize the reduction of input or output device wiring and the distributed control system. The unit communicates with the Fieldbus through the SI unit. One SI unit can be connected with manifold valves with up to 32 outputs and the input • output • I/O units with maximum 10 units.

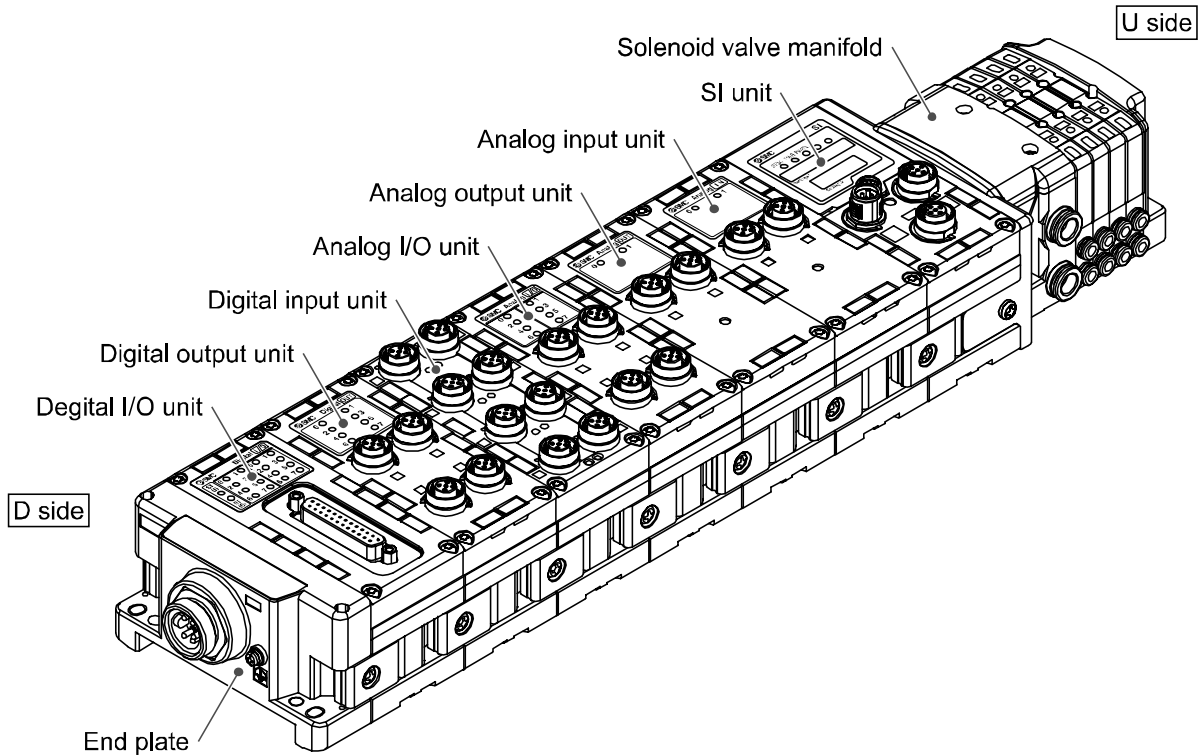

SI unit: Performs Fieldbus communication and solenoid valve manifold ON/OFF output.

Digital input unit: For connecting sensors with switch output capability. PNP and NPN types are available.

Digital output unit: For connecting output device such as solenoid valves, lamps, buzzers, etc. PNP and NPN types are available.

Digital I/O unit: This unit has both digital input and output functions. PNP and NPN types are available.

Analog input unit: For connecting sensors with analog output capability.

Analog output unit: This can be connected to the equipment which can read analog input.

Analog I/O unit: This unit has both analog input and output functions.

End plate: Connected at EX600 Manifold's D side, incorporating the power supply connection.

Solenoid valve manifold: An assembly of solenoid valves. One connector is used as the electric connection to all connected valves.

## ■ Definition and terminology

	Terminology	Definition
A	Address (Station Address)	A number assigned to identify the unit connected onto the DeviceNet™ network. It must not be duplicated.
	AD value	The signal from the analog input device is converted to digital, and displayed in decimal and hexadecimal. These hexadecimal and decimal values are also outputted to the analog output device.
C	Communication speed	The speed at which the fieldbus sends and receives data. It depends on higher-level equipment (PLC, etc.) and is measured in bps (Bits per second).
	Current consumption	The current necessary to operate each unit.
D	DIN rail	A metal rail conforming with DIN (German) standard.
	D Side	The side connected to the end plate when the product is connected to a manifold.
E	EDS	Settable attribute information of a device (each parameter's object address, etc.) stored on external disk.
	Enclosure (IP□□)	Abbreviation of international (ingress) protection. A standard related to the protection from external objects (hands, steel ball, steel wire, dust, water, etc.) applied to the product.
F	FE	Abbreviation of functional earth.
	Fieldbus	The protocol that uses digital communication to exchange signals between field equipment (instruments and actuators) running on site and a PLC.
H	Handheld Terminal (H.T.)	Connected to the dedicated connector of the SI unit to adjust the internal parameters, monitor the status of all input and output signals, and turn on input and output forcibly.
I	Idle	Expression for PLC operation state. For details, Refer to manuals of each PLC maker. Depending on which PLC is used; the idle state might not be available.
M	Manifold	A form consisting of multiple components. A form made by combining multiple components
	MAC ID	Abbreviation for Media-Access-Control Identifier. Node addresses identifier for the DeviceNet™.
N	NPN input	Takes the sensor output that uses the NPN transistor to the signal output line.
	NPN output	The output type that uses an NPN transistor to operate output device. It is also known as a positive common type since a positive potential is applied to the power supply line.
	Number of inputs	The number of points that can receive information from input device (sensor, switch, etc.).
	Number of outputs	The number of points that can operate output device (solenoid valve, light, motor, etc.).
O	Open circuit detection	A diagnosis function to detect if the input or output device wiring is disconnected.

	Terminology	Definition
P	PLC	Abbreviation of programmable logic controller. A digital computer used for automation of electromechanical processes.
	PNP input	Takes the sensor output that uses the PNP transistor to the signal output part.
	PNP output	The output type that uses a PNP transistor to operate output device. It is also known as a negative common type since a negative potential is applied to the power supply line.
S	Short circuit detection	A diagnosis function to detect an over current due to the short circuit of the output and/or power supply positive line with respect to the GND line.
	Short circuit protection	A function to protect the internal circuit from being broken by an over current due to the short circuit of the output and/or power supply positive line with respect to the GND line.
	SI unit	Abbreviation of serial interface unit. A unit connected to a PLC to communicate input and output data.
T	Terminal resistor	A resistor mounted at either end of the fieldbus network.
U	U Side	The side connected to the solenoid valve when the product is connected to a manifold.

# Assembly

## •Precautions before mounting

The units that can be connected vary depending on the SI unit product number.  
Check the applicable unit type before mounting the unit.

Units that can be assembled			Product number of the SI unit	
			EX600-SDN□	EX600-SDN□A
Product number	Digital input unit	EX600-DX□B	○	○
		EX600-DX□C□	○	○
		EX600-DX□D	○	○
		EX600-DX□E	×	○
		EX600-DX□F	×	○
	Disital output unit	EX600-DY□B	○	○
		EX600-DY□E	×	○
		EX600-DY□F	×	○
	Digital I/O unit	EX600-DM□E	×	○
		EX600-DM□F	×	○
	Analog input unit	EX600-AXA	○	○
	Analog output unit	EX600-AYA	×	○
	Analog I/O unit	EX600-AMB	×	○
	Handheld Terminal	EX600-HT1	○	○ *1
EX600-HT1A		○	○	

\*1: EX600-HT1 cannot recognize EX600-D□□E, EX600-D□□F, Ex600-AYA and EX600-AMB.

Find the product number of the SI unit referring to the label shown in the figure below.

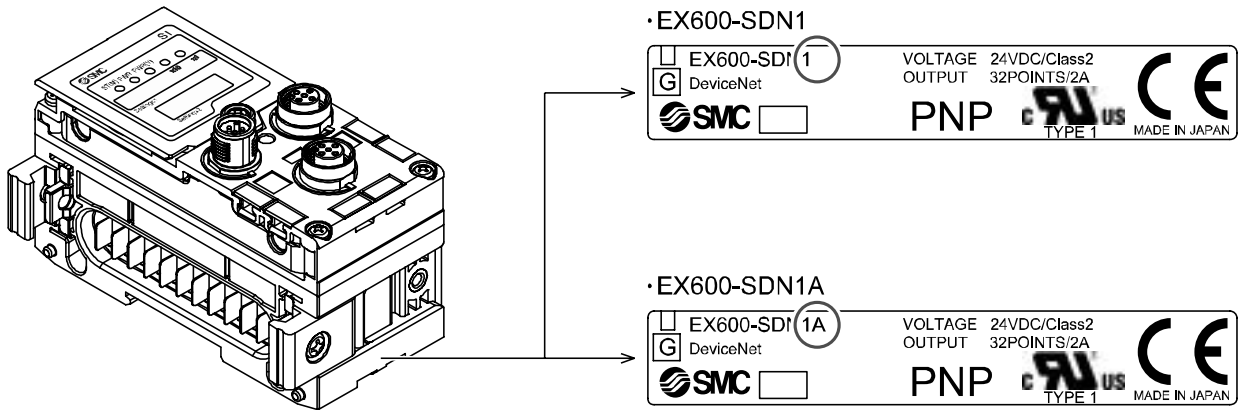

•Assembling the unit as a manifold

\*: If the unit was purchased as a manifold, the work described in this section is not necessary.

(1)Connect a unit to the end plate.

Digital and Analog I/O units can be connected in any order.

Tighten the joint brackets to a torque of 1.5 to 1.6 Nm.

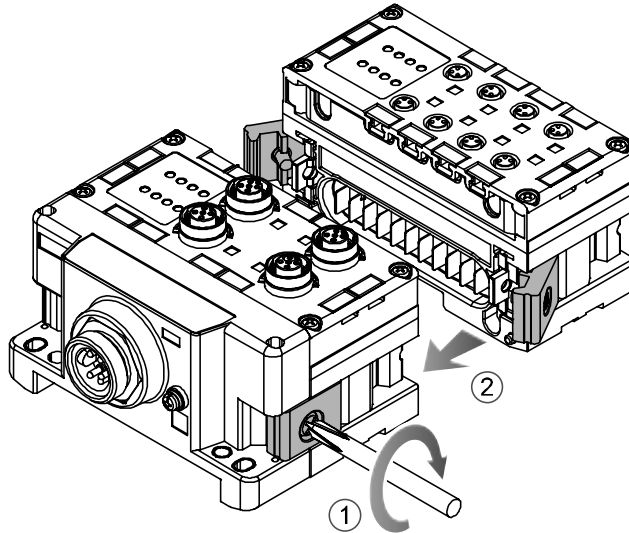

(2)Add more I/O units.

Up to 10 units (including the SI unit) can be connected to one manifold.

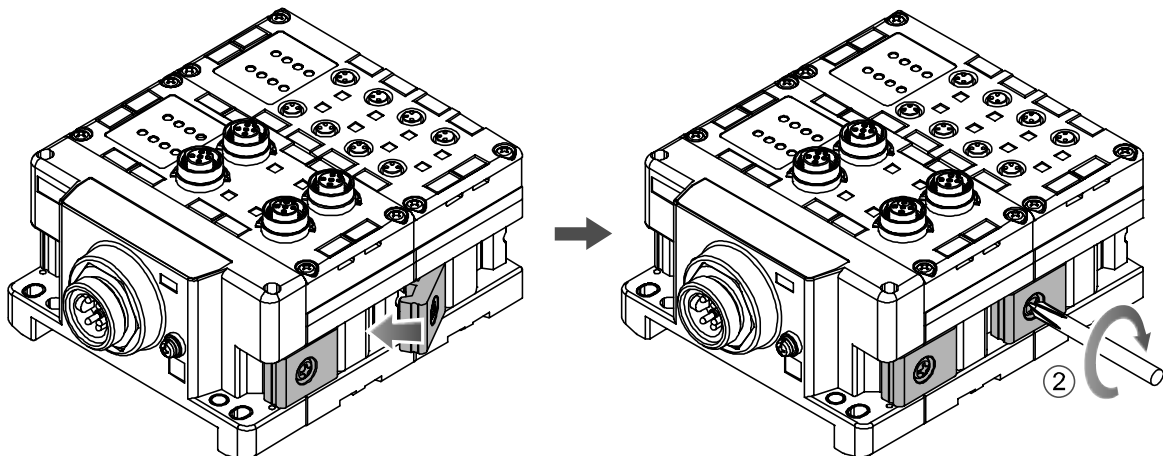

(3)Connecting the SI unit.

After connecting the required I/O units, connect the SI unit.

The method is as above in (1), (2).

(4) Mounting the valve plate.

Mount the valve plate (EX600-ZMV□) to the valve manifold using the valve set screws. (M3x8)  
Apply 0.6 to 0.7 Nm tightening torque to the screws.

┆	Screw mounting place	┆	
┆	SV	: 2 places	┆
┆	S0700	: 2 places	┆
┆	VQC1000	: 2 places	┆
┆	VQC2000	: 3 places	┆
┆	VQC4000	: 4 places	┆
┆	SY	: 2 places	┆

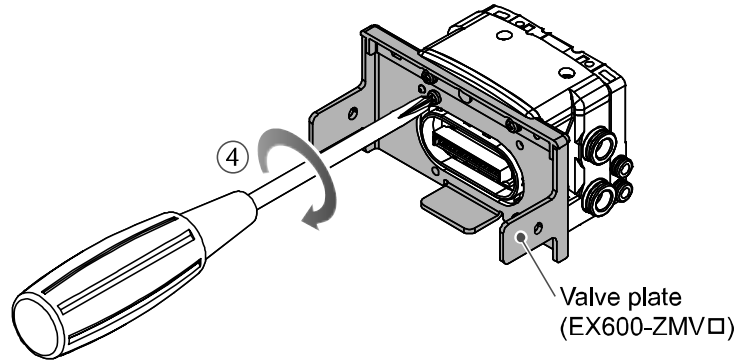

(5) Connect the SI unit to the valve manifold.

Insert the valve plate into the valve plate mounting groove on the side of the SI unit.  
Fix using the valve plate screws (M4x6) supplied, to torque of 0.7 to 0.8 Nm.

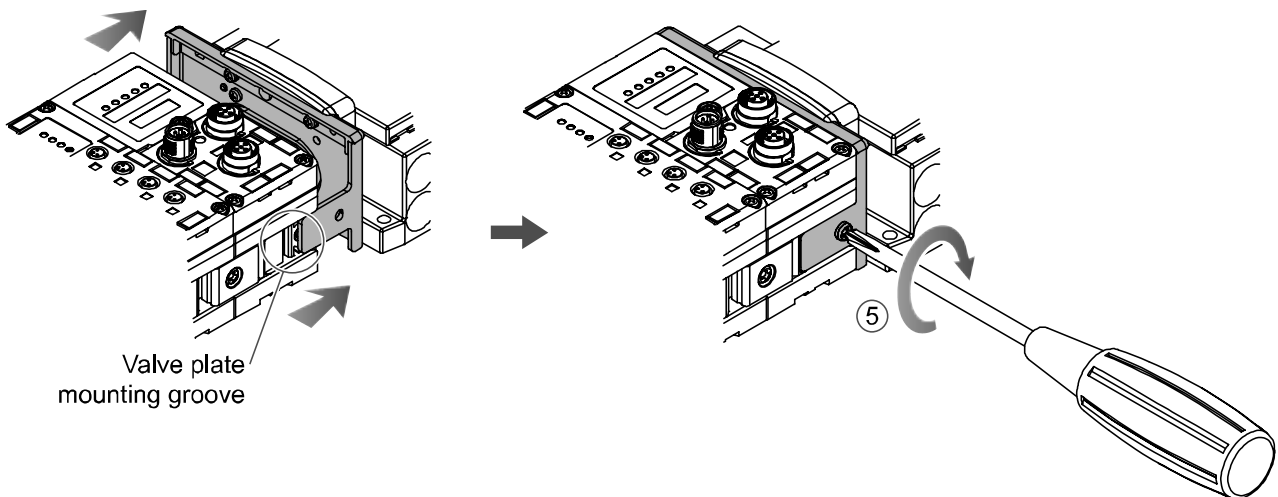

● Precautions for handling

- Please do not connect the unit while the power supply is active. It will cause equipment damage.
- Take care not to drop the nuts of Joint bracket.

# Mounting and Installation

## ■ Installation

### • Direct mounting

(1) When joining six or more units, fix the middle part of the complete EX600 unit with an intermediate reinforcing brace (EX600-ZMB1) before mounting, using 2-M4x5 screws.

Tightening torque: 0.7 to 0.8 Nm.

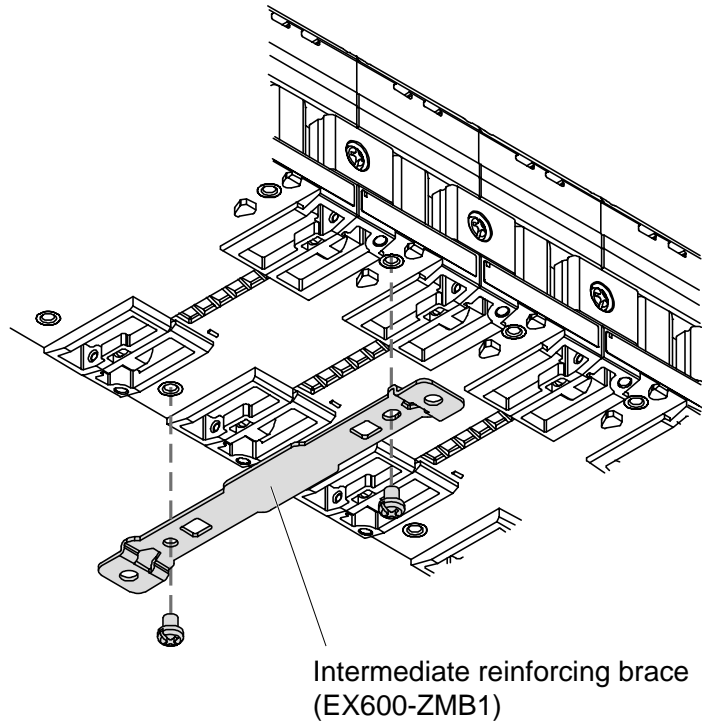

(2) Mount and tighten the end plate at one end of the unit. (M4)

Tightening torque: 0.7 to 0.8 Nm.

Fix the end plate at the valve side while referring to the operation manual of the corresponding valve manifold.

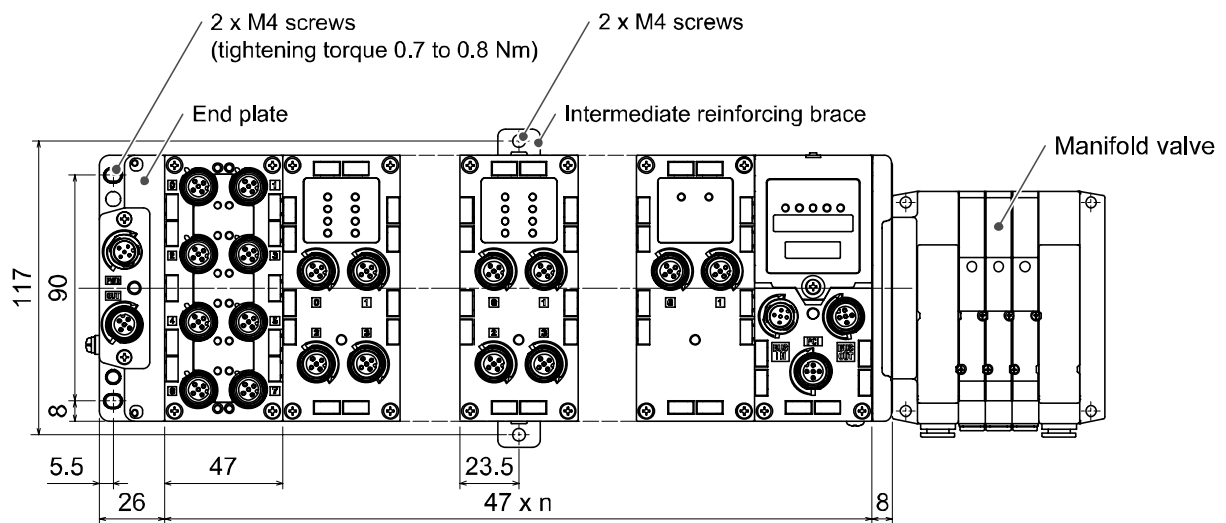

n (Number of connected units)  $\leq 10$

•DIN rail mounting

(Not available for SY series valves. Refer to the SY catalog.)

(1)When joining six or more units, fix the middle part of the complete EX600 unit with an intermediate reinforcing brace (EX600-ZMB2) before mounting, using 2-M4x6 screws.

Tightening torque: 0.7 to 0.8 Nm.

(2)Mount the end plate bracket (EX600-ZMA2) to the end plate at the opposite end to the valves, using 2-M4x14 screws.

Tightening torque: 0.7 to 0.8 Nm.

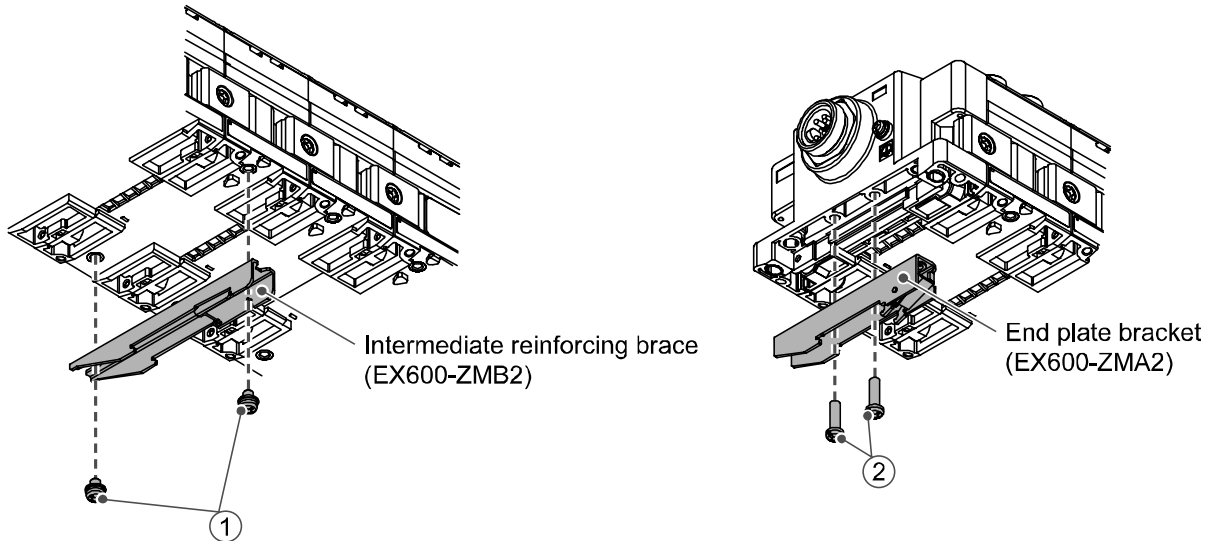

(3)Hook the DIN rail mounting groove on to the DIN rail.

(4)Press the manifold using its side hooked to the DIN rail as a fulcrum until the manifold is locked.

(5)Fix the manifold by tightening the DIN rail fixing screws of the EX600-ZMA2. (M4x20)

Tightening torque: 0.7 to 0.8 Nm.

The tightening torque at the valve side depends on the valve type.

Refer to the operation manual of the corresponding valve manifold.

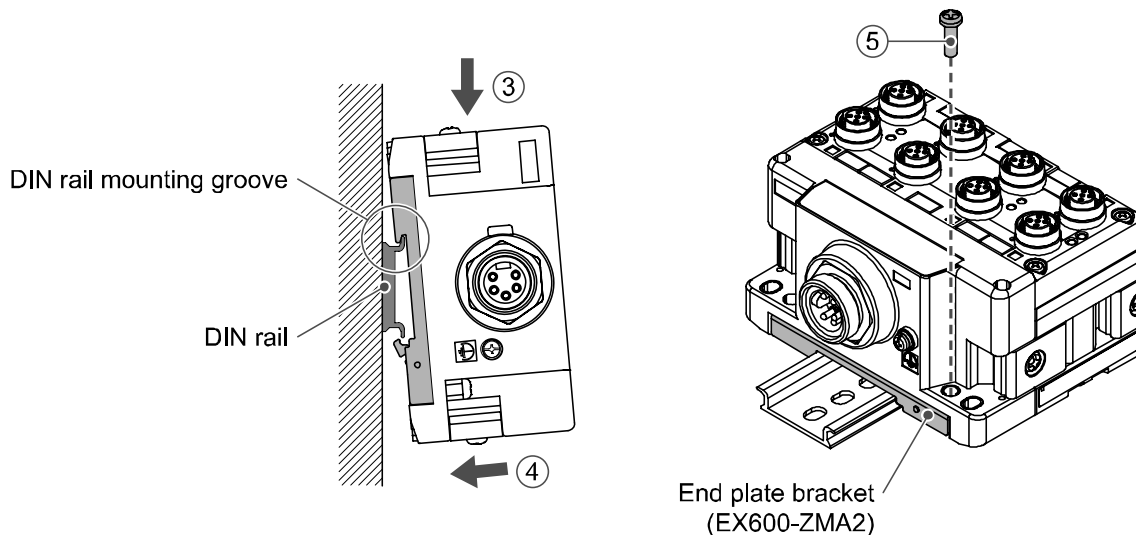

## ■Wiring

•Connect the M12 or M8 connector cable. M12 SPEEDCON connector connection method is explained below.

(1)Align mark B on the metal bracket of the cable connector (plug/socket) with mark A.

(2)Align with mark C on the unit and insert the connector vertically.

If they are not aligned, the connector cannot be connected correctly.

(3)When mark B has been turned 180 degrees (1/2 turn), wiring is complete. Confirm that the connection is not loose. If turned too far, it will become difficult to remove the connector.

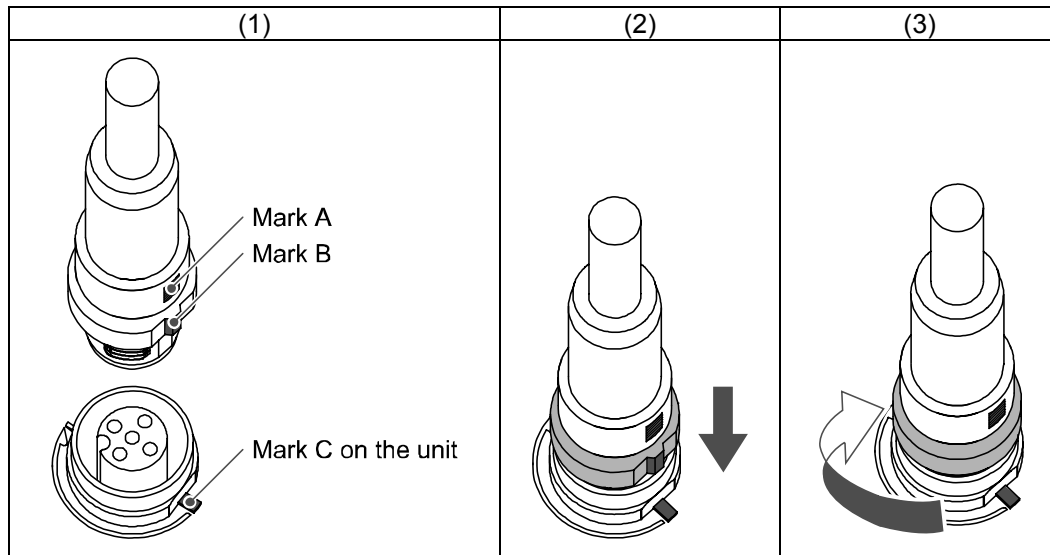

## •Identification marker

The signal name of the input or output devices and unit address can be written on the marker, and can be installed on each unit.

Mount the marker (EX600-ZT1) into the marker groove as required.

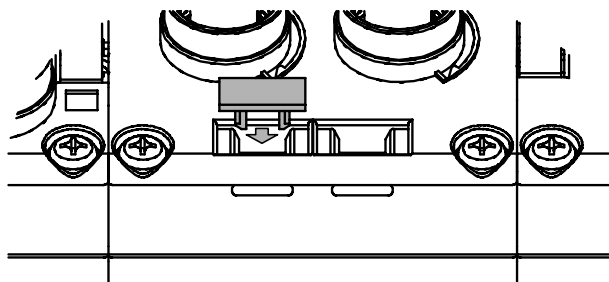

## SI unit

### Model Indication and How to Order

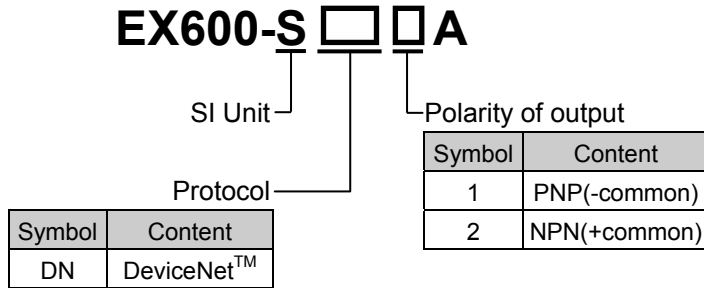

### Names and Functions of Product

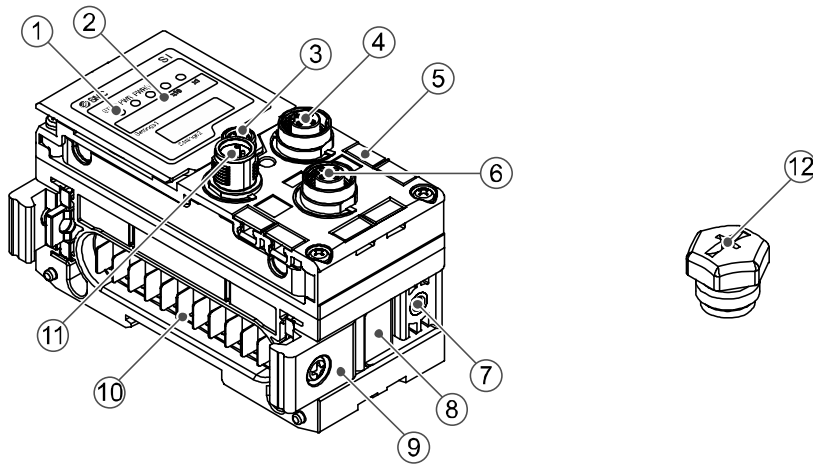

No.	Description	Function
1	Status display LED	Displays the status of the unit.
2	Display cover	Open to access the setting switches.
3	Display cover screw	Screw to open the display cover.
4	Connector (BUS OUT)	Connector for Fieldbus outputs.
5	Marker groove	Groove for an identification marker.
6	Connector (PCI)	Connector for Handheld Terminal.
7	Valve plate mounting hole	Holes for fixing the valve plate.
8	Valve plate mounting groove	Groove for mounting the valve plate.
9	Joint bracket	Bracket for joining to adjacent units.
10	Unit connector (Plug)	Connector for signals and power supplies to adjacent units.
11	Connector (BUS IN)	Connector for Fieldbus inputs.
12	Seal cap (2 pcs.)	Fitted to unused connectors (BUS OUT and PCI).

# Mounting and Installation

## ■Wiring

### ○Connector pin assignment and circuit diagram

#### •Connector pin assignment

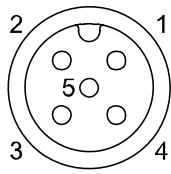
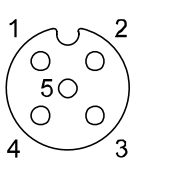
Configuration		Pin number	Signal name
BUS IN	BUS OUT		
		1	DRAIN
		2	V+
		3	V-
		4	CAN_H
		5	CAN_L

\*: If you are concerned about disruption of "downstream" device whilst replacing the SI unit, use a DeviceNet™ tap rather than marking connections to the BUS OUT connector.

#### •Circuit diagram

The product has T branching internally in the unit as shown in the circuit diagram below. It can be extended by connecting the DeviceNet™ slave with BUS OUT.

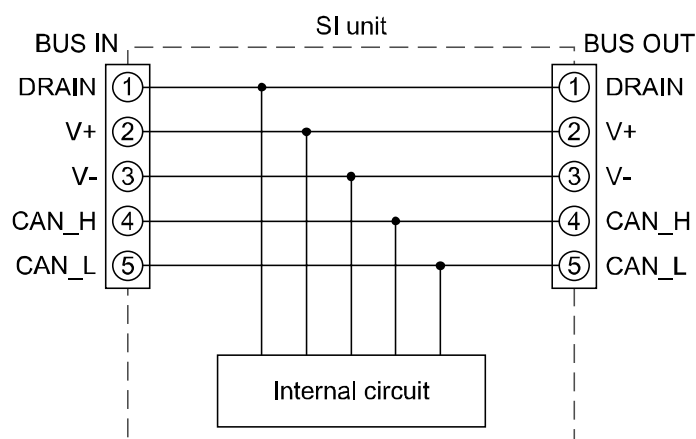

#### •Precautions for handling

- Be sure to fit a seal cap on any unused connectors. Proper use of the seal cap enables the enclosure to achieve IP67 specification.
- Please connect the terminator with both ends of the DeviceNet™ trunk line.

## Setting and Adjustment

### •Switch setting

- (1) Loosen the display cover screw.
- (2) Open the display cover using a flat head screwdriver, etc.

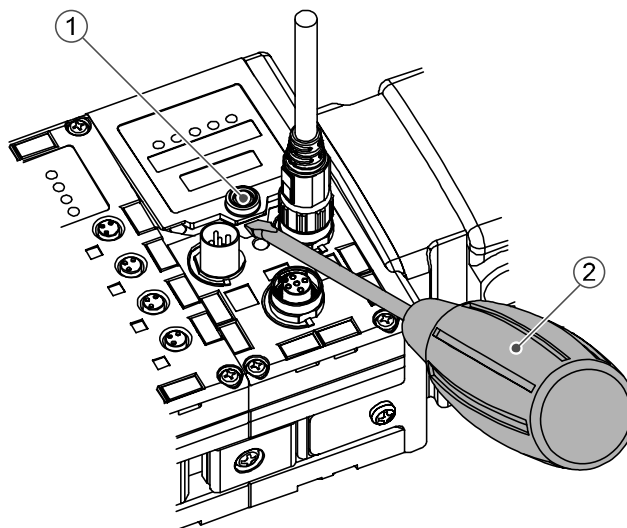

- (3) Set the switch using a small watchmaker's screwdriver with a thin blade, referring to the setting of switch on the following pages.
- (4) After setting the switch, tighten the display cover tightening screw in the reverse order of the above procedure. (Tightening torque: 0.3 to 0.4 Nm)

### •Precautions for handling

- Turn off the power supply whilst setting the switch.
- If there is foreign matter or water droplets around the display cover, clean it off before opening the cover.
- When setting the switch, do not touch other unrelated parts. This can cause parts damage or malfunction due to a short circuit.
- All default settings are off or 0. Perform the setting of the switch before using this product.
- When introducing power supply, switch setting will become effective.

•Address setting/Data Rate switch: Sets the DeviceNet™ node address and Data Rate.

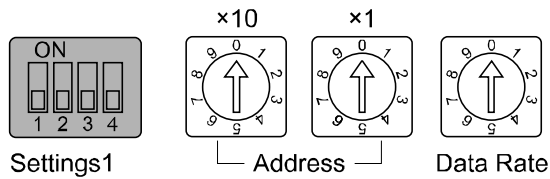

Address setting switch (x10): Sets the 10 digit of the DeviceNet™ node address.

Address setting switch (x1): Sets the 1 digit of the DeviceNet™ node address.

Data Rate switch: Sets DeviceNet™ communication speed.

#### Address setting

Address		Node Address
x10	x1	
0	0	0 (Default setting)
0	1	1
0	2	2
:	:	:
6	2	62
6	3	63
6	4	PGM *
:	:	
9	9	

#### Data Rate setting

Data Rate	Communication speed
0	125 kbps (Default setting)
1	250 kbps
2	500 kbps
3	PGM *
:	
9	

\*: When PGM is set, the data rate is set via DeviceNet™ network. Turn on HW/SW switch for setting.

- V\_SEL switch: A function to select the number of occupied valve outputs.  
The number of outputs (size) occupied by the SI unit is selected.

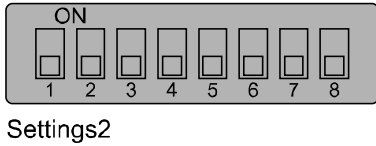
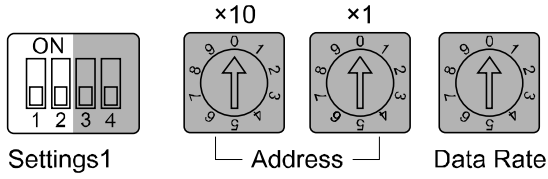

Settings1		Content	SI unit output data size
1	2		
OFF	OFF	Number of valves = 32 outputs	4 byte (Default setting)
OFF	ON	Number of valves = 24 outputs	3 byte
ON	OFF	Number of valves = 16 outputs	2 byte
ON	ON	Number of valves = 8 outputs	1 byte

\*: Set the number of occupied valve outputs to at least the number of valves used.

- Baud Rate switch: Sets the communication speed of the internal bus of the product.

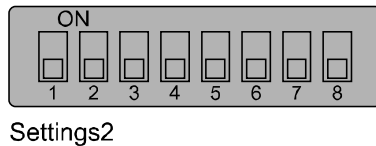
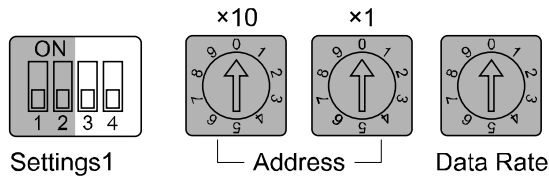

Settings1		Content
3	4	
OFF	OFF	1 Mbps (Default setting)
OFF	ON	500 kbps
ON	OFF	250 kbps
ON	ON	125 kbps

\*: This function is for possible extension. Keep the default setting of 1 Mbps.

•Diagnostics switch: Allocates the diagnostic data to the input data.

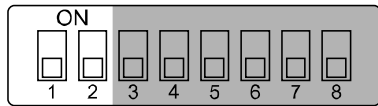
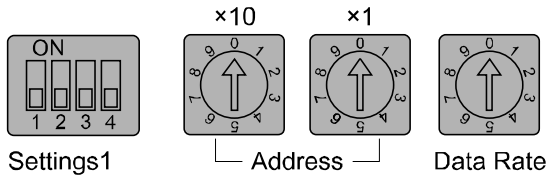

Settings2

Settings2		Mode	Content	Diagnostic size set for the input
1	2			
OFF	OFF	0	Input data only (Default setting)	0 byte
OFF	ON	1	Input data + System diagnosis	4 byte
ON	OFF	2	Input data + System diagnosis + Unit diagnosis (Up to 10 units)	6 byte
ON	ON	3 *	Input data + System diagnosis + Unit diagnosis (Up to 64 units)	12 byte

\*: Mode 3 is a function for extension in the future. Do not use it now.

•HOLD/CLEAR switch: Sets the output status when the Fieldbus has a communication error or is in idling state.

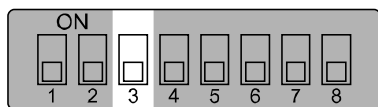
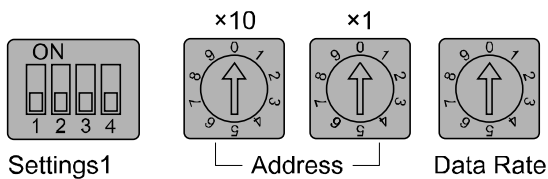

Settings2

Settings2	Content
3	
OFF	Output is OFF. (Default setting)
ON	Holds the output.

\*: Refer to "Parameter setting" (page 43), for the further details.

•HW/SW switch: Select the selection method of the Fieldbus address and Data Rate.

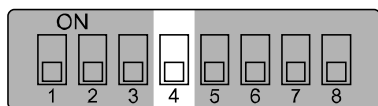
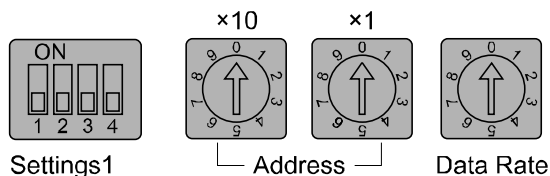

Settings2	Content
4	
OFF	Address and Data Rate are set by the SI unit switch. (Hardware) (Default setting)
ON	Address and Data Rate are set via the PLC. (Software) *

\*: In order to set software via network, set the address or Data Rate switch to PGM.

•Configuration memory switch: When the manifold configuration memory switch is set ON and the power supply is switched ON, the system will compare the stored configuration with the manifold configuration. If the configuration is different, diagnostic error will be generated.

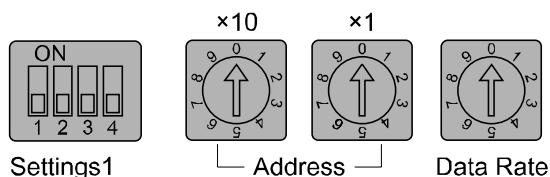

Settings2	Content
5	
OFF	Normal operation mode (Default setting)
ON	Configuration memory mode

- Timing to memorize the configuration → When power supply for control/input is turned on, with the switch above turned OFF.
- Timing to compare the configuration → When power supply for control/input is turned on, with the switch above turned ON.

•Precautions for handling

- Handle the switch with care excessive force can break the switch.
- Switches of No. 6, 7, 8 on the Setting2 switch are not use.

## LED Display

The status display LED displays the power supply and communication status.  
Various kinds of status can be checked as follows:

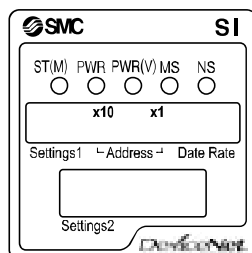









Display	Content
ST(M)	Displays the diagnostic status of the unit.
PWR	Displays the status of the power supply voltage for control and input.
PWR(V)	Displays the status of the power supply voltage for outputs.
MS	Displays the module status.
NS	Displays the network status.

### •SI unit common status

LED display	Content
ST(M) PWR PWR(V) ○ ○ ○ OFF.	The power supply for control and input is OFF.
ST(M) PWR PWR(V) ● ● ● Green LEDs are ON.	The unit is in normal operation.
ST(M) PWR PWR(V) ● ○ ○ Red ST(M) LED is ON.	A component failure inside the SI unit.
ST(M) PWR PWR(V) ○ ● ○ Red PWR LED is ON.	The power supply voltage for control and input is abnormal.
ST(M) PWR PWR(V) ○ ○ ● Red PWR(V) LED is ON.	The power supply voltage for outputs is abnormal.
ST(M) PWR PWR(V) ● (flashing) ○ ○ Green ST(M) LED is flashing.	A unit other than the SI unit has been detected.
ST(M) PWR PWR(V) ● (flashing) ○ ○ Red ST(M) LED is flashing.	Either of the following conditions: •The valve ON/OFF counter has exceeded the set value. •The valve is short circuited or disconnected.
ST(M) PWR PWR(V) ● (flashing) ○ ○ Red/Green ST(M) LED is flashing alternately.	Either of the following conditions: •Connection error between units has occurred. •Configuration memory error has occurred.

\*: Refer to "Troubleshooting" (page 34), for the further details of countermeasures.

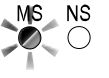
•DeviceNet™ status

LED display	Content
 <p>MS NS ○ ○ OFF.</p>	The power supply for control and input is OFF.
 <p>MS NS ● ○ Green MS LED is ON and NS LED is OFF.</p>	Either of the following conditions: •Checking the node address. •Communication error.
 <p>MS NS ● ● Green MS and NS LEDs are both ON.</p>	Communication is normal.
 <p>MS NS ● ● Green MS LED is ON and Green NS LED is flashing.</p>	Connection is not established.
 <p>MS NS ● ○ Red MS LED is ON.</p>	A component failure inside the SI unit.
 <p>MS NS ● ● Green MS LED is ON and Red NS LED is ON.</p>	Fatal communication error. (Check the following items, and restart.) •Check/correct the node address. •Check if the communication speed of PLC is the same as that of the slave. If they are not the same, correct them. •Check proper length of the cable. •Check the communication cable is not disconnected or loose. •Ensure that the terminal resistor is mounted properly.
 <p>MS NS ● ● Green MS LED is ON and Red NS LED is flashing.</p>	Minor communication error. (Check the following items, and restart.) •Check if the communication speed of PLC is the same as that of the slave. If they are not the same, correct them. •Check proper length of the cable. •Check the communication cable is not disconnected or loose. •Ensure that the terminal resistor is mounted properly.
 <p>MS NS ● ○</p> <p>↓</p>  <p>MS NS ○ ●</p> <p>Red/Green MS LED is flashing alternately. Then, Red/Green NS LED is flashing alternately.</p>	Flashes when performing self diagnosis test when the power supply starts.

\*: Refer to "Troubleshooting" (page 34), for the further details of countermeasures.

# Specification

## ■ Specifications

Model		EX600-SDN1A	EX600-SDN2A
Communication	Fieldbus	DeviceNet™ Volume1 (Edition2.1) Volume3 (Edition1.1)	
	Device type	12(Communication Adapter)	
	Slave type	Group2 only server	
	Communication speed	125/250/500 kbps	
	Configuration file	EDS file	
	Occupied area (Number of inputs/outputs)	(512 inputs/512 outputs) max.	
	Corresponding messeje	Duplicate MAC ID Check Message Group 2 Only Unconnected Explicit Message Explicit Message (Group 2) Poll I/O message (Predefined M/S Connection set)	
Power supply for DeviceNet™		11 to 25 VDC	
Internal current consumption (The power supply for control and input)		55 mA or less	
Output specifications	Polarity of output	PNP (-common)	NPN (+common)
	Output channel	32 outputs (8/16/24/32 outputs selectable)	
	Connected load	24 VDC 1.5 W (SMC) Solenoid valve with LED and circuit protection	
	Power supply	24 VDC, 2 A	
	Output for communication error	HOLD/CLEAR/Force ON	
	Protective function	Short circuit protection	
Environment	Enclosure	IP67 (With manifold assembled)*1	
	Operating temperature range	-10 to 50 °C (Max. surrounding air temperature rating: 50 °C)	
	Storage temperature range	-20 to 60 °C	
	Operating humidity range	35 to 85%RH (No condensation)	
	Withstand voltage	500 VAC for 1 minute between external terminals and FE	
	Insulation resistance	500 VDC, 10 MΩ or more between external terminals and FE	
	Pollution degree	For use in Pollution Degree 3 Environment (UL508)	
Standard		CE marking, UL (CSA) , RoHS	
Weight		300 g	

\*1: All unused connectors must have the seal cap fitted.

## ■Dimensions

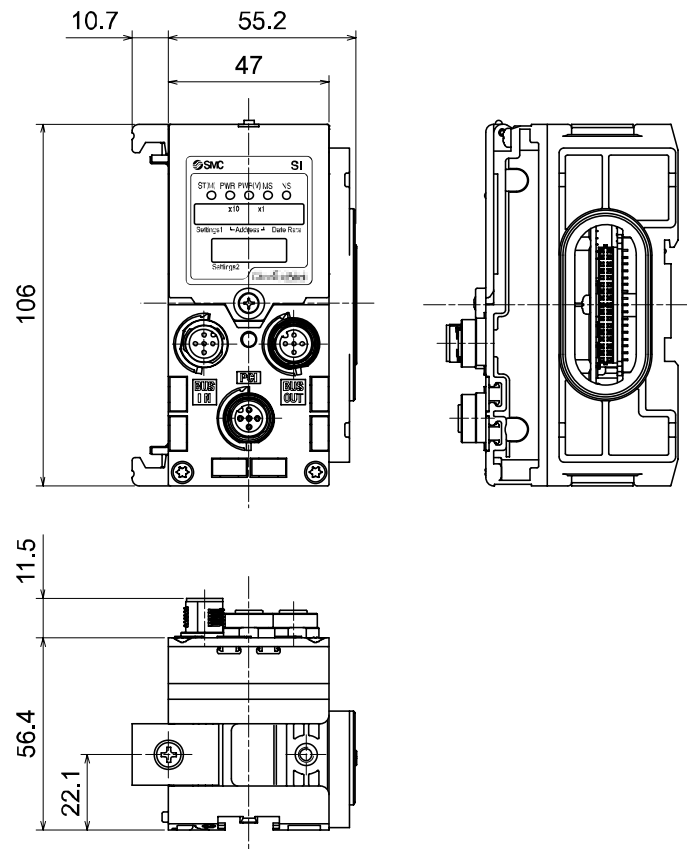

# End plate

## Model Indication and How to Order

**EX600-ED□-□**

End plate at D side

Mounting method

Connector

Symbol	Content
2	M12 (5 pin)
3	7/8 inch (5 pin)

Symbol	Content
Nil	No DIN rail bracket
2	With DIN rail bracket
3	With DIN rail bracket (Specified for SY series)

## Names and Functions of Product

•EX600-ED2-□

•EX600-ED3-□

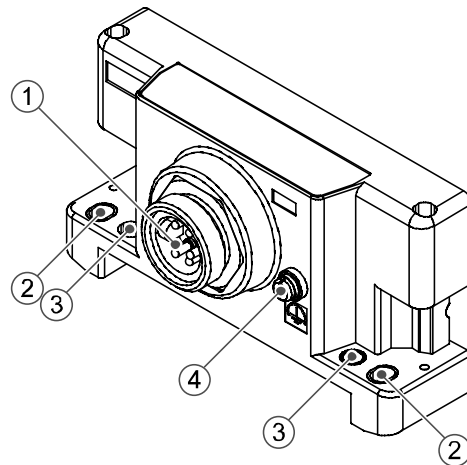
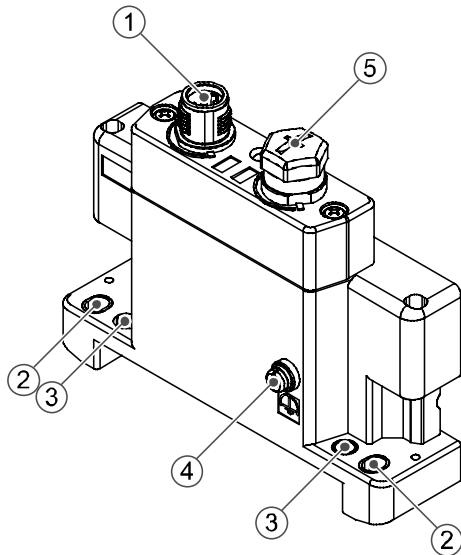

No.	Description	Function
1	Power connector	Supplies power for each unit and input/output device.
2	Fixing hole for direct mounting	Holes used for direct mounting.
3	DIN rail fixing hole	Holes used to fix DIN rail.
4	FE terminal	Terminal used to grounding.
5	Connector (Not used)	This connector is not used. Do not take off the seal cap.

# Mounting and Installation

## ■Wiring

### ○Connector pin assignment

#### (1)EX600-ED2-□

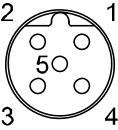
Configuration	Pin No.	Signal name
	1	24 V (Output)
	2	0 V (Output)
	3	24 V (Control and input)
	4	0 V (Control and input)
	5	FE

#### (2)EX600-ED3-□

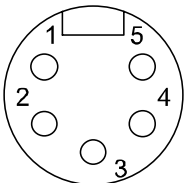
Configuration	Pin No.	Signal name
	1	0 V (Output)
	2	0 V (Control and input)
	3	FE
	4	24 V (Control and input)
	5	24 V (Output)

### ○Regarding the 2 types of power supply

This product has 2 power supplies, and it is divided as follows.

- Power supply for control and input: Supplying power for control of each unit's power supply for control and also for device connected to input port of Digital and Analog unit.
- Power supply for output: Supplying power for equipment connected to output port of Digital and Analog unit, and also power supply for solenoid valve manifold.

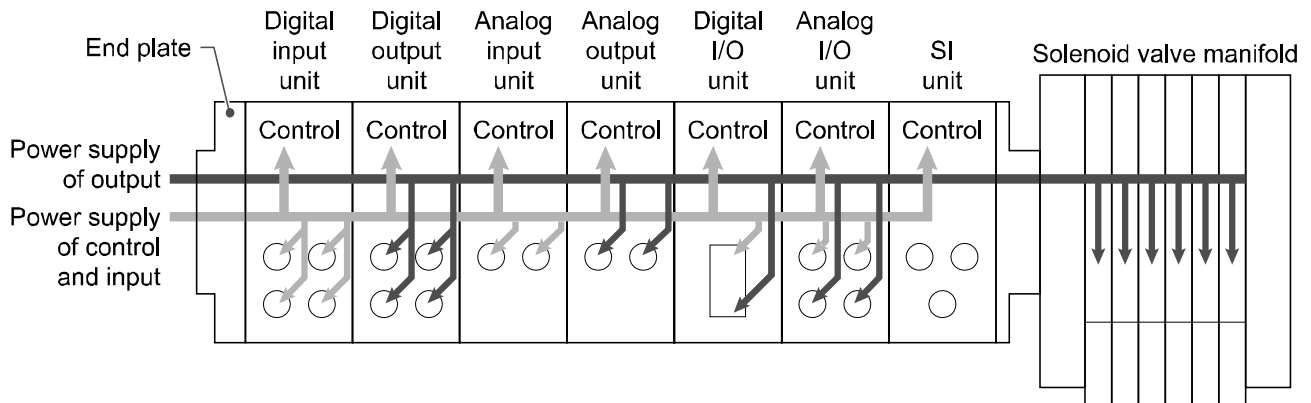

#### ●Precautions for handling

Be sure to fit a seal cap on any unused connectors. Proper use of the seal cap enables the enclosure to achieve IP67 specification.

# Specification

## ■ Specifications

Model		EX600-ED2-□	EX600-ED3-□
Power specifications	Power connector	M12 (5 pin) Plug	7/8 inch (5 pin) Plug
	Power supply (Control and input)	24 VDC ±10% Class2, 2 A	24 VDC ±10%, 8 A
	Power supply (Output)	24 VDC +10/-5% Class2, 2 A	24 VDC +10/-5%, 8 A
Environment	Enclosure	IP67 (With manifold assembled) <sup>*1</sup>	
	Operating temperature range	-10 to 50 °C (Max. surrounding air temperature rating: 50 °C)	
	Storage temperature range	-20 to 60 °C	
	Operating humidity range	35 to 85%RH (No condensation)	
	Withstand voltage	500 VAC for 1 minute between external terminals and FE	
	Insulation resistance	500 VDC, 10 MΩ min. between external terminals and FE	
	Pollution degree	For use in Pollution Degree 3 Environment (UL508)	
Standard	CE marking, UL(CSA), RoHS		
Weight	170 g	175 g	

\*1: All unused connectors must have a seal cap fitted.

## ■ Dimensions

### •EX600-ED2-□

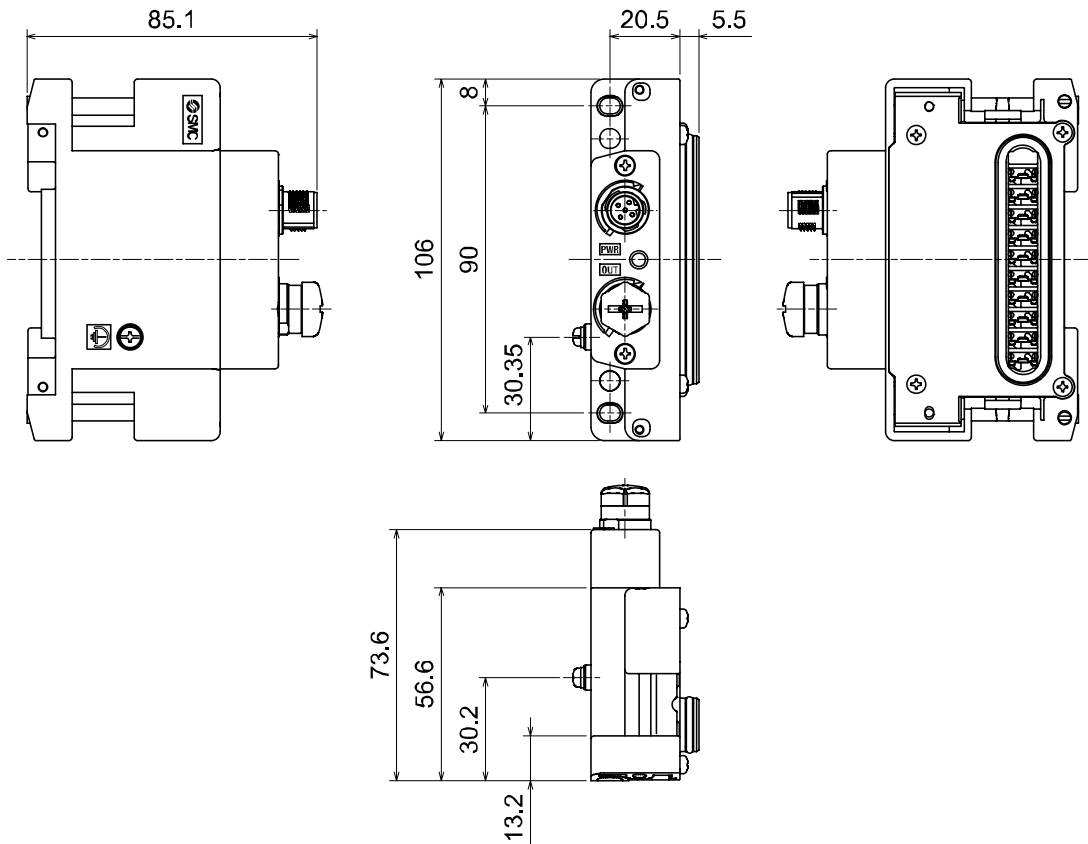

•EX600-ED3-□

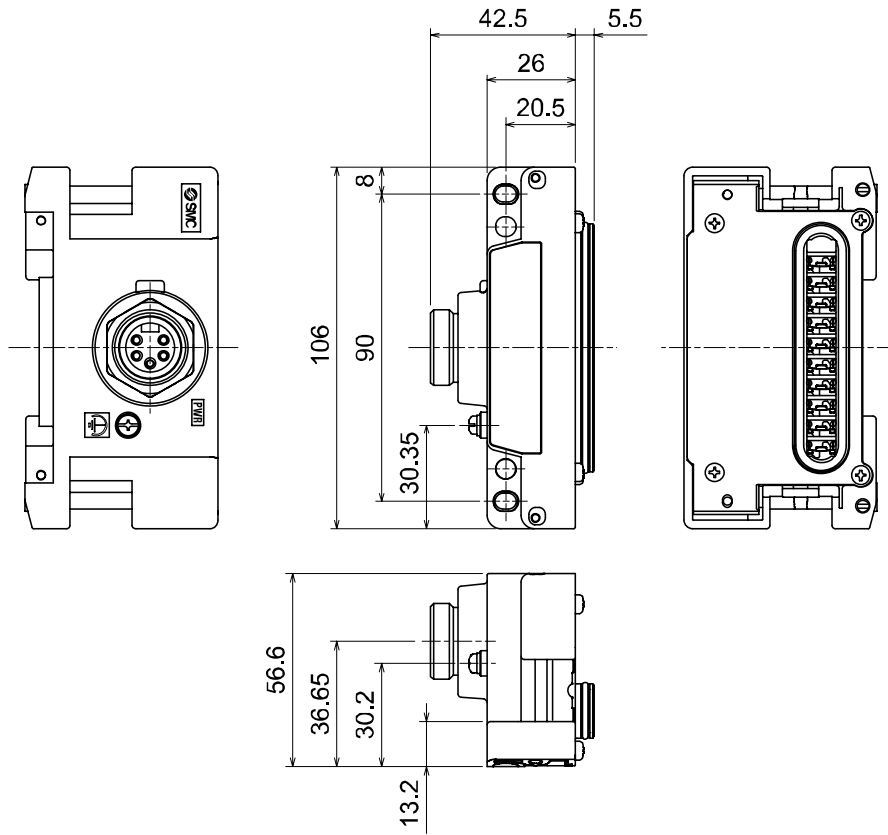

## Maintenance

Turn off the power supply, stop the supplied air, exhaust the residual pressure and verify the release of air before performing maintenance.

### Cleaning method

Use a soft cloth to remove stains.

For heavy stains, use a cloth soaked with diluted neutral detergent and fully squeezed, then wipe up the stains again with a dry cloth.

Do not use solvents such as benzene, thinner etc. to clean each unit.

Inspection item	Content of inspection
Connector/Electric wiring	Connect properly if the connection is loose.
Seal cap	Tighten properly if the connection is loose.
Thread for mounting and installation	If the thread is loose, re-tighten it to the specified torque.
Connection cables	If the cable is broken or any other abnormality is confirmed by appearance, replace the cable with a new one.
Supply source voltage	Check if source voltage within the specification range (24 VDC $\pm$ 10%) is supplied.

### How to reset the product for power cut or forcible de-energizing

Supply power to the product.

The output status just before the power failure is not maintained when power supply is recovered.

Start operation after confirming safety of the entire equipment.

# Troubleshooting

## •Troubleshooting

When any failure happens with this fieldbus system, the following chart is used to identify the cause of the failure.

Error status is reflected from the parameter setting of the fieldbus system.

When a failure occurs, take the appropriate countermeasures referring to the LED display, the troubleshooting and the parameter setting.

If a cause applicable to the failure cannot be identified, it indicates that the fieldbus system itself is broken. The fieldbus system breakage can be caused by the operating environment. Contact SMC separately to obtain countermeasures.

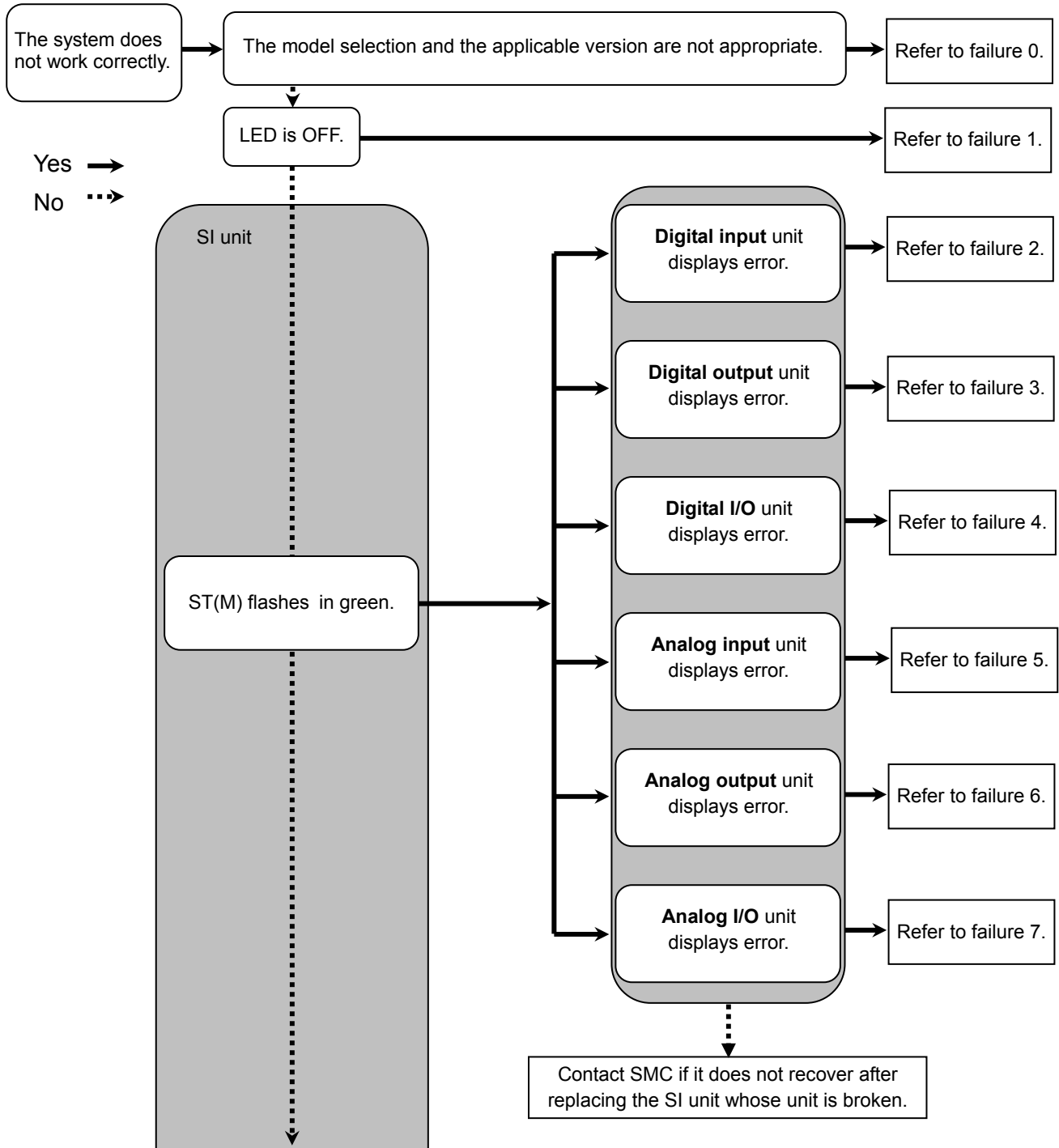

¥

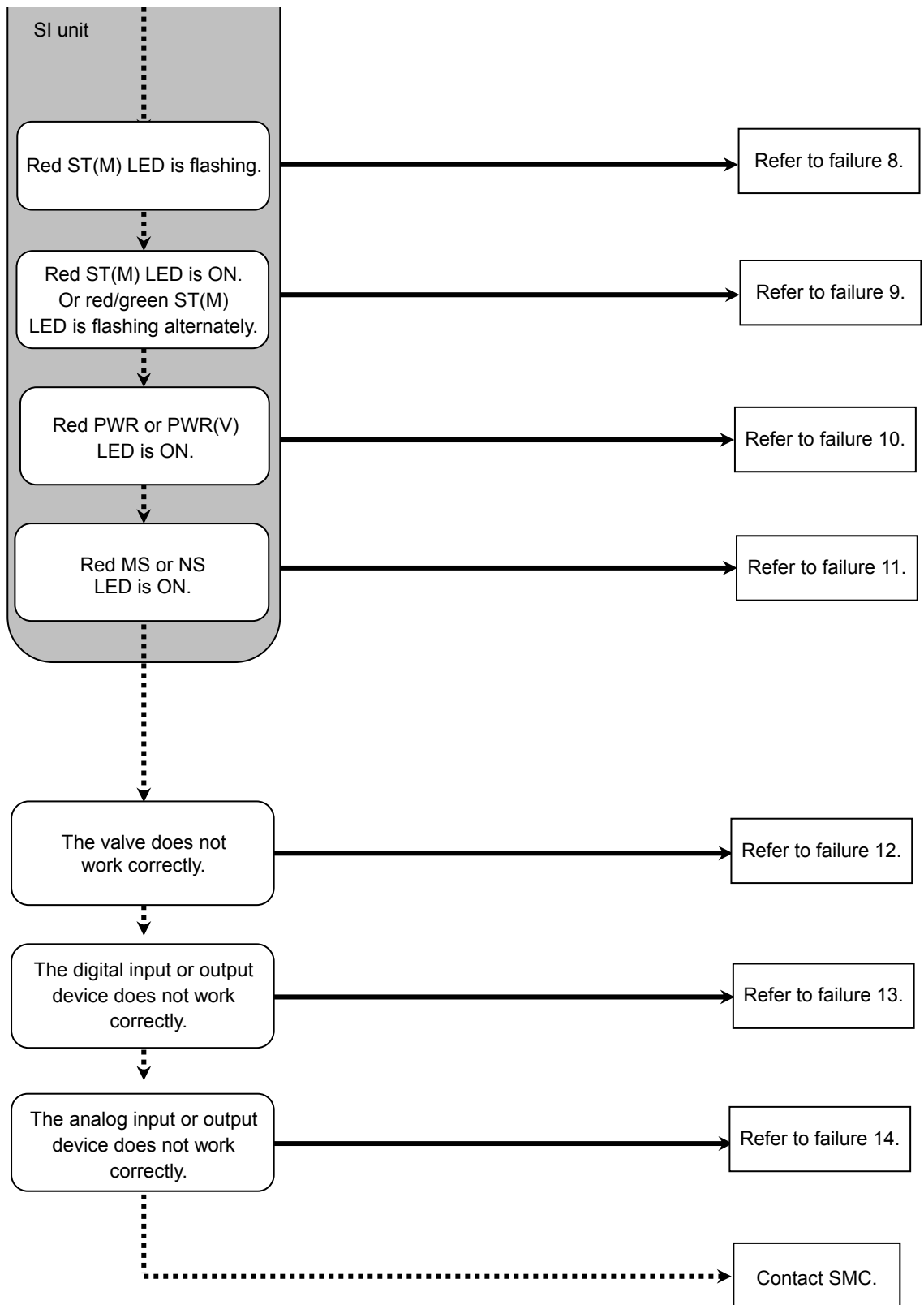

•Trouble counter measure method

No.	Part No. EX600-	Problem	presumed cause	Troubleshooting
0	-	The system does not work correctly.	Inappropriate unit selection.	The types of units that can be connected vary depending on the SI unit part number. Check if the unit is applicable before assembly. Refer to “Units that can be assembled” (page 12) in the section “Assembly” for details.
1	-	LED is OFF.	Power supply for control and input is OFF.	Check if the power for control and input is supplied.
2	DX□B DX□C□ DX□D	Red LED is ON. (Diagnosis is activated)	Diagnosis error Input device power supply is short-circuited.	Check the parts with error by using the LED display or PLC* or H.T. Re-wire the short-circuited part or check if the cable and input device are normal.
		Red LED is flashing. (Diagnosis is activated)	Diagnosis error (1)ON/OFF count of the input device has exceeded the set value. (2)The wire of the input device is broken or disconnected. (Only EX600-DX□C1)	Check the parts with error by using the LED display or PLC* or H.T. (1)Reset the ON/OFF count to zero or change the set value. Or invalidate diagnosis. (2)Check if the connector is loose and if the wire is broken.
		Red/green all LEDs are flashing.	Unit has failed.	Stop the operation and contact SMC.
	DX□E DX□F	Red ST LED is ON. (Diagnosis is activated)	Diagnosis error Input device power supply is short-circuited.	Check the parts with error by using the LED display or PLC* or H.T. Re-wire the short-circuited part or check if the cable and input device are normal.
		Red ST LED is flashing. (Diagnosis is activated)	Diagnosis error ON/OFF count of the input device has exceeded the set value.	Check the parts with error by using the LED display or PLC* or H.T. Reset the ON/OFF count to zero or change the set value. Or invalidate diagnosis.
		Red/green ST LED is flashing.	Unit has failed.	Stop the operation and contact SMC.

\*: Refer to “Diagnosis” (page 62) for the further details.

No.	Part No. EX600-	Problem	Presumed cause	Troubleshooting
3	DY□B	Red LED is ON. (Diagnosis is activated)	Diagnosis error Output device is short-circuited.	Check the parts with error by using the LED display or PLC* or H.T. Re-wire the short-circuited part or check if the cable and output device are normal.
		Red LED is flashing. (Diagnosis is activated)	Diagnosis error (1)ON/OFF count of the output device has exceeded the set value. (2)The wire of the output device is broken or disconnected.	Check the parts with error by using the LED display or PLC* or H.T. (1)Reset the ON/OFF count to zero or change the set value. Or invalidate diagnosis. (2)Check if the connector is loose and if the wire is broken.
		Red/green all LEDs are flashing.	Unit has failed.	Stop the operation and contact SMC.
	DY□E DY□F	Red ST LED is ON. (Diagnosis is activated)	Diagnosis error Output device is short-circuited.	Check the parts with error by using the LED display or PLC* or H.T. Re-wire the short-circuited part or check if the cable and output device are normal.
		Red ST LED is flashing. (Diagnosis is activated)	Diagnosis error (1)ON/OFF count of the output device has exceeded the set value. (2)The wire of the output device is broken or disconnected.	Check the parts with error by using the LED display or PLC* or H.T. (1)Reset the ON/OFF count to zero or change the set value. Or invalidate diagnosis. (2)Check if the connector is loose and if the wire is broken.
		Red/green ST LED is flashing.	Unit has failed	Stop the operation and contact SMC.
4	DM□E DM□F	Red ST(I) LED is ON. (Diagnosis is activated)	Diagnosis error Input device power supply is short-circuited.	Check the parts with error by using the LED display or PLC* or H.T. Re-wire the short-circuited part or check if the cable and input device are normal.
		Red ST(I) LED is flashing. (Diagnosis is activated)	Diagnosis error ON/OFF count of the input device has exceeded the set value.	Check the parts with error by using the LED display or PLC* or H.T. Reset the ON/OFF count to zero or change the set value. Or invalidate diagnosis.
		Red ST(O) LED is ON. (Diagnosis is activated)	Diagnosis error Output device is short-circuited.	Check the parts with error by using the LED display or PLC* or H.T. Re-wire the short-circuited part or check if the cable and output device are normal.
		Red ST(O) LED is flashing (Diagnosis is activated)	Diagnosis error 1) ON/OFF count of the output device has exceeded the set value. 2) The wire of the output device is broken or disconnected.	Check the parts with error by using the LED display or PLC* or H.T. (1)Reset the ON/OFF count to zero or change the set value. Or invalidate diagnosis. (2)Check if the connector is loose and if the wire is broken.
		Red/green ST LED is flashing.	Unit has failed	Stop the operation and contact SMC.

\*: Refer to "Diagnosis" (page 62) for the further details.

No.	Part No. EX600-	Problem	Presumed cause	Troubleshooting
5	AXA	Red LED is ON. (Diagnosis is activated)	Diagnosis error Analog input device power supply is short-circuited.	Check the parts with error by using the LED display or PLC* or H.T. Re-wire the short-circuited part, and check if the cable and analog input device are normal.
		"0 and 1" red LEDs are ON.	Input value has exceeded the upper limit when set to current input type range.	Check the following when the range of the analog input unit is set to current input. (1)Set the input value of the analog input device so that it does not exceed the upper limit. (2)Voltage is input from the analog input device. Ensure the range of the input unit matches the range of the input device.
		Red LED is flashing. (Diagnosis is activated)	Diagnosis error (1)Input value has exceeded the upper or lower limit of the range. (2)Input value (value set by user) has exceeded the upper or lower limit.	(1)If the input value from the analog input device exceeds the upper or lower limit of the range, select the appropriate range so that the input value is within the range. Or invalidate diagnosis. (2)If the input value from the analog input device exceeds the upper or lower limit of the user set value, adjust it so that the input value is within the range of the user set value. Or invalidate diagnosis.
		Red/green all LEDs are flashing.	Unit has failed	Stop the operation and contact SMC.
6	AYA	Red LED is ON. (Diagnosis is activated)	Diagnosis error Analog output device power supply is short-circuited.	Check the parts with error by using the LED display or PLC* or H.T. Re-wire the short-circuited part, and check if the cable and analog output device are normal.
		Red LED is flashing. (Diagnosis is activated)	Diagnosis error Output value (value set by user) has exceeded the upper or lower limit.	If the output value from the analog output device exceeds the upper or lower limit of the user set value, adjust it so that the output value is within the range of the user set value. Or invalidate diagnosis.
		Red/green all LEDs are flashing.	Unit has failed.	Stop the operation and contact SMC.

\*: Refer to "Diagnosis" (page 62) for the further details.

No.	Part No. EX600-	Problem	Presumed cause	Troubleshooting
7	AMB	Red LED is ON. (Diagnosis is activated)	Diagnosis error Analog input or output device power supply is short-circuited.	Check the parts with error by using the LED display or PLC* or H.T. Re-wire the short-circuited part, and check if the cable and analog input or output device are normal.
		"0 and 1" red LEDs are ON.	Input value has exceeded the upper limit when set to Current input type range.	Check the following when the range of the analog input unit is set to current input. (1)Set the input value of the analog input device so that it does not exceed the upper limit. (2)Voltage is input from the analog input device. Ensure the range of the input unit matches the range of the input device.
		Red LED is flashing. (Diagnosis is activated)	Diagnosis error (1)Input value has exceeded the upper or lower limit of the range. (2)Input or output value (value set by user) has exceeded the upper or lower limit.	(1)If the input value from the analog input device exceeds the upper or lower limit of the range, select the appropriate range so that the input value is within the range. Or invalidate diagnosis. (2)If the input (output) value from the analog input (output) device exceeds the upper or lower limit of the user set value, adjust it so that the input (output) value is within the range of the user set value. Or invalidate diagnosis.
		Red/green all LEDs are flashing.	Unit has failed.	Stop the operation and contact SMC.
8		Red ST(M) LED is flashing. (Diagnosis is activated)	Diagnosis error (SI unit) (1)Valve is short-circuited. (2)Valve is open-circuited. (3)ON/OFF count of the valve has exceeded the set value.	Check the parts with error by using the LED display or PLC* or H.T. (1)Check the operation after replacing the valve. (2)Check the operation after replacing the valve. (3)Reset the ON/OFF count to zero or change the set value. Or invalidate diagnosis.
9		Red ST(M) LED is ON.	SI unit has failed.	Stop the operation and contact SMC.
		Red/green ST(M) LED is flashing alternately.	(1)Connection between the units is defective. (2)Configuration memory error.	(1)Confirm that there is no loose connection between the units and connect them correctly. (2)Unit layout is not the same as the unit layout when it was memorized. Return the layout to the same as when it was memorized, or update the configuration memory, or turn off the configuration memory function.
10		Red PWR LED is ON. (Diagnosis is activated)	Power supply voltage for control and input is abnormal.	Supply 24 VDC $\pm$ 10% for control and input power source.
		Red PWR(V) LED is ON. (Diagnosis is activated)	Power supply voltage for output is abnormal.	Supply 24 VDC +10/-5% for output power source.

\*: Refer to "Diagnosis" (page 62) for the further details.

No.	Problem	Presumed cause	Troubleshooting
11	MS: Green LED is ON NS: OFF	(1)Node address duplicated. (2)Communication error.	(1)Restart after setting so that the node address is not duplicated. (2)The communication speed of PLC and SI unit are different. Match the communication speed of PLC and SI unit, and restart.
	MS: Green LED is ON NS: Green LED is flashing	Waiting for connection.	Check PLC is operating properly. Refer to the PLC operation manual for details. If the network is using a scan list, check that the slave is registered correctly into the scan list.
	MS: Red LED is ON	SI unit failure.	Stop the operation and contact SMC.
	MS: Green LED is ON NS: Red LED is ON or Flashing	DeviceNet™ communication error.	Check the following, or reset then restart. •Ensure that the node address is not duplicated. •Match the communication speed of PLC and SI unit. •Use a cable of appropriate length. •Check the communication cable is not disconnected or loose. •Connect terminal resistors to both ends of the network. •Keep noise sources away from the communication line.
12	Abnormal valve operation	The number of connected valves is larger than the number of occupied valve outputs.	When the number of occupied valves of the V_SEL switch is smaller than the number of connected valves, set the switch so that the number of occupied valves is not smaller than the number of valves to be used.
		Abnormality with program, etc.	Check if the ladder program of PLC, etc. is correct.
		Abnormal power supply for output.	Check if the green PWR(V) LED of the SI unit is ON. If the LED is OFF, or the red LED is ON, supply 24V DC +10/-5% to the power supply for output.
		Connection between SI unit and manifold valve is defective.	Check the connectors between the SI unit and manifold valve are not damaged, such as bent pins, and connect them correctly.
		Polarity of output does not match.	IF the polarity of the SI unit and the valve are different, replace one of them to make the combination match. •EX600-SDN1A (PNP output) ⇒ -common type valve •EX600-SDN2A (NPN output) ⇒ +common type valve
		SI unit has failed.	Replace the SI unit with a normal one, and check the operation.
Valve failure.	Replace the valve with a normal one, and check the operation. Or refer to the troubleshooting of the valve used.		

No.	Problem	Presumed cause	Troubleshooting
13	Abnormal digital input device operation	Polarity of input does not match.	If the polarity (PNP, NPN) of the input unit and the input device are different, replace one of them to make the combination match.
		Power supply for control and input is abnormal.	Check if the green PWR LED of the SI unit is ON. If the LED is OFF, or the red LED is ON, supply 24 VDC $\pm 10\%$ to the power supply for control and input.
		Wiring or connection is defective.	Connect the wiring correctly between the digital input device and the digital input unit.
		Input unit has failed.	Replace the input unit with a normal one, and check the operation.
		Input device failure.	Replace the input device with a normal one, and check the operation. Or refer to the troubleshooting of the input device used.
	Abnormal digital output device operation	Polarity of output does not match.	If the polarity (PNP, NPN) of the output unit and the output device are different, replace one of them to make the combination match.
		Power supply for output is abnormal.	Check if the green PWR(V) LED of the SI unit is ON. If the LED is OFF, or the red LED is ON, supply 24 VDC $+10/-5\%$ to the power supply for output.
		Wiring or connection is defective.	Connect the wiring correctly between the digital output device and the digital output unit.
		Output unit has failed.	Replace the Output unit with a normal one, and check the operation.
		Output device failure.	Replace the output device with a normal one, and check the operation. Or refer to the troubleshooting of the output device used.
		Program etc. is defective.	Check whether the ladder program etc. of PLC are correct.

No.	Problem	Presumed cause	Troubleshooting
14	Abnormal analog input device operation	Power supply for control and input is abnormal.	Check if the green PWR LED of the SI unit is ON. If the LED is OFF, or the red LED is ON, supply 24 VDC $\pm 10\%$ to the power supply for control and input.
		Analog input signal range setting failure.	Check the analog input device specification, and set the input signal range which satisfies the specification.
		Analog data format does not match.	Check whether the data format of the analog input unit is properly set.
		Wiring or connection is defective.	Connect the wiring correctly between the analog input device and the analog input unit.
		Analog input unit has failed.	Replace the analog input unit with a normal one, and check the operation.
		Analog input device failure.	Replace the analog input device with a normal one, and check the operation. Or refer to the troubleshooting of the analog input device used.
	Abnormal analog output device operation	Power supply for output is abnormal.	Check if the green PWR(V) LED of the SI unit is ON. If the LED is OFF, or the red LED is ON, supply 24 VDC $+10/-5\%$ to the power supply for output.
		Analog output signal range setting failure.	Check the analog output device specification, and set the output signal range which satisfies the specification.
		Analog data format does not match.	Check whether the data format of the analog output unit is properly set.
		Wiring or connection is defective.	Connect the wiring correctly between the analog output device and the analog output unit.
		Analog output unit has failed.	Replace the analog output unit with a normal one, and check the operation.
		Analog output device failure.	Replace the analog output device with a normal one, and check the operation. Or refer to the troubleshooting of the analog output device used.
		Program etc. is defective.	Check whether the ladder program etc. of PLC are correct.

## Parameter Setting

The product has parameters that can be set for the system, each unit or each channel.  
 The parameters can be changed using the PLC and H.T.  
 There is no order of precedence of the PLC and H.T. The latest parameter settings are used.

### ●Precautions for handling

- Changing parameters with the H.T. does not change the parameter settings in the PLC.
- If DeviceNet™ parameters are downloaded from the configurator to the PLC after changing parameters with the H.T., parameters will be changed to those which are set by the configurator. Therefore, set parameters by PLC if the parameters can be changed by both PLC and H.T.

### ■Parameter definition and setting

#### •System parameters

No.	Parameter (H.T. Symbol)	Definition	Item	Content	Default setting	Parameter setting	
						By PLC	By H.T.
1	Hold/Clear priority setting (Hold/Clear)	Switch the setting of the output during communication error or communication idling to follow the SI unit switch or the parameters	Switch	Setting by SI unit switch becomes valid. OFF/Hold can be set all outputs.	○		
			Handheld	Setting by EDS file, DeviceNet™ object or the H.T. becomes valid. OFF/Hold/Forced ON can be set per channel.		○	○

•SI unit parameters

No.	Parameter (H.T. Symbol)	Definition	Item	Content	Default setting	Parameter setting	
						By EDS	By H.T.
1	Power supply for control and input voltage monitor (PWRC_Mon)	Generated error per unit when control and input power supply voltage goes over approx. 26V or under 21V.	Enable	Generates an error.	○	○	○
			Disable	Does not generate an error.			
2	Power supply for output voltage monitor (PWRO_Mon)	Generated error per unit when output power supply voltage goes over approx. 26V or under 20 V.	Enable	Generates an error.	○	○	○
			Disable	Does not generate an error.			
3	Short Circuit Detection (SC_MonOp)	Generates error per unit when the short circuit of the valve is detected.	Enable	Generates an error.	○	○	○
			Disable	Does not generate an error.			
4	Restart after short circuit (SC_RstOp)	Restore the setting of short circuit detection error per unit after the valve short circuit is cleared.	Auto	Error is automatically cleared when the short circuit is fixed.	○	○	○
			Manual	Even when the short circuit is fixed, error is not cleared until the power is supplied again.			
5	Open Circuit Detection (OC_Mon)	Generates error per channel when the disconnection of the valve is detected.	Enable	Generates an error.		△ <sup>*5</sup>	○
			Disable	Does not generate an error.	○		
6	Output setting during communication fault <sup>*1</sup> (Fault_MD)	Set output per channel when communication is abnormal.	Clear	Turn off the output.	○	△ <sup>*5</sup>	○
			Hold	Hold the output.			
			ForceON	Turn on the output forcefully.			
7	Output setting during communication idling <sup>*1 *2</sup> (Idle_MD)	Set output per channel during communication idling	Clear	Turn off the output.	○	△ <sup>*5</sup>	○
			Hold	Hold the output.			
			ForceON	Turn on the output forcefully.			

No.	Parameter (H.T. Symbol)	Definition	Item	Content	Default setting	Parameter setting	
						By EDS	By H.T.
8	Valve ON/OFF counter (Counter)	Memorizes the number of times the valve is ON. Generates error per channel when the operation count exceeds the set value. *3	Enable	Generates an error. Val: 1 to 65000 *4		Δ *5	○
			Disable	Does not generate an error.	○		

\*1: This function is valid only when "Hold/Clear priority" of the system parameter is set to H.T.

\*2: Some PLC does not support an idle mode.

\*3: The count is memorized every 30 seconds per channel. When the power supply is turned on again, counting starts from the last value memorized.

\*4: Times for setting is set value x1000 times.

\*5: It is possible to set it only with DeviceNet™ extended object library 2.

•Digital input unit parameters

No.	Parameter (H.T. Symbol)	Definition	Item	Content	Default setting	Parameter setting	
						By EDS	By H.T.
1	The power supply short circuit detection for control and input (SC_MonSs)	Generates error per unit when the short circuit of the power supply for the input device is detected.	Enable	Generates an error.	○	○	○
			Disable	Does not generate an error.			
2	Open circuit detection *1 (OC_Mon)	Generates error per channel when the disconnection of the input device is detected. *2	Enable	Generates an error.		△ *5	○
			Disable	Does not generate an error.	○		
3	Inrush current filter (Inrush)	Ignores excess current per unit for 100 msec after inrush.	Enable	Ignores excess current.		○	○
			Disable	Does not ignore excess current.	○		
4	Input filtering time (Filter_T)	Sets the time to ignore the input signal change per unit.	0.1 ms	Selects the time for filtering.	1.0 ms	○	○
			1.0 ms				
			10 ms				
			20 ms				
5	Input extension time (SigExt_T)	Sets the time to hold the input signal per unit.	1.0ms	Selects the time to hold the input signal.	15 ms	○	○
			15 ms				
			100 ms				
			200 ms				
6	Channel ON/OFF counter (Counter)	Memorizes the number of times the input device is ON. Generates error per channel when the operation count exceeds the set value. *3	Enable	Generates an error. Val: 1 to 65000 *4		△ *5	○
			Disable	Does not generate an error.	○		

\*1: Disconnection detection is a function only available for digital unit (EX600-DXPC1, EX600-DXNC1) with disconnection detection.

\*2: 2-wire type input device cannot be correctly detected if its leakage current is 0.5 mA or less while the equipment is in the OFF state (Reed sensor, etc.). Ensure that all input device used has a leakage current above 0.5 mA in the OFF state.

3-wire type input device cannot be correctly detected if its current consumption is 0.5mA or less. The open circuit of input signals cannot be detected.

\*3: The count is memorized every hour. When the power supply is turned on again, counting starts from the last value memorized.

\*4: Times for setting is set value x1000 times.

\*5: It is possible to set it only with DeviceNet™ extended object library 2.

•Digital output unit parameters

No.	Parameter (H.T. Symbol)	Definition	Item	Content	Default setting	Parameter setting	
						By EDS	By H.T.
1	Output load short circuit detection (SC_MonOp)	Generates error per unit when the short circuit of the output device is detected. *1	Enable	Generates an error.	○	○	○
			Disable	Does not generate an error.			
2	Restart after output load short circuit (SC_RstOp)	Restore the setting of short circuit detection error per unit after the output device short circuit is cleared.	Auto	Error is automatically cleared when the short circuit is fixed.	○	○	○
			Manual	Even when the short circuit is fixed, error is not cleared until the power is supplied again.			
3	Open circuit detection (OC_Mon)	Generates error per channel when the disconnection of the output device is detected.	Enable	Generates an error.		Δ *6	○
			Disable	Does not generate an error.	○		
4	Output setting during communication fault *2 (Fault_MD)	Set output per channel when communication is abnormal.	Clear	Turn off the output.	○	Δ *6	○
			Hold	Hold the output.			
			ForceON	Turn on the output forcefully.			
5	Output setting during communication idling *2 *3 (Idle_MD)	Set output per channel during communication idling.	Clear	Turn off the output.	○	Δ *6	○
			Hold	Hold the output.			
			ForceON	Turn on the output forcefully.			
6	Output ON/OFF counter (Counter)	Memorizes the number of times the output device is ON. Generates error per channel when the operation count exceeds the set value. *5	Enable	Generates an error. Val: 1 to 65000 *5		Δ *6	○
			Disable	Does not generate an error.	○		

\*1: Could be incorrectly recognized as short circuit depending on used load (ex.: lamp load). If detection is incorrect, disable the parameter setting.

\*2: This function is valid only when "Hold/Clear priority" of the system parameter is set to H.T.

\*3: Some PLC does not support an idle mode.

\*4: The count is memorized every hour. When the power supply is turned on again, counting starts from the last value memorized.

\*5: Times for setting is set value x1000 times.

\*6: It is possible to set it only with DeviceNet™ extended object library 2.

•Digital I/O unit parameters

No.	Parameter (H.T. Symbol)	Definition	Item	Content	Default setting	Parameter setting	
						By EDS	By H.T.
1	The power supply short circuit detection for control and input (SC_MonSs)	Generates error per unit when the short circuit of the control and input power supply is detected.	Enable	Generates an error.	○	○	○
			Disable	Does not generate an error.			
2	Inrush current filter (Inrush)	Ignores excess current per unit for 100 msec. after inrush.	Enable	Ignores excess current.		○	○
			Disable	Does not ignore excess current	○		
3	Input filtering time (Filter_T)	Sets the time to ignore the input signal change per unit	0.1 ms	Selects the time for filtering.	1.0 ms	○	○
			1.0 ms				
			10 ms				
			20 ms				
4	Input extension time (SigExt_T)	Sets the time to hold the input signal per unit.	1.0 ms	Selects the time to hold the input signal.	15 ms	○	○
			15 ms				
			100 ms				
			200 ms				
5	Output load short circuit detection (SC_MonOp)	Generates error per unit when the short circuit of the output device is detected. *1	Enable	Generates an error.	○	○	○
			Disable	Does not generate an error.			
6	Restart after output load short circuit (SC_RstOp)	Restore the setting of short circuit detection error per unit after the output device short circuit is cleared.	Auto	Error is automatically cleared when the short circuit is fixed.	○	○	○
			Manual	Even when the short circuit is fixed, error is not cleared until the power is supplied again.			
7	Open circuit detection (OC_Mon)	Generates error per channel when the disconnection of the output device is detected.	Enable	Generates an error.		△ *6	○
			Disable	Does not generate an error.	○		
8	Output setting during communication fault *2 (Fault_MD)	Set output per channel when communication is abnormal.	Clear	Turn off the output.	○	△ *6	○
			Hold	Hold the output.			
			ForceON	Turn on the output forcefully.			
9	Output setting for communication idling *2 *3 (Idle_MD)	Set output per channel during communication idling.	Clear	Turn off the output.	○	△ *6	○
			Hold	Hold the output.			
			ForceON	Turn on the output forcefully.			

No.	Parameter (H.T. Symbol)	Definition	Item	Content	Default setting	Parameter setting	
						By EDS	By H.T.
10	Input or Output ON/OFF counter (Counter)	Memorizes the number of times the input or output device is ON. Generates error per channel when the operation count exceeds the set value. *4	Enable	Generates an error. Val: 1 to 65000 *5		Δ *6	○
			Disable	Does not generate an error.	○		

\*1: Could be incorrectly recognized as short circuit depending on used load (ex.: lamp load). If detection is incorrect, disable the parameter setting.

\*2: This function is valid only when "Hold/Clear priority" of the system parameter is set to H.T.

\*3: Some PLC does not support an idle mode.

\*4: The count is memorized every hour. When the power supply is turned on again, counting starts from the last value memorized.

\*5: Times for setting is set value x1000 times.

\*6: It is possible to set it only with DeviceNet™ extended object library 2.

•Analog input unit parameters

No.	Parameter (H.T. Symbol)	Definition	Item	Content	Default setting	Parameter setting	
						By EDS	By H.T.
1	The power supply short circuit detection for the input device (SC_MonSs)	Generates error per unit when the short circuit of the power supply for the input device is detected.	Enable	Generates an error.	○	○	○
			Disable	Does not generate an error.			
2	Analog input range (Range)	Set the analog input device range per channel.	-10..10 V	Selects the analog input range.	-10..10 V	○	○
			-5..5 V				
			-20..20 mA				
			0..10 V				
			0.5 V				
			1..5 V				
			0..20 mA				
4..20 mA							
3	Analog data format (D_Format)	Sets analog data type which is output to PLC per unit.	Offset binary	Offset binary.	○	○	○
			Sign & Magnitude	Signed binary.			
			2s complement	2's complement.			
4	Analog average filter (Filter)	Sets analog filtering time per channel. Sampling interval is approx. 2 sec.	None	None.		○	○
			2AVG	2 value average.	○		
			4AVG	4 value average.			
			8AVG	8 value average.			
5	Over range detection (Over_Rng)	Generates error per unit when the input value exceeds 0.5% of full span.	Enable	Generates an error.	○	○	○
			Disable	Does not generate an error.			
6	Under range detection (Undr_Rng)	Generates error per unit when the input value falls below 0.5% of full span.	Enable	Generates an error.	○	○	○
			Disable	Does not generate an error.			
7	User setting value upper limit error (Upr_Lmt)	Generates error per unit when the input value exceeds the set value.	Enable	Generates an error. *1		△ *2	○
			Disable	Does not generate an error.	○		
8	User setting value lower limit error (Lwr_Lmt)	Generates error per channel when the input value falls below the set value.	Enable	Generates an error. *1		△ *2	○
			Disable	Does not generate an error.	○		

\*1: Set value shall be set per analog input range within settable range in the table below. When the analog input range is changed, check the set value and change it to an appropriate value.

\*2: It is possible to set it only with DeviceNet™ extended object library 2.

Analog input measurement range. (Range)	Upper and lower setting limit of user setting	
	(Lwr_Lmt)	(Upr_Lmt)
-10..10 V	-10.50 to +10.45 V	-10.45 to +10.50 V
-5..5 V	- 5.25 to + 5.22 V	- 5.22 to +5.25 V
-20..20 mA	-21.00 to +20.90 mA	-20.90 to +21.00 mA
0..10 V	0.00 to +10.45 V	+0.05 to +10.50 V
0..5 V	0.00 to +5.22 V	+0.03 to +5.25 V
1..5 V	+0.75 to +5.22 V	+0.78 to +5.25 V
0..20 mA	0.00 to +20.90 mA	+0.10 to +21.00 mA
4..20 mA	+3.00 to +20.90 mA	+3.10 to +21.00 mA

•Analog output unit parameters (1)

No.	Parameter (H.T. Symbol)	Definition	Item	Content	Default setting	Parameter setting	
						By EDS	By H.T.
1	The power supply short circuit detection for the output device (SC_MonSs)	Generates error per unit when the short circuit of the output device is detected.	Enable	Generates an error.	○	○	○
			Disable	Does not generate an error.			
2	Analog output range (Range)	Sets the range of the analog output device per channel.	0..10 V	Selects the analog output range.	0..10 V	○	○
			0..5 V				
			1..5 V				
			0..20 mA				
3	Analog data format (D_Format)	Sets analog data type which is output to PLC per unit.	Offset binary	Offset binary.	○	○	○
			Sign & Magnitude	Signed binary.			
			2s complement	2's complement.			
			Scaled	Scale conversion type.			
4	User setting value upper limit error (Upr_Lmt)	Generates error per channel when the output value exceeds the set value.	Enable	Generates an error. *2		△ *5	○
	Disable	Does not generate an error.	○				
4	Scale upper limit setting *1 (UpLm/Scl)	Sets the scale upper limit. Generates error per channel when the output value exceeds the upper limit.	Enable	Generates an error. Val: -32766 to 32767		○	○
			Disable	Does not generate an error. Val: -32766 to 32767	○ Val: 1000		
5	User setting value lower limit error (Lwr_Lmt)	Generates error per channel when the output value falls below the set value.	Enable	Generates an error. *2		△ *5	○
	Disable	Does not generate an error.	○				
5	Scale lower limit setting *1 (LwLm/Scl)	Sets the scale lower limit. Generates error per channel when the output value falls below the lower limit.	Enable	Generates an error. Val: -32767 to 32766		○	○
			Disable	Does not generate an error. Val: -32767 to 32766	○ Val: 0		
6	Output setting for communication fault *3 (Fault_MA)	Set output per channel when communication is abnormal.	Enable	Output will be user fault value. *2		△ *5	○
			Disable	Output will be held last state.	○		

•Analog output unit parameters (2)

No.	Parameter (H.T. Symbol)	Definition	Item	Content	Default setting	Parameter setting	
						By EDS	By H.T.
7	Output setting for communication idling *3 *4 (Idle_MA)	Set output per channel during communication idling.	Enable	Output will be user idle value. *2		Δ *5	○
			Disable	Output will be held last state.	○		

\*1: When "Scaled" is selected as the analog data format, the display of H.T. is switched from Upr\_Lmt to UpLm/Scl, from Lwr\_Lmt to LwLm/Scl.

\*2: Set value shall be set per analog input range within settable range in the table below. When the analog input range is changed, check the set value and change it to an appropriate value.

\*3: This function is valid only when "Hold/Clear priority" of the system parameter is set to Handheld

\*4: Some PLC does not support an idle mode.

\*5: It is possible to set it only with DeviceNet™ extended object library 2.

Analog output measurement range. (Range)	Upper and lower setting limit of user setting.		Settable range during communication fault or idling. (Fault_MA) (Idle_MA)
	(Lwr_Lmt)	(Upr_Lmt)	
0..10 V	0.00 to +10.45 V	+0.05 to +10.50 V	0.00 to +10.50 V
0..5 V	0.00 to + 5.22 V	+0.03 to +5.25 V	0.00 to +5.25 V
1..5 V	+0.75 to +5.22 V	+0.78 to +5.25 V	+0.75 to +5.25 V
0..20 mA	0.00 to +20.90 mA	+0.10 to +21.00 mA	0.00 to +21.00 mA
4..20 mA	+3.00 to +20.90 mA	+3.10 to +21.00 mA	+3.00 to +21.00 mA

•Analog I/O unit parameters (1)

No.	Parameter (H.T. Symbol)	Definition	Item	Content	Default setting	Parameter setting	
						By EDS	By H.T.
1	The power supply short circuit detection for the input or output device (SC_MonSs)	Generates error per unit when the short circuit of the input device power supply or output device is detected.	Enable	Generates an error.	○	○	○
			Disable	Does not generate an error.			
2	Analog input or output range (Range)	Sets the analog input or output device range per channel.	0..10 V	Selects the analog input or output range.	1.5 V	○	○
			0..5 V				
			1..5 V				
			0..20 mA				
			4..20 mA				
3	Analog data format (D_Format)	Sets analog data type which is output to PLC per unit.	Offset binary	Offset binary.	○	○	○
			Sign & Magnitude	Signed binary.			
			2s complement	2's complement.			
			Scaled	Scale conversion type.			
4	Analog average filter (Filter)	Sets analog filtering time per channel. Sampling interval is approx. 2 sec.	None	None.		○	○
			2AVG	2 value average.	○		
			4AVG	4 value average.			
			8AVG	8 value average.			
5	Over range detection (Over_Rng)	Generates error per unit when the input value exceeds 0.5% of full span.	Enable	Generates an error.		○	○
			Disable	Does not generate an error.	○		
6	Under range detection (Undr_Rng)	Generates error per unit when the input value falls below 0.5% of full span.	Enable	Generates an error.		○	○
			Disable	Does not generate an error.	○		
7	User's set value upper limit error (Upr_Lmt)	Generates error per channel when the input or output value exceeds the set value.	Enable	Generates an error. *2		△ *5	○
			Disable	Does not generate an error.	○		
	Scale upper limit setting *1 (UpLm/Scl)	Sets the scale upper limit. Generates error per channel when the input or output value exceeds the upper limit.	Enable	Generates an error. Val: -32766 to 32767			
			Disable	Does not generated an error. Val: -32766 to 32767	○ Val: 1000		

•Analog I/O unit parameters (2)

No.	Parameter (H.T. Symbol)	Definition	Item	Content	Default setting	Parameter setting	
						By EDS	By H.T.
8	User's set value lower limit error (Lwr_Lmt)	Generates error per channel when the input or output value falls below the set value.	Enable	Generates an error. *2		Δ *5	○
			Disable	Does not generate an error.	○		
	Scale lower limit setting *1 (UpLm/ScI)	Sets the scale lower limit. Generates error per channel when the input or output value falls below the lower limit.	Enable	Generates an error. Val: -32767 to 32766			
			Disable	Does not generate an error. Val: -32767 to 32766	○ Val: 0		
9	Output setting for communication fault *3 (Fault_MA)	Set output per channel when communication is abnormal.	Enable	Output will be user fault value. *2		Δ *5	○
			Disable	Output will be held last state.	○		
10	Output setting for communication idling *3 *4 (Idle_MA)	Sets output per channel during communication idling.	Enable	Output will be user idle value. *2		Δ *5	○
			Disable	Output will be held last state.	○		

\*1: When "Scaled" is selected as the analog data format, the display of H.T. is switched from UpLm\_Lmt to UpLm/ScI, from Lwr\_Lmt to LwLm/ScI.

\*2: Set value shall be set per analog output range within settable range in the table below. When the analog output range is changed, check the set value and change it to an appropriate value.

\*3: This function is valid only when "Hold/Clear priority" of the system parameter is set to H.T.

\*4: Some PLC does not support an idle mode.

\*5: It is possible to set it only with DeviceNet™ extended object library 2.

Analog Input or output measurement range. (Range)	Upper and lower setting limit of user setting.		Settable range during communication fault or idling. (Fault_MA) (Idle_MA)
	(Lwr_Lmt)	(Upr_Lmt)	
0..10 V	0.00 to +10.45 V	+0.05 to +10.50 V	0.00 to +10.50 V
0..5 V	0.00 to +5.22 V	+0.03 to +5.25 V	0.00 to +5.25 V
1..5 V	+0.75 to +5.22 V	+0.78 to +5.25 V	+0.75 to +5.25 V
0..20 mA	0.00 to +20.90 mA	+0.10 to +21.00 mA	0.00 to +21.00 mA
4..20 mA	+3.00 to +20.90 mA	+3.10 to +21.00 mA	+3.00 to +21.00 mA

## Hardware Configuration

### ■ EDS file and icon

EDS file is required to configure the EX600. Furthermore, icons are necessary for the display icon of the EX600 on the configure. The EDS File and icon can be downloaded from the URL given below.

•URL: <http://www.smcworld.com>

Products Document → Instruction Manual → ex600\_sdn1\_v16.zip (EX600-SDN1)  
 ex600\_sdn2\_v16.zip (EX600-SDN2)  
 ex600\_sdn1\_v16.zip (EX600-SDN1A)  
 ex600\_sdn2\_v16.zip (EX600-SDN2A)

•Content of ex600_sdn1_v16.zip	EDS file	ex600_sdn1_v16.eds
	Icon	ex600_1.ico
•Content of ex600_sdn2_v16.zip	EDS file	ex600_sdn2_v16.eds
	Icon	ex600_1.ico
•Content of ex600_sdn1_v22.zip	EDS file	ex600_sdn1_v22.eds
	Icon	ex600_1.ico
•Content of ex600_sdn2_v22.zip	EDS file	ex600_sdn2_v22.eds
	Icon	ex600_1.ico

### •EDS file version

The latest EDS file name is “ex600\_sdn1\_v22.eds“, and “ex600\_sdn2\_v22.eds”.

There are some Units that cannot be configured by “ex600\_sdn1\_v16.eds“, and “ex600\_sdn2\_v16.eds”.

			EDS file name	
			ex600_sdn1_v16.eds ex600_sdn2_v16.eds	ex600_sdn1_v22.eds ex600_sdn2_v22.eds
Product number	SI Unit	EX600-SDN□	○	×
		EX600-SDN□A	×	○
	Digital input unit	EX600-DX□B/□C□/□D	○	○
		EX600-DX□E/□F	×	○
	Disital output unit	EX600-DY□B	○	○
		EX600-DY□E/□F	×	○
	Digital I/O unit	EX600-DM□E/□F	×	○
	Analog input unit	EX600-AXA	○	○
	Analog output unit	EX600-AYA	×	○
	Analog I/O unit	EX600-AMB	×	○

## ■ Setting using RSNetWorx for DeviceNet™

Below is an explanation of the EX600 Series connection method with a Rockwell Automation' DeviceNet™ module.

Refer to the manual of RSNetWorx for DeviceNet™ for a detailed manner of operation.

\*: The screen data shown here is the English version of RSNetWorx for DeviceNet™ verion 5.00.00.

### • EDS file install

- (1) Start RSNetWorx for DeviceNet™.
- (2) Select [EDS Wizard] from [Tools].
- (3) The EDS file and the icon are installed.

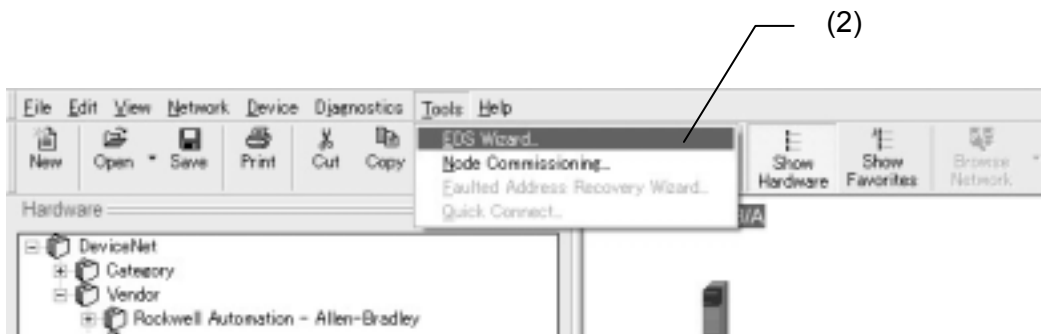

- (4) EX600-SDN□ is registered to the folder of DeviceNet™ ¥Vendor¥SMC Corporation¥Communication Adapter on the [Hardware screen].

Or it is registered to the folder of DeviceNet™ ¥Category¥Communication Adapter.

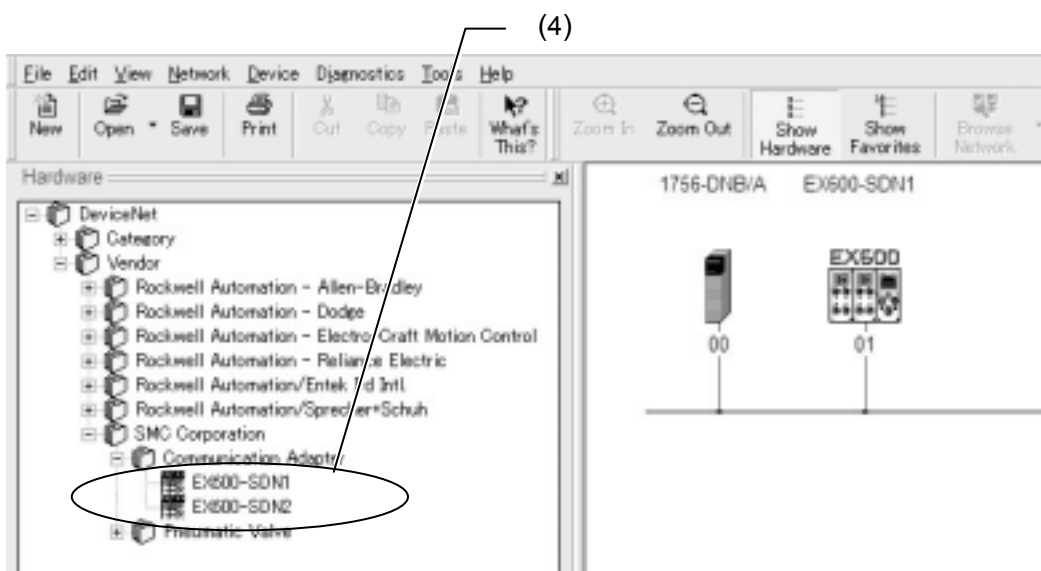

•Registration to the network

- (1) Double click EX600-SDN□ on the [Hardware screen].
- (2) The icon of EX600-SDN□ is displayed on the [Network screen].

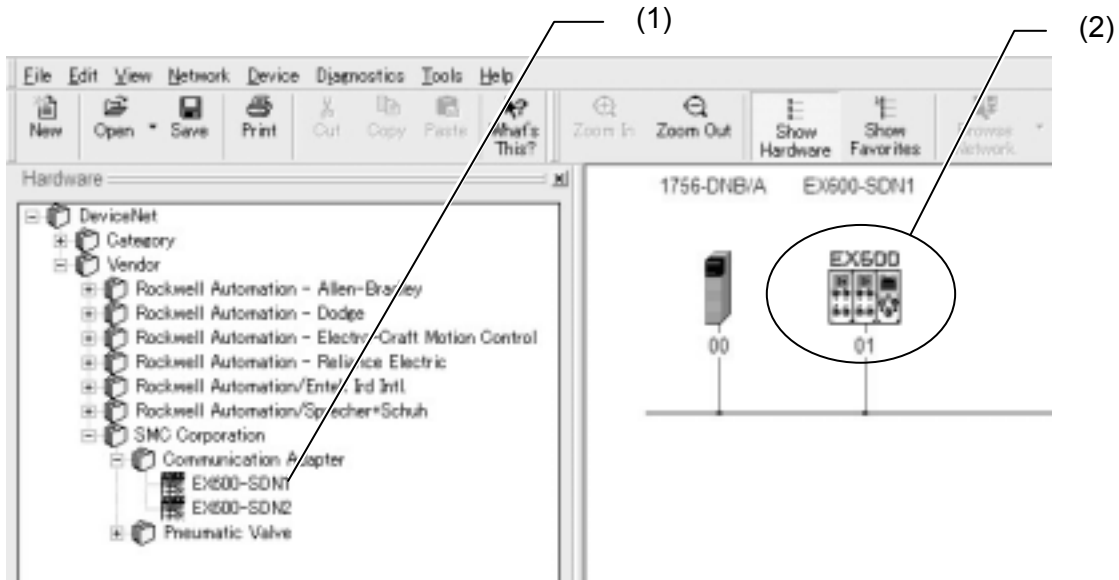

•Address setting of EX600

- (1) Double click EX600-SDN□ on the [Network screen].
- (2) [EX600-SDN□ property screen] is displayed. Input DeviceNet™ address, and click on [OK].

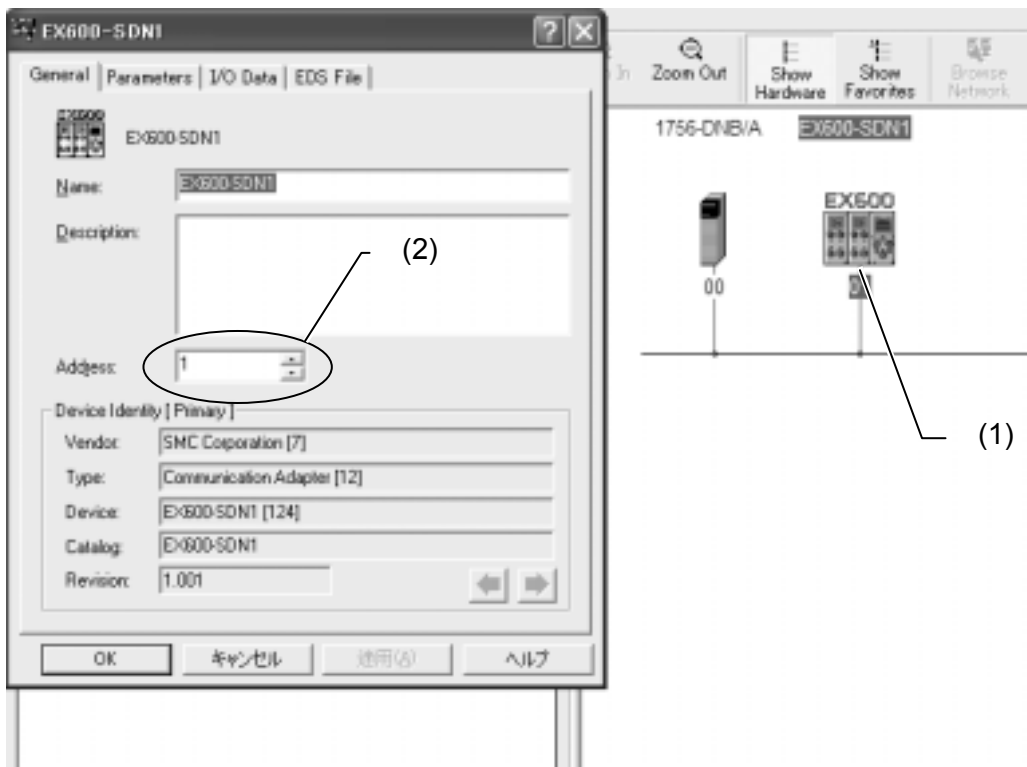

•Setting of the scan list

(1)Double click the scanner icon on the [Network screen].

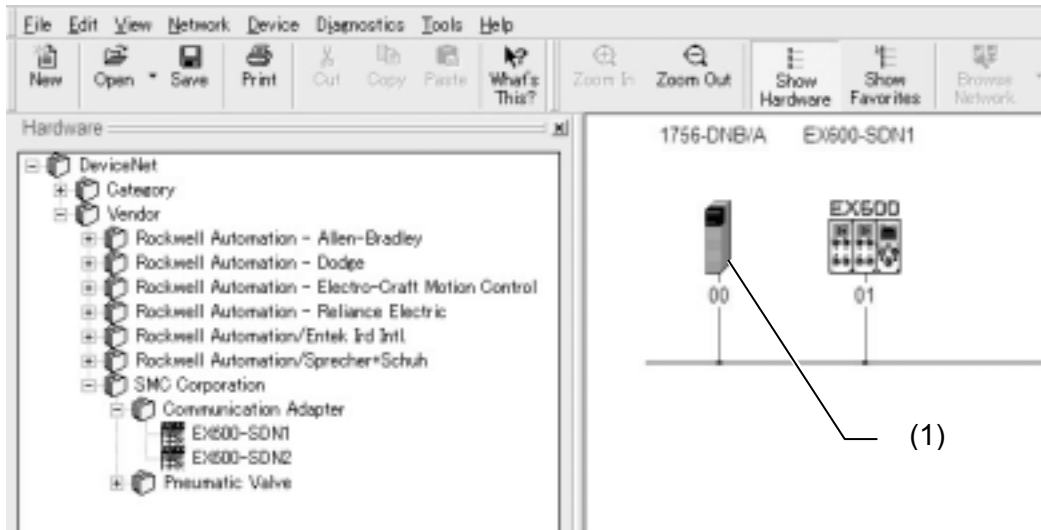

(2)[1756-DNB/A property screen] is displayed. Click the [Scanlist] tab.

(3)Select EX600-SDN□ in [Available Devices;], and click on the [>] button.

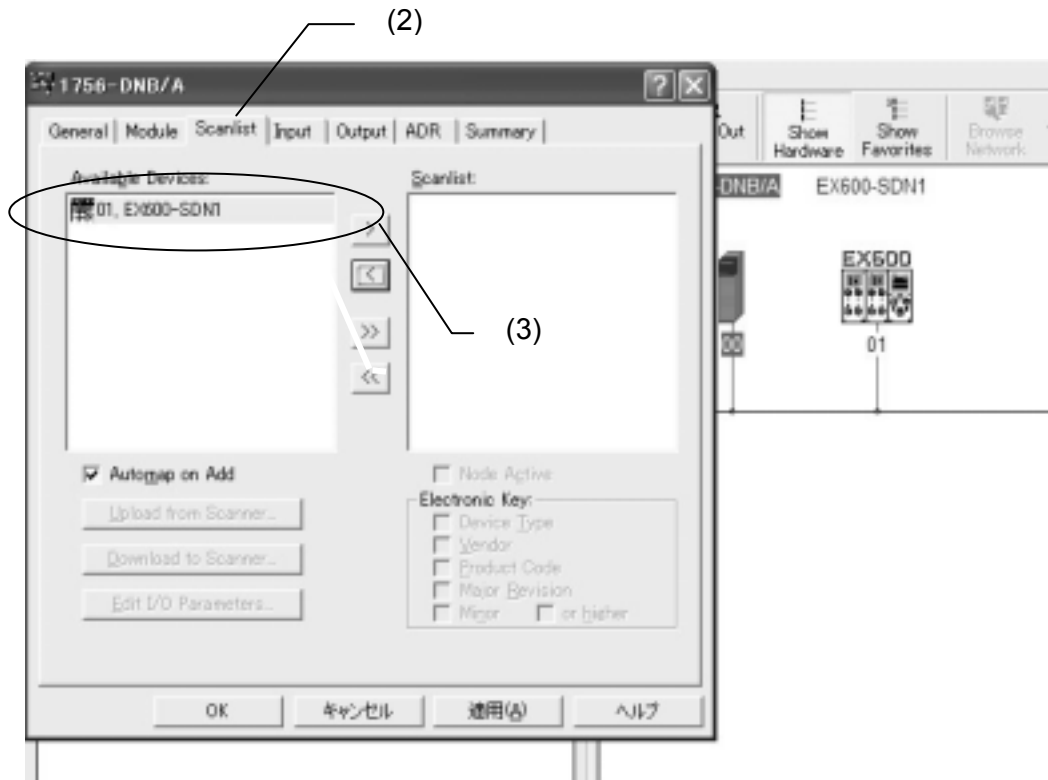

•Setting of I/O parameters

(1) Double click the EX600-SDN□ on the [Scanlist;].

(2) [Edit I/O parameters screen] is displayed. Input I/O Parameters, and click on [OK].

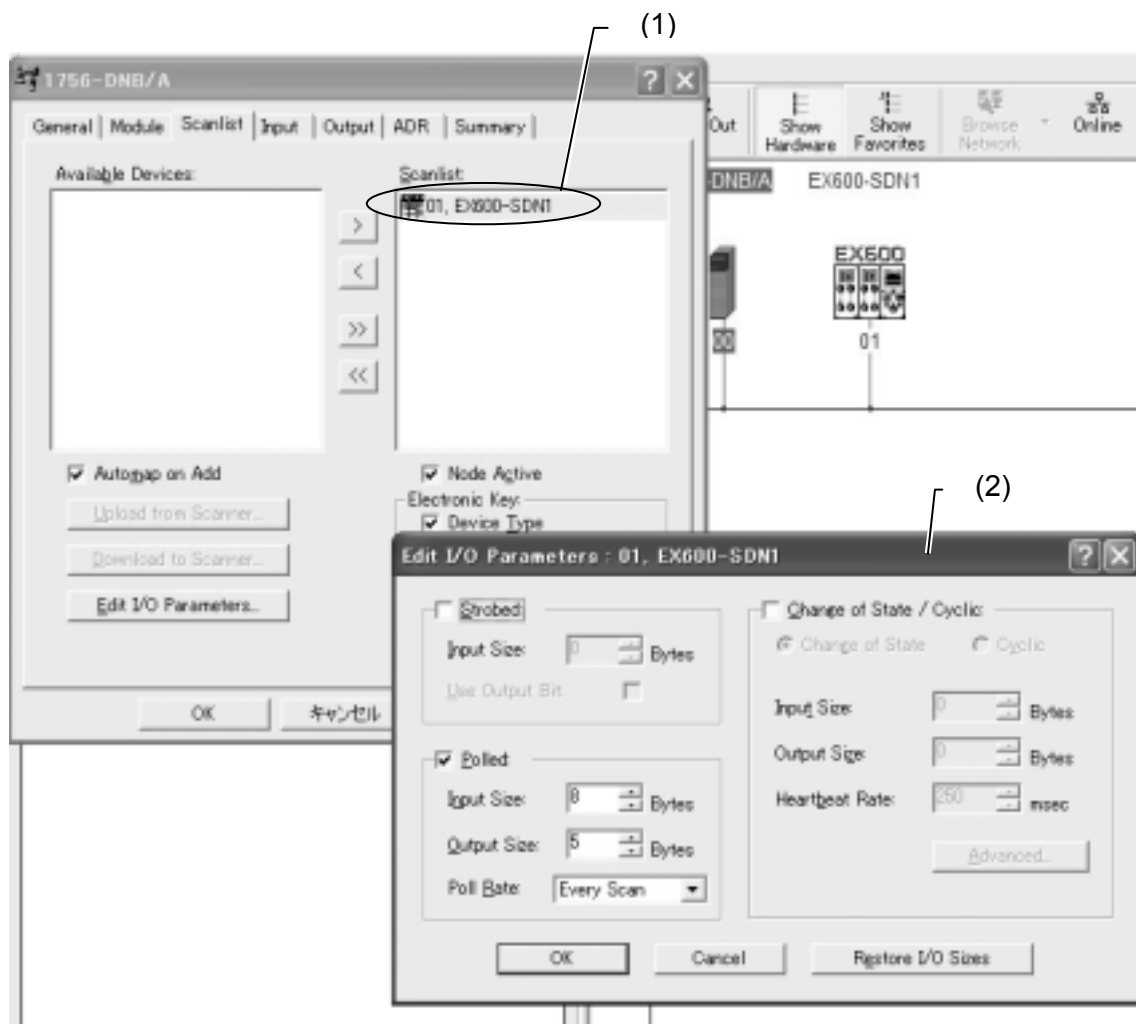

\*: Please leave unticked the "Strobed" and "Change of State/Cyclic" tick boxes. These functions are not supported.

## I/O Map

Each unit of the product has its own.

Unit	Unit part number	Occupied byte	
		Input	Output
SI unit	EX600-SDN□A (32 outputs)	0	4
	EX600-SDN□A (24 outputs)	0	3
	EX600-SDN□A (16 outputs)	0	2
	EX600-SDN□A (8 outputs)	0	1
Digital input unit	EX600-DX□B (8 inputs)	1	0
	EX600-DX□C (8 inputs)	1	0
	EX600-DX□C1 (8 inputs) (With open circuit detection)	1	0
	EX600-DX□D (16 inputs)	2	0
	EX600-DX□E (16 inputs)	2	0
	EX600-DX□F (16 inputs)	2	0
Digital output unit	EX600-DY□B (8 outputs)	0	1
	EX600-DY□E (16 outputs)	0	2
	EX600-DY□E1 (24 outputs)	0	3
	EX600-DY□F (16 outputs)	0	2
Digital I/O unit	EX600-DM□E (8 inputs/8 outputs)	1	1
	EX600-DM□F (8 inputs/8 outputs)	1	1
Analog input unit	EX600-AXA (2 channels)	4 (2 byte/1 channel)	0
Analog output unit	EX600-AYA (2 channels)	0	4 (2 byte/1 channel)
Analog I/O unit	EX600-AMB (2 channels/2 channels)	4 (2 byte/1 channel)	4 (2 byte/1 channel)

## Diagnostic

By changing the diagnostic switch, the diagnostic data shown below is assigned to the head of input data of the input/output map. (Refer to “Setting and adjustment” for setting the switch.)

Mode	Diagnostic Data	Diagnostic Size
0	No diagnostic data.	0 byte
1	System diagnosis	4 byte
2	System diagnosis + Unit diagnosis (Up to 10 units)	6 byte
3	System diagnosis + Unit diagnosis (Up to 64 units)	12 byte

\*: Diagnosis mode 3 is a function for extension in the future. Do not use it now.

\*: Channel diagnosis cannot be assigned to the diagnosis area of the input.

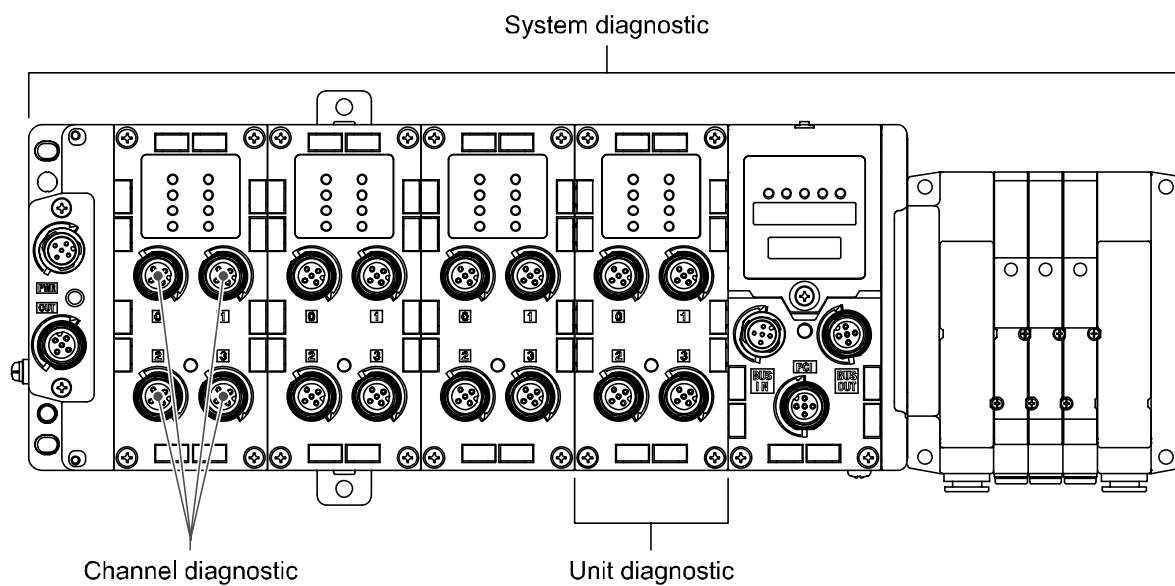

• I/O map assignment

I/O map of EX600 is assigned in order starting from the unit on the end plate side.

Taking the unit layout below as an example, the input/ output map of each diagnosis mode is shown below.

	Unit 0	Unit 1	Unit 2	Unit 3	Unit 4	Unit 5	
End plate	AXA	DY□B	DY□B	DX□B	DX□D	SDN□A	Valve
	Analog input	Digital output	Digital output	Digital input	Digital input	SI unit (32 output)	
	4 byte Input	1 byte Output	1 byte Output	1 byte Input	2 byte Input	4 byte Output	

Input data: Analog input unit (EX600-AXA)\_4 byte occupied (Unit 0)

Digital input unit (EX600-DX□B)\_1 byte occupied (Unit 3)

Digital input unit (EX600-DX□D)\_2 byte occupied (Unit 4)

Output data: Digital output unit(EX600-DY□B)\_1 byte occupied (Unit 1)

Digital output unit (EX600-DY□B)\_1 byte occupied (Unit 2)

SI unit (EX600-SDN□A)\_4 byte occupied (Unit 5)

• Diagnostic mode 0

	Input data	Output data
Byte0	AXA channel 0 (Unit 0)	DY□B (Unit 1)
Byte1		DY□B (Unit 2)
Byte2	AXA channel 1 (Unit 0)	SDN□A (Unit 5)
Byte3		
Byte4		
Byte5	DX□B (Unit 3)	
Byte6	DX□D (Unit 4)	
Total	7 byte	6 byte

•Diagnostic mode 1

	Input data	Output data	
Byte0	System diagnosis byte0	DY□B (Unit 1)	
Byte1	System diagnosis byte1	DY□B (Unit 2)	
Byte2	System diagnosis byte2	SDN□A (Unit 5)	
Byte3	System diagnosis byte3		
Byte4	AXA channel 0 (Unit 0)		
Byte5			
Byte6	AXA channel 1 (Unit 0)	/	
Byte7			
Byte8	DX□B (Unit 3)		
Byte9	DX□D (Unit 4)		
Byte10			
Total	11 byte		6 byte

•Diagnostic mode 2

	Input data	Output data	
Byte0	System diagnosis byte0	DY□B (Unit 1)	
Byte1	System diagnosis byte1	DY□B (Unit 2)	
Byte2	System diagnosis byte2	SDN□A (Unit 5)	
Byte3	System diagnosis byte3		
Byte4	Unit diagnosis byte0		
Byte5	Unit diagnosis byte1	/	
Byte6	AXA channel 0 (Unit 0)		
Byte7			
Byte8	AXA channel 1 (Unit 0)		
Byte9			
Byte10	DX□B (Unit 3)		
Byte11	DX□D (Unit 4)		
Byte12			
Total	13 byte		6 byte

## ■Details of diagnostic data

### •System diagnosis

#### •System diagnosis byte0

Bit No.	Content of diagnosis
0	The analog value has fallen below the user's set value.
1	The analog value has exceeded the user's set value.
2	The analog input value has fallen below the set range.
3	The analog input value has exceeded the set range.
4	The counter has exceeded the set value.
5	The open circuit has been detected.
6	The short circuit of the valve output or digital output has been detected.
7	The short circuit of the power supply for the input/output device has been detected.

#### •System diagnosis byte1

Bit No.	Content of diagnosis
0	The power supply voltage for output device is outside of the specification.
1	The power supply voltage for control and input device is outside of the specification.
2	Reserved
3	There is a connection failure between each unit (During operation).
4	There is a connection failure between each unit (When the power supply is applied).
5	Configuration memory error occurred.
6	System error occurred.
7	Hardware error occurred.

#### •System diagnosis byte2

Bit No.	Content of diagnosis
0	Reserved
:	:
7	Reserved

#### •System diagnosis byte3

Bit No.	Content of diagnosis
0	There is an error in the digital input unit. *1
1	There is an error in the digital output unit. *1
2	There is an error in the analog input unit. *2
3	There is an error in the analog output unit. *2
4	There is an error in the SI unit.
5	Reserved
6	Reserved
7	Reserved

\*1: When the error occurs in the digital I/O unit, both Bit0 and Bit1 are turned on.

\*2: When the error occurs in the analog I/O unit, both Bit2 and Bit3 are turned on.

•Unit diagnosis

•Unit diagnosis byte0

Bit No.	Content of diagnosis
0	There is an error in unit 0.
1	There is an error in unit 1.
2	There is an error in unit 2.
3	There is an error in unit 3.
4	There is an error in unit 4.
5	There is an error in unit 5.
6	There is an error in unit 6.
7	There is an error in unit 7.

•Unit diagnosis byte1

Bit No.	Content of diagnosis
0	There is an error in unit 8.
1	There is an error in unit 9.
2	Reserved
3	Reserved
4	Reserved
5	Reserved
6	Reserved
7	Reserved

# DeviceNet™ Object

The EX600 series supports the object classes below.

Classification	Object	Class	Instance
DeviceNet™ object	Identity	01h	01h
	Message Router	02h	01h
	DeviceNet™ *1	03h	01h
	Connection	05h	03h
	Register	07h	02h
	Acknowledge Handler	2Bh	01h
DeviceNet™ extended object library 1	Map	65h	01h
	System	66h	01h
	Digital Input Unit	6Ah	01h to 40h *2
	Digital Output Unit	6Bh	01h to 40h *2
	SI Unit	6Ch	01h to 10h *2
	Analog Input Unit	6Dh	01h to 10h *2
	Analog Input/Output Unit	6Fh	01h to 10h *2
	Digital Input/Output Unit	70h	01h to 40h *2
DeviceNet™ extended object library 2	Analog Output Unit	71h	01h to 10h *2
	System information	66h	01h
	Unit/channel diagnosis	67h	01h to 0Ah *3
	Details of channel diagnosis	77h	01h to 0Ah *3
	Unit parameter	78h	01h to 0Ah *3
	Channel parameter (1)	79h to 7Fh	01h to 0Ah *3
	Channel parameter (2)	83h to 8Ah	01h to 0Ah *3

\*1: It corresponds to a Quick Connect. [Attribute: 0Ah]

\*2: The number assigned from the end plate side of the same unit type.

\*3: The number assigned from the end plate side regardless of the unit type.

For the unit configuration below, the instance of unit 2 becomes 02h in case of \*1.

The instance of unit 2 becomes 03h in case of \*2.

	Unit 0	Unit 1	Unit 2	Unit 3	Unit 4	Unit 5	
End Plate	AXA Analog input	DY□B Digital output	DY□B Digital output	DX□B Digital input	DX□D Digital input	SDN□A SI unit (32 output)	Valve
Instance *1	01h	01h	02h	01h	02h	01h	
Instance *2	01h	02h	03h	04h	05h	06h	

•Map object (Class:65h) [DeviceNet™ extended object library 1]

Instance	Attribute	Access	Name	Type	Description/Value
01h	64h	Get	Input Data Size	UINT	Input data length
	65h	Get	Output Data Size	UINT	Output data length

•System object (Class:66h) [DeviceNet™ extended object library 1]

Instance	Attribute	Access	Name	Type	Description/Value
01h	69h	Get	System Status 1	UINT	Bit0: Monitoring the power supply voltage (For output) Bit1: Monitoring the power supply voltage (For control and input) Bit2: Reserved Bit3: Unit not connected Bit4: Connection error Bit5: Configuration memory error Bit6: System error Bit7: Hardware error Bit8: Analog user set value lower limit detection Bit9: Analog user set value upper limit detection Bit10: Analog range lower limit detection Bit11: Analog range upper limit detection Bit12: Contact frequency upper limit detection Bit13: Open circuit detection Bit14: Short circuit detection (Output) Bit15: Short circuit detection (Power supply for input/output device)
	6Ah	Get	System Status 2	UINT	Bit0: Digital input unit error Bit1: Digital output unit error Bit2: Analog input unit error Bit3: Analog output unit error Bit4: SI unit error Bit5: Reserved Bit6: Reserved Bit7: Reserved Bit8: Reserved Bit9: Reserved Bit10: Reserved Bit11: Reserved Bit12: Reserved Bit13: Reserved Bit14: Reserved Bit15: Reserved

•System object (Class:66h) [DeviceNet™ extended object library 1]

Instance	Attribute	Access	Name	Type	Description/Value
01h	6Dh	Get	Number of units	USINT	Number of units connected
	94h	Get	Unit Diagnostics 1	WORD	Bit0: Error is detected in unit 0 Bit1: Error is detected in unit 1 Bit2: Error is detected in unit 2 Bit3: Error is detected in unit 3 Bit4: Error is detected in unit 4 Bit5: Error is detected in unit 5 Bit6: Error is detected in unit 6 Bit7: Error is detected in unit 7 Bit8: Error is detected in unit 8 Bit9: Error is detected in unit 9 Bit10: Reserved Bit11: Reserved Bit12: Reserved Bit13: Reserved Bit14: Reserved Bit15: Reserved
	95h	Get	Unit Diagnostics 2	WORD	Reserved
	96h	Get	Unit Diagnostics 3	WORD	Reserved
	97h	Get	Unit Diagnostics 4	WORD	Reserved
	98h	Get	Unit Connection 1	WORD	Bit0: Recognition of unit 0 Bit1: Recognition of unit 1 Bit2: Recognition of unit 2 Bit3: Recognition of unit 3 Bit4: Recognition of unit 4 Bit5: Recognition of unit 5 Bit6: Recognition of unit 6 Bit7: Recognition of unit 7 Bit8: Recognition of unit 8 Bit9: Recognition of unit 9 Bit10: Reserved Bit11: Reserved Bit12: Reserved Bit13: Reserved Bit14: Reserved Bit15: Reserved
	99h	Get	Unit Connection 2	WORD	Reserved
	9Ah	Get	Unit Connection 3	WORD	Reserved
	9Bh	Get	Unit Connection 4	WORD	Reserved
	79h	Get/Set	Hold/Clear	BOOL	0=Switch 1=H.T. or DeviceNet™ Object

•Digital Input Unit object (Class:6Ah) [DeviceNet™ extended object library 1]

Instance	Attribute	Access	Name	Type	Value
01h to 40h	70h	Get/Set	Monitoring short circuit at Power Supply	BOOL	0=Disable 1=Enable
	78h	Get/Set	Inrush current detection	BOOL	0=Disable 1=Enable
	A4h	Get/Set	Input filtering time	USINT	0=0.1 ms 1=1.0 ms 2=10 ms 3=20 ms
	A8h	Get/Set	Input extension time	USINT	0=1.0 ms 1=15 ms 2=100 ms 3=200 ms

•Digital Output Unit object (Class:6Bh) [DeviceNet™ extended object library 1]

Instance	Attribute	Access	Name	Type	Value
01h to 40h	71h	Get/Set	Monitoring short circuit at Output	BOOL	0=Disable 1=Enable
	7Bh	Get/Set	Restart after short circuit	BOOL	0=Manual 1=Auto

•SI Unit object (Class:6Ch) [DeviceNet™ extended object library 1]

Instance	Attribute	Access	Name	Type	Value
01h to 10h	71h	Get/Set	Monitor short circuit at Output	BOOL	0=Disable 1=Enable
	7Bh	Get/Set	Restart after short circuit	BOOL	0=Manual 1=Auto
	ACh	Get/Set	Control power supply voltage monitor	BOOL	0=Disable 1=Enable
	ADh	Get/Set	Output power supply voltage monitor	BOOL	0=Disable 1=Enable

•Analog Input Unit object (Class:6Dh) [DeviceNet™ extended object library 1]

Instance	Attribute	Access	Name	Type	Value
01h to 10h	70h	Get/Set	Monitor short circuit at Power Supply	BOOL	0=Disable 1=Enable
	74h	Get/Set	Monitor over range	BOOL	0=Disable 1=Enable
	75h	Get/Set	Monitor under range	BOOL	0=Disable 1=Enable
	A4h	Get/Set	Ch0 analog input filter	USINT	0=None 1=2 value average 2=4 value average 3=8 value average
	A5h	Get/Set	Ch1 analog input filter	USINT	0=None 1=2 value average 2=4 value average 3=8 value average
	A8h	Get/Set	Ch0 analog range	USINT	0=-10...+10 V 1=-5...+5 V 2=-20...+20 mA 3=0...10 V 4=0...5 V 5=1...5 V 6=0...20 mA 7=4...20 mA
	A9h	Get/Set	Ch1 analog range	USINT	0=-10...+10 V 1=-5...+5 V 2=-20...+20 mA 3=0...10 V 4=0...5 V 5=1...5 V 6=0...20 mA 7=4...20 mA
	ACh	Get/Set	Analog data format	USINT	0=Offset Binary 1=Sign & Magnitude 2=2's complement

•Analog Input/Output Unit object (Class:6Fh) [DeviceNet™ extended object library 1]

Instance	Attribute	Access	Name	Type	Value
01h to 10h	70h	Get/Set	Monitor short circuit at Power Supply	BOOL	0=Disable 1=Enable
	74h	Get/Set	Monitor over range	BOOL	0=Disable 1=Enable
	75h	Get/Set	Monitor under range	BOOL	0=Disable 1=Enable
	A4h	Get/Set	I-Ch0 analog input filter	USINT	0=None 1=2 value average 2=4 value average 3=8 value average
	A5h	Get/Set	I-Ch1 analog input filter	USINT	0=None 1=2 value average 2=4 value average 3=8 value average
	A8h	Get/Set	I-Ch0 analog range	USINT	3=0...10 V 4=0...5 V 5=1...5 V 6=0...20 mA 7=4...20 mA
	A9h	Get/Set	I-Ch1 analog range	USINT	3=0...10 V 4=0...5 V 5=1...5 V 6=0...20 mA 7=4...20 mA
	AAh	Get/Set	O-Ch0 analog range	USINT	3=0...10 V 4=0...5 V 5=1...5 V 6=0...20 mA 7=4...20 mA
	ABh	Get/Set	O-Ch1 analog range	USINT	3=0...10 V 4=0...5 V 5=1...5 V 6=0...20 mA 7=4...20 mA
	ACh	Get/Set	Analog data format	USINT	0=Offset Binary 1=Sign and Magnitude 2=2's complement 3= Scaled

•Digital Input/Output Unit object (Class:70 h) [DeviceNet™ extended object library 1]

Instance	Attribute	Access	Name	Type	Value
01h to 40h	70h	Get/Set	Monitoring short circuit at Power Supply	BOOL	0=Disable 1=Enable
	71h	Get/Set	Monitoring short circuit at Output	BOOL	0=Disable 1=Enable
	78h	Get/Set	Inrush current detection	BOOL	0=Disable 1=Enable
	7Bh	Get/Set	Restart after short circuit	BOOL	0=Manual 1=Auto
	A4h	Get/Set	Input filtering time	USINT	0=0.1 ms 1=1.0 ms 2=10 ms 3=20 ms
	A8h	Get/Set	Input extension time	USINT	0=1.0 ms 1=15 ms 2=100 ms 3=200 ms

•Analog Output Unit object (Class:71 h) [DeviceNet™ extended object library 1]

Instance	Attribute	Access	Name	Type	Value
01h to 10h	70h	Get/Set	Monitor short circuit at Power Supply	BOOL	0=Disable 1=Enable
	A8h	Get/Set	Ch0 analog range	USINT	3=0...10 V 4=0...5 V 5=1...5 V 6=0...20 mA 7=4...20 mA
	A9h	Get/Set	Ch1 analog range	USINT	3=0...10 V 4=0...5 V 5=1...5 V 6=0...20 mA 7=4...20 mA
	ACh	Get/Set	Analog data format	USINT	0=Offset Binary 1=Sign and Magnitude 2=2's complement 3=Scaled

•System information (class: 66h) [DeviceNet™ extended object library 2]

Instance	Attribute	Access	Name	type	Value
01h	64h	Get	Input data length	UINT	I/O mapping input data length (byte)
	65h	Get	Output data length	UINT	I/O mapping output data length (byte)
	6Dh	Get	Number of units connected	USINT	Number of units connected
	79h	Get/Set	Hold/Clear	BOOL	0: switch 1: H.T. or DeviceNet™ object
	7Ah	Get	System diagnosis 1	BYTE	Bit0: Analog user set value lower limit detection Bit1: Analog user set value upper limit detection Bit2: Analog range lower limit detection Bit3: Analog range upper limit detection Bit4: ON/OFF count upper limit detection Bit5: Open circuit detection Bit6: Short circuit detection (Output) Bit7: Short circuit detection (Power supply for input device)
	7Bh	Get	System diagnosis 2	BYTE	Bit0: Monitoring the power supply voltage (For output) Bit1: Monitoring the power supply voltage (For control and input) Bit2: Reserved Bit3: Number of units not connected Bit4: System connection error Bit5: Configuration error Bit6: System default error Bit7: Hardware error
	7Dh	Get	System diagnosis 3	BYTE	Bit0: Digital input unit error Bit1: Digital output unit error Bit2: Analog input unit error Bit3: Analog output unit error Bit4: SI unit error Bit5: Reserved : Bit7: Reserved
	9Ch	Get	Unit operating condition 1	BYTE	Bit0: Error is detected in unit 0 : Bit1: Error is detected in unit 7
	9Dh	Get	Unit operating condition 2	BYTE	Bit0: Error is detected in unit 8 Bit1: Error is detected in unit 9 Bit2: Reserved : Bit7: Reserved
	A Eh	Get	Unit operating condition 1	BYTE	Bit0: Unit 0 is recognized : Bit7: Unit 7 is recognized
A Fh	Get	Unit operating condition 2	BYTE	Bit0: Unit 8 is recognized Bit1: Unit 9 is recognized Bit2: Reserved : Bit7: Reserved	

•Unit/Channel diagnosis object (Class: 67h) [DeviceNet™ extended object library 2]

Instance	Attribute	Access	Name	Type	Value
01h to 0Ah *1	6Ch	Get	Unit diagnosis	BYTE	Bit0: Analog user set value lower limit detection Bit1: Analog user set value upper limit detection Bit2: Analog range lower limit detection Bit3: Analog range upper limit detection Bit4: Contact frequency upper limit detection Bit5: Open circuit detection Bit6: Short circuit detection (Output) Bit7: Short circuit detection (Power supply for input/output device)
	6Eh	Get	Channel diagnosis Ch0 to Ch7	BYTE	Bit0: Error is detected in channel 0 : Bit7: Error is detected in channel 7
	6Fh	Get	Channel diagnosis Ch8 to Ch15	BYTE	Bit0: Error is detected in channel 8 : Bit7: Error is detected in channel 15
	70h	Get	Channel diagnosis Ch16 to Ch23	BYTE	Bit0: Error is detected in channel 16 : Bit7: Error is detected in channel 23
	71h	Get	Channel diagnosis Ch24 to Ch31	BYTE	Bit0: Error is detected in channel 24 : Bit7: Error is detected in channel 31

\*1: 01h to 0Ah indicates the unit number 0 to 9.

•Details of channel diagnosis object (Class: 77h) [DeviceNet™ extended object library 2]

Instance	Attribute	Access	Name	Type	Value
01h to 0Ah *1	64h to 83h *2	Get	Channel diagnosis Ch0 to 31	BYTE	Bit0: Analog user set value lower limit detection Bit1: Analog user set value upper limit detection Bit2: Analog range lower limit detection Bit3: Analog range upper limit detection Bit4: Contact frequency upper limit detection Bit5: Open circuit detection Bit6: Short circuit detection (Output) Bit7: Short circuit detection (Power supply for input/output device)

\*1: 01h to 0Ah indicates the unit number 0 to 9.

\*2: 64h to 83h indicates the channel number 0 to 31.

•Unit parameter object (Class: 78h) [DeviceNet™ extended object library 2]

Instance	Attribute	Access	Name	Type	Value
01h to 0Ah *1	64h	Get/Set	Short circuit detection (Power supply for input device) •Digital I, I/O •Analog I, O, I/O	BOOL	0=Disable 1=Enable
	65h	Get/Set	Short circuit detection (Output) •SI •Digital O, I/O	BOOL	0=Disable 1=Enable
	66h	Get/Set	Analog range upper limit detection •Analog I, I/O	BOOL	0=Disable 1=Enable
	67h	Get/Set	Analog range lower limit detection •Analog I, I/O	BOOL	0=Disable 1=Enable
	68h	Get/Set	Measure against in-rush current •Digital I, I/O	BOOL	0=Disable 1=Enable
	69h	Get/Set	Recovery after a short circuit •SI •Digital O, I/O	BOOL	0=Manual 1=Auto
	6Ah	Get/Set	Input filtering time •Digital I, I/O	USINT	0=0.1 ms 1=1.0 ms 2=10 ms 3=20 ms
	6Bh	Get/Set	Digital input extension time •Digital I, I/O	USINT	0=1.0 ms 1=15 ms 2=100 ms 3=200 ms
	6Ch	Get/Set	Analog data format •Analog I, O, I/O	USINT	0=Offset binary 1=Sign and Magnitude 2=2's complement 3=Scaled (Scaled cannot be set for analog input)
	6Dh	Get/Set	Monitoring the power supply voltage (For control and input) •SI	BOOL	0=Disable 1=Enable
	6Eh	Get/Set	Monitoring the power supply voltage (For output) •SI	BOOL	0=Disable 1=Enable

\*1: 01h to 0Ah indicates the unit number 0 to 9.

•Channel parameter object (1) (Class: 79h to 7Fh) [DeviceNet™ extended object library 2]

Class	Instance	Attribute	Access	Name	Type	Value
79h	01h to 0Ah *1	64h to 83h *2	Get/Set	Open circuit detection •SI •Digital I(DX□C1) •Digital O, I/O	BOOL	0=Disable 1=Enable
7Ah				ON/OFF count upper limit detection •SI •Digital I, O, I/O	BOOL	0=Disable 1=Enable
7Bh				ON/OFF count upper limit value •SI •Digital I, O, I/O	UINT	1 to 65000 (Times diagnosis is detected=Set value x1000)
7Ch				Analog user set value upper limit detection •Analog I, O, I/O	BOOL	0=Disable 1=Enable
7Dh				Analog user set value upper limit value •Analog I, O, I/O	UINT	
7Eh				Analog user set value lower limit detection •Analog I, O, I/O	BOOL	0=Disable 1=Enable
7Fh				Analog user set value lower limit value •Analog I, O, I/O	UINT	

\*1: 01h to 0Ah indicates the unit number 0 to 9.

\*2: 64h to 83h indicates the channel number 0 to 31.

•Channel parameter object (2) (Class: 83h to 8Ah) [DeviceNet™ extended object library 2]

Class	Instance	Attribute	Access	Name	Type	Value
83h	01h to 0Ah *1	64h to 83h *2	Get/Set	Output setting at the time of communication error •SI •Digital O, I/O •Analog O, I/O	BOOL	0=Disable (Hold) 1=Enable (Clear or Force ON)
84h				Output setting at the time of communication error (Digital) •SI •Digital O, I/O	BOOL	0=OFF (Clear) 1=ON (Force ON)
85h				Output setting at the time of communication error (Analog) •Analog O, I/O	UINT	
86h				Output setting at the time of communication idling •SI •Digital O, I/O •Analog O, I/O	BOOL	0=Disable (Hold) 1=Enable (Clear or Force ON)
87h				Output setting value at the time of communication idling (Digital) •SI •Digital O, I/O	BOOL	0=OFF (Clear) 1=ON (Force ON)
88h				Output setting value at the time of communication idling (Analog) •Analog O, I/O	UINT	
89h				Analog average filter •Analog I, I/O	USINT	0=None 1=2 value average 2=4 value average 3=8 value average
8Ah				Analog range •Analog I, O, I/O	USINT	0=-10...+10 V (Analog input unit only) 1=-5...+5 V (Analog input unit only) 2=-20...+20 mA (Analog input unit only) 3=0...10 V 4=0...5 V 5=1...5 V 6=0...20mA 7=4...20mA

\*1: 01h to 0Ah indicates the unit number 0 to 9.

\*2: 64h to 83h indicates the channel number 0 to 31.

## Accessories

For the selection of accessories, refer to the catalog.

### (1) Valve plate

#### EX600-ZMV1

Enclosed parts: Round head screw (M4x6), 2 pcs.

Round head screw (M3x8), 4 pcs.

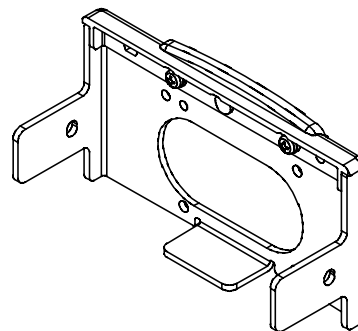

#### EX600-ZMV2 (Specified for SY series)

Enclosed parts: Round head screw (M4x6), 2 pcs.

Round head screw (M3x8), 2 pcs.

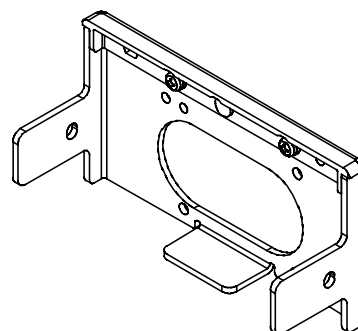

### (2) End plate bracket

#### EX600-ZMA2

Enclosed parts: Round head screw (M4x20), 1 pc.

P tight screw (4x14), 2 pcs.

#### EX600-ZMA3 (Specified for SY series)

Enclosed parts: Round head screw (M4x20) with washer, 1 pcs.

P tight screw (4x14), 2 pcs.

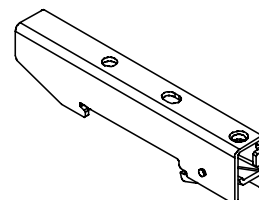

### (3) Intermediate support bracket

#### EX600-ZMB1...for direct mounting

Enclosed parts: Round head screw (M4x5), 2 pcs.

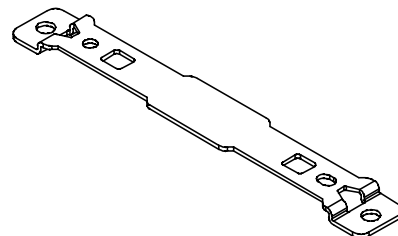

#### EX600-ZMB2...for DIN rail mounting

Enclosed parts: Round head screw (M4x6), 2 pcs.

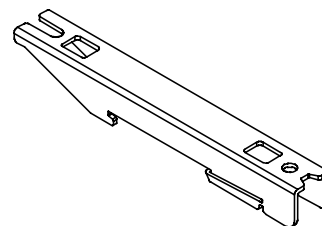

- (4) Seal cap (10 pcs.)  
EX9-AWES...for M8  
EX9-AWTS...for M12

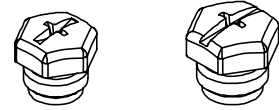

- (5) Marker (1 sheet, 88 pcs.)  
EX600-ZT1

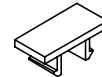

- (6) Y Junction connector  
PCA-1557785 2xM12 (5 pin) – M12 (5 pin)

- (7) Assembled type connector  
PCA-1578078 for power supply, 7/8 inch, Plug, Cable O.D. 12 to 14 mm  
PCA-1578081 for power supply, 7/8 inch, Socket, Cable O.D. 12 to 14 mm  
PCA-1557659 for DeviceNet™ communication, Plug  
PCA-1557662 for DeviceNet™ communication, Socket  
PCA-1557730 M8 (3 pin), Plug  
PCA-1557743 M12 (4 pin), Plug, for AWG26 to AWG22, SPEEDCON compatible  
PCA-1557756 M12 (4 pin), Plug, for AWG22 to AWG18, SPEEDCON compatible

- (8) Power supply cable  
PCA-1558810 Cable with 7/8 inch connector, Socket, Straight 2 m  
PCA-1558823 Cable with 7/8 inch connector, Socket, Straight 6 m  
PCA-1558836 Cable with 7/8 inch connector, Socket, Right angle 2 m  
PCA-1558849 Cable with 7/8 inch connector, Socket, Right angle 6 m  
PCA-1564927 Cable with M12 connector, B code, Socket, Straight 2 m, SPEEDOCON compatible  
PCA-1564930 Cable with M12 connector, B code, Socket, Straight 6 m, SPEEDOCON compatible  
PCA-1564943 Cable with M12 connector, B code, Socket, Right angle 2 m, SPEEDOCON compatible  
PCA-1564969 Cable with M12 connector, B code, Socket, Right angle 6 m, SPEEDOCON compatible

- (9) DeviceNet™ communication cable  
PCA-1557633 Cable with M12 connector, A code, Socket, Straight 5 m, SPEEDOCON compatible  
PCA-1557646 Cable with M12 connector, A code, Plug, Straight 5 m, SPEEDOCON compatible

- (10) Connector extension cable  
PCA-1557769 M12 (4 pin), Straight 3 m  
PCA-1557772 M8 (3 pin), Straight 3 m

Revision history
A: Modify an error in writing.
B: Revision (Pollution degree)

# SMC Corporation

4-14-1, Sotokanda, Chiyoda-ku, Tokyo 101-0021 JAPAN  
Tel: +81 3 5207 8249 Fax: +81 3 5298 5362  
URL <http://www.smcworld.com>

---

Note: Specifications are subject to change without prior notice and any obligation on the part of the manufacturer.  
© 2010-2011 SMC Corporation All Rights Reserved

