



Operation Manual

PRODUCT NAME

Fieldbus system
CC-Link compatible SI unit

MODEL / Series / Product Number

EX600-SMJ#
EX600-ED#

SMC Corporation



Table of Contents

Safety Instructions	2
System Outline	8
Definition and terminology	9
Assembly	11
Basic precautions	11
Mounting and Installation	14
Installation	14
Wiring	16
SI Unit	
Model Indication and How to Order	17
Names and Functions of Product	17
Mounting and Installation	18
Wiring	18
Setting and Adjustment	19
LED Display	25
Specification	27
Specifications	27
Dimensions	28
Endplate	
Model Indication and How to Order	29
Names and Functions of Product	29
Mounting and Installation	30
Wiring	30
Specification	31
Specifications	31
Dimensions	31
Maintenance	33
Troubleshooting	34
Parameter Setting	44
Parameter definition and setting	44
I/O Map	57
Diagnostic	59
Details of diagnostic	60
Accessories	64

Safety Instructions

These safety instructions are intended to prevent hazardous situations and/or equipment damage. These instructions indicate the level of potential hazard with the labels of "Caution", "Warning" or "Danger". They are all important notes for safety and must be followed in addition to International standards (ISO/IEC) *1) and other safety regulations.

- *1) ISO 4414: Pneumatic fluid power -- General rules relating to systems
- ISO 4413: Hydraulic fluid power -- General rules relating to systems
- IEC 60204-1: Safety of machinery -- Electrical equipment of machines (Part 1: General requirements)
- ISO 10218-1992: Manipulating industrial robots -Safety.
- etc.

-  **Caution** : CAUTION indicates a hazard with a low level of risk which, if not avoided, could result in minor or moderate injury.
-  **Warning** : WARNING indicates a hazard with a medium level of risk which, if not avoided, could result in death or serious injury.
-  **Danger** : DANGER indicates a hazard with a high level of risk which, if not avoided, will result in death or serious injury.

Warning

- 1. The compatibility of the product is the responsibility of the person who designs the equipment or decides its specifications.**

Since the product specified here is used under various operating conditions, its compatibility with specific equipment must be decided by the person who designs the equipment or decides its specifications based on necessary analysis and test results. The expected performance and safety assurance of the equipment will be the responsibility of the person who has determined its compatibility with the product. This person should also continuously review all specifications of the product referring to its latest catalog information, with a view to giving due consideration to any possibility of equipment failure when configuring the equipment.
- 2. Only personnel with appropriate training should operate machinery and equipment.**

The product specified here may become unsafe if handled incorrectly. The assembly, operation and maintenance of machines or equipment including our products must be performed by an operator who is appropriately trained and experienced.
- 3. Do not service or attempt to remove product and machinery/equipment until safety is confirmed.**
 1. The inspection and maintenance of machinery/equipment should only be performed after measures to prevent falling or runaway of the driven objects have been confirmed.
 2. When the product is to be removed, confirm that the safety measures as mentioned above are implemented and the power from any appropriate source is cut, and read and understand the specific product precautions of all relevant products carefully.
 3. Before machinery/equipment is restarted, take measures to prevent unexpected operation and malfunction.
- 4. Contact SMC beforehand and take special consideration of safety measures if the product is to be used in any of the following conditions.**
 1. Conditions and environments outside of the given specifications, or use outdoors or in a place exposed to direct sunlight.
 2. Installation on equipment in conjunction with atomic energy, railways, air navigation, space, shipping, vehicles, military, medical treatment, combustion and recreation, or equipment in contact with food and beverages, emergency stop circuits, clutch and brake circuits in press applications, safety equipment or other applications unsuitable for the standard specifications described in the product catalog.
 3. An application which could have negative effects on people, property, or animals requiring special safety analysis.
 4. Use in an interlock circuit, which requires the provision of double interlock for possible failure by using a mechanical protective function, and periodical checks to confirm proper operation.

Caution

The product is provided for use in manufacturing industries.

The product herein described is basically provided for peaceful use in manufacturing industries. If considering using the product in other industries, consult SMC beforehand and exchange specifications or a contract if necessary.
If anything is unclear, contact your nearest sales branch.

Limited warranty and Disclaimer/Compliance Requirements

The product used is subject to the following "Limited warranty and Disclaimer" and "Compliance Requirements".

Read and accept them before using the product.

Limited warranty and Disclaimer

1. The warranty period of the product is 1 year in service or 1.5 years after the product is delivered. *2)
Also, the product may have specified durability, running distance or replacement parts. Please consult your nearest sales branch.
2. For any failure or damage reported within the warranty period which is clearly our responsibility, a replacement product or necessary parts will be provided.
This limited warranty applies only to our product independently, and not to any other damage incurred due to the failure of the product.
3. Prior to using SMC products, please read and understand the warranty terms and disclaimers noted in the specified catalog for the particular products.

*2) Vacuum pads are excluded from this 1 year warranty.

A vacuum pad is a consumable part, so it is warranted for a year after it is delivered.

Also, even within the warranty period, the wear of a product due to the use of the vacuum pad or failure due to the deterioration of rubber material are not covered by the limited warranty.

Compliance Requirements

1. The use of SMC products with production equipment for the manufacture of weapons of mass destruction (WMD) or any other weapon is strictly prohibited.
2. The exports of SMC products or technology from one country to another are governed by the relevant security laws and regulation of the countries involved in the transaction. Prior to the shipment of a SMC product to another country, assure that all local rules governing that export are known and followed.

Operator

- ◆ This operation manual is intended for those who have knowledge of machinery using pneumatic equipment, and have sufficient knowledge of assembly, operation and maintenance of such equipment. Only those persons are allowed to perform assembly, operation and maintenance.
- ◆ Read and understand this operation manual carefully before assembling, operating or providing maintenance to the product.

■ Precautions

Warning

- Do not disassemble, modify (including changing the printed circuit board) or repair.
An injury or failure can result.
- Do not operate or set with wet hands.
This may lead to an electric shock.
- Do not operate the product outside of the specifications.
Do not use for flammable or harmful fluids.
Fire, malfunction, or damage to the product can result.
Verify the specifications before use.
- Do not operate in an atmosphere containing flammable or explosive gases.
Fire or an explosion can result.
This product is not designed to be explosion proof.
- If using the product in an interlocking circuit:
 - Provide a double interlocking system, for example a mechanical system.
 - Check the product regularly for proper operation.Otherwise malfunction can result, causing an accident.
- The following instructions must be followed during maintenance:
 - Turn off the power supply.
 - Stop the air supply, exhaust the residual pressure and verify that the air is released before performing maintenance.Otherwise an injury can result.

Caution

- When handling the unit or assembling/replacing units:
 - Do not touch the sharp metal parts of the connector or plug for connecting units.
 - Take care not to hit your hand when disassembling the unit.
The connecting portions of the unit are firmly joined with seals.
 - When joining units, take care not to get fingers caught between units.
An injury can result.
- After maintenance is complete, perform appropriate functional inspections.
Stop operation if the equipment does not function properly.
Safety cannot be assured in the case of unexpected malfunction.
- Provide grounding to assure the safety and noise resistance of the Fieldbus system.
Individual grounding should be provided close to the product with a short cable.

■ NOTE

- Follow the instructions given below when designing, selecting and handling the product.
- The instructions on design and selection (installation, wiring, environment, adjustment, operation, maintenance, etc.) described below must also be followed.
 - * Product specifications
 - The direct current power supply to combine should be UL 1310 Class2 power supply when conformity to UL is necessary.
 - Use the specified voltage.
Otherwise failure or malfunction can result.
 - The power supply for the unit should be 0V as the standard for both the power supply for outputs and the power supply for inputs and control.

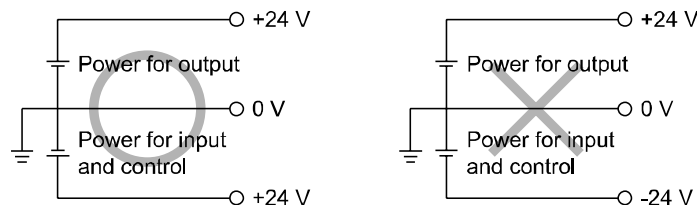

- Reserve a space for maintenance.
Allow sufficient space for maintenance when designing the system.
- Do not remove any nameplates or labels.
This can lead to incorrect maintenance, or misreading of the operation manual, which could cause damage or malfunction to the product.
It may also result in non-conformity to safety standards.
- Beware of inrush current when the power supply is turned on.
Some connected loads can apply an initial charge current which will activate the over current protection function, causing the unit to malfunction.

●Product handling

*Installation

- Do not drop, hit or apply excessive shock to the SI unit.
Otherwise damage to the product can result, causing malfunction.
- Tighten to the specified tightening torque.
If the tightening torque is exceeded the mounting screws may be broken.
IP67 protection cannot be guaranteed if the screws are not tightened to the specified torque.
- If a large manifold valve is mounted, lift the unit so that stress is not applied to the connecting part while transporting.
The stress may cause breakage of the connecting part. The unit may become very heavy depending on the combination. Transportation/installation shall be performed by multiple operators.
- Never mount a product in a location that will be used as a foothold.
The product may be damaged if excessive force is applied by stepping or climbing onto it.

*Wiring

- Avoid repeatedly bending or stretching the cables, or placing heavy load on them.
Repetitive bending stress or tensile stress can cause breakage of the cable.
- Wire correctly.
Incorrect wiring can break the product.
- Do not perform wiring while the power is on.
Otherwise damage to the SI unit and/or input or output device can result, causing malfunction.
- Do not route wires and cables together with power or high voltage cables.
Otherwise the SI unit and/or input or output device can malfunction due to interference of noise and surge voltage from power and high voltage cables to the signal line.
Route the wires (piping) of the SI unit and/or input or output device separately from power or high voltage cables.
- Confirm proper insulation of wiring.
Poor insulation (interference from another circuit, poor insulation between terminals, etc.) can lead to excess voltage or current being applied to the product, causing damage.
- Take appropriate measures against noise, such as using a noise filter, when the Fieldbus system is incorporated into equipment.
Otherwise noise can cause malfunction.

*Environment

- Select the proper type of protection according to the environment of operation.
IP67 protection is achieved when the following conditions are met.
 - (1)The units are connected properly with fieldbus cable with M12 connector and power cable with M12 (M8) connector.
 - (2)Suitable mounting of each unit and manifold valve.
 - (3)Be sure to fit a waterproof cap on any unused connectors.
If using in an environment that is exposed to water splashes, please take measures such as using a cover.
Do not use in an environment where moisture or water vapor are present. Otherwise failure and malfunction can result.
- Do not use in a place where the product could be splashed by oil or chemicals.
If the product is to be used in an environment containing oils or chemicals such as coolant or cleaning solvent, even for a short time, it may be adversely affected (damage, malfunction etc.).
- Do not use the product in an environment where corrosive gases or fluids could be splashed.
Otherwise damage to the product and malfunction can result.
- Do not use in an area where surges are generated.
If there is equipment generating large surge near the unit (magnetic type lifter, high frequency inductive furnace, welding machine, motor, etc.), this can cause deterioration of the internal circuitry element of the unit or result in damage. Take measures against the surge sources, and prevent the lines from coming into close contact.

- When a surge-generating load such as a relay, valve or lamp is driven directly, use a product with a built-in surge absorbing element.
Direct drive of a load generating surge voltage can damage the unit.
- The product is CE marked, but not immune to lightning strikes. Take measures against lightning strikes in the system.
- Prevent foreign matter such as dust or wire debris from getting inside the product.
- Mount the product in a place that is not exposed to vibration or impact.
Otherwise failure or malfunction can result.
- Do not use the product in an environment that is exposed to temperature cycle.
Heat cycles other than ordinary changes in temperature can adversely affect the inside of the product.
- Do not expose the product to direct sunlight.
If using in a location directly exposed to sunlight, shade the product from the sunlight.
Otherwise failure or malfunction can result.
- Keep within the specified ambient temperature range.
Otherwise malfunction can result.
- Do not operate close to a heat source, or in a location exposed to radiant heat.
Otherwise malfunction can result.

***Adjustment and Operation**

- Set the switches by using a sharp-pointed screwdriver etc. When setting the switch, do not touch other unrelated parts.
This can cause parts damage or malfunction due to a short circuit.
- Perform settings suitable for the operating conditions.
Incorrect setting can cause operation failure.
For details of each setting, refer to page 19 to 24 of this manual.
- Please refer to the PLC manufacturer's manual etc. for details of programming and addresses.
For the PLC protocol and programming refer to the relevant manufacturer's documentation.

***Maintenance**

- Turn off the power supply, stop the supplied air, exhaust the residual pressure and verify the release of air before performing maintenance.
There is a risk of unexpected malfunction.
- Perform regular maintenance and inspections.
There is a risk of unexpected malfunction.
- After maintenance is complete, perform appropriate functional inspections.
Stop operation if the equipment does not function properly.
Otherwise safety is not assured due to an unexpected malfunction or incorrect operation.
- Do not use solvents such as benzene, thinner etc. to clean each unit.
They could damage the surface of the body and erase the markings on the body.
Use a soft cloth to remove stains.
For heavy stains, use a cloth soaked with diluted neutral detergent and fully squeezed, then wipe up the stains again with a dry cloth.

System Outline

•System configuration

The EX600 range of units can be connected to various types of Fieldbus to realize the reduction of input or output device wiring and the distributed control system. The unit communicates with the Fieldbus through the SI unit. One SI unit can be connected with manifold valves with up to 32 outputs and the input • output • I/O units with maximum 10 units.

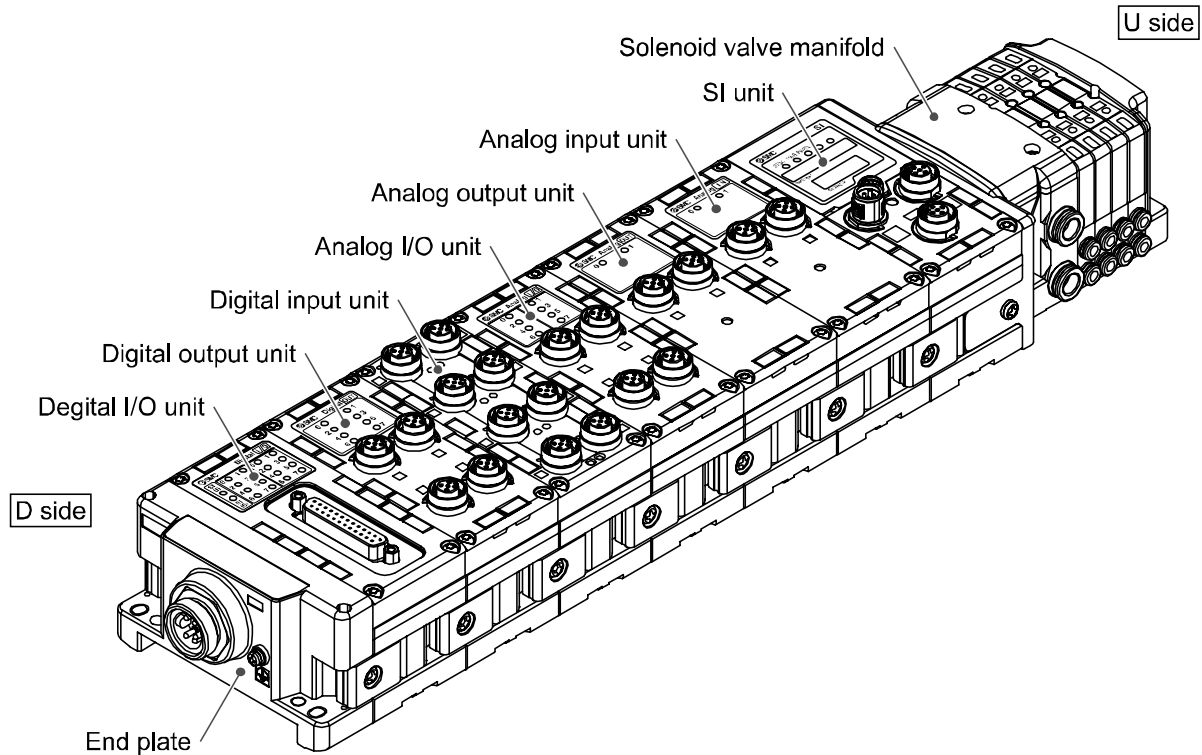

SI unit: Performs Fieldbus communication and solenoid valve manifold ON/OFF output.

Digital input unit: For connecting sensors with switch output capability. PNP and NPN types are available.

Digital output unit: For connecting output device such as solenoid valves, lamps, buzzers, etc. PNP and NPN types are available.

Digital I/O unit: This unit has both digital input and output functions. PNP and NPN types are available.

Analog input unit: For connecting sensors with analog output capability.

Analog output unit: This can be connected to the equipment which can read analog input.

Analog I/O unit: This unit has both analog input and output functions.

End plate: Connected at EX600 Manifold's D side, incorporating the power supply connection.

Solenoid valve manifold: An assembly of solenoid valves. One connector is used as the electric connection to all connected valves.

■ Definition and terminology

	Terminology	Definition
A	AD value	The signal from the analog input device is converted to digital, and displayed in decimal and hexadecimal. These hexadecimal and decimal values are also outputted to the analog output device.
C	Communication speed	The speed at which the fieldbus sends and receives data. It depends on higher-level equipment (PLC, etc.) and is measured in bps (Bits per second).
	Current consumption	The current necessary to operate each unit.
D	DIN rail	A metal rail conforming with DIN (German) standard.
	D Side	The side connected to the end plate when the product is connected to a manifold.
E	Enclosure (IP□□)	Abbreviation of international (ingress) protection. A standard related to the protection from external objects (hands, steel ball, steel wire, dust, water, etc.) applied to the product.
F	FE	Abbreviation of functional earth.
	Fieldbus	The protocol that uses digital communication to exchange signals between field equipment (instruments and actuators) running on site and a PLC.
H	Handheld Terminal (H.T.)	Connected to the dedicated connector of the SI unit to adjust the internal parameters, monitor the status of all input and output signals, and turn on input and output forcibly.
M	Manifold	A form consisting of multiple components. A form made by combining multiple components
N	Station number	0 is assigned to the master station of CC-Link. 1 to 64 are assigned to slave stations. It is necessary to assign station numbers to slave stations taking into consideration the number of occupied stations, so that the station numbers are not duplicated.
	NPN input	Takes the sensor output that uses the NPN transistor to the signal output line.
	NPN output	The output type that uses an NPN transistor to operate output device. It is also known as a positive common type since a positive potential is applied to the power supply line.
	Number of inputs	The number of points that can receive information from input device (sensor, switch, etc.).
	Number of outputs	The number of points that can operate output device (solenoid valve, light, motor, etc.).
	Number of stations	The total number of occupied slave stations connected to CC-Link.
O	Occupied station number	Station number that one slave station uses on the network. It can be set from 1 to 4 stations depending on the number of data. Remote I/O occupies only one station.
	Open circuit detection	A diagnosis function to detect if the input or output device wiring is disconnected.
P	PLC	Abbreviation of programmable logic controller. A digital computer used for automation of electromechanical processes.
	PNP input	Takes the sensor output that uses the PNP transistor to the signal output part.
	PNP output	The output type that uses a PNP transistor to operate output device. It is also known as a negative common type since a negative potential is applied to the power supply line.
R	Remote device station	Collective description of slave station. Bit data and word data can be used in this station.
	Remote I/O	Collective description of slave station. Only bit data can be used in this station. (Only one station is occupied.)

	Terminology	Definition
S	Short circuit detection	A diagnosis function to detect an over current due to the short circuit of the output and/or power supply positive line with respect to the GND line.
	Short circuit protection	A function to protect the internal circuit from being broken by an over current due to the short circuit of the output and/or power supply positive line with respect to the GND line.
	SI unit	Abbreviation of serial interface unit. A unit connected to a PLC to communicate input and output data.
T	Terminal resistor	A resistor mounted at either end of the fieldbus network.
U	U Side	The side connected to the solenoid valve when the product is connected to a manifold.
V	Ver.2.00	Ver. 2.00 means "CC-Link Ver. 2.00". It allows sending/ receiving large amounts of data such as the sending/ receiving of multiple channel analog/ digital converted data.

Assembly

Basic precautions

The units that can be connected vary depending on the Handheld Terminal product number.

Units that can be assembled			Product number of the Handheld Terminal	
			EX600-HT1	EX600-HT1A
Product number	SI unit	EX600-SMJ□	○	○
	Digital input unit	EX600-DX□B	○	○
		EX600-DX□C□	○	○
		EX600-DX□D	○	○
		EX600-DX□E	×	○
		EX600-DX□F	×	○
	Disital output unit	EX600-DY□B	○	○
		EX600-DY□E	×	○
		EX600-DY□F	×	○
	Digital I/O unit	EX600-DM□E	×	○
		EX600-DM□F	×	○
	Analog input unit	EX600-AXA	○	○
Analog output unit	EX600-AYA	×	○	
Analog I/O unit	EX600-AMB	×	○	

*1: EX600-HT1 cannot recognize EX600-D□□E, EX600-D□□F, Ex600-AYA and EX600-AMB.

Find the product number of the Handheld Terminal referring to the label shown in the figure below.

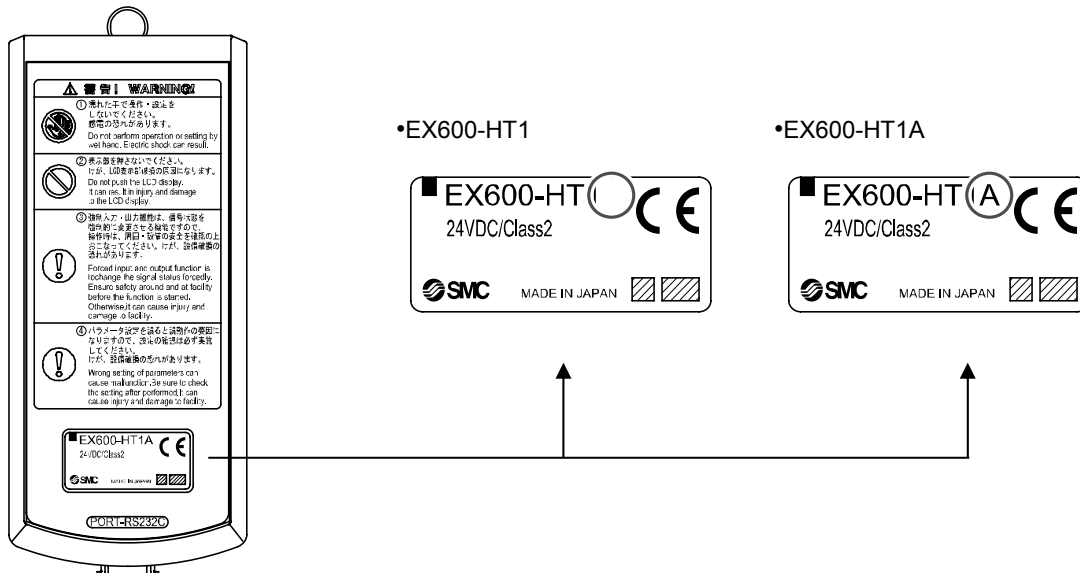

•Composing the unit as a manifold

*: If the unit was purchased as a manifold, the work described in this section is not necessary.

(1)Connect the unit to the end plate.

The Digital unit, Analog unit can be connected in any order.

Tighten the bracket of the joint using tightening torque 1.5 to 1.6 Nm.

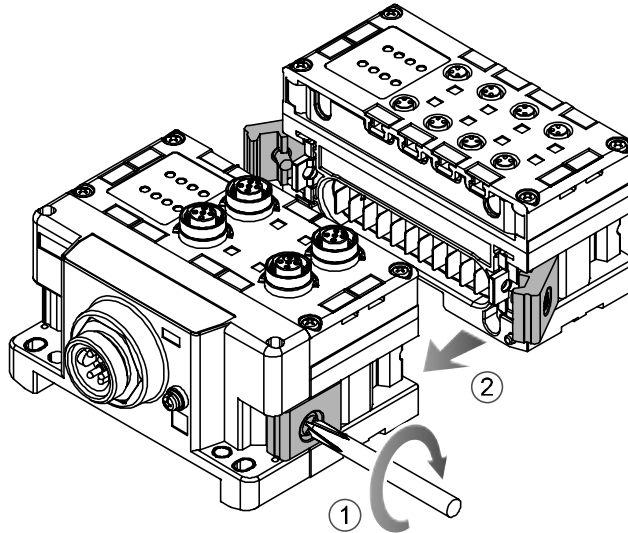

(2)Add more units.

Up to 10 units (including the SI unit) can be connected to one manifold.

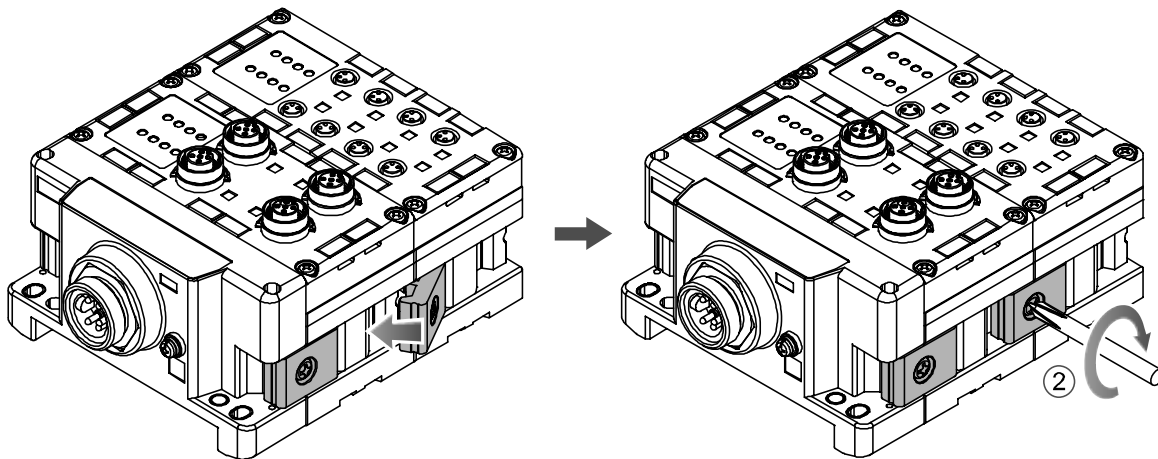

(3)Connecting the SI unit.

After connecting the necessary units, connect the SI unit.

Connecting method is the same as above (1), (2).

(4) Mounting the valve plate.

Mount the valve plate (EX600-ZMV□) to the valve manifold using the valve set screws. (M3x8)
Apply 0.6 to 0.7 Nm tightening torque to the screws.

Screw mounting place	
SV	: 2 places
S0700	: 2 places
VQC1000	: 2 places
VQC2000	: 3 places
VQC4000	: 4 places
SY	: 2 places

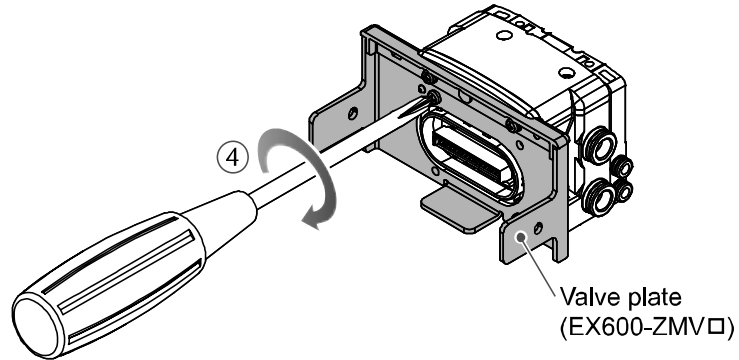

(5) Connect the SI unit and the valve manifold.

Insert the valve plate to the valve plate set groove on the side of SI unit.
Then, tighten it with the valve plate set screws (M4x6) to fix the plate.
Tightening torque for set screws 0.7 to 0.8 Nm.

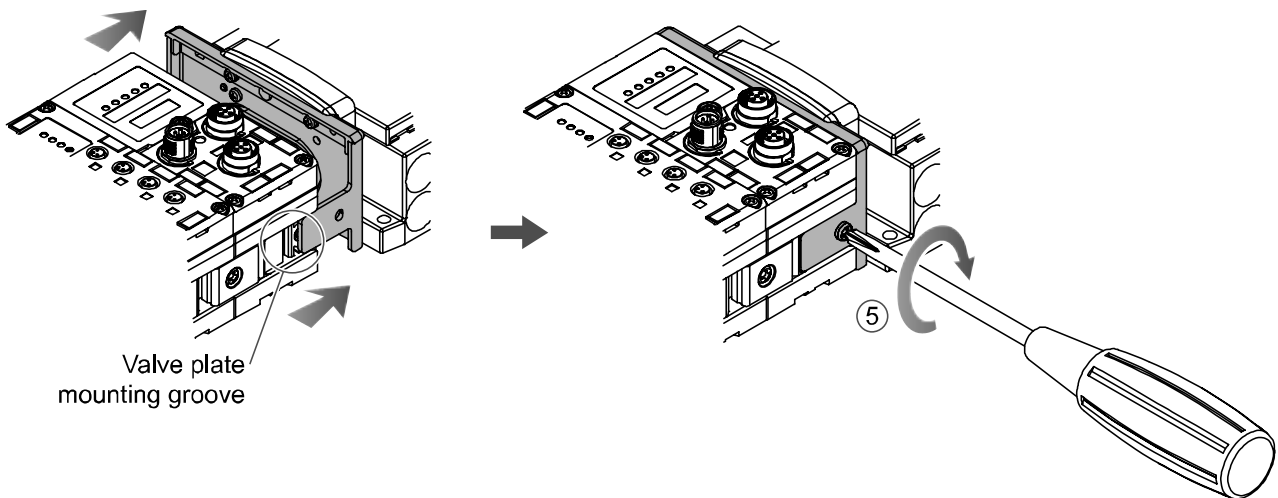

● Precautions for handling

- Please do not connect the unit while the power supply is active. It will cause equipment damage.
- Take care not to drop the nuts of Joint bracket.

Mounting and Installation

■ Installation

• Direct mounting

(1) When joining six or more units, fix the middle part of the complete EX600 unit with an intermediate reinforcing brace (EX600-ZMB1) before mounting using 2-M4x5 screws.

Tightening torque: 0.7 to 0.8 Nm.

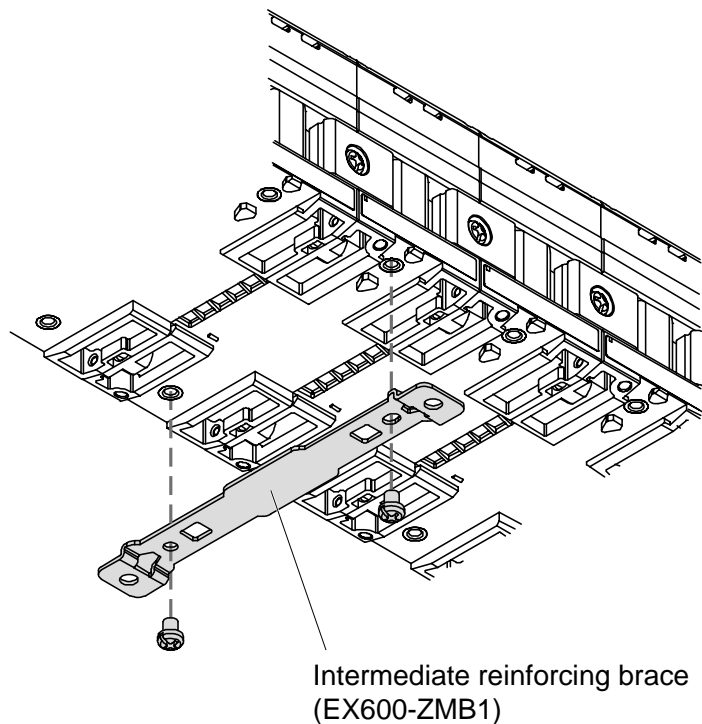

(2) Fix and tighten the end plates at one end of the unit. (M4)

Tightening torque: 0.7 to 0.8 Nm.

Fix the end plate at the valve side while referring to the operation manual of the corresponding valve manifold.

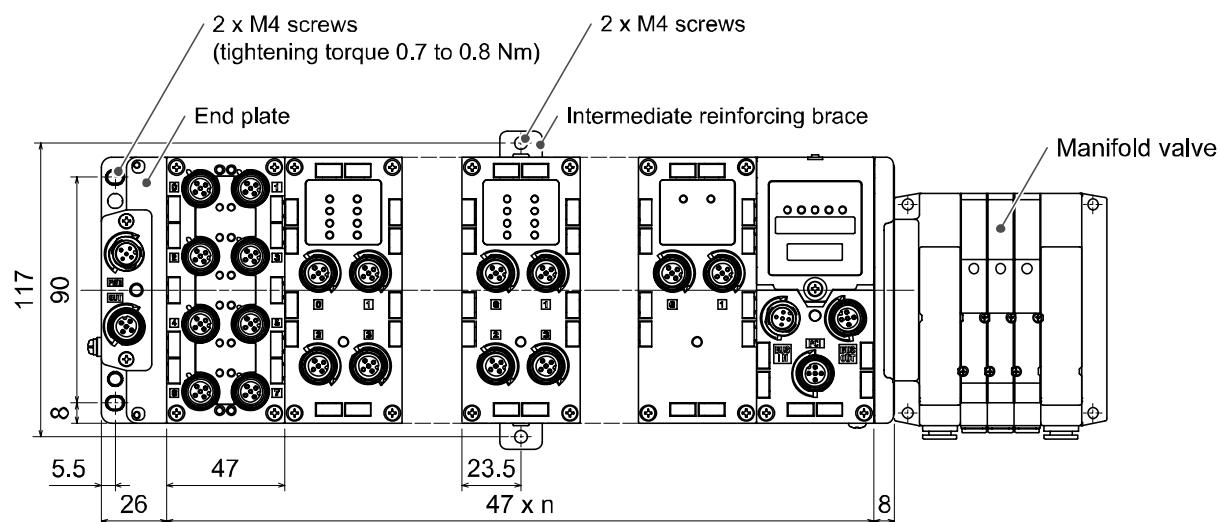

n (Number of connected units) 10

•DIN rail mounting

(Available for series other than SY series. Refer to the catalog for SY series.)

(1)When joining six or more units, fix the middle part of the complete EX600 unit with an intermediate reinforcing brace (EX600-ZMB2) before mounting, using 2-M4x6 screws.

Tightening torque: 0.7 to 0.8 Nm.

(2)Mount the end plate bracket (EX600-ZMA2) to the end plate at the opposite end to the valves, using 2-M4x14 screws.

Tightening torque: 0.7 to 0.8 Nm.

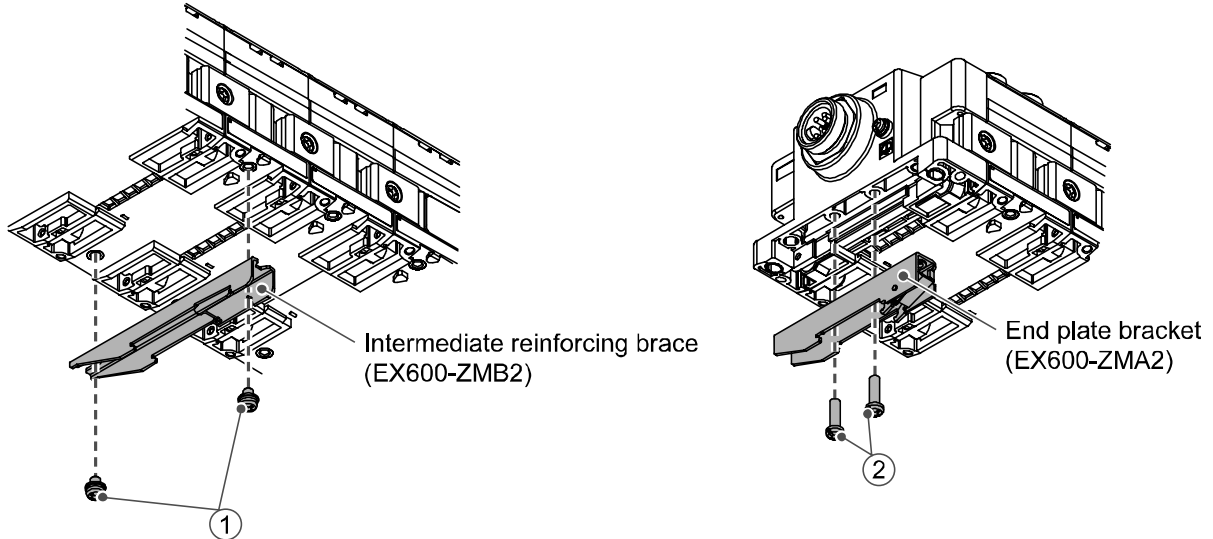

(3)Hook the DIN rail mounting groove to the DIN rail.

(4)Press the manifold using its side hooked to the DIN rail as a fulcrum until the manifold is locked.

(5)Fix the manifold by tightening the DIN rail fixing screws of the EX600-ZMA2. (M4x20)

Tightening torque: 0.7 to 0.8 Nm.

The tightening torque at the valve side depends on the valve type.

Refer to the operation manual of the corresponding valve manifold.

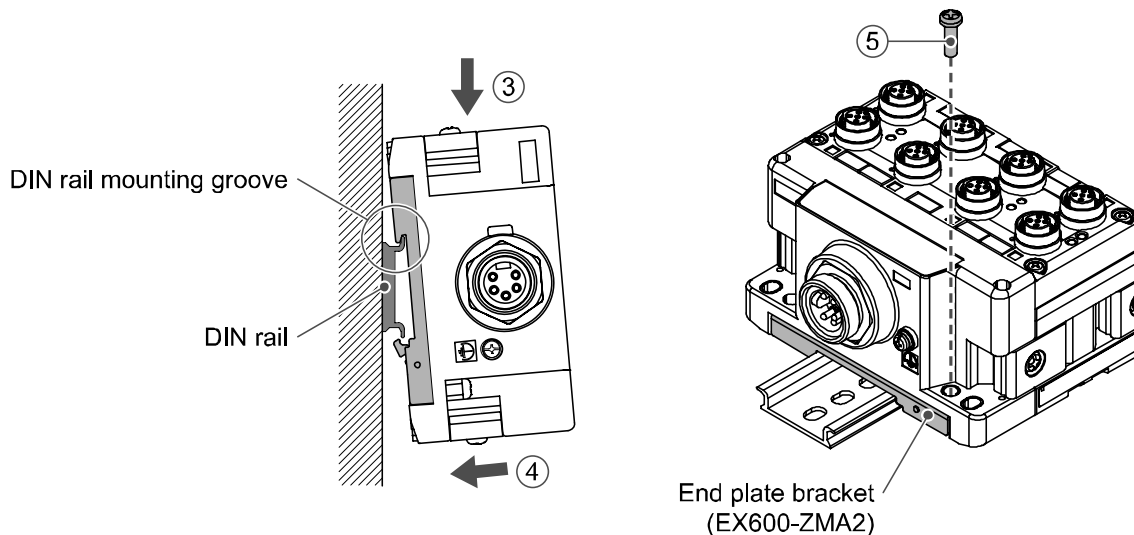

■Wiring

•Connect the M12 or M8 connector cable. M12 connector is applicable for SPEEDCON connector. SPEEDCON connector wiring method is explained below.

(1)Align the mark B on the metal bracket of the cable side connector (plug/socket) with the mark A.

(2)Align the mark C on the unit and insert the connector into the unit vertically.

If they are not aligned, the connector cannot be joined properly.

(3)When the mark B of the connector has been turned 180 degrees (1/2 turn), wiring is completed. Confirm that the connection is not loose. If turned too far, it will become hard to remove the connector.

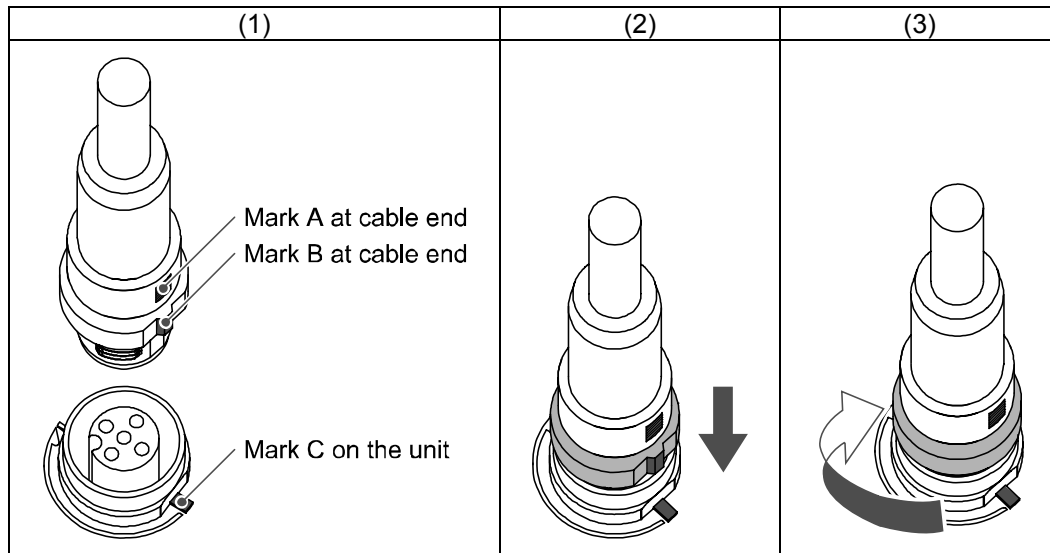

•Mounting the marker

Signal name of the input or output devices and unit address can be written to the marker, and it can be installed to each unit.

Mount the marker (EX600-ZT1) into the marker groove as required.

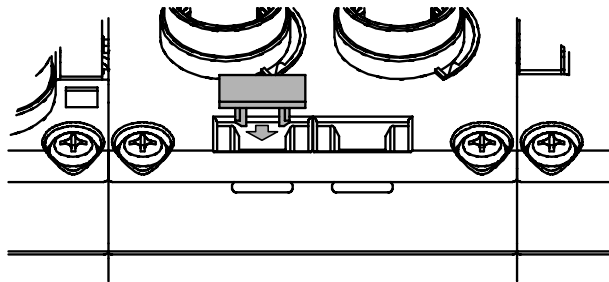

SI unit

Model Indication and how to Order

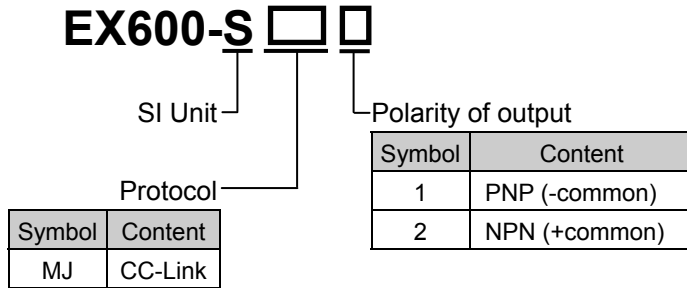

Names and Functions of Product

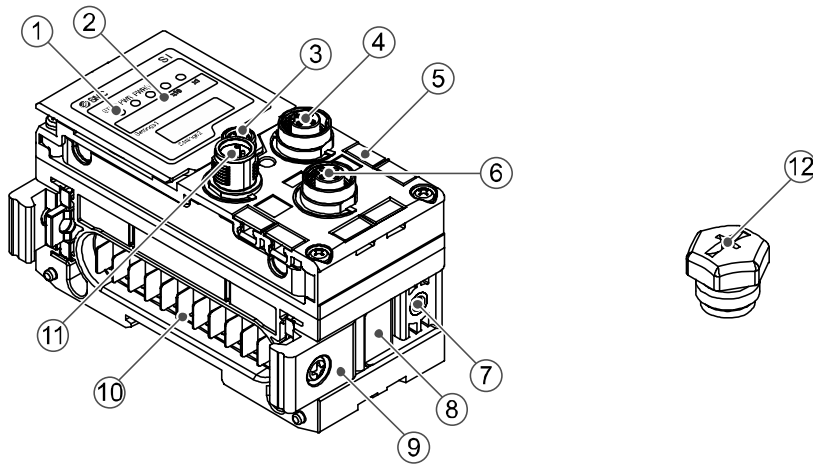

No.	Description	Function
1	Status display LED	Displays the status of the unit.
2	Display cover	Open for the setting of switch.
3	Display cover tightening screw	Loosen to open the display cover.
4	Connector (BUS OUT)	Connects the cable for fieldbus outputs.
5	Marker groove	Groove to mount a marker.
6	Connector (PCI)	Connects the cable of the Handheld Terminal.
7	Valve plate mounting screw hole	Fixes the valve plate.
8	Valve plate mounting groove	Groove to insert the valve plate into.
9	Joint bracket	Bracket for joining to adjacent units.
10	Unit connector (Plug)	Transmits signals and power supplies to adjacent units.
11	Connector (BUS IN)	Connects the cable for fieldbus inputs.
12	Seal cap (2 pcs.)	Mounted on to unused connectors. (BUS OUT and PCI)

Mounting and Installation

■Wiring

○Connector pin assignment and circuit diagram

•Connector pin assignment

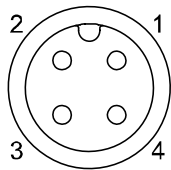
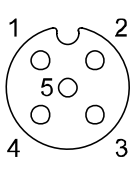
Configuration		Pin number	Signal name
BUS IN	BUS OUT		
		1	SLD
		2	DB
		3	DG
		4	DA
		5	NC

•Circuit diagram

The product has T branching internally in the unit as shown in the circuit diagram below. It can be extended by connecting the CC-Link slave with BUS OUT.

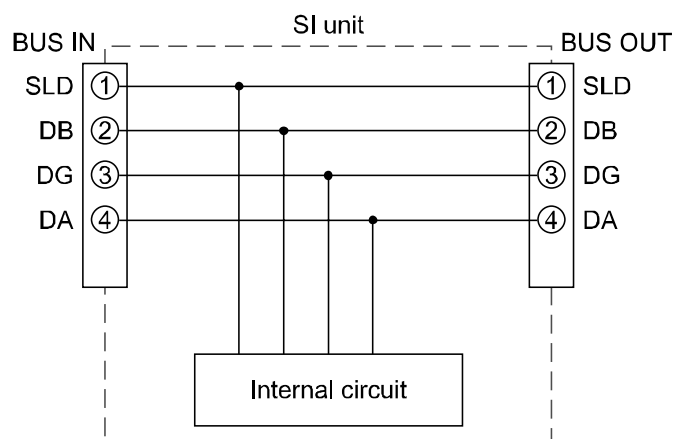

•Precautions for handling

- Be sure to connect terminal resistors to both ends of the CC-Link main line.
- Be sure to fit a seal cap on any unused connectors. Proper use of the seal cap enables the enclosure to achieve IP67 specification.

•Terminal resistors

The terminal resistors to be connected to the CC-Link system depend on the cables used.

Type of cable	Resistance	Terminal resistor model No. (Manufacturer)
Communication cable for CC-Link PCA-1567720 (Socket) PCA-1567717 (Plug)	110 Ω 1/2 W	<ul style="list-style-type: none"> •VA-4DCC-110 (Correns) •CC100 (Woodhead Japan)
CC-Link dedicated high-performance cable	130 Ω 1/2 W	<ul style="list-style-type: none"> •VA-4DCC-130 (Correns)

Setting and Adjustment

•Switch setting

- (1) Loosen the display cover screw.
- (2) Open the display cover using a flat head screwdriver, etc.

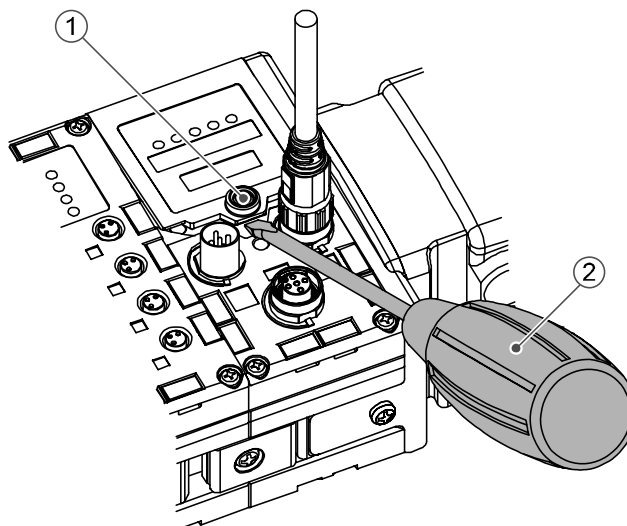

- (3) Set the switch using a small watchmaker's screwdriver with a thin blade, referring to the setting of switch on the following pages.
- (4) After setting the switch, tighten the display cover tightening screw in the reverse order of the above procedure. (Tightening torque: 0.3 to 0.4 Nm)

•Precautions for handling

- Turn off the power supply whilst setting the switch.
- If there is foreign matter or water droplets around the display cover, clean it off before opening the cover.
- When setting the switch, do not touch other unrelated parts. This can cause parts damage or malfunction due to a short circuit.
- All default settings are OFF or 0. Perform the setting of the switch before using this product.
- When introducing power supply, switch setting will become effective.

- Operation mode switch: Sets the version of CC-Link and the number of occupied stations.

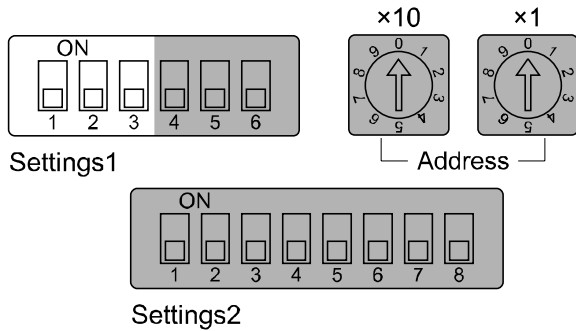

Operating mode	Settings1			Content				
	1	2	3	CC-Link version	Number of occupied stations	Bit area input/output*2	Word area input/output size (RWr/RWr)	Extended cyclic (Ver2.00)
1 *1	OFF	OFF	OFF	1.10	1	32/32	4 word/4 word	-
2	ON	OFF	OFF	1.10	2	64/64	8 word/8 word	-
3	OFF	ON	OFF	1.10	3	96/96	12 word/12 word	-
4	ON	ON	OFF	1.10	4	128/128	16 word/16 word	-
5	OFF	OFF	ON	2.00	1	64/64	16 word/16 word	4 times
6	ON	OFF	ON	2.00	1	128/128	32 word/32 word	8 times
7	OFF	ON	ON	2.00	2	384/384	64 word/64 word	8 times
8	ON	ON	ON	2.00	3	640/640	96 word/96 word	8 times

*1: The default operation mode at the time of shipment is mode 1.

*2: The last register of bit area (16 bits) cannot be used as they are allocated for the system area.

- Communication speed switch: Sets the communication speed of CC-Link.

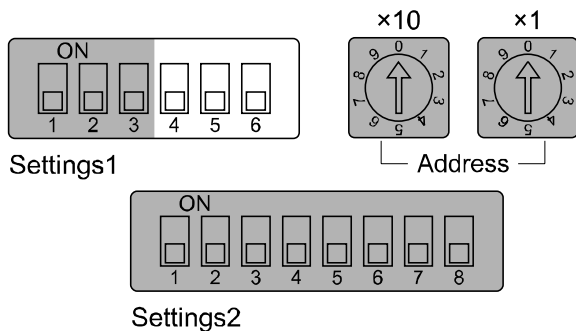

Settings1			Content
4	5	6	
OFF	OFF	OFF	156 kbps (Default setting)
ON	OFF	OFF	625 kbps
OFF	ON	OFF	2.5 Mbps
ON	ON	OFF	5 Mbps
OFF	OFF	ON	10 Mbps
ON	OFF	ON	Error, [LERR] LED lights up.
OFF	ON	ON	
ON	ON	ON	

•Station setting switch: Set the station number of SI unit

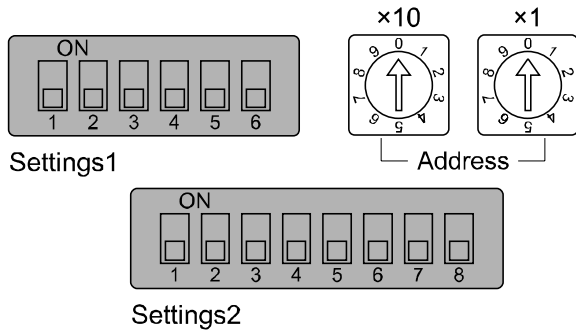

Station number setting

Address		Station number
x10	x1	
0	0	Error (Default setting)
0	1	1
0	2	2
:	:	:
6	3	63
6	4	64
6	5	Error
:	:	
9	9	

*: If a station number is set to 00 or over 65, the "LERR" LED will light up.

The settable range depends on the number of occupied stations.

Number of occupied stations	Settable station number range
1	1 to 64
2	1 to 63
3	1 to 62
4	1 to 61

*: The number of occupied stations is set by the operation mode switch. (Refer to the previous page.)

- V_SEL switch: Select the number of occupied valve outputs.
Select the number of outputs (size) that SI unit occupies.

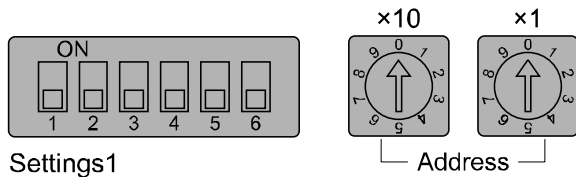

Settings1

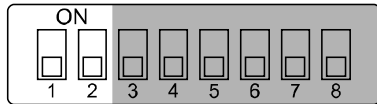

Settings2

Settings2		Content	SI unit output data size
1	2		
OFF	OFF	Number of occupied valve 32 outputs	4 byte (Default setting)
OFF	ON	Number of occupied valve 24 outputs	3 byte
ON	OFF	Number of occupied valve 16 outputs	2 byte
ON	ON	Number of occupied valve 8 outputs	1 byte

*: Set the number of occupied outputs more than the number of valves used.

- Baud Rate switch: Set the communication speed of the EX600 internal bus.

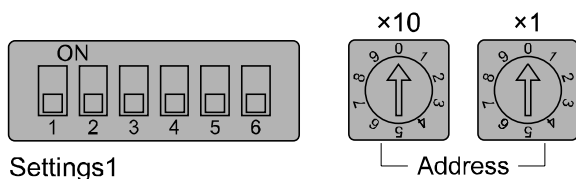

Settings1

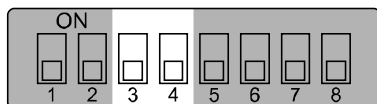

Settings2

Settings2		Content
3	4	
OFF	OFF	1 Mbps (Default setting)
OFF	ON	500 kbps
ON	OFF	250 kbps
ON	ON	125 kbps

*: This function is for extension in the future. Use the product with 1 Mbps (Default setting).

- Switch for diagnosis: Allocates the diagnostic data to the input word area.

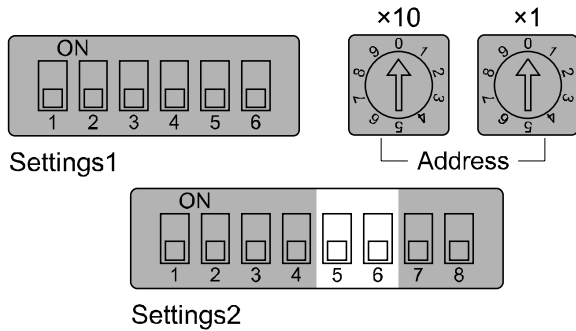

Settings2		Mode	Content	Diagnosis size set for the input
5	6			
OFF	OFF	0	Input data only (Default setting)	0 word
OFF	ON	1	Input data + System diagnosis	2 word
ON	OFF	2	Input data + System diagnosis + Unit diagnosis (Up to 10 units)	3 word
ON	ON	3 *	Input data + System diagnosis + Unit diagnosis (Up to 64 units)	6 word

*: Mode 3 is a function for extension in the future. Do not use it now.

- HOLD/CLEAR switch: Sets the output status when the Fieldbus has a communication error.

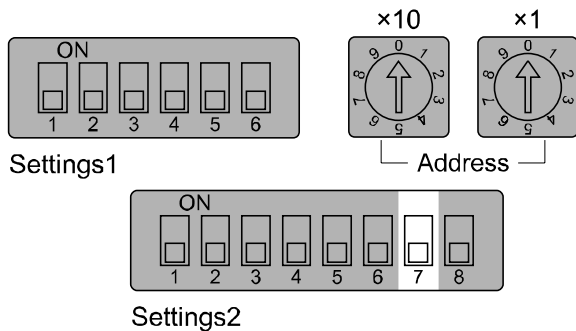

Settings2	Content
7	
OFF	Output is OFF. (Default setting)
ON	Holds the output.

*: Refer to "Parameter setting" (page 44), for the further details.

- Configuration memory switch: When the manifold configuration memory switch is set ON and the power supply is switched ON, the system will compare the stored configuration with the manifold configuration. If the configuration is different, diagnostic error will be generated.

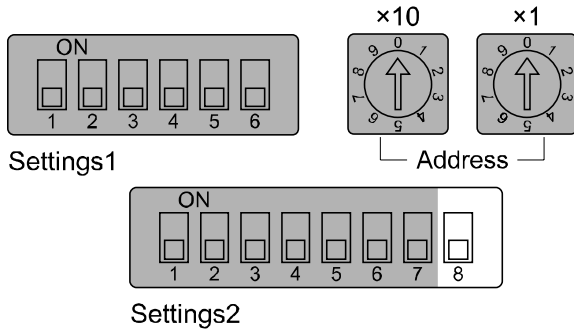

Settings2	Content
8	
OFF	Normal operation mode (Default setting)
ON	Configuration memory mode

Timing to memorize the configuration → When power supply for control and input is turned on, with the switch above turned OFF.

Timing to compare the configuration → When power supply for control and input is turned on, with the switch above turned ON.

- Precautions for handling

Handle the switch with care. Excessive force can break the switch.

LED Display

The status display LED displays the power supply and communication status.
Various kinds of status can be checked as follows:

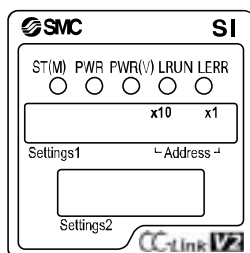





Display	Content
ST(M)	Displays the diagnosis status of the unit.
PWR	Displays the status of the power supply voltage for control and input.
PWR(V)	Displays the status of the power supply voltage for outputs.
LRUN	Displays the data link status.
LERR	Displays the error status.

•SI unit common status

LED display	Content
ST(M) PWR PWR(V) ○ ○ ○ OFF	The power supply for control and input is OFF.
ST(M) PWR PWR(V) ● ● ● Green LEDs are ON	The unit is in normal operation.
ST(M) PWR PWR(V) ● ○ ○ Red ST(M) LED is ON	A component failure inside the SI unit.
ST(M) PWR PWR(V) ○ ● ○ Red PWR LED is ON	The power supply voltage for control and input is abnormal.
ST(M) PWR PWR(V) ○ ○ ● Red PWR(V) LED is ON	The power supply voltage for outputs is abnormal.
ST(M) PWR PWR(V) ● (flashing) ○ ○	A unit other than the SI unit has been diagnosed and detected.
ST(M) PWR PWR(V) ● (flashing) ○ ○ Red ST(M) LED is flashing	Either of the following conditions: •The valve ON/OFF counter has exceeded the set value. •The valve is short circuited or disconnected.
ST(M) PWR PWR(V) ● (flashing alternately) ○ ○ Red/green ST(M) LED is flashing alternately	Either of the following conditions: •Connection error between units has occurred. •Configuration memory error has occurred.

*: Refer to "Troubleshooting" (page 34), for the further details of countermeasures.

•CC-Link status

LED display	Content
LRUN LERR  OFF	Communication is not established. Or, the power supply for control and input is turned off.
LRUN LERR  Green LRUN LED is ON	Communication is normal.
LRUN LERR  Red LERR LED is ON	Communication error has occurred.
LRUN LERR  Red LERR LED is flashing	The station setting or communication speed setting switch has been changed during communication.

*: Refer to "Troubleshooting" (page 34), for the further details of countermeasures.

Specification

■ Specifications

Model		EX600-SMJ1	EX600-SMJ2
Communication	Fieldbus	CC-Link (Ver.1.10, Ver.2.00)	
	Station type	Remote device station	
	Communication speed	156/625 kbps 2.5/5/10 Mbps	
	Occupied area (Number of inputs/outputs)	Max. (512 points/512 points) 1 station/2 stations/3 stations/4 stations occupied	
Power supply (Control and input)		24 VDC Class2, 2 A	
Internal current consumption (The power supply for control and input)		75 mA or less	
Valve output	Polarity of output	PNP (-common)	NPN (+common)
	Output channel	32 outputs (8/16/24/32 outputs selectable)	
	Connected load	Solenoid valve with lamp and circuit of protection of surge voltage of 24 VDC 1.5 W (SMC)	
	Power supply (Output)	24 VDC Class2, 2 A	
	Output for com. error	HOLD/CLEAR/Force ON	
	Protective function	Short circuit protection	
Environment	Enclosure	IP67 (With manifold assembled) *1	
	Operating temperature range	-10 to 50 °C (Max. surrounding air temperature rating: 50 °C) *2	
	Storage temperature range	-20 to 60 °C	
	Operating humidity range	35 to 85%RH (No condensation)	
	Withstand voltage	500 VAC for 1 minute between external terminals and FE	
	Insulation resistance	500 VDC, 10 MΩ or more between external terminals and FE	
	Pollution degree	For use in Pollution Degree 3 Environment (UL508)	
Standard		CE marking, UL (CSA), RoHS	
Weight		300 g	

*1: All unused connectors must have a waterproof cap fitted.

*2: The UL compliant temperature is 0 to 50 °C.

■Dimensions

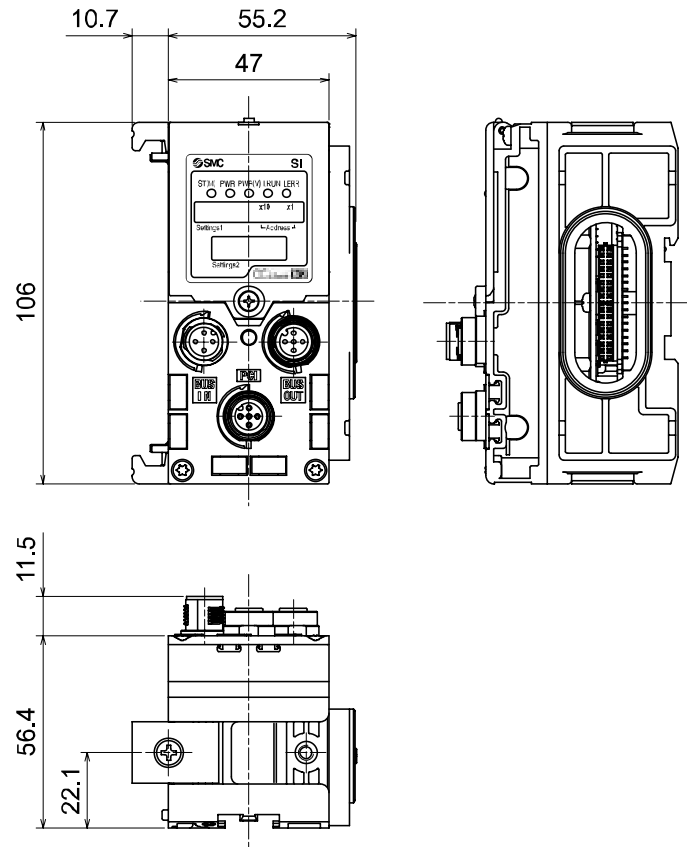

End plate

Model Indication and How to Order

EX600-ED□-□

End plate at D side

Mounting method

Connector

Symbol	Content
2	M12 (5 pin)
3	7/8 inch (5 pin)

Symbol	Content
Nil	No DIN rail bracket
2	With DIN rail bracket
3	With DIN rail bracket (Specified for SY series)

Names and Functions of Product

•EX600-ED2-□

•EX600-ED3-□

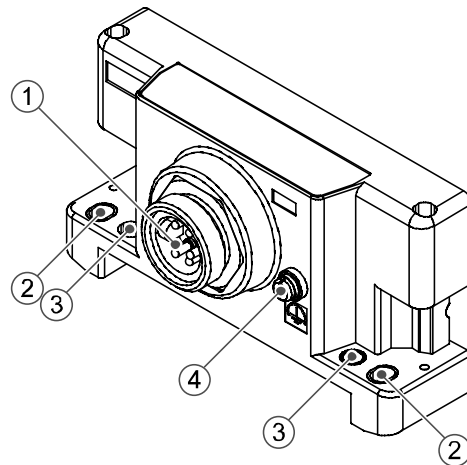
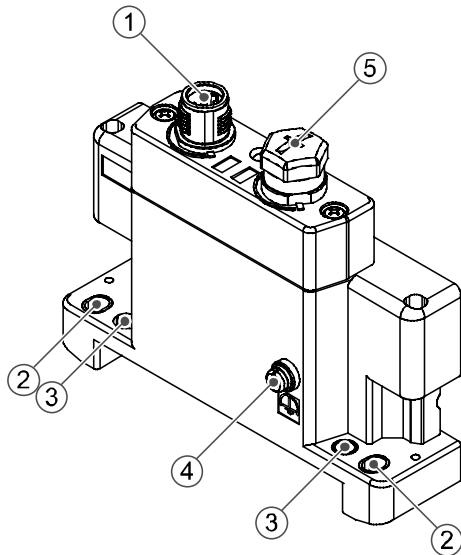

No.	Description	Function
1	Power connector	Supplies power for each unit and input/output device.
2	Fixing hole for direct mounting	Holes used for direct mounting.
3	DIN rail fixing hole	Holes used to fix DIN rail.
4	FE terminal	Terminal used to grounding.
5	Connector (Not used)	This connector is not used. Do not take off the seal cap.

Mounting and Installation

■Wiring

○Connector pin assignment

(1)EX600-ED2-□

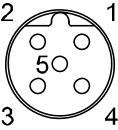
Configuration	Pin No.	Signal name
	1	24 V (Output)
	2	0 V (Output)
	3	24 V (Control and input)
	4	0 V (Control and input)
	5	FE

(2)EX600-ED3-□

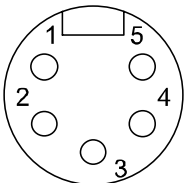
Configuration	Pin No.	Signal name
	1	0 V (Output)
	2	0 V (Control and input)
	3	FE
	4	24 V (Control and input)
	5	24 V (Output)

○Regarding the 2 types of power supply

This product has 2 power supplies, and it is divided as follows.

- Power supply for control and input: Supplying power for control of each unit's power supply for control and also for device connected to input port of digital and analog unit.
- Power supply for output: Supplying power for equipment connected to output port of digital and analog unit, and also power supply for solenoid valve manifold.

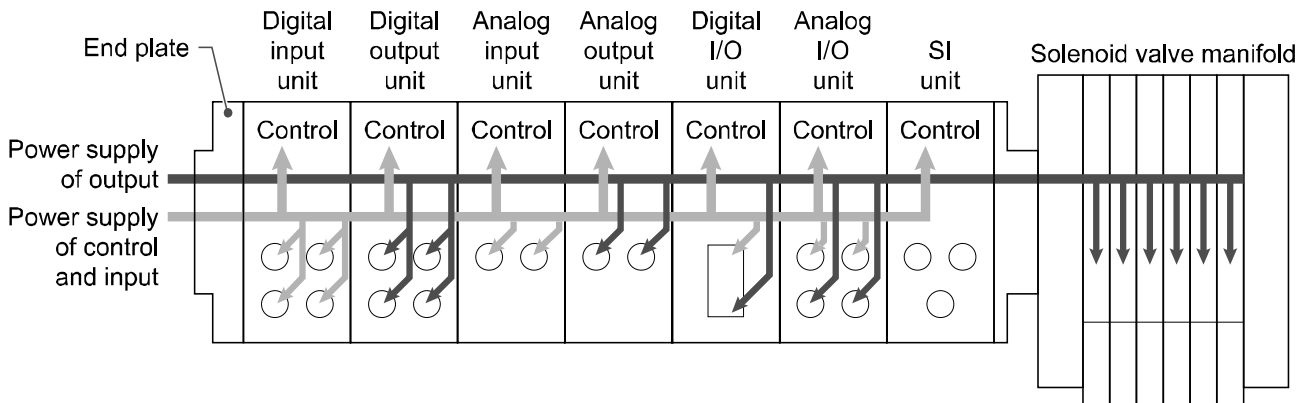

●Precautions for handling

Be sure to fit a seal cap on any unused connectors. Proper use of the seal cap enables the enclosure to achieve IP67 specification.

Specification

■ Specifications

Model		EX600-ED2-□	EX600-ED3-□
Power specifications	Power connector	M12 (5 pin) Plug	7/8 inch (5 pin) Plug
	Power supply (Control and input)	24 VDC ±10% Class2, 2 A	24 VDC ±10%, 8 A
	Power supply (Output)	24 VDC +10/-5% Class2, 2 A	24 VDC +10/-5%, 8 A
Environment	Enclosure	IP67 (With manifold assembled) ^{*1}	
	Operating temperature range	-10 to 50 °C (Max. surrounding air temperature rating: 50 °C) ^{*2}	
	Storage temperature range	-20 to 60 °C	
	Operating humidity range	35 to 85%RH (No condensation)	
	Withstand voltage	500 VAC for 1 minute between external terminals and FE	
	Insulation resistance	500 VDC, 10 MΩ min. between external terminals and FE	
	Pollution degree	For use in Pollution Degree 3 Environment (UL508)	
Standard	CE marking, UL recognition (CSA), RoHS		
Weight	170 g	175 g	

*1: All unused connectors must have a seal cap fitted.

*2: The UL agreement temperature is 0 to 50 °C.

■ Dimensions

•EX600-ED2-□

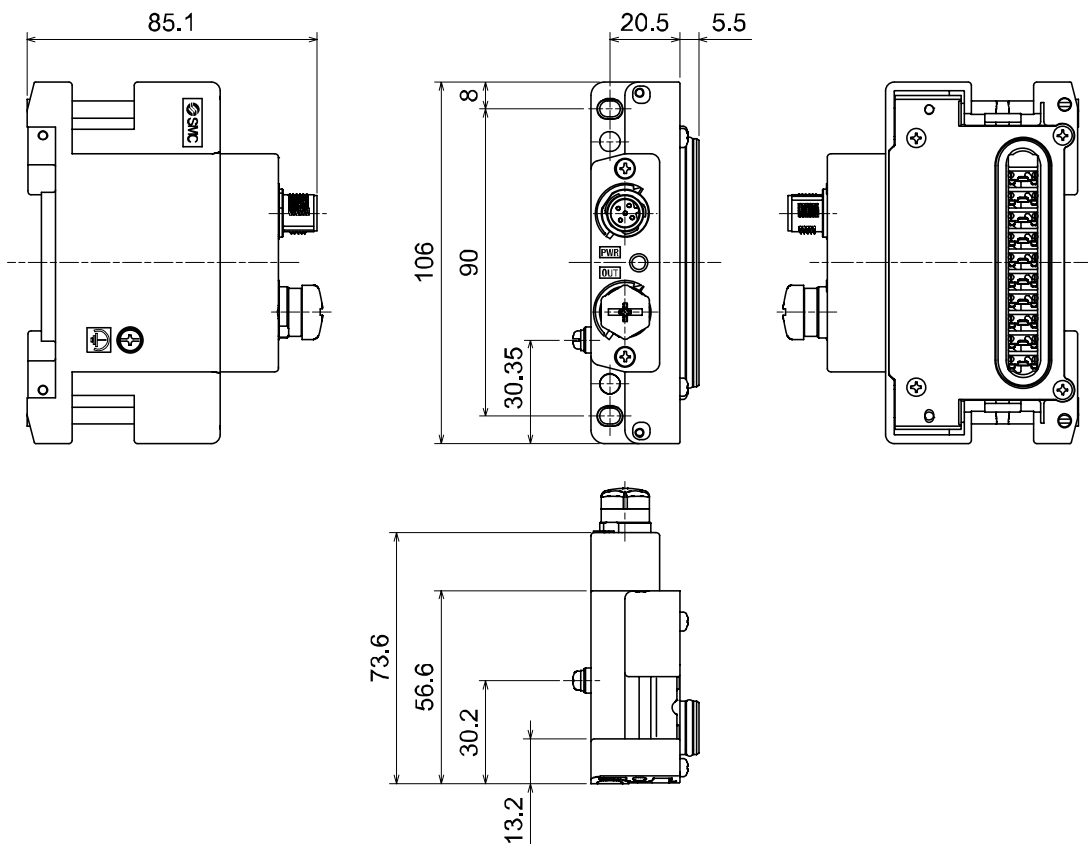

•EX600-ED3-□

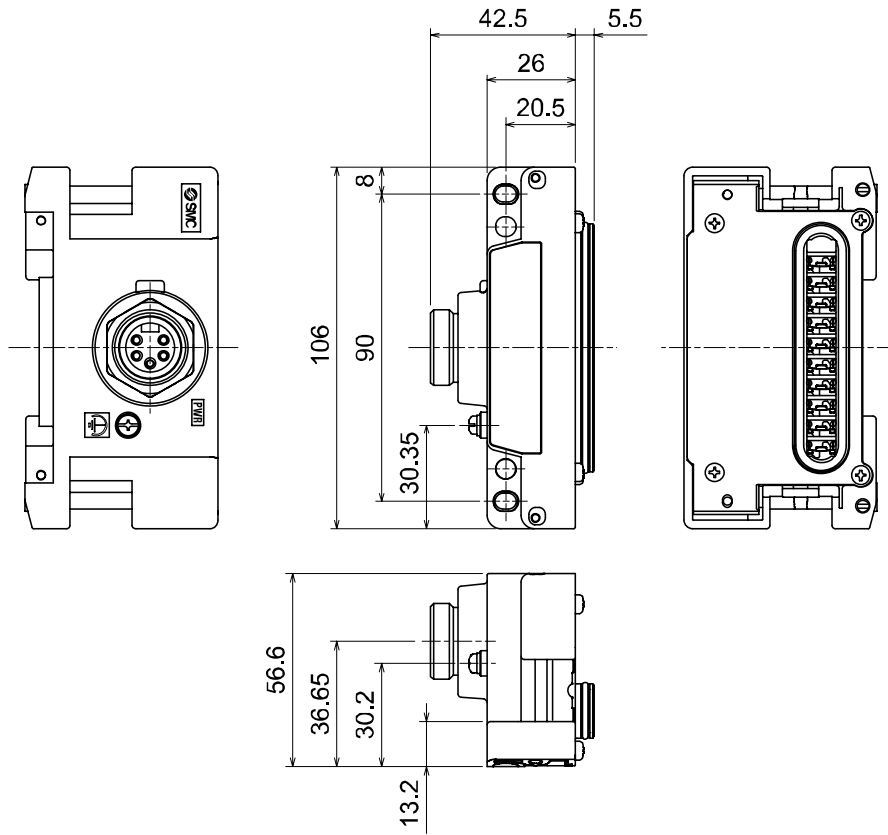

Maintenance

Turn off the power supply, stop the supplied air, exhaust the residual pressure and verify the release of air before performing maintenance.

Cleaning method

Use a soft cloth to remove stains.

For heavy stains, use a cloth soaked with diluted neutral detergent and fully squeezed, then wipe up the stains again with a dry cloth.

Do not use solvents such as benzene, thinner etc. to clean each unit.

Inspection item	Content of inspection
Connector/Electric wiring	Connect properly if the connection is loose.
Seal cap	Tighten properly if the connection is loose.
Thread for mounting and installation	If the thread is loose, re-tighten it to the specified torque.
Connection cables	If the cable is broken or any other abnormality is confirmed by appearance, replace the cable with a new one.
Supply source voltage	Check if source voltage within the specification range (24 VDC \pm 10%) is supplied.

How to reset the product for power cut or forcible de-energizing

Supply power to the product.

The output status just before the power failure is not maintained when power supply is recovered.

Start operation after confirming safety of the entire equipment.

Troubleshooting

•Troubleshooting

When any failure happens with this fieldbus system, the following chart is used to identify the cause of the failure.

Error status is reflected from the parameter setting of the fieldbus system.

When a failure occurs, take the appropriate countermeasures referring to the LED display, the troubleshooting and the parameter setting.

If a cause applicable to the failure cannot be identified, it indicates that the fieldbus system itself is broken. The fieldbus system breakage can be caused by the operating environment. Contact SMC separately to obtain countermeasures.

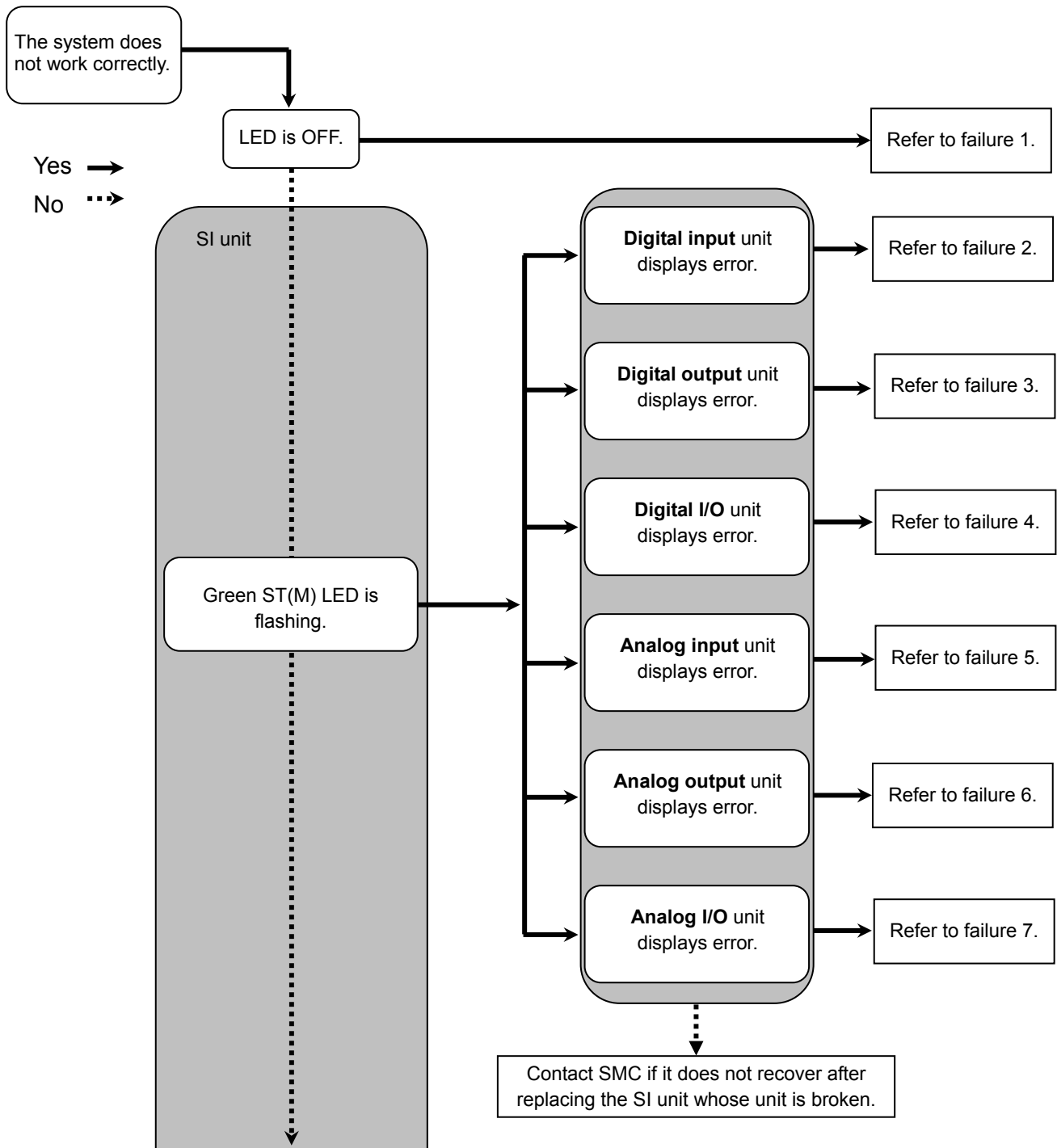

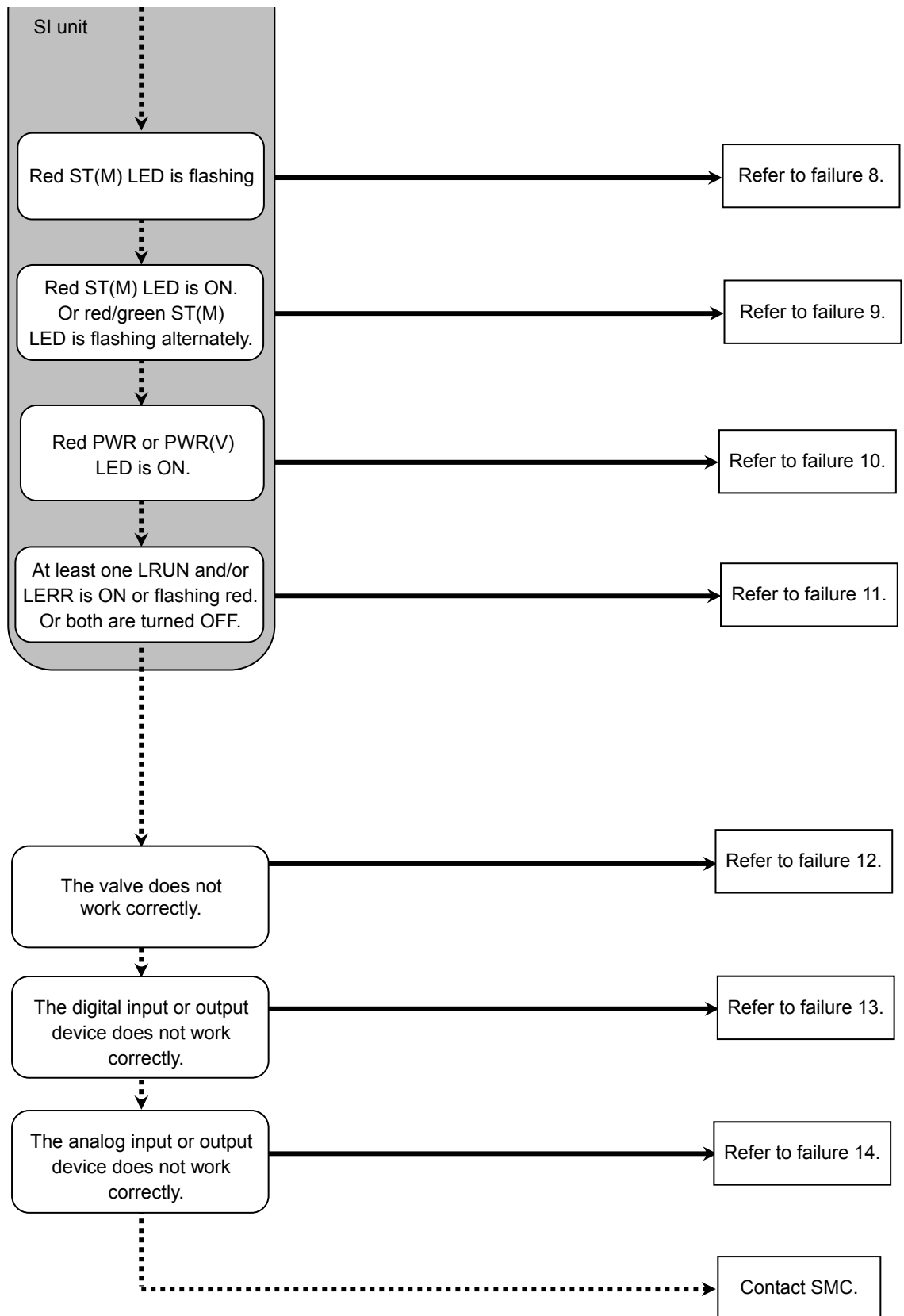

•Trouble counter measure method

No.	Part No. EX600-	Problem	Presumed cause	Troubleshooting
1	-	LED is OFF.	Power supply for control and input is OFF.	Check if the power for control and input is supplied.
2	DX□B DX□C□ DX□D	Red LED is ON. (Diagnosis is activated)	Diagnosis error Input device power supply is short-circuited.	Check the parts with error by using the LED display or PLC* or H.T. Re-wire the short-circuited part or check if the cable and input device are normal.
		Red LED is flashing. (Diagnosis is activated)	Diagnosis error (1)ON/OFF count of the input device has exceeded the set value. (2)The wire of the input device is broken or disconnected. (Only EX600-DX□C1)	Check the parts with error by using the LED display or PLC* or H.T. (1)Reset the ON/OFF count to zero or change the set value. Or invalidate diagnosis. (2)Check if the connector is loose and if the wire is broken.
		Red/green all LEDs are flashing.	Unit has failed.	Stop the operation and contact SMC.
	DX□E DX□F	Red ST LED is ON. (Diagnosis is activated)	Diagnosis error Input device power supply is short-circuited.	Check the parts with error by using the LED display or PLC* or H.T. Re-wire the short-circuited part or check if the cable and input device are normal.
		Red ST LED is flashing. (Diagnosis is activated)	Diagnosis error ON/OFF count of the input device has exceeded the set value.	Check the parts with error by using the LED display or PLC* or H.T. Reset the ON/OFF count to zero or change the set value. Or invalidate diagnosis.
		Red/green ST LED is flashing.	Unit has failed.	Stop the operation and contact SMC.

*: Refer to "System diagnosis" (page 60) for the further details.

No.	Part No. EX600-	Problem	Presumed cause	Troubleshooting
3	DY□B	Red LED is ON. (Diagnosis is activated)	Diagnosis error Output device is short-circuited.	Check the parts with error by using the LED display or PLC* or H.T. Re-wire the short-circuited part or check if the cable and output device are normal.
		Red LED is flashing. (Diagnosis is activated)	Diagnosis error (1)ON/OFF count of the output device has exceeded the set value. (2)The wire of the output device is broken or disconnected.	Check the parts with error by using the LED display or PLC* or H.T. (1)Reset the ON/OFF count to zero or change the set value. Or invalidate diagnosis. (2)Check if the connector is loose and if the wire is broken.
		Red/green all LEDs are flashing.	Unit has failed.	Stop the operation and contact SMC.
	DY□E DY□F	Red ST LED is ON. (Diagnosis is activated)	Diagnosis error Output device is short-circuited.	Check the parts with error by using the LED display or PLC* or H.T. Re-wire the short-circuited part or check if the cable and output device are normal.
		Red ST LED is flashing. (Diagnosis is activated)	Diagnosis error (1)ON/OFF count of the output device has exceeded the set value. (2)The wire of the output device is broken or disconnected.	Check the parts with error by using the LED display or PLC* or H.T. (1)Reset the ON/OFF count to zero or change the set value. Or invalidate diagnosis. (2)Check if the connector is loose and if the wire is broken.
		Red/green ST LED is flashing.	Unit has failed	Stop the operation and contact SMC.
4	DM□E DM□F	Red ST(I) LED is ON. (Diagnosis is activated)	Diagnosis error Input device power supply is short-circuited.	Check the parts with error by using the LED display or PLC* or H.T. Re-wire the short-circuited part or check if the cable and input device are normal.
		Red ST(I) LED is flashing. (Diagnosis is activated)	Diagnosis error ON/OFF count of the input device has exceeded the set value.	Check the parts with error by using the LED display or PLC* or H.T. Reset the ON/OFF count to zero or change the set value. Or invalidate diagnosis.
		Red ST(O) LED is ON. (Diagnosis is activated)	Diagnosis error Output device is short-circuited.	Check the parts with error by using the LED display or PLC* or H.T. Re-wire the short-circuited part or check if the cable and output device are normal.
		Red ST(O) LED is flashing (Diagnosis is activated)	Diagnosis error (1)ON/OFF count of the output device has exceeded the set value. (2)The wire of the output device is broken or disconnected.	Check the parts with error by using the LED display or PLC* or H.T. (1)Reset the ON/OFF count to zero or change the set value. Or invalidate diagnosis. (2)Check if the connector is loose and if the wire is broken.
		Red/green ST LED is flashing.	Unit has failed	Stop the operation and contact SMC.

*: Refer to "System diagnosis" (page 60) for the further details.

No.	Part No. EX600-	Problem	Presumed cause	Troubleshooting
5	AXA	Red LED is ON. (Diagnosis is activated)	Diagnosis error Analog input device power supply is short-circuited.	Check the parts with error by using the LED display or PLC* or H.T. Re-wire the short-circuited part, and check if the cable and analog input device are normal.
		"0 and 1" red LEDs are ON.	Input value has exceeded the upper limit when set to current input type range.	Check the following when the range of the analog input unit is set to current input. (1)Set the input value of the analog input device so that it does not exceed the upper limit. (2)Voltage is input from the analog input device. Ensure the range of the input unit matches the range of the input device.
		Red LED is flashing. (Diagnosis is activated)	Diagnosis error (1)Input value has exceeded the upper or lower limit of the range. (2)Input value (value set by user) has exceeded the upper or lower limit.	(1)If the input value from the analog input device exceeds the upper or lower limit of the range, select the appropriate range so that the input value is within the range. Or invalidate diagnosis. (2)If the input value from the analog input device exceeds the upper or lower limit of the user set value, adjust it so that the input value is within the range of the user set value. Or invalidate diagnosis.
		Red/green all LEDs are flashing.	Unit has failed	Stop the operation and contact SMC.
6	AYA	Red LED is ON. (Diagnosis is activated)	Diagnosis error Analog output device power supply is short-circuited.	Check the parts with error by using the LED display or PLC* or H.T. Re-wire the short-circuited part, and check if the cable and analog output device are normal.
		Red LED is flashing. (Diagnosis is activated)	Diagnosis error Output value (value set by user) has exceeded the upper or lower limit.	If the output value from the analog output device exceeds the upper or lower limit of the user set value, adjust it so that the output value is within the range of the user set value. Or invalidate diagnosis.
		Red/green all LEDs are flashing.	Unit has failed.	Stop the operation and contact SMC.

*: Refer to "System diagnosis" (page 60) for the further details.

No.	Part No. EX600-	Problem	Presumed cause	Troubleshooting
7	AMB	Red LED is ON. (Diagnosis is activated)	Diagnosis error Analog input or output device power supply is short-circuited.	Check the parts with error by using the LED display or PLC* or H.T. Re-wire the short-circuited part, and check if the cable and analog input or output device are normal.
		"0 and 1" red LEDs are ON.	Input value has exceeded the upper limit when set to Current input type range.	Check the following when the range of the analog input unit is set to current input. (1)Set the input value of the analog input device so that it does not exceed the upper limit. (2)Voltage is input from the analog input device. Ensure the range of the input unit matches the range of the input device.
		Red LED is flashing. (Diagnosis is activated)	Diagnosis error (1)Input value has exceeded the upper or lower limit of the range. (2)Input or output value (value set by user) has exceeded the upper or lower limit.	(1)If the input value from the analog input device exceeds the upper or lower limit of the range, select the appropriate range so that the input value is within the range. Or invalidate diagnosis. (2)If the input (output) value from the analog input (output) device exceeds the upper or lower limit of the user set value, adjust it so that the input (output) value is within the range of the user set value. Or invalidate diagnosis.
		Red/green all LEDs are flashing.	Unit has failed.	Stop the operation and contact SMC.
8		Red ST(M) LED is flashing. (Diagnosis is activated)	Diagnosis error (SI unit) (1)Valve is short-circuited. (2)Valve is open-circuited. (3)ON/OFF count of the valve has exceeded the set value.	Check the parts with error by using the LED display or PLC* or H.T. (1)Check the operation after replacing the valve. (2)Check the operation after replacing the valve. (3)Reset the ON/OFF count to zero or change the set value. Or invalidate diagnosis.
9		Red ST(M) LED is ON	SI unit has failed.	Stop the operation and contact SMC.
		Red/green ST(M) LED is flashing alternately.	(1)Connection between the units is defective. (2)Configuration memory error.	(1)Confirm that there is no loose connection between the units and connect them correctly. (2)Unit layout is not the same as the unit layout when it was memorized. Return the layout to the same as when it was memorized, or update the configuration memory, or turn off the configuration memory function.
10		Red PWR LED is ON. (Diagnosis is activated)	Power supply voltage for control and input is abnormal.	Supply 24 VDC \pm 10% for control and input power source.
		Red PWR(V) LED is ON. (Diagnosis is activated)	Power supply voltage for output is abnormal.	Supply 24 VDC +10/-5% for output power source.

*: Refer to "System diagnosis" (page 60) for the further details.

No.	Problem	Presumed cause	Troubleshooting
11	LRUN: OFF LERR: OFF	(1)CC-Link communication failure (2)PLC or SI unit malfunction	(1)Check the following points or reset, and then restart. <ul style="list-style-type: none"> •Make the same communication speed of PLC and SI unit. •Make the same CC-Link version / number of occupied stations of PLC and SI unit. •Use a cable of appropriate length. •Use the communication cable specified for CC-Link. •Ensure that the cable is not broken or loose. •Connect terminal resistors to both ends of the network. •Keep noise sources away from the communication line. (2)Replace the PLC or SI unit with a normal one, and check the operation.
	LRUN: OFF LERR: Red LED is flashing	The station number or communication speed setting switch has been changed during communication.	Cut the power supply and return the switch setting to its original condition, then supply power again.
	LRUN: OFF LERR: Red LED is ON	CC-Link communication error.	(1)Do not set the station number to "0" or over "65". Cut the power supply and reset the switch. (2)Do not set the communication speed switch out of the specification range. Cut the power supply and reset the switch. (3)Keep noise sources away from the communication line.

No.	Problem	Presumed cause	Troubleshooting
12	Abnormal valve operation	CC-Link version does not match.	Make the CC-Link version which is set by the operation mode switch match the PLC set version. If they do not match, turn off the power, then change the set version.
		The number of connected valves is larger than the number of occupied valve outputs.	When the number of occupied valves of the V_SEL switch is smaller than the number of connected valves, set the switch so that the number of occupied valves is not smaller than the number of valves to be used.
		Abnormality with program, etc.	Check if the ladder program of PLC, etc. is correct.
		Abnormal power supply for output.	Check if the green PWR(V) LED of the SI unit is ON. If the LED is OFF, or the red LED is ON, supply 24 VDC +10/-5% to the power supply for output.
		Connection between SI unit and manifold valve is defective.	Check the connectors between the SI unit and manifold valve are not damaged, such as bent pins, and connect them correctly.
		Polarity of output does not match.	IF the polarity of the SI unit and the valve are different, replace one of them to make the combination match. <ul style="list-style-type: none"> •EX600-SMJ1 (PNP output) ⇒ -common type valve •EX600-SMJ2 (NPN output) ⇒ +common type valve
		SI unit has failed.	Replace the SI unit with a normal one, and check the operation.
Valve failure.	Replace the valve with a normal one, and check the operation. Or refer to the troubleshooting of the valve used.		

No.	Problem	Presumed cause	Troubleshooting
13	Abnormal digital input device operation	CC-Link version does not match.	Make the CC-Link version which is set by the operation mode switch match the PLC set version. If they do not match, turn off the power, then change the set version.
		Polarity of input does not match.	If the polarity (PNP, NPN) of the input unit and the input device are different, replace one of them to make the combination match.
		Power supply for control and input is abnormal.	Check if the green PWR LED of the SI unit is ON. If the LED is OFF, or the red LED is ON, supply 24 VDC $\pm 10\%$ to the power supply for control and input.
		Wiring or connection is defective.	Connect the wiring correctly between the digital input device and the digital input unit.
		Input unit has failed.	Replace the input unit with a normal one, and check the operation.
		Input device failure.	Replace the input device with a normal one, and check the operation. Or refer to the troubleshooting of the input device used.
	Abnormal digital output device operation	CC-Link version does not match.	Make the CC-Link version which is set by the operation mode switch match the PLC set version. If they do not match, turn off the power, then change the set version.
		Polarity of output does not match.	If the polarity (PNP, NPN) of the output unit and the output device are different, replace one of them to make the combination match.
		Power supply for output is abnormal.	Check if the green PWR(V) LED of the SI unit is ON. If the LED is OFF, or the red LED is ON, supply 24 VDC $+10/-5\%$ to the power supply for output.
		Wiring or connection is defective.	Connect the wiring correctly between the digital output device and the digital output unit.
		Output unit has failed.	Replace the Output unit with a normal one, and check the operation.
		Output device failure.	Replace the output device with a normal one, and check the operation. Or refer to the troubleshooting of the output device used.
		Program etc. is defective.	Check whether the ladder program etc. of PLC are correct.

No.	Problem	Presumed cause	Troubleshooting
14	Abnormal analog input device operation	CC-Link version does not match.	Make the CC-Link version which is set by the operation mode switch match the PLC set version. If they do not match, turn off the power, then change the set version.
		Power supply for control and input is abnormal.	Check if the green PWR LED of the SI unit is ON. If the LED is OFF, or the red LED is ON, supply 24 VDC $\pm 10\%$ to the power supply for control and input.
		Analog input signal range setting failure.	Check the analog input device specification, and set the input signal range which satisfies the specification.
		Analog data format does not match.	Check whether the data format of the analog input unit is properly set.
		Wiring or connection is defective.	Connect the wiring correctly between the analog input device and the analog input unit.
		Analog input unit has failed.	Replace the analog input unit with a normal one, and check the operation.
		Analog input device failure.	Replace the analog input device with a normal one, and check the operation. Or refer to the troubleshooting of the analog input device used.
	Abnormal analog output device operation	CC-Link version does not match.	Make the CC-Link version which is set by the operation mode switch match the PLC set version. If they do not match, turn off the power, then change the set version.
		Power supply for output is abnormal.	Check if the green PWR(V) LED of the SI unit is ON. If the LED is OFF, or the red LED is ON, supply 24 VDC $+10/-5\%$ to the power supply for output.
		Analog output signal range setting failure.	Check the analog output device specification, and set the output signal range which satisfies the specification.
		Analog data format does not match.	Check whether the data format of the analog output unit is properly set.
		Wiring or connection is defective.	Connect the wiring correctly between the analog output device and the analog output unit.
		Analog output unit has failed.	Replace the analog output unit with a normal one, and check the operation.
		Analog output device failure.	Replace the analog output device with a normal one, and check the operation. Or refer to the troubleshooting of the analog output device used.
Program etc. is defective.	Check whether the ladder program etc. of PLC are correct.		

Parameter Setting

The product has parameters that can be set for the system, each unit or each channel.
The parameters can be changed using the PLC and Handheld Terminal.

- Precautions for handling
- Parameter setting by PLC is not possible for CC-Link.

■Parameter definition and setting

•System parameters

No.	Parameter (H.T. Symbol)	Definition	Item	Content	Default setting	Parameter setting	
						By PLC	By H.T.
1	Hold/Clear priority setting (Hold/Clear)	Switch the setting of the output during communication error to follow the setting of the SI unit or the Handheld Terminal.	Switch	Setting by SI unit switch becomes valid. OFF/Hold/Forced ON can be set per channel	○	×	○
			Handheld	Setting by the Handheld Terminal becomes valid. OFF/Hold/Forced ON can be set per channel.			

•SI unit parameters

No.	Parameter (H.T. Symbol)	Definition	Item	Content	Default setting	Parameter setting	
						By PLC	By H.T.
1	Power supply for control and input voltage monitor (PWRC_Mon)	Error is generated when control or input power supply voltage goes over approx. 26V or under 20V.	Enable	Enables.	○	×	○
			Disable	Disables.			
2	Power supply for output voltage monitor (PWRO_Mon)	Error is generated per unit when control or output power supply voltage goes over approx. 26V or under 21V.	Enable	Generates an error.	○	×	○
			Disable	Does not generate an error.			
3	Short Circuit Detection (SC_MonOp)	Generates error per unit when the short circuit of the valve is detected.	Enable	Generates an error.	○	×	○
			Disable	Does not generate an error.			
4	Restart after short circuit (SC_RstOp)	Restore the setting of short circuit detection error per unit after the valve short circuit is cleared.	Auto	Error is automatically cleared when the short circuit is fixed.	○	×	○
			Manual	Even when the short circuit is fixed, error is not cleared until the power is supplied again.			
5	Open Circuit Detection (OC_Mon)	Generates error per channel when the disconnection of the valve is detected.	Enable	Generates an error.		×	○
			Disable	Does not generate an error.	○		
6	Output setting during communication fault *1 (Fault_MD)	Set output per channel when communication is abnormal.	Clear	Turn off the output	○	×	○
			Hold	Hold the output			
			ForceON	Turn on the output forcefully			

No.	Parameter (H.T. Symbol)	Definition	Item	Content	Default setting	Parameter setting	
						By PLC	By H.T.
7	Valve ON/OFF counter (Counter)	Memorizes the number of times the valve is ON. Generates error per channel when the operation count exceeds the set value. *2	Enable	Generates an error. Val: 1 to 65000 *3		x	o
			Disable	Does not generate an error.	o		

*1: This function is valid only when "Hold/Clear priority" of the system parameter is set to Handheld.

*2: The count is memorized every 30 seconds per channel. When the power supply is turned on again, counting starts from the last value memorized.

*3: Times for setting is set value x1000 times.

•Digital input unit parameters

No.	Parameter (H.T. Symbol)	Definition	Item	Content	Default setting	Parameter setting	
						By PLC	By H.T.
1	The power supply short circuit detection for control and input (SC_MonSs)	Generates error per unit when the short circuit of the power supply for the input device is detected.	Enable	Generates an error.	○	×	○
			Disable	Does not generate an error.			
2	Open circuit detection *1 (OC_Mon)	Generates error per channel when the disconnection of the input device is detected. *2	Enable	Generates an error.		×	○
			Disable	Does not generate an error.	○		
3	Inrush current filter (Inrush)	Ignores excess current per unit for 100 msec after inrush.	Enable	Ignores excess current.		×	○
			Disable	Does not ignore excess current.	○		
4	Input filtering time (Filter_T)	Sets the time to ignore the input signal change per unit.	0.1 ms	Selects the time for filtering.	1.0 ms	×	○
			1.0 ms				
			10 ms				
			20 ms				
5	Input extension time (SigExt_T)	Sets the time to hold the input signal per unit.	1.0ms	Selects the time to hold the input signal.	15 ms	×	○
			15 ms				
			100 ms				
			200 ms				
6	Channel ON/OFF counter (Counter)	Memorizes the number of times the input device is ON. Generates error per channel when the operation count exceeds the set value. *3	Enable	Generates an error. Val: 1 to 65000 *4		×	○
			Disable	Does not generate an error.	○		

*1: Disconnection detection is a function only available for digital unit (EX600-DXPC1, EX600-DXNC1) with disconnection detection.

*2: 2-wire type input equipment cannot be correctly detected if its leakage current is 0.5 mA or less while the equipment is in the OFF state (reed sensor, etc.). Ensure that all input equipment used has a leakage current above 0.5 mA in the OFF state.

3-wire type input equipment cannot be correctly detected if its current consumption is 0.5mA or less. The open circuit of input signals cannot be detected.

*3: The count is memorized every hour. When the power supply is turned on again, counting starts from the last value memorized.

*4: Times for setting is set value x1000 times.

•Digital output unit parameters

No.	Parameter (H.T. Symbol)	Definition	Item	Content	Default setting	Parameter setting	
						By PLC	By H.T.
1	Output load short circuit detection (SC_MonOp)	Generates error per unit when the short circuit of the output device is detected. *1	Enable	Generates an error.	○	×	○
			Disable	Does not generate an error.			
2	Restart after output load short circuit (SC_RstOp)	Restore the setting of short circuit detection error per unit after the output device short circuit is cleared.	Auto	Error is automatically cleared when the short circuit is fixed.	○	×	○
			Manual	Even when the short circuit is fixed, error is not cleared until the power is supplied again.			
3	Open circuit detection (OC_Mon)	Generates error per channel when the disconnection of the output device is detected.	Enable	Generates an error.		×	○
			Disable	Does not generate an error.	○		
4	Output setting during communication fault *2 (Fault_MD)	Set output per channel when communication is abnormal.	Clear	Turn off the output	○	×	○
			Hold	Hold the output			
			ForceON	Turn on the output forcefully			
5	Output ON/OFF counter (Counter)	Memorizes the number of times the output device is ON. Generates error per channel when the operation count exceeds the set value. *3	Enable	Generates an error. Val: 1 to 65000 *4		×	○
			Disable	Does not generate an error.	○		

*1: Could be incorrectly recognized as short circuit depending on used load (ex.: lamp load). If detection is incorrect, disable the parameter setting.

*2: This function is valid only when "Hold/Clear priority" of the system parameter is set to Handheld.

*3: The count is memorized every hour. When the power supply is turned on again, counting starts from the last value memorized.

*4: Times for setting is set value x1000 times.

•Digital I/O unit parameters

No.	Parameter (H.T. Symbol)	Definition	Item	Content	Default setting	Parameter setting	
						By PLC	By H.T.
1	The power supply short circuit detection for control and input (SC_MonSs)	Generates error per unit when the short circuit of the control or input power supply is detected.	Enable	Generates an error.	○	×	○
			Disable	Does not generate an error.			
2	Inrush current filter (Inrush)	Ignores excess current per unit for 100 msec. after inrush.	Enable	Ignores excess current.		×	○
			Disable	Does not ignore excess current	○		
3	Input filtering time (Filter_T)	Sets the time to ignore the input signal change per unit	0.1 ms	Selects the time for filtering.	1.0 ms	×	○
			1.0 ms				
			10 ms				
			20 ms				
4	Input extension time (SigExt_T)	Sets the time to hold the input signal per unit.	1.0 ms	Selects the time to hold the input signal.	15 ms	×	○
			15 ms				
			100 ms				
			200 ms				
5	Output load short circuit detection (SC_MonOp)	Generates error per unit when the short circuit of the output device is detected. *1	Enable	Generates an error.	○	×	○
			Disable	Does not generate an error.			
6	Restart after output load short circuit (SC_RstOp)	Restore the setting of short circuit detection error per unit after the output device short circuit is cleared.	Auto	Error is automatically cleared when the short circuit is fixed.	○	×	○
			Manual	Even when the short circuit is fixed, error is not cleared until the power is supplied again.			
7	Open circuit detection (OC_Mon)	Generates error per channel when the disconnection of the output device is detected.	Enable	Generates an error.		×	○
			Disable	Does not generate an error.	○		
8	Output setting during communication fault *2 (Fault_MD)	Set output per channel when communication is abnormal.	Clear	Turn off the output	○	×	○
			Hold	Hold the output			
			ForceON	Turn on the output forcefully			

No.	Parameter (H.T. Symbol)	Definition	Item	Content	Default setting	Parameter setting	
						By PLC	By H.T.
9	Input or Output ON/OFF counter (Counter)	Memorizes the number of times the input or output device is ON. Generates error per channel when the operation count exceeds the set value. *3	Enable	Generates an error. Val: 1 to 65000 *4		×	○
			Disable	Does not generate an error.	○		

*1: Could be incorrectly recognized as short circuit depending on used load (ex.: lamp load). If detection is incorrect, disable the parameter setting.

*2: This function is valid only when "Hold/Clear priority" of the system parameter is set to Handheld.

*3: The count is memorized every hour. When the power supply is turned on again, counting starts from the last value memorized.

*4: Times for setting is set value x1000 times.

•Analog input unit parameters

No.	Parameter (H.T. Symbol)	Definition	Item	Content	Default setting	Parameter setting	
						By PLC	By H.T.
1	The power supply short circuit detection for the input device (SC_MonSs)	Generates error per unit when the short circuit of the power supply for the input device is detected.	Enable	Generates an error.	○	×	○
			Disable	Does not generate an error.			
2	Analog input range (Range)	Set the analog input device range per channel.	-10..10 V	Selects the analog input range.	-10..10 V	×	○
			-5..5 V				
			-20..20 mA				
			0..10 V				
			0.5 V				
			1.5 V				
			0..20 mA				
4..20 mA							
3	Analog data format (D_Format)	Sets analog data type which is output to PLC per unit.	Offset binary	Offset binary.	○	×	○
			Sign & Magnitude	Signed binary.			
			2S Complement	2's complement.			
4	Analog average filter (Filter)	Sets analog filtering time per channel. Sampling interval is approx. 2 sec.	None	None		×	○
			2AVG	2 value average	○		
			4AVG	4 value average			
5	Over range detection (Over_Rng)	Generates error per unit when the input value exceeds 0.5% of full span.	Enable	Generates an error.	○	×	○
			Disable	Does not generate an error.			
6	Under range detection (Undr_Rng)	Generates error per unit when the input value falls below 0.5% of full span.	Enable	Generates an error.	○	×	○
			Disable	Does not generate an error.			
7	User setting value upper limit error (Upr_Lmt)	Generates error per unit when the input value exceeds the set value.	Enable	Generates an error. *1		×	○
			Disable	Does not generate an error.	○		
8	User setting value lower limit error (Lwr_Lmt)	Generates error per channel when the input value falls below the set value.	Enable	Generates an error. *1		×	○
			Disable	Does not generate an error.	○		

*1: Set value shall be set per analog input range within settable range in the table below. When the analog input range is changed, check the set value and change it to an appropriate value.

Analog input measurement range. (Range)	Upper and lower setting limit of user setting.	
	(Lwr_Lmt)	(Upr_Lmt)
-10..10 V	-10.50 to +10.45 V	-10.45 to +10.50 V
-5..5 V	- 5.25 to + 5.22 V	- 5.22 to +5.25 V
-20..20 mA	-21.00 to +20.90 mA	-20.90 to +21.00 mA
0..10 V	0.00 to +10.45 V	+0.05 to +10.50 V
0..5 V	0.00 to +5.22 V	+0.03 to +5.25 V
1..5 V	+0.75 to +5.22 V	+0.78 to +5.25 V
0..20 mA	0.00 to +20.90 mA	+0.10 to +21.00 mA
4..20 mA	+3.00 to +20.90 mA	+3.10 to +21.00 mA

•Analog output unit parameters (1)

No.	Parameter (H.T. Symbol)	Definition	Item	Content	Default setting	Parameter setting	
						By PLC	By H.T.
1	The power supply short circuit detection for the output device (SC_MonSs)	Generates error per unit when the short circuit of the output device is detected.	Enable	Generates an error.	○	×	○
			Disable	Does not generate an error.			
2	Analog output range (Range)	Sets the range of the analog output device per channel.	0..10 V	Selects the analog output range.	0..10 V	×	○
			0..5 V				
			1..5 V				
			0..20 mA				
3	Analog data format (D_Format)	Sets analog data type which is output to PLC per unit.	Offset binary	Offset binary.	○	×	○
			Sign & Magnitude	Signed binary.			
			2S Complement	2's complement.			
			Scaled	Scale conversion type.			
4	User setting value upper limit error (Upr_Lmt)	Generates error per channel when the output value exceeds the set value.	Enable	Generates an error. *2		×	○
	Disable	Does not generate an error.	○				
4	Scale upper limit setting *1 (UpLm/ScI)	Sets the scale upper limit. Generates error per channel when the output value exceeds the upper limit.	Enable	Generates an error. Val: -32766 to 32767		×	○
			Disable	Does not generate an error. Val: -32766 to 32767	○ Val: 1000		
5	User setting value lower limit error (Lwr_Lmt)	Generates error per channel when the output value falls below the set value.	Enable	Generates an error. *2		×	○
	Disable	Does not generate an error.	○				
5	Scale lower limit setting *1 (LwLm/ScI)	Sets the scale lower limit. Generates error per channel when the output value falls below the lower limit.	Enable	Generates an error. Val: -32767 to 32766		×	○
			Disable	Does not generate an error. Val: -32767 to 32766	○ Val: 0		
6	Output setting for communication fault *3 (Fault_MA)	Set output per channel when communication is abnormal.	Enable	Val is output. *2		×	○
			Disable	The output is held.	○		

- *1: When "Scaled" is selected as the analog data format, the display of H.T. is switched from Upr_Lmt to UpLm/Scl, from Lwr_Lmt to LwLm/Scl.
- *2: Set value shall be set per analog input range within settable range in the table below. When the analog input range is changed, check the set value and change it to an appropriate value.
- *3: This function is valid only when "Hold/Clear priority" of the system parameter is set to Handheld.

Analog output measurement range. (Range)	Upper and lower setting limit of user setting.		Settable range during communication fault. (Fault_MA)
	(Lwr_Lmt)	(Upr_Lmt)	
0..10 V	0.00 to +10.45 V	+0.05 to +10.50 V	0.00 to +10.50 V
0..5 V	0.00 to + 5.22 V	+0.03 to +5.25 V	0.00 to +5.25 V
1..5 V	+0.75 to +5.22 V	+0.78 to +5.25 V	+0.75 to +5.25 V
0..20 mA	0.00 to +20.90 mA	+0.10 to +21.00 mA	0.00 to +21.00 mA
4..20 mA	+3.00 to +20.90 mA	+3.10 to +21.00 mA	+3.00 to +21.00 mA

•Analog I/O unit parameters (1)

No.	Parameter (H.T. Symbol)	Definition	Item	Content	Default setting	Parameter setting	
						By PLC	By H.T.
1	The power supply short circuit detection for the input or output device (SC_MonSs)	Generates error per unit when the short circuit of the input device power supply or output device is detected.	Enable	Generates an error.	○	×	○
			Disable	Does not generate an error.			
2	Analog input or output range (Range)	Sets the analog input or output device range per channel.	0..10 V	Selects the analog input or output range.	1.5 V	×	○
			0..5 V				
			1..5 V				
			0..20 mA				
			4..20 mA				
3	Analog data format (D_Format)	Sets analog data type which is output to PLC per unit.	Offset binary	Offset binary.	○	×	○
			Sign & Magnitude	Signed binary.			
			2S Complement	2's complement.			
			Scaled	Scale conversion type.			
4	Analog average filter (Filter)	Sets analog filtering time per channel. Sampling interval is approx. 2 sec.	None	None	○	×	○
			2AVG	2 value average			
			4AVG	4 value average			
			8AVG	8 value average			
5	Over range detection (Over_Rng)	Generates error per unit when the input value exceeds 0.5% of full span.	Enable	Generates an error.		×	○
			Disable	Does not generate an error.	○		
6	Under range detection (Undr_Rng)	Generates error per unit when the input value falls below 0.5% of full span.	Enable	Generates an error.		×	○
			Disable	Does not generate an error.	○		
7	User's set value upper limit error (Upr_Lmt)	Generates error per channel when the input or output value exceeds the set value.	Enable	Generates an error. *2	○	×	○
			Disable	Does not generate an error.			
	Scale upper limit setting *1 (UpLm/Scl)	Sets the scale upper limit. Generates error per channel when the input or output value exceeds the upper limit.	Enable	Generates an error. Val: -32766 to 32767	○ Val: 1000		
			Disable	Does not generated an error. Val: -32766 to 32767			

•Analog I/O unit parameters (2)

No.	Parameter (H.T. Symbol)	Definition	Item	Content	Default setting	Parameter setting	
						By PLC	By H.T.
8	User's set value lower limit error (Lwr_Lmt)	Generates error per channel when the input or output value falls below the lower limit.	Enable	Generates an error. *2		×	○
			Disable	Does not generate an error.	○		
	Scale lower limit setting *1 (UpLm/Scl)	Sets the scale lower limit. Generates error per channel when the input or output value falls below the lower limit.	Enable	Generates an error. Val: -32767 to 32766			
			Disable	Does not generate an error. Val: -32767 to 32766	○ Val: 0		
9	Output setting for communication fault *3 (Fault_MA)	Set output per channel when communication is abnormal.	Enable	Val is output. *2		×	○
			Disable	The output is held.	○		

*1: When "Scaled" is selected as the analog data format, the display of H.T. is switched from Upr_Lmt to UpLm/Scl, from Lwr_Lmt to LwLm/Scl.

*2: Set value shall be set per analog input/output range within settable range in the table below.

When the analog output range is changed, check the set value and change it to an appropriate value.

*3: This function is valid only when "Hold/Clear priority" of the system parameter is set to Handheld.

Analog Input or output measurement range. (Range)	Upper and lower setting limit of user setting.		Settable range during communication fault (Fault_MA)
	(Lwr_Lmt)	(Upr_Lmt)	
0..10 V	0.00 to +10.45 V	+0.05 to +10.50 V	0.00 to +10.50 V
0.5 V	0.00 to +5.22 V	+0.03 to +5.25 V	0.00 to +5.25 V
1.5 V	+0.75 to +5.22 V	+0.78 to +5.25 V	+0.75 to +5.25 V
0..20 mA	0.00 to +20.90 mA	+0.10 to +21.00 mA	0.00 to +21.00 mA
4..20 mA	+3.00 to +20.90 mA	+3.10 to +21.00 mA	+3.00 to +21.00 mA

I/O Map

The table below shows the occupied area for input/output of each unit of EX600.

Unit name	Unit part number	Occupied area			
		Bit area		Word area	
		Input (RX)	Output (RY)	Input (RWr)	Output (RWw)
SI unit	EX600-SMJ□ (32 output)	-	32 bit	-	-
	EX600-SMJ□ (24 output)	-	24 bit	-	-
	EX600-SMJ□ (16 output)	-	16 bit	-	-
	EX600-SMJ□ (8 output)	-	8 bit	-	-
Digital input unit	EX600-DX□B	8 bit	-	-	-
	EX600-DX□C	8 bit	-	-	-
	EX600-DX□C1 (With open circuit detection)	8 bit	-	-	-
	EX600-DX□D	16 bit	-	-	-
	EX600-DX□E	16 bit	-	-	-
	EX600-DX□F	16 bit	-	-	-
Digital output unit	EX600-DY□B	-	8 bit	-	-
	EX600-DY□E	-	16 bit	-	-
	EX600-DY□F	-	16 bit	-	-
Digital I/O unit	EX600-DM□E	8 bit	8 bit	-	-
	EX600-DM□F	8 bit	8 bit	-	-
Analog input unit	EX600-AXA	-	-	2 word (1 word per channel)	-
Analog output unit	EX600-AYA	-	-	-	2 word (1 word per channel)
Analog I/O unit	EX600-AMB	-	-	2 word (1 word per channel)	2 word (1 word per channel)

*: Number of occupied valve outputs of EX600-SMJ□ can be changed by the switch.

•I/O map assignment

I/O map of EX600 is assigned in order starting from the unit on the end plate side.

Taking the unit layout below as an example, the input/ output map is shown below.

	Unit 0	Unit 1	Unit 2	Unit 3	Unit 4	Unit 5	
End plate	AXA	AMB	DY□B	DX□B	DX□D	SMJ□	Valve
	Analog input	Analog output	Digital output	Digital input	Digital input	SI unit (32 output)	
	2 word Input	2 word Output	8 bit Output	8 bit Input	16 bit Input	32bit Output	

Unit No.	Unit part number	Input / Output map			
		Bit area		Word area	
		RX	RY	RWr	RWw
Unit 0	Analog input unit (EX600-AXA)	-	-	2 word	-
Unit 1	Analog output unit (EX600-AMB)	-	-	-	2 word
Unit 2	Digital output unit (EX600-DY□B)	-	8 bit	-	-
Unit 3	Digital input unit (EX600-DX□B)	8 bit	-	-	-
Unit 4	Digital input unit (EX600-DX□D)	16 bit	-	-	-
Unit 5	SI unit (EX600-SMJ□)	-	32 bit	-	-
Total		24 bit	40 bit	2 word	2 word

Diagnostic

By changing the diagnosis switch, the diagnostic data shown below is assigned to the head of input word area of the input/output map. (Refer to “Setting and adjustment” for setting the switch)

Diagnosis mode	Diagnostic data	Diagnosis size	Diagnosis area
0	No diagnostic data	0 word	-
1	System diagnosis	2 word	RWr0-RWr1
2	System diagnosis + Unit diagnosis (Up to 10 units)	3 word	RWr0-RWr2
3	System diagnosis + Unit diagnosis (Up to 64 units)	6 word	RWr0-RWr5

*: Diagnosis mode 3 is a function for extension in the future. Do not use it now.

*: Channel diagnosis cannot be assigned to the diagnosis area of the input. Use a Handheld Terminal (H.T.) for monitoring.

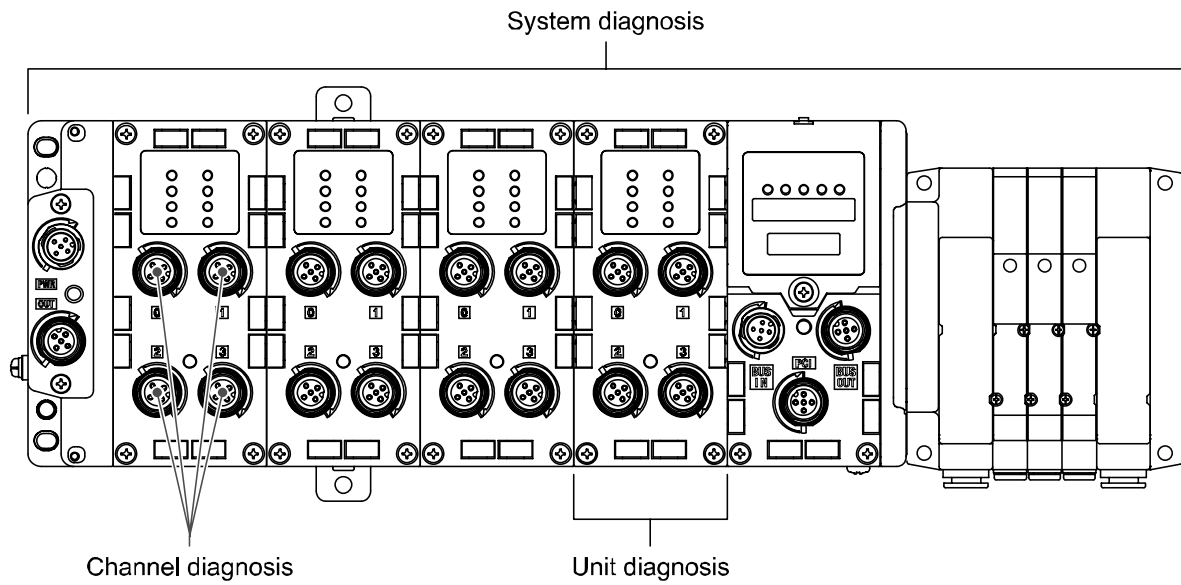

■Details of diagnostic data

•System diagnosis (RWr0 to RWr1)

Register	Bit No.	Content of diagnosis
RWr0	0	The power supply for output device is outside of the specification.
	1	The power supply for control and input device is outside of the specification.
	2	Reserved
	3	There is a connection failure between each unit (During operation).
	4	There is a connection failure between each unit (When the power supply is applied).
	5	Configuration memory error occurred.
	6	System error occurred.
	7	Hardware error occurred.
	8	The analog value has fallen below the user's set value.
	9	The analog value has exceeded the user's set value.
	10	The analog input value has fallen below the set range.
	11	The analog input value has exceeded the set range.
	12	The counter has exceeded the set value.
	13	The open circuit has been detected.
	14	The short circuit of the valve output or digital output has been detected.
15	The short circuit of the power supply for the input/output device has been detected.	
RWr1	0	There is an error in the digital input unit.*1
	1	There is an error in the digital output unit.*1
	2	There is an error in the analog input unit.*2
	3	There is an error in the analog output unit.*2
	4	There is an error in the SI unit.
	5	Reserved
	:	:
	15	Reserved

*1: When the error occurs in the digital I/O unit, both Bit0 and Bit1 are turned on.

*2: When the error occurs in the analog I/O unit, both Bit2 and Bit3 are turned on.

•Unit diagnosis (RWr2)

Register	Bit No.	Content of diagnosis
RWr2	0	There is an error in unit 0.
	1	There is an error in unit 1.
	2	There is an error in unit 2.
	3	There is an error in unit 3.
	4	There is an error in unit 4.
	5	There is an error in unit 5.
	6	There is an error in unit 6.
	7	There is an error in unit 7.
	8	There is an error in unit 8.
	9	There is an error in unit 9.
	10	Reserved
	:	:
	15	Reserved

I/O map depends on the setting of operation mode and diagnosis mode. The tables below show examples.

•Operation mode 1 (Ver.1.10, 1 station is occupied)

Diagnosis invalid (Diagnosis mode 0 is selected)				Diagnosis valid (Diagnosis mode 1 is selected)							
Station 1	bit area		word area		Station 1	bit area		word area			
	RX	RY	RWr	RWw		RX	RY	RWr	RWw		
	I15..I0	O15..O0	0	AI0		AO0	I15..I0	O15..O0	0	System	AO0
	System area		1	AI1		AO1	System area		1	diagnosis	AO1
			2	AI2		AO2	2	AI2	AO2		
		3	AI3	AO3	3	AI3	AO3				
<p>I15..I0 : Digital input (16 inputs) O15..O0 : Digital output (16 outputs) AI3..AI0 : Analog input (4 channels) AO3..AO0: Analog output (4 channels)</p>											

•Operation mode 2 (Ver.1.10, 2 stations are occupied)

Diagnosis invalid (Diagnosis mode 0 is selected)				Diagnosis valid (Diagnosis mode 2 is selected)							
Station 1	bit area		word area		Station 1	bit area		word area			
	RX	RY	RWr	RWw		RX	RY	RWr	RWw		
	I15..I0	O15..O0	0	AI0		AO0	I15..I0	O15..O0	0	System +	AO0
	I31..I16	O31..O16	1	AI1		AO1	I31..I16	O31..O16	1	unit	AO1
			2	AI2		AO2	2	AI2	AO2	diagnosis	AO2
		3	AI3	AO3	3	AI0	AO3				
Station 2	bit area		word area		Station 2	bit area		word area			
	RX	RY	RWr	RWw		RX	RY	RWr	RWw		
	I47..I32	O47..O32	0	AI4		AO4	I47..I32	O47..O32	0	AI1	AO4
	System area		1	AI5		AO5	System area		1	AI2	AO5
			2	AI6		AO6	2	AI3	AO6		
		3	AI7	AO7	3	AI4	AO7				

•Operation mode 5 (Ver.2.00, 1 station is occupied, extended cyclic 4 times)

	Diagnosis invalid (Diagnosis mode 0 is selected)				Diagnosis valid (Diagnosis mode 1 is selected)						
1st division	Station 1	bit area		word area		bit area		word area			
		RX	RY	RWr	RWw	RX	RY	RWr	RWw		
		I15..I0	O15..O0	0	AI0	AO0	I15..I0	O15..O0	0	System diagnosis	AO0
				1	AI1	AO1			1		AO1
		2	AI2	AO2			2	AI0	AO2		
		3	AI3	AO3			3	AI1	AO3		
2nd division	Station 2	I31..I16		O31..O16		I31..I16		O31..O16			
				0	AI4	AO4			0	AI2	AO4
				1	AI5	AO5			1	AI3	AO5
				2	AI6	AO6			2	AI4	AO6
		3	AI7	AO7			3	AI5	AO7		
3rd division	Station 3	I47..I32		O47..O32		I47..I32		O47..O32			
				0	AI8	AO8			0	AI6	AO8
				1	AI9	AO9			1	AI7	AO9
				2	AI10	AO10			2	AI8	AO10
		3	AI11	AO11			3	AI9	AO11		
4th division	Station 4	System area		AI12		System area		AI10			
				0	AI12	AO12			0	AI10	AO12
				1	AI13	AO13			1	AI11	AO13
				2	AI14	AO14			2	AI12	AO14
		3	AI15	AO15			3	AI13	AO15		

•Operation mode 7 (Ver.2.00, 2 stations are occupied, extended cyclic 8 times)

		Diagnosis invalid (Diagnosis mode 0 is selected)				Diagnosis valid (Diagnosis mode 2 is selected)			
1st division	Station 1	bit area		word area		bit area		word area	
		RX	RY	RWr	RWw	RX	RY	RWr	RWw
		I15..I0	O15..O0	0	AI0	AO0	0	AI0	AO0
				1	AI1	AO1	1	System + unit diagnosis	AO1
			2	AI2	AO2	2		AO2	
			3	AI3	AO3	3	AI0	AO3	
	Station 2	I31..I16		O31..O16		I31..I16		O31..O16	
		I47..I32	O47..O32	0	AI4	AO4	0	AI1	AO4
				1	AI5	AO5	1	AI2	AO5
				2	AI6	AO6	2	AI3	AO6
				3	AI7	AO7	3	AI4	AO7
2nd division	Station 1	I63..I48		O63..O48		I63..I48		O63..O48	
					0	AI8	AO8	0	AI5
				1	AI9	AO9	1	AI6	AO9
				2	AI10	AO10	2	AI7	AO10
			3	AI11	AO11	3	AI8	AO11	
	Station 2	I79..I64		O79..O64		I79..I64		O79..O64	
		I95..I80	O95..O80	0	AI12	AO12	0	AI9	AO12
				1	AI13	AO13	1	AI10	AO13
				2	AI14	AO14	2	AI11	AO14
				3	AI15	AO15	3	AI12	AO15
		⋮				⋮			
8th division	Station 1	I351..I336		O351..O336		I351..I336		O351..O336	
					0	AI56	AO56	0	AI53
				1	AI57	AO57	1	AI54	AO57
				2	AI58	AO58	2	AI55	AO58
			3	AI59	AO59	3	AI56	AO59	
	Station 2	I367..I352		O367..O352		I367..I352		O367..O352	
		System area							
				0	AI60	AO60	0	AI57	AO60
				1	AI61	AO61	1	AI58	AO61
				2	AI62	AO62	2	AI59	AO62
				3	AI63	AO63	3	AI60	AO63

Accessories

For the selection of accessories, refer to the catalog.

(1) Valve plate

EX600-ZMV1

Enclosed parts: Round head screw (M4x6), 2 pcs.

Round head screw (M3x8), 4 pcs.

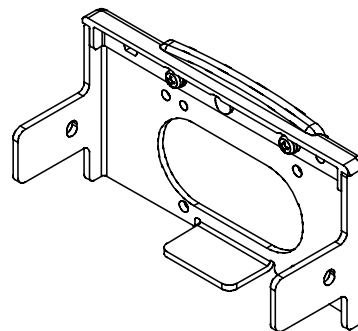

EX600-ZMV2 (Specified for SY series)

Enclosed parts: Round head screw (M4x6), 2 pcs.

Round head screw (M3x8), 4 pcs.

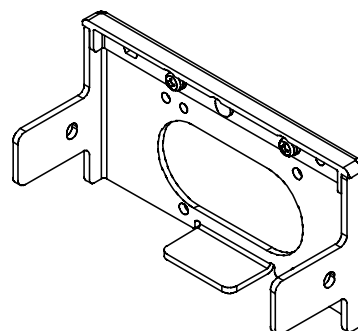

(2) End plate bracket

EX600-ZMA2

Enclosed parts: Round head screw (M4x20), 1 pc.

P tight screw (4x14), 2 pcs.

EX600-ZMA3 (Specified for SY series)

Enclosed parts: Round head screw (M4x20) with washer, 1 pc.

P tight screw (4x14), 2 pcs.

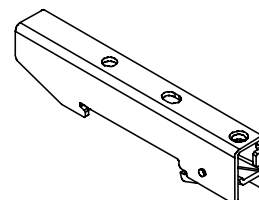

(3) Intermediate support bracket

EX600-ZMB1...for direct mounting

Enclosed parts: Round head screw (M4x5), 2 pcs.

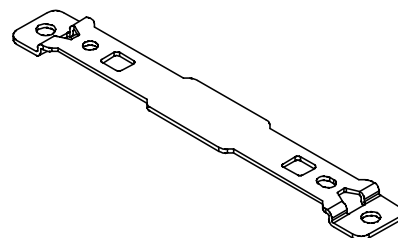

EX600-ZMB2...for DIN rail mounting

Enclosed parts: Round head screw (M4x6), 2 pcs.

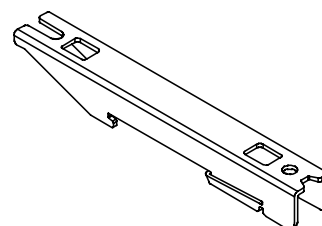

- (4) Seal cap (10 pcs.)
EX9-AWES...for M8
EX9-AWTS...for M12

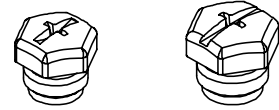

- (5) Marker (1 sheet, 88 pcs.)
EX600-ZT1

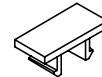

- (6) Y Junction connector
PCA-1557785 2xM12 (5 pin) – M12 (5 pin)

- (7) Assembled type connector
PCA-1578078 for power supply, 7/8 inch, Plug, Cable O.D. 12 to 14 mm
PCA-1578081 for power supply, 7/8 inch, Socket, Cable O.D. 12 to 14 mm
PCA-1557617 for CC-Link communication, Plug
PCA-1557620 for CC-Link communication, Socket
PCA-1557730 M8 (3 pin), Plug
PCA-1557743 M12 (4 pin), Plug, for AWG26 to AWG22, SPEEDCON compatible
PCA-1557756 M12 (4 pin), Plug, for AWG22 to AWG18, SPEEDCON compatible

- (8) Power supply cable
PCA-1558810 Cable with 7/8 inch connector, Socket, Straight 2 m
PCA-1558823 Cable with 7/8 inch connector, Socket, Straight 6 m
PCA-1558836 Cable with 7/8 inch connector, Socket, Right angle 2 m
PCA-1558849 Cable with 7/8 inch connector, Socket, Right angle 6 m
PCA-1564927 Cable with M12 connector, B code, Socket, Straight 2 m, SPEEDOCON compatible
PCA-1564930 Cable with M12 connector, B code, Socket, Straight 6 m, SPEEDOCON compatible
PCA-1564943 Cable with M12 connector, B code, Socket, Right angle 2 m, SPEEDOCON compatible
PCA-1564969 Cable with M12 connector, B code, Socket, Right angle 6 m, SPEEDOCON compatible

- (9) CC-Link communication cable
PCA-1567720 Cable with M12 connector, A code, Socket, Straight 5 m, SPEEDOCON compatible
PCA-1567717 Cable with M12 connector, A code, Plug, Straight 5 m, SPEEDOCON compatible

- (10) Connector extension cable
PCA-1557769 M12 (4 pin), Straight 3 m
PCA-1557772 M8 (3 pin), Straight 3 m

Revision history
A: Revision (Pollution degree)

SMC Corporation

4-14-1, Sotokanda, Chiyoda-ku, Tokyo 101-0021 JAPAN

Tel: +81 3 5207 8249 Fax: +81 3 5298 5362

URL <http://www.smcworld.com>

Note: Specifications are subject to change without prior notice and any obligation on the part of the manufacturer.
© 2010-2011 SMC Corporation All Rights Reserved

