



Operation Manual

PRODUCT NAME

Fieldbus system
Digital unit

MODEL / Series / Product Number

EX600-DX##
EX600-DY##
EX600-DM##

SMC Corporation

Table of Contents

Safety Instructions	3
System Outline	9
Assembly	10
Mounting and Installation	12
Installation	12
Wiring	14
<i>Digital input unit</i>	
Model Indication and How to Order	17
Names and Functions of Product	17
Mounting and Installation	20
Wiring	20
LED Display	25
Specification	28
Specifications	28
Dimensions	31
<i>Digital output unit</i>	
Model Indication and How to Order	34
Names and Functions of Product	34
Mounting and Installation	36
Wiring	36
LED Display	40
Specification	42
Specifications	42
Dimensions	44
<i>Digital I/O unit</i>	
Model Indication and How to Order	46
Names and Functions of Product	46
Mounting and Installation	48
Wiring	48
LED Display	52
Specification	54
Specifications	54
Dimensions	56



Common items

Maintenance	57
Troubleshooting	58
Parameter Setting	58
I/O Map	58
Diagnostic	58
Accessories	58
Precautions before mounting	59

Safety Instructions

These safety instructions are intended to prevent hazardous situations and/or equipment damage. These instructions indicate the level of potential hazard with the labels of "Caution", "Warning" or "Danger". They are all important notes for safety and must be followed in addition to International standards (ISO/IEC) *1) and other safety regulations.

- *1) ISO 4414: Pneumatic fluid power -- General rules relating to systems
- ISO 4413: Hydraulic fluid power -- General rules relating to systems
- IEC 60204-1: Safety of machinery -- Electrical equipment of machines (Part 1: General requirements)
- ISO 10218-1992: Manipulating industrial robots -Safety.
- etc.

-  **Caution** : CAUTION indicates a hazard with a low level of risk which, if not avoided, could result in minor or moderate injury.
-  **Warning** : WARNING indicates a hazard with a medium level of risk which, if not avoided, could result in death or serious injury.
-  **Danger** : DANGER indicates a hazard with a high level of risk which, if not avoided, will result in death or serious injury.

Warning

- 1. The compatibility of the product is the responsibility of the person who designs the equipment or decides its specifications.**

Since the product specified here is used under various operating conditions, its compatibility with specific equipment must be decided by the person who designs the equipment or decides its specifications based on necessary analysis and test results. The expected performance and safety assurance of the equipment will be the responsibility of the person who has determined its compatibility with the product. This person should also continuously review all specifications of the product referring to its latest catalog information, with a view to giving due consideration to any possibility of equipment failure when configuring the equipment.
- 2. Only personnel with appropriate training should operate machinery and equipment.**

The product specified here may become unsafe if handled incorrectly. The assembly, operation and maintenance of machines or equipment including our products must be performed by an operator who is appropriately trained and experienced.
- 3. Do not service or attempt to remove product and machinery/equipment until safety is confirmed.**
 1. The inspection and maintenance of machinery/equipment should only be performed after measures to prevent falling or runaway of the driven objects have been confirmed.
 2. When the product is to be removed, confirm that the safety measures as mentioned above are implemented and the power from any appropriate source is cut, and read and understand the specific product precautions of all relevant products carefully.
 3. Before machinery/equipment is restarted, take measures to prevent unexpected operation and malfunction.
- 4. Contact SMC beforehand and take special consideration of safety measures if the product is to be used in any of the following conditions.**
 1. Conditions and environments outside of the given specifications, or use outdoors or in a place exposed to direct sunlight.
 2. Installation on equipment in conjunction with atomic energy, railways, air navigation, space, shipping, vehicles, military, medical treatment, combustion and recreation, or equipment in contact with food and beverages, emergency stop circuits, clutch and brake circuits in press applications, safety equipment or other applications unsuitable for the standard specifications described in the product catalog.
 3. An application which could have negative effects on people, property, or animals requiring special safety analysis.
 4. Use in an interlock circuit, which requires the provision of double interlock for possible failure by using a mechanical protective function, and periodical checks to confirm proper operation.

Caution

The product is provided for use in manufacturing industries.

The product herein described is basically provided for peaceful use in manufacturing industries. If considering using the product in other industries, consult SMC beforehand and exchange specifications or a contract if necessary.
If anything is unclear, contact your nearest sales branch.

Limited warranty and Disclaimer/Compliance Requirements

The product used is subject to the following "Limited warranty and Disclaimer" and "Compliance Requirements".

Read and accept them before using the product.

Limited warranty and Disclaimer

1. The warranty period of the product is 1 year in service or 1.5 years after the product is delivered. *2)
Also, the product may have specified durability, running distance or replacement parts. Please consult your nearest sales branch.
2. For any failure or damage reported within the warranty period which is clearly our responsibility, a replacement product or necessary parts will be provided.
This limited warranty applies only to our product independently, and not to any other damage incurred due to the failure of the product.
3. Prior to using SMC products, please read and understand the warranty terms and disclaimers noted in the specified catalog for the particular products.

*2) Vacuum pads are excluded from this 1 year warranty.

A vacuum pad is a consumable part, so it is warranted for a year after it is delivered.

Also, even within the warranty period, the wear of a product due to the use of the vacuum pad or failure due to the deterioration of rubber material are not covered by the limited warranty.

Compliance Requirements

1. The use of SMC products with production equipment for the manufacture of weapons of mass destruction (WMD) or any other weapon is strictly prohibited.
2. The exports of SMC products or technology from one country to another are governed by the relevant security laws and regulation of the countries involved in the transaction. Prior to the shipment of a SMC product to another country, assure that all local rules governing that export are known and followed.

Operator

- ◆ This operation manual is intended for those who have knowledge of machinery using pneumatic equipment, and have sufficient knowledge of assembly, operation and maintenance of such equipment. Only those persons are allowed to perform assembly, operation and maintenance.
- ◆ Read and understand this operation manual carefully before assembling, operating or providing maintenance to the product.

■ Precautions

Warning

- Do not disassemble, modify (including changing the printed circuit board) or repair.
An injury or failure can result.
- Do not operate or set with wet hands.
This may lead to an electric shock.
- Do not operate the product outside of the specifications.
Do not use for flammable or harmful fluids.
Fire, malfunction, or damage to the product can result.
Verify the specifications before use.
- Do not operate in an atmosphere containing flammable or explosive gases.
Fire or an explosion can result.
This product is not designed to be explosion proof.
- If using the product in an interlocking circuit:
 - Provide a double interlocking system, for example a mechanical system.
 - Check the product regularly for proper operation.Otherwise malfunction can result, causing an accident.
- The following instructions must be followed during maintenance:
 - Turn off the power supply.
 - Stop the air supply, exhaust the residual pressure and verify that the air is released before performing maintenance.Otherwise an injury can result.

Caution

- When handling the unit or assembling/replacing units:
 - Do not touch the sharp metal parts of the connector or plug for connecting units.
 - Take care not to hit your hand when disassembling the unit.
The connecting portions of the unit are firmly joined with seals.
 - When joining units, take care not to get fingers caught between units.
An injury can result.
- After maintenance is complete, perform appropriate functional inspections.
Stop operation if the equipment does not function properly.
Safety cannot be assured in the case of unexpected malfunction.
- Provide grounding to assure the safety and noise resistance of the Fieldbus system.
Individual grounding should be provided close to the product with a short cable.

■ NOTE

- Follow the instructions given below when designing, selecting and handling the product.
- The instructions on design and selection (installation, wiring, environment, adjustment, operation, maintenance, etc.) described below must also be followed.
 - * Product specifications
 - The direct current power supply to combine should be UL 1310 Class2 power supply when conformity to UL is necessary.
 - Use the specified voltage.
Otherwise failure or malfunction can result.
 - The power supply for the unit should be 0V as the standard for both the power supply for outputs and the power supply for inputs and control.

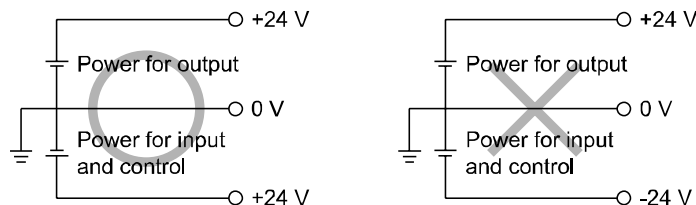

- Reserve a space for maintenance.
Allow sufficient space for maintenance when designing the system.
- Do not remove any nameplates or labels.
This can lead to incorrect maintenance, or misreading of the operation manual, which could cause damage or malfunction to the product.
It may also result in non-conformity to safety standards.
- Beware of inrush current when the power supply is turned on.
Some connected loads can apply an initial charge current which will activate the over current protection function, causing the unit to malfunction.

●Product handling

*Installation

- Do not drop, hit or apply excessive shock to the SI unit.
Otherwise damage to the product can result, causing malfunction.
- Tighten to the specified tightening torque.
If the tightening torque is exceeded the mounting screws may be broken.
IP67 protection cannot be guaranteed if the screws are not tightened to the specified torque.
- If a large manifold valve is mounted, lift the unit so that stress is not applied to the connecting part while transporting.
The stress may cause breakage of the connecting part. The unit may become very heavy depending on the combination. Transportation/installation shall be performed by multiple operators.
- Never mount a product in a location that will be used as a foothold.
The product may be damaged if excessive force is applied by stepping or climbing onto it.

*Wiring

- Avoid repeatedly bending or stretching the cables, or placing heavy load on them.
Repetitive bending stress or tensile stress can cause breakage of the cable.
- Wire correctly.
Incorrect wiring can break the product.
- Do not perform wiring while the power is on.
Otherwise damage to the SI unit and/or input or output device can result, causing malfunction.
- Do not route wires and cables together with power or high voltage cables.
Otherwise the SI unit and/or input or output device can malfunction due to interference of noise and surge voltage from power and high voltage cables to the signal line.
Route the wires (piping) of the SI unit and/or input or output device separately from power or high voltage cables.
- Confirm proper insulation of wiring.
Poor insulation (interference from another circuit, poor insulation between terminals, etc.) can lead to excess voltage or current being applied to the product, causing damage.
- Take appropriate measures against noise, such as using a noise filter, when the Fieldbus system is incorporated into equipment.
Otherwise noise can cause malfunction.

*Environment

- Select the proper type of protection according to the environment of operation.
IP67 protection is achieved when the following conditions are met.
 - (1)The units are connected properly with fieldbus cable with M12 connector and power cable with M12 (M8) connector.
 - (2)Suitable mounting of each unit and manifold valve.
 - (3)Be sure to fit a waterproof cap on any unused connectors.
If using in an environment that is exposed to water splashes, please take measures such as using a cover.
Do not use in an environment where moisture or water vapor are present. Otherwise failure and malfunction can result.
- Do not use in a place where the product could be splashed by oil or chemicals.
If the product is to be used in an environment containing oils or chemicals such as coolant or cleaning solvent, even for a short time, it may be adversely affected (damage, malfunction etc.).
- Do not use the product in an environment where corrosive gases or fluids could be splashed.
Otherwise damage to the product and malfunction can result.
- Do not use in an area where surges are generated.
If there is equipment generating large surge near the unit (magnetic type lifter, high frequency inductive furnace, welding machine, motor, etc.), this can cause deterioration of the internal circuitry element of the unit or result in damage. Take measures against the surge sources, and prevent the lines from coming into close contact.

- When a surge-generating load such as a relay, valve or lamp is driven directly, use a product with a built-in surge absorbing element.
Direct drive of a load generating surge voltage can damage the unit.
- The product is CE marked, but not immune to lightning strikes. Take measures against lightning strikes in the system.
- Prevent foreign matter such as dust or wire debris from getting inside the product.
- Mount the product in a place that is not exposed to vibration or impact.
Otherwise failure or malfunction can result.
- Do not use the product in an environment that is exposed to temperature cycle.
Heat cycles other than ordinary changes in temperature can adversely affect the inside of the product.
- Do not expose the product to direct sunlight.
If using in a location directly exposed to sunlight, shade the product from the sunlight.
Otherwise failure or malfunction can result.
- Keep within the specified ambient temperature range.
Otherwise malfunction can result.
- Do not operate close to a heat source, or in a location exposed to radiant heat.
Otherwise malfunction can result.

***Adjustment and Operation**

- Set the switches by using a sharp-pointed screwdriver etc. When setting the switch, do not touch other unrelated parts.
This can cause parts damage or malfunction due to a short circuit.
- Perform settings suitable for the operating conditions.
Incorrect setting can cause operation failure.
For details of each setting, refer to the SI unit Operation Manual.
- Please refer to the PLC manufacturer's manual etc. for details of programming and addresses.
For the PLC protocol and programming refer to the relevant manufacturer's documentation.

***Maintenance**

- Turn off the power supply, stop the supplied air, exhaust the residual pressure and verify the release of air before performing maintenance.
There is a risk of unexpected malfunction.
- Perform regular maintenance and inspections.
There is a risk of unexpected malfunction.
- After maintenance is complete, perform appropriate functional inspections.
Stop operation if the equipment does not function properly.
Otherwise safety is not assured due to an unexpected malfunction or incorrect operation.
- Do not use solvents such as benzene, thinner etc. to clean each unit.
They could damage the surface of the body and erase the markings on the body.
Use a soft cloth to remove stains.
For heavy stains, use a cloth soaked with diluted neutral detergent and fully squeezed, then wipe up the stains again with a dry cloth.

System Outline

•System configuration

The EX600 range of units can be connected to various types of Fieldbus to realize the reduction of input or output device wiring and the distributed control system. The unit communicates with the Fieldbus through the SI unit. One SI unit can be connected with manifold valves with up to 32 outputs and the input • output • I/O units with maximum 10 units.

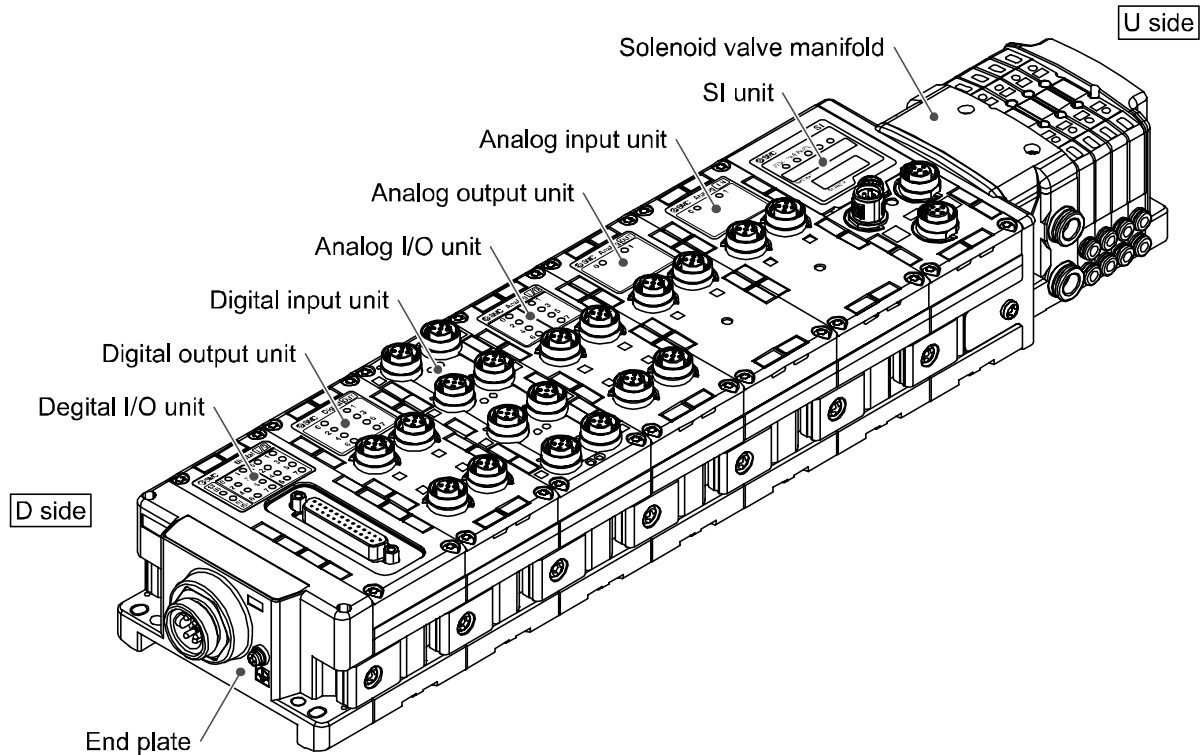

SI unit: Performs Fieldbus communication and solenoid valve manifold ON/OFF output.

Digital input unit: For connecting sensors with switch output capability. PNP and NPN types are available.

Digital output unit: For connecting output device such as solenoid valves, lamps, buzzers, etc. PNP and NPN types are available.

Digital I/O unit: This unit has both digital input and output functions. PNP and NPN types are available.

Analog input unit: For connecting sensors with analog output capability.

Analog output unit: This can be connected to the equipment which can read analog input.

Analog I/O unit: This unit has both analog input and output functions.

End plate: Connected at EX600 Manifold's D side, incorporating the power supply connection.

Solenoid valve manifold: An assembly of solenoid valves. One connector is used as the electric connection to all connected valves.

Assembly

•Composing the unit as a manifold

*: If the unit was purchased as a manifold, the work described in this section is not necessary.

(1)Connect the unit to the end plate.

The Digital unit, Analog unit can be connected in any order.

Tighten the bracket of the joint using tightening torque 1.5 to 1.6 Nm.

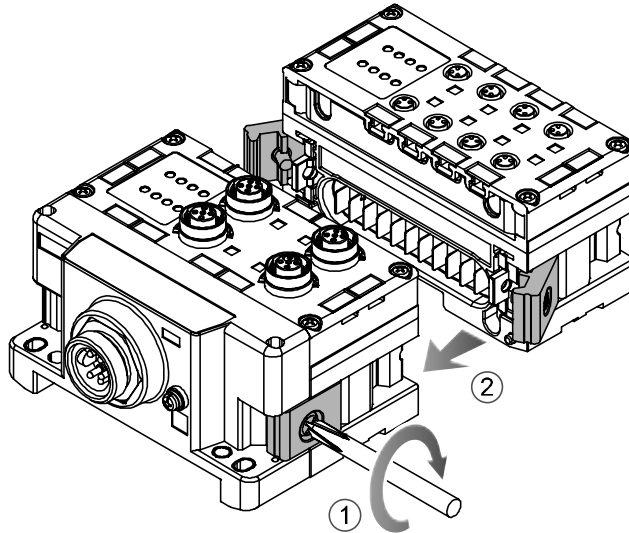

(2)Add more units.

Up to 10 units (including the SI unit) can be connected to one manifold.

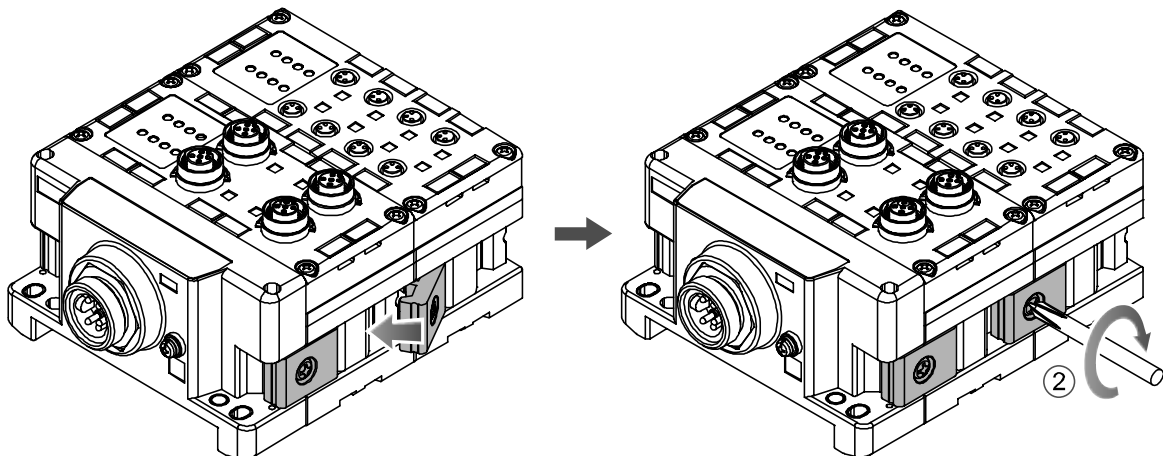

(3)Connecting the SI unit.

After connecting the necessary units, connect the SI unit.

Connecting method is the same as above (1), (2).

(4) Mounting the valve plate.

Mount the valve plate (EX600-ZMV□) to the valve manifold using the valve set screws. (M3x8)
Apply 0.6 to 0.7 Nm tightening torque to the screws.

Screw mounting place	
SV	: 2 places
S0700	: 2 places
VQC1000	: 2 places
VQC2000	: 3 places
VQC4000	: 4 places
SY	: 2 places

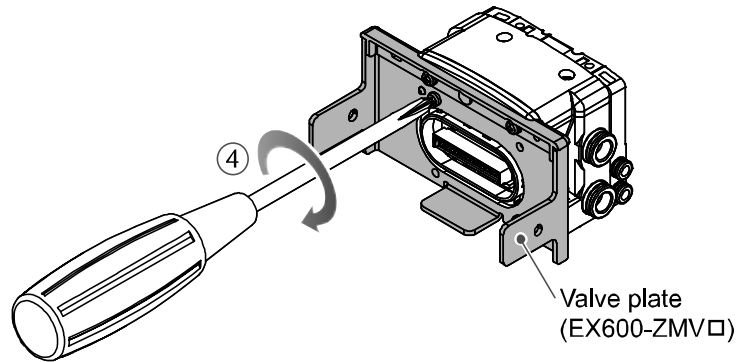

(5) Connect the SI unit and the valve manifold.

Insert the valve plate to the valve plate set groove on the side of SI unit.
Then, tighten it with the valve plate set screws (M4x6) to fix the plate.
Tightening torque for set screws 0.7 to 0.8 Nm.

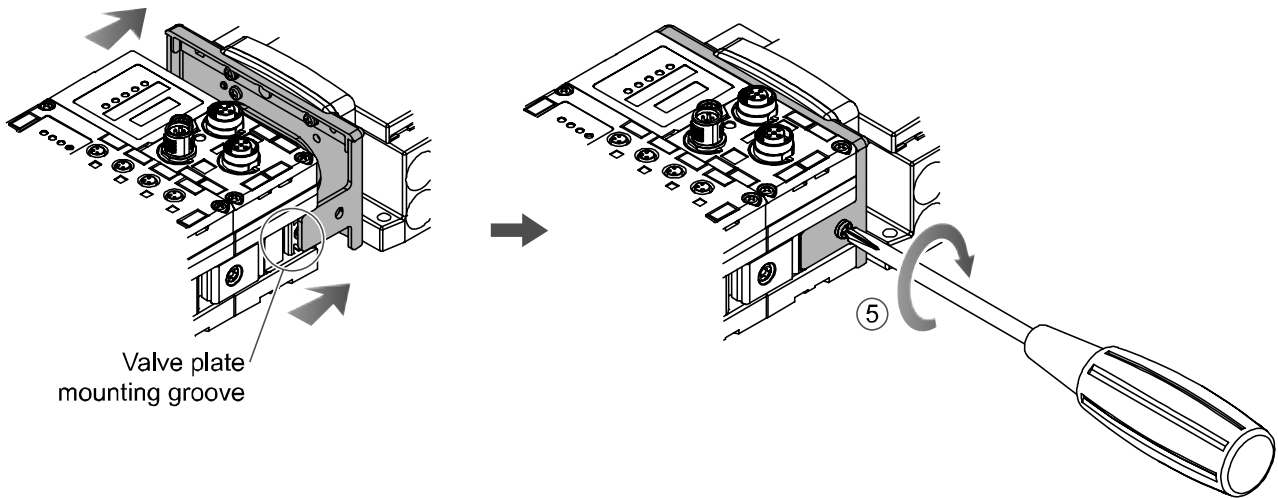

● Precautions for handling

- Please do not connect the unit while the power supply is active. It will cause equipment damage.
- Take care not to drop the nuts of Joint bracket.

Mounting and Installation

■ Installation

• Direct mounting

(1) When joining six or more units, fix the middle part of the complete EX600 unit with an intermediate reinforcing brace (EX600-ZMB1) before mounting using 2-M4x5 screws.

Tightening torque: 0.7 to 0.8 Nm.

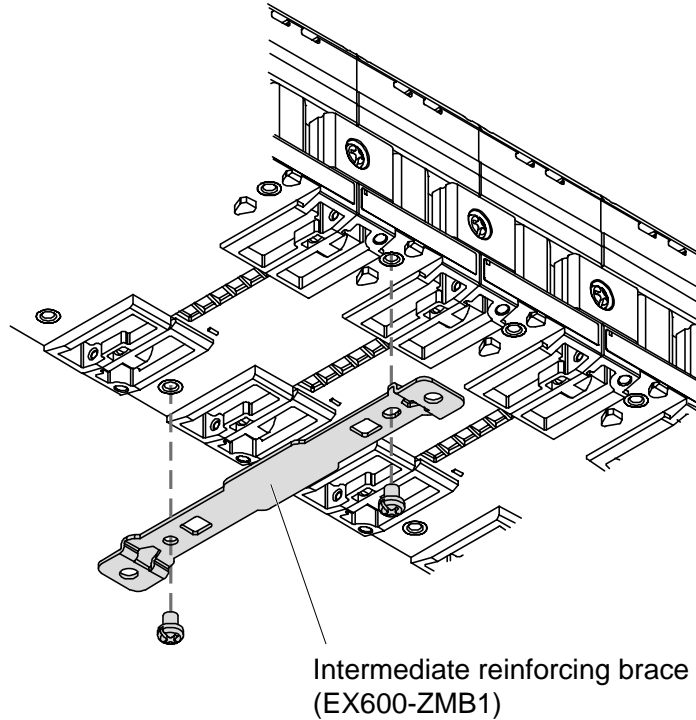

(2) Fix and tighten the end plates at one end of the unit. (M4)

Tightening torque: 0.7 to 0.8 Nm.

Fix the end plate at the valve side while referring to the operation manual of the corresponding valve manifold.

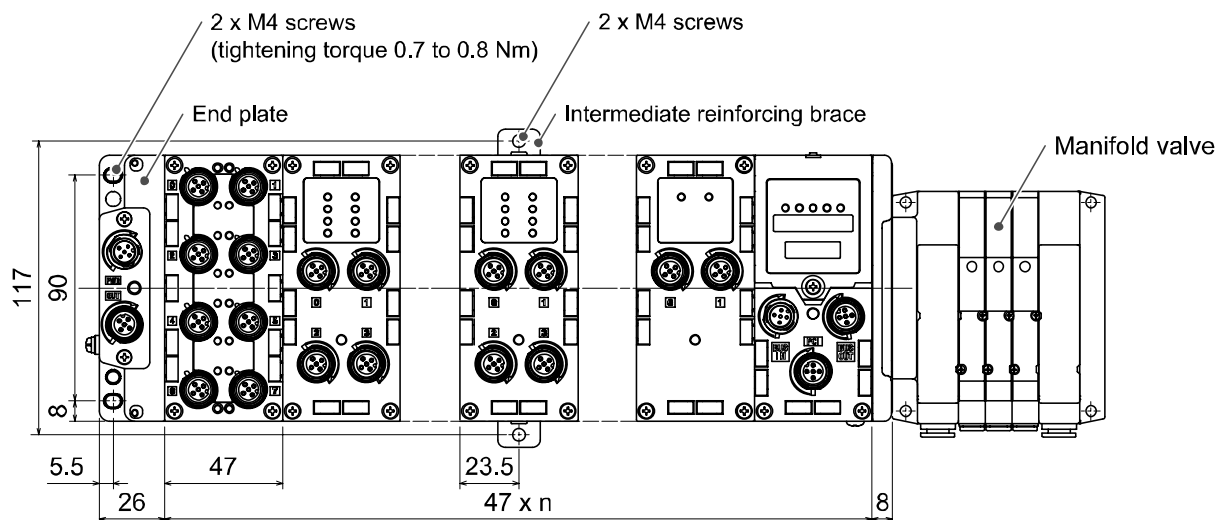

n (Number of connected units) 10

•DIN rail mounting

(Available for series other than SY series. Refer to the catalog for SY series.)

(1)When joining six or more units, fix the middle part of the complete EX600 unit with an intermediate reinforcing brace (EX600-ZMB2) before mounting, using 2-M4x6 screws.

Tightening torque: 0.7 to 0.8 Nm.

(2)Mount the end plate bracket (EX600-ZMA2) to the end plate at the opposite end to the valves, using 2-M4x14 screws.

Tightening torque: 0.7 to 0.8 Nm.

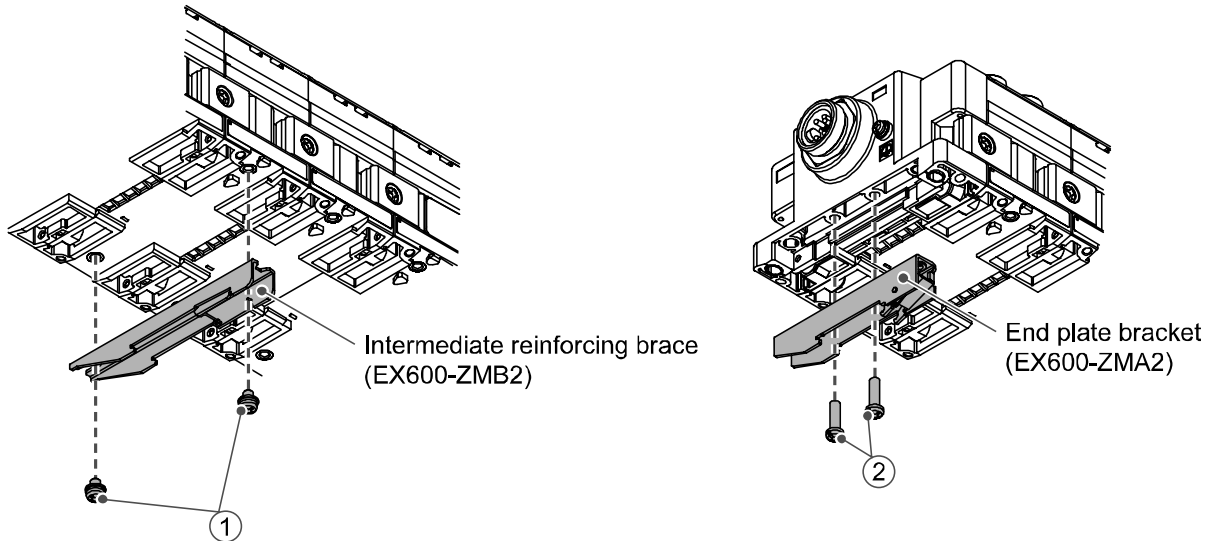

(3)Hook the DIN rail mounting groove to the DIN rail.

(4)Press the manifold using its side hooked to the DIN rail as a fulcrum until the manifold is locked.

(5)Fix the manifold by tightening the DIN rail fixing screws of the EX600-ZMA2. (M4x20)

Tightening torque: 0.7 to 0.8 Nm.

The tightening torque at the valve side depends on the valve type.

Refer to the operation manual of the corresponding valve manifold.

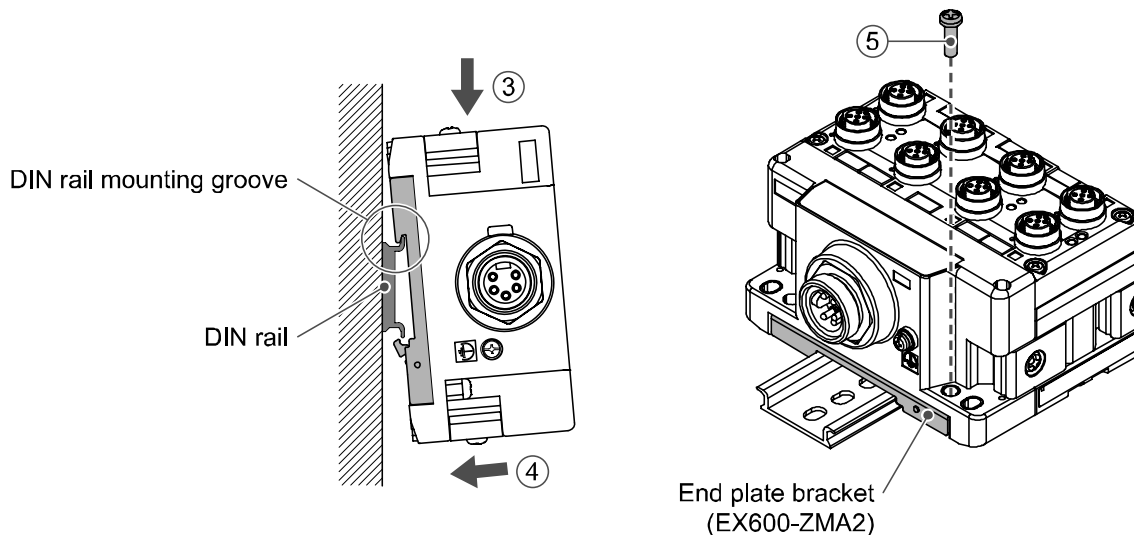

■Wiring

•Connect the M12 or M8 connector cable. M12 connector is applicable for SPEEDCON connector. SPEEDCON connector wiring method is explained below.

(1)Align the mark B on the metal bracket of the cable side connector (plug/socket) with the mark A.

(2)Align the mark C on the unit and insert the connector into the unit vertically.

If they are not aligned, the connector cannot be joined properly.

(3)When the mark B of the connector has been turned 180 degrees (1/2 turn), wiring is completed. Confirm that the connection is not loose. If turned too far, it will become hard to remove the connector.

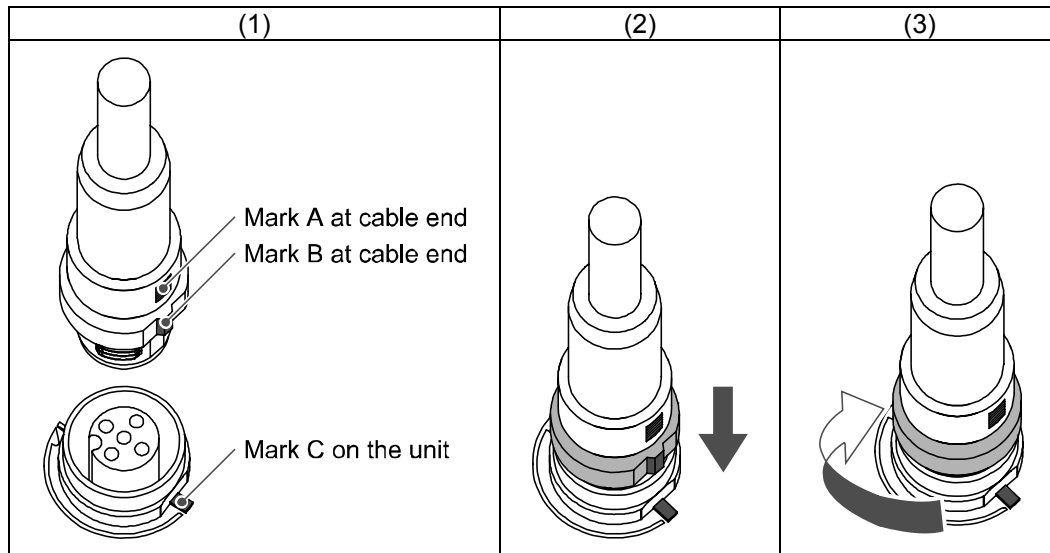

•D-sub socket connection method is explained below.

(1)Align the D-sub socket connector of the unit and the plug connector of the cable.

(2)Insert the plug connector of the cable into the D-sub socket connector of the unit vertically.

If the connector is pushed forcibly, the pin will bend and the connector cannot be joined.

(3)Fix the connector by tightening two No.4-40 UNC screws in the lock screw parts located at both ends of the connector of the unit. The tightening torque should be within 0.6 Nm.

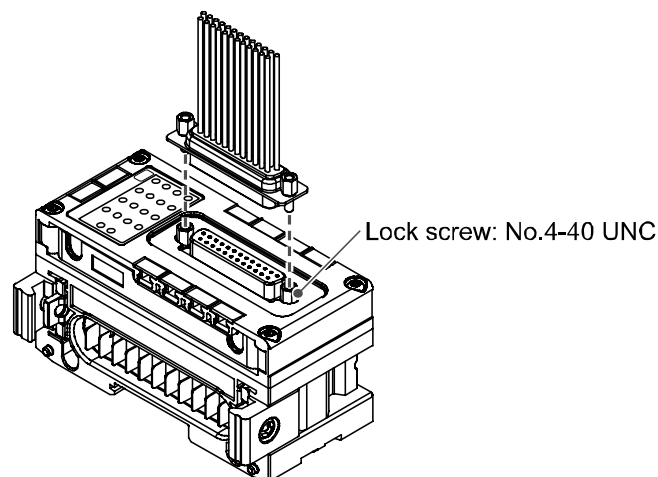

•Spring type terminal connection method is explained below.

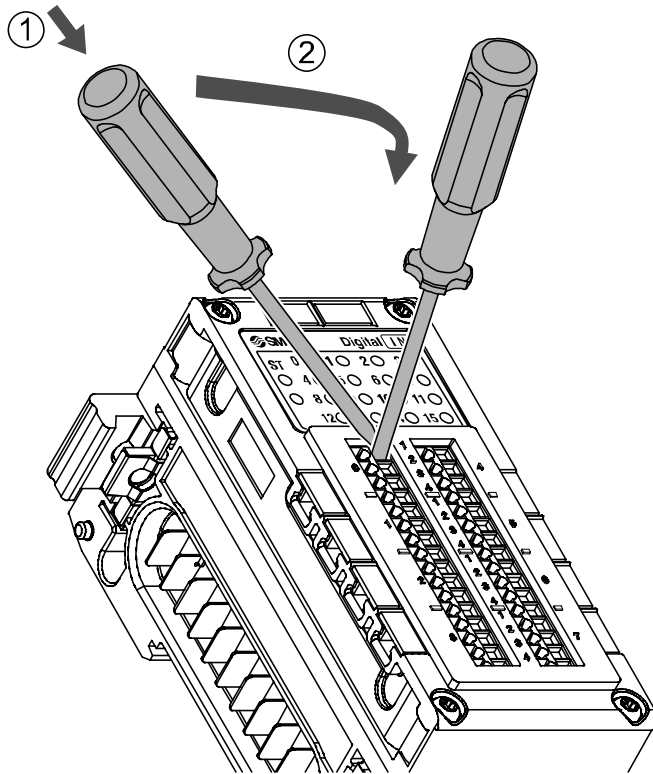

- ① Insert a flat blade screwdriver inclined to the left into the right hole of the two holes as shown in the figure below.

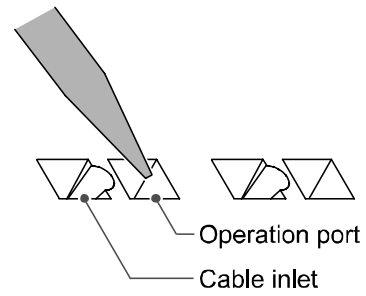

- ② Incline the screwdriver to the right as indicated by the arrow. When the screwdriver is pushed downwards until it stops, the cable inlet will open.

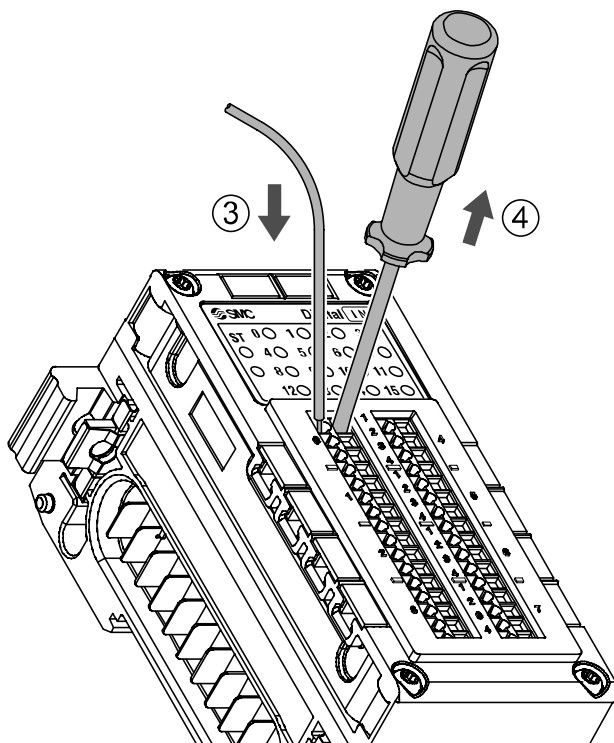
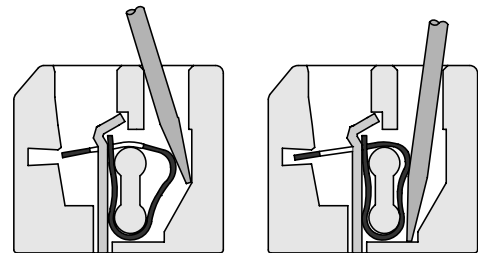

- ③ Insert the cable.

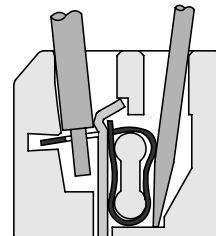

- ④ The spring will capture the cable when the flat blade screwdriver is pulled out. This completes the connection.

The electric wire below can be connected to the terminal block connector.

- Single conductor.
- Stranded conductor.
- Flexible stranded conductor (Stranded thin conductor).
- Flexible stranded conductor with the ultrasonic welded.
- Flexible stranded conductor with crimped ferrule.

●Precautions for handling

- To open the clamp, use a flat blade screwdriver of blade width 2.5 mm, and thickness of 0.4 mm or less.
- Applicable wire should have conduction area of 0.08 to 1.5 mm² (AWG16 to 28).
- The length of the electric wire to be stripped should be 5 to 6 mm.
If the stripped part is too long, it can cause insulation failure due to the exposure of the conductor.
If the stripped part is too short, it can cause contact failure due to the sheath being caught, or contact failure or power failure due to insufficient clamping of the conductor.

•Mounting the marker

Signal name of the input or output devices and unit address can be written to the marker, and it can be installed to each unit.

Mount the marker (EX600-ZT1) into the marker groove as required.

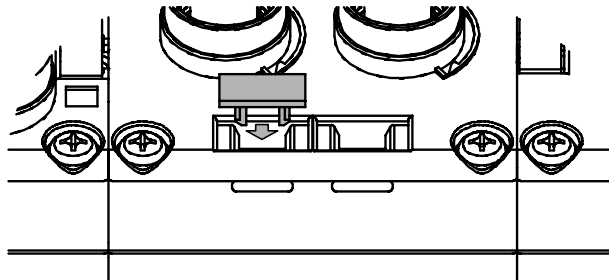

Digital input unit

Model Indication and How to Order

EX600-DX□□

Digital input

Connector, number of inputs and open circuit detection

Input type

Symbol	Content
P	PNP
N	NPN

Symbol	Connector	Number of inputs	Open circuit detection
B	4xM12 connector (5 pin) *	8 inputs	No
C	8xM8 connector (3 pin)	8 inputs	No
C1	8xM8 connector (3 pin)	8 inputs	Yes
D	8xM12 connector (5 pin) *	16 inputs	No
E	D-sub connector (25 pin)	16 inputs	No
F	Spring type terminals (32 pin)	16 inputs	No

*: An M12 connector (4 pin) can also be connected.

Names and Functions of Product

•EX600-DX□B

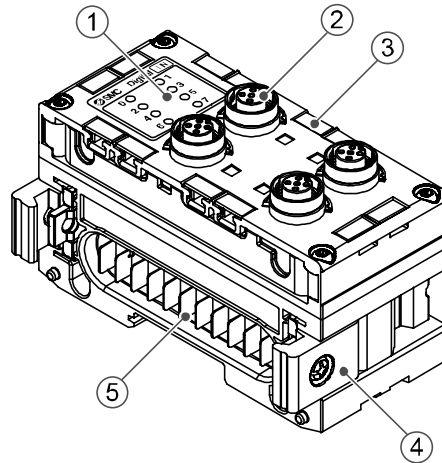

No.	Description	Function
1	Status display LED	Displays the status of the unit.
2	Connector (Input)	Connector for input device.
3	Marker groove	Groove to mount a marker.
4	Joint bracket	Bracket for joining to adjacent units.
5	Unit connector (Plug)	Transmits signals and power supplies to adjacent units.

•EX600-DX□□□

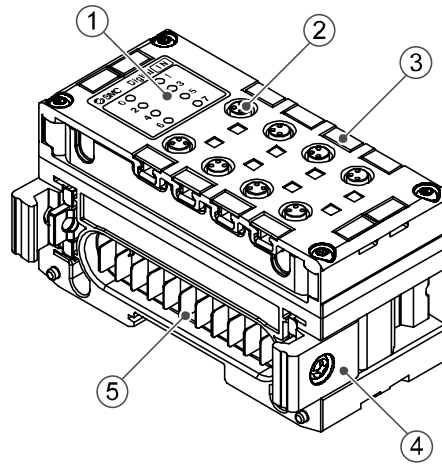

No.	Description	Function
1	Status display LED	Displays the status of the unit.
2	Connector (Input)	Connector for input device.
3	Marker groove	Groove to mount a marker.
4	Joint bracket	Bracket for joining to adjacent units.
5	Unit connector (Plug)	Transmits signals and power supplies to adjacent units.

•EX600-DX□□□

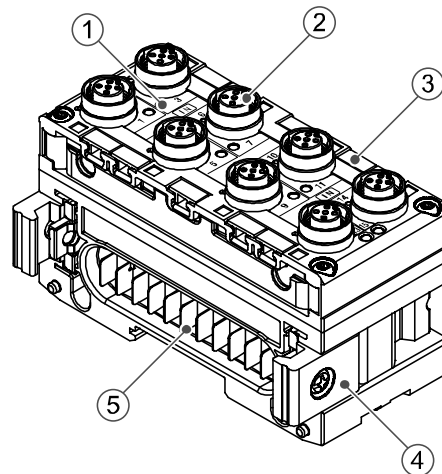

No.	Description	Function
1	Status display LED	Displays the status of the unit.
2	Connector (Input)	Connector for input device.
3	Marker groove	Groove to mount a marker.
4	Joint bracket	Bracket for joining to adjacent units.
5	Unit connector (Plug)	Transmits signals and power supplies to adjacent units.

•EX600-DX□E

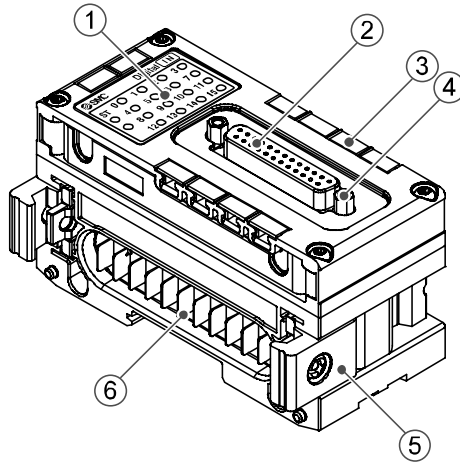

No.	Description	Function
1	Status display LED	Displays the status of the unit.
2	Connector (Input)	Connector for input device.
3	Marker groove	Groove to mount a marker.
4	Lock screw	Fixes D-sub connector. (No.4-40 UNC)
5	Joint bracket	Bracket for joining to adjacent units.
6	Unit connector (Plug)	Transmits signals and power supplies to adjacent units.

•EX600-DX□F

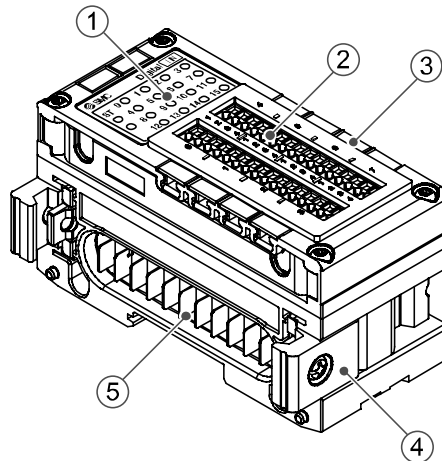

No.	Description	Function
1	Status display LED	Displays the status of the unit.
2	Connector (Input)	Connector for input device.
3	Marker groove	Groove to mount a marker.
4	Joint bracket	Bracket for joining to adjacent units.
5	Unit connector (Plug)	Transmits signals and power supplies to adjacent units.

Mounting and Installation

■Wiring

○Connector pin assignment and circuit diagram

(1)EX600-DX□B/EX600-DX□D

•Connector pin assignment

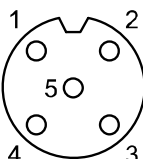
Configuration	Pin number	Signal name
	1	24 V (Control and input)
	2	Input 2
	3	0 V (Control and input)
	4	Input 1
	5	FE

*: An M12 connector (4 pin) can also be connected.

•Circuit diagram

•EX600-DXPB/EX600-DXPD

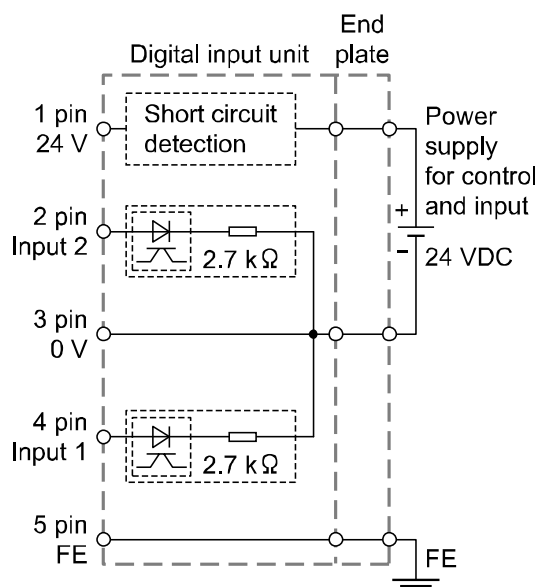

•EX600-DXNB/EX600-DXND

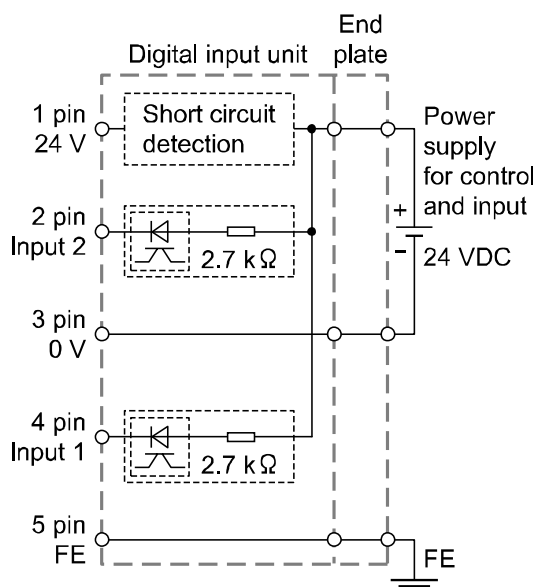

•Precautions for handling

Be sure to fit a seal cap on any unused connectors. Proper use of the seal cap enables the enclosure to achieve IP67 specification.

(2)EX600-DX□C□

•Connector pin assignment

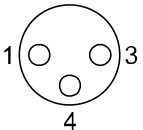
Configuration	Pin number	Signal name
	1	24 V (Control and input)
	3	0 V (Control and input)
	4	Input

•Circuit diagram

•EX600-DXPC□

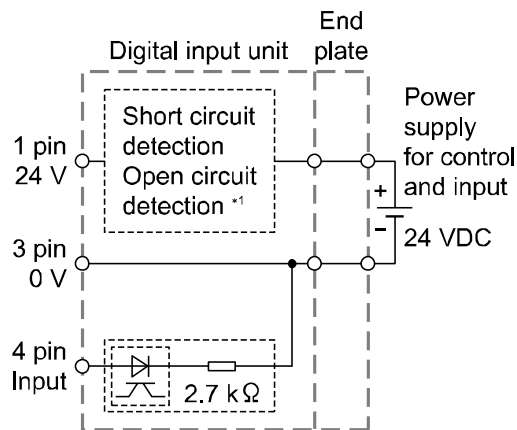

*1: Only for EX600-DXPC1.

•EX600-DXNC□

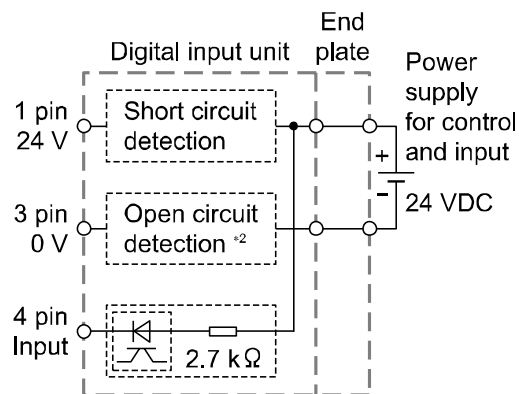

*2: Only for EX600-DXNC1.

•Precautions for handling

Be sure to fit a seal cap on any unused connectors. Proper use of the seal cap enables the enclosure to achieve IP67 specification.

Note the following points when using the open circuit detection:

- The 2 wire type input device cannot be correctly detected if its leakage current is 0.5 mA or less while the equipment is in the OFF state (solid state sensor, etc.) Ensure that all input device used has a leakage current above 0.5 mA in the OFF state.
- The 3 wire type input device cannot be correctly detected if its current consumption is 0.5 mA or less.
- The open circuit of input signals cannot be detected.
- Refer to the SI unit Operation Manual of protocol used for setting of the open circuit detection.

(3)EX600-DX□E

•Connector pin assignment

Configuration	Pin number	Signal name
	1	Input 0
	2	Input 2
	3	Input 4
	4	Input 6
	5	Input 8
	6	Input 10
	7	Input 12
	8	Input 14
	9	NC
	10	24 V (Control and input)
	11	0 V (Control and input)
	12	0 V (Control and input)
	13	FE
	14	Input 1
	15	Input 3
	16	Input 5
	17	Input 7
	18	Input 9
	19	Input 11
	20	Input 13
	21	Input 15
	22	24 V (Control and input)
	23	24 V (Control and input)
	24	0 V (Control and input)
	25	FE

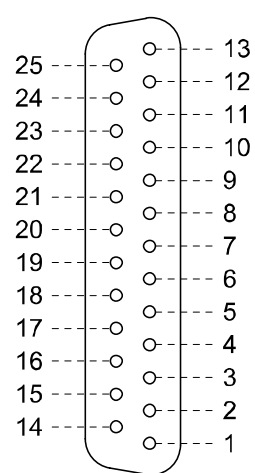

•Circuit diagram

•EX600-DXPE

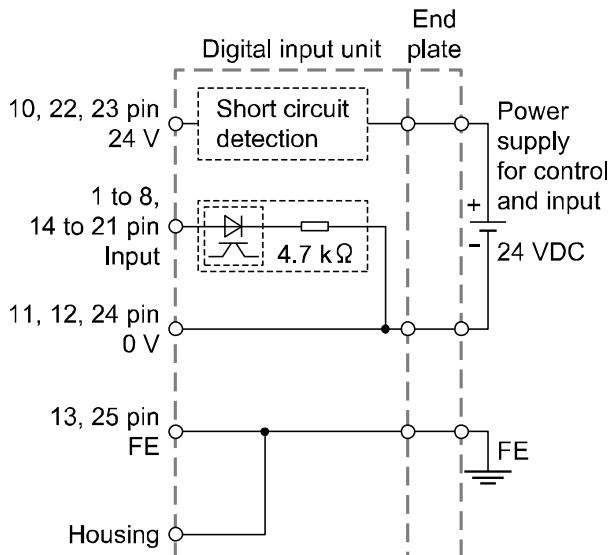

•EX600-DXNE

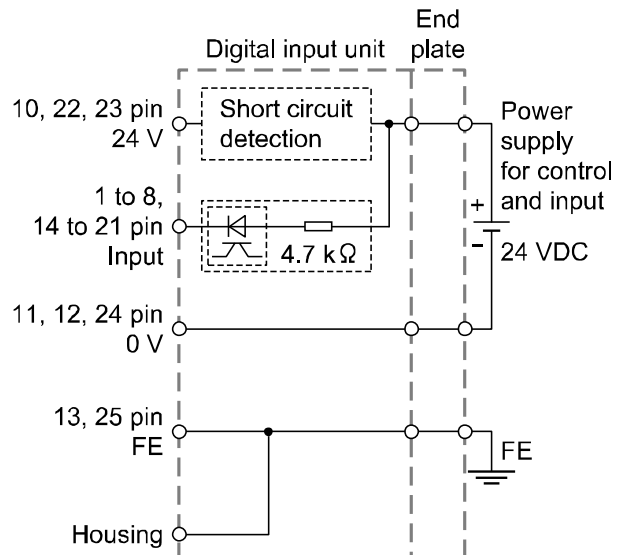

(4)EX600-DX□F

•Connector pin assignment

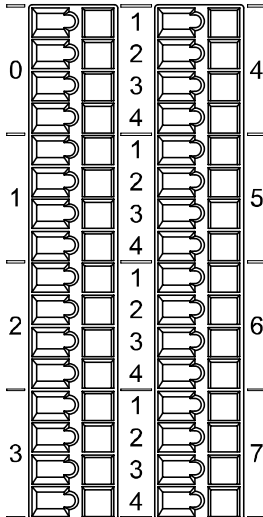
Configuration	Group	Pin number	Signal name	
	0	1	24 V (Control and input) X0	
		2	Input 0	
		3	Input 1	
		4	0 V (Control and input) X0	
	1	1	1	24 V (Control and input) X1
			2	Input 2
			3	Input 3
			4	0 V (Control and input) X1
	2	2	1	24 V (Control and input) X2
			2	Input 4
			3	Input 5
			4	0 V (Control and input) X2
	3	3	1	24 V (Control and input) X3
			2	Input 6
			3	Input 7
			4	0 V (Control and input) X3
	4	4	1	24 V (Control and input) X4
			2	Input 8
			3	Input 9
			4	0 V (Control and input) X4
	5	5	1	24 V (Control and input) X5
			2	Input 10
			3	Input 11
			4	0 V (Control and input) X5
	6	6	1	24 V (Control and input) X6
			2	Input 12
			3	Input 13
			4	0 V (Control and input) X6
7	7	1	24 V (Control and input) X7	
		2	Input 14	
		3	Input 15	
		4	0 V (Control and input) X7	

- Circuit diagram
- EX600-DXPF

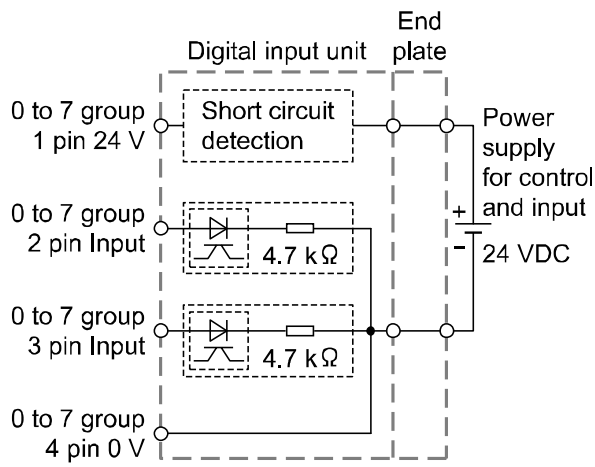

- EX600-DXNF

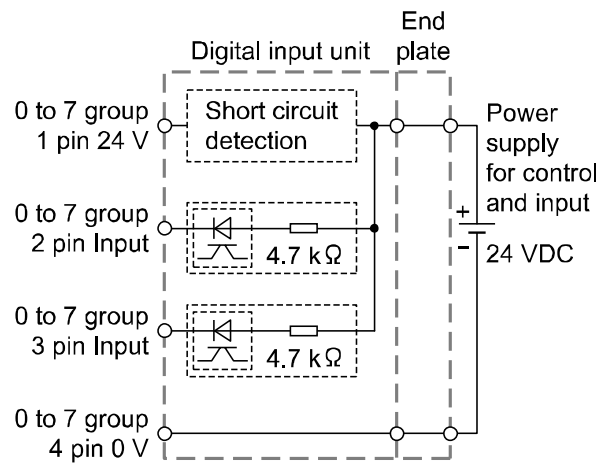



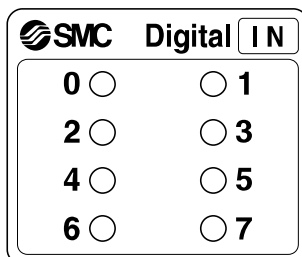

LED Display

The status display LED shows the following unit state.
Various kinds of status can be checked as follows:

- EX600-DX□B/EX600-DX□C□





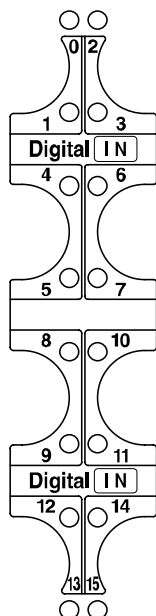

Display	Content
 OFF	The power supply for control and input, or the input device, is OFF.
 Green LED is ON	The input device is ON.
 Red LEDs are ON	<EX600-DX□C1> The power supply of input device has a short circuit. <Models other than EX600-DX□C1> The power supply of either input device of adjoined LED has a short circuit.
 Red LED is flashing	Either of the following conditions: •The input device ON/OFF count has exceeded the set value. •The input device is open circuit. (Only for EX600-DX□C1).

*: Refer to troubleshooting (SI unit Operation Manual of protocol used) for the further details of countermeasures.

•EX600-DX□□

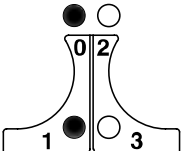

Display	Content
 OFF	The power supply for control and input, or the input device, is OFF.
 Green LED is ON	The input device is ON.
 Red LEDs are ON	The power supply of either input device of adjoined up and down LED has a short circuit.
 Red LED is flashing	The input device ON/OFF count has exceeded the set value.

*: Refer to troubleshooting (SI unit Operation Manual of protocol used) for the further details of countermeasures.

•EX600-DX□E/EX600-DX□F

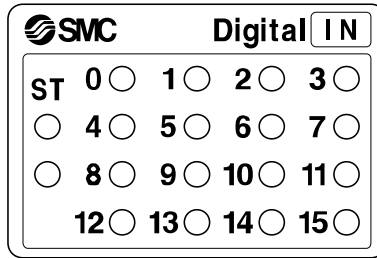

Display	Content
<p>ST ○ ST LED is OFF</p>	The power supply for control and input is OFF.
<p>ST ● Green LED is ON</p>	The product is operating normally.
<p>ST ● Red LED is ON</p>	The power supply of input device has a short circuit. (Each of input 0 to 15)
<p>ST ● Red LED is flashing</p>	The input device ON/OFF count has exceeded the set value. (Each of input 0 to 15)
<p>0 ○ 1 ○ 2 ○ 3 ○ 4 ○ 5 ○ 6 ○ 7 ○ 8 ○ 9 ○ 10 ○ 11 ○ 12 ○ 13 ○ 14 ○ 15 ○ "0 to 15" LEDs are OFF</p>	The input device is OFF. (Each LED display number corresponds to input 0 to 15.)
<p>0 ● 1 ● 2 ● 3 ● 4 ● 5 ● 6 ● 7 ● 8 ● 9 ● 10 ● 11 ● 12 ● 13 ● 14 ● 15 ● "0 to 15" green LEDs are ON</p>	The input device is ON. (Each LED display number corresponds to input 0 to 15.)

*: Refer to troubleshooting (SI unit Operation Manual of protocol used) for the further details of countermeasures.

Specification

Specifications

Model		EX600-DXPB	EX600-DXNB	EX600-DXPC□	EX600-DXNC□	EX600-DXPD	EX600-DXND	
Input specifications	Input type	PNP	NPN	PNP	NPN	PNP	NPN	
	Input connector	M12 (5 pin) socket *1		M8 (3 pin) socket		M12 (5 pin) socket *1		
	Number of inputs	8 inputs (2 inputs/connector)		8 inputs (1 input/connector)		16 inputs (2 inputs/connector)		
	Power supply voltage (Control and input)	24 VDC Class2, 2 A						
	Max. sensor supply current	0.5 A/ connector 2 A/unit		0.25 A/ connector 2 A/unit		0.5 A/ connector 2 A/unit		
	Protective function	Short circuit protection						
	Input resistance	2.7 kΩ						
	Rated input current	9 mA or less						
	ON voltage /ON current	17 V or more/5 mA or more (NPN input: between input terminal and +24 V) (PNP input: between input terminal and 0 V)						
	OFF voltage /OFF current	5 V or less/1 mA or less (NPN input: between input terminal and +24 V) (PNP input: between input terminal and 0 V)						
	Open circuit detection current	2-wire	-		0.5 mA/input *2		-	
		3-wire	-		0.5 mA/Connector *2		-	
Current consumption		50 mA or less		55 mA or less		70 mA or less		
Environment	Enclosure	IP67 (With manifold assembled) *3						
	Operating temperature range	-10 to 50 °C *4						
	Storage temperature range	-20 to 60 °C						
	Operating humidity range	35 to 85%RH (No condensation)						
	Withstand voltage	500 VAC for 1 minute between external terminals and FE						
	Insulation resistance	500 VDC, 10 MΩ or more between external terminals and FE						
	Pollution degree	Pollution degree 3 (UL508)						
Standard		CE marking, UL(CSA), RoHS						
Weight		300 g		275 g		340 g		

*1: An M12 connector (4 pin) can also be connected.

*2: Available only for EX600-DX□C1.

*3: All unused connectors must have a seal cap fitted.

*4: The UL compliant temperature is 0 to 50 °C.

Model		EX600-DXPE	EX600-DXNE	EX600-DXPF	EX600-DXNF
Input specifications	Input type	PNP	NPN	PNP	NPN
	Input connector	D-sub (25 pin) socket Lock screw: No.4-40 UNC		Spring type terminal (32 pin)	
	Number of inputs	16 inputs			
	Power supply voltage (Control and input)	24 VDC Class2, 2 A			
	Max. sensor supply current	2 A/unit		0.5 A/group 2 A/unit	
	Protective function	Short circuit protection			
	Input resistance	4.7 kΩ			
	Rated input current	5 mA or less			
	ON voltage /ON current	17 V or more/3 mA or more (NPN input: between input terminal and +24 V) (PNP input: between input terminal and 0 V)			
	OFF voltage /OFF current	5 V or less/1 mA or less (NPN input: between input terminal and +24 V) (PNP input: between input terminal and 0 V)			
Applicable wire	-		0.08 to 1.5 mm ² (AWG 16 to 28)		
Current consumption	50 mA or less		55 mA or less		
Environment	Enclosure	IP40 (With manifold assembled)			
	Operating temperature range	-10 to 50 °C (Max. surrounding air temperature rating: 50 °C) *1			
	Storage temperature range	-20 to 60 °C			
	Operating humidity range	35 to 85%RH (No condensation)			
	Withstand voltage	500 VAC for 1 minute between external terminals and FE			
	Insulation resistance	500 VDC, 10 MΩ or more between external terminals and FE			
	Pollution degree	For use in Pollution Degree 3 Environment (UL508)			
Standard	CE marking, UL (CSA), RoHS				
Weight	300 g		300 g		

*1: The UL compliant temperature is 0 to 50 °C.

○Digital input data

The relationship between the connector position and the input data assignment is as shown in the table below.

•Input signal assignment (EX600-DX□B)

Connector number		0	1	2	3
Connector position					
Input signal	Pin 2	Bit 1	Bit 3	Bit 5	Bit 7
	Pin 4	Bit 0	Bit 2	Bit 4	Bit 6

•Input signal assignment (EX600-DX□C□)

Connector number		0	1	2	3	4	5	6	7
Connector position									
Input signal	Pin 4	Bit 0	Bit 1	Bit 2	Bit 3	Bit 4	Bit 5	Bit 6	Bit 7

•Input signal assignment (EX600-DX□D)

Connector number		0	1	2	3	4	5	6	7
Connector position									
Input signal	Pin 2	Bit 1	Bit 3	Bit 5	Bit 7	Bit 9	Bit 11	Bit 13	Bit 15
	Pin 4	Bit 0	Bit 2	Bit 4	Bit 6	Bit 8	Bit 10	Bit 12	Bit 14

•Input signal assignment (EX600-DX□E)

Configuration	Pin number	1	2	3	4	5	6	7	8
	Signal name	Input 0	Input 2	Input 4	Input 6	Input 8	Input 10	Input 12	Input 14
	Input signal	Bit 0	Bit 2	Bit 4	Bit 6	Bit 8	Bit 10	Bit 12	Bit 14
	Pin number	14	15	16	17	18	19	20	21
	Signal name	Input 1	Input 3	Input 5	Input 7	Input 9	Input 11	Input 13	Input 15
	Input signal	Bit 1	Bit 3	Bit 5	Bit 7	Bit 9	Bit 11	Bit 13	Bit 15

•Input signal assignment (EX600-DX□F)

Group		0	1	2	3	4	5	6	7
Terminal position									
Input signal	Pin 2	Bit 0	Bit 2	Bit 4	Bit 6	Bit 8	Bit 10	Bit 12	Bit 14
	Pin 3	Bit 1	Bit 3	Bit 5	Bit 7	Bit 9	Bit 11	Bit 13	Bit 15

■Dimensions

•EX600-DX□B

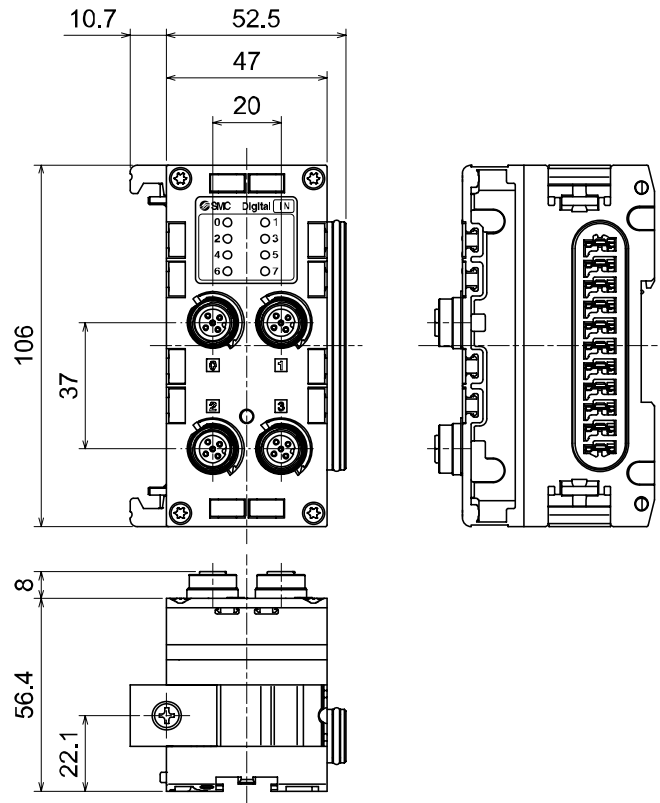

•EX600-DX□□□

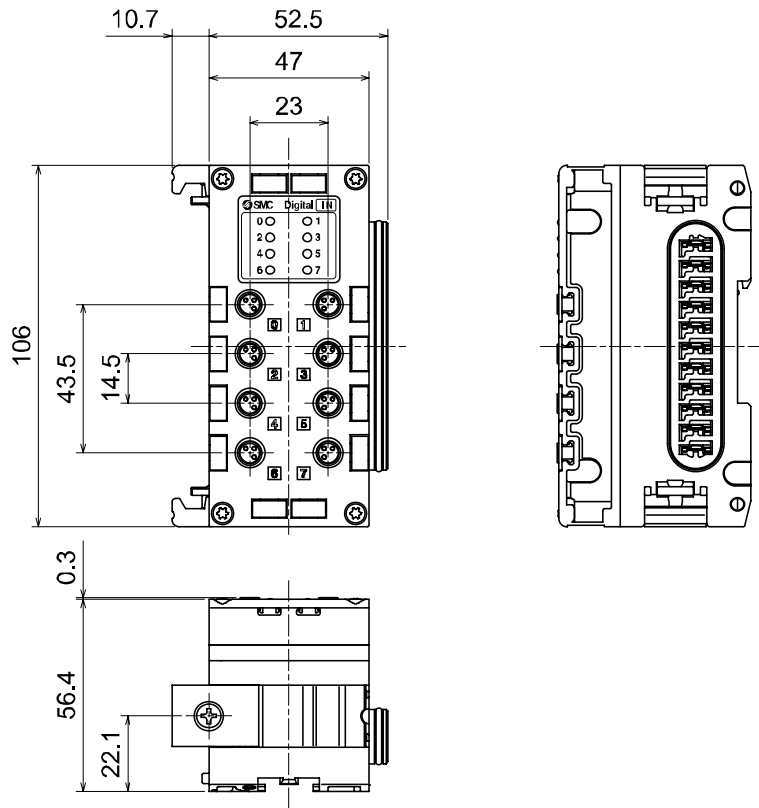

•EX600-DX□□D

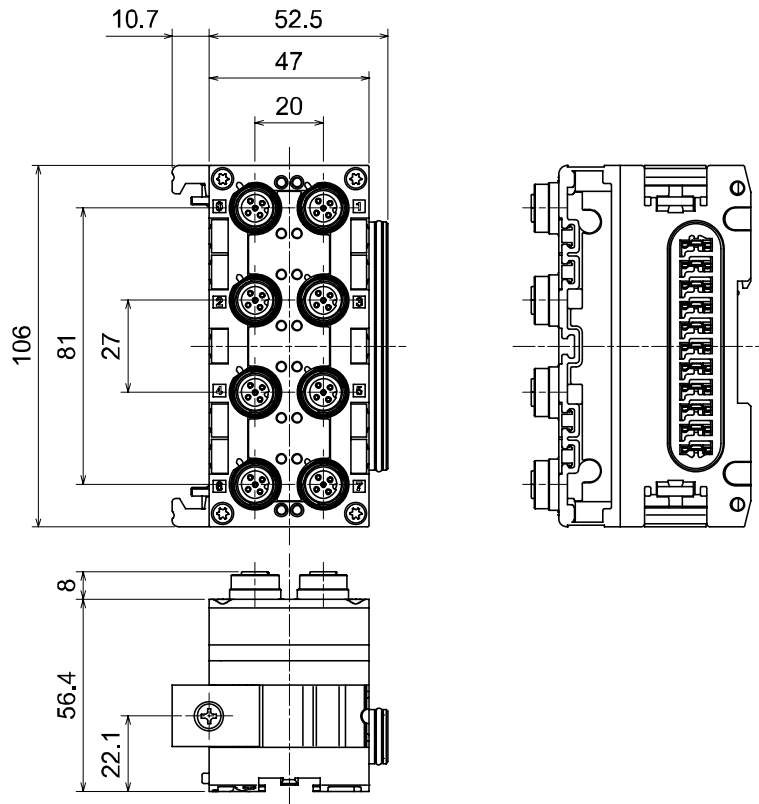

•EX600-DX□E

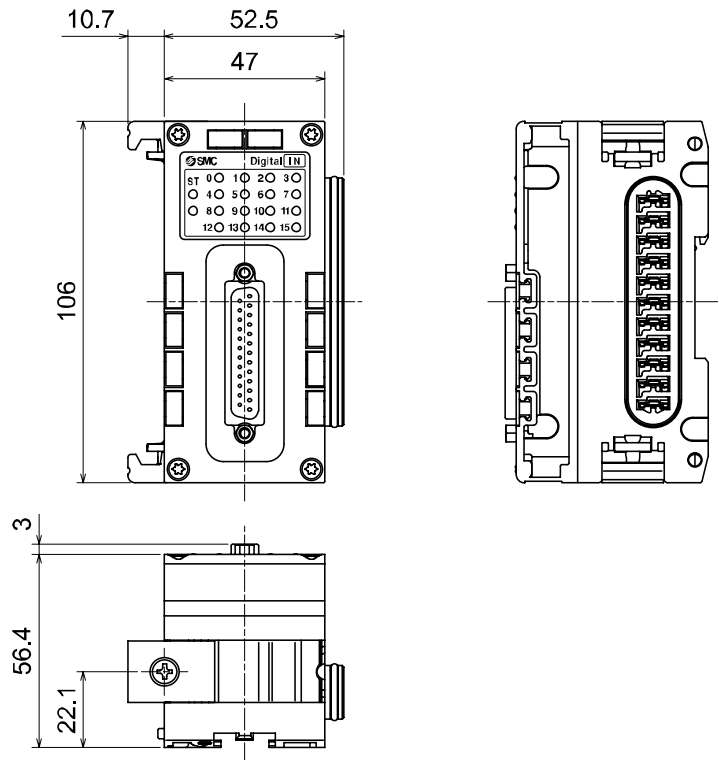

•EX600-DX□F

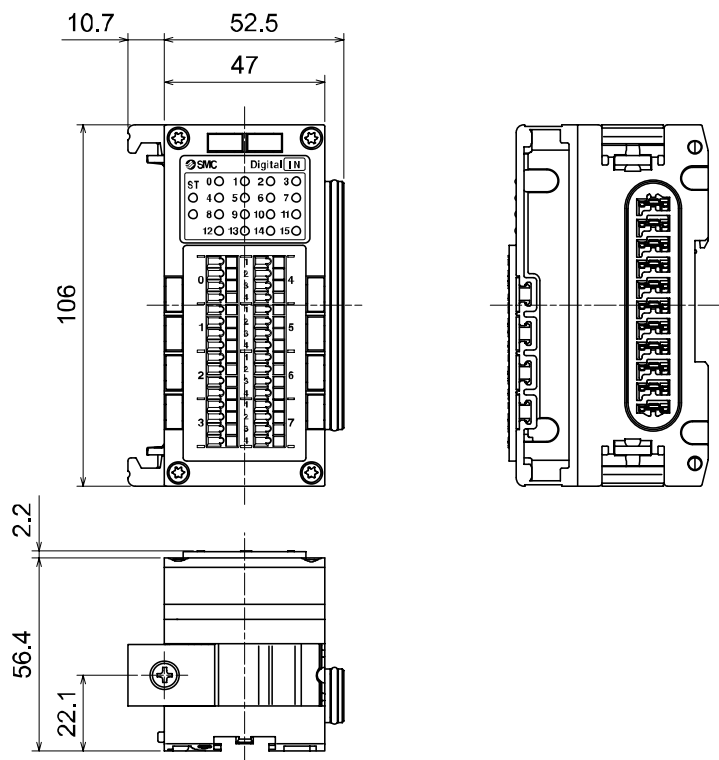

Digital output unit

Model Indication and How to Order

EX600-DY□□

Digital output

Connector and number of outputs

Output type

Symbol	Content
P	PNP
N	NPN

Symbol	Connector	Number of outputs
B	4xM12 connector (5 pin) *	8 outputs
E	D-sub connector (25 pin)	16 outputs
F	Spring type terminals (32 pin)	16 outputs

*: An M12 connector (4 pin) can also be connected.

Names and Functions of Product

•EX600-DY□B

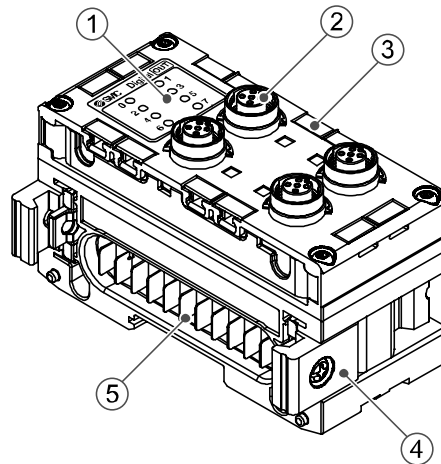

No.	Description	Function
1	Status display LED	Displays the status of the unit.
2	Connector (Output)	Connector for output device.
3	Marker groove	Groove to mount a marker.
4	Joint bracket	Bracket for joining to adjacent units.
5	Unit connector (Plug)	Transmits signals and power supplies to adjacent units.

•EX600-DY□E

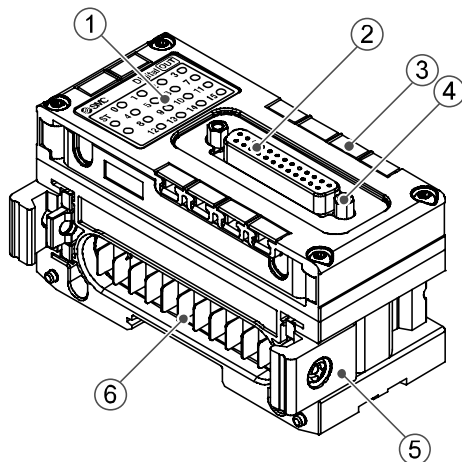

No.	Description	Function
1	Status display LED	Displays the status of the unit.
2	Connector (Output)	Connector for output device.
3	Marker groove	Groove to mount a marker.
4	Lock screw	Fixes D-sub connector. (No.4-40 UNC)
5	Joint bracket	Bracket for joining to adjacent units.
6	Unit connector (Plug)	Transmits signals and power supplies to adjacent units.

•EX600-DY□F

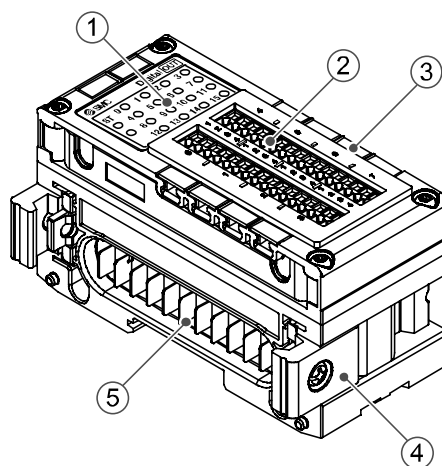

No.	Description	Function
1	Status display LED	Displays the status of the unit.
2	Connector (Output)	Connector for output device.
3	Marker groove	Groove to mount a marker.
4	Joint bracket	Bracket for joining to adjacent units.
5	Unit connector (Plug)	Transmits signals and power supplies to adjacent units.

Mounting and Installation

■Wiring

○Connector pin assignment and circuit diagram

(1)EX600-DY□B

•Connector pin assignment

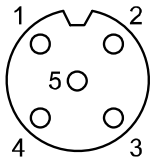
Configuration	Pin number	Signal name	
		EX600-DYPB	EX600-DYNB
	1	NC	24 V (Output)
	2	Output 2	Output 2
	3	0 V (Output)	NC
	4	Output 1	Output 1
	5	FE	FE

*: An M12 connector (4 pin) can also be connected.

•Circuit diagram

•EX600-DYPB

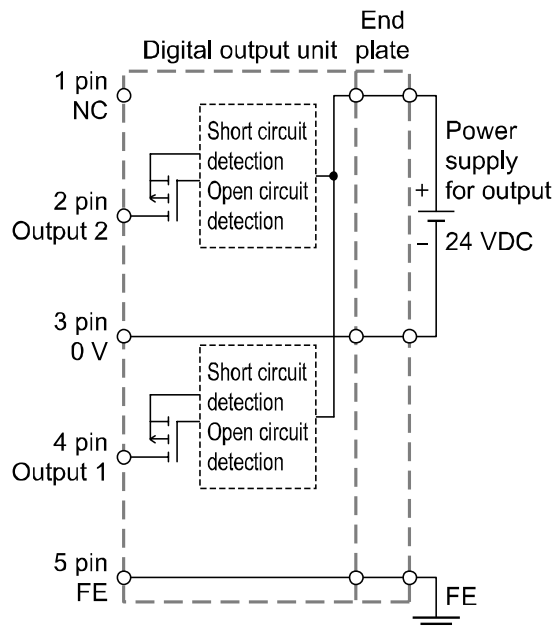

•EX600-DYNB

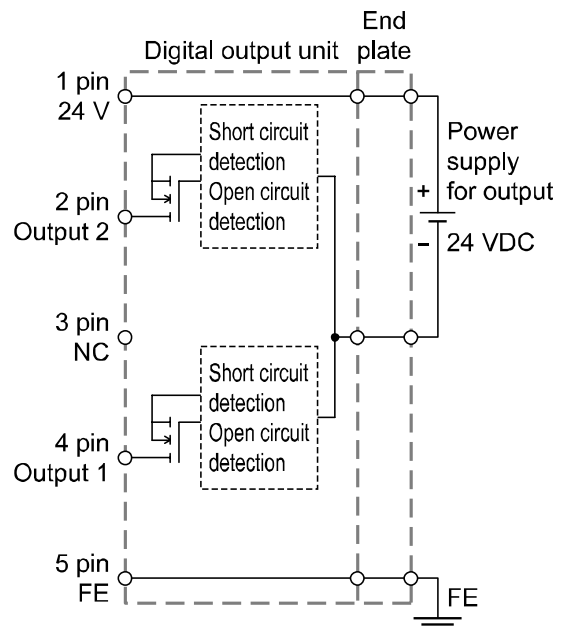

•Precautions for handling

Be sure to fit a seal cap on any unused connectors. Proper use of the seal cap enables the enclosure to achieve IP67 specification.

Note the following points when using the open circuit detection:

- This function detects open circuit only when the output is OFF. Therefore if output is turned ON, open circuit can not be detected.
- Refer to the SI unit Operation Manual of protocol used for setting of the open circuit detection.

(2)EX600-DY□E

•Connector pin assignment

Configuration	Pin number	Signal name	
		EX600-DYPE	EX600-DYNE
	1	Output 0	
	2	Output 2	
	3	Output 4	
	4	Output 6	
	5	Output 8	
	6	Output 10	
	7	Output 12	
	8	Output 14	
	9	NC	
	10	NC	
	11	NC	
	12	NC	
	13	0 V (Output)	24 V (Output)
	14	Output 1	
	15	Output 3	
	16	Output 5	
	17	Output 7	
	18	Output 9	
	19	Output 11	
	20	Output 13	
	21	Output 15	
	22	NC	
	23	NC	
	24	NC	
	25	0 V (Output)	24 V (Output)

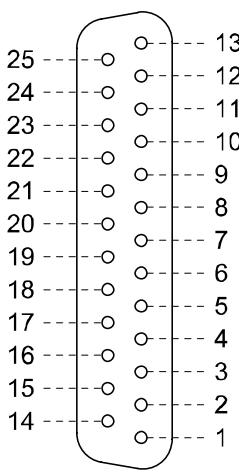

•Circuit diagram

•EX600-DYPE

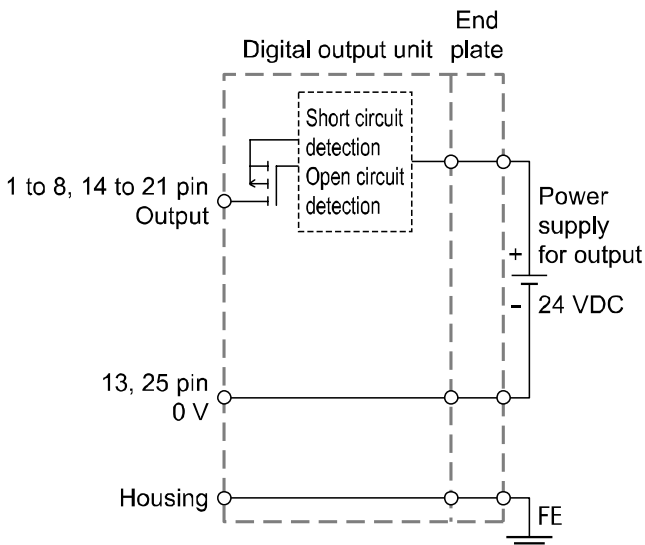

•EX600-DYNE

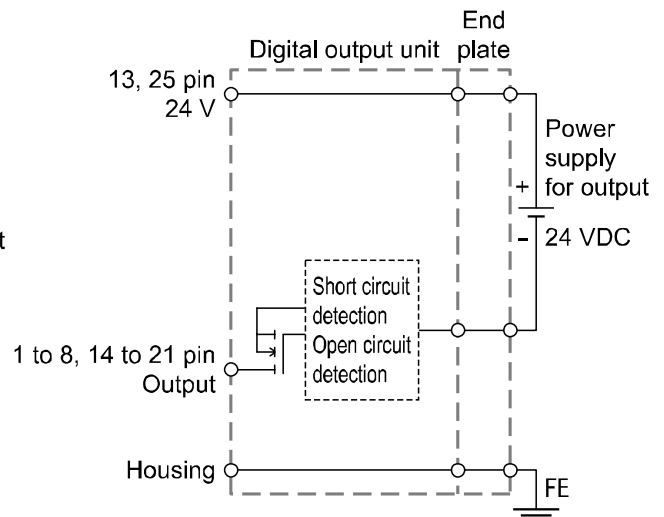

●Precautions for handling

Note the following points when using the open circuit detection:

- This function detects open circuit only when the output is OFF. Therefore if output is turned ON, open circuit can not be detected.
- Refer to the SI unit Operation Manual of protocol used for setting of the open circuit detection.

(3)EX600-DY□F

•Connector pin assignment

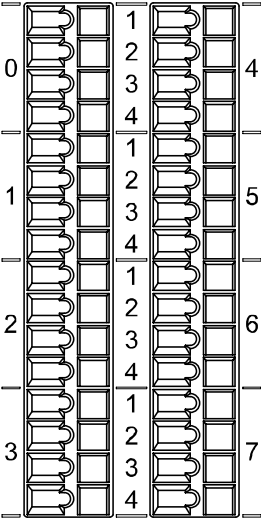
Configuration	Group	Number	Signal name		
			EX600-DYPF	EX600-DYNF	
	0	1	0 V (Output)	24 V (Output)	
		2	Output 0		
		3	0 V (Output)	24 V (Output)	
		4	Output 1		
	1	1	1	0 V (Output)	24 V (Output)
			2	Output 2	
			3	0 V (Output)	24 V (Output)
			4	Output 3	
	2	2	1	0 V (Output)	24 V (Output)
			2	Output 4	
			3	0 V (Output)	24 V (Output)
			4	Output 5	
	3	3	1	0 V (Output)	24 V (Output)
			2	Output 6	
			3	0 V (Output)	24 V (Output)
			4	Output 7	
	4	4	1	0 V (Output)	24 V (Output)
			2	Output 8	
			3	0 V (Output)	24 V (Output)
			4	Output 9	
	5	5	1	0 V (Output)	24 V (Output)
			2	Output 10	
			3	0 V (Output)	24 V (Output)
			4	Output 11	
	6	6	1	0 V (Output)	24 V (Output)
			2	Output 12	
			3	0 V (Output)	24 V (Output)
			4	Output 13	
7	7	1	0 V (Output)	24 V (Output)	
		2	Output 14		
		3	0 V (Output)	24 V (Output)	
		4	Output 15		

- Circuit diagram
- EX600-DYPF

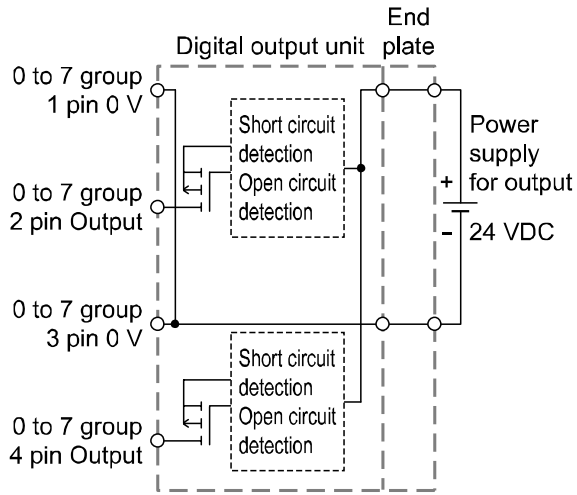

- EX600-DYNF

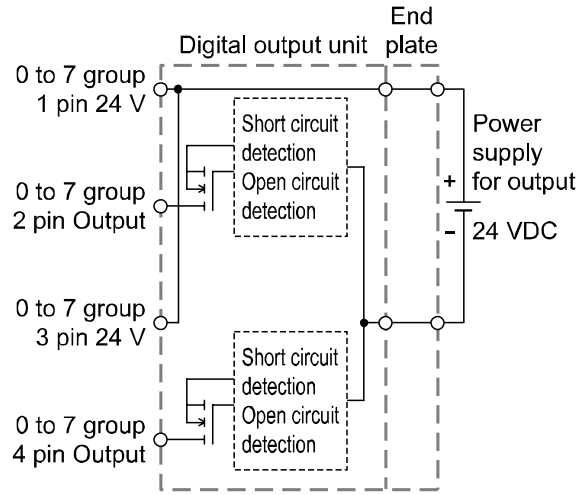

•Precautions for handling

Note the following points when using the open circuit detection:

- This function detects open circuit only when the output is OFF. Therefore if output is turned ON, open circuit can not be detected.
- Refer to the SI unit Operation Manual of protocol used for setting of the open circuit detection.

LED Display

The status display LED shows the following unit state.
Various kinds of status can be checked as follows:

•EX600-DY□B

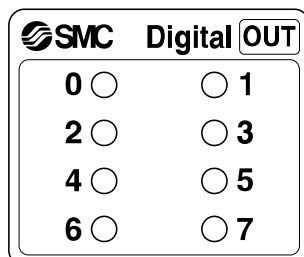

Display	Content
○ OFF	The power supply for control and input, or the output device, is OFF.
● Green LED is ON	The output device is ON.
● Red LED is ON	The output device has a short circuit.
⊙ Red LED is flashing	Either of the following conditions: •The output device ON/OFF count has exceeded the set value. •The output device is open circuit.

*: Refer to troubleshooting (SI unit Operation Manual of protocol used) for the further details of countermeasures.

•EX600-DY□E/EX600-DY□F

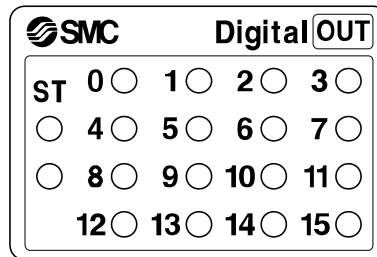

Display	Content
<p>ST ○ OFF</p>	The power supply for control and input is OFF.
<p>ST ● Green LED is ON</p>	The product is operating normally.
<p>ST ● Red LED is ON</p>	The output device has a short circuit. (Each of output 0 to 15)
<p>ST ● Red LED is flashing</p>	Either of the following conditions: <ul style="list-style-type: none"> •The output device ON/OFF count has exceeded the set value. (Each of output 0 to 15) •The output device is open circuit. (Each of output 0 to 15)
<p>0 ○ 1 ○ 2 ○ 3 ○ 4 ○ 5 ○ 6 ○ 7 ○ 8 ○ 9 ○ 10 ○ 11 ○ 12 ○ 13 ○ 14 ○ 15 ○ "0 to 15" LEDs are OFF</p>	The output device is OFF. (Each LED display number corresponds to output 0 to 15.)
<p>0 ● 1 ● 2 ● 3 ● 4 ● 5 ● 6 ● 7 ● 8 ● 9 ● 10 ● 11 ● 12 ● 13 ● 14 ● 15 ● "0 to 15" green LEDs are ON</p>	The output device is ON. (Each LED display number corresponds to output 0 to 15.)

*: Refer to troubleshooting (SI unit Operation Manual of protocol used) for the further details of countermeasures.

Specification

■ Specifications

Model	EX600-DYPB	EX600-DYNB	EX600-DYPE	EX600-DYNE	EX600-DYPF	EX600-DYNF	
Output specifications	Output type	PNP	NPN	PNP	NPN	PNP	NPN
	Output connector	M12 (5 pin) socket *1		D-sub (25 pin) socket Lock screw: No.4-40 UNC		Spring type terminal (32 pin)	
	Number of outputs	8 outputs (2 outputs/connector)		16 outputs			
	Power supply voltage (Control and input)	24 VDC Class2, 2 A					
	Power supply voltage (Output)	24 VDC Class2, 2 A					
	Max. load current	0.5 A/output 2 A/unit					
	Protective function	Short circuit protection					
Acceptable electric wire	-		-		0.08 to 1.5 mm ² (AWG 16 to 28)		
Current consumption	50 mA or less						
Environment	Enclosure	IP67 (With manifold assembled) *2		IP40 (With manifold assembled)			
	Operating temperature range	-10 to 50 °C (Max. surrounding air temperature rating: 50 °C) *3					
	Storage temperature range	-20 to 60 °C					
	Operating humidity range	35 to 85%RH (No condensation)					
	Withstand voltage	500 VAC for 1 minute between external terminals and FE					
	Insulation resistance	500 VDC, 10 MΩ or more between external terminals and FE					
	Pollution degree	For use in Pollution Degree 3 Environment (UL508)					
Standard	CE marking, UL (CSA), RoHS						
Weight	300 g		300 g		300 g		

*1: An M12 connector (4 pin) can also be connected.

*2: All unused connectors must have a seal cap fitted.

*3: The UL compliant temperature is 0 to 50 °C.

○ Digital Output data

The relationship between the connector position and the output data assignment is as shown in the table below.

• Output signal assignment (EX600-DY□B)

Connector number		0	1	2	3
Connector position					
Output signal	Pin 2	Bit 1	Bit 3	Bit 5	Bit 7
	Pin 4	Bit 0	Bit 2	Bit 4	Bit 6

• Output signal assignment (EX600-DY□E)

Configuration	Pin number	1	2	3	4	5	6	7	8
	Signal name	Output 0	Output 2	Output 4	Output 6	Output 8	Output 10	Output 12	Output 14
	Output signal	Bit 0	Bit 2	Bit 4	Bit 6	Bit 8	Bit 10	Bit 12	Bit 14
	Pin number	14	15	16	17	18	19	20	21
	Signal name	Output 1	Output 3	Output 5	Output 7	Output 9	Output 11	Output 13	Output 15
	Output signal	Bit 1	Bit 3	Bit 5	Bit 7	Bit 9	Bit 11	Bit 13	Bit 15

• Output signal assignment (EX600-DY□F)

Group	0	1	2	3	4	5	6	7	
Terminal position									
Output signal	Pin 2	Bit 0	Bit 2	Bit 4	Bit 6	Bit 8	Bit 10	Bit 12	Bit 14
	Pin 4	Bit 1	Bit 3	Bit 5	Bit 7	Bit 9	Bit 11	Bit 13	Bit 15

■ Dimensions

• EX600-DY□B

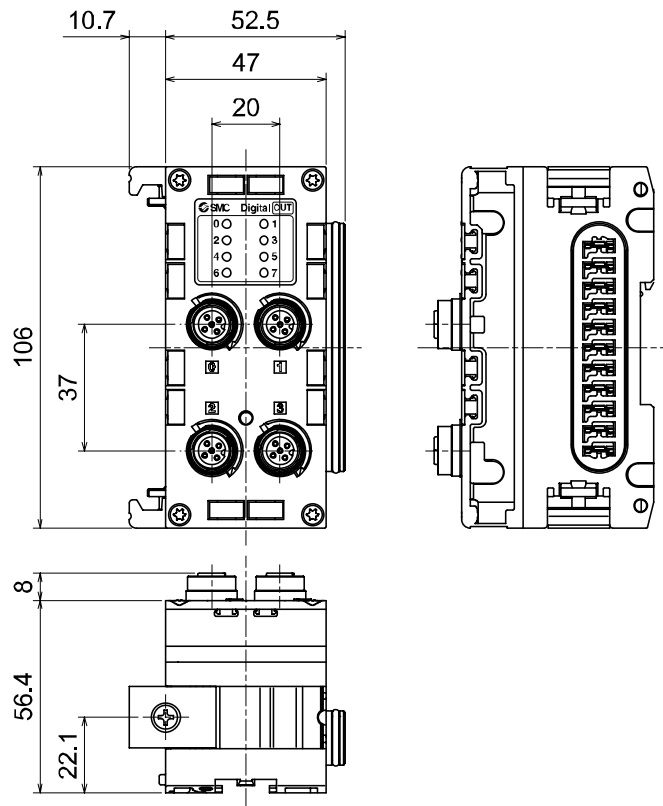

• EX600-DY□E

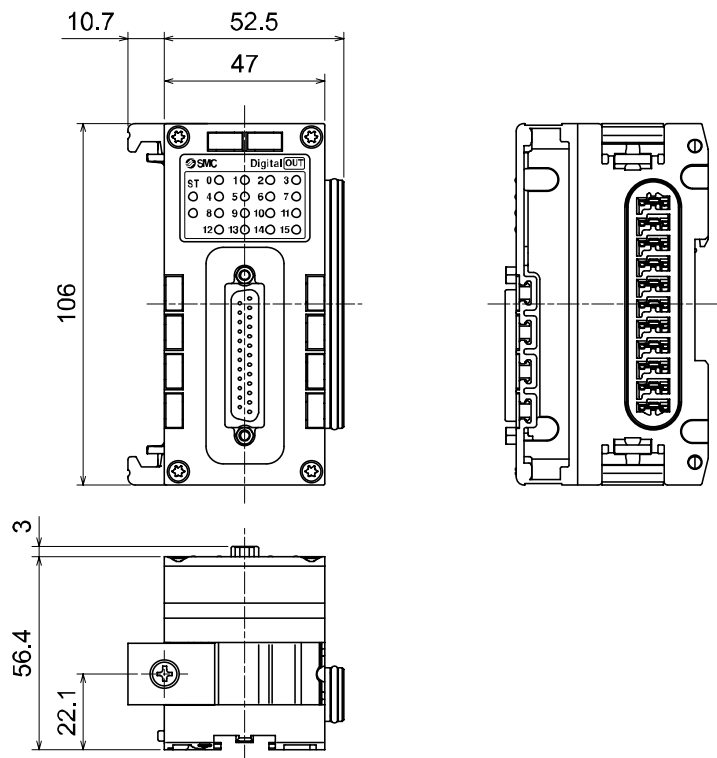

•EX600-DY□□

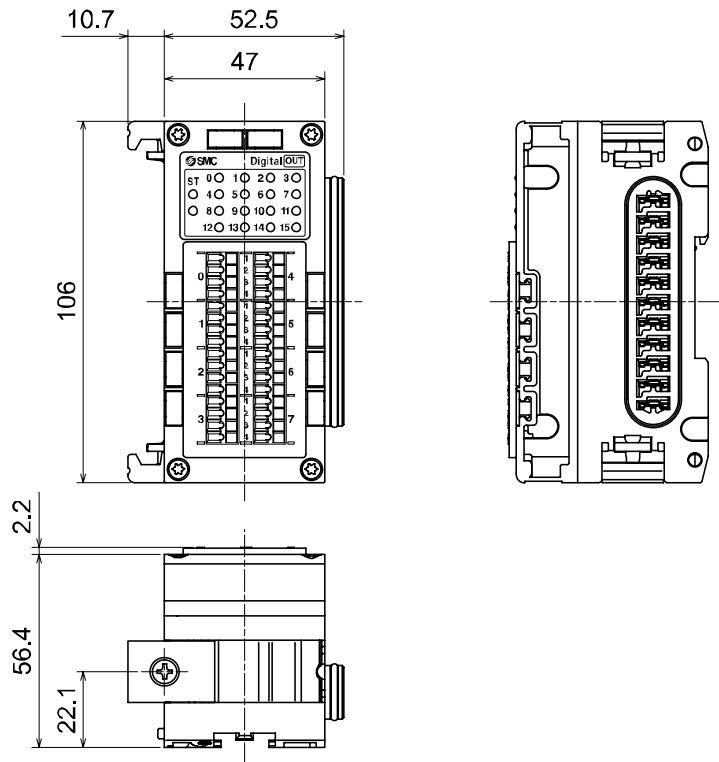

Digital I/O unit

Model Indication and How to Order

EX600-DM □ □

Digital I/O
Input and
Output type

Symbol	Content
P	PNP
N	NPN

Connector and number of I/O

Symbol	Connector	Number of inputs	Number of outputs
E	D-sub connector (25 pin)	8 inputs	8 outputs
F	Spring type terminals (32 pin)	8 inputs	8 outputs

Names and Functions of Product

•EX600-DM□□E

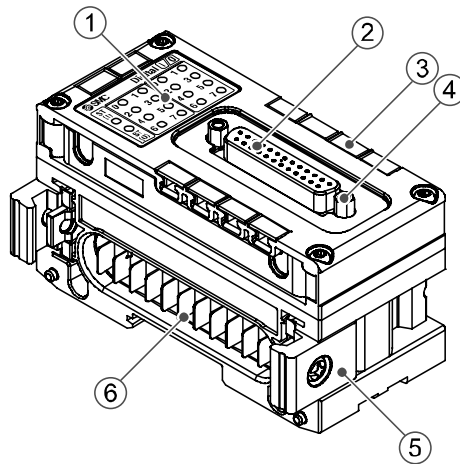

No.	Description	Function
1	Status display LED	Displays the status of the unit.
2	Connector (I/O)	Connector for input and output devices.
3	Marker groove	Groove to mount a marker.
4	Lock screw	Fixes D-sub connector. (No.4-40 UNC)
5	Joint bracket	Bracket for joining to adjacent units.
6	Unit connector (Plug)	Transmits signals and power supplies to adjacent units.

•EX600-DM□F

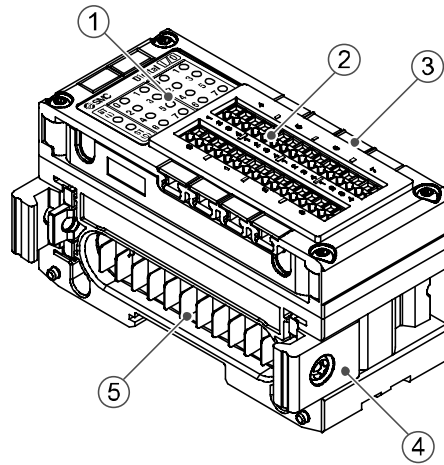

No.	Description	Function
1	Status display LED	Displays the status of the unit.
2	Connector (I/O)	Connector for input and output devices.
3	Marker groove	Groove to mount a marker.
4	Joint bracket	Bracket for joining to adjacent units.
5	Unit connector (Plug)	Transmits signals and power supplies to adjacent units.

Mounting and Installation

■Wiring

○Connector pin assignment and circuit diagram

(1)EX600-DM□E

•Connector pin assignment

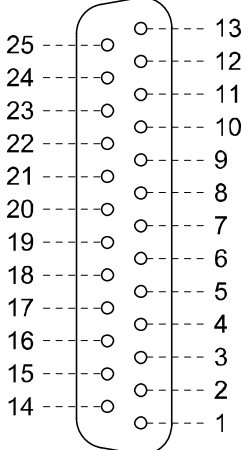
Configuration	Pin number	Signal name	
		EX600-DMPE	EX600-DMNE
	1	Input 0	
	2	Input 1	
	3	Input 2	
	4	Input 3	
	5	Input 4	
	6	Input 5	
	7	Input 6	
	8	Input 7	
	9	24 V (Control and input)	
	10	24 V (Control and input)	
	11	0 V (Control and input)	
	12	0 V (Control and input)	
	13	FE	
	14	Output 0	
	15	Output 1	
	16	Output 2	
	17	Output 3	
	18	Output 4	
	19	Output 5	
	20	Output 6	
	21	Output 7	
	22	0 V (Output)	24 V (Output)
	23	0 V (Output)	24 V (Output)
	24	0 V (Output)	24 V (Output)
	25	FE	

- Circuit diagram
- EX600-DMPE

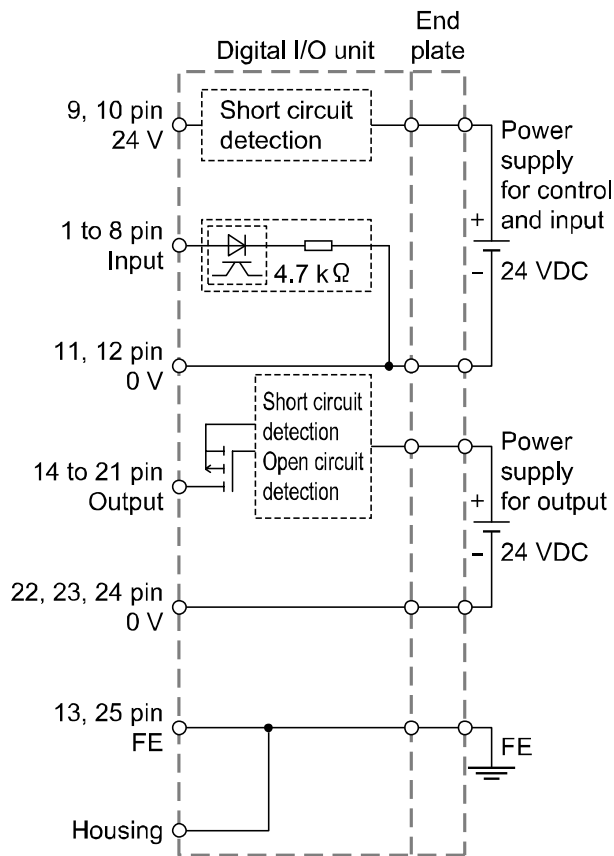

- EX600-DMNE

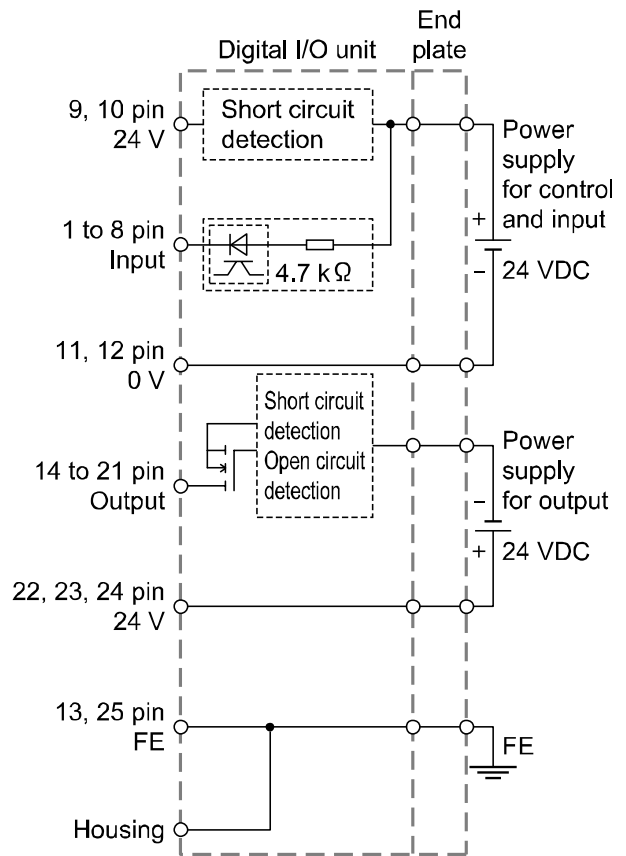

- Precautions for handling

Note the following points when using the open circuit detection:

- This function detects open circuit only when the output is OFF. Therefore if output is turned ON, open circuit can not be detected.
- Refer to the SI unit Operation Manual of protocol used for setting of the open circuit detection.

(2)EX600-DM□F

•Connector pin assignment

Configuration	Group	Number	Signal name	
			EX600-DMPF	EX600-DMNF
	0	1	24 V (Control and input) X0	
		2	Input 0	
		3	Input 1	
		4	0 V (Control and input) X0	
	1	1	24 V (Control and input) X1	
		2	Input 2	
		3	Input 3	
		4	0 V (Control and input) X1	
	2	1	24 V (Control and input) X2	
		2	Input 4	
		3	Input 5	
		4	0 V (Control and input) X2	
	3	1	24 V (Control and input) X3	
		2	Input 6	
		3	Input 7	
		4	0 V Control and input) X3	
	4	1	0 V (Output)	24 V (Output)
		2	Output 0	
		3	0 V (Output)	24 V (Output)
		4	Output 1	
	5	1	0 V (Output)	24 V (Output)
		2	Output 2	
		3	0 V (Output)	24 V (Output)
		4	Output 3	
	6	1	0 V (Output)	24 V (Output)
		2	Output 4	
		3	0 V (Output)	24 V (Output)
		4	Output 5	
7	1	0 V (Output)	24 V (Output)	
	2	Output 6		
	3	0 V (Output)	24 V (Output)	
	4	Output 7		

- Circuit diagram
- EX600-DMPF

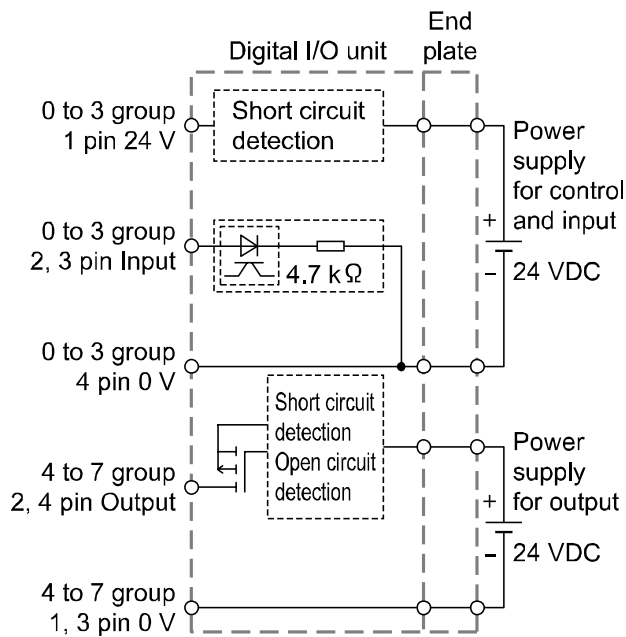

- EX600-DMNF

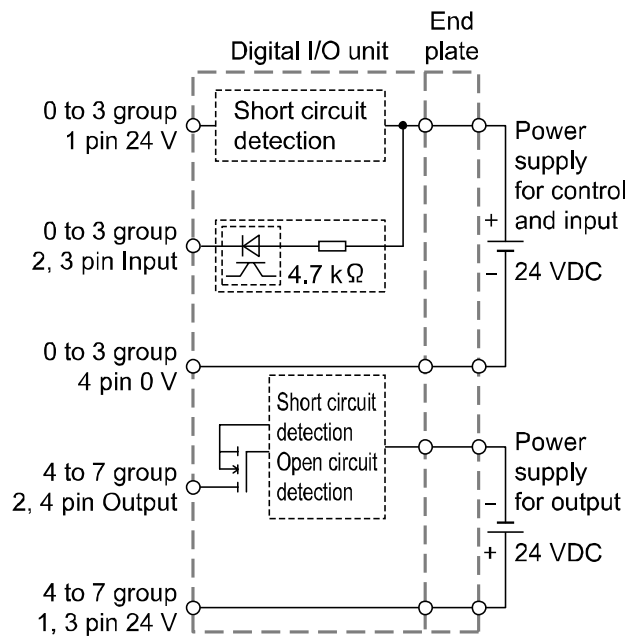

•Precautions for handling

Note the following points when using the open circuit detection:

- This function detects open circuit only when the output is OFF. Therefore if output is turned ON, open circuit can not be detected.
- Refer to the SI unit Operation Manual of protocol used for setting of the open circuit detection.

LED Display

The status display LED shows the following unit state.
Various kinds of status can be checked as follows.

•EX600-DM□E/EX600-DM□F

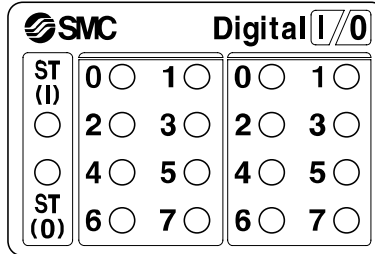

Display	Content
<p>ST (I) ○ ○ ST (O) OFF</p>	<p>The power supply for control and input is OFF.</p>
<p>ST (I) ● ● ST (O) Green LEDs are ON</p>	<p>The product is operating normally.</p>
<p>ST (I) ● Red ST(I) LED is ON</p>	<p>The power supply of input device has a short circuit. (Each of input 0 to 7)</p>
<p>● ST (O) Red ST(O) LED is ON</p>	<p>The output device has a short circuit. (Each of output 0 to 7)</p>
<p>ST (I) ● Red ST(I) LED is flashing</p>	<p>The input device ON/OFF count has exceeded the set value. (Each of input 0 to 7)</p>
<p>● ST (O) Red ST(O) LED is flashing</p>	<p>Either of the following conditions: •The output device ON/OFF count has exceeded the set value. (Each of output 0 to 7) •The output device is open circuit. (Each of output 0 to 7)</p>

*: Refer to troubleshooting (SI unit Operation Manual of protocol used) for the further details of countermeasures.

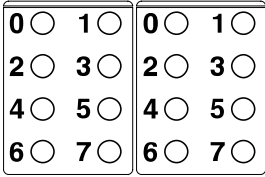
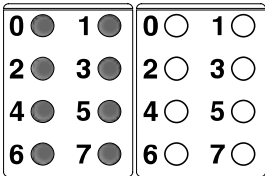
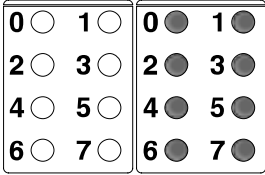
Display	Content
 <p style="text-align: center;">OFF</p>	<p>The input device and the output device are OFF. (Each LED display number corresponds to input 0 to 7 and output 0 to 7.)</p>
 <p>Input (left) "0 to 7" green LEDs are ON</p>	<p>The input device is ON. (Each LED display number corresponds to input 0 to 7.)</p>
 <p>Output (right) "0 to 7" green LEDs are ON</p>	<p>The output device is ON. (Each LED display number corresponds to output 0 to 7.)</p>

*: Refer to troubleshooting (SI unit Operation Manual of protocol used) for the further details of countermeasures.

Specification

■ Specifications

Model	EX600-DMPE	EX600-DMNE	EX600-DMPF	EX600-DMNF
Input and output type	PNP	NPN	PNP	NPN
Connector	D-sub (25 pin) socket Lock screw: No.4-40 UNC		Spring type terminal (32 pin)	
Input specifications	Number of inputs	8 inputs		
	Power supply voltage (Control and input)	24 VDC Class2, 2 A		
	Max. sensor supply current	2 A/unit	0.5 A/group 2 A/unit	
	Protective function	Short circuit protection		
	Input resistance	4.7 kΩ		
	Rated input current	5 mA or less		
	ON voltage /ON current	17 V or more/3 mA or more (NPN input: between input terminal and +24 V) (PNP input: between input terminal and 0 V)		
OFF voltage /OFF current	5 V or less/1 mA or less (NPN input: between input terminal and +24 V) (PNP input: between input terminal and 0 V)			
Output specifications	Number of outputs	8 outputs		
	Power supply voltage (Output)	24 VDC Class2, 2 A		
	Max. load current	0.5 A/output 2 A/unit		
	Protective function	Short circuit protection		
Acceptable electric wire	-		0.08 to 1.5 mm ² (AWG 16 to 28)	
Current consumption	50 mA or less		60 mA or less	
Environment	Enclosure	IP40 (With manifold assembled)		
	Operating temperature range	-10 to 50 °C (Max. surrounding air temperature rating: 50 °C) *1		
	Storage temperature range	-20 to 60 °C		
	Operating humidity range	35 to 85%RH (No condensation)		
	Withstand voltage	500 VAC for 1 minute between external terminals and FE		
	Insulation resistance	500 VDC, 10 MΩ or more between external terminals and FE		
	Pollution degree	For use in Pollution Degree 3 Environment (UL508)		
Standard	CE marking, UL (CSA), RoHS			
Weight	300 g		300 g	

*1: The UL compliant temperature is 0 to 50 °C.

○ Digital I/O data

The relationship between the connector position and the I/O data assignment is as shown in the table below.

• I/O signal assignment (EX600-DM□E)

Configuration	Pin number	1	2	3	4	5	6	7	8
	Signal name	Input 0	Input 1	Input 2	Input 3	Input 4	Input 5	Input 6	Input 7
	Input signal	Bit 0	Bit 1	Bit 2	Bit 3	Bit 4	Bit 5	Bit 6	Bit 7
	Pin number	14	15	16	17	18	19	20	21
	Signal name	Output 0	Output 1	Output 2	Output 3	Output 4	Output 5	Output 6	Output 7
	Output signal	Bit 0	Bit 1	Bit 2	Bit 3	Bit 4	Bit 5	Bit 6	Bit 7

• I/O signal assignment (EX600-DM□F)

Group		0	1	2	3	4	5	6	7
Terminal position									
Input signal	Pin2	Bit 0	Bit 2	Bit 4	Bit 6	-	-	-	-
	Pin3	Bit 1	Bit 3	Bit 5	Bit 7	-	-	-	-
Output signal	Pin2	-	-	-	-	Bit 0	Bit 2	Bit 4	Bit 6
	Pin4	-	-	-	-	Bit 1	Bit 3	Bit 5	Bit 7

■ Dimensions

• EX600-DM□E

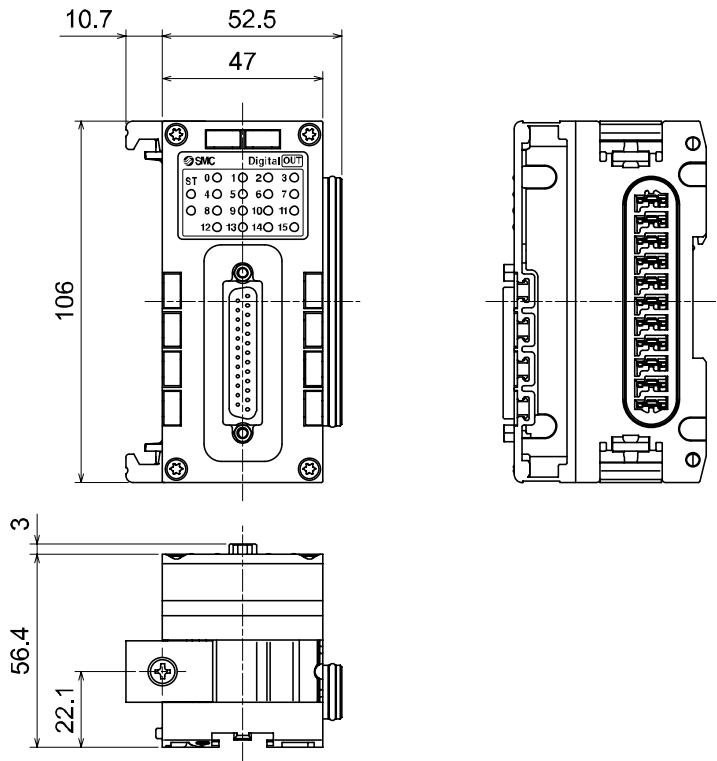

• EX600-DM□F

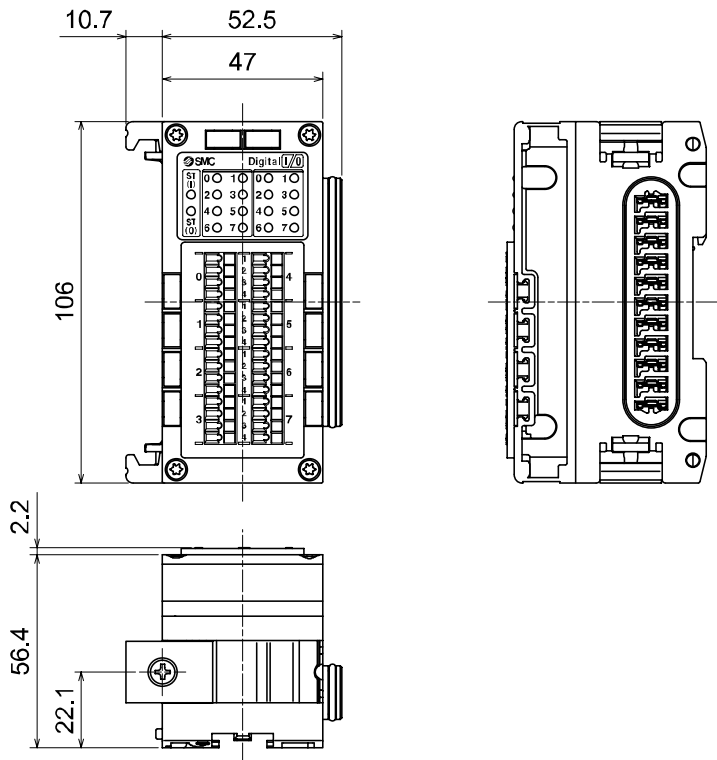

Common items

Maintenance

Turn off the power supply, stop the supplied air, exhaust the residual pressure and verify the release of air before performing maintenance.

Cleaning method

Use a soft cloth to remove stains.

For heavy stains, use a cloth soaked with diluted neutral detergent and fully squeezed, then wipe up the stains again with a dry cloth.

Do not use solvents such as benzene, thinner etc. to clean each unit.

Inspection item	Content of inspection
Connector/Electric wiring	Connect properly if the connection is loose.
Seal cap	Tighten properly if the connection is loose.
Thread for mounting and installation	If the thread is loose, re-tighten it to the specified torque.
Connection cables	If the cable is broken or any other abnormality is confirmed by appearance, replace the cable with a new one.
Supply source voltage	Check if source voltage within the specification range (24 VDC \pm 10%) is supplied.

How to reset the product for power cut or forcible de-energizing

Supply power to the product.

The output status just before the power failure is not maintained when power supply is recovered.

Start operation after confirming safety of the entire equipment.

Troubleshooting

Refer to the SI unit Operation Manual of protocol used.

Parameter Setting

Refer to the SI unit Operation Manual of protocol used.

I/O Map

Refer to the SI unit Operation Manual of protocol used.

Diagnostic

Refer to the SI unit Operation Manual of protocol used.

Accessories

Refer to the SI unit Operation Manual of protocol used.

Precautions before mounting

The units that can be connected vary depending on the product number.
Check the applicable unit type before mounting the unit.

		SI Unit			
		EX600-SPR□ (PROFIBUS DP)	EX600-SPR□A (PROFIBUS DP)	EX600-SMJ□ (CC-Link)	EX600-SEN□ (EtherNet/IP)
		EX600-SDN□ (DeviceNet)	EX600-SDN□A (DeviceNet)		
Digital unit	EX600-DX□B	○	○	○	○
	EX600-DX□C□	○	○	○	○
	EX600-DX□D	○	○	○	○
	EX600-DX□E	×	○	○	○
	EX600-DX□F	×	○	○	○
	EX600-DY□B	○	○	○	○
	EX600-DY□E	×	○	○	○
	EX600-DY□F	×	○	○	○
	EX600-DM□E	×	○	○	○
	EX600-DM□F	×	○	○	○
Analog unit	EX600-AXA	○	○	○	○
	EX600-AYA	×	○	○	○
	EX600-AMB	×	○	○	○
H.T.	EX600-HT1	○	○	○	×
	EX600-HT1A	○	○	○	○

		H.T.	
		EX600-HT1-□	EX600-HT1A-□
SI Unit	EX600-SPR□ (PROFIBUS DP)	○	○
	EX600-SPR□A (PROFIBUS DP)	○	○
	EX600-SDN□ (DeviceNet)	○	○
	EX600-SDN□A (DeviceNet)	○	○
	EX600-SMJ□ (CC-Link)	○	○
	EX600-SEN□ (EtherNet/IP)	×	○
Digital Unit	EX600-DX□B	○	○
	EX600-DX□C□	○	○
	EX600-DX□D	○	○
	EX600-DX□E	×	○
	EX600-DX□F	×	○
	EX600-DY□B	○	○
	EX600-DY□E	×	○
	EX600-DY□F	×	○
	EX600-DM□E	×	○
	EX600-DM□F	×	○
Analog Unit	EX600-AXA	○	○
	EX600-AYA	×	○
	EX600-AMB	×	○

Revision history
A: Revision (Pollution degree)

SMC Corporation

4-14-1, Sotokanda, Chiyoda-ku, Tokyo 101-0021 JAPAN
Tel: +81 3 5207 8249 Fax: +81 3 5298 5362
URL <http://www.smcworld.com>

Note: Specifications are subject to change without prior notice and any obligation on the part of the manufacturer.
© 2010-2011 SMC Corporation All Rights Reserved

