



Operation Manual

PRODUCT NAME

Fieldbus system
EtherCAT compatible SI unit

MODEL / Series/ Product Number

EX600-SEC#
EX600-ED#

SMC Corporation



Table of Contents

Safety Instructions	2
System Outline	8
Definition and terminology	9
Assembly	10
Mounting and Installation	12
Installation	12
Wiring	14
SI Unit	
Model Indication and how to order	15
Summary of Product parts	15
Mounting and Installation	16
Wiring	16
Setting and Adjustment	18
LED Display	21
Specification	23
Specifications	23
Dimensions	24
Endplate	
Model Indication and how to order	25
Summary of Product parts	25
Mounting and Installation	26
Wiring	26
Specification	27
Specifications	27
Dimensions	28
Maintenance	29
Troubleshooting	30
Parameter Setting	40
Parameter definition and setting	40
Hardware configuration	53
XML file	53
Setting using TwinCAT [®] System Manager	53
I/O Map	62
Diagnostic	63
Details of diagnostic data	66
Parameter settings using TwinCAT [®] (SDO communication)	68
Accessories	100

Safety Instructions

These safety instructions are intended to prevent hazardous situations and/or equipment damage. These instructions indicate the level of potential hazard with the labels of "Caution", "Warning" or "Danger". They are all important notes for safety and must be followed in addition to International standards (ISO/IEC) *1) and other safety regulations.

- *1) ISO 4414: Pneumatic fluid power -- General rules relating to systems
- ISO 4413: Hydraulic fluid power -- General rules relating to systems
- IEC 60204-1: Safety of machinery -- Electrical equipment of machines (Part 1: General requirements)
- ISO 10218-1992: Manipulating industrial robots -Safety.
- etc.

-  **Caution** : CAUTION indicates a hazard with a low level of risk which, if not avoided, could result in minor or moderate injury.
-  **Warning** : WARNING indicates a hazard with a medium level of risk which, if not avoided, could result in death or serious injury.
-  **Danger** : DANGER indicates a hazard with a high level of risk which, if not avoided, will result in death or serious injury.

Warning

1. The compatibility of the product is the responsibility of the person who designs the equipment or decides its specifications.

Since the product specified here is used under various operating conditions, its compatibility with specific equipment must be decided by the person who designs the equipment or decides its specifications based on necessary analysis and test results. The expected performance and safety assurance of the equipment will be the responsibility of the person who has determined its compatibility with the product. This person should also continuously review all specifications of the product referring to its latest catalog information, with a view to giving due consideration to any possibility of equipment failure when configuring the equipment.

2. Only personnel with appropriate training should operate machinery and equipment.

The product specified here may become unsafe if handled incorrectly. The assembly, operation and maintenance of machines or equipment including our products must be performed by an operator who is appropriately trained and experienced.

3. Do not service or attempt to remove product and machinery/equipment until safety is confirmed.

1. The inspection and maintenance of machinery/equipment should only be performed after measures to prevent falling or runaway of the driven objects have been confirmed.
2. When the product is to be removed, confirm that the safety measures as mentioned above are implemented and the power from any appropriate source is cut, and read and understand the specific product precautions of all relevant products carefully.
3. Before machinery/equipment is restarted, take measures to prevent unexpected operation and malfunction.

4. Contact SMC beforehand and take special consideration of safety measures if the product is to be used in any of the following conditions.

1. Conditions and environments outside of the given specifications, or use outdoors or in a place exposed to direct sunlight.
2. Installation on equipment in conjunction with atomic energy, railways, air navigation, space, shipping, vehicles, military, medical treatment, combustion and recreation, or equipment in contact with food and beverages, emergency stop circuits, clutch and brake circuits in press applications, safety equipment or other applications unsuitable for the standard specifications described in the product catalog.
3. An application which could have negative effects on people, property, or animals requiring special safety analysis.
4. Use in an interlock circuit, which requires the provision of double interlock for possible failure by using a mechanical protective function, and periodical checks to confirm proper operation.

Caution

The product is provided for use in manufacturing industries.

The product herein described is basically provided for peaceful use in manufacturing industries. If considering using the product in other industries, consult SMC beforehand and exchange specifications or a contract if necessary.
If anything is unclear, contact your nearest sales branch.

Limited warranty and Disclaimer/Compliance Requirements

The product used is subject to the following "Limited warranty and Disclaimer" and "Compliance Requirements".

Read and accept them before using the product.

Limited warranty and Disclaimer

1. The warranty period of the product is 1 year in service or 1.5 years after the product is delivered. *2)
Also, the product may have specified durability, running distance or replacement parts. Please consult your nearest sales branch.
2. For any failure or damage reported within the warranty period which is clearly our responsibility, a replacement product or necessary parts will be provided.
This limited warranty applies only to our product independently, and not to any other damage incurred due to the failure of the product.
3. Prior to using SMC products, please read and understand the warranty terms and disclaimers noted in the specified catalog for the particular products.

*2) Vacuum pads are excluded from this 1 year warranty.

A vacuum pad is a consumable part, so it is warranted for a year after it is delivered.

Also, even within the warranty period, the wear of a product due to the use of the vacuum pad or failure due to the deterioration of rubber material are not covered by the limited warranty.

Compliance Requirements

1. The use of SMC products with production equipment for the manufacture of weapons of mass destruction (WMD) or any other weapon is strictly prohibited.
2. The exports of SMC products or technology from one country to another are governed by the relevant security laws and regulation of the countries involved in the transaction. Prior to the shipment of a SMC product to another country, assure that all local rules governing that export are known and followed.

Operator

- ◆ This operation manual is intended for those who have knowledge of machinery using pneumatic equipment, and have sufficient knowledge of assembly, operation and maintenance of such equipment. Only those persons are allowed to perform assembly, operation and maintenance.
- ◆ Read and understand this operation manual carefully before assembling, operating or providing maintenance to the product.

■ Precautions

Warning

- Do not disassemble, modify (including changing the printed circuit board) or repair.
An injury or failure can result.
- Do not operate or set with wet hands.
This may lead to an electric shock.
- Do not operate the product outside of the specifications.
Do not use for flammable or harmful fluids.
Fire, malfunction, or damage to the product can result.
Verify the specifications before use.
- Do not operate in an atmosphere containing flammable or explosive gases.
Fire or an explosion can result.
This product is not designed to be explosion proof.
- If using the product in an interlocking circuit:
 - Provide a double interlocking system, for example a mechanical system.
 - Check the product regularly for proper operation.Otherwise malfunction can result, causing an accident.
- The following instructions must be followed during maintenance:
 - Turn off the power supply.
 - Stop the air supply, exhaust the residual pressure and verify that the air is released before performing maintenance.Otherwise an injury can result.

Caution

- When handling, assembling or replacing the units:
 - Avoid touching any sharp metal parts of the connectors for connecting units.
 - When assembling units, take care not to get any fingers caught between units.
Injury can result.
 - When disassembling units, take care to avoid excessive force.
The connection parts of the unit are firmly joined with seals and injury can result.
- After maintenance is complete, perform appropriate functional inspections.
Stop operation if the equipment does not function properly.
Safety cannot be assured in the case of unexpected malfunction.
- Provide grounding to assure the safety and noise resistance of the Fieldbus system.
Individual grounding should be provided close to the product with a short cable.

■ NOTE

- Follow the instructions given below when designing, selecting and handling the product.
 - The instructions on design and selection (installation, wiring, environment, adjustment, operation, maintenance, etc.) described below must also be followed.
 - *Product specifications
 - The direct current power supply to combine should be UL1310 Class2 power supply when conformity to UL is necessary.
 - Use the specified voltage.
Otherwise failure or malfunction can result.
 - The power supply for the unit should be 0 V as the standard for both the power supply for outputs and the power supply for inputs and control.

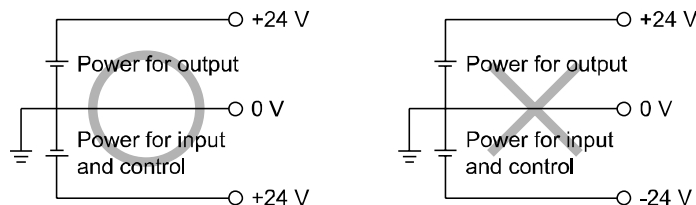

- Reserve a space for maintenance.
Allow sufficient space for maintenance when designing the system.
- Do not remove any nameplates or labels.
This can lead to incorrect maintenance, or misreading of the operation manual, which could cause damage or malfunction to the product.
It may also result in non-conformity to safety standards.
- Beware of inrush current when the power supply is turned on.
Some connected loads can apply an initial charge current which will activate the over current protection function, causing the unit to malfunction.

●Product handling

*Installation

- Do not drop, hit or apply excessive shock to the SI unit.

Otherwise damage to the product can result, causing malfunction.

- Tighten to the specified tightening torque.

If the tightening torque is exceeded the mounting screws may be broken.

IP67 protection cannot be guaranteed if the screws are not tightened to the specified torque.

- If a large manifold valve is mounted, lift the unit so that stress is not applied to the connecting part while transporting.

The stress may cause breakage of the connecting part. The unit may become very heavy depending on the combination. Transportation/installation shall be performed by multiple operators.

- Never mount a product in a location that will be used as a foothold.

The product may be damaged if excessive force is applied by stepping or climbing onto it.

*Wiring

- Avoid repeatedly bending or stretching the cables, or placing heavy load on them.

Repetitive bending stress or tensile stress can cause breakage of the cable.

- Wire correctly.

Incorrect wiring can break the product.

- Do not perform wiring while the power is on.

Otherwise damage to the Fieldbus system and/or input or output device can result, causing malfunction.

- Do not route wires and cables together with power or high voltage cables.

Otherwise the Fieldbus system and/or input or output device can malfunction due to interference of noise and surge voltage from power and high voltage cables to the signal line.

Route the wires (piping) of the Fieldbus system and/or input or output device separately from power or high voltage cables.

- Confirm proper insulation of wiring.

Poor insulation (interference from another circuit, poor insulation between terminals, etc.) can lead to excess voltage or current being applied to the product, causing damage.

- Take appropriate measures against noise, such as using a noise filter, when the Fieldbus system is incorporated into equipment.

Otherwise noise can cause malfunction.

*Environment

- Select the proper type of protection according to the environment of operation.

IP67 protection is achieved when the following conditions are met.

(1)The units are connected properly with fieldbus cable with M12 connector and power cable with M12 (M8) connector.

(2)Suitable mounting of each unit and manifold valve.

(3)Be sure to fit a waterproof cap on any unused connectors.

If using in an environment that is exposed to water splashes, please take measures such as using a cover.

Do not use in an environment where moisture or water vapor are present. Otherwise failure and malfunction can result.

- Do not use in a place where the product could be splashed by oil or chemicals.

If the product is to be used in an environment containing oils or chemicals such as coolant or cleaning solvent, even for a short time, it may be adversely affected (damage, malfunction etc.).

- Do not use the product in an environment where corrosive gases or fluids could be splashed.

Otherwise damage to the product and malfunction can result.

- Do not use in an area where surges are generated.

If there is equipment generating large surge near the unit (magnetic type lifter, high frequency inductive furnace, welding machine, motor, etc.), this can cause deterioration of the internal circuitry element of the unit or result in damage. Take measures against the surge sources, and prevent the lines from coming into close contact.

- When a surge-generating load such as a relay, valve or lamp is driven directly, use a product with a built-in surge absorbing element.
Direct drive of a load generating surge voltage can damage the unit.
- The product is CE marked, but not immune to lightning strikes. Take measures against lightning strikes in the system.
- Prevent foreign matter such as dust or wire debris from getting inside the product.
- Mount the product in a place that is not exposed to vibration or impact.
Otherwise failure or malfunction can result.
- Do not use the product in an environment that is exposed to temperature cycle.
Heat cycles other than ordinary changes in temperature can adversely affect the inside of the product.
- Do not expose the product to direct sunlight.
If using in a location directly exposed to sunlight, shade the product from the sunlight.
Otherwise failure or malfunction can result.
- Keep within the specified ambient temperature range.
Otherwise malfunction can result.
- Do not operate close to a heat source, or in a location exposed to radiant heat.
Otherwise malfunction can result.

***Adjustment and Operation**

- Set the switches by using a sharp-pointed screwdriver etc. When setting the switch, do not touch other unrelated parts.
This can cause parts damage or malfunction due to a short circuit.
- Perform settings suitable for the operating conditions.
Incorrect setting can cause operation failure.
(Refer to page 18 "setting and Adjustment".)
- Please refer to the PLC manufacturer's manual etc. for details of programming.
For the PLC protocol and programming refer to the relevant manufacturer's documentation.

***Maintenance**

- Turn off the power supply, stop the supplied air, exhaust the residual pressure and verify the release of air before performing maintenance.
There is a risk of unexpected malfunction.
- Perform regular maintenance and inspections.
There is a risk of unexpected malfunction.
- After maintenance is complete, perform appropriate functional inspections.
Stop operation if the equipment does not function properly.
Otherwise safety is not assured due to an unexpected malfunction or incorrect operation.
- Do not use solvents such as benzene, thinner etc. to clean each unit.
They could damage the surface of the body and erase the markings on the body.
Use a soft cloth to remove stains.
For heavy stains, use a cloth soaked with diluted neutral detergent and fully squeezed, then wipe up the stains again with a dry cloth.

System Outline

•System configuration

The EX600 range of units can be connected to various types of fieldbus to realize the reduction of input or output device wiring and the distributed control system. The unit communicates with the fieldbus through the SI unit. One SI unit can be connected with manifold valves with up to 32 outputs and the input • output • I/O units with maximum 10 units.

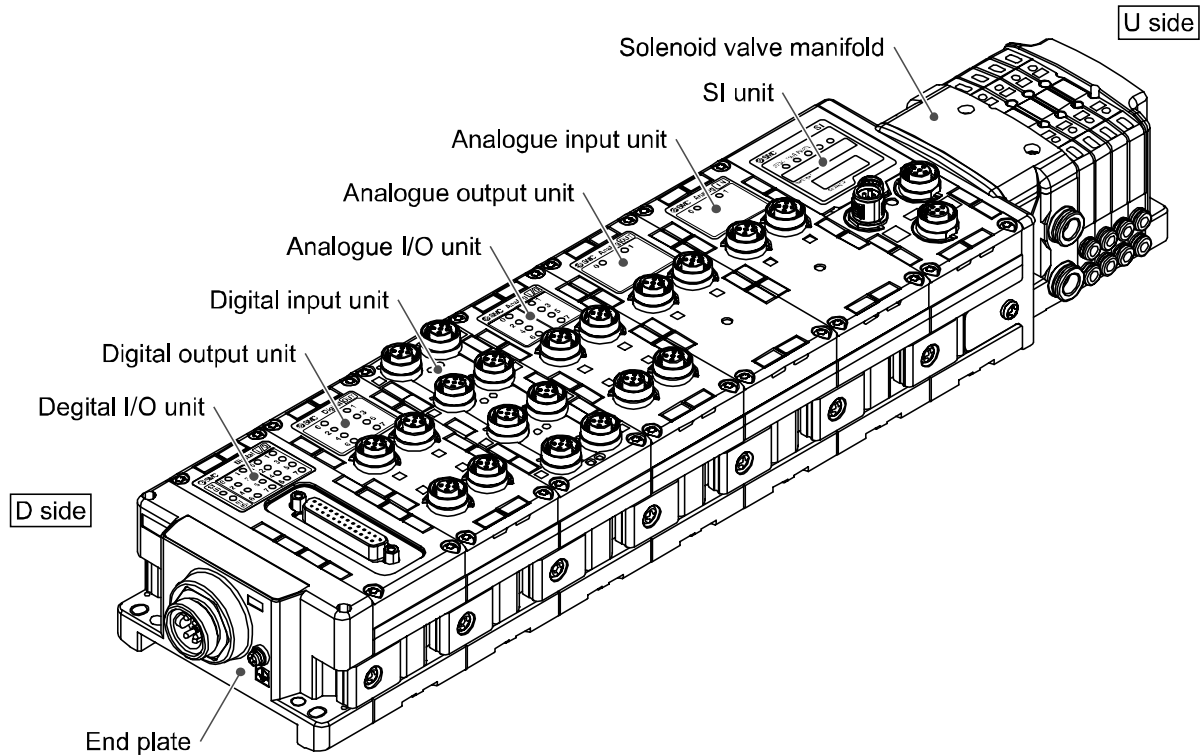

SI unit: Performs fieldbus communication and solenoid valve manifold ON/OFF output.

Digital input unit: For connecting sensors with switch output capability. PNP and NPN types are available.

Digital output unit: For connecting output device such as solenoid valves, lamps, buzzers, etc. PNP and NPN types are available.

Digital I/O unit: This unit has both digital input and output functions. PNP and NPN types are available.

Analogue input unit: For connecting sensors with analogue output capability.

Analogue output unit: This can be connected to the equipment which can read analogue input.

Analogue I/O unit: This unit has both analogue input and output functions.

End plate: Connected at EX600 Manifold's D side, incorporating the power supply connection.

Solenoid valve manifold: An assembly of solenoid valves. One connector is used as the electric connection to all connected valves.

■ Definition and terminology

	Terminology	Definition
A	AD value	The signal from the analogue input device is converted to digital, and displayed in decimal and hexadecimal. These hexadecimal and decimal values are also outputted to the analogue output device.
C	Communication speed	A speed at which data is sent and received in fieldbus etc. It depends on an equipment (PLC etc.) at high side and is indicated by bps (bit per second).
	Current consumption	The current necessary to operate each unit.
D	DIN rail	A metal rail conforming with DIN (German) standard.
	D Side	The side connected to the end plate when the product is connected to a manifold.
E	Enclosure (IP□□)	Abbreviation of international (ingress) protection. A standard related to the protection from external objects (hands, steel ball, steel wire, dust, water, etc.) applied to the product.
F	F.E.	Abbreviation of functional earth.
	Fieldbus	The protocol that uses digital communication to exchange signals between field equipment (instruments and actuators) running on site and a PLC.
H	Handheld Terminal (H.T.)	Abbreviation of handheld terminal. It is possible to monitor the input/output data and diagnostic data and set parameters.
I	Idle	Idle refers to the SI unit operation mode, which is either in the default, pre-operational or safe operational modes. For details, Refer to manuals of each PLC maker.
M	Manifold	A form consisting of multiple components. A form made by combining multiple components
N	NPN input	Takes the sensor output that uses the NPN transistor to the signal output line.
	NPN output	The output type that uses an NPN transistor to operate output device. It is also known as a positive common type since a positive potential is applied to the power supply line.
	Number of inputs	The number of points that can receive information from input device (sensor, switch, etc.).
	Number of outputs	The number of points that can operate output device (solenoid valve, light, motor, etc.)
O	Open circuit detection	A diagnosis function to detect if the input or output device wiring is disconnected.
P	PLC	Abbreviation of programmable logic controller. A digital computer used for automation of electromechanical processes.
	PNP input	Takes the sensor output that uses the PNP transistor to the signal output part.
	PNP output	The output type that uses a PNP transistor to operate output device. It is also known as a negative common type since a negative potential is applied to the power supply line.
S	Short circuit detection	A diagnosis function to detect an over current due to the short circuit of the output and/or power supply positive line with respect to the GND line.
	Short circuit protection	A function to protect the internal circuit from being broken by an over current due to the short circuit of the output and/or power supply positive line with respect to the GND line.
	SI unit	Abbreviation of serial interface unit. A unit connected to a PLC to communicate input and output data.
U	U Side	The side connected to the solenoid valve when the product is connected to a manifold.

Assembly

•Assembling the unit as a manifold

*: If the unit was purchased as a manifold, the work described in this section is not necessary.

(1)Connect a unit to the end plate.

Digital and Analogue I/O units can be connected in any order.

Tighten the joint brackets to a torque of 1.5 to 1.6 Nm.

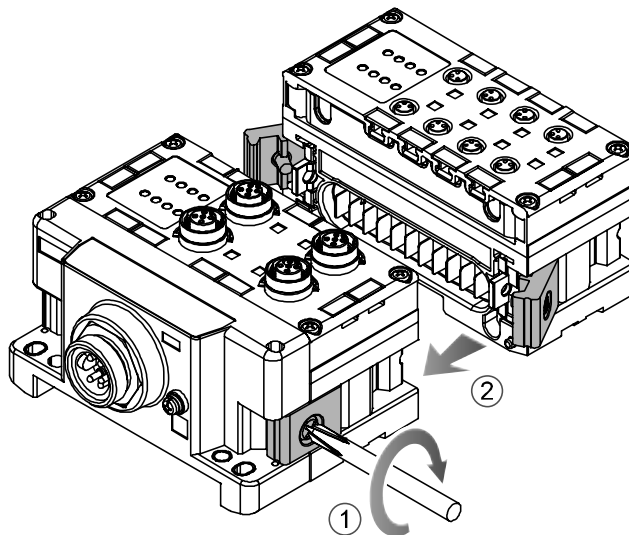

(2)Add more I/O units.

Up to 10 units (including the SI unit) can be connected to one manifold.

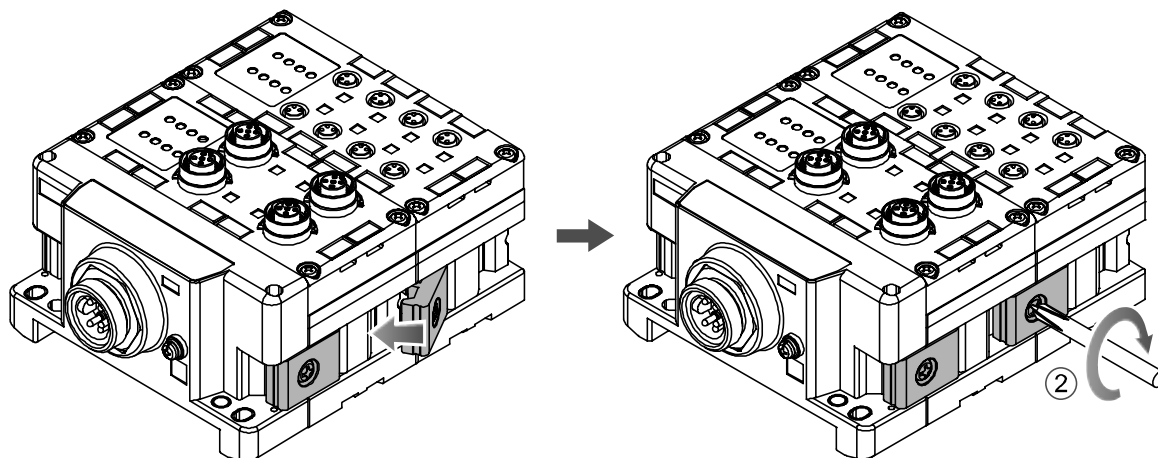

(3)Connecting the SI unit.

After connecting the required I/O units, connect the SI unit.

The method is as above in (1), (2).

(4) Mounting the valve plate.

Mount the valve plate (EX600-ZMV□) to the valve manifold using the valve set screws. (M3 x 8)
Apply 0.6 to 0.7 Nm tightening torque to the screws.

┆ Screw mounting place	┆
┆ SV	┆ : 2 places
┆ S0700	┆ : 2 places
┆ VQC1000	┆ : 2 places
┆ VQC2000	┆ : 3 places
┆ VQC4000	┆ : 4 places
┆ SY	┆ : 2 places

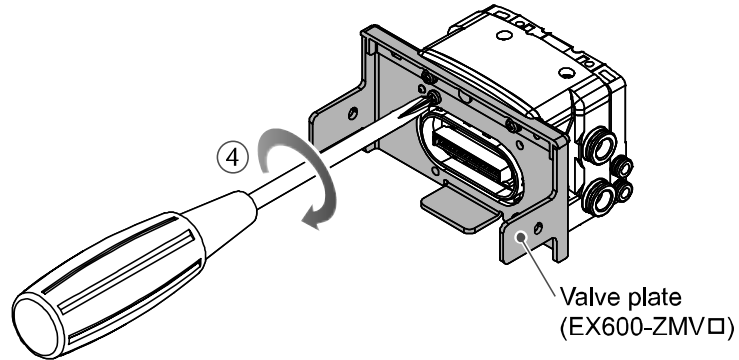

(5) Connect the SI unit to the valve manifold.

Insert the valve plate into the valve plate mounting groove on the side of the SI unit.
Fix using the valve plate screws (M4 x 6) supplied, to a torque of 0.7 to 0.8 Nm.

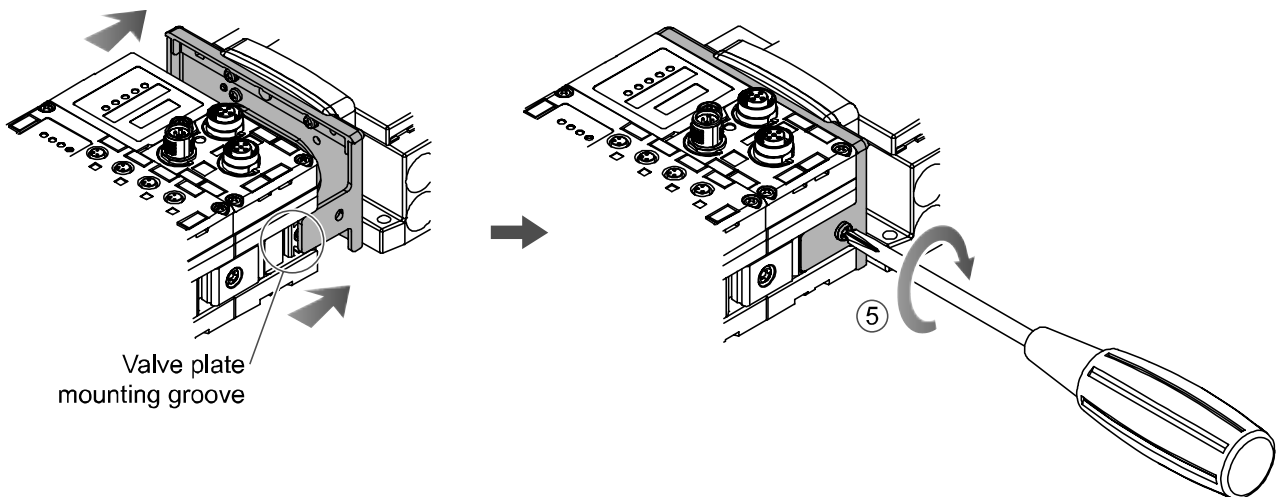

● Precautions for handling

- Please do not connect the unit while the power supply is active. It will cause equipment damage.
- Take care not to drop the nuts of Joint bracket.

Mounting and Installation

■ Installation

• Direct mounting

- (1) When joining six or more units, fix the middle part of the complete EX600 unit with an intermediate reinforcing brace (EX600-ZMB1) before mounting, using 2-M4 x 5 screws.
Tightening torque: 0.7 to 0.8 Nm.

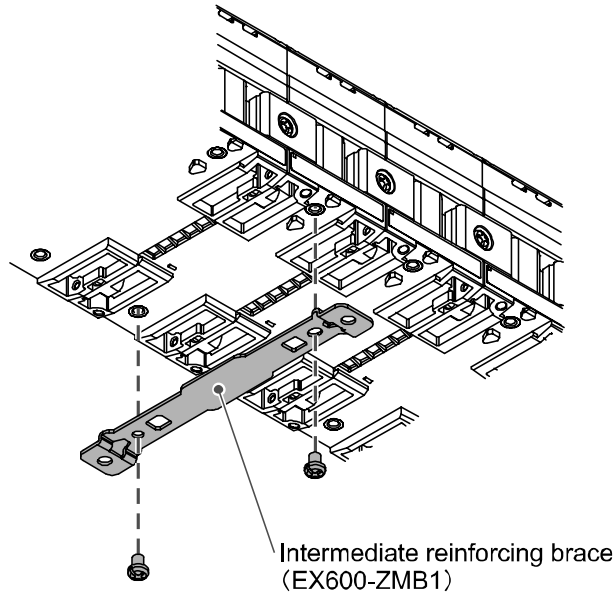

- (2) Mount and tighten the end plate at one end of the unit. (M4)

Tightening torque: 0.7 to 0.8 Nm.

Fix the end plate at the valve side while referring to the operation manual of the corresponding valve manifold.

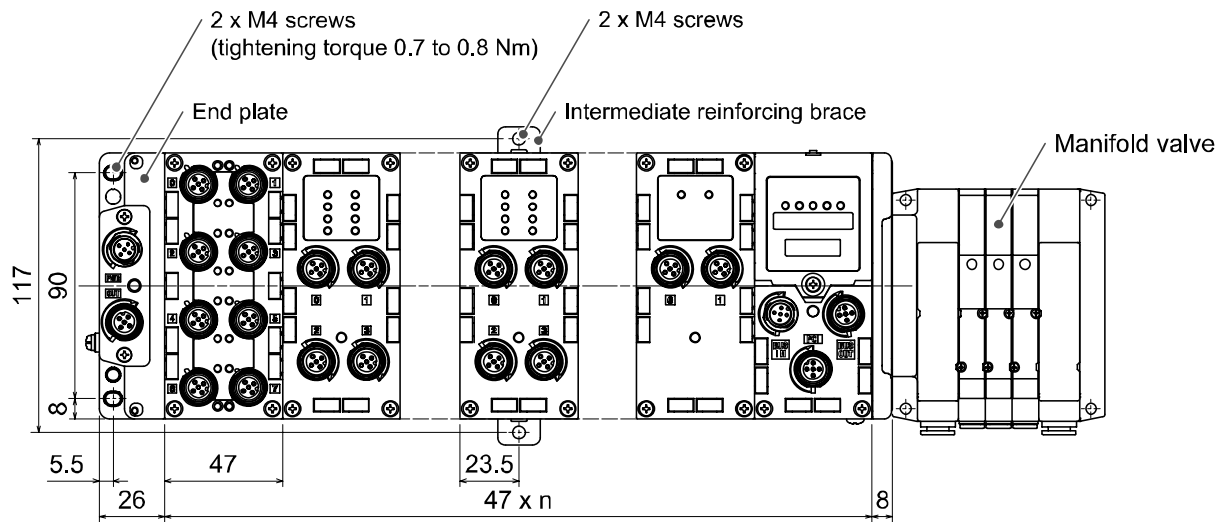

n (Number of connected units) 10

•DIN rail mounting

(Not available for SY series valves. Refer to the SY catalog.)

(1)When joining six or more units, fix the middle part of the complete EX600 unit with an intermediate reinforcing brace (EX600-ZMB2) before mounting, using 2-M4 x 6 screws.

Tightening torque: 0.7 to 0.8 Nm.

(2)Mount the end plate bracket (EX600-ZMA2) to the end plate at the opposite end to the valves, using 2-M4 x 14 screws.

Tightening torque: 0.7 to 0.8 Nm.

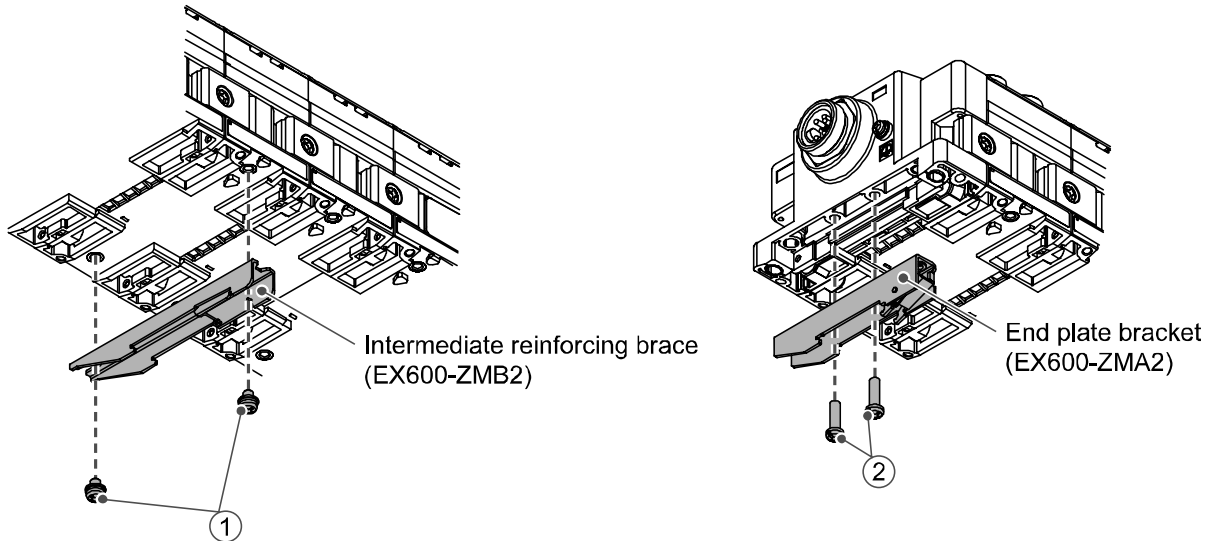

(3)Hook the DIN rail mounting groove on to the DIN rail.

(4)Press the manifold using its side hooked to the DIN rail as a fulcrum until the manifold is locked.

(5)Fix the manifold by tightening the DIN rail fixing screws of the EX600-ZMA2. (M4 x 20)

Tightening torque: 0.7 to 0.8 Nm.

The tightening torque at the valve side depends on the valve type.

Refer to the operation manual of the corresponding valve manifold.

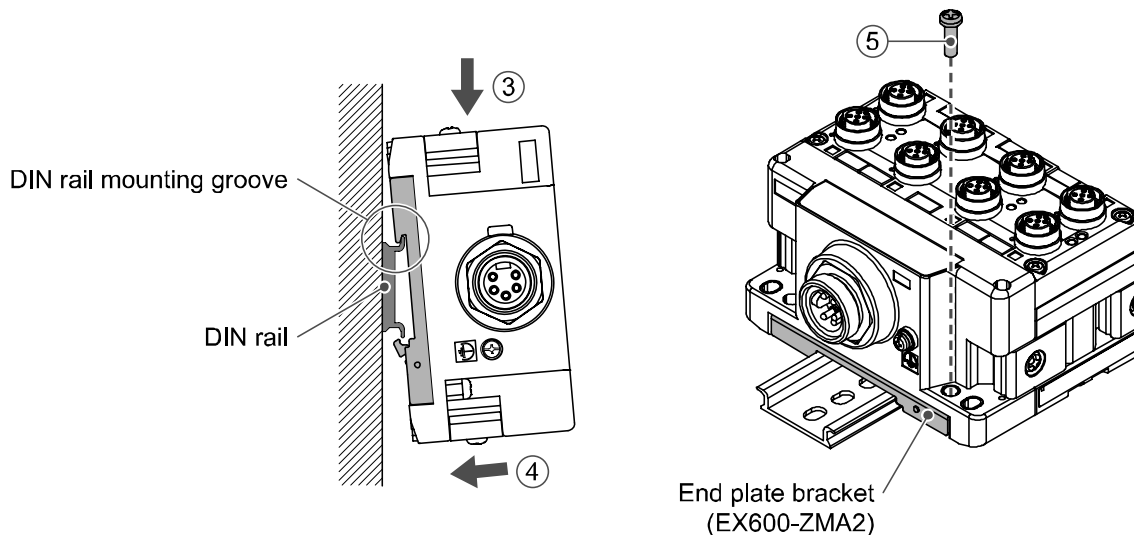

■Wiring

- Connect the M12 connector cable.

The M12 SPEEDCON connector connection method is explained below.

(1)Align mark B on the metal bracket of the cable connector (plug) with mark A.

(2)Align with mark C on the unit and insert the connector vertically.

If they are not aligned, the connector cannot be connected correctly.

(3)When mark B has been turned 180 degrees (1/2 turn), wiring is complete. Confirm that the connection is not loose. If turned too far, it will become difficult to remove the connector.

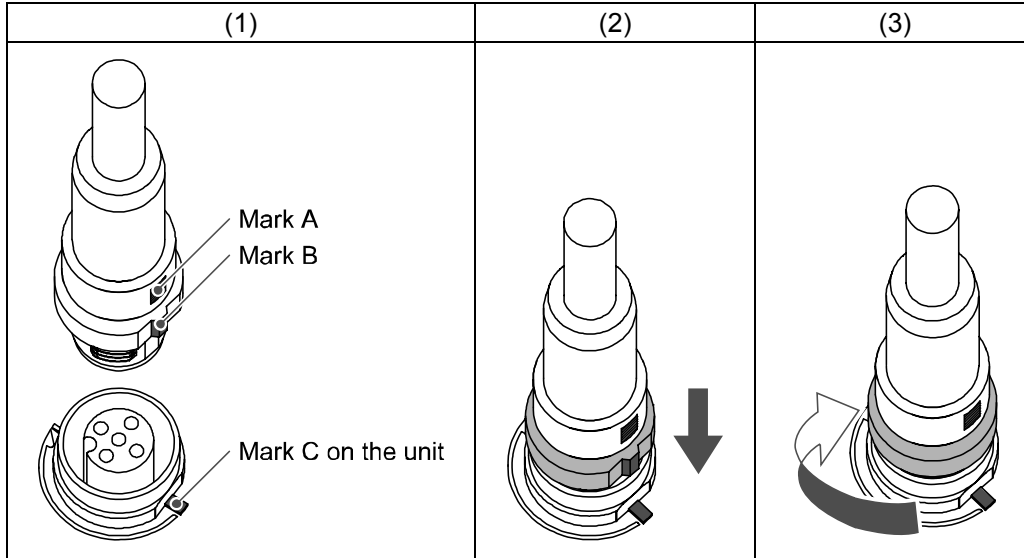

- Mounting the marker

The signal name of the input or output devices and unit address can be written on the marker, and can be installed on each unit.

Mount the marker (EX600-ZT1) into the marker groove as required.

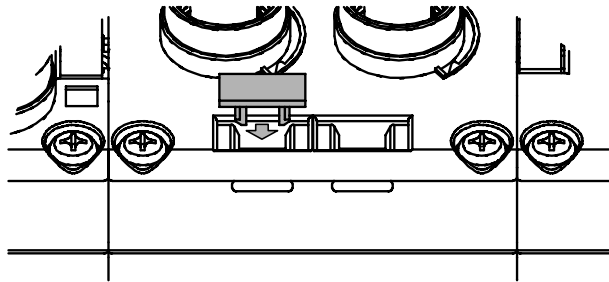

SI unit

Model Indication and how to order

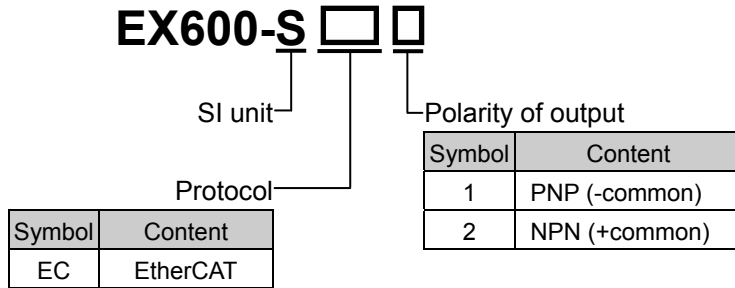

Summary of Product parts

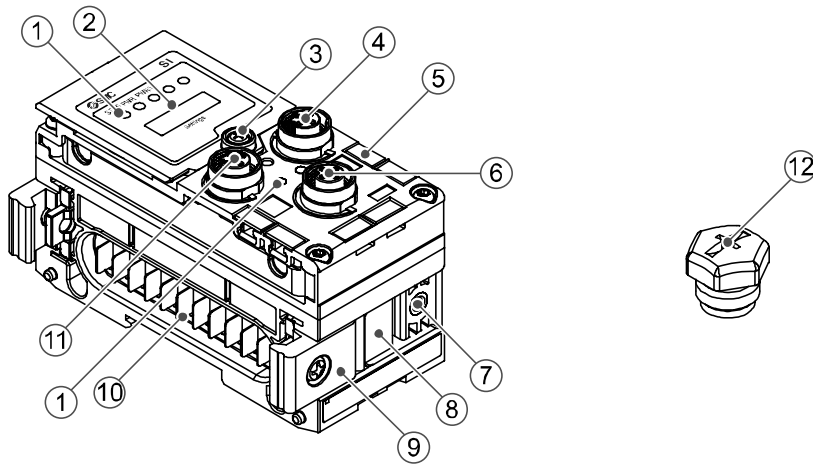

No.	Description	Function
1	Status display LED	Displays the status of the unit.
2	Display cover	Open to access the setting switches.
3	Display cover screw	Screw to open the display cover.
4	Connector (BUS OUT)	Connector for fieldbus outputs.
5	Marker groove	Groove for an identification marker.
6	Connector (PCI)	Connector for Handheld Terminal.
7	Valve plate mounting hole	Holes for fixing the valve plate.
8	Valve plate mounting groove	Groove for mounting the valve plate.
9	Joint bracket	Bracket for joining to adjacent units.
10	Unit connector (Plug)	Connector for signals and power supplies to adjacent units.
11	Connector (BUS IN)	Connector for fieldbus inputs.
12	Seal cap (2 pcs.)	Fitted to unused connectors. (BUS OUT and PCI)

*: The Handheld Terminal have to use EX600-HT1A. (EX600-HT1 cannot be used.)

Mounting and Installation

■Wiring

•Connector pin assignment

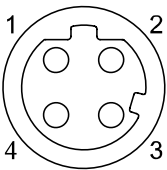
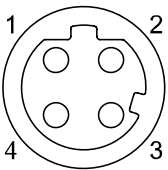
Configuration		Pin number	Signal name
BUS IN	BUS OUT		
		1	TD+
		2	RD+
		3	TD-
		4	RD-

●Precautions for handling

Be sure to fit a seal cap on any unused connectors. Proper use of the seal cap enables the enclosure to achieve IP67 specification.

Connect the "BUS IN" connector to the upstream device (PC, PLC etc.) and connect the "BUS OUT" connector to the downstream device.

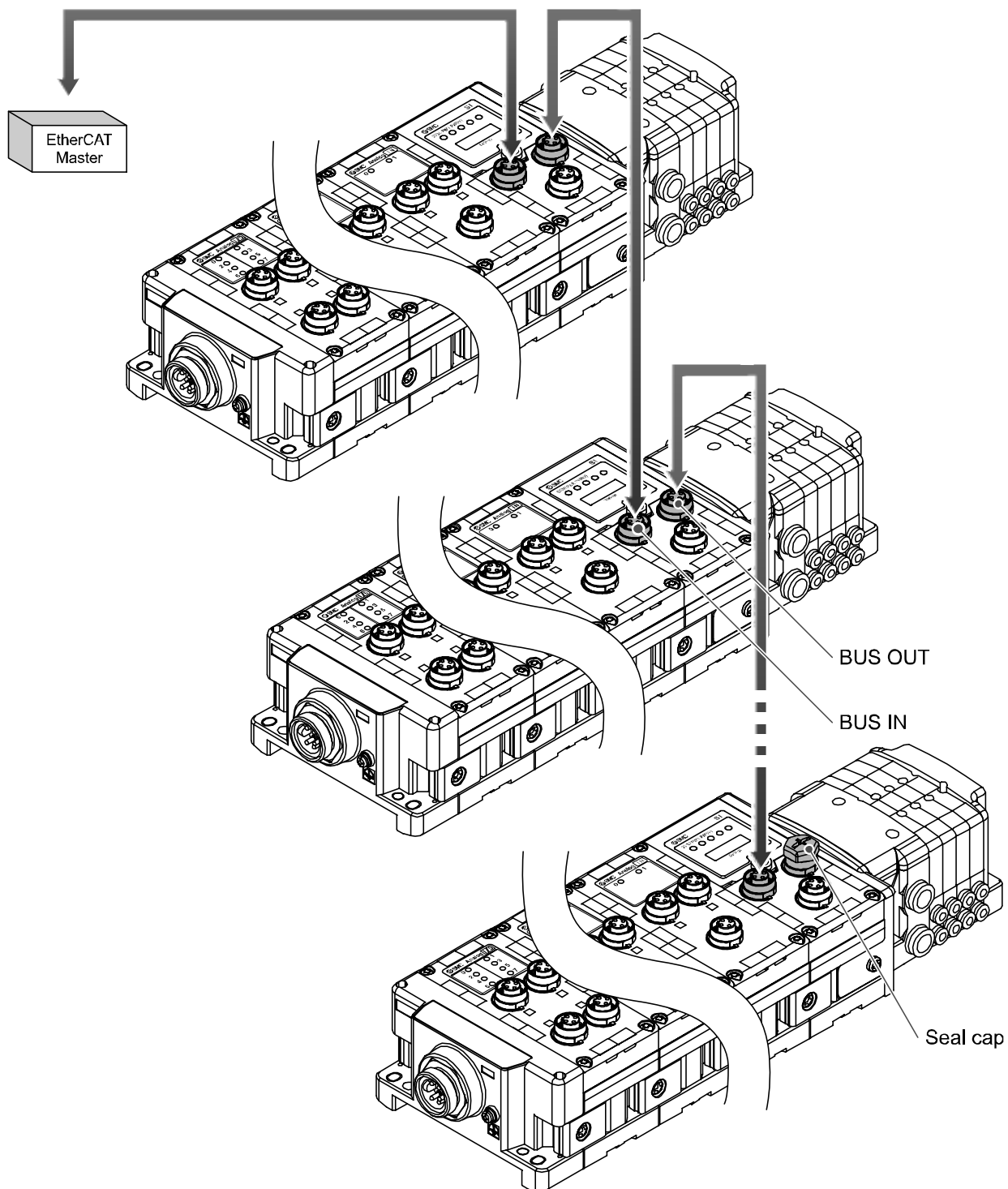

Setting and Adjustment

•Switch setting

- (1) Loosen the display cover screw.
- (2) Open the display cover using a flat head screwdriver, etc.

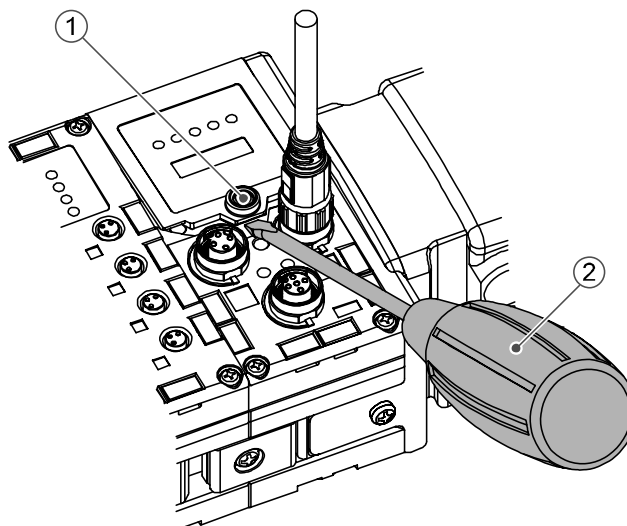

- (3) Set the switch using a small watchmaker's screwdriver with a thin blade, referring to the setting of switch on the following pages.
- (4) After setting the switch, tighten the display cover tightening screw in the reverse order of the above procedure. (Tightening torque: 0.3 to 0.4 Nm)

•Precautions for handling

- Turn off the power supply whilst setting the switch.
- If there is foreign matter or water droplets around the display cover, clean it off before opening the cover.
- When setting the switch, do not touch other unrelated parts. This can cause parts damage or malfunction due to a short circuit.
- All default settings are OFF. Perform the setting of the switch before using this product.
- When introducing power supply, switch setting will become effective.

- V_SEL switch: A function to select the number of occupied valve outputs.
Select the number of outputs (size) occupied by the SI unit.



Settings

Settings		Content	SI unit output data size
1	2		
OFF	OFF	Number of valves = 32 outputs (Default setting)	4 byte
OFF	ON	Number of valves = 24 outputs	3 byte
ON	OFF	Number of valves = 16 outputs	2 byte
ON	ON	Number of valves = 8 outputs	1 byte

*: Set the number of occupied valve outputs to at least the number of valves used.

- Diagnostics switch: Allocates the diagnostic data to the input data.

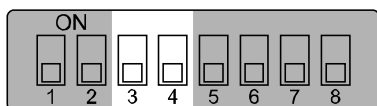

Settings

Settings		Mode	Content	Diagnostic size set for the input
3	4			
OFF	OFF	0	Input data only (Default setting)	0 byte
OFF	ON	1	Input data + System diagnosis	4 byte
ON	OFF	2	Input data + System diagnosis + Unit diagnosis	6 byte
ON	ON			

- HOLD/CLEAR switch: Sets the output status when the fieldbus has a communication error or is in idle state.

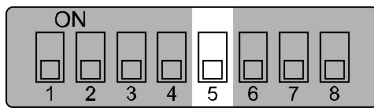

Settings

Settings	Content
5	
OFF	Output is OFF. (Default setting)
ON	Holds the output.

*: Refer to "Parameter Setting" (page 40), for the further details.

*: A communication error refers to the SI unit, which is in interrupted communication state. Idle refers to the SI unit operation mode, which is either in the default, pre-operational or safe operational modes.

- Configuration memory switch: When the manifold configuration memory switch is set ON and the power supply is switched ON, the system will compare the stored configuration with the manifold configuration. If the configuration is different, diagnostic error will be generated.

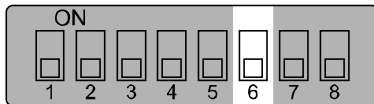

Settings

Settings	Content
6	
OFF	Normal operation mode (Default setting)
ON	Configuration memory mode

- Timing to memorize the configuration → When power supply for control and input is turned on, with the switch above turned OFF.
- Timing to compare the configuration → When power supply for control and input is turned on, with the switch above turned ON.

●Precautions for handling

- Handle the switch with care. Excessive force can break the switch.
- 7, 8 of the Settings switch are not used.

LED Display

The status display LED displays the power supply and communication status.
Various kinds of status can be checked as follows:

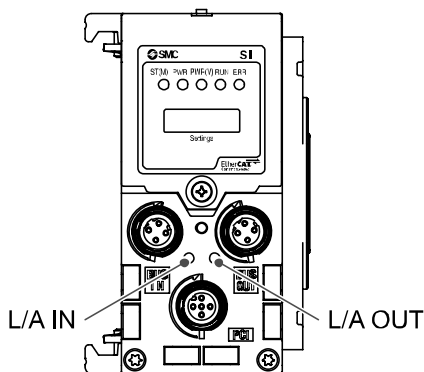

Display	Content
ST(M)	Displays the diagnostic status of the unit.
PWR	Displays the status of the power supply voltage for control and input.
PWR(V)	Displays the status of the power supply voltage for outputs.
RUN	Displays the module status.
ERR	Displays the network status.

	Content
L/A IN	Displays the communication status of the BUS IN side.
L/A OUT	Displays the communication status of the BUS OUT side.

•SI unit common status

LED display	Content
ST(M) PWR PWR(V) ○ ○ ○ OFF.	The power supply for control and input is OFF.
ST(M) PWR PWR(V) ● ● ● Green LEDs are ON.	The unit is in normal operation.
ST(M) PWR PWR(V) ● ○ ○ Red ST(M) LED is ON.	A component failure inside the SI unit.
ST(M) PWR PWR(V) ○ ● ○ Red PWR LED is ON.	The power supply voltage for control and input is abnormal.
ST(M) PWR PWR(V) ○ ○ ● Red PWR(V) LED is ON.	The power supply voltage for outputs is abnormal.
ST(M) PWR PWR(V) ● ○ ○ Green ST(M) LED is flashing.	A unit other than the SI unit has been detected.
ST(M) PWR PWR(V) ● ○ ○ Red ST(M) LED is flashing.	Either of the following conditions: •The valve ON/OFF counter has exceeded the set value. •The valve is short circuited or disconnected.
ST(M) PWR PWR(V) ● ○ ○ Red/Green ST(M) LED is flashing alternately.	Either of the following conditions: •Connection error between units has occurred. •Configuration memory error has occurred.

•EtherCAT status

LED display	LED state	Content
RUN ● (Green)	OFF	Initialized status
	Flash *	Pre-operational status
	Single Flash *	Safe operational status
	ON	Operational status
ERR ● (Red)	OFF	No communication error
	Flash *	Communication setup error
	Double Flash *	Communication error (application watchdog timeout)
(L/A IN) ● (Green)	OFF	BUS IN side : No Link, No Activity
	ON	BUS IN side : Link, No Activity
	Flickering *	BUS IN side : Link, Activity
(L/A OUT) ● (Green)	OFF	BUS OUT side: No Link, No Activity
	ON	BUS OUT side: Link, No Activity
	Flickering *	BUS OUT side: Link, Activity

*: Refer to the table below for the LED state.

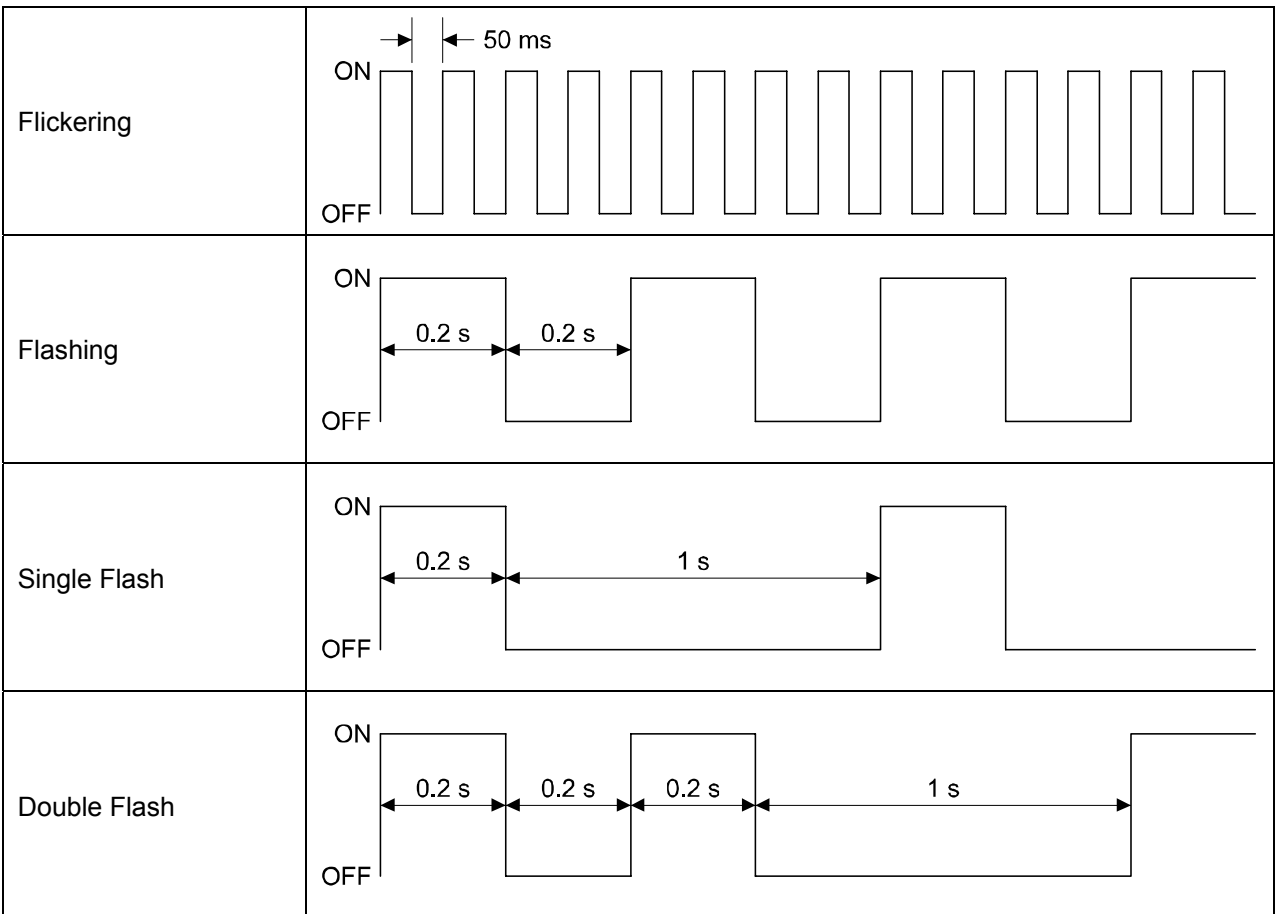

Specification

■ Specifications

Model		EX600-SEC1	EX600-SEC2
Communication	Protocol	EtherCAT (Conformance Test Record V.1.2)	
	Communication speed	100 Mbps	
	Occupied area (Number of inputs/outputs)	(512 inputs/512 outputs) Max.	
Internal current consumption (The power supply for control and input)		100 mA or less	
Output	Polarity of output	PNP (-common)	NPN (+common)
	Number of Outputs	32 outputs (8/16/24/32 outputs selectable)	
	Connected load	24 VDC 1.5 W (SMC) solenoid valve with circuit protection of surge voltage	
	Power supply	24 VDC 2 A	
	Output condition at the time of communication error	HOLD/CLEAR/Force ON	
	Protective function	Short circuit protection	
Environment	Enclosure	IP67 (With manifold assembled) *1	
	Operating temperature range	-10 to 50 °C *2	
	Storage temperature range	-20 to 60 °C	
	Operating humidity range	35 to 85%R.H. (No condensation)	
	Withstand voltage	500 VAC for 1 minute between external terminals and F.E.	
	Insulation resistance	500 VDC, 10 MΩ or more between external terminals and F.E.	
	Pollution degree	For use in Pollution Degree 3 Environment (UL508)	
Standard		CE, UL(CSA), RoHS	
Weight		300 g	

*1: All unused connectors must have a seal cap fitted.

*2: The UL compliant temperature is 0 to 50 °C.

■Dimensions (in mm)

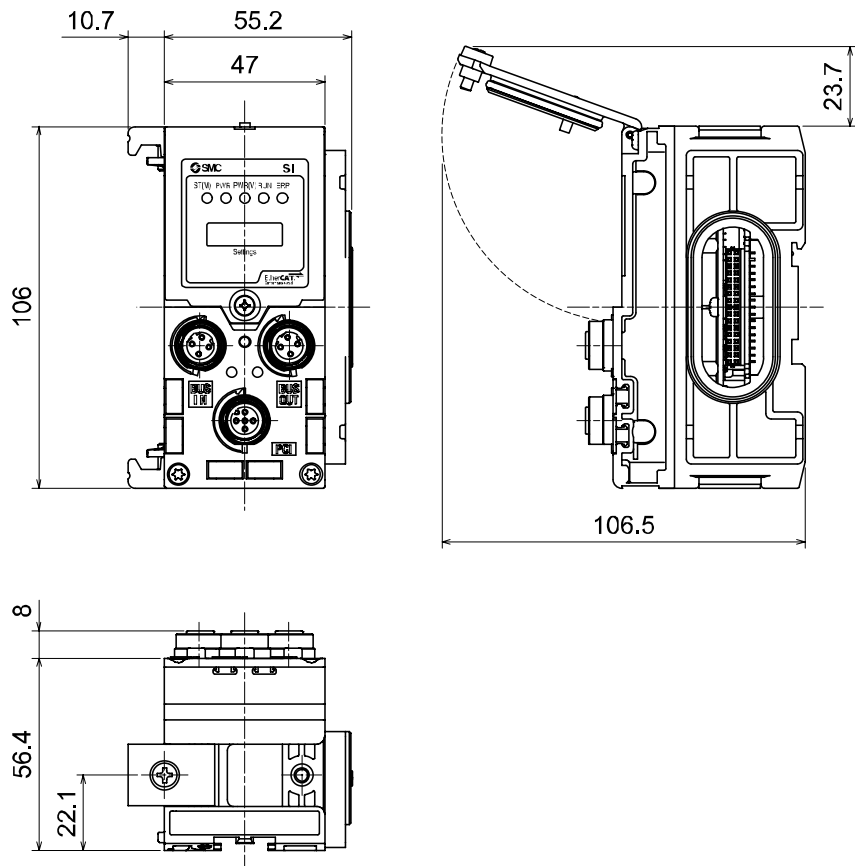

End plate

Model Indication and how to order

EX600-ED□-□

End plate at D side

Mounting method

Connector

Symbol	Content
2	M12 (5 pin)
3	7/8 inch (5 pin)

Symbol	Content
Nil	No DIN rail bracket
2	With DIN rail bracket
3	With DIN rail bracket (Specified for SY series)

Summary of Product parts

•EX600-ED2-□

•EX600-ED3-□

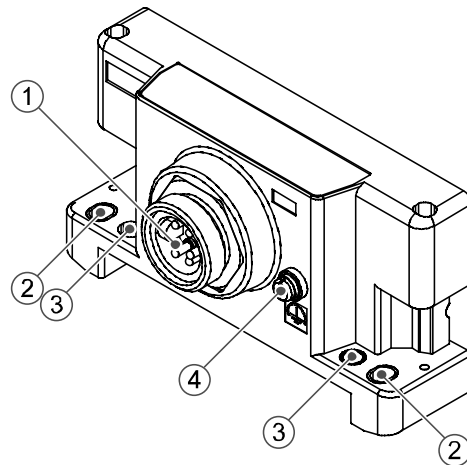
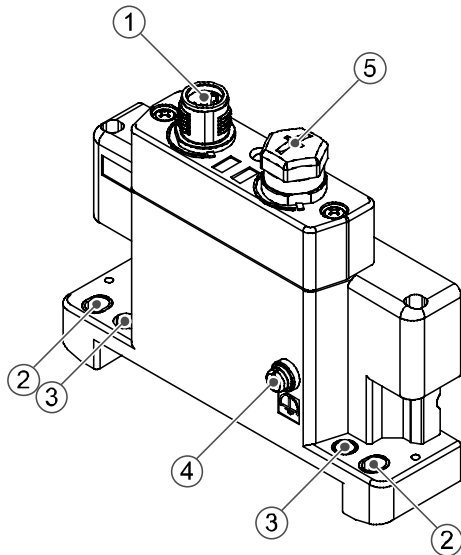

No.	Description	Function
1	Power connector	Connector for power supply to SI unit and I/O unit.
2	Fixing hole for direct mounting	Holes for direct mounting.
3	DIN rail fixing hole	Holes for fix DIN rail mounting.
4	F.E. terminal	Terminal for ground connection.
5	Connector (Not used)	Unused connector. Do not remove seal cap.

Mounting and Installation

■Wiring

○Connector pin assignment

(1)EX600-ED2-□

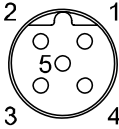
Configuration	Pin No.	Signal name
	1	24 V (Output)
	2	0 V (Output)
	3	24 V (Control and input)
	4	0 V (Control and input)
	5	F.E.

(2)EX600-ED3-□

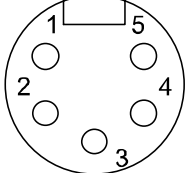
Configuration	Pin No.	Signal name
	1	0 V (Output)
	2	0 V (Control and input)
	3	F.E.
	4	24 V (Control and input)
	5	24 V (Output)

○Regarding the 2 types of power supply

- Power supply for control and input: Supplying power for control of each unit's power supply for control and also for device connected to input port of Digital and Analogue unit.
- Power supply for output: Supplying power for equipment connected to output port of Digital and Analogue unit, and also power supply for solenoid valve manifold.

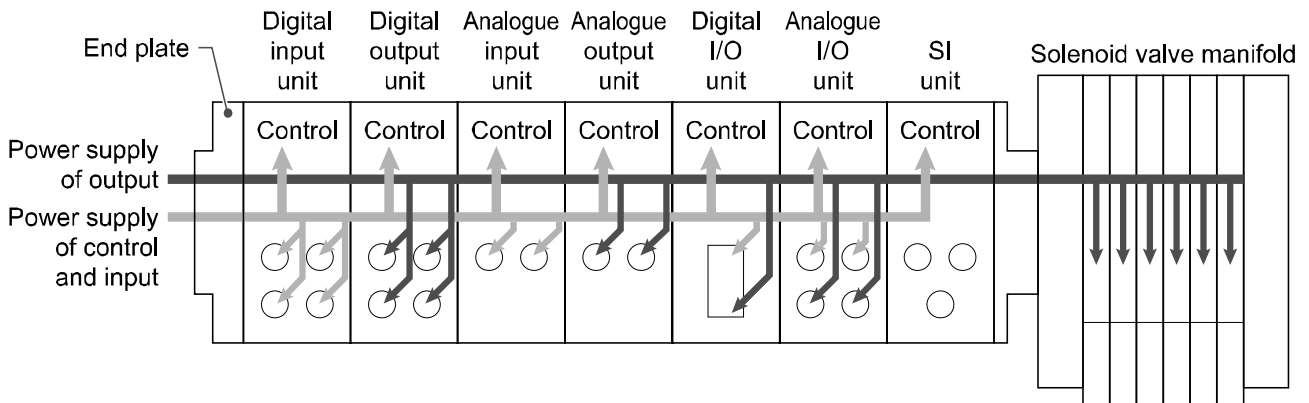

●Precautions for handling

Be sure to fit a seal cap on any unused connectors. Proper use of the seal cap enables the enclosure to achieve IP67 specification.

Specification

■ Specifications

Model		EX600-ED2-□	EX600-ED3-□
Power	Power connector	M12 (5 pin) Plug	7/8 inch (5 pin) Plug
	Power supply (Control and input)	24 VDC ±10% Class2, 2 A	24 VDC ±10%, 8 A
	Power supply (Output)	24 VDC +10/-5% Class2, 2 A	24 VDC +10/-5%, 8 A
Environment	Enclosure	IP67 (With manifold assembled) *1	
	Operating temperature range	-10 to 50 °C (Max. surrounding air temperature rating: 50 °C) *2	
	Storage temperature range	-20 to 60 °C	
	Operating humidity range	35 to 85%R.H. (No condensation)	
	Withstand voltage	500 VAC for 1 minute between external terminals and F.E.	
	Insulation resistance	500 VDC, 10 MΩ min. between external terminals and F.E.	
	Pollution degree	For use in Pollution Degree 3 Environment (UL508)	
Standard		CE, UL(CSA), RoHS	
Weight		170 g	175 g

*1: All unused connectors must have a seal cap fitted.

*2: The UL agreement temperature is 0 to 50 °C.

■ Dimensions (in mm)

• EX600-ED2-□

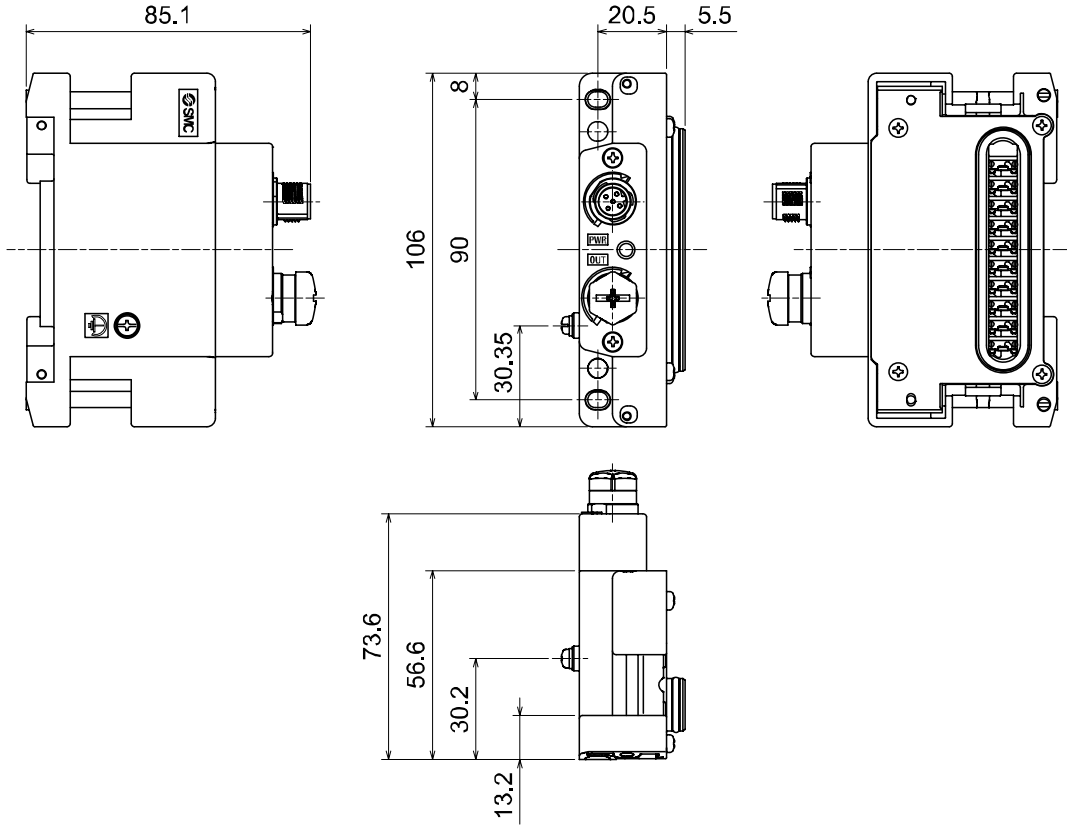

• EX600-ED3-□

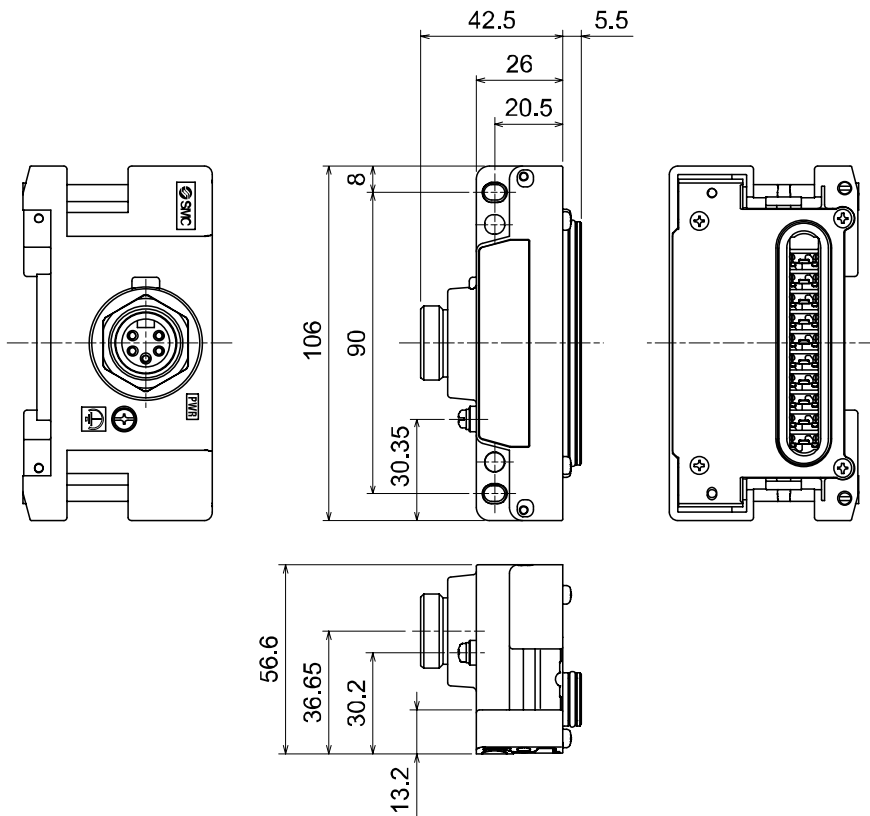

Maintenance

Turn off the power supply, stop the supplied air, exhaust the residual pressure and verify the release of air before performing maintenance.

Cleaning method

Use a soft cloth to remove stains.

For heavy stains, use a cloth soaked with diluted neutral detergent and fully squeezed, then wipe up the stains again with a dry cloth.

Do not use solvents such as benzene, thinner etc. to clean each unit.

Inspection item	Content of inspection
Connector/Electric wiring	Connect properly if the connection is loose.
Seal cap	Tighten properly if the connection is loose.
Thread for mounting and installation	If the thread is loose, re-tighten it to the specified torque.
Connection cables	If the cable is broken or any other abnormality is confirmed by appearance, replace the cable with a new one.
Supply source voltage	Check if source voltage within the specification range (24 VDC \pm 10%) is supplied.

How to reset the product for power cut or forcible de-energizing

Supply power to the product.

The output status just before the power failure is not maintained when power supply is recovered.

Start operation after confirming safety of the entire equipment.

Troubleshooting

•Troubleshooting

When any failure happens with this Fieldbus system, the following chart is used to identify the cause of the failure.

Error status is reflected from the parameter setting of the Fieldbus system.

When a failure occurs, take the appropriate countermeasures referring to the LED display, the troubleshooting and the parameter setting.

If a cause applicable to the failure cannot be identified, it indicates that the Fieldbus system itself is broken. The Fieldbus system breakage can be caused by the operating environment. Contact SMC separately to obtain countermeasures.

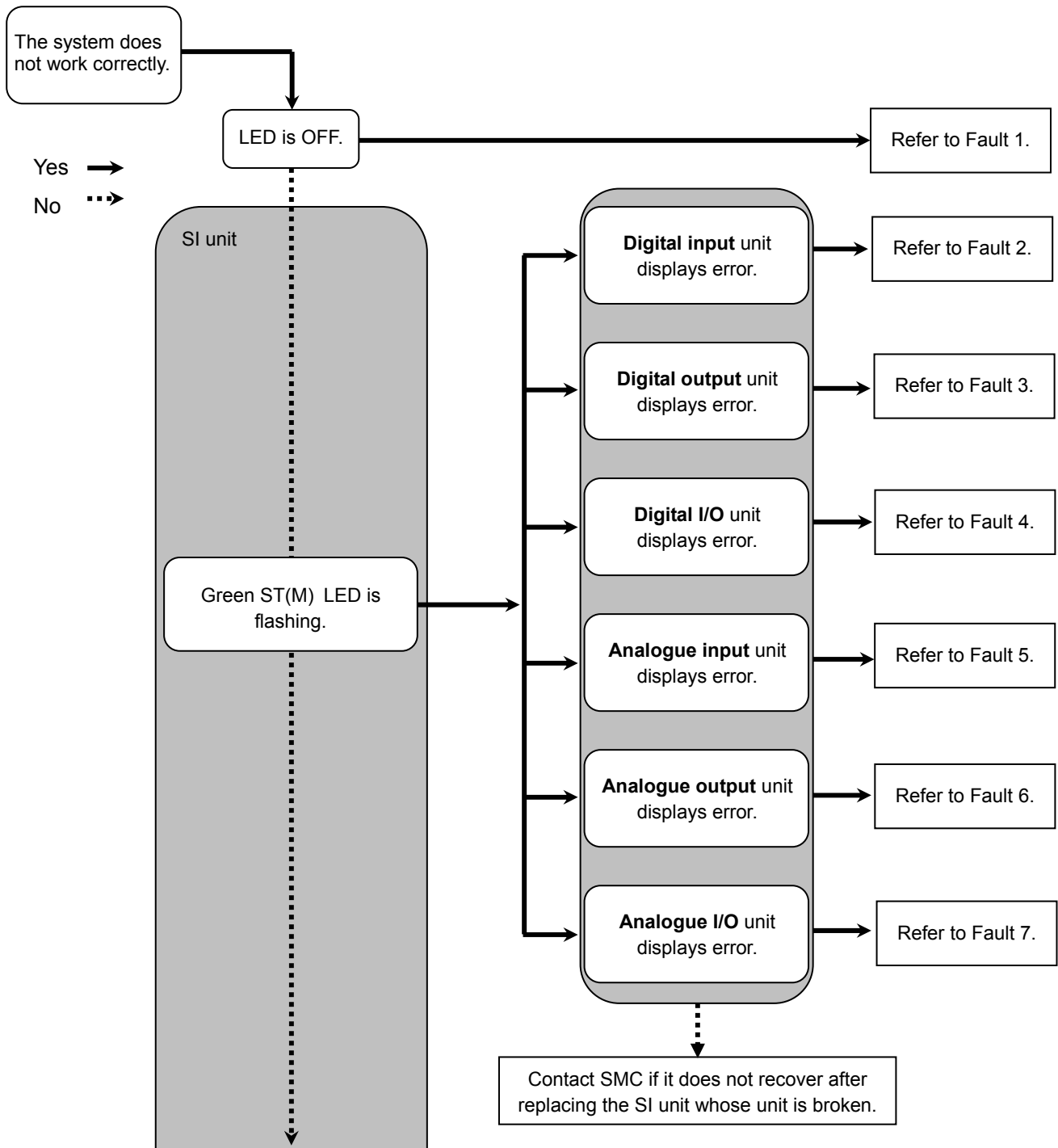

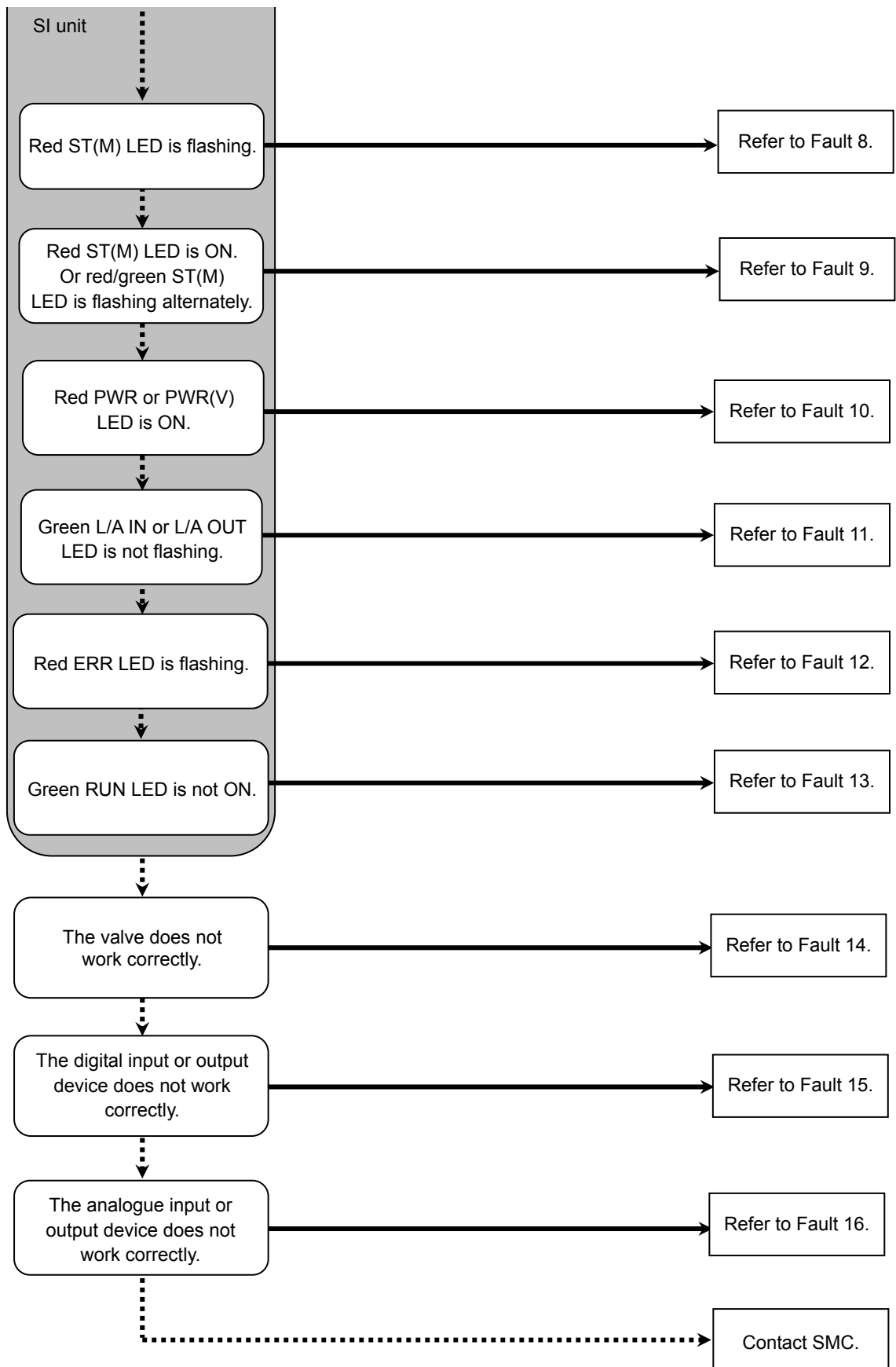

•Trouble counter measure method

No.	Part No. EX600-	Problem	Presumed cause	Troubleshooting
1	-	LED is OFF.	Power supply for control and input is OFF.	Check if the power for control and input is supplied.
2	DX□B DX□C□ DX□D	Red LED is ON. (Diagnosis is activated)	Diagnosis error Input device power supply is short-circuited.	Check the parts with error by using the LED display or master * or H.T. Re-wire the short-circuited part or check if the cable and input device are normal.
		Red LED is flashing. (Diagnosis is activated)	Diagnosis error (1)ON/OFF count of the input device has exceeded the set value. (2)The wire of the input device is broken or disconnected. (Only EX600-DX□C1)	Check the parts with error by using the LED display or master * or H.T. (1)Reset the ON/OFF count to zero or change the set value. Or invalidate diagnosis. (2)Check if the connector is loose and if the wire is broken.
		Red/green all LEDs are flashing.	Unit has failed	Stop the operation and contact SMC.
	DX□E DX□F	Red ST LED is ON. (Diagnosis is activated)	Diagnosis error Input device power supply is short-circuited.	Check the parts with error by using the LED display or master * or H.T. Re-wire the short-circuited part or check if the cable and input device are normal.
		Red ST LED is flashing. (Diagnosis is activated)	Diagnosis error ON/OFF count of the input device has exceeded the set value.	Check the parts with error by using the LED display or master * or H.T. Reset the ON/OFF count to zero or change the set value. Or invalidate diagnosis.
		Red/green ST LED is flashing.	Unit has failed	Stop the operation and contact SMC.

*: Refer to "Diagnostic" (page 63) for details.

No.	Part No. EX600-	Problem	Presumed cause	Troubleshooting
3	DY□B	Red LED is ON. (Diagnosis is activated)	Diagnosis error Output device is short-circuited.	Check the parts with error by using the LED display or master * or H.T. Re-wire the short-circuited part or check if the cable and output device are normal.
		Red LED is flashing. (Diagnosis is activated)	Diagnosis error (1)ON/OFF count of the output device has exceeded the set value. (2)The wire of the output device is broken or disconnected.	Check the parts with error by using the LED display or master * or H.T. (1)Reset the ON/OFF count to zero or change the set value. Or invalidate diagnosis. (2)Check if the connector is loose and if the wire is broken.
		Red/green all LEDs are flashing.	Unit has failed	Stop the operation and contact SMC.
	DY□E DY□F	Red ST LED is ON. (Diagnosis is activated)	Diagnosis error Output device is short-circuited.	Check the parts with error by using the LED display or master * or H.T. Re-wire the short-circuited part or check if the cable and output device are normal.
		Red ST LED is flashing. (Diagnosis is activated)	Diagnosis error (1)ON/OFF count of the output device has exceeded the set value. (2)The wire of the output device is broken or disconnected.	Check the parts with error by using the LED display or master * or H.T. (1)Reset the ON/OFF count to zero or change the set value. Or invalidate diagnosis. (2)Check if the connector is loose and if the wire is broken.
		Red/green ST LED is flashing.	Unit has failed	Stop the operation and contact SMC.
4	DM□E DM□F	Red ST(I) LED is ON. (Diagnosis is activated)	Diagnosis error Input device power supply is short-circuited.	Check the parts with error by using the LED display or master * or H.T. Re-wire the short-circuited part or check if the cable and input device are normal.
		Red ST(I) LED is flashing. (Diagnosis is activated)	Diagnosis error ON/OFF count of the input device has exceeded the set value.	Check the parts with error by using the LED display or master * or H.T. Reset the ON/OFF count to zero or change the set value. Or invalidate diagnosis.
		Red ST(O) LED is ON. (Diagnosis is activated)	Diagnosis error Output device is short-circuited.	Check the parts with error by using the LED display or master * or H.T. Re-wire the short-circuited part or check if the cable and output device are normal.
		Red ST(O) LED is flashing (Diagnosis is activated)	Diagnosis error (1)ON/OFF count of the output device has exceeded the set value. (2)The wire of the output device is broken or disconnected.	Check the parts with error by using the LED display or master * or H.T. (1)Reset the ON/OFF count to zero or change the set value. Or invalidate diagnosis. (2)Check if the connector is loose and if the wire is broken.
		Red/green ST LED is flashing.	Unit has failed	Stop the operation and contact SMC.

*: Refer to "Diagnostic" (page 63) for details.

No.	Part No. EX600-	Problem	Presumed cause	Troubleshooting
5	AXA	Red LED is ON. (Diagnosis is activated)	Diagnosis error Analogue input device power supply is short-circuited.	Check the parts with error by using the LED display or master * or H.T. Re-wire the short-circuited part, and check if the cable and analogue input device are normal.
		"0 and 1" red LEDs are ON.	Input value has exceeded the upper limit when set to current input type range.	Check the following when the range of the Analogue input unit is set to current input. (1)Set the input value of the analogue input device so that it does not exceed the upper limit. (2)Voltage is input from the analogue input device.Ensure the range of the Analogue input unit matches the range of the analogue input device.
		Red LED is flashing. (Diagnosis is activated)	Diagnosis error (1)Input value has exceeded the upper or lower limit of the range. (2)Input value (value set by user) has exceeded the upper or lower limit.	(1)If the input value from the analogue input device exceeds the upper or lower limit of the range, select the appropriate range so that the input value is within the range. Or invalidate diagnosis. (2)If the input value from the analogue input device exceeds the upper or lower limit of the user set value, adjust it so that the input value is within the range of the user set value. Or invalidate diagnosis.
		Red/green all LEDs are flashing.	Unit has failed	Stop the operation and contact SMC.
6	AYA	Red LED is ON. (Diagnosis is activated)	Diagnosis error Analogue output device power supply is short-circuited.	Check the parts with error by using the LED display or master * or H.T. Re-wire the short-circuited part, and check if the cable and analogue output device are normal.
		Red LED is flashing. (Diagnosis is activated)	Diagnosis error Output value (value set by user) has exceeded the upper or lower limit.	If the output value from the analogue output device exceeds the upper or lower limit of the user set value, adjust it so that the output value is within the range of the user set value. Or invalidate diagnosis.
		Red/green all LEDs are flashing.	Unit has failed	Stop the operation and contact SMC.

*: Refer to "Diagnostic" (page 63) for details.

No.	Part No. EX600-	Problem	Presumed cause	Troubleshooting
7	AMB	Red LED is ON. (Diagnosis is activated)	Diagnosis error Analogue input or output device power supply is short-circuited.	Check the parts with error by using the LED display or master * or H.T. Re-wire the short-circuited part, and check if the cable and analogue input or output device are normal.
		"0 and 1" red LEDs are ON.	Input value has exceeded the upper limit when set to current input type range.	Check the following when the range of the Analogue input unit is set to current input. (1)Set the input value of the analogue input device so that it does not exceed the upper limit. (2)Voltage is input from the analogue input device. Ensure the range of the input unit matches the range of the input device.
		Red LED is flashing. (Diagnosis is activated)	Diagnosis error (1)Input value has exceeded the upper or lower limit of the range. (2)Input or output value (value set by user) has exceeded the upper or lower limit.	(1)If the input value from the analogue input device exceeds the upper or lower limit of the range, select the appropriate range so that the input value is within the range. Or invalidate diagnosis. (2)If the input (output) value from the analogue input (output) device exceeds the upper or lower limit of the user set value, adjust it so that the input (output) value is within the range of the user set value. Or invalidate diagnosis.
		Red/green all LEDs are flashing.	Unit has failed	Stop the operation and contact SMC.
8		Red ST(M) LED is flashing. (Diagnosis is activated)	Diagnosis error (SI unit) (1)Valve is short-circuited. (2)Valve is open-circuited. (3)ON/OFF count of the valve has exceeded the set value.	Check the parts with error by using the LED display or master * or H.T. (1)Check the operation after replacing the valve. (2)Check the operation after replacing the valve. (3)Reset the ON/OFF count to zero or change the set value. Or invalidate diagnosis.
9		Red ST(M) LED is ON.	SI unit has failed.	Stop the operation and contact SMC.
		Red/green ST(M) LED is flashing alternately.	(1)Connection between the units is defective. (2)Configuration memory error.	(1)Confirm that there is no loose connection between the units and connect them correctly. (2)Unit layout is not the same as the unit layout when it was memorized. Return the layout to the same as when it was memorized, or update the configuration memory, or turn off the configuration memory function.
10		Red PWR LED is ON. (Diagnosis is activated)	Power supply voltage for control and input is abnormal.	Supply 24 VDC \pm 10% for control and input power source.
		Red PWR(V) LED is ON. (Diagnosis is activated)	Power supply voltage for output is abnormal.	Supply 24 VDC +10/-5% for output power source.

*: Refer to "Diagnostic" (page 63) for details.

No.	Problem	Presumed cause	Troubleshooting
11	L/A IN and L/A OUT LEDs are OFF.	LINK has not yet been established.	<p>Check the following and restart.</p> <p>(1)Check if the power is supplied to the EtherCAT device one level above. (When L/A IN LED is OFF.)</p> <p>(2)Check that the connectors of L/A IN and L/A OUT communication cables are connected and there are no broken wires.</p> <p>(3)Keep noise sources away from the communication cable.</p> <p>*: The L/A OUT LED will be OFF if the BUS OUT connector is not used.</p>
	L/A IN and L/A OUT Green LED is ON.	LINK is established but data has not been received.	<p>Check the following and restart.</p> <p>(1)Check the master condition and run the master.</p> <p>(2)Check whether the L/A LEDs of the EtherCAT devices two or more levels above are off. If so, please check if the power is supplied.</p> <p>(3)Check that the communication connector is not loose and there are no broken wires.</p> <p>(4)Keep noise sources away from the communication cable.</p>
12	ERR LED is Double flashing. *	Communication error (Application watchdog timeout)	<p>Check the following and restart.</p> <p>(1)Check the master condition and run the master.</p> <p>(2)Check if the power is supplied to the EtherCAT device.</p> <p>(3)Check that the communication connector is not loose and there are no broken wires.</p>
	ERR LED is flashing. *	Communication setup error	Check the master configuration and the system structure.
13	RUN LED is OFF.	SI unit is initialized.	Download an appropriate XML file from SMC website and perform configuration.
	RUN LED is flashing. *	Pre-operational status	Check the master condition and RUN the master.
	RUN LED is single flashing. *	Safe operational status	Check the master condition and RUN the master.

*: Refer to page 21 "LED display" for details of LED status.

No.	Problem	Presumed cause	Troubleshooting
14	Abnormal valve operation	The number of connected valves is larger than the number of occupied valve outputs.	When the number of occupied valves of the V_SEL switch is smaller than the number of connected valves, set the switch so that the number of occupied valves is not smaller than the number of valves to be used.
		Abnormality with program, etc.	Check if the ladder program of master, etc. is correct.
		Abnormal power supply for output.	Check if the green PWR(V) LED of the SI unit is ON. If the LED is off, or the red LED is ON, supply 24 VDC +10/-5% to the power supply for output.
		Connection between SI unit and manifold valve is defective.	Check the connectors between the SI unit and manifold valve are not damaged, such as bent pins, and connect them correctly.
		Polarity of output does not match.	IF the polarity of the SI unit and the valve are different, replace one of them to make the combination match. <ul style="list-style-type: none"> •EX600-SEC1 (PNP output) ⇒ -common type valve •EX600-SEC2 (NPN output) ⇒ +common type valve
		SI unit has failed.	Replace the SI unit with a normal one, and check the operation.
	Valve failure.	Replace the valve with a normal one, and check the operation. Or refer to the troubleshooting of the valve used.	

No.	Problem	Presumed cause	Troubleshooting
15	Abnormal digital input device operation	Polarity of input does not match.	If the polarity (PNP, NPN) of the input unit and the input device are different, replace one of them to make the combination match.
		Power supply for control and input is abnormal.	Check if the green PWR LED of the SI unit is ON. If the LED is off, or the red LED is ON, supply 24 VDC $\pm 10\%$ to the power supply for control and input.
		Wiring or connection is defective.	Connect the wiring correctly between the digital input device and the Digital input unit.
		Input unit has failed.	Replace the input unit with a normal one, and check the operation.
		Input device failure.	Replace the input device with a normal one, and check the operation. Or refer to the troubleshooting of the input device used.
	Abnormal digital output device operation	Polarity of output does not match.	If the polarity (PNP, NPN) of the output unit and the output device are different, replace one of them to make the combination match.
		Power supply for output is abnormal.	Check if the green PWR(V) LED of the SI unit is ON. If the LED is off, or the red LED is ON, supply 24 VDC $+10/-5\%$ to the power supply for output.
		Wiring or connection is defective.	Connect the wiring correctly between the digital output device and the Digital output unit.
		Output unit has failed.	Replace the Output unit with a normal one, and check the operation.
		Output device failure.	Replace the output device with a normal one, and check the operation. Or refer to the troubleshooting of the output device used.
		Program etc. is defective.	Check if the ladder program of master, etc. is correct.

No.	Problem	Presumed cause	Troubleshooting
16	Abnormal analogue input device operation	Power supply for control and input is abnormal.	Check if the green PWR LED of the SI unit is ON. If the LED is off, or the red LED is ON, supply 24 VDC $\pm 10\%$ to the power supply for control and input.
		Analogue input signal range setting failure.	Check the analogue input device specification, and set the input signal range which satisfies the specification.
		Analogue data format does not match.	Check whether the data format of the Analogue input unit is properly set.
		Wiring or connection is defective.	Connect the wiring correctly between the analogue input device and the Analogue input unit.
		Analogue input unit has failed.	Replace the Analogue input unit with a normal one, and check the operation.
		Analogue input device failure.	Replace the analogue input device with a normal one, and check the operation. Or refer to the troubleshooting of the analogue input device used.
	Abnormal analogue output device operation	Power supply for output is abnormal.	Check if the green PWR(V) LED of the SI unit is ON. If the LED is off, or the red LED is ON, supply 24 VDC $+10/-5\%$ to the power supply for output.
		Analogue output signal range setting failure.	Check the analogue output device specification, and set the output signal range which satisfies the specification.
		Analogue data format does not match.	Check whether the data format of the Analogue output unit is properly set.
		Wiring or connection is defective.	Connect the wiring correctly between the analogue output device and the Analogue output unit.
		Analogue output unit has failed.	Replace the Analogue output unit with a normal one, and check the operation.
		Analogue output device failure.	Replace the analogue output device with a normal one, and check the operation. Or refer to the troubleshooting of the analogue output device used.
		Program etc. is defective.	Check if the ladder program of master, etc. is correct.

Parameter Setting

The product has parameters that can be set for the system, each unit or each channel.

The parameters can be changed using the PLC and handheld terminal.

There is no order of precedence of the PLC and handheld terminal. The latest parameter settings are used.

- Precautions for handling

- Changing parameters with the H.T. does not change the parameter settings in the PLC.
- If parameters are downloaded from the configuration to the PLC after changing parameters with the H.T., parameters will be changed to those which are set by the configuration. Therefore, set parameters by PLC if the parameters can be changed by both PLC and H.T.
- The H.T. have to use EX600-HT1A. (EX600-HT1 cannot be used.)

■ Parameter definition and setting

- System parameters

No.	Parameter (H.T. Symbol)	Definition	Item	Content	Default setting	Parameter setting	
						By Ether CAT	By H.T.
1	Hold/Clear priority setting (Hold/Clear)	Switch the setting of the output during communication error or communication idling to follow the setting of the SI unit or the parameters.	Switch	Setting by SI unit switch becomes valid. OFF/Hold/Forced ON can be set per channel	○		
			Handheld	Setting by parameters or the H.T. becomes valid. OFF/Hold/Forced ON can be set per channel.		○	○

•SI unit parameters (1)

No.	Parameter (H.T. Symbol)	Definition	Item	Content	Default setting	Parameter setting	
						By Ether CAT	By H.T.
1	Power supply for control and input voltage monitor (PWRC_Mon)	Generated error when control and input power supply voltage goes over approx. 26 V or under 21 V.	Enable	Generates an error.	○	○	○
			Disable	Does not generate an error.			
2	Power supply for output voltage monitor (PWRO_Mon)	Generated error when output power supply voltage goes over approx. 26 V or under 20 V.	Enable	Generates an error.	○	○	○
			Disable	Does not generate an error.			
3	Short Circuit Detection (SC_MonOp)	Generates error when the short circuit of the valve is detected.	Enable	Generates an error.	○	○	○
			Disable	Does not generate an error.			
4	Restart after short circuit (SC_RstOp)	Restore the setting of short circuit detection error after the valve short circuit is cleared.	Auto	Error is automatically cleared when the short circuit is fixed.	○	○	○
			Manual	Even when the short circuit is fixed, error is not cleared until the power is supplied again.			
5	Open Circuit Detection (OC_Mon)	Generates error per channel when the disconnection of the valve is detected.	Enable	Generates an error.		○	○
			Disable	Does not generate an error.	○		
6	Output setting during communication fault *1 (Fault_MD)	Set output per channel when communication is abnormal.	Clear	Turn off the output	○	○	○
			Hold	Hold the output			
			ForceON	Turn on the output forcefully			
7	Output setting during communication idling *1 (Idle_MD)	Output setting per channel at the time of communication idling	Clear	Turn off the output	○	○	○
			Hold	Hold the output			
			ForceON	Turn on the output forcefully			

•SI unit parameters (2)

No.	Parameter (H.T. Symbol)	Definition	Item	Content	Default setting	Parameter setting	
						By Ether CAT	By H.T.
8	Valve ON/OFF counter (Counter)	Memorizes the number of times the valve is ON. Generates error per channel when the operation count exceeds the set value. *2	Enable	Generates an error. Val: 1 to 65000 *3			
			Disable	Does not generate an error.	○	○	○

*1: This master is valid only when "Hold/Clear priority" of the system parameter is set to Handheld.

*2: The count is memorized every 30 seconds per channel. When the power supply is turned on again, counting starts from the last value memorized.

*3: Times for setting is set value x1000 times.

•Digital input unit parameters

No.	Parameter (H.T. Symbol)	Definition	Item	Content	Default setting	Parameter setting	
						By Ether CAT	By H.T.
1	The power supply short circuit detection for control and input (SC_MonSs)	Generates error per unit when the short circuit of the power supply for the input device is detected.	Enable	Generates an error.	○		
			Disable	Does not generate an error.		○	○
2	Open circuit detection *1 (OC_Mon)	Generates error per channel when the disconnection of the input device is detected. *2	Enable	Generates an error.		○	○
			Disable	Does not generate an error.	○		
3	Inrush current filter (Inrush)	Ignores excess current per unit for 100 msec. after inrush.	Enable	Ignores excess current.		○	○
			Disable	Does not ignore excess current.	○		
4	Input filtering time (Filter_T)	Sets the time to ignore the input signal change per unit.	0.1 ms	Selects the time for filtering.	1.0 ms	○	○
			1.0 ms				
			10 ms				
			20 ms				
5	Input extension time (SigExt_T)	Sets the time to hold the input signal per unit.	1.0ms	Selects the time to hold the input signal.	15 ms	○	○
			15 ms				
			100 ms				
			200 ms				
6	Channel ON/OFF counter (Counter)	Memorizes the number of times the input device is ON. Generates error per channel when the operation count exceeds the set value. *3	Enable	Generates an error. Val: 1 to 65000 *4		○	○
			Disable	Does not generate an error.	○		

*1: Disconnection detection is a parameter only available for Digital unit (EX600-DXPC1, EX600-DXNC1) with disconnection detection.

*2: 2-wire type input equipment cannot be correctly detected if its leakage current is 0.5 mA or less while the equipment is in the OFF state (reed sensor, etc.).

Ensure that all input equipment used has a leakage current above 0.5 mA in the OFF state.

3-wire type input equipment cannot be correctly detected if its current consumption is 0.5mA or less.

The open circuit of input signals cannot be detected.

*3: The count is memorized every hour. When the power supply is turned on again, counting starts from the last value memorized.

*4: Times for setting is set value x1000 times.

•Digital output unit parameters

No.	Parameter (H.T. Symbol)	Definition	Item	Content	Default setting	Parameter setting	
						By Ether CAT	By H.T.
1	Output load short circuit detection (SC_MonOp)	Generates error per unit when the short circuit of the output device is detected. *1	Enable	Generates an error.	○	○	○
			Disable	Does not generate an error.			
2	Restart after output load short circuit (SC_RstOp)	Restore the setting of short circuit detection error per unit after the output device short circuit is cleared.	Auto	Error is automatically cleared when the short circuit is fixed.	○	○	○
			Manual	Even when the short circuit is fixed, error is not cleared until the power is supplied again.			
3	Open circuit detection (OC_Mon)	Generates error per channel when the disconnection of the output device is detected.	Enable	Generates an error.		○	○
			Disable	Does not generate an error.	○		
4	Output setting during communication fault *2 (Fault_MD)	Set output per channel when communication is abnormal.	Clear	Turn off the output	○	○	○
			Hold	Hold the output			
			ForceON	Turn on the output forcefully			
5	Output setting during communication idling *2 (Idle_MD)	Set output per channel during communication idling.	Clear	Turn off the output	○	○	○
			Hold	Hold the output			
			ForceON	Turn on the output forcefully			
6	Output ON/OFF counter (Counter)	Memorizes the number of times the output device is ON. Generates error per channel when the operation count exceeds the set value. *3	Enable	Generates an error. Val: 1 to 65000 *4		○	○
			Disable	Does not generate an error.	○		

*1: Could be incorrectly recognized as short circuit depending on used load (ex.: lamp load). If detection is incorrect, disable the parameter setting.

*2: This master is valid only when "Hold/Clear priority" of the system parameter is set to Handheld.

*3: The count is memorized every hour. When the power supply is turned on again, counting starts from the last value memorized.

*4: Times for setting is set value x1000 times.

•Digital I/O unit parameters (1)

No.	Parameter (H.T. Symbol)	Definition	Item	Content	Default setting	Parameter setting	
						By Ether CAT	By H.T.
1	The power supply short circuit detection for control and input (SC_MonSs)	Generates error per unit when the short circuit of the control or input power supply is detected.	Enable	Generates an error.	○	○	○
			Disable	Does not generate an error.			
2	Inrush current filter (Inrush)	Ignores excess current per unit for 100 msec. after inrush.	Enable	Ignores excess current.		○	○
			Disable	Does not ignore excess current	○		
3	Input filtering time (Filter_T)	Sets the time to ignore the input signal change per unit	0.1 ms	Selects the time for filtering.	1.0 ms	○	○
			1.0 ms				
			10 ms				
			20 ms				
4	Input extension time (SigExt_T)	Sets the time to hold the input signal per unit.	1.0 ms	Selects the time to hold the input signal.	15 ms	○	○
			15 ms				
			100 ms				
			200 ms				
5	Output load short circuit detection (SC_MonOp)	Generates error per unit when the short circuit of the output device is detected. *1	Enable	Generates an error.	○	○	○
			Disable	Does not generate an error.			
6	Restart after output load short circuit (SC_RstOp)	Restore the setting of short circuit detection error per unit after the output device short circuit is cleared.	Auto	Error is automatically cleared when the short circuit is fixed.	○	○	○
			Manual	Even when the short circuit is fixed, error is not cleared until the power is supplied again.			
7	Open circuit detection (OC_Mon)	Generates error per channel when the disconnection of the output device is detected.	Enable	Generates an error.		○	○
			Disable	Does not generate an error.	○		
8	Output setting during communication fault *2 (Fault_MD)	Set output per channel when communication is abnormal.	Clear	Turn off the output	○	○	○
			Hold	Hold the output			
			ForceON	Turn on the output forcefully			

•Digital I/O unit parameters (2)

No.	Parameter (H.T. Symbol)	Definition	Item	Content	Default setting	Parameter setting	
						By Ether CAT	By H.T.
9	Output setting for communication idling ^{*2} (Idle_MD)	Set output per channel during communication idling.	Clear	Turn off the output	○		
			Hold	Hold the output		○	○
			ForceON	Turn on the output forcefully			
10	Input or Output ON/OFF counter (Counter)	Memorizes the number of times the input or output device is ON. Generates error per channel when the operation count exceeds the set value. ^{*3}	Enable	Generates an error. Val: 1 to 65000 ^{*4}		○	○
			Disable	Does not generate an error.	○		

*1: Could be incorrectly recognized as short circuit depending on used load (ex.: lamp load). If detection is incorrect, disable the parameter setting.

*2: This master is valid only when "Hold/Clear priority" of the system parameter is set to Handheld.

*3: The count is memorized every hour. When the power supply is turned on again, counting starts from the last value memorized.

*4: Times for setting is set value x1000 times.

•Analogue input unit parameters

No.	Parameter (H.T. Symbol)	Definition	Item	Content	Default setting	Parameter setting	
						By Ether CAT	By H.T.
1	The power supply short circuit detection for the input device (SC_MonSs)	Generates error per unit when the short circuit of the power supply for the input device is detected.	Enable	Generates an error.	<input type="radio"/>	<input type="radio"/>	<input type="radio"/>
			Disable	Does not generate an error.		<input type="radio"/>	<input type="radio"/>
2	Analogue input range (Range)	Set the analogue input device range per channel.	-10..10 V	Selects the analogue input range.	-10..10 V	<input type="radio"/>	<input type="radio"/>
			-5..5 V				
			-20..20 mA				
			0..10 V				
			0..5 V				
			1..5 V				
			0..20 mA				
4..20 mA							
3	Analogue data format (D_Format)	Sets analogue data type which is output to master per unit.	Offset binary	Offset binary.	<input type="radio"/>	<input type="radio"/>	<input type="radio"/>
			Sign & Magnitude	Signed binary.		<input type="radio"/>	<input type="radio"/>
			2's complement	2's complement.			
4	Analogue average filter (Filter)	Sets analogue filtering time per channel. Sampling interval is approx. 2 sec.	None	None		<input type="radio"/>	<input type="radio"/>
			2AVG	2 value average	<input type="radio"/>		<input type="radio"/>
			4AVG	4 value average		<input type="radio"/>	<input type="radio"/>
			8AVG	8 value average			
5	Over range detection (Over_Rng)	Generates error per unit when the input value exceeds 0.5% of full span.	Enable	Generates an error.	<input type="radio"/>	<input type="radio"/>	<input type="radio"/>
			Disable	Does not generate an error.		<input type="radio"/>	<input type="radio"/>
6	Under range detection (Undr_Rng)	Generates error per unit when the input value falls below 0.5% of full span.	Enable	Generates an error.	<input type="radio"/>	<input type="radio"/>	<input type="radio"/>
			Disable	Does not generate an error.		<input type="radio"/>	<input type="radio"/>
7	User setting value upper limit error (Upr_Lmt)	Generates error per unit when the input value exceeds the set value.	Enable	Generates an error. *1		<input type="radio"/>	<input type="radio"/>
			Disable	Does not generate an error.	<input type="radio"/>		<input type="radio"/>
8	User setting value lower limit error (Lwr_Lmt)	Generates error per channel when the input value falls below the set value.	Enable	Generates an error. *1		<input type="radio"/>	<input type="radio"/>
			Disable	Does not generate an error.	<input type="radio"/>		<input type="radio"/>

*1: Set value shall be set per analogue input range within settable range on the following page. When the analogue input range is changed, check the set value and change it to an appropriate value.

For settings via EtherCAT, make sure to set the upper limit set value larger than the lower limit set value, as the setting is otherwise invalid, although the setting may be set to "valid".

Analogue input measurement range (Range)	Upper and lower setting limit of user setting	
	(Lwr_Lmt)	(Upr_Lmt)
-10..10 V	-10.50 to +10.45 V	-10.45 to +10.50 V
-5..5 V	- 5.25 to + 5.22 V	- 5.22 to +5.25 V
-20..20 mA	-21.00 to +20.90 mA	-20.90 to +21.00 mA
0..10 V	0.00 to +10.45 V	+0.05 to +10.50 V
0..5 V	0.00 to +5.22 V	+0.03 to +5.25 V
1..5 V	+0.75 to +5.22 V	+0.78 to +5.25 V
0..20 mA	0.00 to +20.90 mA	+0.10 to +21.00 mA
4..20 mA	+3.00 to +20.90 mA	+3.10 to +21.00 mA

•Analogue output unit parameters (1)

No.	Parameter (H.T. Symbol)	Definition	Item	Content	Default setting	Parameter setting	
						By Ether CAT	By H.T.
1	The power supply short circuit detection for the output device (SC_MonSs)	Generates error per unit when the short circuit of the output device is detected.	Enable	Generates an error.	○	○	○
			Disable	Does not generate an error.			
2	Analogue output range (Range)	Sets the range of the analogue output device per channel.	0..10 V	Selects the analogue output range.	0..10 V	○	○
			0..5 V				
			1..5 V				
			0..20 mA				
3	Analogue data format (D_Format)	Sets analogue data type which is output to master per unit.	Offset binary	Offset binary.	○	○	○
			Sign & Magnitude	Signed binary.			
			2's Complement	2's complement.			
			Scaled	Scale conversion type.			
4	User setting value upper limit error (Upr_Lmt)	Generates error per channel when the output value exceeds the set value.	Enable	Generates an error. *2 *3		○	○
			Disable	Does not generate an error.	○		
	Scale upper limit setting *1 (UpLm/ScI)	Sets the scale upper limit. Generates error per channel when the output value exceeds the upper limit.	Enable	Generates an error. *3 Val: -32766 to 32767			
			Disable	Does not generate an error. *3 Val: -32766 to 32767	○ Val: 1000		
5	User setting value lower limit error (Lwr_Lmt)	Generates error per channel when the output value exceeds the set value.	Enable	Generates an error. *2 *3		○	○
			Disable	Does not generate an error.	○		
	Scale lower limit setting *1 (LwLm/ScI)	Sets the scale lower limit. Generates error per channel when the output value falls below the lower limit.	Enable	Generates an error. *3 Val: -32767 to 32766			
			Disable	Does not generate an error. *3 Val: -32767 to 32766	○ Val: 0		
6	Output setting for communication error *3 (Fault_MA)	Set output per channel when communication is abnormal.	Enable	Output will be user fault value. *2		○	○
			Disable	Output will be held last state.	○		

•Analogue output unit parameters (2)

No.	Parameter (H.T. Symbol)	Definition	Item	Content	Default setting	Parameter setting	
						By Ether CAT	By H.T.
7	Output setting for communication idling *4 (Idle_MA)	Set output per channel during communication idling.	Enable	Output will be user idle value. *2			
			Disable	Output will be held last state.	○	○	○

*1: When "Scaled" is selected as the analogue data format, the display of H.T. is switched from Upr_Lmt to UpLm/ScI, from Lwr_Lmt to LwLm/ScI.

*2: Set value shall be set per analogue input range within settable range in the table below.

When the analogue input range is changed, check the set value and change it to an appropriate value.

*3: For settings of the user upper/lower limit or scale upper/lower limit via EtherCAT, make sure to set the upper limit set value larger than the lower limit set value, as the setting is actually invalid if it is set with the upper limit set value is smaller than the lower limit set value, although the setting in such condition is be set to be "valid".

*4: This master is valid only when "Hold/Clear priority" of the system parameter is set to Handheld.

Analogue output measurement range (Range)	Upper and lower setting limit of user setting		Settable range during communication error or idling (Fault_MA) (Idle_MA)
	(Lwr_Lmt)	(Upr_Lmt)	
0..10 V	0.00 to +10.45 V	+0.05 to +10.50 V	0.00 to +10.50 V
0..5 V	0.00 to + 5.22 V	+0.03 to +5.25 V	0.00 to +5.25 V
1..5 V	+0.75 to +5.22 V	+0.78 to +5.25 V	+0.75 to +5.25 V
0..20 mA	0.00 to +20.90 mA	+0.10 to +21.00 mA	0.00 to +21.00 mA
4..20 mA	+3.00 to +20.90 mA	+3.10 to +21.00 mA	+3.00 to +21.00 mA

•Analogue I/O unit parameters (1)

No.	Parameter (H.T. Symbol)	Definition	Item	Content	Default setting	Parameter setting	
						By Ether CAT	By H.T.
1	The power supply short circuit detection for the input or output device (SC_MonSs)	Generates error per unit when the short circuit of the input device power supply or output device is detected.	Enable	Generates an error.	○	○	○
			Disable	Does not generate an error.			
2	Analogue input or output range (Range)	Sets the analogue input or output device range per channel.	0..10 V	Selects the analogue input or output range	1..5 V	○	○
			0..5 V				
			1..5 V				
			0..20 mA				
			4..20 mA				
3	Analogue data format (D_Format)	Sets analogue data type which is output to master per unit.	Offset binary	Offset binary.	○	○	○
			Sign & Magnitude	Signed binary.			
			2s complement	2's complement.			
			Scaled	Scale conversion type.			
4	Analogue average filter (Filter)	Sets analogue filtering time per channel. Sampling interval is approx. 2 sec.	None	None		○	○
			2AVG	2 value average	○		
			4AVG	4 value average			
			8AVG	8 value average			
5	Over range detection (Over_Rng)	Generates error per unit when the input value exceeds 0.5% of full span.	Enable	Generates an error.		○	○
			Disable	Does not generate an error.	○		
6	Under range detection (Undr_Rng)	Generates error per unit when the input value falls below 0.5% of full span.	Enable	Generates an error.		○	○
			Disable	Does not generate an error.	○		
7	User's set value upper limit error (Upr_Lmt)	Generates error per channel when the input or output value exceeds the set value.	Enable	Generates an error. *2 *3		○	○
			Disable	Does not generate an error.	○		
	Scale upper limit setting *1 (UpLm/Scl)	Sets the scale upper limit. Generates error per channel when the input or output value exceeds the upper limit.	Enable	Generates an error. *3 Val: -32766 to 32767			
			Disable	Does not generated an error. *3 Val: -32766 to 32767	○ Val: 1000		

•Analogue I/O unit parameters (2)

No.	Parameter (H.T. Symbol)	Definition	Item	Content	Default setting	Parameter setting	
						By Ether CAT	By H.T.
8	User's set value lower limit error (Lwr_Lmt)	Generates error per channel when the input or output value falls below the lower limit.	Enable	Generates an error. *2			
			Disable	Does not generate an error.	○		
	Scale lower limit setting *1 (UpLm/ScI)	Sets the scale lower limit. Generates error per channel when the input or output value falls below the lower limit.	Enable	Generates an error. *3 Val: -32767 to 32766		○	○
			Disable	Does not generate an error. *3 Val: -32767 to 32766	○ Val: 0		
9	Output setting for communication fault *3 (Fault_MA)	Set output per channel when communication is abnormal.	Enable	Output will be user fault value. *2		○	○
			Disable	Output will be held last state.	○		
10	Output setting for communication idling *4 (Idle_MA)	Sets output per channel during communication idling.	Enable	Output will be user idle value. *2		○	○
			Disable	Output will be held last state.	○		

*1: When "Scaled" is selected as the analogue data format, the display of H.T. is switched from Upr_Lmt to UpLm/ScI, from Lwr_Lmt to LwLm/ScI.

*2: Set value shall be set per analogue output range within settable range in the table below.

When the analogue output range is changed, check the set value and change it to an appropriate value.

*3: For settings of the user upper/lower limit or scale upper/lower limit via EtherCAT, make sure to set the upper limit set value larger than the lower limit set value, as the setting is, although the setting may be set to "valid".

*4: This master is valid only when "Hold/Clear priority" of the system parameter is set to Handheld.

Analogue Input or output measurement range (Range)	Upper and lower setting limit of user setting		Settable range during communication error or idling (Fault_MA) (Idle_MA)
	(Lwr_Lmt)	(Upr_Lmt)	
0..10 V	0.00 to +10.45 V	+0.05 to +10.50 V	0.00 to +10.50 V
0..5 V	0.00 to +5.22 V	+0.03 to +5.25 V	0.00 to +5.25 V
1..5 V	+0.75 to +5.22 V	+0.78 to +5.25 V	+0.75 to +5.25 V
0..20 mA	0.00 to +20.90 mA	+0.10 to +21.00 mA	0.00 to +21.00 mA
4..20 mA	+3.00 to +20.90 mA	+3.10 to +21.00 mA	+3.00 to +21.00 mA

Hardware Configuration

The address is automatically recognized and allocated to the EtherCAT product during configuration.
(There is no need for the user to set an address)
Make sure to use the XML file for EX600 to perform configuration.

■ XML file

The XML file is required to configure the EX600.
The file can be downloaded from the SMC website.
•URL:<http://www.smcworld.com>
Product Document → Instruction Manual

■ Setting using TwinCAT[®] System Manager

The following describes how to connect the EX600 to a PC with TwinCAT[®] System Manager installed.
Refer to the manual of TwinCAT[®] System Manager for details of the operating method.

•XML file installation

(1) Copy the XML file for the EX600 to the following folder.

C:\TwinCAT\IO\EtherCAT

(*: This path is valid only when the folder for TwinCAT[®] System Manager is installed in the default folder location.)

(2) Start up the TwinCAT[®] System Manager.

•Registration to the network

When registering the EX600 on the network, there are two methods available, as follows.

- On-line Auto Configuration
- Off-line Manual Configuration

- On-line Auto Configuration

- Connect the EX600 unit to the network and supply the power.
- Right click the [I/O Devices] file, and then left click the [Scan Devices] file from the pop up menu.

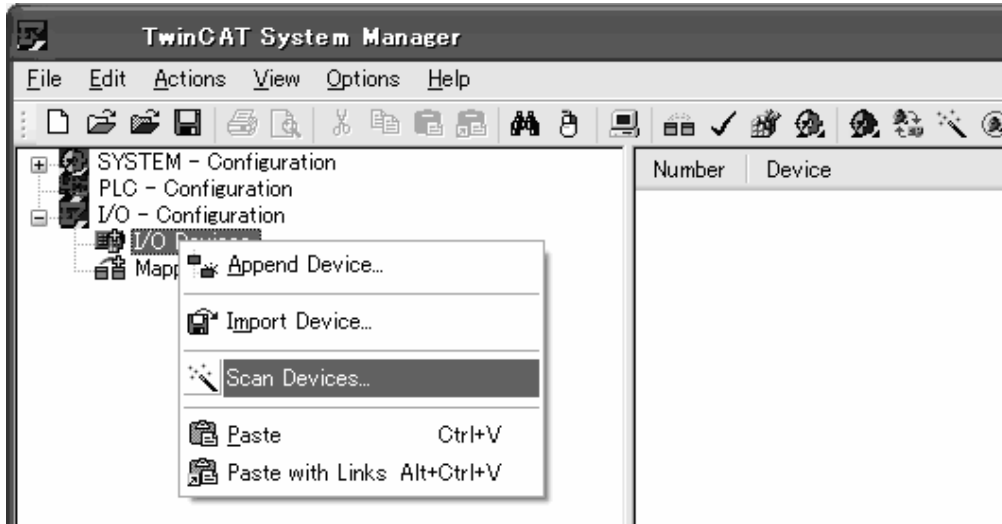

- When the comment "Scan for boxes" appears, left click the [YES(Y)] button.

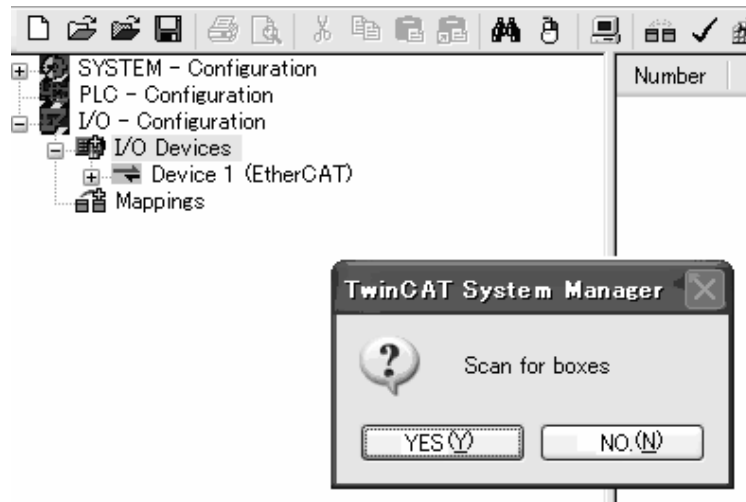

- Once the scan is successfully completed, [Box 1(EX600-SEC*)] is displayed as shown in the screen below. (example for when only one EX600-SEC* is connected to the network.)

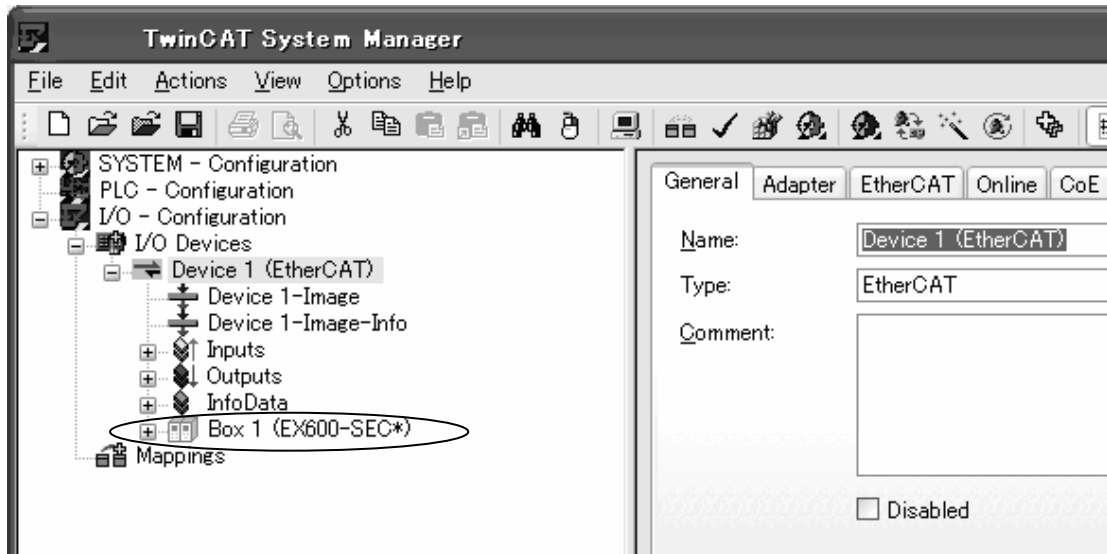

•Left click the [+] for [Box 1(EX600-SEC*)], to display the unit connected and the diagnostic status, as shown in the screen below.

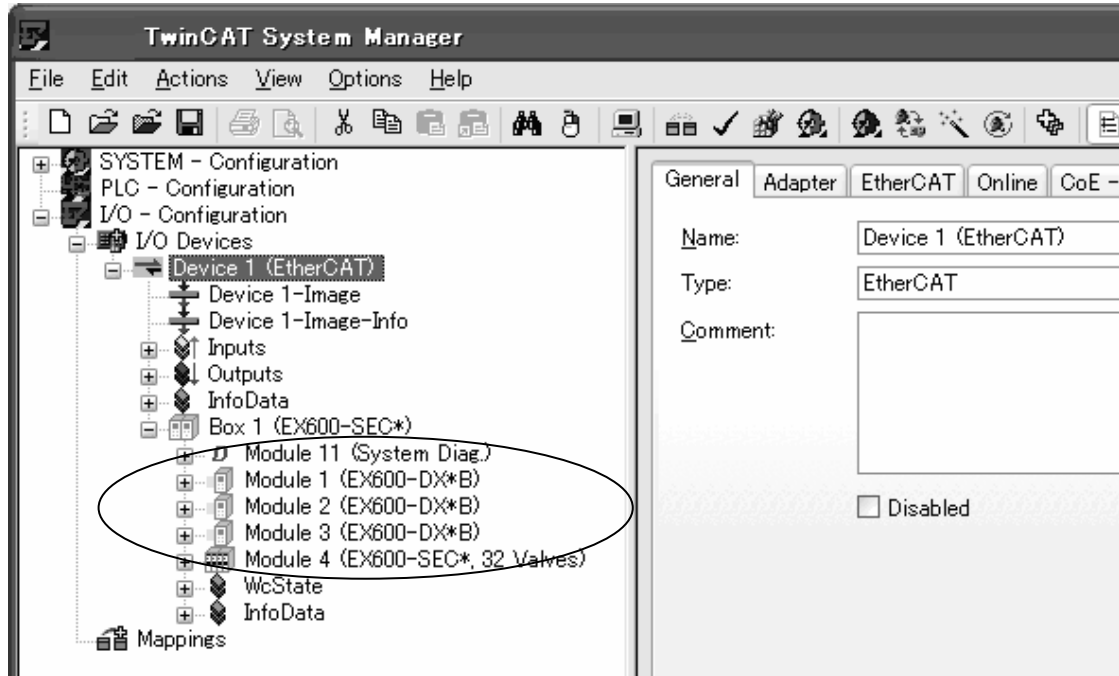

- *: The display above shows an example of the software configuration structure of the EX600 series.
- *: Allocate the diagnostic data to Module 11 when its setting is other than the diagnostic mode 0.
(The above shows diagnostic mode 1 is selected)

	Slot 0	Slot 1	Slot 2	Slot 3	
End plate	DX□B	DX□B	DX□B	SEC□	Valve
	Digital input	Digital input	Digital input	SI unit (32 output)	
	1 byte Input	1 byte Input	1 byte Input	4 byte Output	
	Module 1	Module 2	Module 3	Module 4	

- Off-line manual configuration method

- Right click the [I/O Devices] file, and then left click [Append Device] from the pop up menu.

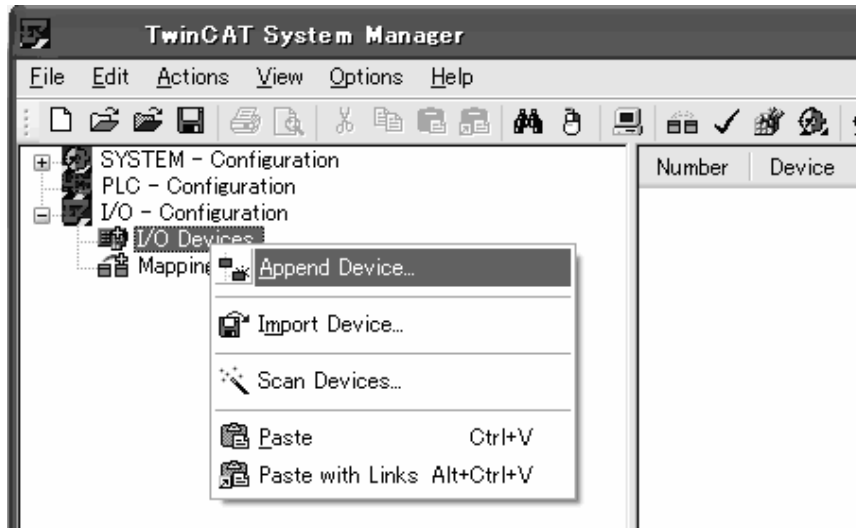

- The [Insert Device] window will be displayed. Left click the [+] button of the [EtherCAT] file, then left click the newly displayed [EtherCAT] file, and left click the [OK] button.



- [Device1(EtherCAT)] file will be added under the [I/O Devices]. Right click the [Device1(EtherCAT)] file, and then left click the [Box] file from the pop up menu.

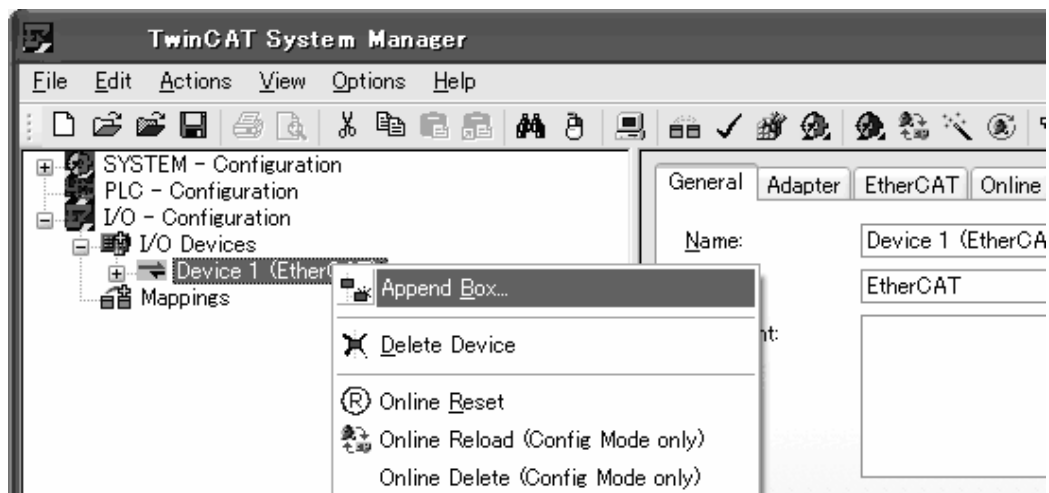

- The [Insert EtherCAT Device] window will be displayed. Left click the [+] button of the [SMC Corporation] file, left click the [+] button of the [EX600 Series SI Unit], left click the [EX600-SEC*EtherCAT SI Unit] file, and then left click the [OK] button.

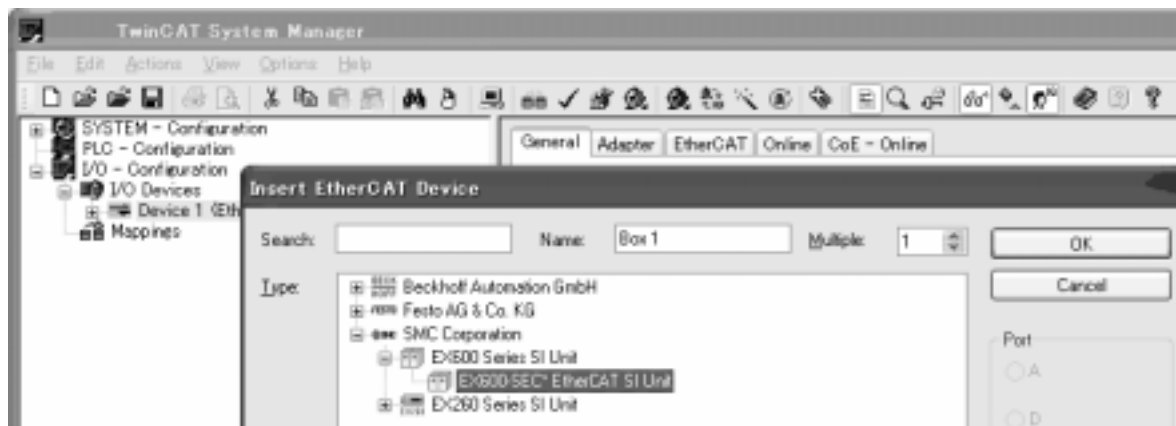

- [Box1(EX600-SEC*)] file will be added under the [Device1(EtherCAT)] file. Left click the [Box1(EX600-SEC*)] file, and then left click the [Slots] tab on the right screen.

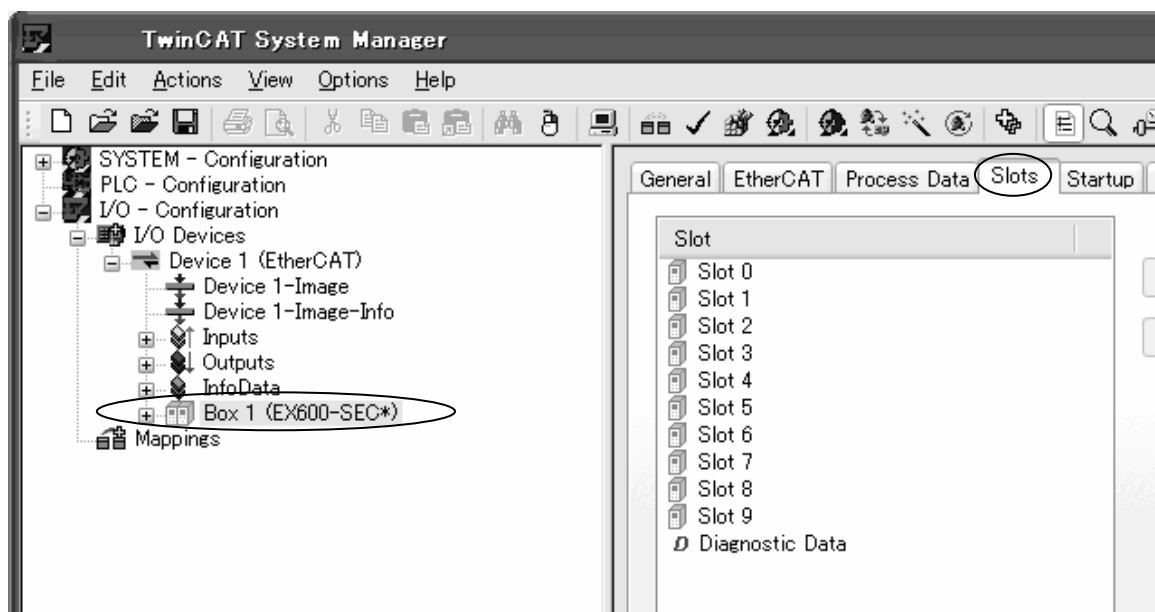

- When [Slot 0] in the Slot list on the left is selected, the product numbers of the EX600 series is displayed in the Module list in the right screen.

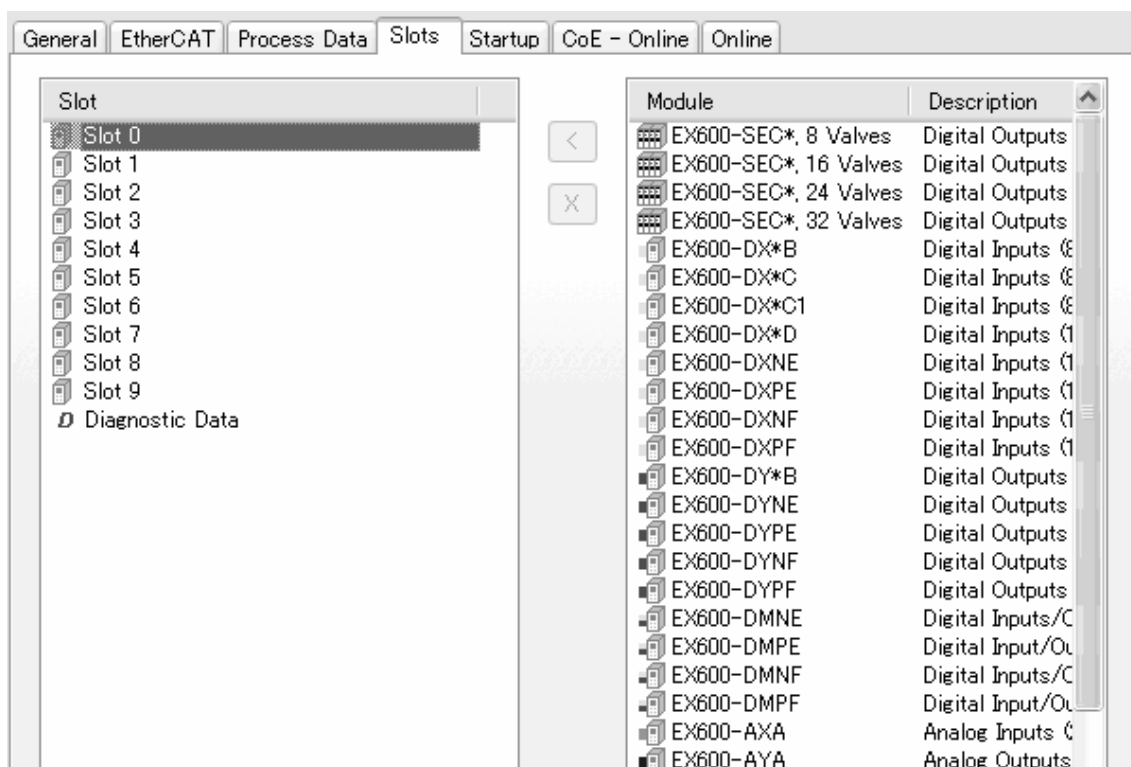

- Left click the product number of the EX600 series that is connected to [Slot 0] from the Module list on the right.
- Left click the [<] button. The selected unit is allocated as [Module1] in the Slot list [Slot 0] on the left.

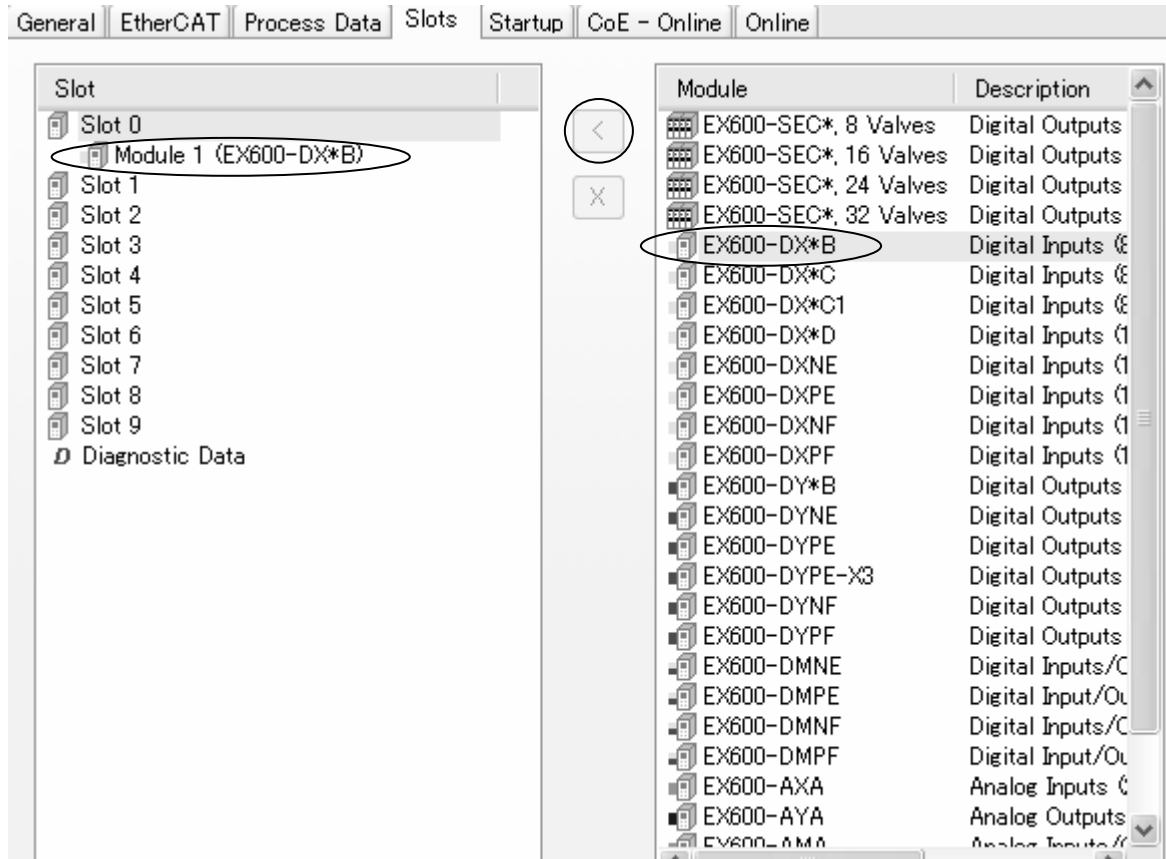

- Similarly, allocate all of the I/O units, SI unit and diagnostic data (when the diagnostic data is specified).
- Supply power after connecting the product. Then, click [Reload I/O Devices] to set the device on-line.

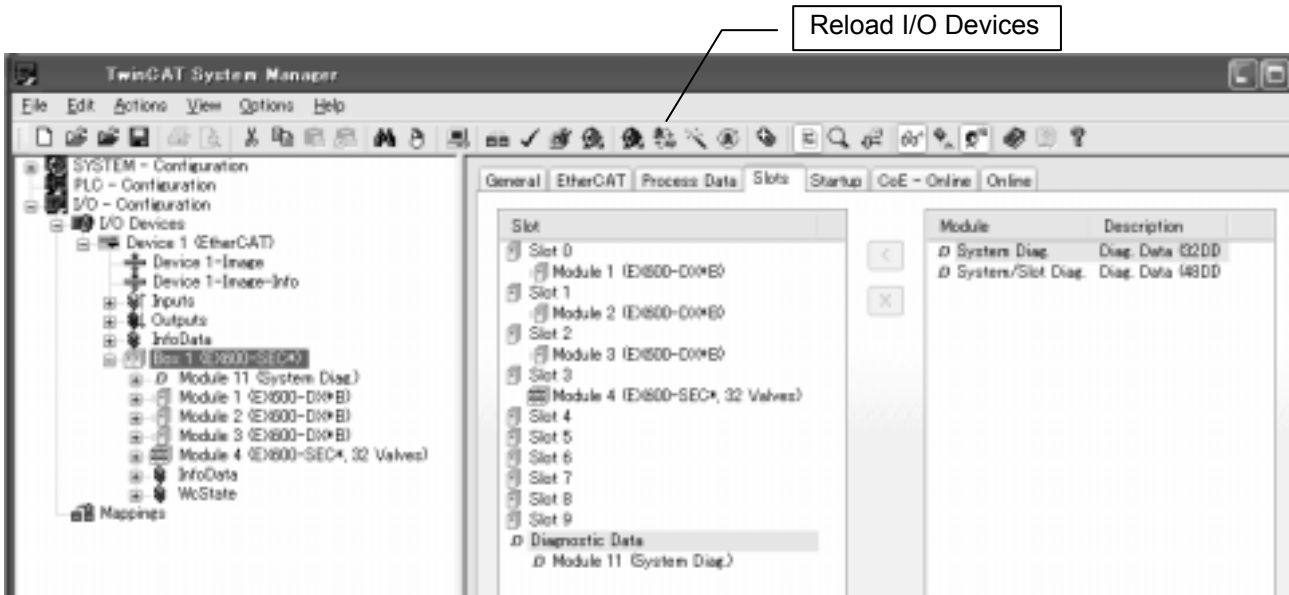

- *: The display above shows an example of the software configuration structure of the EX600 series.
- *: Allocate the diagnostic data to Module 11 when its setting is other than the diagnostic mode 0.
(The above shows when diagnostic mode 1 is selected)

	Slot 0	Slot 1	Slot 2	Slot 3	
End plate	DX□B	DX□B	DX□B	SEC□	Valve
	Digital output	Digital output	Digital output	SI unit (32 output)	
	1 byte Input	1 byte Input	1 byte Input	4 byte Output	
	Module 1	Module 2	Module 3	Module 4	

I/O Map

Each unit of the product has its own I/O occupied byte.

Unit	Unit part number	Occupied byte	
		Input	Output
SI unit	EX600-SEC□ (32 outputs)	0	4
	EX600-SEC□ (24 outputs)	0	3
	EX600-SEC□ (16 outputs)	0	2
	EX600-SEC□ (8 outputs)	0	1
Digital input unit	EX600-DX□B (8 inputs)	1	0
	EX600-DX□C (8 inputs)	1	0
	EX600-DX□C1 (8 inputs)(with open circuit detection)	1	0
	EX600-DX□D (16 inputs)	2	0
	EX600-DX□E (16 inputs)	2	0
	EX600-DX□F (16 inputs)	2	0
Digital output unit	EX600-DY□B (8 outputs)	0	1
	EX600-DY□E (16 outputs)	0	2
	EX600-DY□F (16 outputs)	0	2
Digital I/O unit	EX600-DM□E (8 inputs/8 outputs)	1	1
	EX600-DM□F (8 inputs/8 outputs)	1	1
Analogue input unit	EX600-AXA (2 channels)	4 (2 byte/1 channel)	0
Analogue output unit	EX600-AYA (2 channels)	0	4 (2 byte/1 channel)
Analogue I/O unit	EX600-AMB (2/2 channels)	4 (2 byte/1 channel)	4 (2 byte/1 channel)

Diagnostic

By changing the diagnosis switch, the diagnostic data shown below is assigned to the head of input data of the I/O map. (Refer to "Setting and adjustment" for setting the switch.)

Mode	Diagnostic data	Diagnostic size
0	No diagnostic data.	0 byte
1	System diagnosis	4 byte
2	System diagnosis + Unit diagnosis (Up to 10 units)	6 byte

*: Channel diagnosis cannot be assigned to the diagnosis area of the input.

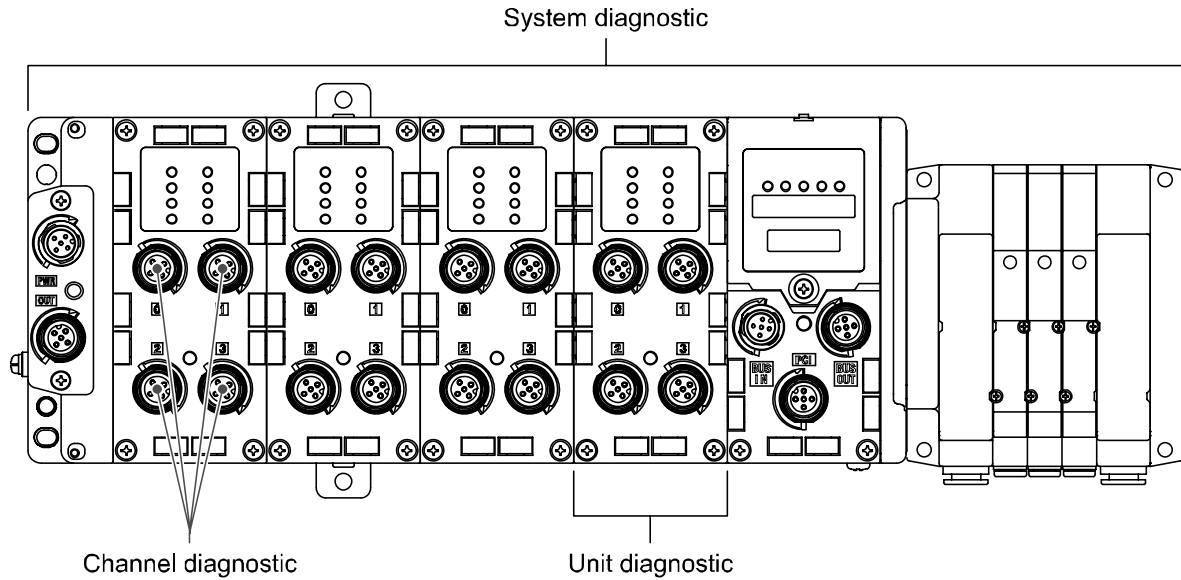

•I/O map assignment

I/O map of EX600 is assigned in order starting from the unit on the end plate side.

Taking the unit layout below as an example, the input/output map of each diagnosis mode is shown below.

	Slot 0	Slot 1	Slot 2	Slot 3	Slot 4	Slot 5	
End plate	AXA	DY□B	DY□B	DX□B	DX□D	SEC□	Solenoid valve manifold
	Analogue input	Digital output	Digital output	Digital input	Digital input	SI unit (32 output)	
	4 byte Input	1 byte Output	1 byte Output	1 byte Input	2 byte Input	4 byte Output	

Input data: Analogue input unit (EX600-AXA)_4 byte occupied (Slot 0)

Digital input unit (EX600-DX□B)_1 byte occupied (Slot 3)

Digital input unit (EX600-DX□D)_2 byte occupied (Slot 4)

Output data: Digital output unit(EX600-DY□B)_1 byte occupied (Slot 1)

Digital output unit (EX600-DY□B)_1 byte occupied (Slot 2)

SI unit (EX600-SEC□)_4 byte occupied (Slot 5)

•Diagnosis mode 0

	Input data	Output data
Byte0	AXA channel 0 (Slot 0)	DY□B (Slot 1)
Byte1		DY□B (Slot 2)
Byte2	AXA channel 1 (Slot 0)	SEC□ (Slot 5)
Byte3		
Byte4	DX□B (Slot 3)	
Byte5	DX□D (Slot 4)	
Byte6		
Total	7 byte	6 byte

•Diagnosis mode 1

	Input data	Output data	
Byte0	System diagnosis byte0	DY□B (Slot 1)	
Byte1	System diagnosis byte1	DY□B (Slot 2)	
Byte2	System diagnosis byte2	SEN□ (Slot 5)	
Byte3	System diagnosis byte3		
Byte4	AXA channel 0 (Slot 0)		
Byte5			
Byte6	AXA channel 1 (Slot 0)	/	
Byte7			
Byte8	DX□B (Slot 3)		
Byte9	DX□D (Slot 4)		
Byte10			
Total	11 byte		6 byte

•Diagnosis mode 2

	Input data	Output data	
Byte0	System diagnosis byte0	DY□B (Slot 1)	
Byte1	System diagnosis byte1	DY□B (Slot 2)	
Byte2	System diagnosis byte2	SEN□ (Slot 5)	
Byte3	System diagnosis byte3		
Byte4	Unit diagnosis byte0		
Byte5	Unit diagnosis byte1	/	
Byte6	AXA channel 0 (Slot 0)		
Byte7			
Byte8	AXA channel 1 (Slot 0)		
Byte9			
Byte10	DX□B (Slot 3)		
Byte11	DX□D (Slot 4)		
Byte12			
Total	13 byte		6 byte

■Details of diagnostic data

•System diagnosis

•System diagnosis byte0

Bit No.	Content of diagnosis
0	The analogue value has fallen below the user set value.
1	The analogue value has exceeded the user set value.
2	The analogue input value has fallen below the set range.
3	The analogue input value has exceeded the set range.
4	ON/OFF count has exceeded the set value.
5	The open circuit has been detected.
6	The short circuit of the valve output or digital output has been detected.
7	The short circuit of the power supply for the input/output device has been detected.

•System diagnosis byte1

Bit No.	Content of diagnosis
0	The power supply voltage for output device is outside of the specification.
1	The power supply voltage for control and input device is outside of the specification.
2	Reserved
3	There is a connection failure between each unit (During operation).
4	There is a connection failure between each unit (When the power supply is applied).
5	Reserved
6	System error occurred.
7	Hardware error occurred.

•System diagnosis byte2

Bit No.	Content of diagnosis
0	Reserved
:	:
7	Reserved

•System diagnosis byte3

Bit No.	Content of diagnosis
0	There is an error in the Digital input unit. *1
1	There is an error in the Digital output unit. *1
2	There is an error in the Analogue input unit. *2
3	There is an error in the Analogue output unit. *2
4	There is an error in the SI unit.
5	Reserved
6	Reserved
7	Reserved

*1: When the error occurs in the Digital I/O unit, both Bit0 and Bit1 are turned on.

*2: When the error occurs in the Analogue I/O unit, both Bit2 and Bit3 are turned on.

•Unit diagnosis

•Unit diagnosis byte0

Bit No.	Content of diagnosis
0	There is an error in Slot 0.
1	There is an error in Slot 1.
2	There is an error in Slot 2.
3	There is an error in Slot 3.
4	There is an error in Slot 4.
5	There is an error in Slot 5.
6	There is an error in Slot 6.
7	There is an error in Slot 7.

•Unit diagnosis byte1

Bit No.	Content of diagnosis
0	There is an error in Slot 8.
1	There is an error in Slot 9.
2	Reserved
3	Reserved
4	Reserved
5	Reserved
6	Reserved
7	Reserved

Parameter settings using TwinCAT® (SDO communication)

How to set the parameters using TwinCAT® System Manager is shown below.

- EX600 series supports the SDO (Service Data Object) communication.
- SDO Upload service or SDO Download service can be used to set parameters and monitor the input/output status and diagnosis status of the EX600 series.

●Object Dictionary

Object composition can mainly be classified into 2 types.

- Standard object (Index 1□□□)
- Device specific object (Index 6□□□, 7□□□, 8□□□, 9□□□, F□□□)

•Standard object

Index	Name	Flags	Fixed value
1000	Device type	RO	0x00001389 (5001dec)
1008	Device name	RO	EX600-SEC□
1009	Hardware version	RO	V1.00
100A	Software version	RO	V1.00
1018:0	Identity	RO	0x03 (3dec)
1018:01	Vendor ID	RO	0x00000114 (276dec)
1018:02	Product code	RO	0x01000005 (16777221dec)
1018:03	Revision	RO	0x00010001 (65537dec)
1600 - 160A	RxPDO-Map (DO or AO)	RO	
1A00 - 1A0A	TxPDO-Map (DI or AI, Diag.)	RO	
1C00:0	Sync manager type	RO	
1C12:0	RxPDO assign	RO	
1C13:0	TxPDO assign	RO	

*: Standard object conforms to the EtherCAT specifications.

*: RO = Read Only

•Device specific object

Index	Name	Flags	Meaning
6000 - 60A0	Module Input Data	RO P	Input data
7000 - 70A0	Module Output Data	RO P	Output data
8000 - 80A0	Configuration Data	RO/RW	Parameter setting data
9000 - 90A0	Information Data	RO/RW	Diagnostic data
F000 - F050	Modular device profile	RO	EX600 composition information

*: RO = Read Only, RW = Read/Write, RO P = Read Only_Process data

•Device specific object compositions

This object varies depending on the EX600 system composition.

The parameter composition examples given below are for when the following system is composed:

DX□B	DY□B	DM□E	AXA	AYA	AMB	SI unit Valve 16	System Diag.
Slot 0	Slot 1	Slot 2	Slot 3	Slot 4	Slot 5	Slot 6	Diag.

Fig. System composition example

•Module Input Data (Device specific object)

Table. Module Input Data composition example

Index	Name / Meaning	Slot No.
6000:0	Digital Inputs / DX□B	Slot 0
6000:01	Channel 0	
...	...	
6000:08	Channel 7	
6010:0	(No input data allocation)	Slot 1
6020:0	Digital Inputs / DM□E	Slot 2
6020:01	Channel 0	
...	...	
6020:08	Channel 7	
6030:0	Analog Inputs / AXA	Slot 3
6030:01	Channel 0	
6030:02	Channel 1	
6040:0	No input data allocation	Slot 4
6050:0	(Analog Inputs / AMB)	Slot 5
6050:01	Channel 0	
6050:02	Channel 1	
6060:0	(No input data allocation)	Slot 6
60A0:0	Diag. Data / System Diag.	Diag.
60A0:01	Under lower limit value	
...	...	
60A0:1D	SI unit	

•Module Output Data (Device specific object)

Table. Module Output Data composition example

Index	Name / Meaning	Slot No.
7000:0	(No output data allocation)	Slot 0
7010:0	Digital Outputs / DY(B)	Slot 1
7010:01	Channel 0	
...	...	
7010:08	Channel 7	
7020:0	Digital Outputs / DM(E)	Slot 2
7020:01	Channel 0	
...	...	
7020:08	Channel 7	
7030:0	(No output data allocation)	Slot 3
7040:0	Analog Outputs / AYA	Slot 4
7040:01	Channel 0	
7040:02	Channel 1	
7050:0	Analog Outputs / AMB	Slot 5
7050:01	Channel 2	
7050:02	Channel 3	
7060:0	Valve Outputs / SI unit	Slot 6
7060:01	Channel 0	
...	...	
7060:10	Channel 15	
70A0:0	(No output data allocation)	Diag.

•Configuration Data (Device specific object)

Table. Configuration Data composition example

Index	Name / Meaning	Slot No.
8000:0	Module identification / DX□B	Slot 0
8001:0	Unit Parameters	
8006:0	Monitor count	
8007:0	Count value (x1000)	
8010:0	Module identification / DY□B	Slot 1
8011:0	Unit Parameters	
8012:0	Fault mode	
8013:0	Fault value	
8014:0	Idle mode	
8015:0	Idle value	
8016:0	Monitor count	
8017:0	Count value (x1000)	
8018:0	Monitor open circuit	Slot 2
8020:0	Module identification / DM□E	
8021:0	Unit Parameters	
8022:0	Fault mode	
8023:0	Fault value	
8024:0	Idle mode	
8025:0	Idle value	
8026:0	Monitor count	
8027:0	Count value (x1000)	Slot 3
8028:0	Monitor open circuit	
8030:0	Module identification / AXA	
8031:0	Unit Parameters	
8036:0	Monitor upper limit	
8037:0	Upper limit value	
8038:0	Monitor lower limit	
8039:0	Lower limit value	Slot 4
803A:0	Filter	
803B:0	Range	
8040:0	Module identification / AYA	
8041:0	Unit Parameters	
8042:0	Fault mode	
8043:0	Fault value	
8044:0	Idle mode	
8045:0	Idle value	
8046:0	Monitor upper limit	
8047:0	Upper limit value	
8048:0	Monitor lower limit	
8049:0	Lower limit value	
804B:0	Range	

Table. Configuration Data composition example (continued)

Index	Name / Meaning	Slot No.
8050:0	Module identification / AMB	Slot 5
8051:0	Unit Parameters	
8052:0	Fault mode	
8053:0	Fault value	
8054:0	Idle mode	
8055:0	Idle value	
8056:0	Monitor upper limit	
8057:0	Upper limit value	
8058:0	Monitor lower limit	
8059:0	Lower limit value	
805A:0	Filter	
805B:0	Range	
8060:0	Module identification / SI unit	
8061:0	Unit Parameters	
8062:0	Fault mode	
8063:0	Fault value	
8064:0	Idle mode	
8065:0	Idle value	
8066:0	Monitor count	
8067:0	Count value (x1000)	
8068:0	Monitor open circuit	
806F:0	System parameter	
80A0:0	Module identification / System Diag.	Diag.

•Information Data (Device specific object)

Table. Information Data composition example

Index	Name / Meaning	Slot No.
9000:0	Module identification / DX□B	Slot 0
9001:0	Short circuit	
9002:0	Over ON/OFF counter	
9004:0	Counter	
9010:0	Module identification / DY□B	Slot 1
9011:0	Short circuit	
9012:0	Over ON/OFF counter	
9013:0	Open circuit	
9014:0	Counter	
9020:0	Module identification / DM□E	Slot 2
9021:0	Short circuit	
9022:0	Over ON/OFF counter	
9023:0	Open circuit	
9024:0	Counter	
9030:0	Module identification / AXA	Slot 3
9031:0	Short circuit	
9032:0	Over range	
9033:0	Under range	
9034:0	Over upper limit value	
9035:0	Under lower limit value	
9040:0	Module identification / AYA	Slot 4
9041:0	Short circuit	
9044:0	Over upper limit value	
9045:0	Under lower limit value	
9050:0	Module identification / AMB	Slot 5
9051:0	Short circuit	
9052:0	Over range	
9053:0	Under range	
9054:0	Over upper limit value	
9055:0	Under lower limit value	
9060:0	Module identification / SI unit	Slot 6
9061:0	Short circuit	
9062:0	Over ON/OFF counter	
9063:0	Open circuit	
9064:0	Counter	
9066:0	System error	
9067:0	Error log	
90A0:0	Module identification / System Diag.	Diag.

- Object Dictionary for user set-up
- Enumeration definition

Table. User setup Object Dictionary

Index	Base Type	Value	Text
0800	USINT	0	0.1 ms
		1	1 ms
		2	10 ms
		3	20 ms
0801	USINT	0	1 ms
		1	15 ms
		2	100 ms
		3	200 ms
0802	USINT	0	Offset binary
		1	Sign & magnitude
		2	2's complement
		3	Scaled
0803	USINT	0	None
		1	2 value average
		2	4 value average
		3	8 value average
0804	USINT	0	-10...+10 V
		1	-5...+5 V
		2	-20...+20 mA
		3	0...10 V
		4	0...5 V
		5	1...5 V
		6	0...20 mA
		7	4...20 mA
0805	USINT	0	0...10 V
		1	0...5 V
		2	1...5 V
		3	0...20 mA
		4	4...20 mA
0806	USINT	0	Switch
		1	Parameter
0807	USINT	0	Disable
		1	Enable
0808	USINT	0	Manual
		1	Auto
0809	USINT	0	Off
		1	On
080A	USINT	0	Offset binary
		1	Sign & magnitude
		2	2's complement

●Device specific object parameter details

•Module Input Data

Digital input unit (EX600-DX□□ or EX600-DM□□)

Table. Module Input Data (DX or DM)

Index	Name / Meaning	Type	Flags	Value
60x0:0	Slot x: Digital Inputs	USINT	RO	Number of channels
60x0:01	Channel 0	BOOL	RO P	FALSE (OFF) TRUE (ON)
...

*: x = Slot No.

Analogue input unit (EX600-AXA or EX600-AMB)

Table. Module Input Data (AX or AM)

Index	Name / Meaning	Type	Flags	Value
60x0:0	Slot x: Analog Inputs	USINT	RO	Number of channels
60x0:01	Channel 0	UINT	RO P	0 to 65535
60x0:02	Channel 1	UINT	RO P	0 to 65535

*: x = Slot No.

•Diagnostic data

Table. Module Input Data (Diag.)

Index	Name / Meaning	Type	Flags	Value
60A0:0	Diag. data	USINT	RO	29 or 42
60A0:01	Under lower limit value	BOOL	RO P	FALSE (Undetected) TRUE (Detected)
60A0:02	Over upper limit value	BOOL	RO P	
60A0:03	Under range	BOOL	RO P	
60A0:04	Over range	BOOL	RO P	
60A0:05	Over ON/OFF counter	BOOL	RO P	
60A0:06	Open circuit	BOOL	RO P	
60A0:07	Short circuit (out)	BOOL	RO P	
60A0:08	Short circuit (in)	BOOL	RO P	
60A0:09	Pwr output is out of range	BOOL	RO P	
60A0:0A	Pwr control is out of range	BOOL	RO P	
60A0:0C	Unit disconnection	BOOL	RO P	
60A0:0D	Connection error	BOOL	RO P	
60A0:0F	Memory error	BOOL	RO P	
60A0:10	Parameter read/write error	BOOL	RO P	
60A0:19	Digital input unit	BOOL	RO P	
60A0:1A	Digital output unit	BOOL	RO P	
60A0:1B	Analog input unit	BOOL	RO P	
60A0:1C	Analog output unit	BOOL	RO P	
60A0:1D	SI unit	BOOL	RO P	
60A0:21	Slot 0	BOOL	RO P	
60A0:22	Slot 1	BOOL	RO P	
60A0:23	Slot 2	BOOL	RO P	
60A0:24	Slot 3	BOOL	RO P	
60A0:25	Slot 4	BOOL	RO P	
60A0:26	Slot 5	BOOL	RO P	
60A0:27	Slot 6	BOOL	RO P	
60A0:28	Slot 7	BOOL	RO P	
60A0:29	Slot 8	BOOL	RO P	
60A0:2A	Slot 9	BOOL	RO P	

•Module Output Data
SI unit (EX600-SEC□)

Table. Module Output Data (SI)

Index	Name / Meaning	Type	Flags	Value
70x0:0	Slot x: Valve Outputs	USINT	RO	Number of channels
70x0:01	Channel 0	BOOL	RO P	FALSE (OFF) TRUE (ON)
...

*: x: Slot No.

Digital output unit (EX600-DY□□ or EX600-DM□□)

Table. Module Output Data (DY or DM)

Index	Name / Meaning	Type	Flags	Value
70x0:0	Slot x: Digital Outputs	USINT	RO	Number of channels
70x0:01	Channel 0	BOOL	RO P	FALSE (OFF) TRUE (ON)
...

*: x: Slot No.

Analogue output unit (EX600-AYA or EX600-AMB)

Table. Module Output Data (AY or AM)

Index	Name / Meaning	Type	Flags	Value
70x0:0	Slot x: Analog Outputs	USINT	RO	Number of channels
70x0:01	Channel 0	UINT	RO P	0 to 65535
70x0:02	Channel 1	UINT	RO P	0 to 65535

*: x: Slot No.

•Configuration Data
SI unit (EX600-SEC□)

Table. Configuration Data (SI)

Index	Name / Meaning	Type	Value
80x0:0	Slot x: Module identification	USINT	10
80x0:01	Address of the module	UINT	Slot No.
80x0:09	Module PDO group	UINT	2
80x0:0A	Module ident	DINT	Unit ID
80x1:0	Slot x: Unit Parameters	USINT	8
80x1:02	Monitor short circuit (out)	Enum0807	0=Disable 1=Enable
80x1:06	Restart after short circuit	Enum0808	0=Manual 1=Auto
80x1:07	Monitor 24V_C / Monitoring the power supply voltage (For control and input)	Enum0807	0=Disable 1=Enable
80x1:08	Monitor 24V_D / Monitoring the power supply voltage (For output)	Enum0807	0=Disable 1=Enable
80x2:0	Slot x: Fault mode	USINT	Number of channels
80x2:01	Channel 0 / Output setting during communication fault	Enum0807	0=Disable (Hold) 1=Enable (Clear or Force ON)
...
80x3:0	Slot x: Fault value	USINT	Number of channels
80x3:01	Channel 0 / Output setting value during communication fault	Enum0809	0=Off (Clear) 1=On (Force ON)
...
80x4:0	Slot x: Idle mode	USINT	Number of channels
80x4:01	Channel 0 / Output setting during communication idling	Enum0807	0=Disable (Hold) 1=Enable (Clear or Force ON)
...
80x5:0	Slot x: Idle value	USINT	Number of channels
80x5:01	Channel 0 / Output setting value during communication idling	Enum0809	0=Off (Clear) 1=On (Force ON)
...
80x6:0	Slot x: Monitor count	USINT	Number of channels
80x6:01	Channel 0 / ON-OFF counter upper limit	Enum0807	0=Disable 1=Enable
...
80x7:0	Slot x: Count value (x1000)	USINT	Number of channels
80x7:01	Channel 0 / ON-OFF frequency upper limit	UINT	1 to 65000 (Times diagnostic has been detected=Set value x1000)
...

Table. Configuration Data (SI) (continued)

Index	Name / Meaning	Type	Value
80x8:0	Slot x: Monitor open circuit	USINT	Number of channels
80x8:01	Channel 0 / Open circuit detection	Enum0807	0=Disable 1=Enable
...
80xF:0	Slot x: System parameter	USINT	2
80xF:02	Hold/Clear	Enum0806	0=Switch 1=H.T. or parameter

*: x: Slot No.

Digital input unit (EX600-DX□□)

Table. Configuration Data (DX)

Index	Name / Meaning	Type	Value
80x0:0	Slot x: Module identification	USINT	10
80x0:01	Address of the module	UINT	Slot No.
80x0:09	Module PDO group	UINT	2
80x0:0A	Module ident	DINT	Unit ID
80x1:0	Slot x: Unit Parameters	USINT	11
80x1:01	Monitor short circuit (in)	Enum0807	0=Disable 1=Enable
80x1:05	Inrush current filter	Enum0807	0=Disable 1=Enable
80x1:09	Digital input filtering time	Enum0800	0=0.1 ms 1=1 ms 2=10 ms 3=20 ms
80x1:0B	Digital input extension time	Enum0801	0=1 ms 1=15 ms 2=100 ms 3=200 ms
80x6:0	Slot x: Monitor count	USINT	Number of channels
80x6:01	Channel 0 / ON-OFF counter upper limit	Enum0807	0=Disable 1=Enable
...
80x7:0	Slot x: Count Value (x1000)	USINT	Number of channels
80x7:01	Channel 0 / ON-OFF frequency upper limit	UINT	1 to 65000 (Times diagnostic has been detected=Set value x1000)
...
80x8:0 *1	Slot x: Monitor open circuit	USINT	Number of channels
80x8:01 *1	Channel 0 / Open circuit detection	Enum0807	0=Disable 1=Enable
... *1

*: x: Slot No.

*1: Applicable to the open detecting digital input unit (EX600-DXC1).

Digital output unit (EX600-DY□□)

Table. Configuration Data (DY)

Index	Name / Meaning	Type	Value
80x0:0	Slot x: Module identification	USINT	10
80x0:01	Address of the module	UINT	Slot No.
80x0:09	Module PDO group	UINT	2
80x0:0A	Module ident	DINT	Unit ID
80x1:0	Slot x: Unit Parameters	USINT	6
80x1:02	Monitor short circuit (out)	Enum0807	0=Disable 1=Enable
80x1:06	Restart after short circuit	Enum0808	0=Manual 1=Auto
80x2:0	Slot x: Fault mode	USINT	Number of channels
80x2:01	Channel 0 / Output setting during communication fault	Enum0807	0=Disable (Hold) 1=Enable (Clear or Force ON)
...
80x3:0	Slot x: Fault value	USINT	Number of channels
80x3:01	Channel 0 / Output setting value during communication fault	Enum0809	0=Off (Clear) 1=On (Force ON)
...
80x4:0	Slot x: Idle mode	USINT	Number of channels
80x4:01	Channel 0 / Output setting during communication idling	Enum0807	0=Disable (Hold) 1=Enable (Clear or Force ON)
...
80x5:0	Slot x: Idle value	USINT	Number of channels
80x5:01	Channel 0 / Output setting value during communication idling	Enum0809	0=Off (Clear) 1=On (Force ON)
...
80x6:0	Slot x: Monitor count	USINT	Number of channels
80x6:01	Channel 0 / ON-OFF counter upper limit	Enum0807	0=Disable 1=Enable
...
80x7:0	Slot x: Count value (x1000)	USINT	Number of channels
80x7:01	Channel 0 / ON-OFF frequency upper limit	UINT	1 to 65000 (Times diagnostic has been detected=Set value x1000)
...
80x8:0	Slot x: Monitor open circuit	USINT	Number of channels
80x8:01	Channel 0 / Open circuit detection	Enum0807	0=Disable 1=Enable
...

*: x: Slot No.

Digital I/O unit (EX600-DM□□)

Table. Configuration Data (DM)

Index	Name / Meaning	Type	Value
80x0:0	Slot x: Module identification	USINT	10
80x0:01	Address of the module	UINT	Slot No.
80x0:09	Module PDO group	UINT	2
80x0:0A	Module ident	DINT	Unit ID
80x1:0	Slot x: Unit Parameters	USINT	11
80x1:01	Monitor short circuit (in)	Enum0807	0=Disable 1=Enable
80x1:02	Monitor short circuit (out)	Enum0807	0=Disable 1=Enable
80x1:05	Inrush current filter	Enum0807	0=Disable 1=Enable
80x1:06	Restart after short circuit	Enum0808	0=Manual 1=Auto
80x1:09	Digital input filtering time	Enum0800	0=0.1 ms 1=1 ms 2=10 ms 3=20 ms
80x1:0B	Digital input extension time	Enum0801	0=1 ms 1=15 ms 2=100 ms 3=200 ms
80x2:0	Slot x: Fault mode	USINT	Number of output channels
80x2:01	Channel 0 (Out) / Output setting during communication fault	Enum0807	0=Disable (Hold) 1=Enable (Clear or Force ON)
...
80x3:0	Slot x: Fault value	USINT	Number of output channels
80x3:01	Channel 0 (Out) / Output setting value during communication fault	Enum0809	0=Off (Clear) 1=On (Force ON)
...
80x4:0	Slot x: Idle mode	USINT	Number of output channels
80x4:01	Channel 0 (Out) / Output setting during communication idling	Enum0807	0=Disable (Hold) 1=Enable (Clear or Force ON)
...
80x5:0	Slot x: Idle value	USINT	Number of output channels
80x5:01	Channel 0 (Out) / Output setting value during communication idling	Enum0809	0=Off (Clear) 1=On (Force ON)
...
80x6:0	Slot x: Monitor count	USINT	Number of all channels
80x6:01	Channel 0 (In) / ON-OFF count upper limit detection	Enum0807	0=Disable 1=Enable
...

Table. Configuration Data (DM) (continued)

Index	Name / Meaning	Type	Value
80x7:0	Slot x: Count value (x1000)	USINT	Number for all channels
80x7:01	Channel 0 (In) / Counter diagnostic detection	UINT	1 to 65000 (Times diagnostic has been detected=Set value x1000)
...
80x8:0	Slot x: Monitor open circuit	USINT	Number of output channels
80x8:01	Channel 0 (Out) / Open circuit detection	Enum0807	0=Disable 1=Enable
...

*: x: Slot No.

Analogue input unit (EX600-AXA)

Table. Configuration Data (AX)

Index	Name / Meaning	Type	Value
80x0:0	Slot x: Module identification	USINT	10
80x0:01	Address of the module	UINT	Slot No.
80x0:09	Module PDO group	UINT	1
80x0:0A	Module ident	DINT	32
80x1:0	Slot x: Unit Parameters	USINT	13
80x1:01	Monitor short circuit (in)	Enum0807	0=Disable 1=Enable
80x1:03	Monitor over range	Enum0807	0=Disable 1=Enable
80x1:04	Monitor under range	Enum0807	0=Disable 1=Enable
80x1:0D	Data format	Enum080A	0=Offset binary 1=Sign & Magnitude 2=2's complement
80x6:0	Slot x: Monitor upper limit	USINT	2
80x6:01	Channel 0 / Monitor user set upper limit	Enum0807	0=Disable 1=Enable
80x6:02	Channel 1 / Monitor user set upper limit		
80x7:0	Slot x: Upper limit value	USINT	2
80x7:01	Channel 0 / User set upper limit value	UINT	0 to 65535
80x7:02	Channel 1 / User set upper limit value		
80x8:0	Slot x: Monitor lower limit	USINT	2
80x8:01	Channel 0 / Monitor user set lower limit	Enum0807	0=Disable 1=Enable
80x8:02	Channel 1 / Monitor user set lower limit		
80x9:0	Slot x: Lower limit value	USINT	2
80x9:01	Channel 0 / User set lower limit value	UINT	0 to 65535
80x9:02	Channel 1 / User set lower limit value		
80xA:0	Slot x: Filter	USINT	2
80xA:01	Channel 0 / Analogue average filter	Enum0803	0=None 1=2 value average 2=4 value average 3=8 value average
80xA:02	Channel 1 / Analogue average filter		
80xB:0	Slot x: Range	USINT	2
80xB:01	Channel 0 / Analogue input range	Enum0804	0=-10...+10 V 1=-5...+5 V 2=-20...+20 mA 3=0...10 V 4=0...5 V 5=1...5 V 6=0...20 mA 7=4...20 mA
80xB:02	Channel 1 / Analogue input range		

*: x: Slot No.

Analogue output unit (EX600-AYA)

Table. Configuration Data (AY)

Index	Name / Meaning	Type	Value
80x0:0	Slot x: Module identification	USINT	10
80x0:01	Address of the module	UINT	Slot No.
80x0:09	Module PDO group	UINT	1
80x0:0A	Module ident	DINT	34
80x1:0	Slot x: Unit Parameters	USINT	13
80x1:01	Monitor short circuit (in)	Enum0807	0=Disable 1=Enable
80x1:0D	Data format	Enum0802	0=Offset binary 1=Sign & Magnitude 2=2's complement 3=Scaled
80x2:0	Slot x: Fault mode	USINT	2
80x2:01	Channel 0 / Output setting during communication fault	Enum0807	0=Disable (Hold) 1=Enable (Fault value)
80x2:02	Channel 1 / Output setting during communication fault		
80x3:0	Slot x: Fault value	USINT	2
80x3:01	Channel 0 / Output setting value during communication fault	UINT	0 to 65535
80x3:02	Channel 1 / Output setting value during communication fault		
80x4:0	Slot x: Idle mode	USINT	2
80x4:01	Channel 0 / Output setting during communication idling	Enum0807	0=Disable (Hold) 1=Enable (Fault value)
80x4:02	Channel 1 / Output setting during communication idling		
80x5:0	Slot x: Idle value	USINT	2
80x5:01	Channel 0 / Output setting value during communication idling	UINT	0 to 65535
80x5:02	Channel 1 / Output setting value during communication idling		
80x6:0	Slot x: Monitor upper limit	USINT	2
80x6:01	Channel 0 / Monitor user set upper limit	Enum0807	0=Disable 1=Enable
80x6:02	Channel 1 / Monitor user set upper limit		
80x7:0	Slot x: Upper limit value	USINT	2
80x7:01	Channel 0 / User set upper limit value	UINT	0 to 65535
80x7:02	Channel 1 / User set upper limit value		

Table. Configuration Data (AY) (continued)

Index	Name / Meaning	Type	Value
80x8:0	Slot x: Monitor lower limit	USINT	2
80x8:01	Channel 0 / Monitor user set lower limit	Enum0807	0=Disable 1=Enable
80x8:02	Channel 1 / Monitor user set lower limit		
80x9:0	Slot x: Lower limit value	USINT	2
80x9:01	Channel 0 / User set lower limit value	UINT	0 to 65535
80x9:02	Channel 1 / User set lower limit value		
80xB:0	Slot x: Range	USINT	2
80xB:01	Channel 0 / Analogue output range	Enum0805	0=0...10 V 1=0...5 V 2=1...5 V 3=0...20 mA 4=4...20 mA
80xB:02	Channel 1 / Analogue output range		

*: x: Slot No.

Analogue I/O unit (EX600-AMB)

Table. Configuration Data (AM)

Index	Name / Meaning	Type	Value
80x0:0	Slot x: Module identification	USINT	10
80x0:01	Address of the module	UINT	Slot No.
80x0:09	Module PDO group	UINT	1
80x0:0A	Module ident	DINT	35
80x1:0	Slot x: Unit Parameters	USINT	13
80x1:01	Monitor short circuit (in)	Enum0807	0=Disable 1=Enable
80x1:03	Monitor over range	Enum0807	0=Disable 1=Enable
80x1:04	Monitor under range	Enum0807	0=Disable 1=Enable
80x1:0D	Data format	Enum0802	0=Offset binary 1=Sign & Magnitude 2=2's complement 3=Scaled
80x2:0	Slot x: Fault mode	USINT	2
80x2:01	Channel 2 / Output setting during communication fault	Enum0807	0=Disable (Hold) 1=Enable (Fault value)
80x2:02	Channel 3 / Output setting during communication fault		
80x3:0	Slot x: Fault value	USINT	2
80x3:01	Channel 2 / Output setting value during communication fault	UINT	0 to 65535
80x3:02	Channel 3 / Output setting value during communication fault		
80x4:0	Slot x: Idle mode	USINT	2
80x4:01	Channel 2 / Output setting during communication idling	Enum0807	0=Disable (Hold) 1=Enable (Fault value)
80x4:02	Channel 3 / Output setting during communication idling		
80x5:0	Slot x: Idle value	USINT	2
80x5:01	Channel 2 / Output setting value during communication idling	UINT	0 to 65535
80x5:02	Channel 3 / Output setting value during communication idling		
80x6:0	Slot x: Monitor upper limit	USINT	4
80x6:01	Channel 0 / Monitor user set upper limit	Enum0807	0=Disable 1=Enable
...

Table. Configuration Data (AM) (continued)

Index	Name / Meaning	Type	Value
80x7:0	Slot x: Upper limit value	USINT	4
80x7:01	Channel 0 / User set upper limit value	UINT	0 to 65535
...
80x8:0	Slot x: Monitor lower limit	USINT	4
80x8:01	Channel 0 / Monitor user set lower limit	Enum0807	0=Disable 1=Enable
...
80x9:0	Slot x: Lower limit value	USINT	4
80x9:01	Channel 0 / User set lower limit value	UINT	0 to 65535
...
80xA:0	Slot x: Filter	USINT	2
80xA:01	Channel 0 / Analogue average filter	Enum0803	0=None 1=2 value average 2=4 value average 3=8 value average
80xA:02	Channel 1 / Analogue average filter		
80xB:0	Slot x: Range	USINT	4
80xB:01	Channel 0 / Analogue range	Enum0805	0=0...10 V 1=0...5 V 2=1...5 V 3=0...20 mA 4=4...20 mA
...

*: x: Slot No.

*: Channel 0 and 1 indicate analogue input, and Channel 2 and 3 indicate analogue output.

•Diagnostic data

Table. Configuration Data (Diag.)

Index	Name / Meaning	Type	Value
80A0:0	Diag.: Module identification	USINT	10
80A0:01	Address of the module	UINT	10
80A0:09	Module PDO group	UINT	0
80A0:0A	Module ident	DINT	256 or 257

•Information Data
SI unit (EX600-SEC□)

Table. Information Data (SI)

Index	Name / Meaning	Type	Value
90x0:0	Slot x: Module identification	USINT	10
90x0:01	Address of the module	UINT	Slot No.
90x0:09	Module PDO group	UINT	2
90x0:0A	Module ident	DINT	Unit ID
90x1:0	Slot x: Short circuit	USINT	Number of channels
90x1:01	Channel 0	BOOL	FALSE (Undetected) TRUE (Detected)
...
90x2:0	Slot x: Over ON/OFF counter	USINT	Number of channels
90x2:01	Channel 0	BOOL	FALSE (Undetected) TRUE (Detected)
...
90x3:0	Slot x: Open circuit	USINT	Number of channels
90x3:01	Channel 0	BOOL	FALSE (Undetected) TRUE (Detected)
...
90x4:0	Slot x: Counter	USINT	Number of channels
90x4:01	Channel 0	UDINT	0 to 4294967295
...
90x6:0	Slot x: System error	USINT	8
90x6:01	Pwr output is out of range	BOOL	FALSE (Undetected) TRUE (Detected)
90x6:02	Pwr control is out of range	BOOL	FALSE (Undetected) TRUE (Detected)
90x6:04	Unit disconnection	BOOL	FALSE (Undetected) TRUE (Detected)
90x6:05	Connection error	BOOL	FALSE (Undetected) TRUE (Detected)
90x6:06	Unit registration error	BOOL	FALSE (Undetected) TRUE (Detected)
90x6:07	Memory error	BOOL	FALSE (Undetected) TRUE (Detected)
90x6:08	Parameter read/write error	BOOL	FALSE (Undetected) TRUE (Detected)
90x7:0	Slot x: Error log	USINT	30
90x7:01	Log 0	STRING	□1
...

*: x: Slot No.

*1: Error log indication example is shown below.

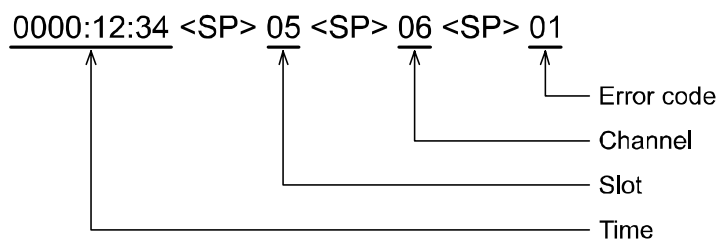

- When the slot and channel are not specified, "--" will be displayed.
- When there is no log, "No error" will be displayed.

Fig. Log format

Table. Error code list

Error code	Content
0	-
1	Short circuit has occurred.
2	Analogue input value has exceeded the lower limit of the range.
3	Analogue input value has exceeded the upper limit of the range.
4	-
5	-
6	Broken wire is detected.
7	Analogue value (value set by user) has exceeded the upper limit.
8	Analogue value (value set by user) has exceeded the lower limit.
9	ON/OFF count has exceeded the set value.
10 to 15	-
16	Power supply voltage level for control and inputs is abnormal.
17	Power supply voltage level for output is abnormal.
18	-
19	Connection error between the units. (When operating)
20	Connection error between the units. (When power is supplied)
21	-
22	System error.
23	Internal component has failed.

Digital input unit (EX600-DX□□), Digital output unit (EX600-DY□□)

Table. Information Data (DX, DY)

Index	Name / Meaning	Type	Value
90x0:0	Slot x: Module identification	USINT	10
90x0:01	Address of the module	UINT	Slot No.
90x0:09	Module PDO group	UINT	2
90x0:0A	Module ident	DINT	Unit ID
90x1:0	Slot x: Short circuit	USINT	Number of channels
90x1:01	Channel 0	BOOL	FALSE (Undetected) TRUE (Detected)
...
90x2:0	Slot x: Over ON/OFF counter	USINT	Number of channels
90x2:01	Channel 0	BOOL	FALSE (Undetected) TRUE (Detected)
...
90x3:0 ^{*1}	Slot x: Open circuit	USINT	Number of channels
90x3:01 ^{*1}	Channel 0	BOOL	FALSE (Undetected) TRUE (Detected)
... ^{*1}
90x4:0	Slot x: Counter	USINT	Number of channels
90x4:01	Channel 0	UDINT	0 to 4294967295
...

*: x: Slot No.

*1: Applicable to the open detecting digital input unit (EX600-DXC1) and digital output unit.

Digital I/O unit (EX600-DM□□)

Table. Information Data (DM)

Index	Name / Meaning	Type	Value
90x0:0	Slot x: Module identification	USINT	10
90x0:01	Address of the module	UINT	Slot No.
90x0:09	Module PDO group	UINT	2
90x0:0A	Module ident	DINT	Unit ID
90x1:0	Slot x: Short circuit	USINT	Number of all channels
90x1:01	Channel 0 (In)	BOOL	FALSE (Undetected) TRUE (Detected)
...
...	Channel 0 (Out)
...
90x2:0	Slot x: Over ON/OFF counter	USINT	Number of all channels
90x2:01	Channel 0 (In)	BOOL	FALSE (Undetected) TRUE (Detected)
...
...	Channel 0 (Out)
...
90x3:0	Slot x: Open circuit	USINT	Number of output channels
90x3:01	Channel 0 (Out)	BOOL	FALSE (Undetected) TRUE (Detected)
...
90x4:0	Slot x: Counter	USINT	Number of all channels
90x4:01	Channel 0 (In)	UDINT	0 to 4294967295
...
...	Channel 0 (Out)
...

*: x: Slot No.

Analogue input unit (EX600-AXA), Analogue output unit (EX600-A Y A)

Table. Information Data (AX, AY)

Index	Name / Meaning	Type	Value
90x0:0	Slot x: Module identification	USINT	10
90x0:01	Address of the module	UINT	Slot No.
90x0:09	Module PDO group	UINT	1
90x0:0A	Module ident	DINT	32 (AX) 34 (AY)
90x1:0	Slot x: Short circuit	USINT	2
90x1:01	Channel 0	BOOL	FALSE (Undetected) TRUE (Detected)
90x1:02	Channel 1	BOOL	FALSE (Undetected) TRUE (Detected)
90x2:0 *1	Slot x: Over range	USINT	2
90x2:01 *1	Channel 0	BOOL	FALSE (Undetected) TRUE (Detected)
90x2:02 *1	Channel 1	BOOL	FALSE (Undetected) TRUE (Detected)
90x3:0 *1	Slot x: Under range	USINT	2
90x3:01 *1	Channel 0	BOOL	FALSE (Undetected) TRUE (Detected)
90x3:02 *1	Channel 1	BOOL	FALSE (Undetected) TRUE (Detected)
90x4:0	Slot x: Over upper limit value	USINT	2
90x4:01	Channel 0	BOOL	FALSE (Undetected) TRUE (Detected)
90x4:02	Channel 1	BOOL	FALSE (Undetected) TRUE (Detected)
90x5:0	Slot x: Under lower limit value	USINT	2
90x5:01	Channel 0	BOOL	FALSE (Undetected) TRUE (Detected)
90x5:02	Channel 1	BOOL	FALSE (Undetected) TRUE (Detected)

*: x: Slot No.

*1: Applicable to the analogue input unit.

Analogue I/O unit (EX600-AMB)

Table. Information Data (AM)

Index	Name / Meaning	Type	Value
90x0:0	Slot x: Module identification	USINT	10
90x0:01	Address of the module	UINT	Slot No.
90x0:09	Module PDO group	UINT	1
90x0:0A	Module ident	DINT	35
90x1:0	Slot x: Short circuit	USINT	4
90x1:01	Channel 0	BOOL	FALSE (Undetected) TRUE (Detected)
...
90x2:0	Slot x: Over range	USINT	2
90x2:01	Channel 0	BOOL	FALSE (Undetected) TRUE (Detected)
90x2:02	Channel 1	BOOL	FALSE (Undetected) TRUE (Detected)
90x3:0	Slot x: Under range	USINT	2
90x3:01	Channel 0	BOOL	FALSE (Undetected) TRUE (Detected)
90x3:02	Channel 1	BOOL	FALSE (Undetected) TRUE (Detected)
90x4:0	Slot x: Over upper limit value	USINT	4
90x4:01	Channel 0	BOOL	FALSE (Undetected) TRUE (Detected)
...
90x5:0	Slot x: Under lower limit value	USINT	4
90x5:01	Channel 0	BOOL	FALSE (Undetected) TRUE (Detected)
...

*: x: Slot No.

*: Channel 0 and 1 indicate analogue input, and Channel 2 and 3 indicate analogue output.

•Diagnostic data

Table. Information Data (Diag.)

Index	Name / Meaning	Type	Value
90A0:0	Diag.: Module identification	USINT	10
90A0:01	Address of the module	UINT	10
90A0:09	Module PDO group	UINT	0
90A0:0A	Module ident	DINT	256 or 257

•Modular Device Profile

Table. Modular Device Profile

Index	Name / Meaning	Type	Value
F000:0	Modular Device Profile / Length of this object	USINT	2
F000:01	Module Index Distance / Module Index Distance between two modules (maximum number of objects per module and area.)	UINT	0x0010 (16dec)
F000:02	Maximum Number of Modules	UINT	0x000B (11dec)

•Module Ident List of the Configured Modules

Table. Module Ident List of the Configured Modules

Index	Name / Meaning	Type	Value
F030:0	Module List / Length of this object	USINT	11
F030:01	Subindex 001 / Module ident for Connected Unit 1	UINT	Unit ID
...
F030:0A	Subindex 010 / Module ident for Connected Unit 10	UINT	0 or unit ID
F030:0B	Subindex 011 / Module ident for Diagnostic Data	UINT	0 or 256 or 257

•Module Ident List of Detected Modules

Table. Module Ident List of Detected Modules

Index	Name / Meaning	Type	Value
F050:0	Module List / Length of this object	USINT	11
F050:01	Subindex 001 / Module ident for Connected Unit 1	UINT	Unit ID
...
F050:0A	Subindex 010 / Module ident for Connected Unit 10	UINT	0 or unit ID
F050:0B	Subindex 011 / Module ident for Diagnostic Data	UINT	0 or 256 or 257

- Example of how to set parameters
 - Complete the EX600 configuration.
 - After selecting [Box1 (EX600-SEC*)] in (1), select [CoE-Online] tab (2), then press [Advanced] button.

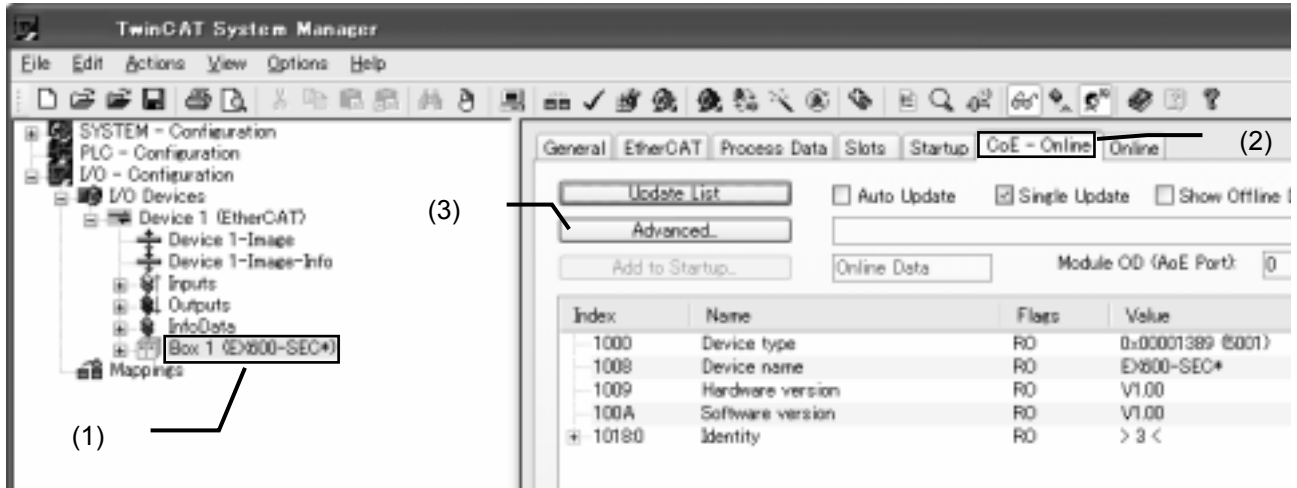

- Select [All Objects] (4) on the [Advanced Settings] screen, and press [OK] button (5).

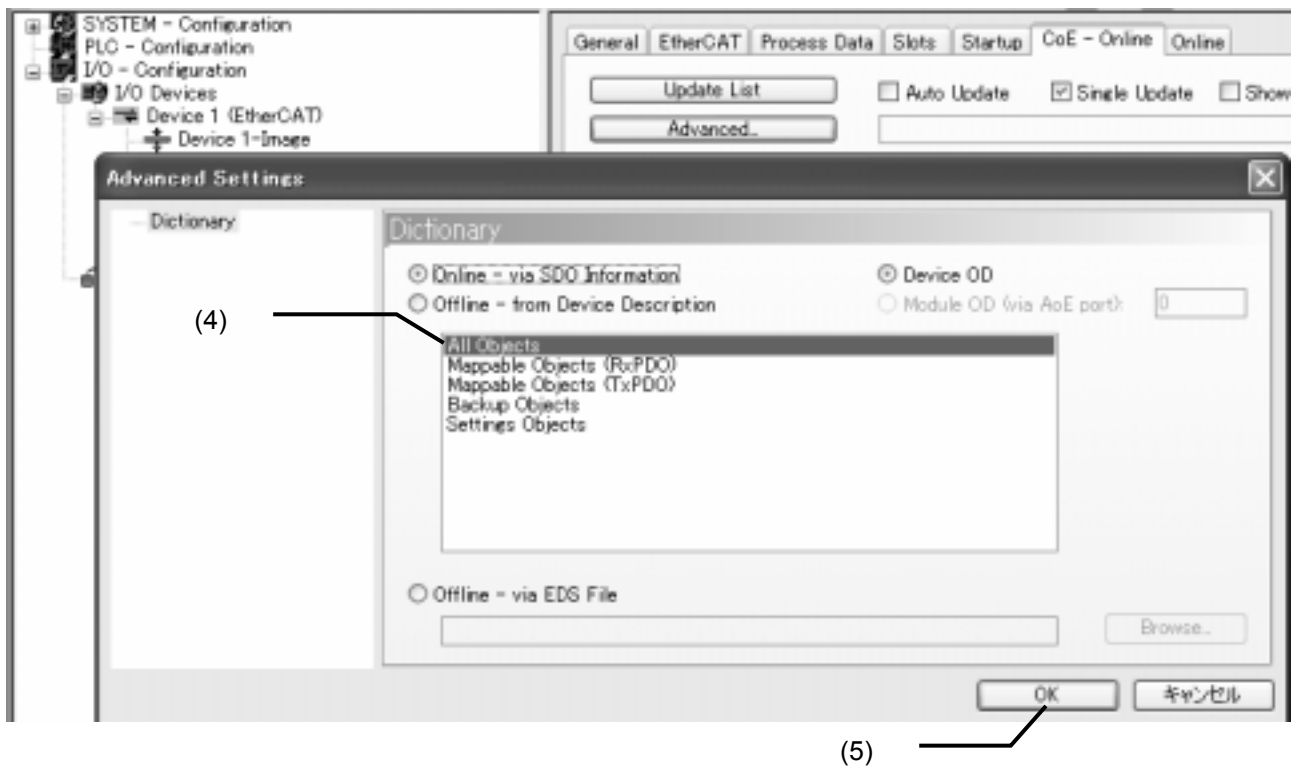

- Object Dictionary will be displayed (6).

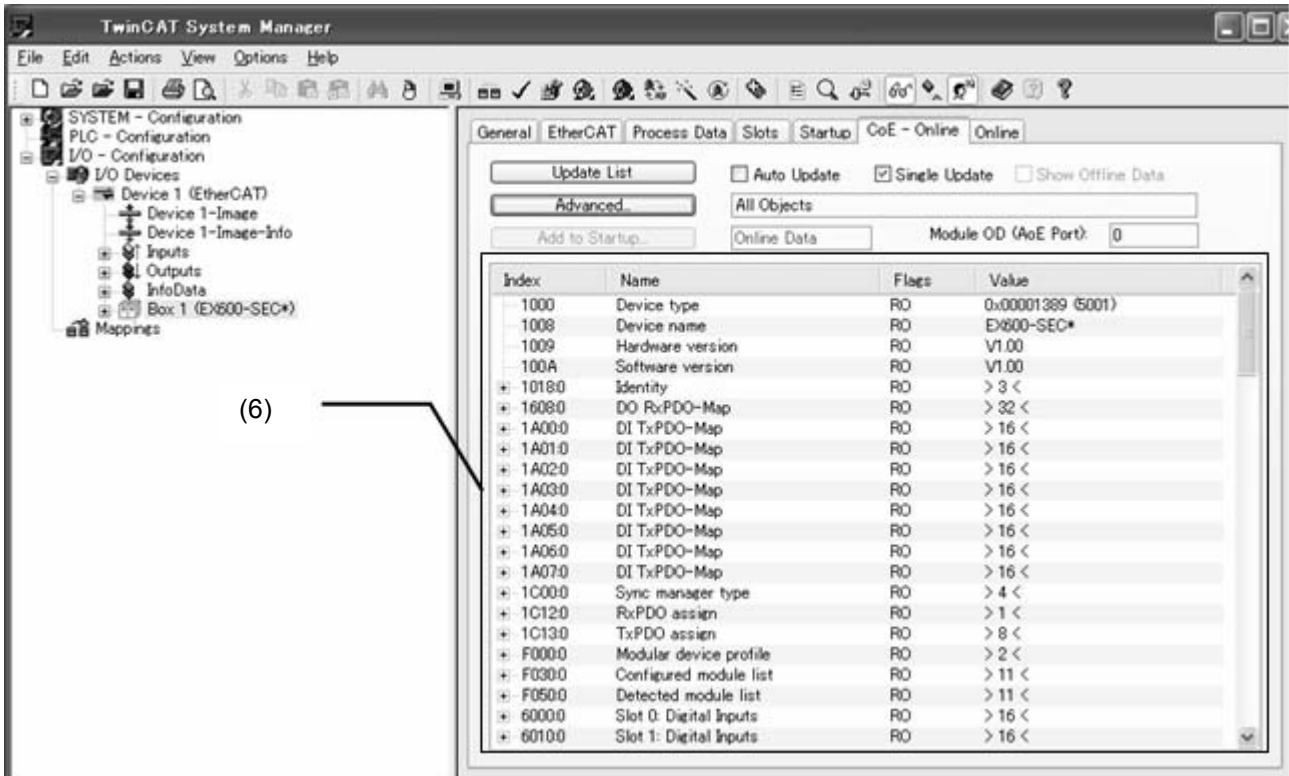

- Index 8011:0 (7) shows the unit parameter of the Digital Inputs Unit of Slot 1.
- Value of the Inrush current filter (8) is in the Disable (0) state.
- Set Value Dialog (9) will be displayed by double-clicking the Value of Inrush current filter (8).
- Parameter can be changed by changing the Enum to Enable (1) and pressing the [OK] button.

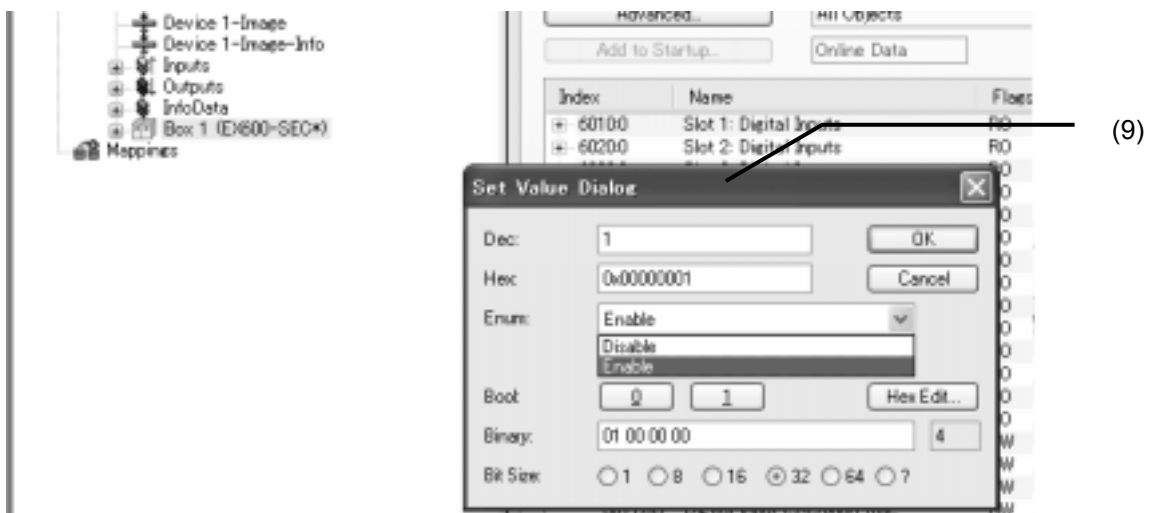
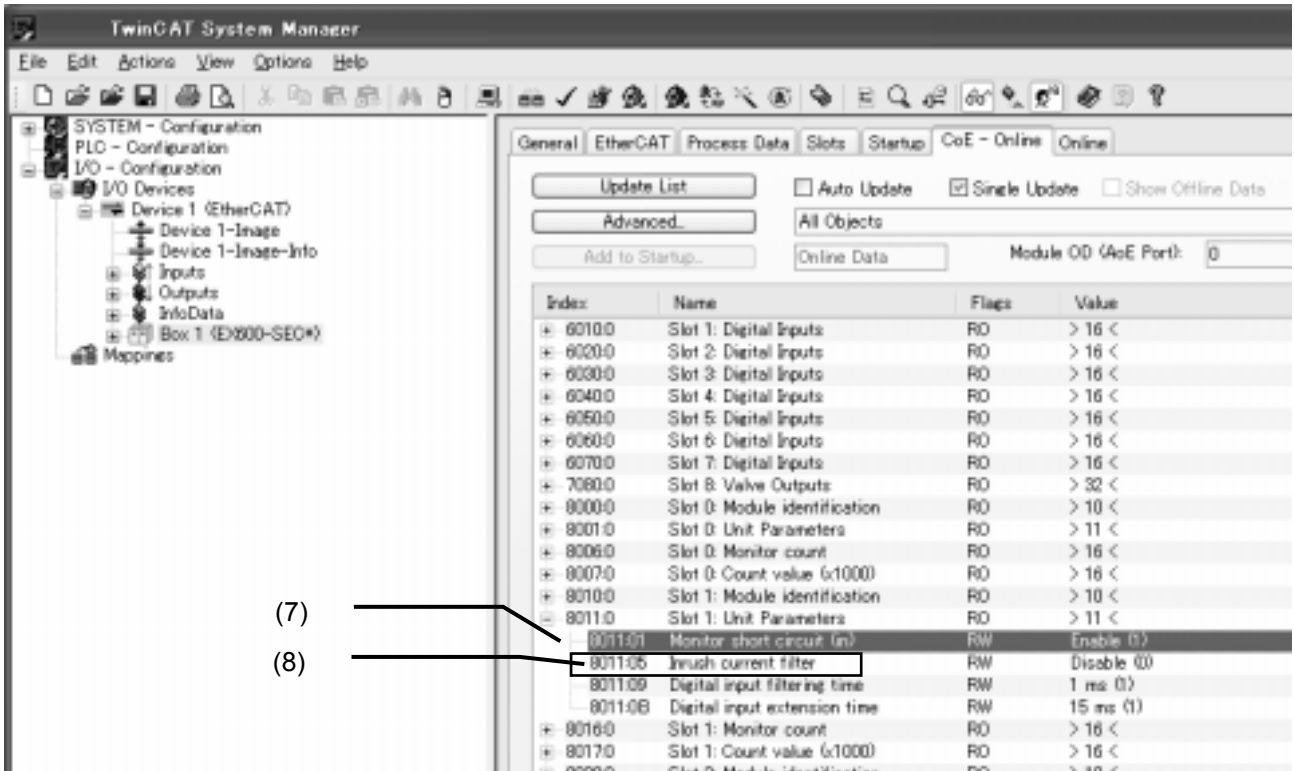

Accessories

For the selection of accessories, refer to the catalog.

(1) Valve plate

EX600-ZMV1

Enclosed parts: Round head screw (M4 x 6), 2 pcs.

Round head screw (M3 x 8), 4 pcs.

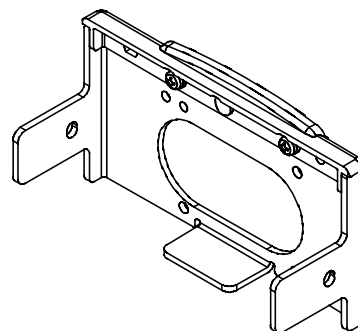

EX600-ZMV2 (Specified for SY series)

Enclosed parts: Round head screw (M4 x 6), 2 pcs.

Round head screw (M3 x 8), 4 pcs.

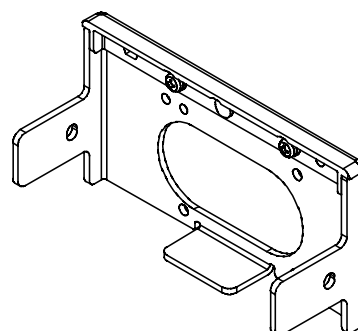

(2) End plate bracket

EX600-ZMA2

Enclosed parts: Round head screw (M4 x 20), 1 pc.

P tight screw (4 x 14), 2 pcs.

EX600-ZMA3 (Specified for SY series)

Enclosed parts: Round head screw (M4 x 20) with washer, 1 pc.

P tight screw (4 x 14), 2 pcs.

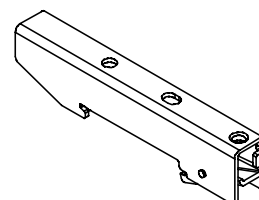

(3) Intermediate reinforcing brace

EX600-ZMB1...for direct mounting

Enclosed parts: Round head screw (M4 x 5), 2 pcs.

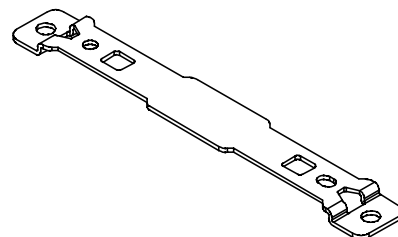

EX600-ZMB2...for DIN rail mounting

Enclosed parts: Round head screw (M4 x 6), 2 pcs.

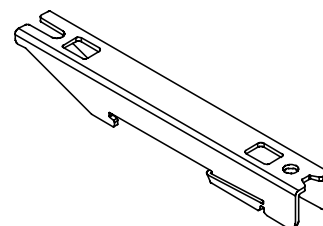

- (4) Seal cap (10 pcs.)
EX9-AWES...for M8
EX9-AWTS...for M12

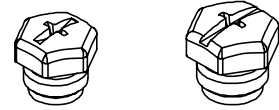

- (5) Marker (1 sheet, 88 pcs.)
EX600-ZT1

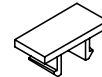

- (6) Y Junction connector
PCA-1557785 2 x M12 (5 pin) – M12 (5 pin)

- (7) Assembled type connector
PCA-1578078 for power supply, 7/8 inch, Plug, Cable O.D. 12 to 14 mm
PCA-1578081 for power supply, 7/8 inch, Socket, Cable O.D. 12 to 14 mm
PCA-1446553 for communication EtherCAT, Plug
PCA-1557730 M8 (3 pin), Plug
PCA-1557743 M12 (4 pin), Plug, for AWG26 to AWG22, SPEEDCON compatible
PCA-1557756 M12 (4 pin), Plug, for AWG22 to AWG18, SPEEDCON compatible

- (8) Power supply cable
PCA-1558810 Cable with 7/8 inch connector, Socket, Straight 2 m
PCA-1558823 Cable with 7/8 inch connector, Socket, Straight 6 m
PCA-1558836 Cable with 7/8 inch connector, Socket, Right angle 2 m
PCA-1558849 Cable with 7/8 inch connector, Socket, Right angle 6 m
PCA-1564927 Cable with M12 connector, B code, Socket, Straight 2 m, SPEEDCON compatible
PCA-1564930 Cable with M12 connector, B code, Socket, Straight 6 m, SPEEDCON compatible
PCA-1564943 Cable with M12 connector, B code, Socket, Right angle 2 m, SPEEDCON compatible
PCA-1564969 Cable with M12 connector, B code, Socket, Right angle 6 m, SPEEDCON compatible

- (9) EtherCAT communication cable
PCA-1446566 Cable with M12 connector, D code, Plug, Straight 5 m, SPEEDCON compatible

- (10) Connector extension cable
PCA-1557769 M12 (4 pin), Straight 3 m, SPEEDCON compatible
PCA-1557772 M8 (3 pin), Straight 3 m

Revision history

SMC Corporation

4-14-1, Sotokanda, Chiyoda-ku, Tokyo 101-0021 JAPAN

Tel: +81 3 5207 8249 Fax: +81 3 5298 5362

URL <http://www.smcworld.com>

Note: Specifications are subject to change without prior notice and any obligation on the part of the manufacturer.
EtherCAT[®] is registered trademark and patented technology, licensed by Beckhoff Automation GmbH, Germany.
TwinCAT[®] is registered trademark and patented technology, licensed by Beckhoff Automation GmbH, Germany.
© 2011 SMC Corporation All Rights Reserved

