



Operation Manual

Original Instructions

Thermo-Chiller

<i>HRZ001-L</i>	<i>HRZ002-L</i>	<i>HRZ004-L</i>	<i>HRZ008-L</i>
<i>HRZ001-L1</i>	<i>HRZ002-L1</i>	<i>HRZ004-L1</i>	<i>HRZ008-L1</i>
<i>HRZ001-L2</i>	<i>HRZ002-L2</i>	<i>HRZ004-L2</i>	<i>HRZ008-L2</i>
<i>HRZ001-H</i>	<i>HRZ002-H</i>	<i>HRZ004-H</i>	<i>HRZ008-H</i>
<i>HRZ001-H1</i>	<i>HRZ002-H1</i>	<i>HRZ004-H1</i>	<i>HRZ008-H1</i>
<i>HRZ002-W</i>	<i>HRZ008-W</i>	<i>HRZ002-W1</i>	<i>HRZ008-W1</i>
<i>HRZ010-WS</i>	<i>HRZ010-W1S</i>	<i>HRZ010-W2S</i>	

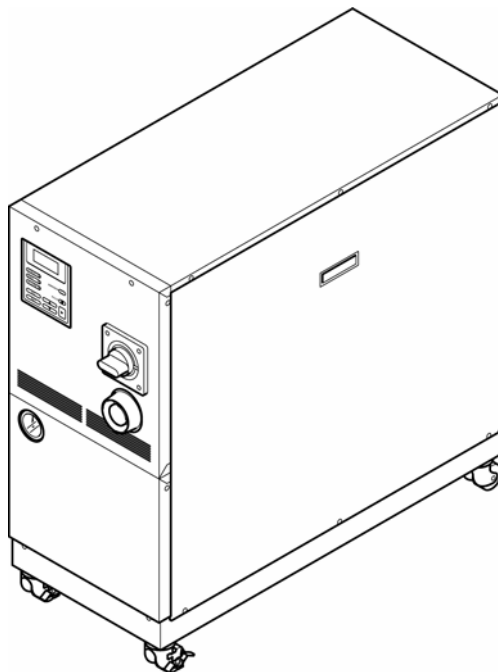

Save This Manual Carefully for Use at Any Time

To the Customers

Thank you for purchasing our THERMO CHILLER HRZ Series (hereinafter called “This system”).

For the long-term, safe use of this system, be sure to read and understand this manual thoroughly before performing operation of this system.

- Warnings and precautions defined in this manual shall be observed.
- This manual provides the explanations of the installation and operation of this system. Only those who have thorough understanding of the fundamental operating procedure or have basic knowledge and skills of handling industrial equipment for the installation and operation of this system are qualified to perform installation and operation.
- The contents of this manual and related documents supplied with this system shall be neither regarded as a provision of the contract nor utilized to correct or modify the existing agreements, commitments and relations.
- Copying, duplicating or transferring any part of or whole contents of this manual without the prior written consent of SMC Corporation is strictly prohibited.
- The Service Manual is supplied in addition to this manual and provides the explanations of the inspection, troubleshooting, and in-depth remedies of this system. The Service Manual is intended for service personnel that completed service training SMC provides. Only those who fall under the above condition are allowed to perform maintenance and repair of this system with the use of the Service Manual.

Note: The contents of this manual are subject to change without notice.

SMC Corporation

Akihabara UDX 15F,
4-14-1, Sotokanda, Chiyoda-ku, Tokyo 101-0021, JAPAN
Phone: +81 3 5207 8249 Fax: +81 3 5298 5362
URL <http://www.smcworld.com>

Table of Contents

Chapter 1 Safety	1-1
1.1 Before Using this System	1-1
1.2 Danger, Warning, and Caution Used in This Manual	1-1
1.2.1 Hazard Levels	1-1
1.2.2 Definitions of “Serious injury” and “Minor injury”	1-1
1.2.3 Symbols.....	1-1
1.3 Hazard Warning Label	1-1
1.3.1 Type of hazard warning label	1-1
1.3.2 Location of hazard warning label	1-1
1.4 Location of Model Label	1-1
1.5 Safety Measures	1-1
1.5.1 Safety Precautions	1-1
1.5.2 Safety Interlock system	1-1
1.5.3 Lockout/Tagout	1-1
1.5.4 Protective equipment.....	1-1
1.6 Emergency Measures	1-1
1.6.1 Emergency off [EMO] switch	1-1
1.7 Waste Disposal	1-1
1.7.1 Disposal of refrigerant and compressor oil.....	1-1
1.7.2 Circulating fluid disposal.....	1-1
1.7.3 System disposal	1-1
1.8 Material Safety Data Sheet (MSDS)	1-1
Chapter 2 Name of Each Section	2-1
2.1 Name of Each Section (1)	2-1
2.2 Name of Each Section (2)	2-1
Chapter 3 Transporting and Installation	3-1
3.1 Transporting	3-1
3.1.1 Transporting with forklift	3-1
3.1.2 Transporting with caster	3-1
3.2 Installation	3-1
3.2.1 Installation conditions	3-1
3.2.2 Installation location and maintenance work area	3-1
3.3 Procedure for Installation	3-1
3.3.1 Installation	3-1
3.3.2 Procedure for system securing (1)	3-1
3.3.3 Procedure for system securing (2)	3-1
3.3.4 Wiring installation	3-1

3.3.5	Procedures for wiring installation.....	3-1
3.3.6	Installation of circulating fluid and facility water piping.....	3-1
Chapter 4 System Startup and Shutdown		4-1
4.1	Pre-check.....	4-1
4.1.1	Installation condition	4-1
4.1.2	Cable connection	4-1
4.1.3	Installation of circulating fluid and facility water piping.....	4-1
4.1.4	Operating signal from your system.....	4-1
4.1.5	Check emergency off [EMO] switch	4-1
4.2	Opening of Facility water Valve.....	4-1
4.3	Supply of Circulating Fluid	4-1
4.3.1	Preparation of circulating fluid	4-1
4.3.2	Supply of circulating fluid.....	4-1
4.4	Requirement for System Startup.....	4-1
4.4.1	Turning ON power.....	4-1
4.4.2	Circulating fluid temperature setting.....	4-1
4.5	System Startup and Shutdown	4-1
4.5.1	System startup.....	4-1
4.5.2	System shutdown	4-1
Chapter 5 System Operation.....		5-1
5.1	Operation Display Panel.....	5-1
5.2	Flow Chart of Operation Screen	5-1
5.3	Operation Screen	5-1
5.3.1	Model Indication screen.....	5-1
5.3.2	Status screen 1	5-1
5.3.3	Status screen 2	5-1
5.3.4	Status screen 3	5-1
5.3.5	Status screen 4	5-1
5.3.6	Menu screen	5-1
5.3.7	Setting screen.....	5-1
5.3.8	Mode Selection screen	5-1
5.3.9	Initial Setting screen	5-1
5.3.10	Maintenance screen	5-1
5.3.11	Option screen	5-1
5.3.12	Alarm Display screen.....	5-1
5.3.13	System Information screen.....	5-1
5.4	Examples of System Operation.....	5-1
5.4.1	Example 1: Circulating fluid set temperature is changed from 23.0°C to 34.1°C.....	5-1
5.4.2	Example 2: Communication mode is switched from “DIO REMOTE” to “LOCAL”	5-1

5.4.3	Example 3: Alarm signal of contact signal is changed from “N/A” to “ALARM1”.	5-1
Chapter 6 Error Message and Troubleshooting		6-1
6.1	Error Message	6-1
6.2	Troubleshooting	6-1
Chapter 7 System Maintenance		7-1
7.1	Water Quality Management	7-1
7.2	Inspection and Cleaning	7-1
7.2.1	Daily inspection	7-1
7.2.2	Quarterly inspection	7-1
7.3	Storage	7-1
7.3.1	Draining of circulating fluid out of tank	7-1
7.3.2	Draining of facility water	7-1
7.4	Periodic Replacement Parts	7-1
Chapter 8 Appendix		8-1
8.1	Specification	8-1
8.1.1	System specification	8-1
8.1.2	Communication specification	8-1
8.1.3	Alarm signal selection	8-1
8.2	Outer Dimensions	8-1
8.2.1	Part 1	8-1
8.2.2	Part 2	8-1
8.2.3	Part 3	8-1
8.3	Flow Chart	8-1
8.3.1	Part 1	8-1
8.3.2	Part 2	8-1
8.4	Offset Function	8-1
8.4.1	Example of offset function	8-1
8.5	BAND/READY function	8-1
8.6	Anchor Bolt Mounting Position	8-1
8.6.1	Part 1	8-1
8.6.2	Part 2	8-1
8.7	Compliance	8-1
8.8	Thermo Chiller Daily Inspection Sheet	8-1

Chapter 1 Safety



Be sure to read and understand the important precautions defined in this manual thoroughly prior to system use.

1.1 Before Using this System

- This "Safety" chapter describes the safety-related items that users should be aware of upon handling this system.
- This system, which is operated under high voltage, is outfitted with the parts that cause a rise or drop in temperature and rotating parts when it is in action, All personnel who work with or around this system are required to thoroughly read and understand the safety-related items in this manual prior to working with or around this system.
- This manual is not intended to be used as a manual for comprehensive safety and hygiene education. Such a manual should be provided by a safety training manager.
- All personnel who work on or around this system are to have proper training and education on dangers specific to this system and safety measures against potential hazards.
- A safety manager is responsible for observing safety standards. Operators and maintainers, however, are to have individual responsibilities for complying with the safety standard in his/her daily work.
- Operators and maintainers must individually take account of safety and assure a proper working area and working environment.
- The relevant personnel must receive proper safety education prior to work training on this system. Otherwise, personnel may be exposed to hazards. Never conduct work training without giving proper consideration to safety.
- Save this manual at a designated place for reference when necessary.

1.2 Danger, Warning, and Caution Used in This Manual

1.2.1 Hazard Levels

This system is designed with its first priority being the safety of workers and the prevention of system damage. This manual classifies the risks into the following three categories according to the severity and level of the hazard; Danger, Warning, and Caution. Read the statements carefully, thoroughly understand them before operating this system.

DANGER, WARNING and CAUTION signs are in order according to hazard severity (DANGER > WARNING > CAUTION). See below for the details.

 DANGER
"DANGER" denotes that there is an imminent hazard which will cause serious personal injury or death during operation.

 WARNING
"WARNING" denotes that there is a hazard which may cause serious personal injury or death during operation.

 CAUTION
"CAUTION" denotes that there is a hazard which may cause minor personal injury during operation.

CAUTION
"CAUTION" without an exclamation symbol denotes that there is a hazard which may cause damage or failure of this system, facility, or devices.

[Tips]

Tips are provided when there is information personnel are required to be aware of for system operation and maintenance. If the task carries useful information, the relevant tips are given as well.

1.2.2 Definitions of “Serious injury” and “Minor injury”

■ “Serious injury”

This term describes injuries such as loss of eyesight, wound, burns, frostbite, electric shock, fracture, and toxication that leave aftereffects, and/or injury requiring hospitalization and/or prolonged staying in a hospital.

■ “Minor injury”

This term describes injuries that do not require hospitalization or prolonged staying in a hospital (injuries other than “serious injuries” described above).

1.2.3 Symbols

This manual provides the following symbols in addition to “Danger”, “Warning”, and “Caution” to present the warning details in easy-to-understand manner.

■ Symbol of electrical hazard



This symbol warns you of potential electrical shock.

■ Symbol of heat hazard



This symbol warns you of potential burns.

■ Symbol of low temperature hazard



This symbol warns you of potential frostbite.

■ Symbol of “Don’ts”



This symbol denotes “Don’t” item which you must not do in operation of this system.

■ Symbol of “Required Action”



This symbol denotes the “obligation” items which you must follow in operation of this system.

1.3 Hazard Warning Label

The hazard warning labels are applied to the sections of this system where potential hazards are present during system operation and maintenance.

The hazard warning labels are in appropriate sizes and colors to get attention of the operator. They contain symbols in addition to the descriptions of warnings.

1.3.1 Type of hazard warning label

The hazard warning labels affixed on this system are listed below.

■ Labels of high voltage hazard

[High voltage hazard]

This warning label is affixed on the part isolated with the cover panel of the system panel in which high voltage is applied.
 Do not remove cover panels that are not designated in this manual.



Figure 1-1 Hazard warning label No.1



Figure 1-2 Hazard warning label No.2

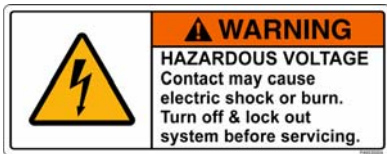

Figure 1-3 Hazard warning label No.3

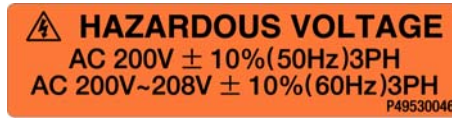

Figure 1-4 Hazard warning label No.4

■ Labels of hot/cold surface hazard

[Hot/cold surface hazard]

This warning label is affixed on the surface that is at high or low temperatures carrying potential burns (or frostbite) if touched. Residual heat may cause burns despite the power being turned OFF. Be sure of the surface reaching room temperature before work.



Figure 1-5 Hazard warning label No.5



Figure 1-6 Hazard warning label No.6

1.3.2 Location of hazard warning label

⚠ WARNING



Do not peel off or deface the hazard warning labels.

⚠ WARNING



- Confirm the locations of the hazard warning labels.
- Read the contents of the hazard warning labels carefully and keep them in mind.

⚠ WARNING



Users are NOT allowed to change the locations of the hazard warning labels. Make sure to affix a new label to exactly the same location of the replaced label upon replacement of the peeled off or worn out label.

■ High voltage hazard

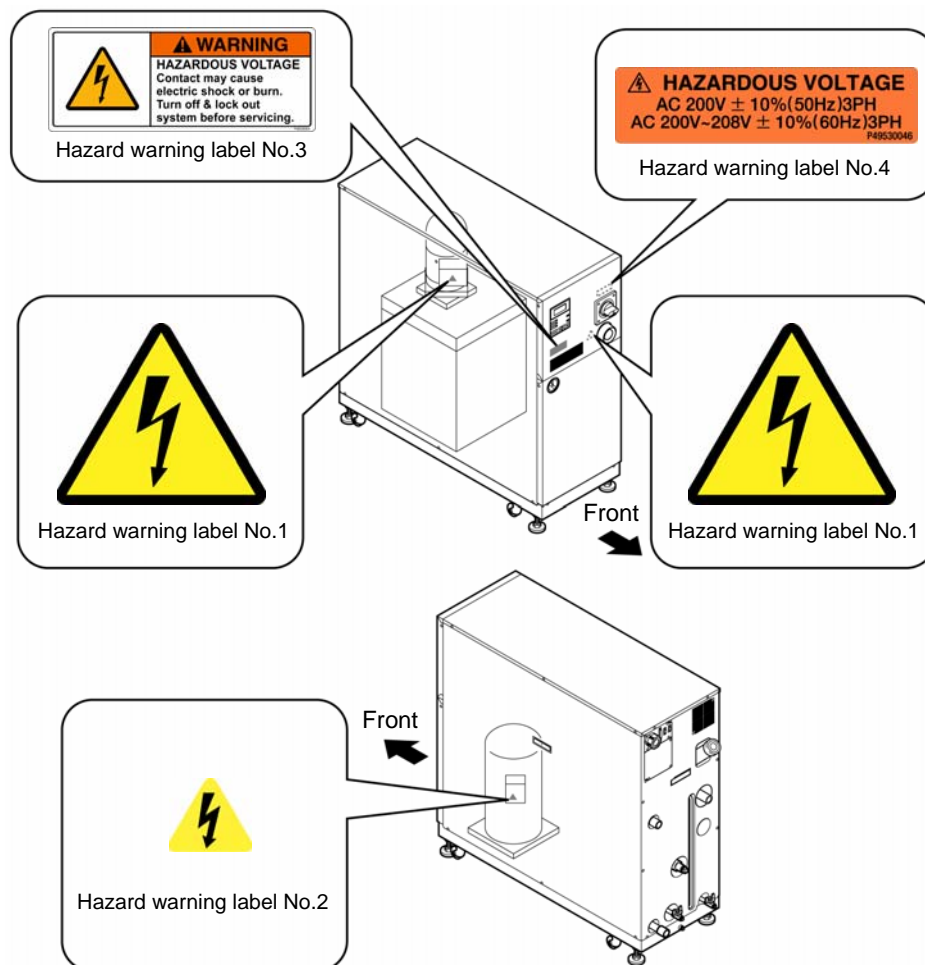

Figure 1-7 High Voltage Hazard

1.4 Location of Model Label

Information on your system such as Serial No. and Model No. need to be furnished when you contact the store you purchased from. Serial No. and model No. are listed on the label as shown below.

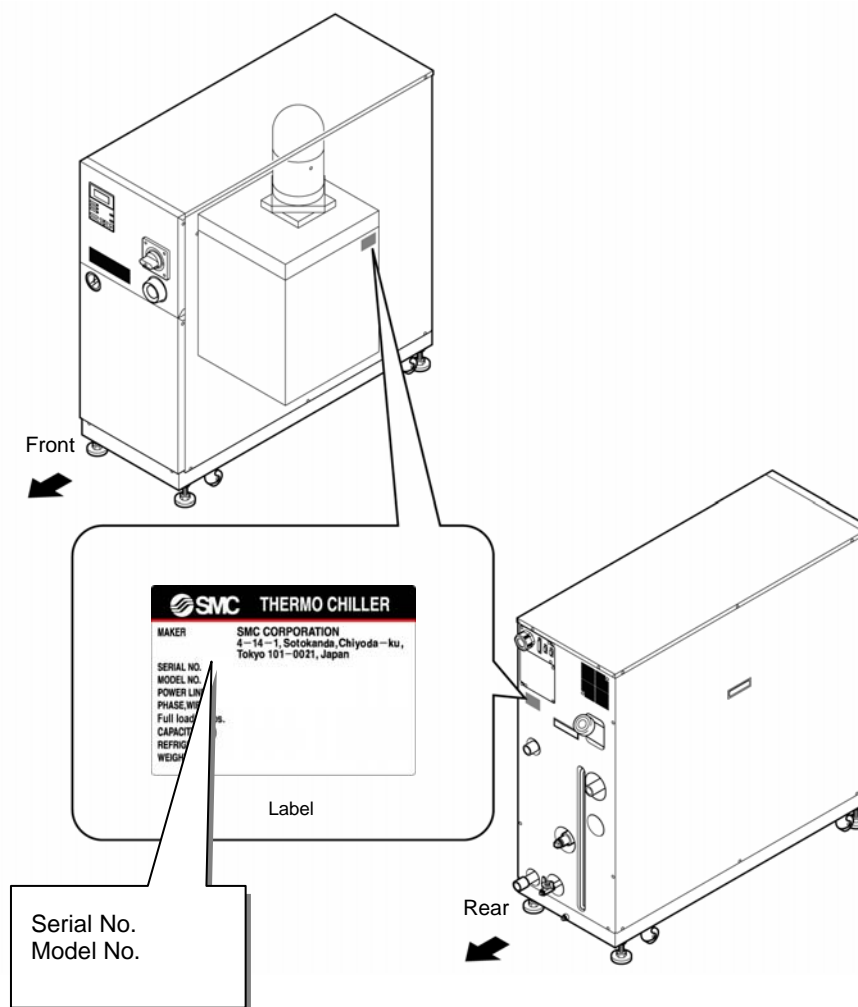

Figure 1-9 Location of Model Label

1.5 Safety Measures

1.5.1 Safety Precautions

While this system is protected by various safety measures including the safety interlocks, the following basic safety precautions should be observed to assure further safe operations.

WARNING



Follow the following instructions upon operation of this system. Failure to follow the instructions can lead to personal injury or hazardous accidents.

- Read and understand this manual thoroughly before operation of this system.
- Before operating the system during maintenance, inform all personnel who are working in the vicinity of the system to alert them of your action.
- Use appropriate tools and follow proper procedures.
- See “1.5.4 Protective equipment” to wear protective equipment properly.
- Refer to your safety manual for emergency evacuation.
- Use assistance to carry object over 20 kg.
- Check that all parts and screws are returned to the pre-work conditions at the end of work.
- Do not work when intoxicated or feeling ill. Accidents may occur if disregarded.
- Do not remove a panel unless permitted in this manual.

1.5.2 Safety Interlock system

■ Safety Interlock system

The function of the safety interlock system is not only protect personnel by restricting operation that may cause damage to this system or the facility around it but also eliminate the danger relating to safety. This system is outfitted with several interlock functions that are activated when improper operation or hazardous conditions occur. System operation shall be terminated when a safety interlock is activated

An alarm message is displayed on the LCD screen when a safety interlock is activated. See “Chapter 6 Error Message and Troubleshooting” for details on the alarms and remedies or see section “Troubleshooting” in a separate volume of the “Service Manual”.

■ Front panel

System repair may require the removal of the front panel.
The breaker handle operation is available only with the front panel attached.

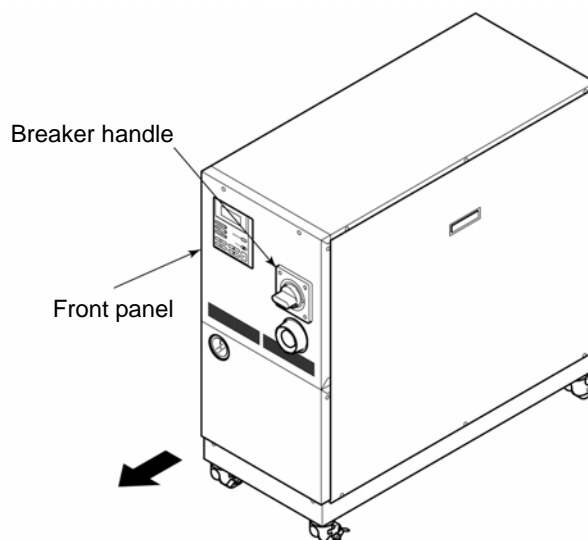

Figure 1-10 Front Panel

1.5.3 Lockout/Tagout

■ Summary

Lockout in this system disables the main breaker operation to prevent electric shocks.

Tagout, to be placed on a locked out main breaker, to prevent improper breaker operation (ON) conducted by other personnel.

See “■ Lockout procedure” in the following pages for practical lockout/tagout.

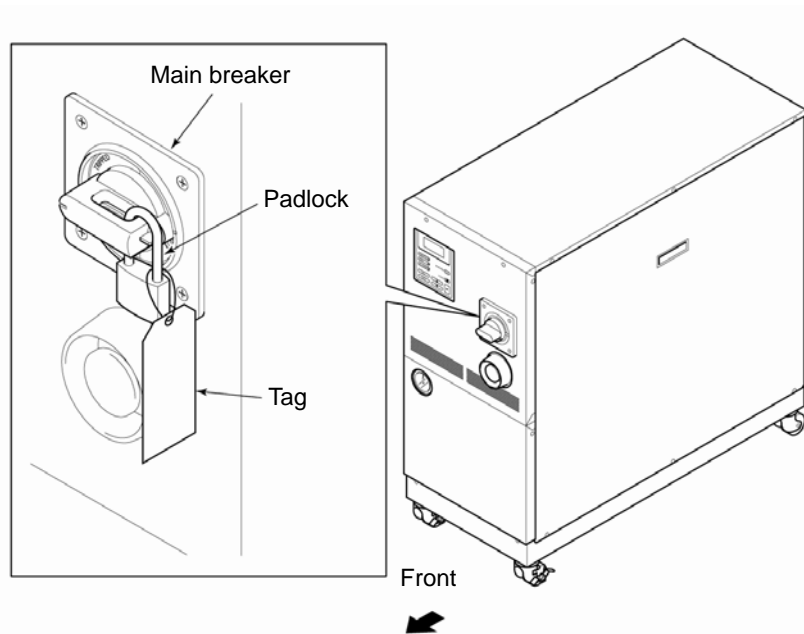

Figure 1-11 Lockout/Tagout

⚠ WARNING



- Those who engage in service of this system should build an awareness of the importance of lockout. Thorough understanding of the procedures defined in this manual are required for system service.
- Lockout is allowed only when the system come to a full stop.
- A supervisor should be appointed to direct all personnel if multiple workers engage in system service.
The supervisor is to perform lockout based on a full understanding of overall process conditions.
- Not only all personnel but new personnel that engage in service of this system should build an awareness of the importance of lockout and obtain thorough understanding of the lockout procedure.
- Any personnel working in an area with high voltage should be assigned with padlocks and tags. The key for the padlock is kept under the responsibility of the supervisor, and lockout release is performed upon completion of work.

■ Lockout procedure

⚠ WARNING



All service personnel must observe the restrictions applied during lockout and are required to perform lockout in accordance with this procedure. No service personnel is allowed to start, energize, or use the locked out system.

1. Turn the breaker handle to 'OFF O'.

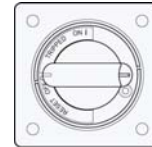

Figure 1-12 Breaker Handle at 'OFF O'

2. Turn the breaker handle to 'RESET'.

- Hold the breaker handle with hand.
The handle turns back to 'OFF O' if released.

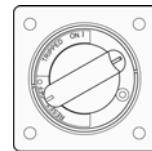

Figure 1-13 Breaker Handle at 'RESET'

3. Push the lock pushing part of the breaker handle, and turn the breaker handle to 'OFF O'.

- The lock mechanism part is to remain opened.

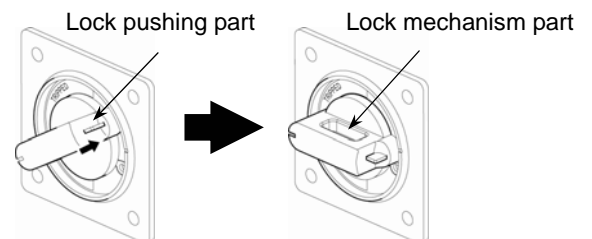

Figure 1-14 Pushing of Lock Mechanism Part

4. Lock the lock mechanism part with the padlock.

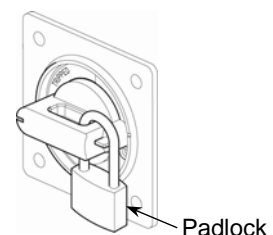

Figure 1-15 Breaker Lock

■ Releasing lockout

1. Remove the padlock from the lock mechanism part.

2. Turn the breaker handle to 'RESET'.

The lock mechanism part is closed.

- The handle turns back to 'OFF O' if released.

1.5.4 Protective equipment

This manual defines protective equipment according to work type.

Wear proper protective equipment as shown below, according to work type.

 WARNING	
	Read and understand the relevant operation manual thoroughly prior to use of protective equipment.

■ **For system transportation, installation and removal**

- Protective footwear
- Protective gloves
- Hard hat

■ **For handling circulating fluid**

- Protective footwear
- Protective gloves
- Protective mask
- Protective apron
- Protective goggles

■ **For system operation**

- Protective footwear
- Protective gloves

1.6 Emergency Measures

1.6.1 Emergency off [EMO] switch

Press the red emergency off [EMO] switch on the front of the system only if the need to shut off the power arises due to emergency such as natural disaster, fire, earthquake or personal injury.

The emergency off [EMO] switch is a large, red mushroom-shaped push button labeled with 'EMO' on it. The system comes to a halt if this button is pressed.

When press the emergency off [EMO] switch, the control power for this system is shut off to bring the system to a stop. The main breaker of this system, however, is designed not to trip, which enables the motor circuit to remain partially energized. "8.1.2 Communication specification" in Chapter 8 Appendix on page 8-5 to view the circuit diagram and see how the EMO switch is interconnected to the system.

Restart of this system is enabled only when this button is reset manually.

■ Location of emergency off [EMO] switch

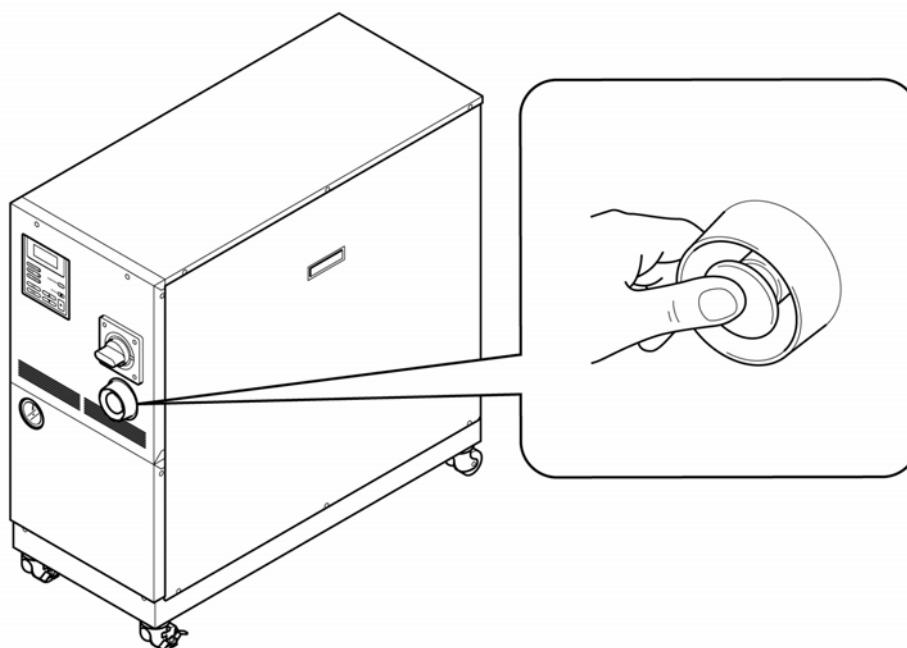

Figure 1-16 Location of Emergency Off [EMO] Switch

■ Reset of emergency off [EMO] switch**⚠ WARNING**

No automatic recovery is applied to the emergency off [EMO] switch. Always eliminate the cause of activating the EMO before resetting. Potential serious accidents may occur if disregarded.

- 1.** Before restarting, always make sure that the cause of the emergency off condition (The reason why the EMO switch was activated) has been eliminated from the power supplies, the system and peripheral equipment.

- 2.** With the cause completely eliminated, turn the emergency off [EMO] switch clockwise to reset.

The EMO button returns to its original position.

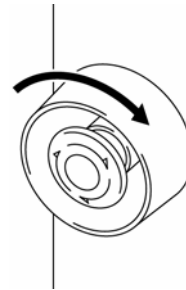

Figure 1-17 Emergency Off [EMO] Switch

⚠ WARNING

When the system is in remote mode, the remote mode is retained despite the power outage. Thus the system operation is to resume as the start signal is issued from your system.

- 3.** The screen then changes from the “Model Indication screen” to “Status screen 1” as power is being restored to the system.

1.7 Waste Disposal

1.7.1 Disposal of refrigerant and compressor oil

HFC- refrigerant and compressor oil are present in this system. When recovering the refrigerant or compressor oil, the precautions provided below should thoroughly be read and understood in advance. If you have any questions or concerns, contact the system supplier.

⚠ WARNING

 Only service personnel or those who are qualified are allowed to open the panel of this system.

⚠ WARNING

 Do not dispose of the compressor oil as domestic garbage. Incineration is permitted only at an authorized incinerator.

⚠ WARNING

 Disposal of the compressor oil must be in accordance with regulations and rules of local authorities.

⚠ WARNING

 The release of refrigerant into the air is prohibited by law. Recover the refrigerant with the “refrigerant recovery system”, and request the specialized waste disposal agency for disposal of the recovered refrigerant.

⚠ WARNING

 Only personnel with proper licensing, who have adequate knowledge and experiences with not only this system but associated equipment are allowed to implement the recovery of the refrigerant and compressor oil.

[Tips]

For the type and quantity of the refrigerant, See “Location of Model Label” on page 1-1.

1.7.2 Circulating fluid disposal

As to the disposal of a circulating fluid (ethylene glycol solution, fluorinated fluid), consign the specialized industrial waste disposal agency with the contents detailed.

1.7.3 System disposal

As to the disposal of this system, consign the specialized industrial waste disposal agency in accordance with local laws and regulations.

1.8 Material Safety Data Sheet (MSDS)

Material Safety Data Sheet (MSDS) is supplied separately. Contact the system supplier if you need the MSDS regarding chemicals used in this system.

For each chemical you purchased, the relevant MSDS is to be obtained under your responsibility. Keep the MSDS along with this manual in the condition that allows all personnel to check the contents anytime to gain the understanding of potential hazards.

Chapter 2 Name of Each Section

2.1 Name of Each Section (1)

HRZ001-L	HRZ002-L	HRZ004-L	
HRZ001-L1	HRZ002-L1	HRZ004-L1	
HRZ001-L2	HRZ002-L2	HRZ004-L2	HRZ008-L2
HRZ001-H	HRZ002-H	HRZ004-H	HRZ008-H
HRZ001-H1	HRZ002-H1	HRZ004-H1	HRZ008-H1
HRZ002-W	HRZ008-W	HRZ002-W1	HRZ008-W1
	HRZ010-WS	HRZ010-W1S	HRZ010-W2S

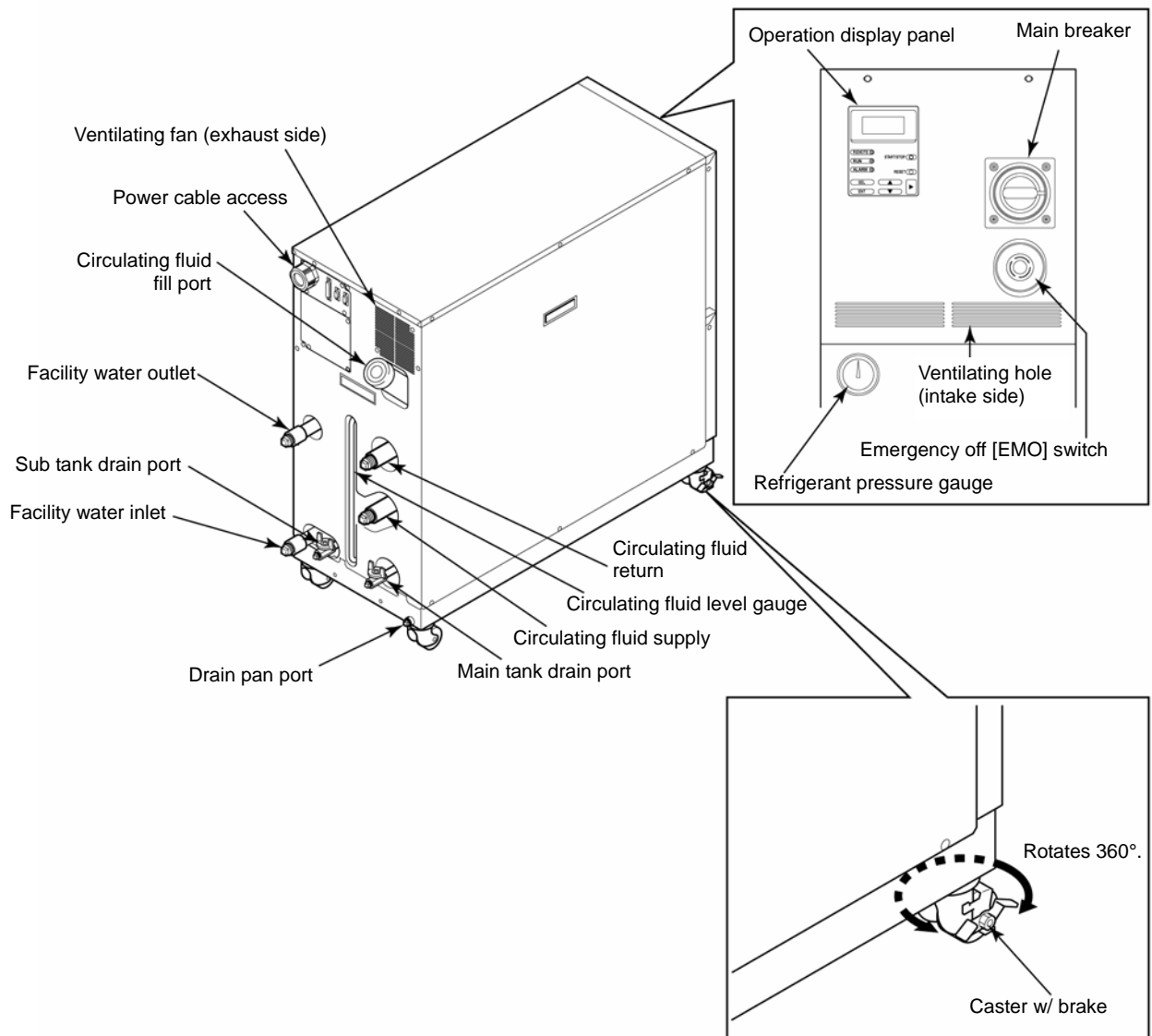

Figure 2-1 Name of Each Section (1)

[Tips]

The front casters (2 pcs.) have built-in brakes. The disengagement of the brakes is required when transporting the system.

2.2 Name of Each Section (2)

HRZ008-L HRZ008-L1

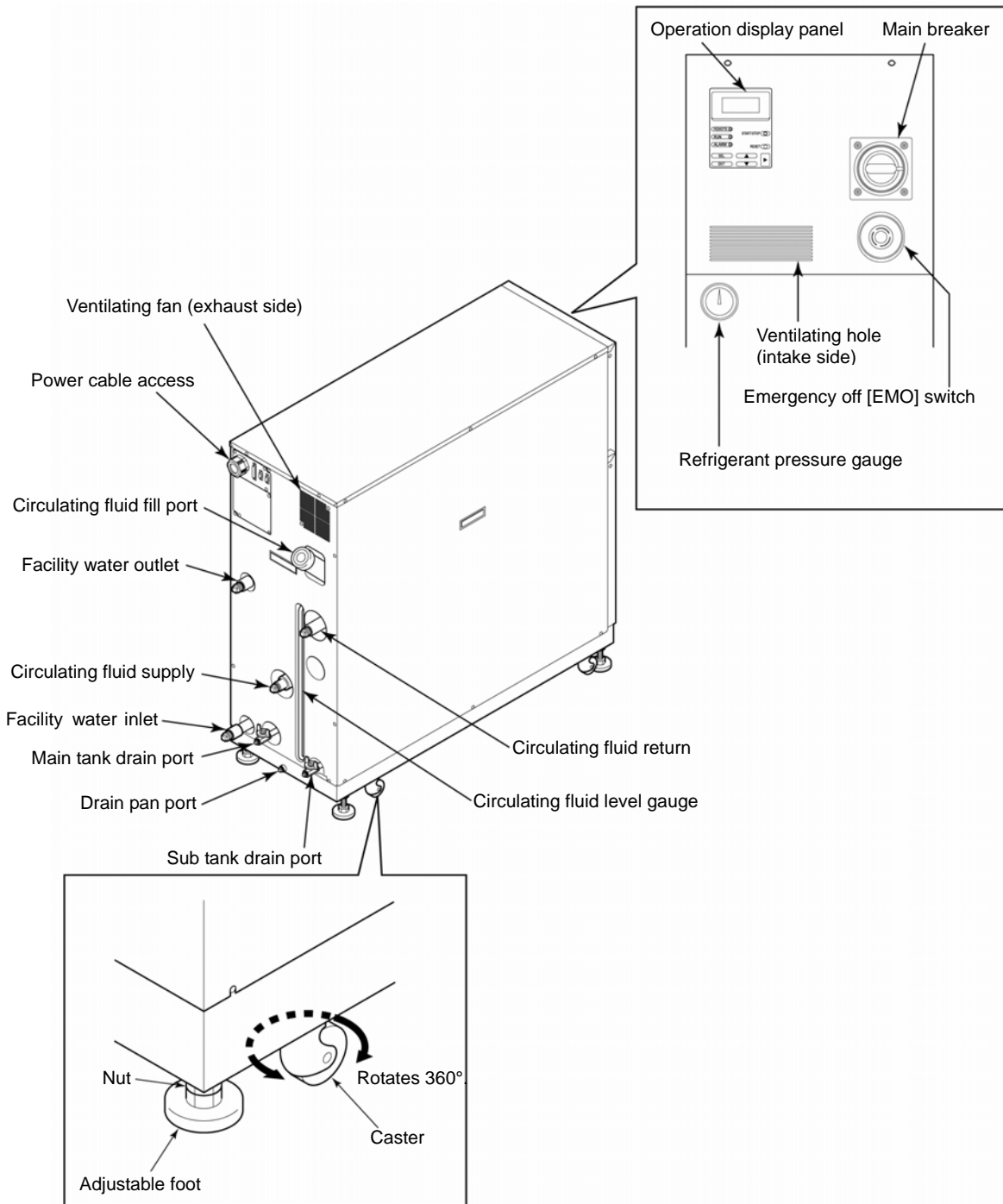

Figure 2-2 Name of Each Section (2)

⚠ CAUTION

When transporting the system with the casters, raise the adjustable feet (4 pcs.) to the highest position and lock them with the nuts. The adjustable foot at the lower position may cause damage to this system and personal injury through contact with the floor or steps during system transport.

Chapter 3 Transporting and Installation

⚠ WARNING



Proper procedure must be followed when using this system. Exercise caution to assure personnel safety during the installation, operation, maintenance, and inspection of the system.

⚠ WARNING



Only personnel, who have adequate knowledge and experiences with not only this system but associated equipment are allowed to perform transport, installation, and maintenance involving potential hazardous task.

3.1 Transporting

This system is heavy, which poses potential danger at transportation. When transporting this system, the following safety precautions should be observed to prevent system damage and breakdown.

⚠ WARNING



For transporting with the forklift, be sure to insert the fork into a designated position, referring to “3.1.1 Transporting with forklift” on page 3-2.

CAUTION



Do not set this system on its side during transportation. Oil in the compressor drains into the refrigerant pipe, which causes lubricant shortages leading to damage to the compressor.

CAUTION



Drain the remaining fluid out of the pipe as much as possible. The remaining fluid may spill if disregarded.

CAUTION



Exercise caution not to damage the panel and piping with the forklift when transporting the system.

3.1.1 Transporting with forklift

⚠ WARNING



- Do not set this system on its side for transportation. Potential damage to this system carrying danger of personnel injury if disregarded.
- Do not insert the fork from the back as well as front.

⚠ WARNING



- This system is heavy, and requires a forklift to safely move it.
- Forklift insertion positions are on either left or right side of this system. Always insert the forks all the way through. Be careful not to hit the casters and adjustable feet.

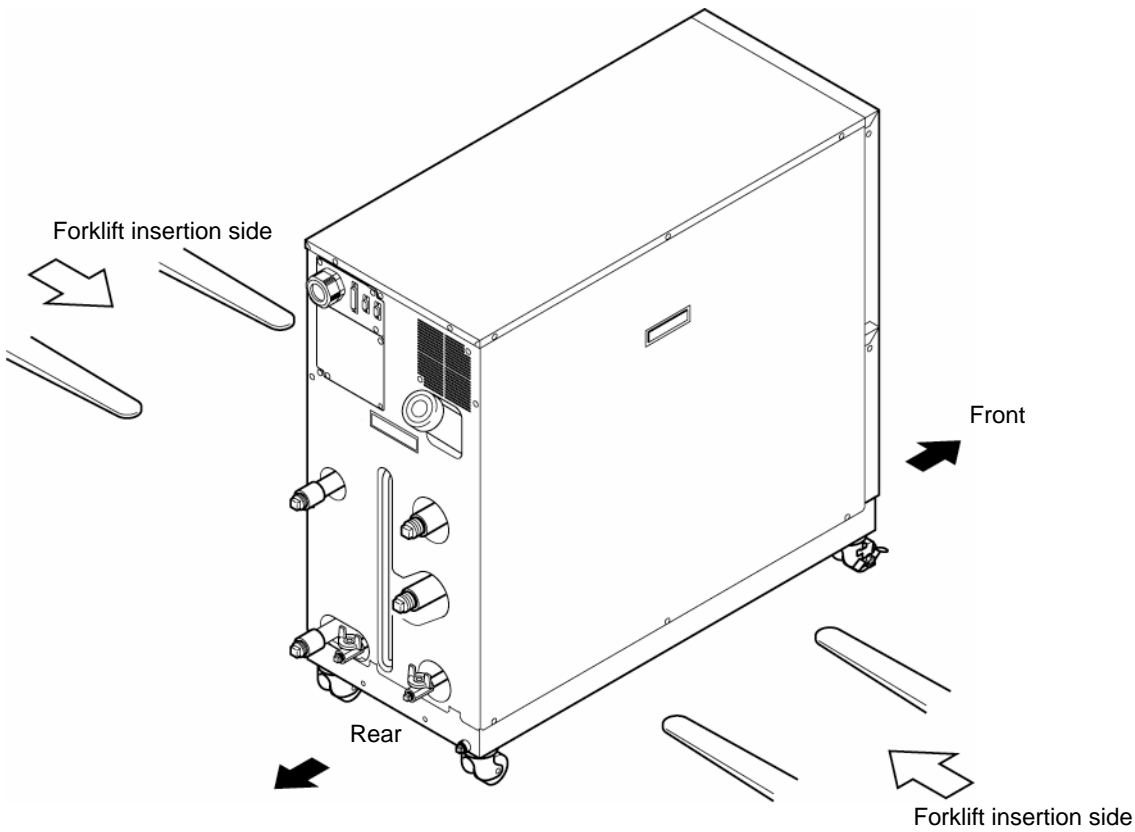

Figure 3-1 Transport with Forklift

3.1.2 Transporting with caster

WARNING



This system is heavy, which requires assistance for this work. Exercise caution and look out for sloped surfaces such as ramps, etc.

CAUTION



Do not grab piping on the back of this system or panel handles when transporting with the casters. Potential damage to piping and panels may occur if disregarded.

3.2 Installation

WARNING



System installation should be kept from areas with the potential of flammable gas leak. Ignition may occur if leaked gas is collected around the system.

WARNING



This system is **NOT** designed for outside use. Potential electric shock, fire and system damage may occur if exposed to rain, water and dust.

CAUTION



This system is to be installed on a level floor that can withstand the weight of this system. Potential water leak and personal injury due to system tipping over may occur if disregarded.

3.2.1 Installation conditions

System installation is not allowed outside or in the conditions described below. Potential system malfunction and damage may occur if disregarded.

Clean room specifications are not applied to this unit. The pump and ventilating fan installed in this unit generate particles.

- Location that is exposed to water vapor, salt water, and oil
- Location that is exposed to dust and powder
- Location that is exposed to corrosive gas, solvent, and flammable gas
- Location that is exposed to direct sun light or radiant heat
- Location where ambient temperature is out of the following range:
 - In operation 10 to 35°C
 - In storage 0 to 50°C (with no water or circulating fluid in piping)
- Location where relative humidity is out of the following range:
 - In operation 30 to 70%
 - In storage 15 to 85%
- Location that is subjected to abrupt changes in temperature
- Location that is subjected to intense electromagnetic noise (intense electric field, intense magnetic field, or surges)
- Location that is subjected to static electricity, or condition that discharges static electricity to the system
- Location that is subjected to strong high frequencies
- Location that is subjected to potential lightning damage
- Location with altitudes of 1000m or higher
- Location that is affected by strong vibrations or impacts
- Condition that applies external force or weight causing the system deformation
- Condition with no adequate space for maintenance as required in the installation site.

3.2.2 Installation location and maintenance work area

This system does not have ventilating hole on the both right and left sides. Although this can be installed directly contacting to walls or devices, installation with maintenance space is recommended. (See “Figure 3-2)

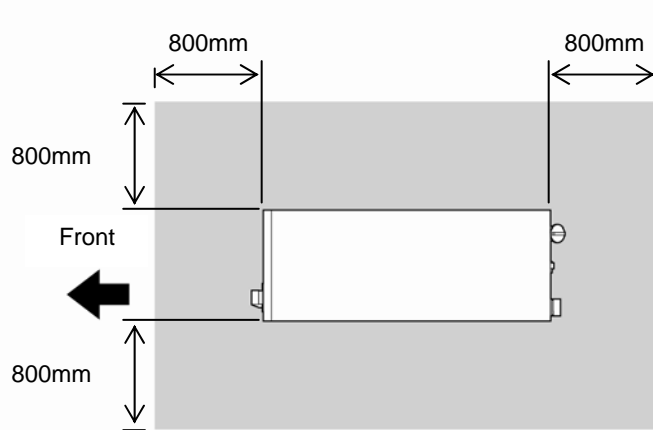

Figure 3-2 Recommended Installation Location

To save space, this system can be installed to allow access only in front and back for daily operation and inspection. For maintenance and repair work, additional access space is required for the left and right side of the system. We recommend a separate repair area, without taking space from installation site, to accommodate the needed extra space.

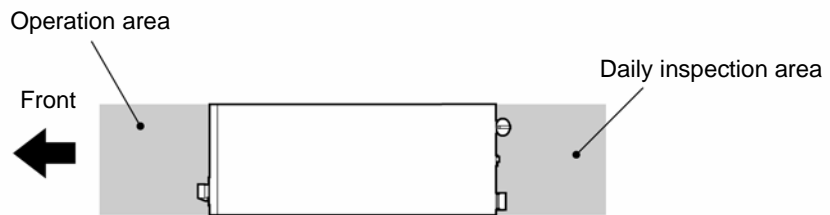

Figure 3-3 Installation Location

3.3 Procedure for Installation

CAUTION
<ul style="list-style-type: none"> ● Anti-seismic bracket is an optional part (except for HRZ008-L, HRZ008-L1), which is required for the installation of this system (HRZ-TK002). ● Preparation of anchor bolts suitable for floor material is your responsibility. M8-anchor bolts (8 pcs.) are required for HRZ008-L and HRZ008-L1, and M12-anchor bolts (4 pcs.) for other models. See “Appendix 8.5 BAND/READY function”

3.3.1 Installation

- System installation should be on a vibration-free stable level plane.
- See “Appendix 8.2 Outer Dimensions” in Chapter 8 on page 8-1 for the dimensions of this system.

3.3.2 Procedure for system securing (1)

HRZ001-L	HRZ002-L	HRZ004-L	
HRZ001-L1	HRZ002-L1	HRZ004-L1	
HRZ001-L2	HRZ002-L2	HRZ004-L2	HRZ008-L2
HRZ001-H	HRZ002-H	HRZ004-H	HRZ008-H
HRZ001-H1	HRZ002-H1	HRZ004-H1	HRZ008-H1
HRZ002-W	HRZ008-W	HRZ002-W1	HRZ008-W1
	HRZ010-WS	HRZ010-W1S	HRZ010-W2S

1. Transfer this system to the installation site.
-
2. Lock the brakes on casters (2 pcs. on the front).
-
3. Using a 13-mm open end wrench, attach the anti-seismic brackets to the front and back.

CAUTION
<p>Drain pan port is assigned to the bottom on the back of this system. Exercise caution not to damage the drain pan port when attaching the anti-seismic bracket.</p>

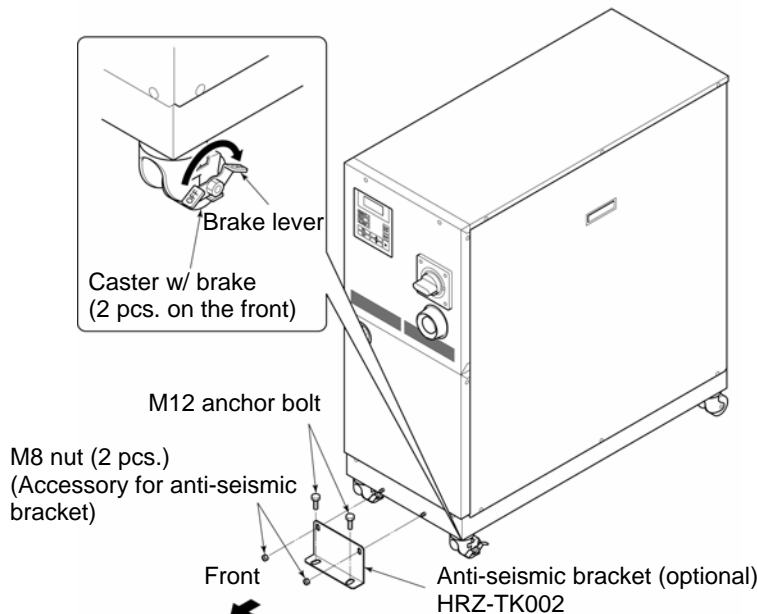

Figure 3-4 Anti-seismic Bracket Attachment

3.3.3 Procedure for system securing (2)

HRZ008-L HRZ008-L1

Adjust and secure the adjustable feet of this system to secure the anti-seismic bracket.

1. Transfer this system to the installation site.

2. Adjust the adjustable foot with a 24-mm open end wrench.

- Level the system (using a leveler) by adjusting the adjustable feet.
- All adjustable feet (4 pcs.) must touch the floor completely.
- Casters need not be touching the floor.

3. Attach the anti-seismic bracket to the adjustable foot, and tighten the nut (upper) of the adjustable foot to lock it.

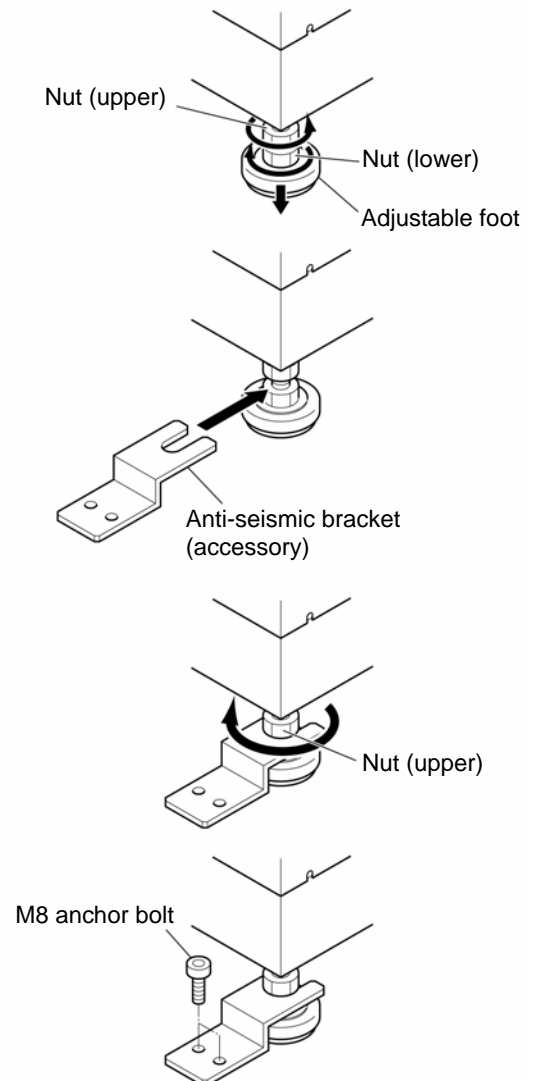



Figure 3-5 Anti-seismic Bracket Attachment

4. Secure the anti-seismic bracket with the anchor bolts. Repeat procedures for additional brackets.

3.3.4 Wiring installation

⚠ WARNING



- Only designated personnel are allowed to install wiring.
- Be sure to turn OFF the power prior to wiring to assure safety. Do not do any wiring when the system is energized.
- The system wiring requires not only a thorough connection with the designated cable but also securing to prevent loose connection. Poor connection and securing may cause electric shock, heat spots, fire or communication errors.
- Be sure to supply the power to this system according to specifications.
- Supply pure AC power. Potential malfunction may occur if a rectified AC with voltage rise (dv/dt) at zero crossing exceeds 40V /200μ sec.
- Always establish a connection to a ground for safety.
- Be sure that no ground connection is made to a water pipe, gas pipe and lighting rod.

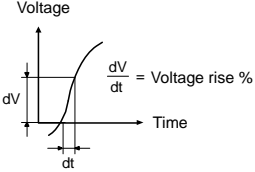

■ Power cable

The power cables are to be prepared under your responsibility, referring to the following table.

Table 3-1 Power Cable and Main Breaker (This System)

Item		HRZ001-H HRZ001-H1 HRZ002-H HRZ002-H1	HRZ001-L HRZ001-L1 HRZ001-L2 HRZ002-L HRZ002-L1 HRZ002-L2 HRZ004-L HRZ004-L1 HRZ004-L2 HRZ008-L2 HRZ004-H HRZ004-H1 HRZ008-H HRZ008-H1 HRZ002-W HRZ002-W1 HRZ008-W HRZ008-W1	HRZ008-L HRZ008-L1	HRZ010-WS HRZ010-W1S HRZ010-W2S	
Power cable	Size (recommended)	10AWG×4-conductor	10AWG×4-conductor	4AWG×4-conductor	10AWG×4-conductor	
	Crimp contact (recommended)	Breaker	R5.5-5	R5.5-5	R22-8	R5.5-8
		Earth bar	R5.5-8	R5.5-8	R22-8	R5.5-8
	Torque (recommended)	Breaker	2.5N•m (1.84 ft-lbf)	2.5N•m (1.84 ft-lbf)	6N•m (4.43 ft-lbf)	6N•m (4.43 ft-lbf)
Earth bar		12.5N•m (9.22 ft-lbf)	12.5N•m (9.22 ft-lbf)	12.5N•m (9.22 ft-lbf)	12.5N•m (9.22 ft-lbf)	
Main breaker (This System)		20A	30A	60A	30A	

■ Communication connector

The communication connectors are to be prepared under your responsibility, referring to the following table.

Table 3-2 Communication Connector

Connector	Type (for your system)
Contact signal (P1 connector)	D-Sub 25-pin (male)
Serial RS-485 (P2 connector)	D-Sub 9-pin (male)

■ Selection of the breaker for the customer's equipment (primary side)

⚠ CAUTION



This product is equipped with the breaker which has different operating characteristics depending on each model. For the customer's equipment (primary side), use the breaker whose operating time is equal to or longer than the breaker of this product. If the breaker with shorter operating time is connected, the customer's equipment could be cut off due to the inrush current of the motor of this product.

HRZ001-L	HRZ002-L	HRZ004-L	
HRZ001-L1	HRZ002-L1	HRZ004-L1	
HRZ001-L2	HRZ002-L2	HRZ004-L2	HRZ008-L2
HRZ001-H	HRZ002-H	HRZ004-H	HRZ008-H
HRZ001-H1	HRZ002-H1	HRZ004-H1	HRZ008-H1
HRZ002-W	HRZ008-W	HRZ002-W1	HRZ008-W1

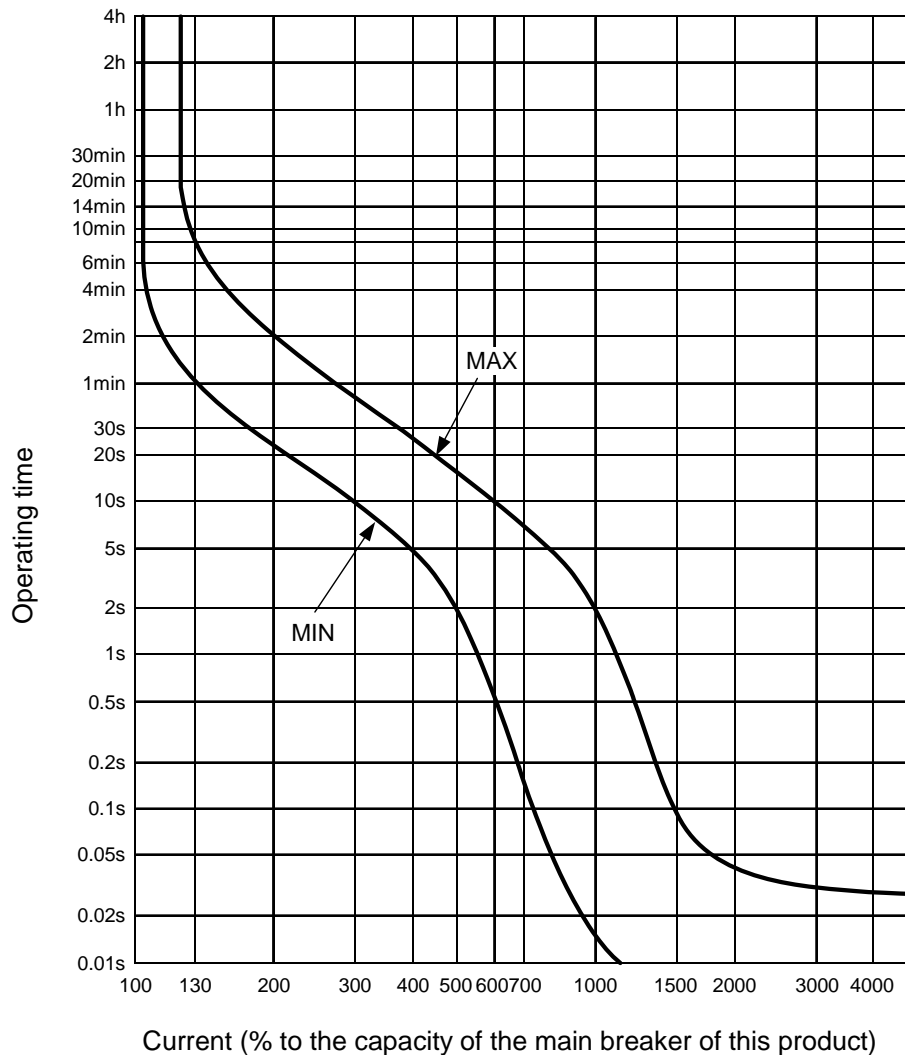

Figure 3-6 Breaker operating characteristics curve

HRZ008-L HRZ008-L1 HRZ010-WS HRZ010-W1S HRZ010-W2S

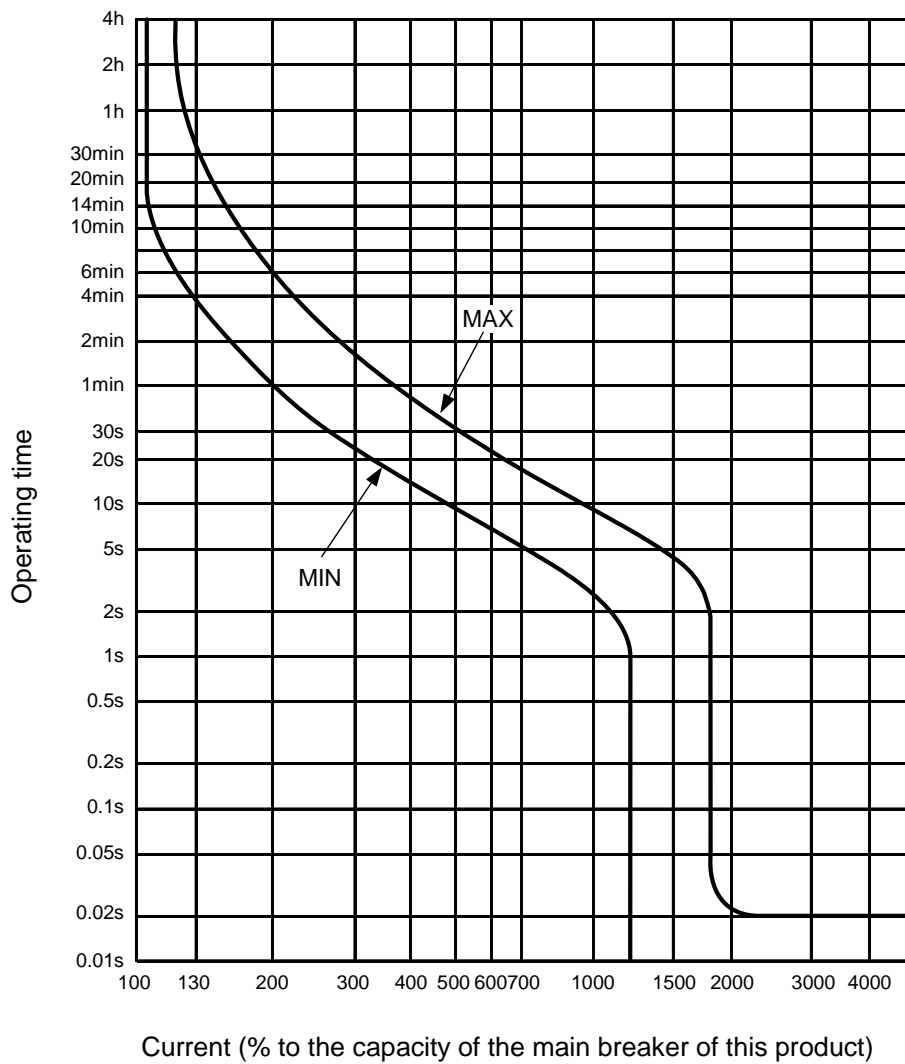

Figure 3-7 Breaker operating characteristics curve

3.3.5 Procedures for wiring installation

⚠ WARNING



Be sure to turn OFF the factory side (primary side) power before connection to this system.
Use the assigned procedure to perform lockout/tagout (Page 1-10).

1. Turn OFF the power breaker on customer side (primary side), and then use the assigned procedures to perform lockout/tagout.

[Tips]

Connection of the power cable with this system must be established first.
Do not connect the cable with the factory side at this point.

2. Turn OFF the main breaker of this system.

3. Undo the screws (2 pcs.) to remove the front panel.

Be sure to use a Phillips screwdriver.

4. Undo the screws (2 pcs.) to remove the breaker cover.

Be sure to use a Phillips screwdriver.

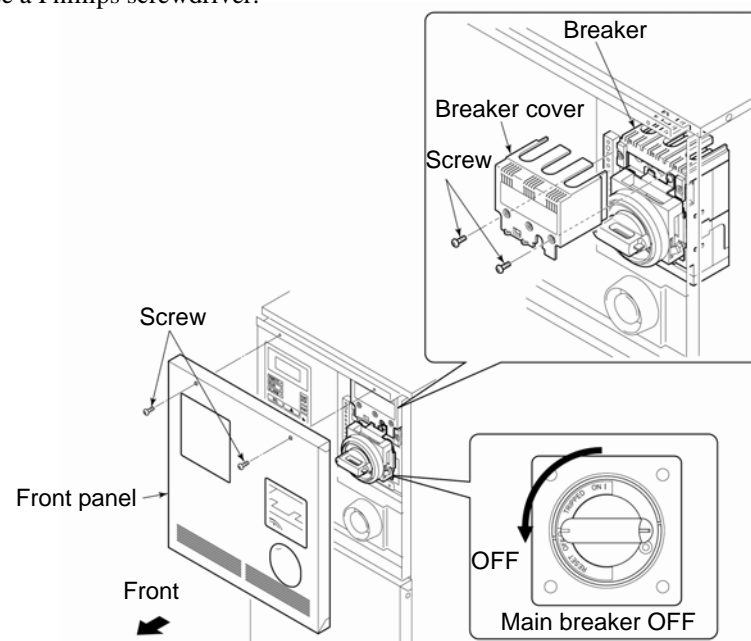

Figure 3-8 Main Breaker OFF and Removal of Front Panel/Breaker Cover

[Tips]

Make sure the breaker is at the 'OFF' position.
Otherwise, the removal of the front panel is not possible.

5. Loosen the cap and insert the power cable from the power cable access.

6. Connect the communication cables with P1 and P2.

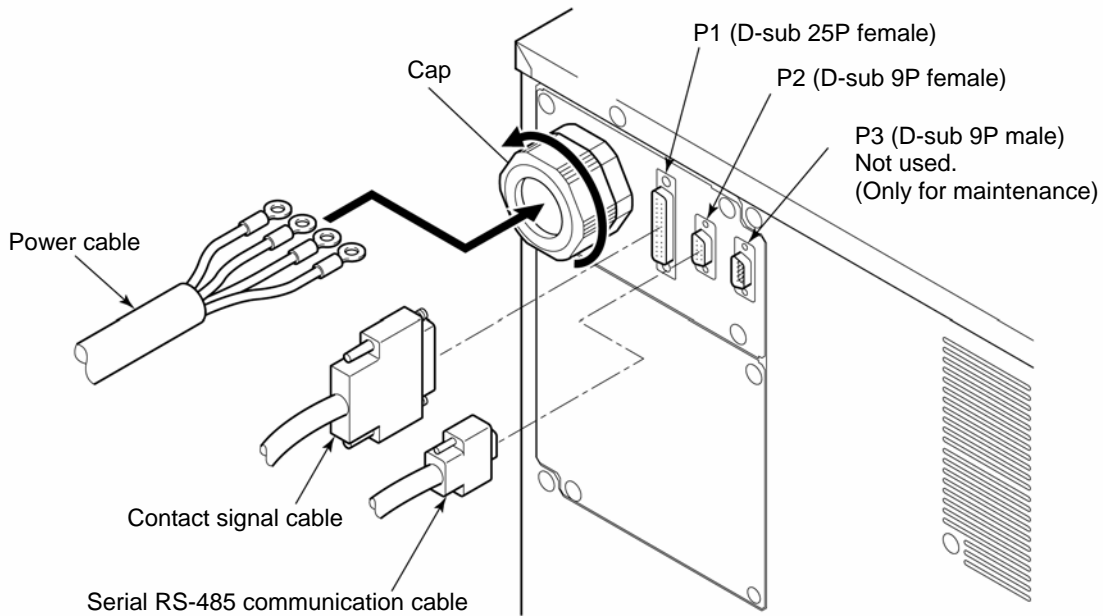

Figure 3-9 Power Cable Insertion and Communication Cable Connection

CAUTION



Correct phase rotation is required when attach the power cable to the breaker terminal.

CAUTION



**Do not drop a screw or washer in the electrical unit when attaching the breaker cover and terminal.
Do not leave it in the unit if dropped in. Potential failure may occur if the power is turned ON without removing it.**

[Tips]

See "Table 3-1 Power Cable and Main Breaker (This System)" on page 3-1 for the recommended cable size and crimp contact.

7. Connect the power cables to the breaker terminal.

Be sure to use a Phillips screwdriver. See Table 3-1 on Page 3-1 for recommended torque.

8. Connect the grounding terminal (M8) of the power cable to the earth bar.

Be sure to use a 13-mm open end wrench.

Recommended torque: 12.5 N•m (9.22 ft-lbf)

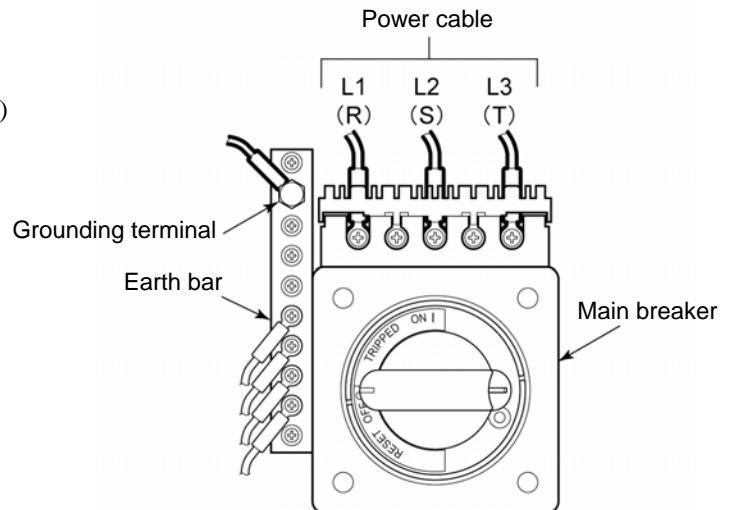

Figure 3-10 Connection of Power Cable and Grounding Terminal

[Tips]

See "Table 3-1 Power Cable and Main Breaker (This System)" on page 3-1 for torque value.

9. Attach the breaker cover to the breaker.**10.** Attach the front panel.**11.** Connect the power cable to the power breaker on customer side (primary side).

3.3.6 Installation of circulating fluid and facility water piping

⚠ CAUTION



- Choose proper external piping with consideration for pressure, temperature and compatibility with the circulating fluid. Potential pipe rupture during operation may occur if disregarded.
- Always insulate external circulating piping. Potential insufficient cooling performance due to heat absorption from the pipe surface and potential insufficient heating performance caused by thermal radiation if disregarded.
- Use clean pipes and pipe fittings, free of particles, oil and moisture. Apply air blow to the parts before using. The presence of particles, oil or moisture in the circulating fluid circuit causes insufficient cooling, system failure attributed to moisture freeze when entering the system, or foaming of the circulating fluid in the tank.
- The total capacity of circulating fluid required by external piping should remain under the capacity of the sub tank. Potential problem of tank overflow, when pump stop, may occur if disregarded. See “Appendix 8.1.1 System specification” in Chapter 8 for the capacity of the sub tank.
- Be sure to choose a circulating fluid pipe capable of letting the fluid flow at rated flow rate or better. See “Pump performance” defined in “Appendix 8.1.1 System specification” for the flow rate rating.
- Have a drip pan available incase of a fluid leak.
- Make sure of the locations of ports for the circulating fluid supply, return, facility water inlet, outlet and their corresponding connections are correct.
- Secure the piping connector section with a pipe wrench, and provide proper tightening to the pipe. See Figure 3-10 on page 3-13.
- Do not give an impact when the piping connector section is fixed or tightened. It may damage the piping or cause leakage.

■ Pipe diameter

Table 3-3 Pipe Diameter

Pipe	Diameter	Recommended torque (Material: SS* vs SS)
Facility water inlet	Rc1/2	28 to 30N•m (20.7 to 22.1ft-lbf)
Facility water outlet	Rc1/2	28 to 30N•m (20.7 to 22.1ft-lbf)
Circulating fluid supply	Rc3/4	28 to 30N•m (20.7 to 22.1ft-lbf)
Circulating fluid return	Rc3/4	28 to 30N•m (20.7 to 22.1ft-lbf)
Main tank drain port	Rc3/8 (with valve)	Piping not necessary
Sub tank drain port	Rc3/8 (with valve)	Piping not necessary
Drain pan port	Rc3/8	Piping not necessary

*: SS Stainless steel

■ **Procedure for piping installation**

Secure the pipe coupling section with a pipe wrench, and provide proper tightening to the pipe.

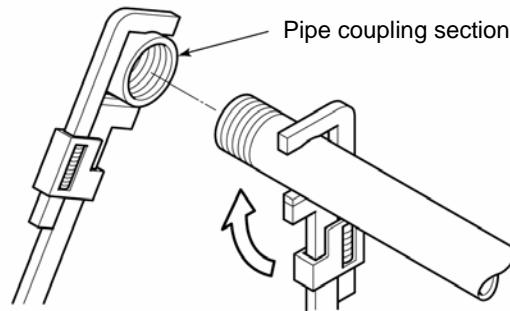

Figure 3-11 Pipe Tightening

■ **Recommended piping installation**

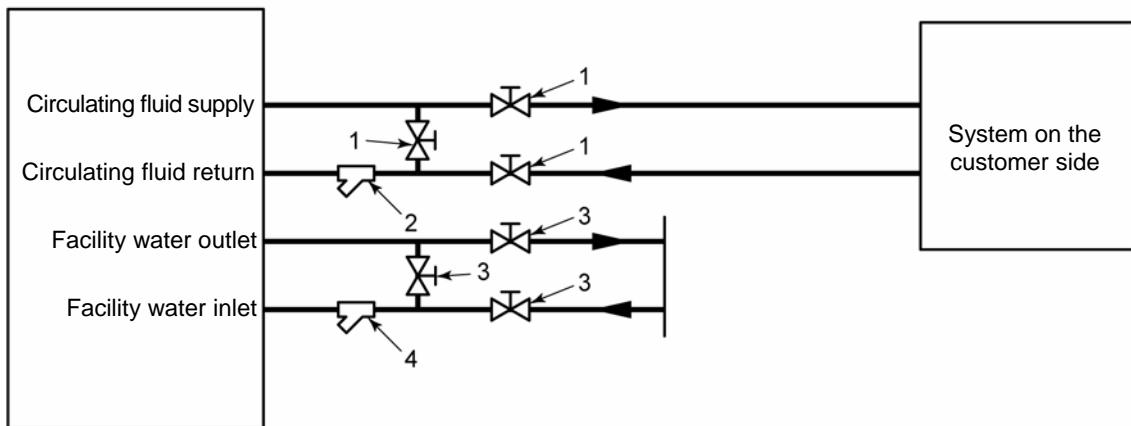

Figure 3-12 Recommended Piping Installation

Table 3-4 Recommended Pipe

No.	Name	Size	Material
1	Valve	Rc3/4	Stainless steel
2	Y-strainer (100μm)	Rc3/4	Stainless steel
3	Valve	Rc1/2	Stainless steel
4	Y-strainer (5μm)	Rc1/2	Stainless steel

Chapter 4 System Startup and Shutdown

⚠ CAUTION



Only personnel, who have adequate knowledge of and experiences with not only this system but associated equipment, are allowed to implement system startup and shutdown.

4.1 Pre-check

Check the following items prior to starting up the system.

4.1.1 Installation condition

- Make sure that the system is installed in a horizontal position.
- No heavy object is placed on this system. This system should not be applied with an undue force such as caused by piping installation.
- Re-check the items defined in “3.2 Installation” on page 3-1.

4.1.2 Cable connection

Make sure proper connection of the power cable, ground, and communication cables.

4.1.3 Installation of circulating fluid and facility water piping

Make sure that circulating fluid and facility water piping are installed properly.

4.1.4 Operating signal from your system

Make sure that no remote signal is being issued from your system. System startup takes effect upon power-ON if this system receives a remote signal and it is in remote mode.

4.1.5 Check emergency off [EMO] switch

Make sure of the location of the emergency off [EMO] switch before operating the system. See section 1.6.1 “Emergency off [EMO] switch” in Chapter 1 “Safety” for details.

4.2 Opening of Facility water Valve

CAUTION



Check that the facility water complies with not only the water quality standard defined in section 7.1 “Water Quality Management” on page 7-1 but the requirements provided in “8.1.1 System specification” in Chapter 8 Appendix on page 8-1.

Open the facility water valve for water supply.

[Tips]

This system is outfitted with a water regulating valve inside.
Facility water may not flow upon system startup which is normal.

4.3 Supply of Circulating Fluid

CAUTION

 Circulating fluids to use vary with system models. See section 8.1.1 “System specification” in Chapter 8 for the designated circulating fluid for a specific model.

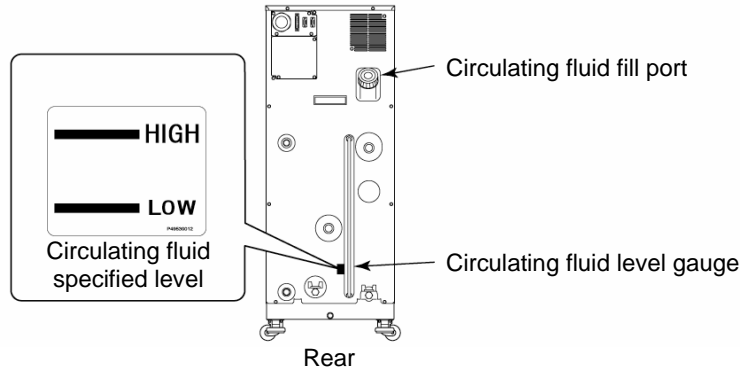

Figure 4-1 Circulating Fluid Fill Port and Circulating Fluid Level Gauge

4.3.1 Preparation of circulating fluid

■ When the circulating fluid is a 60% ethylene glycol aqueous solution

Always check the concentration of the circulating fluid.

CAUTION

- Low concentration EG in the circulating fluid may cause system failure due to it being frozen in the system.
- High concentration EG in the circulating fluid may cause circulating pump overload, which triggers “Pump Breaker Trip FLT”.
- Potential cooling error may occur if the circulating fluid varies in concentration.

■ When the circulating fluid is a fluorinated fluid

CAUTION

Make sure of no oil, moisture, and other foreign materials contaminate the circulating fluid. Potential cooling error or system failure, due to contaminant freezes internally, may occur if disregarded.

■ When the circulating fluid is water

CAUTION

Attention should be taken on water quality. Ensure water quality is within specified range, and other foreign materials contaminate the circulating fluid. Potential cooling error or system failure, due to contaminant freezes internally, may occur if disregarded.

4.3.2 Supply of circulating fluid

Remove the circulating fluid fill cap, and fill the circulating fluid until it reaches its specified level.

The circulating fluid specified level is a range between “HIGH” and “LOW” in Figure 4-1.

Be sure to tighten the cap until it clicks after fluid supply.

If the circulating fluid is supplied over the specified level, follow the procedure provided in section 7.3.1 “Draining of circulating fluid out of tank” on page 7-1 to drain excess fluid until it reaches the specified level.

[Tips]

Level between “HIGH” and “LOW” represent liquid level in normal running condition. Immediately as you start filling up the chiller, the internal transferring pump start pumping fluid from the Sub Tank into the Main Tank. Thus the fluid level in the level gauge will start to drop.

During initial priming of the external piping, addition fluid is needed. See section 8.1.1 “System specification” on page 8-1 for Sub Tank and Main Tank capacity.

WARNING



Circulating fluid must be supplied to be in the range between “HIGH” and “LOW”. Potential overflow of hot circulating fluid may occur due to excessive volume.

Total fluid volume use to fill up the system including initial priming should not exceed combined volume of Sub Tank and Main Tank. If level is below the “LOW” mark, this system will trigger an alarm.

CAUTION



When supplying the circulating fluid, make sure that the fluid inside this system has dropped to room temperature for the prevention of burns.

CAUTION



To prevent moisture, which is formed by condensation of a flowed air, from finding its way into the tank, ensure the circulating fluid at room temperature when supplying the fluid.

Be sure to tighten the cap until it clicks after fluid supply. Potential circulating fluid vaporization or moisture intrusion due to condensation of flowed air may occur if disregarded.

4.4 Requirement for System Startup

4.4.1 Turning ON power

1. Make sure that the main breaker for this system is OFF, and release lockout/tagout of the power breaker on customer side (primary side). Then, turn ON the power.
-
2. Turn ON the main breaker of this system.

The “Model Indication screen” and “System Information screen” are displayed in sequence on the LCD screen. The screen will change to the “Status screen 1” in approx. 20 seconds, and the system is ready to run.

[Tips]

It is normal if the “System Information screen” is not displayed. See section 5.3.13 “System Information screen” in “Chapter 5 System Operation” on page 5-1 for details.

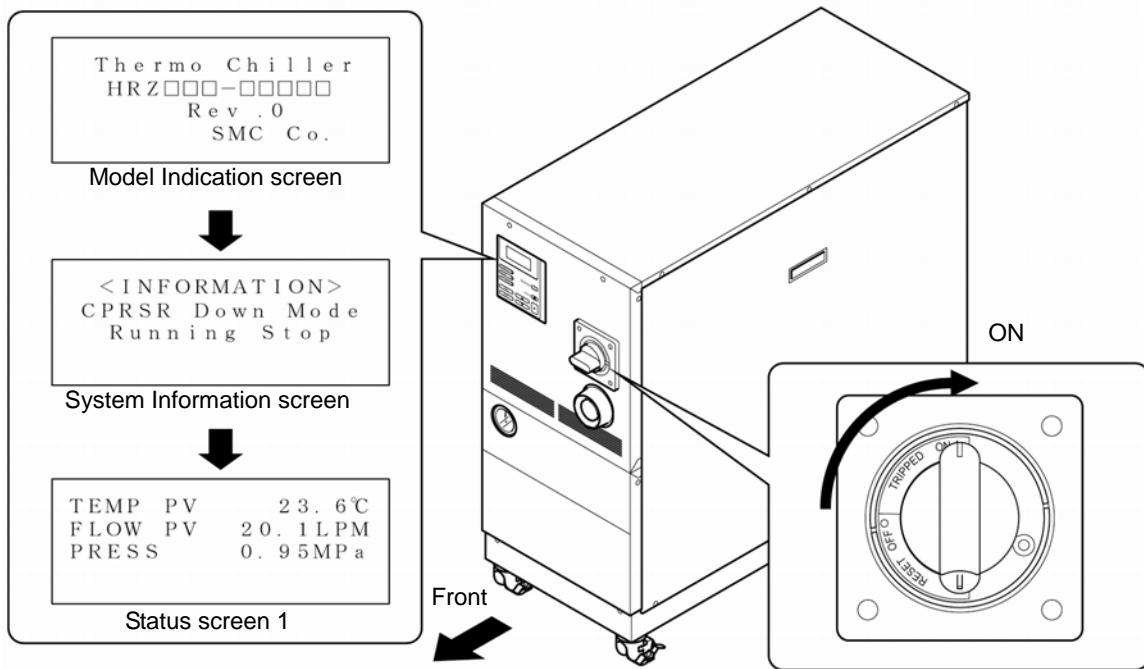

Figure 4-2 Main Breaker at 'ON'

⚠ WARNING

Press the emergency off [EMO] switch immediately upon occurrence of abnormal conditions. Be sure to turn OFF the main breaker afterwards.

4.4.2 Circulating fluid temperature setting

From the “Setting screen” on the LCD screen, set the circulating fluid at any temperature. See section 5.4 “Examples of System Operation” in “Chapter 5 System Operation” on page 5-1 for operating procedure.

[Tips]

See section 8.1.1 “System specification” in “Chapter 8 Appendix” on page 8-1 for the setting range of circulating fluid temperature.

4.5 System Startup and Shutdown

4.5.1 System startup

Press the [START/STOP] key on the operation display panel.

The [RUN] lamp on the operation display panel comes on, and the “System Information screen” is flashing. The screen then change to the “Status screen 1”, which initiates system operation.

[Tips]

It is normal if the “System Information screen” is not displayed. See section “5.3.13 “System Information screen” in “Chapter 5 System Operation” on page 5-1 for details.

4.5.2 System shutdown

Press the [START/STOP] key on the operation display panel.

The “System Information screen” is flashing on the LCD screen, and the [RUN] lamp comes on. The compressor comes to a halt approx. 30 seconds after circulating pump stop for protection of the compressor. The screen is returned to the “Status screen 1”, which prompts the [RUN] lamp to go out.

[Tips]

See section 5.3.13 “System Information screen” in “Chapter 5 System Operation” on page 5-1 for details on the System Information screen.

CAUTION



Internal equipment may remain at elevated or lowered in temperature immediately after system shutdown. Potential burns or frostbite may happen if your skin comes in contact with these surfaces. Further work is allowed only when the system reaches room temperature.

CAUTION



Emergency off [EMO] switch and main breaker (OFF) should not be used for system shutdown unless it is an emergency.

Chapter 5 System Operation

5.1 Operation Display Panel

Use the operation display panel located in front of the system for the basic operations.

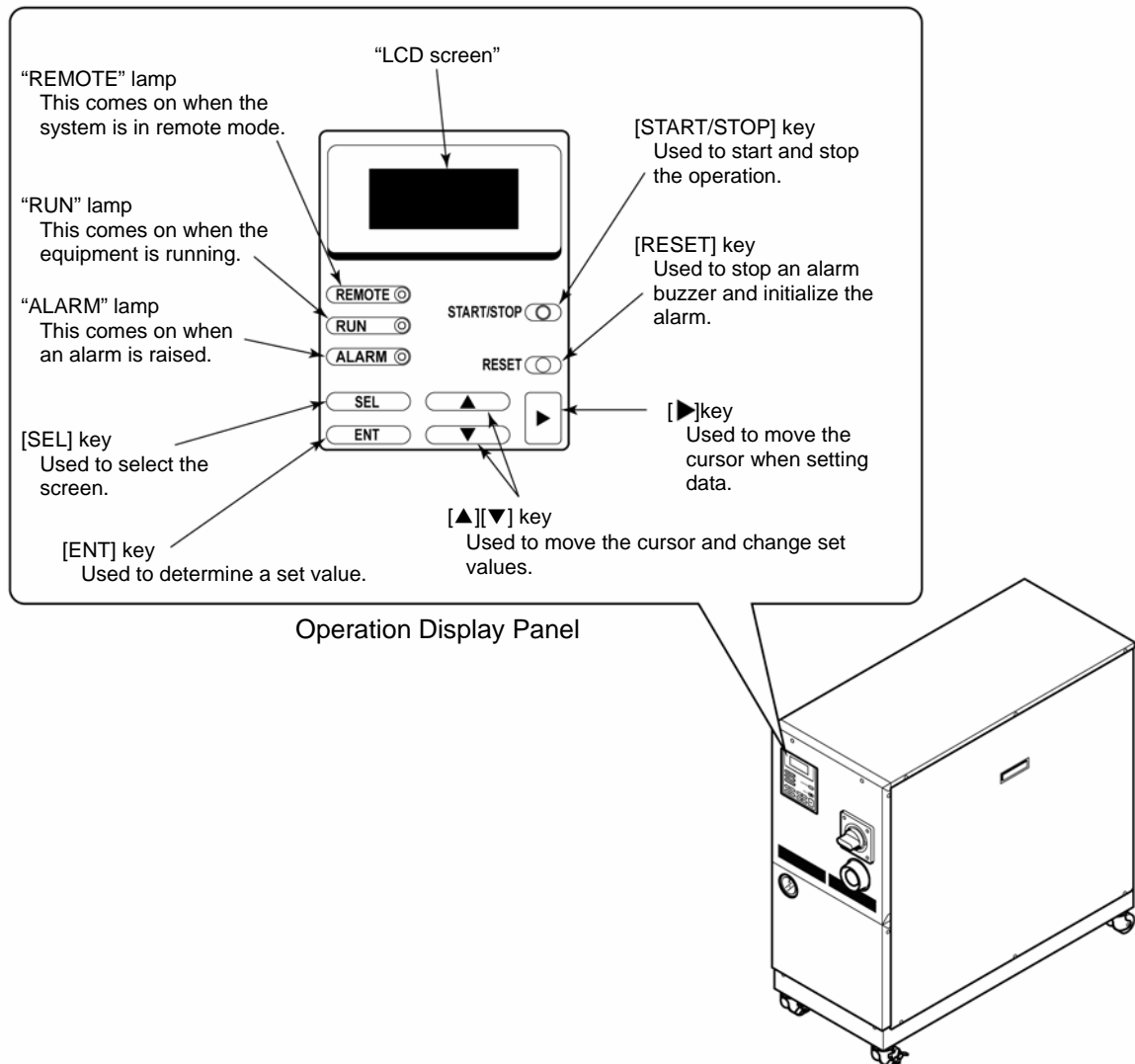

Figure 5-1 Operation Display Panel

CAUTION

Be sure to use your fingers only to operate the Operation Display Panel. Using sharp object will damage the panel.

5.2 Flow Chart of Operation Screen

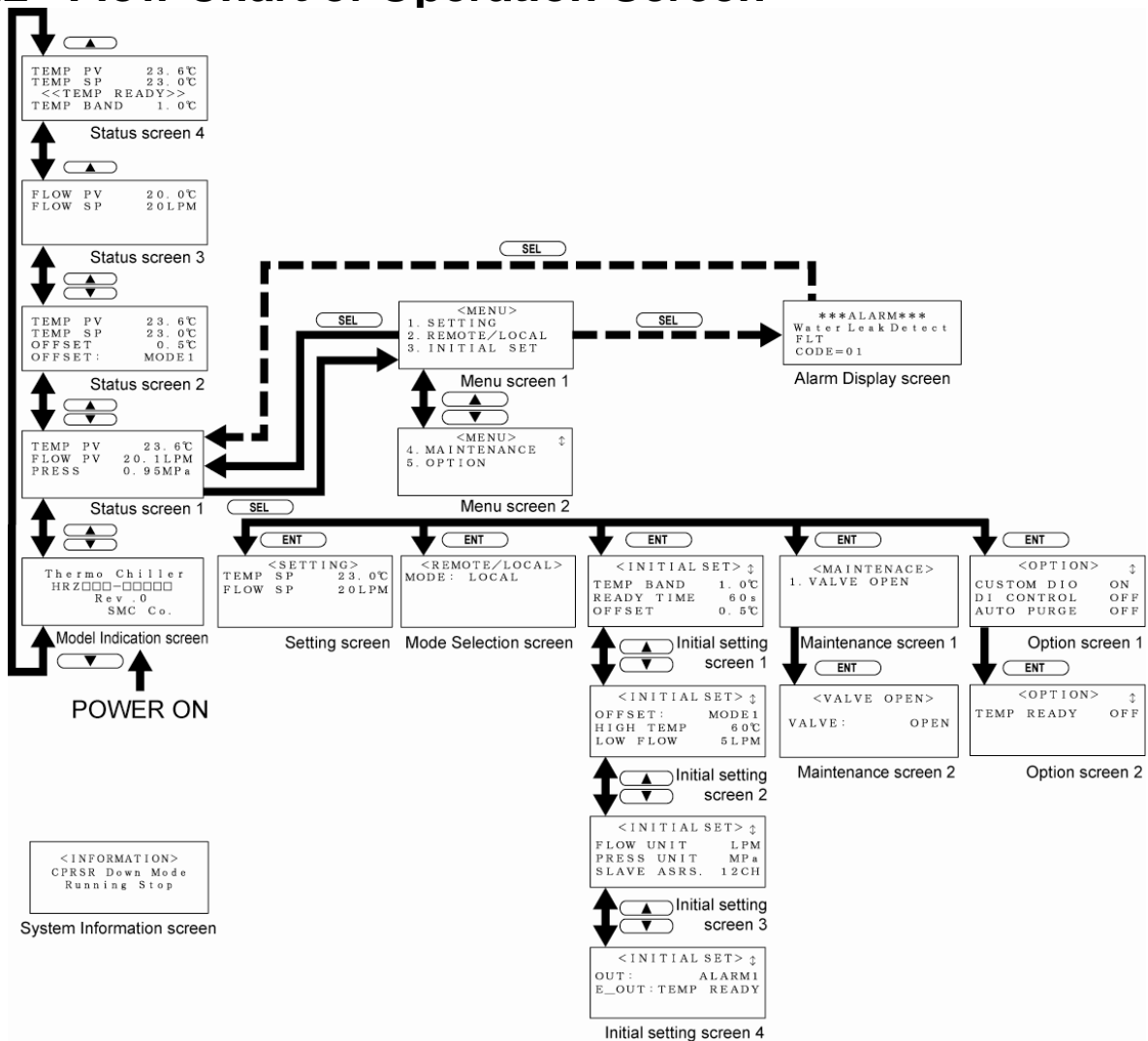

Figure 5-2 Flow Chart of Operation Screen

[Tips]

With the press of the [SEL] key, the screen is switched to the “Menu screen 1” regardless of the screen status.

Table 5-1 Descriptions of Operation Screens

Screen	Descriptions	Reference
Model Indication screen	Displays the model and revision No. of this system.	Page 5-1
Status screen 1, 2, 3, 4	Displays the operating condition of this system.	Page 5-1, 5-1, 5-1
Menu screen 1, 2	Allows setting screen selection.	Page 5-1
Setting screen	Allows the setting of TEMP SP value.	Page 5-1
Mode Selection screen	Allows communication mode selection.	Page 5-1
Initial Setting screen 1, 2, 3, 4	Allows the setting of set values.	Page 5-1
Maintenance screen 1, 2	Not used during system operation. Not allowed to use unless otherwise specified.	Page 5-1
Option screen 1, 2	Allows the setting of option.	Page 5-1
Alarm Display screen	The alarm message is displayed in the event of an error in this system. Not displayed if no error.	Page 5-1
System Information screen	Displays the status of system startup and shutdown.	Page 5-1

5.3 Operation Screen

5.3.1 Model Indication screen

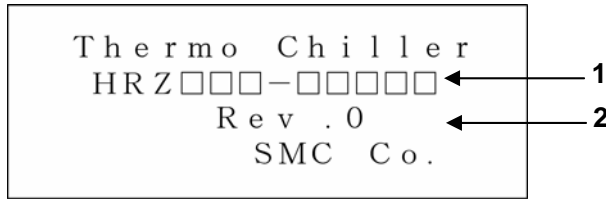
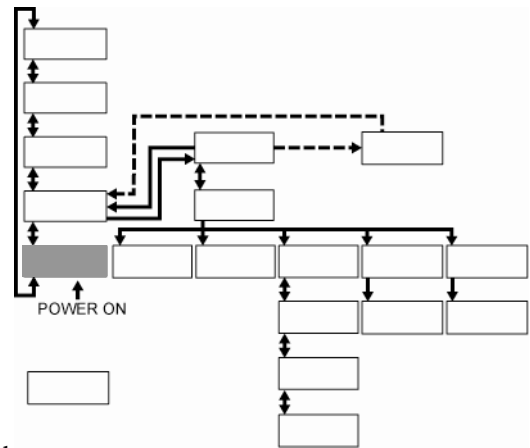

Figure 5-3 Model Indication Screen



The “Model Indication screen” is displayed upon power-ON of this system. This screen remains ON for approx. 20 seconds and is automatically switched to the “Status screen 1”. The “Alarm Display screen” is displayed if error occurs in this system.

Table 5-2 Model Indication Screen

No.	Item	Descriptions
1	-	System model
2	-	System revision No.

5.3.2 Status screen 1

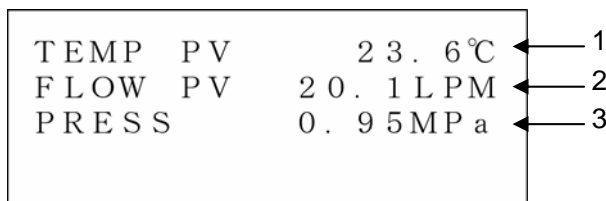

Figure 5-4 Status Screen 1

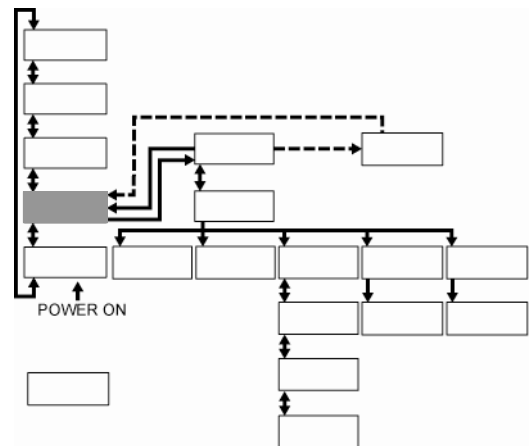

Table 5-3 Status Screen 1

No.	Item	Descriptions
1	TEMP PV	Discharge temperature of the circulating fluid (A value derived according to the offset ^{*1} if applied)
2	FLOW PV ^{*2}	Return flow rate of the circulating fluid
3	PRESS	Discharge pressure of the circulating fluid

[Tips]

See “Appendix 8.4 Offset Function” in Chapter 8 on page 8-1 for details on offset (*1).

When using accessory [by-pass piping set] flow becomes total of flow on customer side and flow on by-pass (*2).

5.3.3 Status screen 2

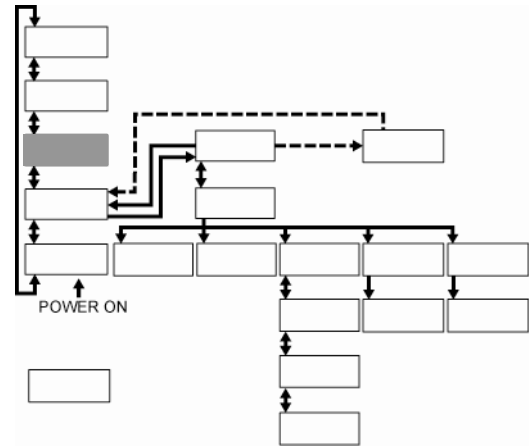
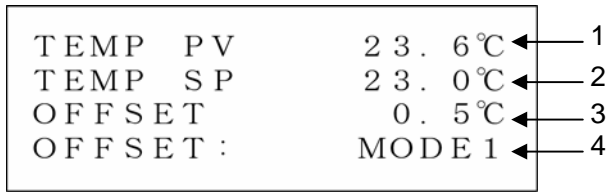

Figure 5-5 Status Screen 2

Table 5-4 Status Screen 2

No.	Item	Descriptions
1	TEMP PV	Discharge temperature of the circulating fluid (A value derived according to the offset ^{*1} if applied)
2	TEMP SP	Set circulating fluid temperature
3	OFFSET	Set offset ^{*1}
4	OFFSET	The current offset mode

[Tips]

See “Appendix 8.4 Offset Function” in Chapter 8 on page 8-1 on offset features (*1).

5.3.4 Status screen 3

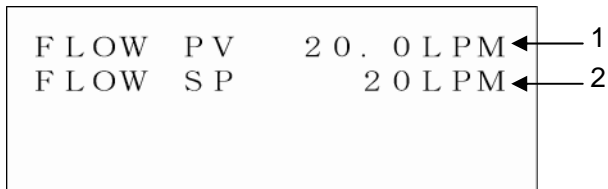

*Status screen 3 is only indicated on HRZ010-W*S.

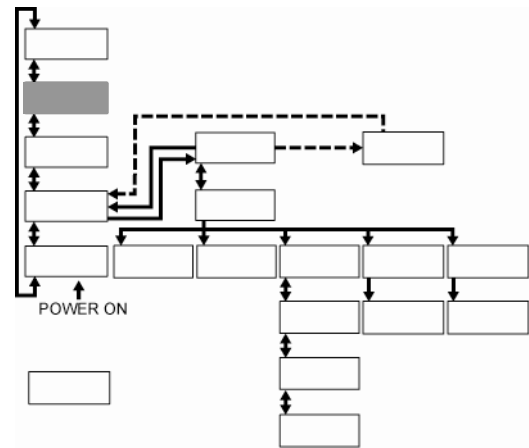

Figure 5-6 Status Screen 3

Table 5-5 Status Screen 3

No.	Item	Descriptions
1	FLOW PV ^{*1}	Return flow rate of the circulating fluid
2	FLOW SP ^{*1}	Set Return flow rate

[Tips]

When using accessory [by-pass piping set] flow becomes total of flow on customer side and flow on by-pass (*1).

5.3.5 Status screen 4

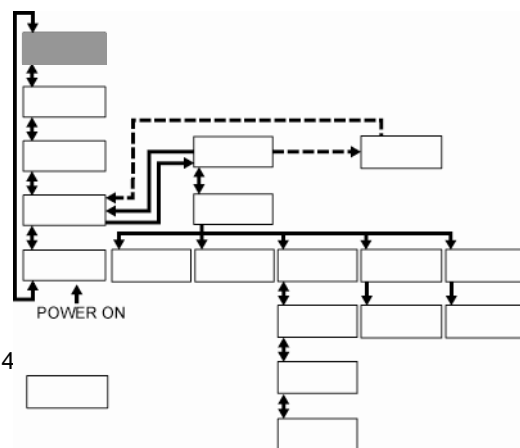
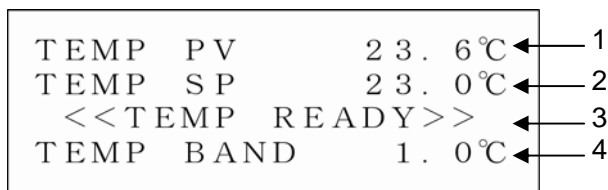

Figure 5-7 Status Screen 4

Table 5-6 Status Screen 4

No.	Item	Descriptions
1	TEMP PV	Discharge temperature of the circulating fluid
2	TEMP SP	Set circulating fluid temperature
3	<<TEMP READY>>	Displays the BAND/READY [Displayed when set value conditions are satisfied] *1
4	TEMP BAND	Set value of BAND range *1

[Tips]

See “Appendix 8.5 BAND/READ” in Chapter 8 on page 8-1 on offset features (*1).

5.3.6 Menu screen

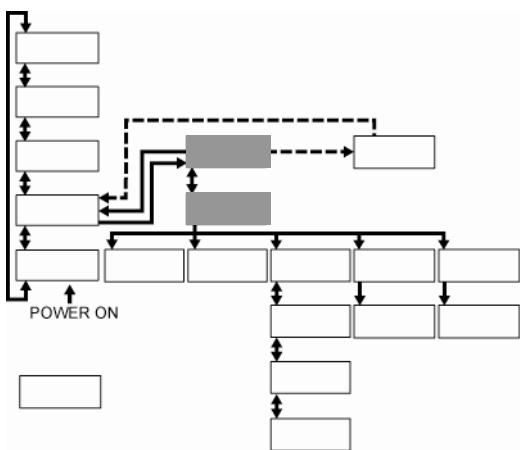
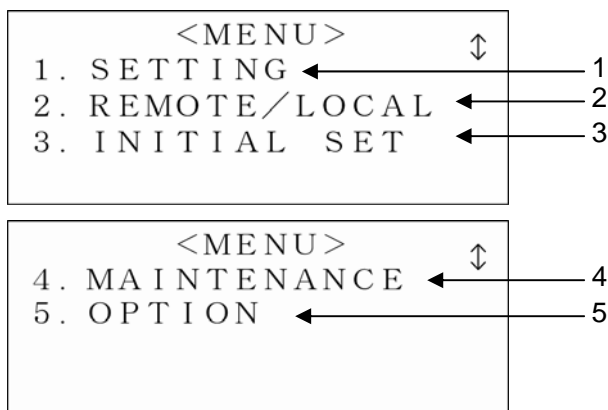

Figure 5-8 Menu Screen

Table 5-7 Menu Screen

No.	Item	Descriptions
1	SETTING	Switches to the “Setting screen” with the press of the [ENT] key.
2	REMOTE/LOCAL	Switches to the “Mode Selection screen” with the press of the [ENT] key.
3	INITIAL SET	Switches to the “Initial Setting screen 1” with the press of the [ENT] key.
4	MAINTENANCE	Switches to the “Maintenance screen 1” with the press of the [ENT] key.
5	OPTION	Switches to the “Option screen” with the press of the [ENT] key.

5.3.7 Setting screen

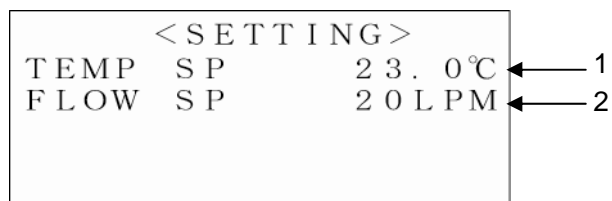
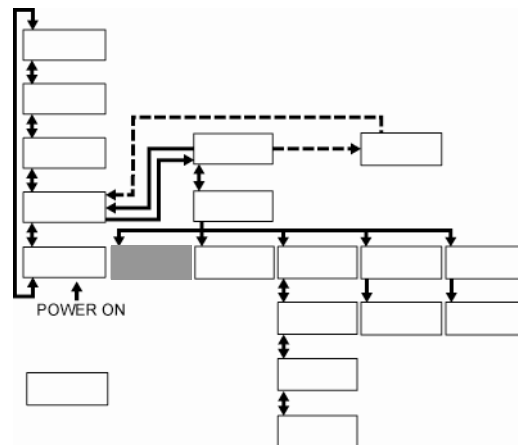

Figure 5-9 Setting Screen



This screen enables the setting of TEMP SP value.
 Not available if the communication mode is in "SER REMOTE"*1.

Table 5-8 Setting Screen

No.	Item	Setting range
1	TEMP SP	HRZ□□□-L□ : -20.0 to 40.0°C HRZ□□□-L2 : 10.0 to 40.0°C HRZ□□□-H□ : 20.0 to 90.0°C HRZ□□□-W□ : -20.0 to 90.0°C
2	FLOW SP	10 to 40LPM(2.6 to 10.6GPM) FLOW SP is only indicated on HRZ010-W*S and Setting is available.

[Tips]

See "5.3.8 Mode Selection screen" for details on "SER REMOTE" (*1).

5.3.8 Mode Selection screen

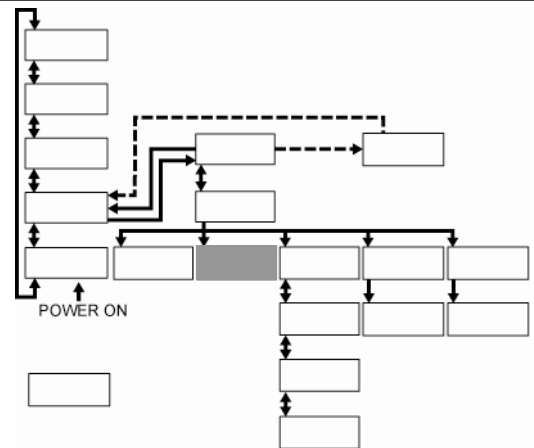
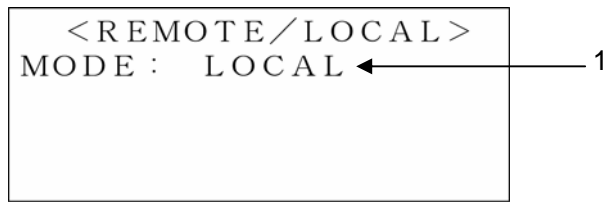

Figure 5-10 Mode Selection Screen

This screen enables the selection of the communication mode. The procedures for system start/stop and TEMP SP value setting may vary with the communication mode. Other operations and settings are available only from the operation display panel.

Table 5-9 Mode Selection Screen

No.	Item	Setting	
1	MODE	LOCAL	System start/stop and TEMP SP value setting are available only from the operation display panel.
		DIO REMOTE	System start/stop is allowed only through contact signal. TEMP SP value setting is available only from the operation display panel.
		SER REMOTE	System start/stop and TEMP SP value setting are available only through serial RS-485 communication.

5.3.9 Initial Setting screen

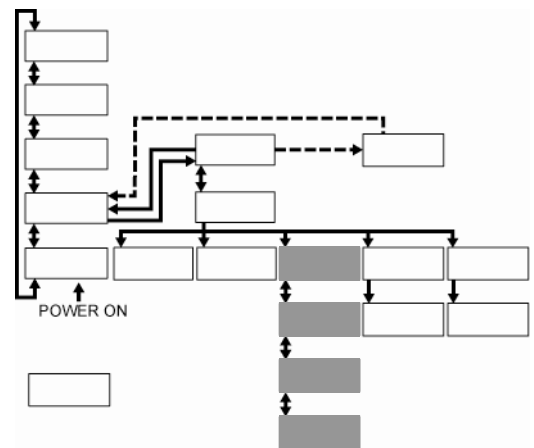
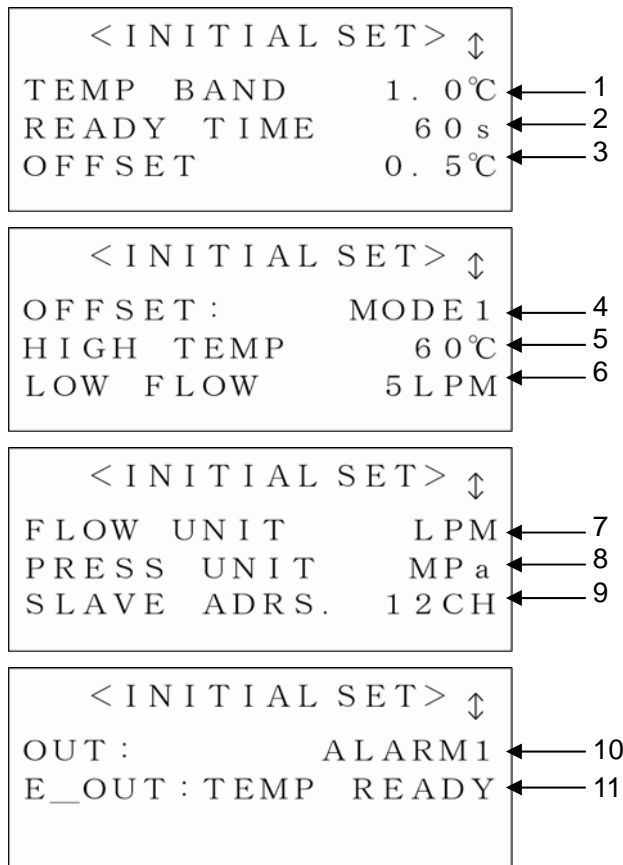

Figure 5-11 Initial Setting Screen

This screen enables the setting of set values.

Table 5-10 Initial Setting Screen

No.	Item	Setting range	Descriptions
1	TEMP BAND	1.0 to 5.0°C *1	Allows the selection of the band width for TEMP SP.
2	TEMP READY	10 to 480sec *1	Allows the setting of the time from TEMP PV value reaching BAND range to TEMP READY is displayed and put out.
3	OFFSET	-20.0 to 20.0°C *2	Calibrates variations in temperature between this system and your system. (See "Appendix 8.4 Offset Function" in Chapter 8 for details.)
4	OFFSET	OFF, MODE1, MODE2, MODE3	
5	HIGH TEMP	HRZ□□□-L□: -20 to 45°C HRZ□□□-L2: 10 to 45°C HRZ□□□-H□: 20 to 93°C HRZ□□□-W□: -20 to 93°C	Issues an alarm of "Reservoir High Temp WRN" if the circulating fluid exceeds the set temperature.
6	LOW FLOW	0, 15 to 40 LPM 0, 4 to 10.6 GPM	Issues an alarm of "Return Low Flow WRN" if the circulating fluid does not reach the set flow rate. Lift this alarm if the selection is "0". Even if the values from 1 to 14LPM (0.3 to 3.7GPM) are input, the setting value make 15LPM (4.0GPM). Even if the values from 1 to 7LPM (0.3 to 1.8GPM) are input, the setting value make 8LPM (2.1GPM). (Only for HRZ010-W*S)
		0, 8 to 40 LPM 0, 2.1 to 10.6 GPM (Only for HRZ010-W*S)	
7	FLOW UNIT	LPM, GPM	Allows the selection of the unit of flow rate.
8	PRESS UNIT	MPa, PSI	Allows the selection of the unit of pressure.
9	SLAVE ADRS.	1 to 16CH	Allows the selection of the slave address for serial RS-485 communication.
10	OUT	N/A ALARM1 to 25	Allows the selection of alarm signals for contact signal. (See Appendix 8.1.3 Alarm signal selection" for details.)
11	E_OUT	TEMP READY, AUTO PURGE*1	Allows the selection of EVENTOutput. (See Appendix 8.1.2 Communication specification" for details.)

[Tips]

Valid during option setting with "5.3.11 Option screen" on page 5-1.
See "Appendix 8.5 BAND/READ" in Chapter 8 on page 8-1 on BAND/READY function (*1).
TEMP SP+OFFSET value (*2) should be in the TEMP SP setting range defined in "Table 5-8 Setting Screen" on page 5-1.

5.3.10 Maintenance screen

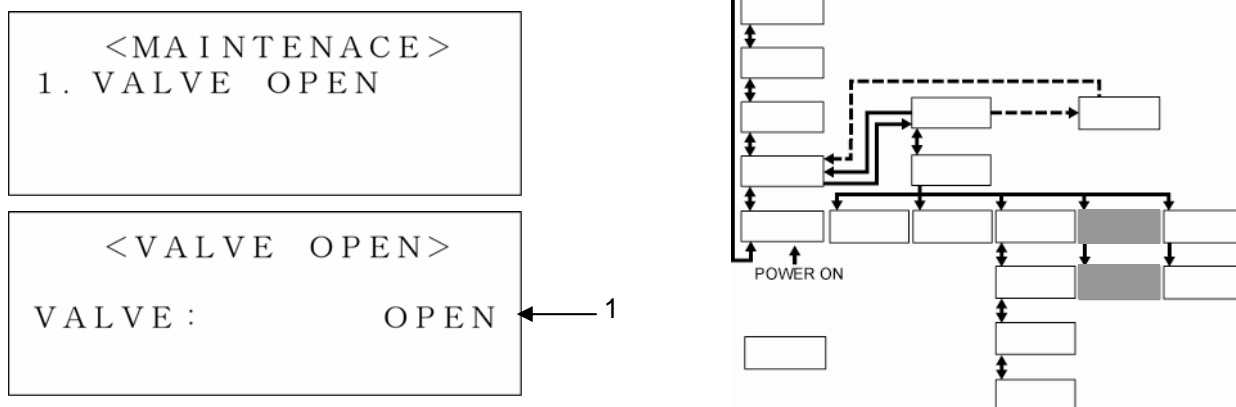

Figure 5-12 Maintenance Screen

Table 5-11 Maintenance Screen

No.	Item	Setting	
1	VALVE	OPEN	The solenoid valve is opened forcefully.
		CLOSE	The solenoid valve is closed forcefully.

[Tips]

Available only if a solenoid valve (optional for DI control kit) is provided.

5.3.11 Option screen

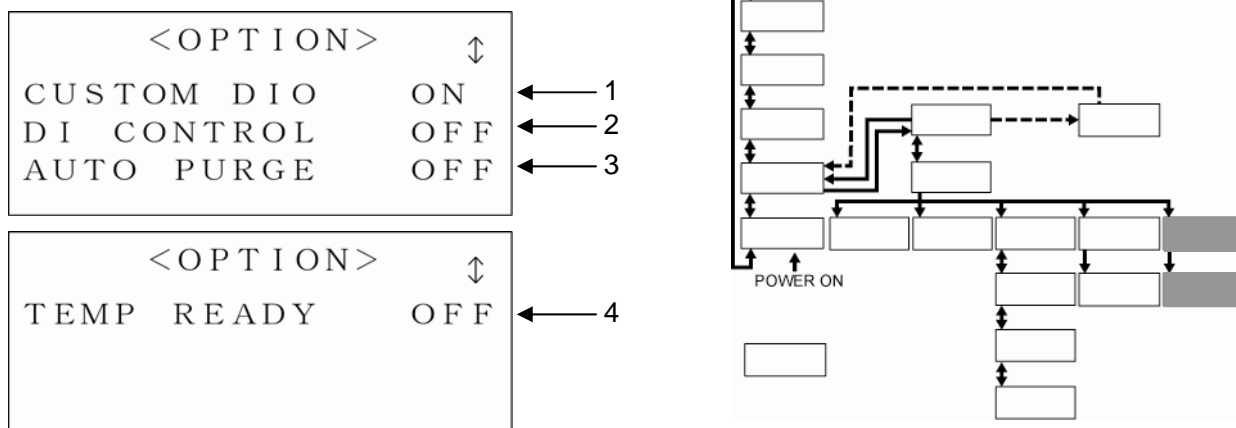

Figure 5-13 Option Screen

Table 5-12 Option Screen

No.	Item	Setting	Setting
1	CUSTOM DIO	ON / OFF	Allows the selection of Valid / invalid. (See "Communication specifications" for details.)
2	DI CONTROL	ON / OFF	"ON" is selected when shipped out of the factory for customer who purchased recirculating fluid electric resistance control function(optional). Do not change the set value.
3	AUTO PURGE	ON / OFF	"ON" is selected when shipped out of the factory for the customer who purchased recirculating fluid automatic collection function(optional). Do not change the set value.
4	TEMP READY	ON / OFF	Allows the selection of valid / invalid of BAND / READY function. This becomes valid after turning off the power, then supply the power again.

5.3.12 Alarm Display screen

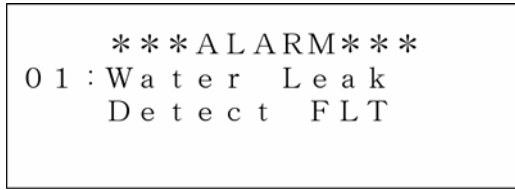
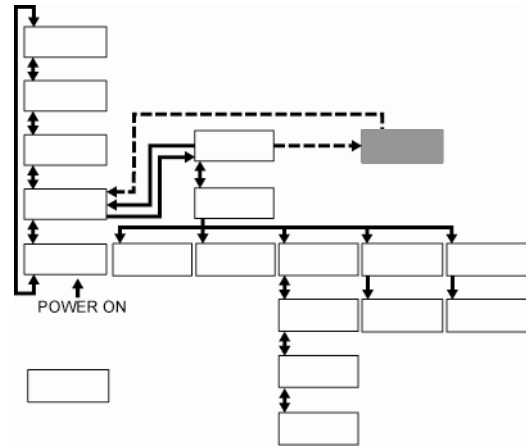

Figure 5-14 Alarm Display Screen



In the event of an error in this system, the current screen is switched to the Alarm Display screen to display the relevant alarm code, and message.

The Alarm Display screen is displayed only if an error is raised.

See section 6.2 “Troubleshooting” in “Chapter 6 Error Message and Troubleshooting” for alarm numbers and messages.

5.3.13 System Information screen

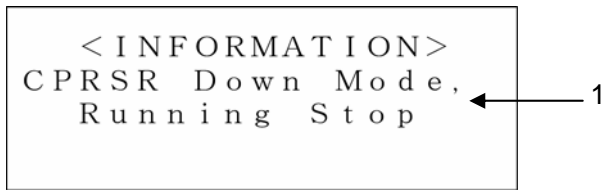
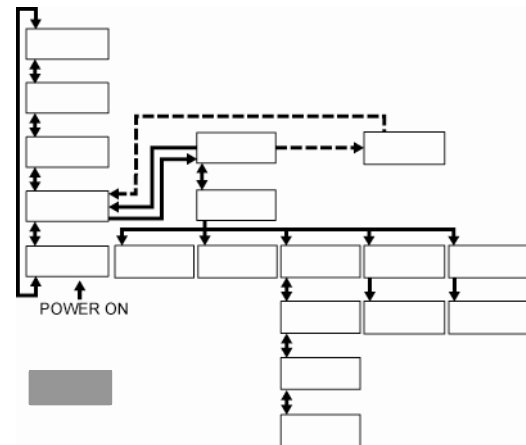

Figure 5-15 System Information Screen



The System Information screen, as shown above, may be displayed upon system start/stop.

Table 5-13 System Information Screen

No.	Message	Descriptions
1	Initialize Mode (RESERVOIR)	The circulating fluid flows in this system through the internal pump when turning ON the system. System operation is disabled if this message is displayed.
	Initialize Mode (CONTROL VALVE)	Positioning of the electronic expansion valve is performed when turning ON the system. System operation is disabled if this message is displayed.
	Pump Up Mode, Running Start	If your piping is supplied with an insufficient amount of the circulating fluid at system startup, the circulating pump in this system is activated (repeating ON/OFF) to replenish piping with the circulating fluid. Continuous operation is initiated once piping is replenished with the fluid.
	CPRSR Down Mode, Running Stop	Compressor operation remains for approx. 30 seconds after circulating pump stop for the protection of the compressor at the time of system shutdown.
	Stopping Internal Pump	The internal pump is at halt for a given length of time for protection of the pump. This message turns off after a lapse of the specified time.

5.4 Examples of System Operation

5.4.1 Example 1: Circulating fluid set temperature is changed from 23.0°C to 34.1°C.

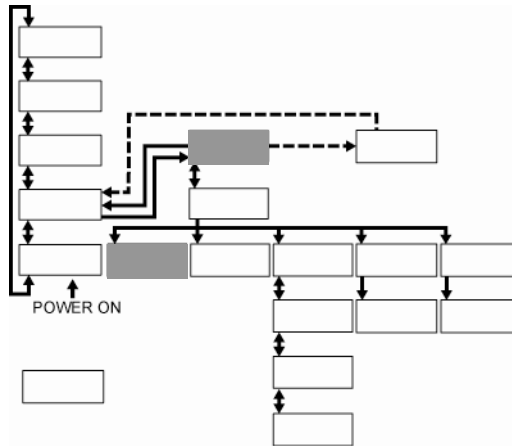

Figure 5-16 Change of Set Temperature from 25.0°C to 34.1°C

1. Press the [SEL] key to display the “Menu screen 1”.

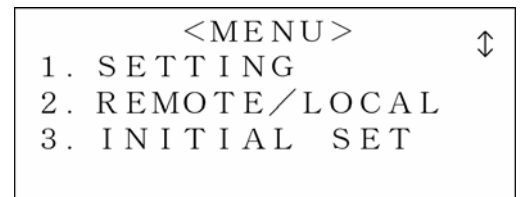

Figure 5-17 Menu Screen 1

2. With the use of the arrow keys ([▲], [▼]), move the cursor to “1. SETTING” and press the [ENT] key.

The “Setting screen” is displayed.



Figure 5-18 Setting Screen

3. Press the [ENT] key.

The cursor is now appear on the current value for TEMP SP, which enables change of the temperature set value.

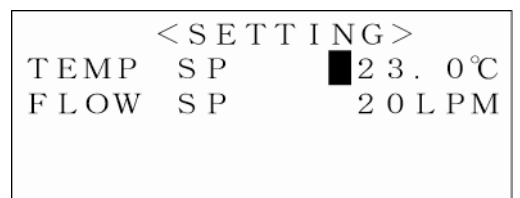

Figure 5-19 Setting Screen: Cursor Display

4. Use the arrow keys ([▲], [▼], [▶]) to change the temperature to 34.1°C.

[▲] key: Used to add one value on which the cursor is placed.

[▼] key: Used to subtract one value on which the cursor is placed.

[▶] key: Used to move the cursor to the right.

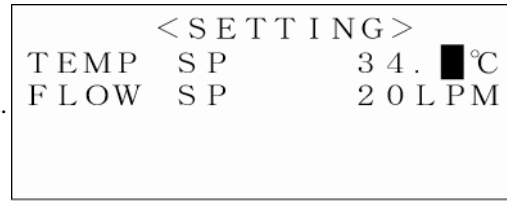

Figure 5-20 Setting Screen: Change of Set Value

[Tips]

To cancel a selection, press the [SEL] key, not [ENT] key. With the press of the [SEL] key, the cancellation takes effect and the screen is switched to the "Menu screen 1".

5. Press the [ENT] key with a new set temperature (34.1°C) entered.

The cursor goes out, and the setting takes effect.

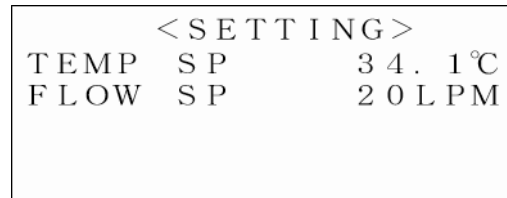

Figure 5-21 Setting Screen: Setting Confirmation

6. Press the [SEL] key to display the "Menu screen 1".

[Tips]

FLOW SP is only indicated on HRZ010-W*S and setting is available.

5.4.2 Example 2: Communication mode is switched from “DIO REMOTE” to “LOCAL”.

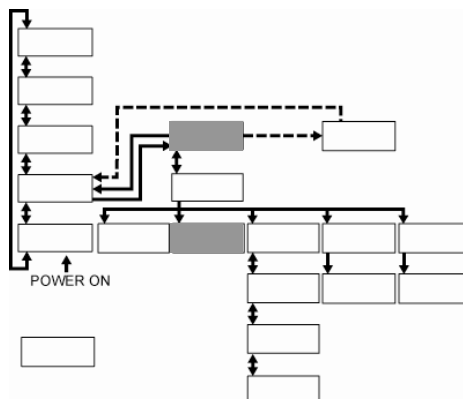

Figure 5-22 Switching of Communication Mode from “DIO REMOTE” to “LOCAL”

1. Press the [SEL] key to display the “Menu screen 1”.



Figure 5-23 Menu Screen 1

2. With the use of the arrow keys ([▲], [▼]), move the cursor to “2. REMOTE/LOCAL” and press the [ENT] key.

The “Mode Selection screen” is displayed.

- The name of the current mode flashes.



Figure 5-24 Mode Selection Screen: DIO REMOTE

3. Use the arrow keys ([▲], [▼]) to select “LOCAL”.



Figure 5-25 Mode Selection Screen: LOCAL

4. Press the [ENT] key.

The mode name stop flashing, and the selection takes effect.



Figure 5-26 Mode Selection Screen: Setting Confirmation

[Tips]

To cancel a selection, press the [SEL] key, not [ENT] key. With the press of the [SEL] key, the cancellation takes effect and the screen is switched to the “Menu screen 1”.

5. Press the [SEL] key to display the “Menu screen 1”.

5.4.3 Example 3: Alarm signal of contact signal is changed from “N/A” to “ALARM1”.

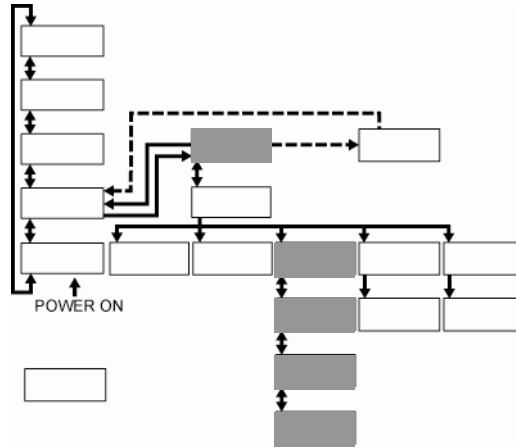

Figure 5-27 Change of Alarm Signal of Contact signal from “N/A” to “ALARM1”

1. Press the [SEL] key to display the “Menu screen 1”.

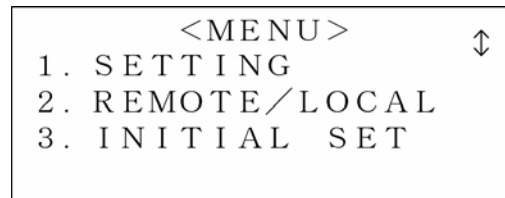

Figure 5-28 Menu Screen 1

2. With the use of the arrow keys ([▲], [▼]), move the cursor to “3. INITIAL SET” and press the [ENT] key.

The “Initial Setting screen 1” is displayed.

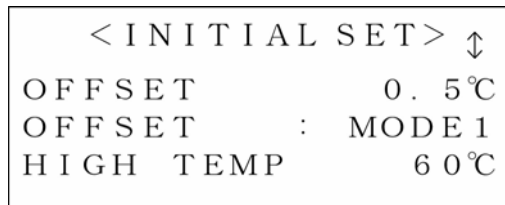

Figure 5-29 Initial Setting Screen 1

3. Use the arrow keys ([▲], [▼]) to display the “Initial Setting screen 3”, which prompts “OUT” to flash.

● The name of the current mode flashes.



Figure 5-30 Initial Setting Screen 3: OUT

4. Press the [ENT] key.

Only the current mode flashes.

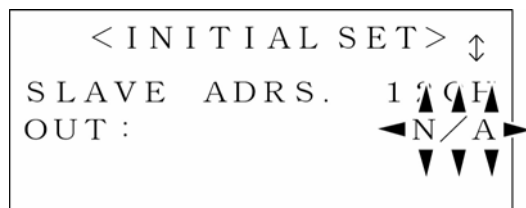

Figure 5-31 Initial Setting Screen 3: N/A

5. Use the arrow keys ([▲], [▼]) to select "ALARM1".

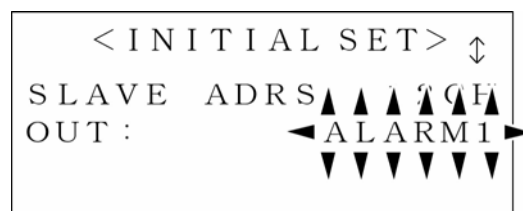

Figure 5-32 Initial Setting Screen 3: ALARM1

6. Press the [ENT] key.
"OUT" flashes again, and the selection takes effect.

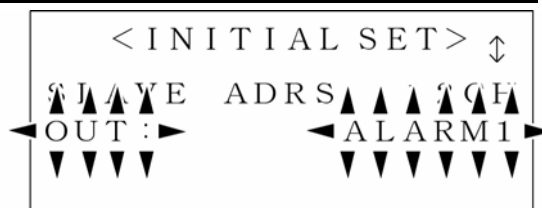

Figure 5-33 Initial Setting Screen 3: Setting Confirmation (OUT)

[Tips]

To cancel a selection, press the [SEL] key, not [ENT] key. With the press of the [SEL] key, the cancellation takes effect and the screen is switched to the "Menu screen 1".

7. Press the [SEL] key to display the "Menu screen 1".

Chapter 6 Error Message and Troubleshooting

6.1 Error Message

The following are to be performed in the event of an error in this system.

- The “ALARM” lamp comes on.
- Alarm buzzer comes on.
- The “Alarm Display screen” is displayed on the LCD screen.
- Error signal is issued through external communication.
(See section 8.1.2 “Communication specification” in Chapter 8 Appendix for details.)
- This system is brought to a stop forcefully according to error types.

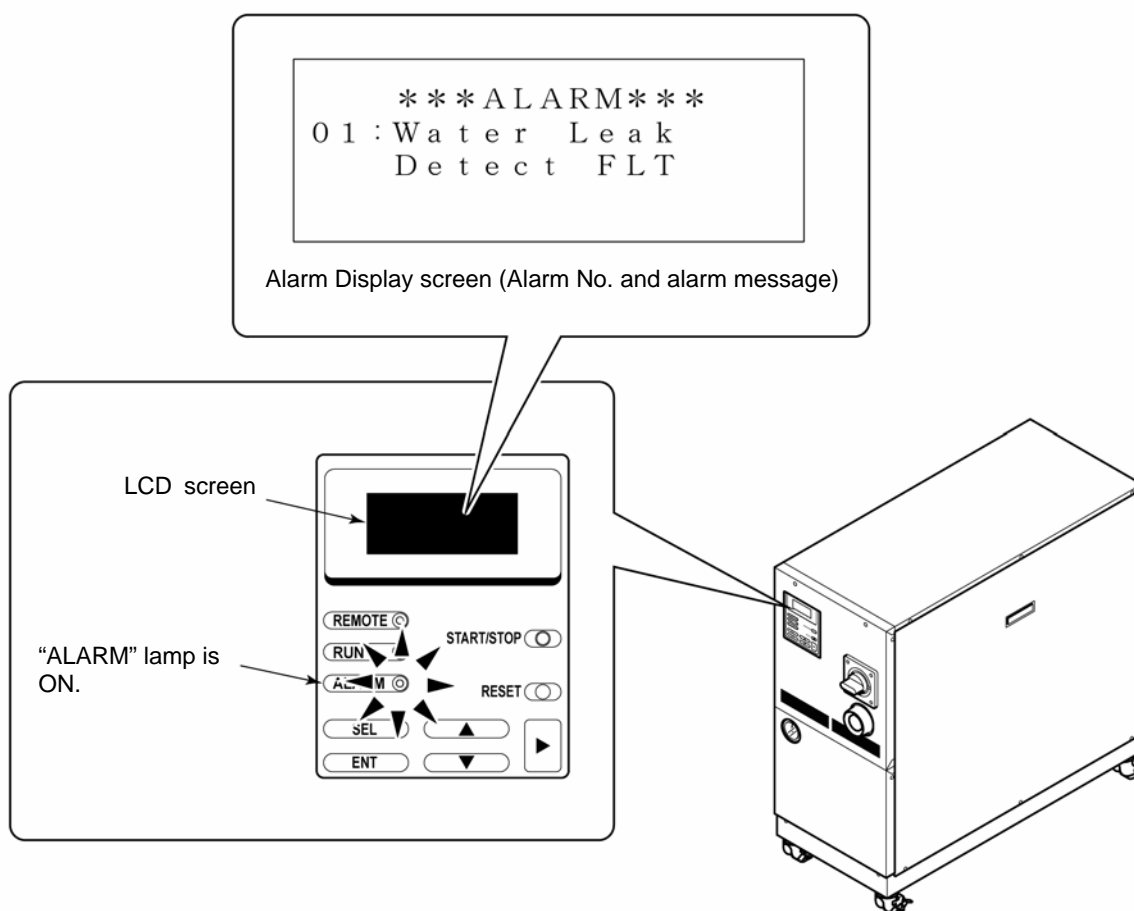

Figure 6-1 Error Occurrence

6.2 Troubleshooting

The procedure for error recovery varies with alarm types.

- Alarm Code.01 to 20, 22, 24, 25:
Eliminate the error cause. Press the [RESET] key on the operation display panel or power cycle the main breaker to enable error recovery to take effect.
- Alarm Code.21, 28:
Eliminate the error cause, and power cycle the main breaker to enable error recovery to take effect.
- Alarm Code.23, 26, 27:
Automatic error recovery is implemented upon elimination of the error.
- Alarm Code.24, 26, 27:
This is an alarm for accessories (optional).
No alarm of this type is issued if the system is outfitted with no accessories.
- Alarm Code.25, 28:
This alarm is only for HRZ010-W*S.

Table 6-1 Troubleshooting (1/2)

Code	Error message	System condition	Cause	Remedies
01	Water Leak Detect FLT	Stop	The fluid is pooled at the base of this system.	Check for fluid leak.
02	Incorrect Phase Error FLT	Stop	The power phase rotation is wrong.	Check that a proper connection is established between the power cable and main breaker of this system.
03	RFGT High Press FLT	Stop	The pressure of the refrigerant circuit exceeded the specified value.	Check that facility water is being supplied to this system.
04	CPRSR Overheat FLT	Stop	The temperature in the compressor was excessive.	Check that facility water is being supplied to this system.
05	Reservoir Low Level FLT	Stop	An insufficient amount of the circulating fluid is observed in the tank.	Replenish the circulating fluid.
06	Reservoir Low Level WRN	Continued	An insufficient amount of the circulating fluid is observed in the tank.	Replenish the circulating fluid.
07	Reservoir High Level WRN	Continued	An excessive amount of the circulating fluid is observed in the tank.	Drain the circulating fluid.
08	Temp. Fuse Cutout FLT	Stop	The circulating fluid tank was raised in temperature.	Check the load specification. Replacement of the thermal fuse is required. Call the supplier for service.
09	Reservoir High Temp. FLT	Stop	The temperature of the circulating fluid exceeded the specified value.	Check the load specification.
11	Reservoir High Temp. WRN	Continued	The temperature of the circulating fluid exceeded your specified value.	Reset the setting temperature.

Table 6-1 Troubleshooting (2/2)

Code	Error message	System condition	Cause	Remedies
12	Return Low Flow FLT	Stop	The flow rate of the circulating fluid falls short of 6L/min.	Check that the external valve is opened. Prepare a thicker external pipe or install bypass piping.
13	Return Low Flow WRN	Continued	The flow rate in this system falls short of your specified value.	Reset the setting flow rate.
14	Heater Breaker Trip FLT	Stop	The breaker for the heater power line was tripped.	Check that the power supply to this system is compliant with the specification.
15	Pump Breaker Trip FLT	Stop	The breaker for the circulating pump power line was tripped.	Check that the power supply to this system is compliant with the specification.
16	CPRSR Breaker Trip FLT	Stop	The breaker for the compressor power line was tripped.	Check that the power supply to this system is compliant with the specification.
17	Interlock Fuse Cutout FLT	Stop	An overcurrent was passed through the control circuit.	Contact the system supplier for request of inspection and repair.
18	DC Power Fuse Cutout WRN	Continued	An overcurrent was passed through the solenoid valve (optional).	Contact the system supplier for request of inspection and repair.
19	FAN Motor Stop WRN	Continued	The ventilating fan came to a stop.	Check that the air vent on the back of the system is not blocked off.
20	Internal Pump Time Out WRN	Continued	The internal pump was under conditions of continuous operation over a specified time.	Check for fluid leak from circulating fluid piping in your system.
21	Controller Error FLT	Stop	An error was detected in the control system.	Contact the system supplier for request of inspection and repair.
22	Memory Data Error FLT	Stop	An error was detected in data stored in the controller of this system.	Contact the system supplier for request of inspection and repair.
23	Communication Error WRN	Continued	An interruption of serial communication occurred between this system and your system.	Check that a signal is being issued from your system. Check for disconnection of the communication connector from this system.
24	DI Low Level WRN	Continued	Electical resistivity of the circulating fluid falls short of your specified value.	Lower the setting for resistivity. Replacement of the DI filter is required.
25	Pump Inverter Error FLT	Stop	An error was detected in the system inverter.	Contact the system supplier for request of inspection and repair.
26	DNET Comm. Error WRN	Continued	DeviceNet communication was disconnected between this system and the customer's system.	Check that a signal is being issued from your system. Check for disconnection of the communication connector from this system.
27	DNET Comm. Erroe FLT	Stop	An error was detected in the DeviceNet communication system.	Contact the system supplier for request of inspection and repair.
28	CPRSR INV Error FLT	Stop	An error was detected in the inverter for compressor.	Contact the system supplier for request of inspection and repair.

Chapter 7 System Maintenance

7.1 Water Quality Management

⚠ CAUTION



Only designated circulating fluid is permitted to use for this system. Potential system failure and fluid leak may occur if disregarded, which results in electric shock, ground fault, and freeze. Be sure to use fresh water (tap water) compliant with water quality standards in the table below for ethylene glycol aqueous solution and facility water.

Table 7-1 Water Quality Standards for Fresh Water (Tap Water)

	Substance	Facility water spec.	Circulating water spec.
Standards	pH (25°C)	6.5 to 8.2	6.0 to 8.0
	Electrical conductivity (25°C) (μs/cm) *Circulating fluid 1 to 500	100 to 800	0.5 to 300
	Chloride ion (mgCl-/L)	Max. 200	Max.50
	Sulfate ion (mgSO ₄ ²⁻ /L)	Max.200	Max.50
	Acid consumption (pH4.8) (mgCaCO ₃ /L)	Max.100	Max.50
	Total hardness (mgCaCO ₃ /L)	Max.200	Max.70
	Calcium hardness (mgCaCO ₃ /L)	Max.150	Max.50
	Ionic silica (mgSiO ₂ /L)	Max.50	Max.30
	Iron (mgFe/L)	Max.1.0	Max.0.3
	Copper (mgCu/L)	Max.0.3	Max.0.1
	Sulfide ion (mgS ²⁻ /L)	Not be detected	
	Ammonium ion (mgNH ₄ ⁺ /L)	Max.1.0	Max.0.1
	Residual chlorine (mgCl/L)	Max.0.3	Max.0.3
	Free carbon dioxide (mgCO ₂ /L)	Max.4.0	Max.4.0
	Filtering (μm)	Max.5	

* According to the Water quality guideline for refrigeration air-conditioning equipment: JRA-GL-02-1994

⚠ CAUTION



If the periodic inspection finds a nonconforming substance in the facility water, clean the facility water circuit and recheck the quality of the facility water.

7.2 Inspection and Cleaning

⚠ WARNING



- Do not touch any electrical parts with wet hands. Keep wet hands away from electrical parts. Potential electric shock can occur if disregarded.
- Keep this system from water. Potential electric shock or fire can occur if disregarded.

⚠ WARNING



If the inspection and cleaning require the removal of the panel, be sure to re-attach the panel upon completion. Potential personal injury or electric shock may occur if operated with the panel opened or removed.

7.2.1 Daily inspection

Table 7-2 Daily Inspection

Inspection item	Inspection method	
Installation condition	Check of the condition of system installation	No heavy object is placed on this system. This system should not be subjected to external force.
		Temperature and humidity fall within the specified range.
Fluid leak	Check of the piping connector section	No leak of facility water and circulating fluid from the piping connector section
Fluid level	Reading of the level of the circulating fluid	Level falls within the circulating fluid specified level between “High” and “Low”.
Operation display panel	Display check	Clarity of letters and numbers on the LCD display should be assured.
	Function check	[RUN] lamp is ON.
Circulating fluid temperature	Confirm the reading on the LCD screen	Temperature should be within setpoint.
Refrigerant pressure	Reading of the refrigerant pressure gauge	Pressure falls within the 0.3 to 1.0Mpa(45 to 145PSI) range.(HRZ00*-L2) Pressure falls within the 0.5 to 2.0Mpa(75 to 290PSI) range.(All other Models)
Discharge pressure of circulating fluid	Confirm the reading on the LCD screen	Reading should not have deviated much from last inspection.
Circulating fluid flow rate	Confirm the reading on the LCD screen	Reading should not have deviated much from last inspection.
Operating condition	Operating condition check	No abnormal noise, vibration, odor and smoke
Facility water	Check of the facility water	Temperature, flow rate and pressure fall within the specified range.
Circulating fluid supply port cap	Check by providing manual tightening	No looseness

7.2.2 Quarterly inspection



⚠ WARNING	
	<p>Quarterly inspection requires an advance lockout/tagout of this system. See section 1.5.3 “Lockout/Tagout” in “Chapter 1 Safety” for details.</p>

Table 7-3 Quarterly Inspection

Inspection item	Inspection method
Circulating fluid	Circulating fluid is to be drained for check. Fluid should be free of particles, moisture ^{*1} and foreign substances.
	For ethylene glycol solution, confirm that the concentration falls within the specified range.
	Recommended to replace the water.
Facility water	Facility water quality should fall within the standards specified.
Ventilation hole and electrical parts	No particles and dust should be present.

CAUTION	
	<p>Moisture trapped in the fluorinated fluid (*1) freezes in the heat exchanger element and piping, which may lead to system failure.</p>

7.3 Storage

The following should be performed for system long-term storage.

- 1.** Drain the circulating fluid. See section 7.3.1 “Draining of circulating fluid out of tank” for details.
- 2.** Drain the facility water. See section 7.3.2 “Draining of facility water” for details.
- 3.** Cover the system with a plastic sheet for storage.

7.3.1 Draining of circulating fluid out of tank

CAUTION



- Use the clean container for circulating fluid recovery. Reuse of the recovered circulating fluid with contaminated will cause insufficient cooling and system failure
- Be sure to wait until the circulating fluid obtains room temperature for its draining. Potential burns and dew intrusion may occur if disregarded.

1. Prepare the container for circulating fluid recovery at the back of this system.

2. Connect the drain hoses to the main and sub tank drain ports each. Insert the tip of the hose into the container.

- Prepare a drain hose (Rc3/8-diameter) on your responsibility.

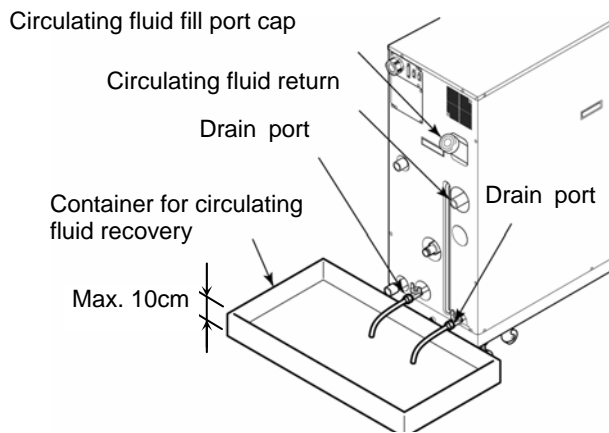



Figure 7-1 Container for Circulating Fluid Recovery

3. Remove the cap of the circulating fluid fill port.

4. Open the valves of the main and sub tank drain ports to drain the circulating fluid.

5. Apply air purge from the the circulating fluid return to push the circulating fluid remaining in the heat exchange back in the tank and drain it.

CAUTION



If the recovered circulating fluid is contaminated by foreign substances, completely remove them. Do not reuse contaminated fluid.
Potential insufficient cooling, system failure and froth in the circulating fluid may occur if disregarded.

CAUTION



Recovered circulating fluid must be sealed in a container to prevent contamination from moisture or foreign substances.
Stored in a cool, dark place.
Keep it from flame.

6. Upon completion of fluid draining, close the valves of the main and sub tank drain ports.

7. Add plugs to seal off ports on the rear of this system.

- See section 7.3.2 “Draining of facility water” for plug attachment.

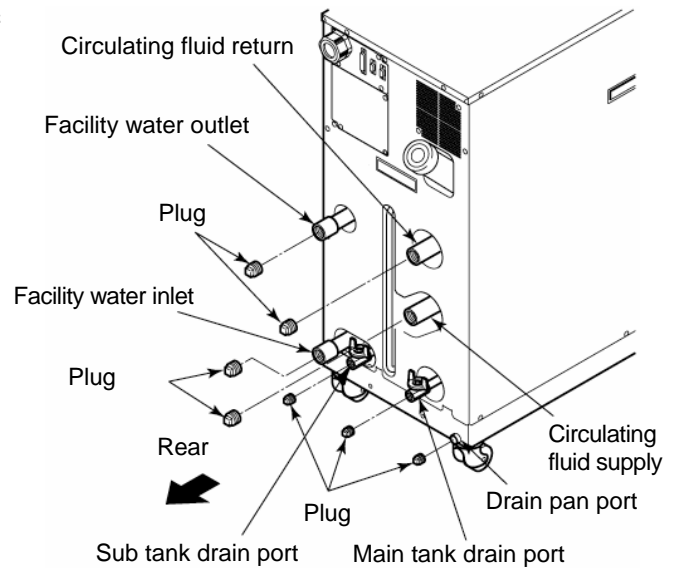



Figure 7-2 Plug Attachment

7.3.2 Draining of facility water

⚠ CAUTION



Be sure to drain the facility water only when it is at room temperature. Trapped fluid inside the system can still be hot. Potential burns can occur if disregarded.

1. Place the drain pan underneath the piping connections on the rear of this system.

- A 7L-capacity or bigger drain pan is required.

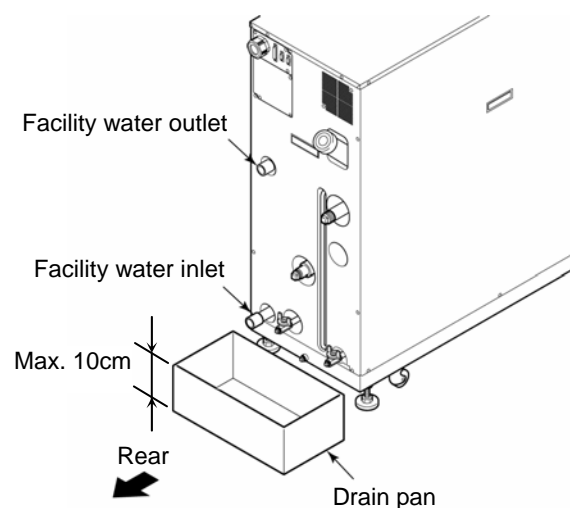

Figure 7-3 Drain Pan Attachment

- 2.** Remove facility water piping.
 - Remove the joints such as unions if present.
-

- 3.** Drain the facility water using the facility water inlet port.

7.4 Periodic Replacement Parts

Replacement of consumables listed in the following table is recommended.
Contact the system supplier for request of part replacement.

Table 7-4 Periodic Replacement Part List

Part	Recommended replacement cycle
Internal pump	Every 3 yrs
Circulating pump	Every 3 yrs
Ventilating fan	Every 3 yrs
Inverter Coolong Fan	Every 3 yrs

* Note: A replacement cycle may vary with your usage condition.

Chapter 8 Appendix

8.1 Specification

8.1.1 System specification

■ Specification for fluorinated fluid (low temperature)

Table 8-1 Specification for Fluorinated Fluid (Low Temperature)

Model		HRZ001-L	HRZ002-L	HRZ004-L	HRZ008-L
Cooling method		Water cooled refrigerant			
Cooling capacity ^{*1} (50Hz/60Hz)	kW	1.0 (At -10°C)	2.0 (At -10°C)	4.0 (At -10°C)	8.0 (At -10°C)
Operating temperature range	°C	-20 to 40			
Temperature stability	°C	±0.1 ^{*2}			
Circulating fluid		Galden [®] HT135 ^{*3} Fluorinert [™] FC-3283 ^{*3}			
		(No intrusion of foreign body)			
Refrigerant		HFC404A (CFC Free), (GWP:3784)			
Pump capacity ^{*4} (50Hz/60Hz)	MPa	0.45 /0.65 (At 20L/min) (65 / 95 [PSIG] At 5.3[gal/min])			0.65 /0.95 (At 30L/min) (94 / 138 [PSIG] At 8[gal/min])
Main Tank capacity ^{*5}	L	Approx.15 (4 [gal])			Approx.22 (5.8 [gal])
Sub Tank capacity ^{*6}	L	Approx.16 (4.2 [gal])			Approx.17 (4.5[gal])
Circulating fluid port		Rc 3/4			
Facility water	°C /MPa	10 to 25 / 0.3 to 0.7 (45 to 100 [PSIG])			
Required flow of facility water ^{*9} (50Hz/60Hz)	L/min	5/5 (1.3/1.3[gal/min])	6/6 (1.6/1.6[gal/min])	15/22 (4.0/5.8[gal/min])	18/23 (4.8/6.0[gal/min])
Facility water port		Rc 1/2			
Power supply		3-phase 50/60Hz AC200/200 to 208V±10%			
Main breaker size	A	30			60
Dimensions ^{*7}	mm	W380×D870×H950 (W14.96×D34.25×H37.40 [inch])			W415×D1080× H1075 (W16.34×D42.52 xH42.32 [inch])
Weight ^{*8}	kg	170 (375 [lbs])		175 (386 [lbs])	275 (606 [lbs])
Communication		Serial RS-485 (Dsub-9pin), Contact signal (Dsub-25pin)			

*1: The capacity is derived under the conditions that the facility water temp. is 25°C and that the circulating fluid flow rate is obtained at a specified flow rate of pump capacity. Applied to 50 / 60Hz.

*2: This is a system output temperature, with flow rate defined in pump capacity secured, when stabilized with no disturbance. Its upper limit may be violated if an insufficient amount of the circulating fluid is present or a disturbance to flow rate is observed.

*3: Galden[®] is a registered trademark of Solvay Solexis, and Fluorinert[™] is a trademark of U.S. 3M.

*4: The capacity is derived at the Outlet of this system when the circulating fluid temp. is at 20°C.

*5: This is a minimum amount of the fluid for operation of the Thermo Chiller outfitted with internal piping and heat exchanger in this system. Circulating fluid temp.: 20°C

*6: This is an auxiliary space with a main tank capacity excluded. Available for circulating fluid recovery from external piping and backup supply.

*7: This is the dimensions of panels, which is derived without protrusions such as a breaker handle.

*8: This is the mass of the system when it contains no circulating fluid.

*9: Facility water temp. is 25°C. There is required flow when adding load described on cooling capacity.

■ Specification for fluorinated fluid (high temperature)

Table 8-2 Specification for Fluorinated Fluid (High Temperature)

Model		HRZ001-H	HRZ002-H	HRZ004-H	HRZ008-H
Cooling method		Water cooled refrigerant			
Cooling capacity ^{*1} (50Hz/60Hz)	kW	1.0 (At 20°C)	2.0 (At 20°C)	4.0 (At 20°C)	8.0 (At 20°C)
Operating temperature range	°C	20 to 90			
Temperature stability	°C	±0.1 ^{*2}			
Circulating fluid		Galden [®] HT200 ^{*3} Fluorinert [™] FC-40 ^{*3}			
		(No intrusion of foreign body)			
Refrigerant		HFC404A (CFC Free), (GWP:3784)			
Pump capacity ^{*4} (50Hz/60Hz)	MPa	0.40 / 0.60 (At 20L/min) (58 / 87 [PSIG] At 5.3[gal/min])		0.45 / 0.65 (At 20L/min) (65 / 94 [PSIG] At 5.3[gal/min])	
Main Tank capacity ^{*5}	L	Approx.12 (3.2 [gal])		Approx.15 (4 [gal])	
Sub Tank capacity ^{*6}	L	Approx.15 (4 [gal])		Approx.16 (4.2 [gal])	
Circulating fluid port		Rc 3/4			
Facility water	°C/MPa	10 to 25 / 0.3 to 0.7 (45 to 100 [PSIG])			
Required flow of facility water ^{*9} (50Hz/60Hz)	L/min	3/4 (0.8/1.1[gal/min])	5/6 (1.3/1.6[gal/min])	9/10 (2.4/2.6[gal/min])	13/14 (3.4/3.7[gal/min])
Facility water port		Rc 1/2			
Power supply		3-phase 50/60Hz AC200/200 to 208V±10%			
Main breaker size	A	20		30	
Dimensions ^{*7}	mm	W380×D870×H860 (W14.96xD34.25xH33.86 [inch])		W380×D870×H950 (W14.96xD34.25xH37.40 [inch])	
Weight ^{*8}	kg	145 (320 [lbs])		170 (375 [lbs])	
Communication		Serial RS-485 (Dsub-9pin) , Contact signal (Dsub-25pin)			

*1: The capacity is derived under the conditions that the facility water temp. is 25°C and that the circulating fluid flow rate is obtained at a specified flow rate of pump capacity. Applied to 50 / 60Hz.
 *2: This is a system output temperature, with flow rate defined in pump capacity secured, when stabilized with no disturbance. Its upper limit may be violated if an insufficient amount of the circulating fluid is present or a disturbance to flow rate is observed.
 *3: Galden[®] is a registered trademark of Solvay Solexis, and Fluorinert[™] is a trademark of U.S. 3M.
 *4: The capacity is derived at the Outlet of this system when the circulating fluid temp. is at 20°C.
 *5: This is a minimum amount of the fluid for operation of the Thermo Chiller outfitted with internal piping and heat exchanger in this system. Circulating fluid temp.: 20°C
 *6: This is an auxiliary space with a main tank capacity excluded. Available for circulating fluid recovery from external piping and backup supply.
 *7: This is the dimensions of panels, which is derived without protrusions such as a breaker handle.
 *8: This is the mass of the system when it contains no circulating fluid.
 *9: Facility water temp. is 25°C. There is required flow when adding load described on cooling capacity.

■ Specification for fluorinated fluid (wide temperature)

Table 8-3 Specification for Fluorinated Fluid (Wide Temperature)

Model		HRZ002-W	HRZ008-W
Cooling method		Water cooled refrigerant	
Cooling capacity ^{*1} (50Hz/60Hz)	kW	2.0 (At 20°C)	8.0 (At 20°C)
Operating temperature range	°C	-20 to 90	
Temperature stability	°C	±0.1 ^{*2}	
Circulating fluid		Galden [®] HT135 ^{*3} Fluorinert [™] FC-3283 ^{*3} (-20 to 40°C) Galden [®] HT200 ^{*3} Fluorinert [™] FC-40 ^{*3} (20 to 90°C) (No intrusion of foreign body)	
Refrigerant		HFC404A (CFC Free), (GWP:3784)	
Pump capacity ^{*4} (50Hz/60Hz)	MPa	0.45 / 0.65 (At 20L/min) (65 / 94 [PSIG] At 5.3[gal/min])	
Main Tank capacity ^{*5}	L	Approx.15 (4 [gal])	
Sub Tank capacity ^{*6}	L	Approx.16 (4.2 [gal])	
Circulating fluid port		Rc 3/4	
Facility water	°C/MPa	10 to 25 / 0.3 to 0.7 (45 to 100 [PSIG])	
Required flow of facility water ^{*9} (50Hz/60Hz)	L/min	6/7 (1.6/1.8[gal/min])	13/14 (3.4/3.7[gal/min])
Facility water port		Rc 1/2	
Power supply		3-phase 50/60Hz AC200/200 to 208V±10%	
Main breaker size	A	30	
Dimensions ^{*7}	mm	W380×D870×H950(W14.96xD34.25xH37.40[inch])	
Weight ^{*8}	kg	170 (375 [lbs])	
Communication		Serial RS-485 (Dsub-9pin) , Contact signal (Dsub-25pin)	

*1: The capacity is derived under the conditions that the facility water temp. is 25°C and that the circulating fluid flow rate is obtained at a specified flow rate of pump capacity. Applied to 50 / 60Hz.

*2: This is a system output temperature, with flow rate defined in pump capacity secured, when stabilized with no disturbance. Its upper limit may be violated if an insufficient amount of the circulating fluid is present or a disturbance to flow rate is observed.

*3: Galden[®] is a registered trademark of Solvay Solexis, and Fluorinert[™] is a trademark of U.S. 3M.

*4: The capacity is derived at the Outlet of this system when the circulating fluid temp. is at 20°C.

*5: This is a minimum amount of the fluid for operation of the Thermo Chiller outfitted with internal piping and heat exchanger in this system. Circulating fluid temp.: 20°C

*6: This is an auxiliary space with a main tank capacity excluded. Available for circulating fluid recovery from external piping and backup supply.

*7: This is the dimensions of panels, which is derived without protrusions such as a breaker handle.

*8: This is the mass of the system when it contains no circulating fluid.

*9: Facility water temp. is 25°C. There is required flow when adding load described on cooling capacity.

■ Specification for ethylene glycol solution (low temperature)

Table 8-4 Specification for Ethylene Glycol Aqueous Solution (Low Temperature)

Model		HRZ001-L1	HRZ002-L1	HRZ004-L1	HRZ008-L1
Cooling method		Water cooled refrigerant			
Cooling capacity ^{*1} (50Hz/60Hz)	kW	1.0 (At -10°C)	2.0 (At -10°C)	4.0 (At -10°C)	8.0 (At -10°C)
Operating temperature range	°C	-20 to 40			
Temperature stability	°C	±0.1 ^{*2}			
Circulating fluid		Ethylene glycol solution 60% ^{*3} (No intrusion of foreign body)			
Refrigerant		HFC404A (CFC Free), (GWP:3784)			
Pump capacity ^{*4} (50Hz/60Hz)	MPa	0.25 / 0.40 (At 20L/min) (36 / 58 [PSIG] At 5.3gal/min)			
Main Tank capacity ^{*5}	L	Approx.15 (4 [gal])			Approx.22 (5.8 [gal])
Sub Tank capacity ^{*6}	L	Approx.16 (4.2 [gal])			Approx.17 (4.5 [gal])
Circulating fluid port		Rc 3/4			
Facility water	°C/MPa	10 to 25 / 0.3 to 0.7 (45 to 100 [PSIG])			
Required flow of facility water ^{*9} (50Hz/60Hz)	L/min	5/5 (1.3/1.3[gal/min])	6/6 (1.6/1.6[gal/min])	15/22 (4.0/5.8[gal/min])	18/23 (4.8/6.0[gal/min])
Facility water port		Rc 1/2			
Power supply		3-phase 50/60Hz AC200/200 to 208V±10%			
Main breaker size	A	30			60
Dimensions ^{*7}	mm	W380×D870×H950 (W14.96×D34.25×H37.40[inch])			W415×D1080× H1075 (W16.34×D42.52× H42.32 [inch])
Weight ^{*8}	kg	170 (375 [lbs])		175 (386 [lbs])	275 (606 [lbs])
Communication		Serial RS-485 (Dsub-9pin) , Contact signal (Dsub-25pin)			

*1: The capacity is derived under the conditions that the facility water temp. is 25°C and that the circulating fluid flow rate is obtained at a specified flow rate of pump capacity. Applied to 50 / 60Hz.

*2: This is a system output temperature, with flow rate defined in pump capacity secured, when stabilized with no disturbance. Its upper limit may be violated if an insufficient amount of the circulating fluid is present or a disturbance to flow rate is observed.

*3: Pure ethylene glycol needs dilution with fresh water before use.
Ethylene glycol with additives such as preservatives is NOT available.

*4: The capacity is derived at the Outlet of this system when the circulating fluid temp. is at 20°C.

*5: This is a minimum amount of the fluid for operation of the Thermo Chiller outfitted with internal piping and heat exchanger in this system. Circulating fluid temp.: 20°C

*6: This is an auxiliary space with a main tank capacity excluded. Available for circulating fluid recovery from external piping and backup supply.

*7: This is the dimensions of panels, which is derived without protrusions such as a breaker handle.

*8: This is the mass of the system when it contains no circulating fluid.

*9: Facility water temp. is 25°C. There is required flow when adding load described on cooling capacity.

■ Specification for ethylene glycol solution (high temperature)

Table 8-5 Specification for Ethylene Glycol Aqueous Solution (High Temperature)

Model		HRZ001-H1	HRZ002-H1	HRZ004-H1	HRZ008-H1
Cooling method		Water cooled refrigerant			
Cooling capacity ^{*1} (50Hz/60Hz)	kW	1.0 (At 20°C)	2.0 (At 20°C)	4.0 (At 20°C)	8.0 (At 20°C)
Operating temperature range	°C	20 to 90			
Temperature stability	°C	±0.1 ^{*2}			
Circulating fluid		Ethylene glycol aqueous solution 60% ^{*3} (No intrusion of foreign body)			
Refrigerant		HFC404A (CFC Free), (GWP:3784)			
Pump capacity ^{*4} (50Hz/60Hz)	MPa	0.25 / 0.35 (At 20L/min) (36 / 51 [PSIG] At 5.3[gal/min])		0.25 / 0.40 (At 20L/min) (36 / 58 [PSIG] At 5.3[gal/min])	
Main Tank capacity ^{*5}	L	Approx.12 (3.2 [gal])		Approx.15 (4 [gal])	
Sub Tank capacity ^{*6}	L	Approx.15 (4 [gal])		Approx.16 (4.2[gal])	
Circulating fluid port		Rc 3/4			
Facility water	°C/MPa	10 to 25 / 0.3 to 0.7 (45 to 100 [PSIG])			
Required flow of facility water ^{*9} (50Hz/60Hz)	L/min	3/4 (0.8/1.1[gal/min])	5/6 (1.3/1.6[gal/min])	9/10 (2.4/2.6[gal/min])	13/14 (3.4/3.7[gal/min])
Facility water port		Rc 1/2			
Power supply		3-phase 50/60Hz AC200/200 to 208V±10%			
Main breaker size	A	20		30	
Dimensions ^{*7}	mm	W380×D870×H860 (W14.96xD34.25xH33.86 [inch])		W380×D870×H950 (W14.96xD34.25xH37.40 [inch])	
Weight ^{*8}	kg	145 (320 [lbs])		170 (375 [lbs])	
Communication		Serial RS-485 (Dsub-9pin), Contact signal (Dsub-25pin)			

*1: The capacity is derived under the conditions that the facility water temp. is 25°C and that the circulating fluid flow rate is obtained at a specified flow rate of pump capacity. Applied to 50 / 60Hz.

*2: This is a system output temperature, with flow rate defined in pump capacity secured, when stabilized with no disturbance. Its upper limit may be violated if an insufficient amount of the circulating fluid is present or a disturbance to flow rate is observed.

*3: Pure ethylene glycol needs dilution with fresh water before use.
Ethylene glycol with additives such as preservatives is NOT available.

*4: The capacity is derived at the Outlet of this system when the circulating fluid temp. is at 20°C.

*5: This is a minimum amount of the fluid for operation of the Thermo Chiller outfitted with internal piping and heat exchanger in this system. Circulating fluid temp.: 20°C

*6: This is an auxiliary space with a main tank capacity excluded. Available for circulating fluid recovery from external piping and backup supply.

*7: This is the dimensions of panels, which is derived without protrusions such as a breaker handle.

*8: This is the mass of the system when it contains no circulating fluid.

*9: Facility water temp. is 25°C. There is required flow when adding load described on cooling capacity.

■ Specification for ethylene glycol solution (wide temperature)

Table 8-6 Specification for Ethylene Glycol Aqueous Solution (Wide Temperature)

Model		HRZ002-W1	HRZ008-W1
Cooling method		Water cooled refrigerant	
Cooling capacity ^{*1} (50Hz/60Hz)	kW	2.0 (At 20°C)	8.0 (At 20°C)
Operating temperature range	°C	-20 to 90	
Temperature stability	°C	±0.1 ^{*2}	
Circulating fluid		Ethylene glycol aqueous solution 60% ^{*3} (No intrusion of foreign body)	
Refrigerant		HFC404A (CFC Free), (GWP:3784)	
Pump capacity ^{*4} (50Hz/60Hz)	MPa	0.25 / 0.40 (At 20L/min) (36 / 58 [PSIG] At 5.3[gal/min])	
Main Tank capacity ^{*5}	L	Approx.15 (4 [gal])	
Sub Tank capacity ^{*6}	L	Approx.16 (4.2 [gal])	
Circulating fluid port		Rc 3/4	
Facility water	°C/MPa	10 to 25 / 0.3 to 0.7 (45 to 100 [PSIG])	
Required flow of facility water ^{*9} (50Hz/60Hz)	L/min	5/7 (1.3/1.8[gal/min])	13/14 (3.4/3.7[gal/min])
Facility water port		Rc 1/2	
Power supply		3-phase 50/60Hz AC200/200 to 208V±10%	
Main breaker size	A	30	
Dimensions ^{*7}	mm	W380×D870×H950(W14.96xD34.25xH37.40 [inch])	
Weight ^{*8}	kg	170 (375 [lbs])	
Communication		Serial RS-485 (Dsub-9pin) , Contact signal (Dsub-25pin)	

*1: The capacity is derived under the conditions that the facility water temp. is 25°C and that the circulating fluid flow rate is obtained at a specified flow rate of pump capacity. Applied to 50 / 60Hz.
 *2: This is a system output temperature, with flow rate defined in pump capacity secured, when stabilized with no disturbance. Its upper limit may be violated if an insufficient amount of the circulating fluid is present or a disturbance to flow rate is observed.
 *3: Pure ethylene glycol needs dilution with fresh water before use.
 Ethylene glycol with additives such as preservatives is NOT available.
 *4: The capacity is derived at the Outlet of this system when the circulating fluid temp. is at 20°C.
 *5: This is a minimum amount of the fluid for operation of the Thermo Chiller outfitted with internal piping and heat exchanger in this system. Circulating fluid temp.: 20°C
 *6: This is an auxiliary space with a main tank capacity excluded. Available for circulating fluid recovery from external piping and backup supply.
 *7: This is the dimensions of panels, which is derived without protrusions such as a breaker handle.
 *8: This is the mass of the system when it contains no circulating fluid.
 *9: Facility water temp. is 25°C. There is required flow when adding load described on cooling capacity.

■ Specification for water (low temperature)

Table 8-7 Specification for water (Low Temperature)

Model		HRZ001-L2	HRZ002-L2	HRZ004-L2	HRZ008-L2
Cooling method		Water cooled refrigerant			
Cooling capacity ^{*1} (50Hz/60Hz)	kW	1.0 (At 20°C)	2.0 (At 20°C)	4.0 (At 20°C)	8.0 (At 20°C)
Operating temperature range	°C	10 to 40			
Temperature stability	°C	±0.1 ^{*2}			
Circulating fluid		Pure water / DI water ^{*3} (No intrusion of foreign body)			
Refrigerant		HFC134a (CFC Free), (GWP:1300)			
Pump capacity ^{*4} (50Hz/60Hz)	MPa	0.25 / 0.38 (At 20L/min) (36 / 55 [PSIG] At 5.3gal/min)			
Main Tank capacity ^{*5}	L	Approx.15 (4 [gal])			
Sub Tank capacity ^{*6}	L	Approx.16 (4.2 [gal])			
Circulating fluid port		Rc 3/4			
Facility water	°C/MPa	10 to 25 / 0.3 to 0.7 (45 to 100 [PSIG])			
Required flow of facility water ^{*9} (50Hz/60Hz)	L/min	5/5 (1.3/1.3[gal/min])	6/6 (1.6/1.6[gal/min])	15/22 (4.0/5.8[gal/min])	18/23 (4.8/6.0[gal/min])
Facility water port		Rc 1/2			
Power supply		3-phase 50/60Hz AC200/200 to 208V±10%			
Main breaker size	A	30			
Dimensions ^{*7}	mm	W380×D870×H950 (W14.96×D34.25×H37.40[inch])			
Weight ^{*8}	kg	170 (375 [lbs])			
Communication		Serial RS-485 (Dsub-9pin) , Contact signal (Dsub-25pin)			

*1: The capacity is derived under the conditions that the facility water temp. is 25°C and that the circulating fluid flow rate is obtained at a specified flow rate of pump capacity. Applied to 50 / 60Hz.

*2: This is a system output temperature, with flow rate defined in pump capacity secured, when stabilized with no disturbance. Its upper limit may be violated if an insufficient amount of the circulating fluid is present or a disturbance to flow rate is observed.

*3: Water quality of The Japan Refrigeration and Air Conditioning Industry Association (JRA GL-02-1994/Recirculating fluid of Cooling water system) shall be satisfied (See "7.1 Water Quality Management")
Additives such as preservative is NOT available. It not only deteriorates the performance, but also lead to cause failure.

*4: The capacity is derived at the Outlet of this system when the circulating fluid temp. is at 20°C.

*5: This is a minimum amount of the fluid for operation of the Thermo Chiller outfitted with internal piping and heat exchanger in this system. Circulating fluid temp.: 20°C

*6: This is an auxiliary space with a main tank capacity excluded. Available for circulating fluid recovery from external piping and backup supply.

*7: This is the dimensions of panels, which is derived without protrusions such as a breaker handle.

*8: This is the mass of the system when it contains no circulating fluid.

*9: Facility water temp. is 25°C. There is required flow when adding load described on cooling capacity.

■ Specification for fluorinated fluid (wide temperature with Inverter)

Table 8-8 Specification for Fluorinated Fluid (Wide Temperature with Inverter)

Model		HRZ010-WS
Cooling method		Water cooled refrigerant
Cooling capacity ^{*1} (50Hz/60Hz)	kW	10.0 (At 20°C)
Operating temperature range	°C	-20 to 90
Temperature stability	°C	±0.1 ^{*2}
Circulating fluid		Galden [®] HT135 ^{*3} Fluorinert [™] FC-3283 ^{*3} (-20 to 40°C) Galden [®] HT200 ^{*3} Fluorinert [™] FC-40 ^{*3} (20 to 90°C) (No intrusion of foreign body)
Refrigerant		HFC404A (CFC Free), (GWP:3784)
Pump capacity ^{*4} (50Hz/60Hz)	MPa	Max. 0.72 (At 20L/min) (104 [PSIG] At 5.3gal/min) with flow control function by VFD
Main Tank capacity ^{*5}	L	Approx.15 (4 [gal])
Sub Tank capacity ^{*6}	L	Approx.16 (4.2 [gal])
Circulating fluid port		Rc 3/4
Facility water	°C/MPa	10 to 30 / 0.3 to 0.7 (45 to 100 [PSIG])
Required flow of facility water ^{*9} (50Hz/60Hz)	L/min	15/15 (4.0/4.0[gal/min])
Facility water port		Rc 1/2
Power supply		3-phase 50/60Hz AC200/200 to 208V±10%
Main breaker size	A	30
Dimensions ^{*7}	mm	W380×D870×H950 (W14.96xD34.25xH37.40[inch])
Weight ^{*8}	kg	165 (364 [lbs])
Communication		Serial RS-485 (Dsub-9pin) , Contact signal (Dsub-25pin)

*1: The capacity is derived under the conditions that the facility water temp. is 25°C and that the circulating fluid flow rate is obtained at a specified flow rate of pump capacity. Applied to 50 / 60Hz.
 *2: This is a system output temperature, with flow rate defined in pump capacity secured, when stabilized with no disturbance. Its upper limit may be violated if an insufficient amount of the circulating fluid is present or a disturbance to flow rate is observed.
 *3: Galden[®] is a registered trademark of Solvay Solexis, and Fluorinert[™] is a trademark of U.S. 3M.
 *4: The capacity is derived at the Outlet of this system when the circulating fluid temp. is at 20°C.
 *5: This is a minimum amount of the fluid for operation of the Thermo Chiller outfitted with internal piping and heat exchanger in this system. Circulating fluid temp.: 20°C
 *6: This is an auxiliary space with a main tank capacity excluded. Available for circulating fluid recovery from external piping and backup supply.
 *7: This is the dimensions of panels, which is derived without protrusions such as a breaker handle.
 *8: This is the mass of the system when it contains no circulating fluid.
 *9: Facility water temp. is 25°C. There is required flow when adding load described on cooling capacity.

■ Specification for ethylene glycol solution (low temperature with Inverter)

Table 8-9 Specification for ethylene glycol solution (low temperature with Inverter)

Model		HRZ010-W1S
Cooling method		Water cooled refrigerant
Cooling capacity ^{*1} (50Hz/60Hz)	kW	10.0 (At 20°C)
Operating temperature range	°C	-20 to 90
Temperature stability	°C	±0.1 ^{*2}
Circulating fluid		Ethylene glycol aqueous solution 60% ^{*3} (No intrusion of foreign body)
Refrigerant		HFC404A (CFC Free), (GWP:3784)
Pump capacity ^{*4} (50Hz/60Hz)	MPa	Max. 0.40 (At 20L/min) (58[PSIG] At 5.3gal/min) with flow control function by VFD
Main Tank capacity ^{*5}	L	Approx.15 (4 [gal])
Sub Tank capacity ^{*6}	L	Approx.16 (4.2 [gal])
Circulating fluid port		Rc 3/4
Facility water	°C/MPa	10 to 30 / 0.3 to 0.7 (45 to 100 [PSIG])
Required flow of facility water ^{*9} (50Hz/60Hz)	L/min	15/15 (4.0/4.0[gal/min])
Facility water port		Rc 1/2
Power supply		3-phase 50/60Hz AC200/200 to 208V±10%
Main breaker size	A	30
Dimensions ^{*7}	mm	W380×D870×H950 (W14.96xD34.25xH37.40[inch])
Weight ^{*8}	kg	165 (364 [lbs])
Communication		Serial RS-485 (Dsub-9pin) , Contact signal (Dsub-25pin)

*1: The capacity is derived under the conditions that the facility water temp. is 25°C and that the circulating fluid flow rate is obtained at a specified flow rate of pump capacity. Applied to 50 / 60Hz.

*2: This is a system output temperature, with flow rate defined in pump capacity secured, when stabilized with no disturbance. Its upper limit may be violated if an insufficient amount of the circulating fluid is present or a disturbance to flow rate is observed.

*3: Pure ethylene glycol needs dilution with fresh water before use.
Ethylene glycol with additives such as preservatives is NOT available.

*4: The capacity is derived at the Outlet of this system when the circulating fluid temp. is at 20°C.

*5: This is a minimum amount of the fluid for operation of the Thermo Chiller outfitted with internal piping and heat exchanger in this system. Circulating fluid temp.: 20°C

*6: This is an auxiliary space with a main tank capacity excluded. Available for circulating fluid recovery from external piping and backup supply.

*7: This is the dimensions of panels, which is derived without protrusions such as a breaker handle.

*8: This is the mass of the system when it contains no circulating fluid.

*9: Facility water temp. is 25°C. There is required flow when adding load described on cooling capacity.

■ Specification for water (low temperature with Inverter)

Table 8-10 Specification for water (low temperature with Inverter)

Model		HRZ010-W2S
Cooling method		Water cooled refrigerant
Cooling capacity ^{*1} (50Hz/60Hz)	kW	9.0 (At 20°C)
Operating temperature range	°C	10 to 60
Temperature stability	°C	±0.1 ^{*2}
Circulating fluid		Pure water / DI water ^{*3} (No intrusion of foreign body)
Refrigerant		HFC404A (CFC Free), (GWP:3784)
Pump capacity ^{*4} (50Hz/60Hz)	MPa	Max. 0.38 (At 20L/min) (55[PSIG] At 5.3gal/min) with flow control function by VFD
Main Tank capacity ^{*5}	L	Approx.15 (4 [gal])
Sub Tank capacity ^{*6}	L	Approx.16 (4.2 [gal])
Circulating fluid port		Rc 3/4
Facility water	°C/MPa	10 to 30 / 0.3 to 0.7 (45 to 100 [PSIG])
Required flow of facility water ^{*9} (50Hz/60Hz)	L/min	15/15 (4.0/4.0[gal/min])
Facility water port		Rc 1/2
Power supply		3-phase 50/60Hz AC200/200 to 208V±10%
Main breaker size	A	30
Dimensions ^{*7}	mm	W380×D870×H950 (W14.96×D34.25×H37.40[inch])
Weight ^{*8}	kg	165 (364 [lbs])
Communication		Serial RS-485 (Dsub-9pin) , Contact signal (Dsub-25pin)

*1: The capacity is derived under the conditions that the facility water temp. is 25°C and that the circulating fluid flow rate is obtained at a specified flow rate of pump capacity. Applied to 50 / 60Hz.
 *2: This is a system output temperature, with flow rate defined in pump capacity secured, when stabilized with no disturbance. Its upper limit may be violated if an insufficient amount of the circulating fluid is present or a disturbance to flow rate is observed.
 *3: Water quality of The Japan Refrigeration and Air Conditioning Industry Association (JRA GL-02-1994/Recirculating fluid of Cooling water system) shall be satisfied (See “7.1 Water Quality Management”) Additives such as preservative is NOT available. It not only deteriorates the performance, but also lead to cause failure.
 *4: The capacity is derived at the Outlet of this system when the circulating fluid temp. is at 20°C.
 *5: This is a minimum amount of the fluid for operation of the Thermo Chiller outfitted with internal piping and heat exchanger in this system. Circulating fluid temp.: 20°C
 *6: This is an auxiliary space with a main tank capacity excluded. Available for circulating fluid recovery from external piping and backup supply.
 *7: This is the dimensions of panels, which is derived without protrusions such as a breaker handle.
 *8: This is the mass of the system when it contains no circulating fluid.
 *9: Facility water temp. is 25°C. There is required flow when adding load described on cooling capacity.

8.1.2 Communication specification

This section provides the general outline of communications utilized in this system. For detail specification, we provide a separate system manual “Communication Specification”, which is available through your local distributor.

■ Contact signal

Table 8-11 Contact Signal

Item	Specification	
Connector No.	P1	
Connector type (this system)	D-sub25P female connector	
Input signal	Insulation type	Photocoupler
	Rated input voltage	DC24V
	Used voltage range	DC 21.6V to 26.4V
	Rated input current	5mA TYP
	Input impedance	4.7kΩ
Open-collector output signal	Insulation type	Photocoupler
	Rated load voltage	DC24V
	Used load voltage range	DC 21.6V to 26.4V
	Max. load current	80mA
	Leakage current	Max. 0.1mA
	Surge protection	Diode
Contact output signal (Alarm)	Rated load voltage	Max. AC48V/ Max. DC24V
	Max. load current	AC/DC 500mA (resistance load)
Contact output signal (EMO)	Rated load voltage	Max. AC48V/ Max. DC24V
	Max. load current	AC/DC 800mA (resistance load, inductive load)

Circuit block diagram

■ **Serial RS-485**

Table 8-12 Serial RS-485

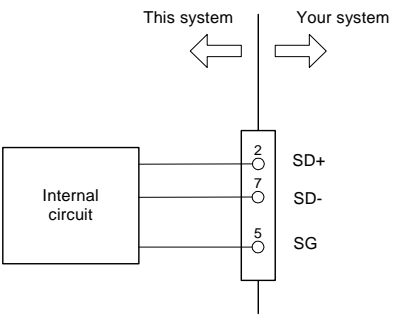
Item	Specification
Connector No.	P2
Connector type (this system)	D-sub9P female connector
Standard	EIA RS485
Protocol	Modicon Modbus
Circuit block diagram	 <p>The diagram shows an 'Internal circuit' box connected to a vertical D-sub9P female connector. Three lines connect the internal circuit to pins 2, 7, and 5 of the connector. Pin 2 is labeled 'SD+', pin 7 is labeled 'SD-', and pin 5 is labeled 'SG'. Above the connector, a vertical line represents the bus, with arrows pointing left labeled 'This system' and right labeled 'Your system'.</p>

8.1.3 Alarm signal selection

User can designate one alarm signal for contact signal. See section 5.3.9 “Initial Setting screen” for signal selecting.

The following table presents the setting-alarm relationship. The alarm signal is turned OFF if the designated alarm detected. (Alarm signal is ON if no alarm is detected.)

Table 8-13 Alarm signal selection

Setting	Alarm	Alarm
N/A	Alarm signal remains ON (closed) under normal circumstances.	-
Alarm1	Water Leak Detect FLT	01
Alarm2	Incorrect Phase Error FLT	02
Alarm3	RFGT High Press FLT	03
Alarm4	CPRSR Overheat FLT	04
Alarm5	Reservoir Low Level FLT	05
Alarm6	Reservoir Low Level WRN	06
Alarm7	Reservoir High Level WRN	07
Alarm8	Temp. Fuse Cutout FLT	08
Alarm9	Reservoir High Temp. FLT	09
Alarm10 ^{*1}	-	10
Alarm11	Reservoir High Temp. WRN	11
Alarm12	Return Low Flow FLT	12
Alarm13	Return Low Flow WRN	13
Alarm14	Heater Breaker Trip FLT	14
Alarm15	Pump Breaker Trip FLT	15
Alarm16	CPRSR Breaker Trip FLT	16
Alarm17	Interlock Fuse Cutout FLT	17
Alarm18	DC Power Fuse Cutout WRN	18
Alarm19	FAN Motor Stop WRN	19
Alarm20	Internal Pump Time Out WRN	20
Alarm21	Controller Error FLT	21
Alarm22	Memory Data Error FLT	22
Alarm23	Communication Error WRN	23
Alarm24 ^{*2}	DI Low Level WRN	24
Alarm25 ^{*3}	Pump Inverter Error FLT	25
Alarm26 ^{*2}	DNET Comm. Error WRN	26
Alarm27 ^{*2}	DNET Comm. Error FLT	27
Alarm28 ^{*3}	CPRSR Inverter Error FLT	28

● Example

With parameter “OUT” on the Initial Setting screen set to “Alarm1”, alarm “Water Leak Detect FLT” is detected, the alarm contact signal is switched to OFF (open).

*1: Alarm10 is assigned with no alarm. The alarm signal remains ON (closed) despite Alarm10 being specified.

*2: Alarms 24, 26 and 27 are alarms indicating accessories (optional).

*3: Alarms 25 and 28 are only for HRZ010-W*S. As other model is assigned with no alarm, the alarm signal always remains ON (closed).

8.2 Outer Dimensions

8.2.1 Part 1

HRZ001-H HRZ001-H1 HRZ002-H HRZ002-H1

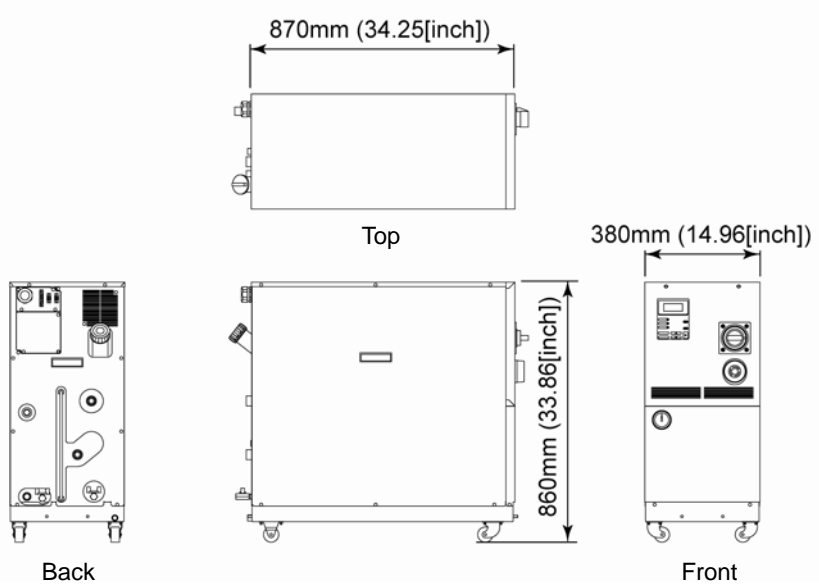

Figure 8-1 Outer Dimensions

8.2.2 Part 2

HRZ001-L HRZ002-L HRZ004-L HRZ008-L2
HRZ001-L1 HRZ002-L1 HRZ004-L1 HRZ008-H
HRZ001-L2 HRZ002-L2 HRZ004-L2 HRZ008-H1
HRZ002-W HRZ004-H HRZ008-W
HRZ002-W1 HRZ004-H1 HRZ008-W1
HRZ010-WS HRZ010-W1S HRZ010-W2S

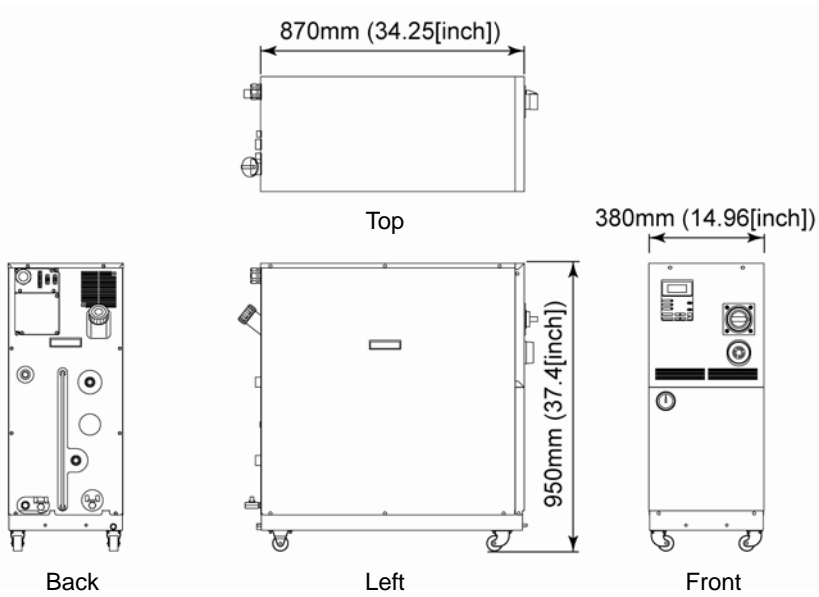

Figure 8-2 Outer Dimensions

8.2.3 Part 3

HRZ008-L HRZ008-L1

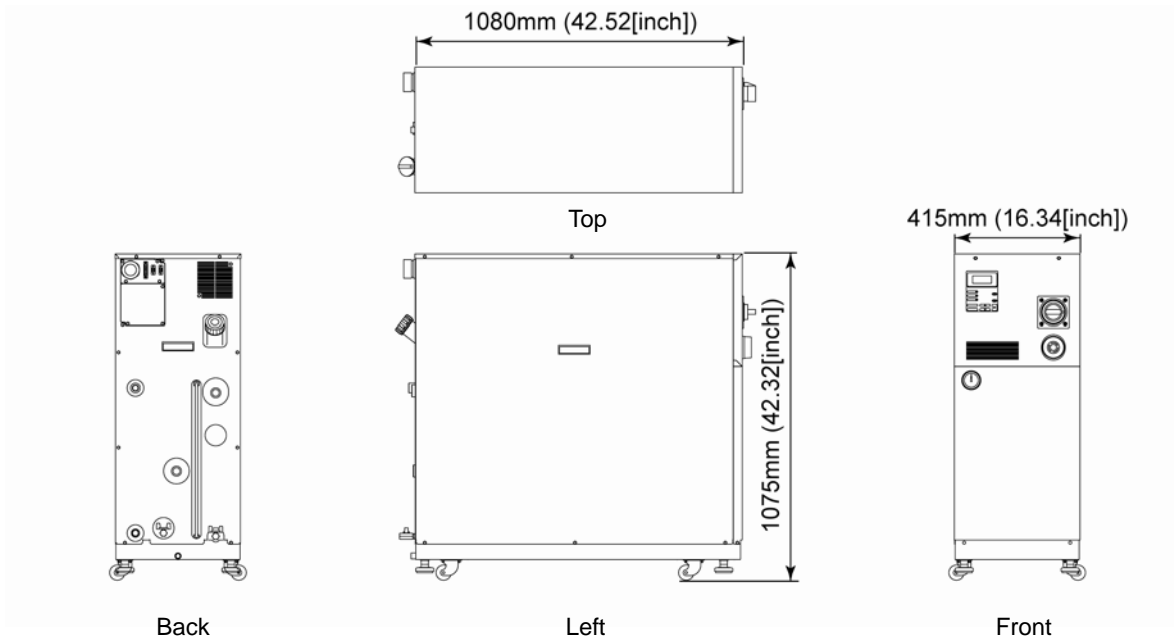

Figure 8-3 Outer Dimensions

8.3 Flow Chart

8.3.1 Part 1

HRZ001-H	HRZ002-H	HRZ004-H	HRZ008-H
HRZ001-H1	HRZ002-H1	HRZ004-H1	HRZ008-H1
HRZ002-W	HRZ008-W	HRZ002-W1	HRZ008-W1
	HRZ010-WS	HRZ010-W1S	HRZ010-W2S

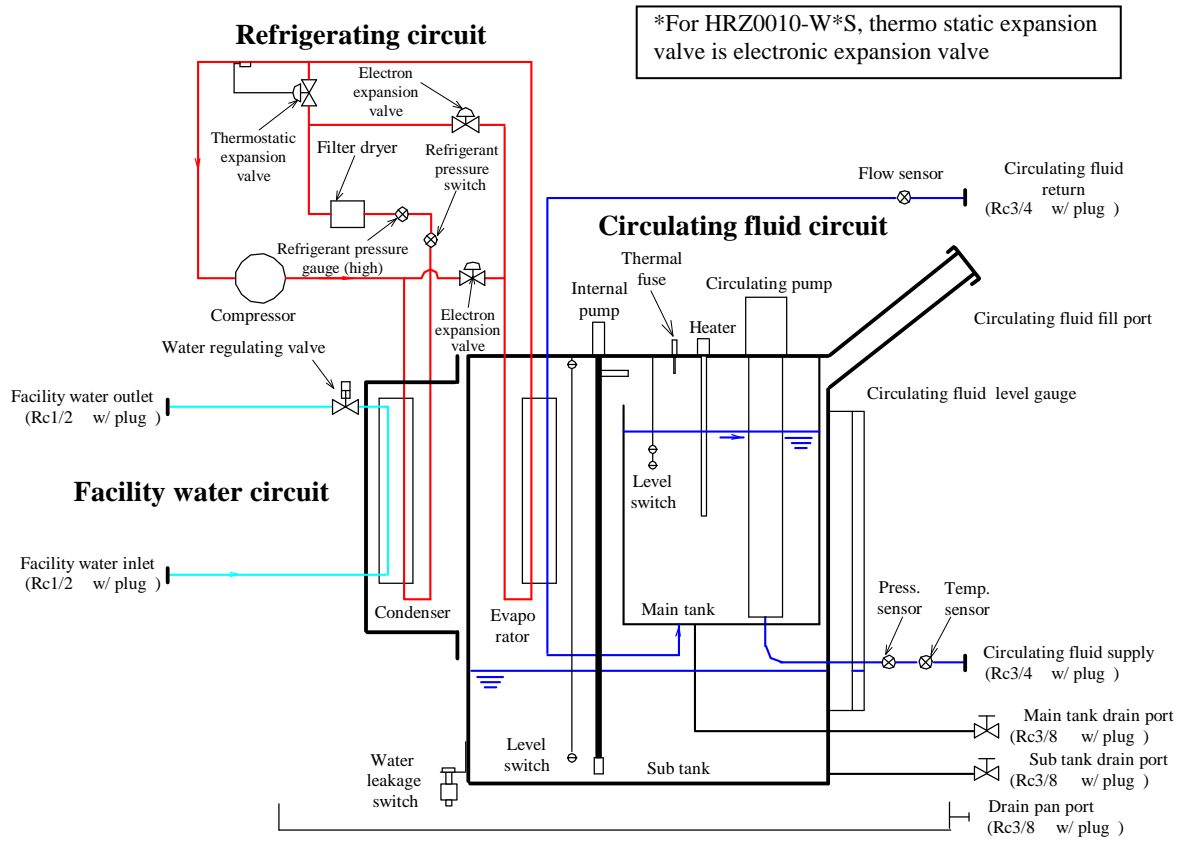

Figure 8-4 Flow Chart

8.3.2 Part 2

HRZ001-L	HRZ002-L	HRZ004-L	HRZ008-L
HRZ001-L1	HRZ002-L1	HRZ004-L1	HRZ008-L1
HRZ001-L2	HRZ002-L2	HRZ004-L2	HRZ008-L2

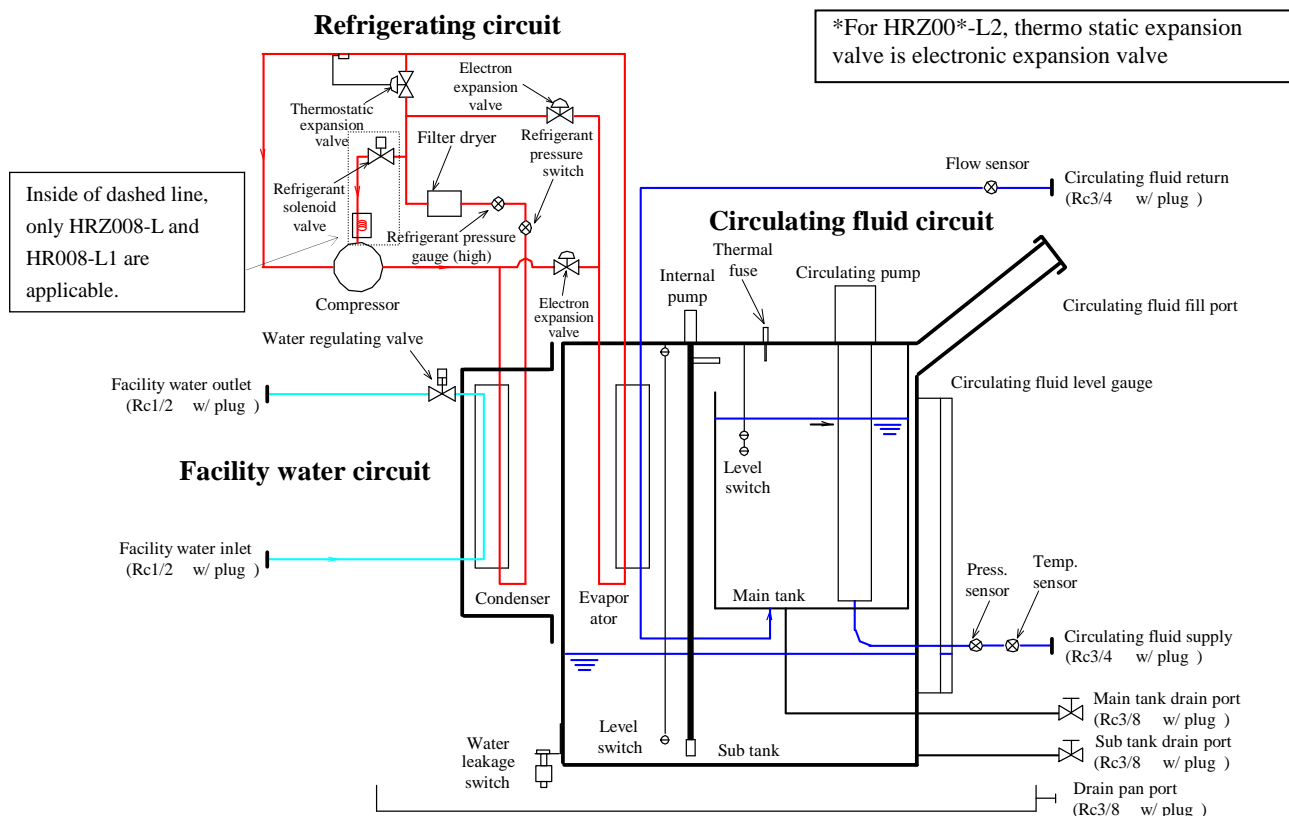

Figure 8-5 Flow Chart

8.4 Offset Function

Potential deviations in temperature between this system and your system may be concerned depending on the installation environment. The offset function falling into three types (MODE1 to 3) is assigned to calibrate deviations in temperature. See the following descriptions for the offset function. See section 5.3.9 “Initial Setting screen” for setting.

TEMP PV value, which is displayed on the Status screen, is output as circulating fluid temperature data in terms of communication.

● When MODE1 is selected

This mode is used to exercise temperature control to allow the discharge temperature of the circulating fluid to be “TEMP SP value + OFFSET value”. TEMP PV value denotes the discharge temperature of the circulating fluid.

E.g.: TEMP SP value: +20°C, OFFSET value: +2°C
→ Circulating fluid discharge temp.: +22°C, TEMP PV: +22°C

● When MODE2 is selected

This mode is used to exercise temperature control to allow the discharge temperature of the circulating fluid to be “TEMP SP value”. TEMP PV value denotes “Circulating fluid discharge temp. value + OFFSET value”.

E.g.: TEMP SP value: +20°C, OFFSET value: +2°C
→ Circulating fluid discharge temp.: +20°C, TEMP PV: +22°C

● When MODE3 is selected

This mode is used to exercise temperature control to allow the discharge temperature of the circulating fluid to be “TEMP SP value + OFFSET value”. TEMP PV value denotes “Circulating fluid discharge temp. value - OFFSET value”.

E.g.: TEMP SP value: +20°C, OFFSET value: +2°C
→ Circulating fluid discharge temp.: +20°C, TEMP PV: +20°C

● When OFF is selected

If no mode is selected, temperature control is conducted to allow the discharge temperature of the circulating fluid to be “TEMP SP value”.

8.4.1 Example of offset function

When the discharge temperature of the circulating fluid is at 30°C, heat is dissipated by 1°C to allow the circulating fluid in your system to be 29°C. Under the above condition, the following process is to be performed with the utilization of MODEs 1 to 3.

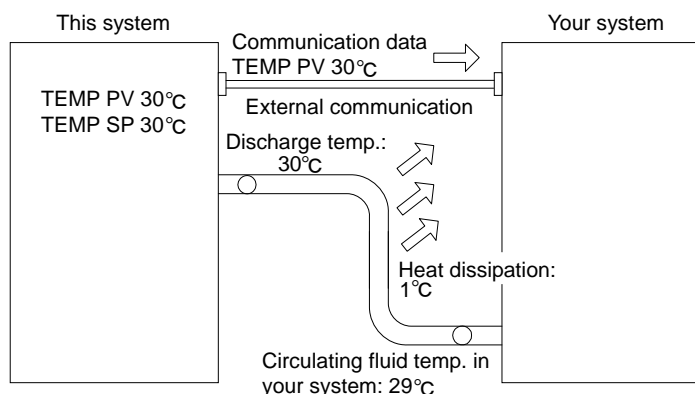

Figure 8-6 Example of Offset Function

■ When MODE1 is selected

This mode enables this system to exercise temperature control to obtain 31°C (TEMP SP value +OFFSET value), with OFFSET value set at 1°C. Once the discharge temperature of the circulating fluid becomes 31°C, 1°C-thermal dissipation is assured to allow the circulating fluid in your system to be 30°C. TEMP SP value is obtained for your system.

Note that “31°C” is recorded in TEMP PV and communication data.

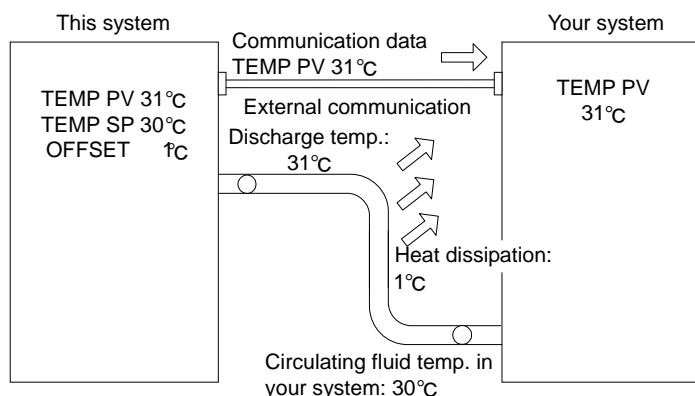

Figure 8-7 When MODE1 is selected

■ When MODE2 is selected

With OFFSET value set at -1°C, TEMP PV and communication data express “29°C” (circulating fluid discharge temp. value + OFFSET value) that agrees with the temperature of the circulating fluid in your system.

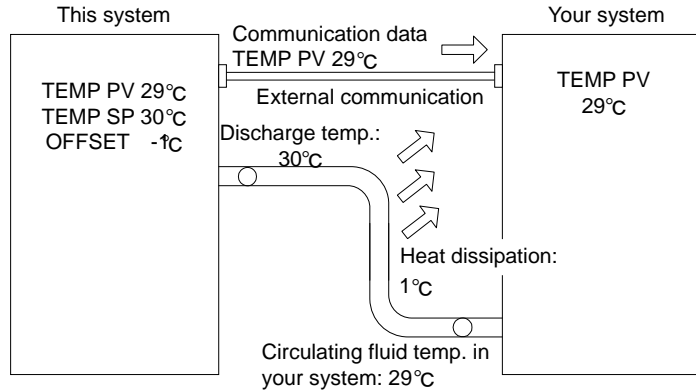

Figure 8-8 When MODE2 is selected

■ When MODE3 is selected

This mode enables this system to exercise temperature control to obtain 31°C (TEMP SP value +OFFSET value), with OFFSET value set at 1°C. Once the discharge temperature of the circulating fluid becomes 31°C, 1°C-thermal dissipation is assured to allow the circulating fluid in your system to be 30°C. TEMP SP value is obtained for your system. TEMP PV and communication data also express “30°C” (circulating fluid discharge temp. value - OFFSET value) that agrees with the temperature of the circulating fluid in your system.

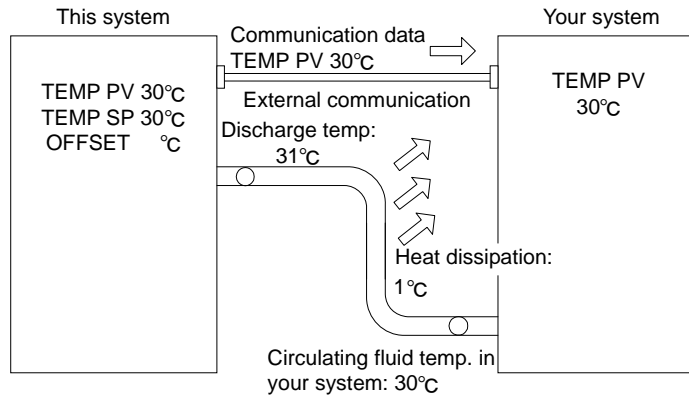

Figure 8-9 When MODE3 is selected

8.5 BAND/READY function

Sets BAND to TEMP SP value, and notifies TEMP PV value reaches within BAND range by the operation display panel or the communication.

See section “5.3.9 Initial Setting screen” on page 5-1, “5.3.11 Option screen” on page 5-1 for the procedure of the setting.

● When the setting is ON

Allows the setting of the BAND and REDY TIME. Allows the setting of the communication output.

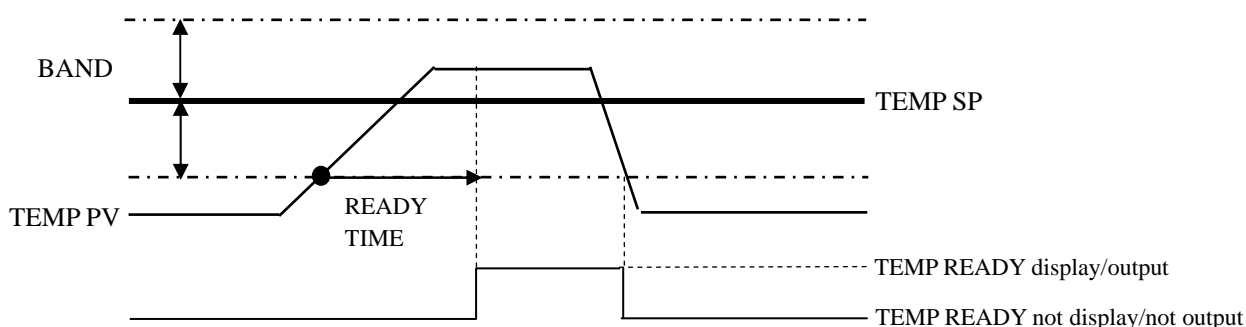

Figure 8-10 BAND/READY function

● Examples of Setting

TEMP SP : 20°C

BAND : 2°C

READY TIME : 60sec.

“TEMP READY” is displayed on the operation display panel 60-sec. after TEMP PV value becomes 18°C to start output by communication.

Necessary condition is that TEMP PV value after 60-sec. is 20±2.0°C or less. See “5.3.4 Status screen 3” on page 5-1 for the details of display position.

● When the setting is OFF

BAND/READY function becomes invalid.

8.6 Anchor Bolt Mounting Position

8.6.1 Part 1

HRZ001-L	HRZ002-L	HRZ004-L	
HRZ001-L1	HRZ002-L1	HRZ004-L1	
HRZ001-L2	HRZ002-L2	HRZ004-L2	HRZ008-L2
HRZ001-H	HRZ002-H	HRZ004-H	HRZ008-H
HRZ001-H1	HRZ002-H1	HRZ004-H1	HRZ008-H1
HRZ002-W	HRZ008-W	HRZ002-W1	HRZ008-W1
	HRZ010-WS	HRZ010-W1S	HRZ010-W2S

Lock the brakes on casters (2 pcs. on the front), and attach the anti-seismic bracket (optional: HRZ-TK002) to secure this system.

⚠ CAUTION



- Anti-seismic bracket is an optional accessory, which is required for the installation of this system (HRZ-TK002).
- It is your responsibility to prepare anchor bolts suitable for your floor material.
M12-anchor bolts (4 pcs.) are required.

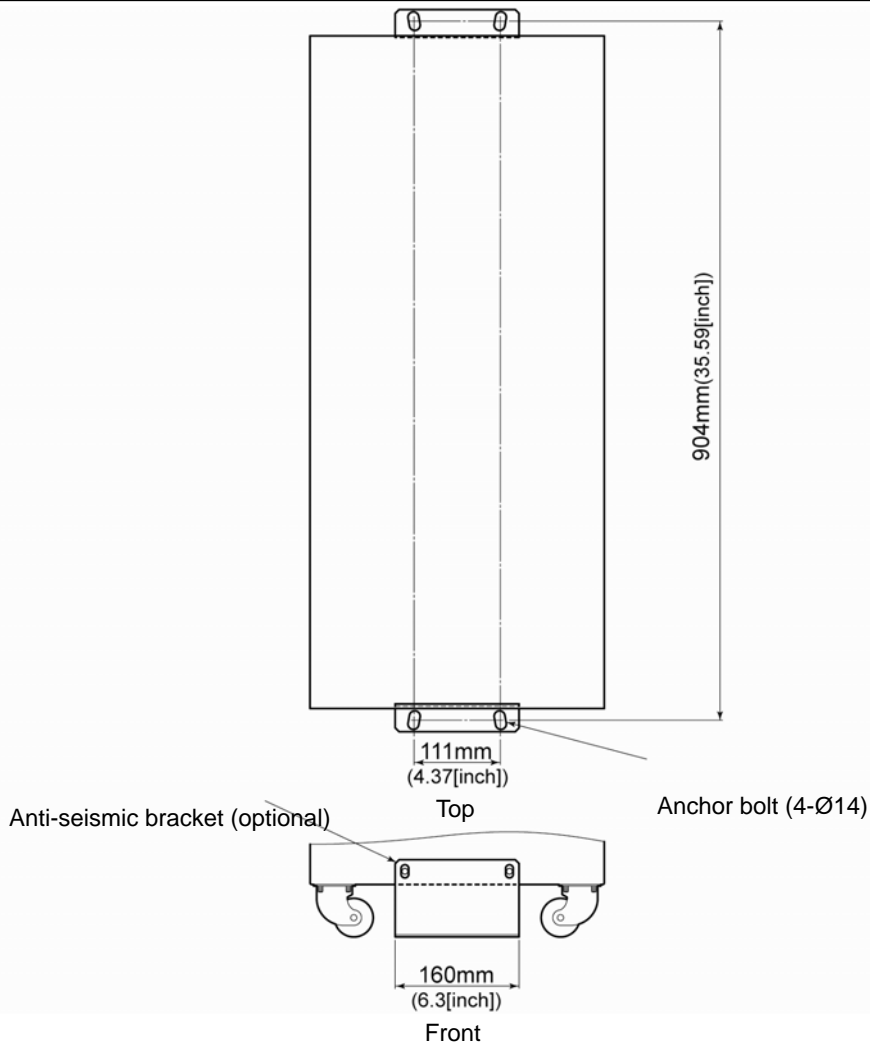



Figure 8-11 Anchor Bolt Mounting Position

8.6.2 Part 2

HRZ008-L HRZ008-L1

Adjust and secure the adjuster foot of this system to secure the anti-seismic bracket.

⚠ CAUTION



- Anti-seismic bracket is an accessory, which is required for the installation of this system.
- It is your responsibility to prepare anchor bolts suitable for your floor material. M8-anchor bolts (8 pcs.) are required.

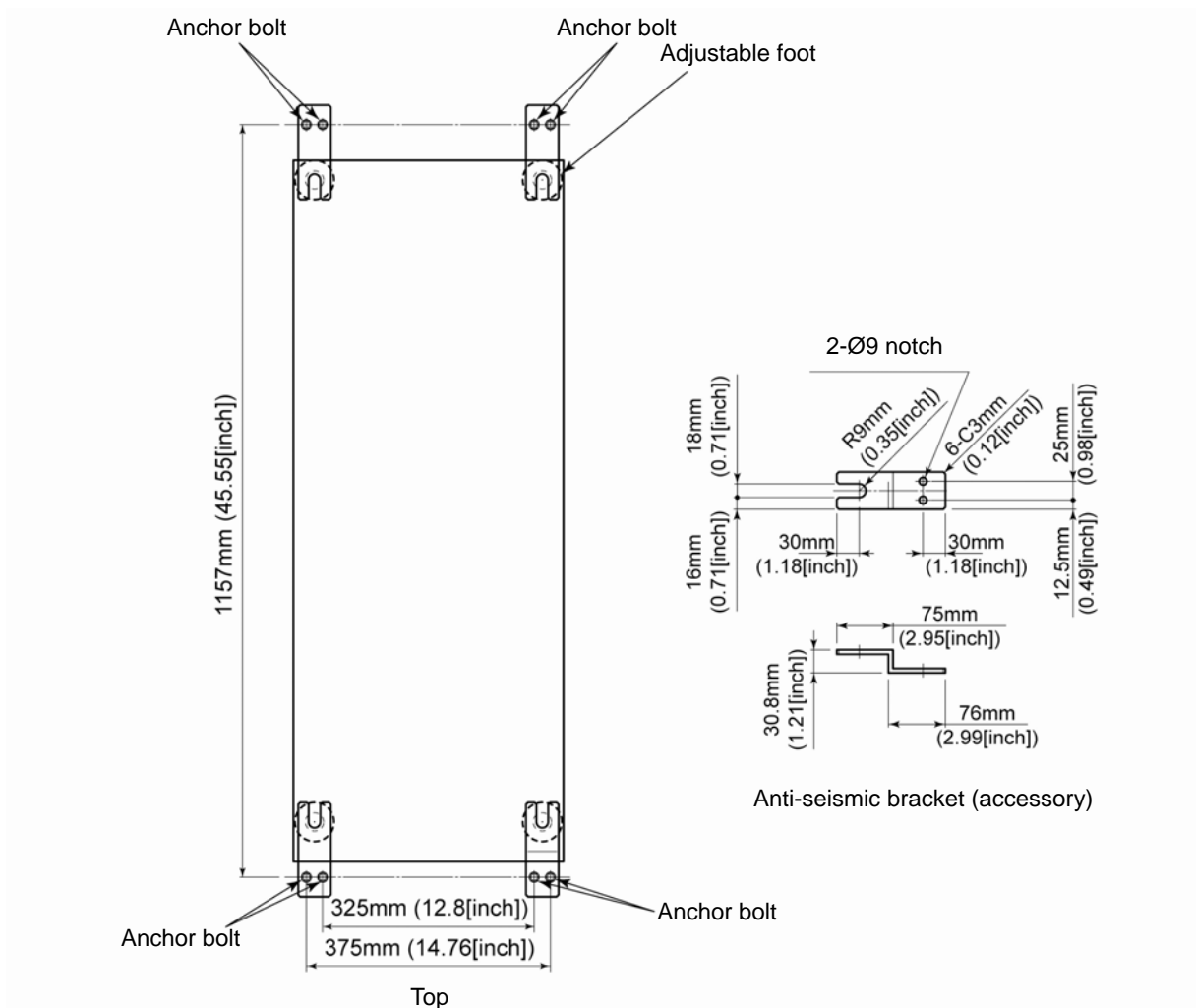

Figure 8-12 Anchor Bolt Mounting Position

8.7 Compliance

This system conforms to the following standards.

Table 8-14 Compliance

CE Marking	EMC Directive	2004/108/EC
	Low Voltage Directive	2006/95/EC
	Machinery Directive	2006/42/EC
SEMATECH	S2-93, S8-95	
SEMI	S2-0703, S8-0701, F47-0200	
UL	E229305 / UL1995	

Product Warranty

1. Warranty

If a failure is observed in our Thermo Chiller, repair shall be provided in accordance with the warranty period and preconditions defined below at SMC's option.

Repair involves the inspection and/or replacement and/or modification of a defective part.
Removed parts shall become the possession of SMC.

2. Warranty period

The warranty period of the product is 1 year in service or 1.5 years after the product is delivered.

3. Warranty exemption

SMC's liability under this warranty shall not be available for the following troubles and damages.

- (1) Troubles or damage caused by the neglect of our designated inspection (daily inspection, periodic inspection)
- (2) Troubles or damages caused by mishandling such as using improper operating procedure and using with our specifications violated
- (3) Troubles or damages caused by unauthorized modification.
- (4) Troubles or damages caused by the use of a not-designated circulating fluid and facility water
- (5) Troubles or damages caused by wearing out such as fading on the coated or plated surface
- (6) Sensory phenomena that are considered no effect on the functions (such as noise, vibration)
- (7) Troubles or damages caused by natural disaster such as earthquake, typhoon, water, inevitable events and fire
- (8) Troubles or damages occurred under the installation conditions defined in the Operation Manual
- (9) Troubles or damages that are not compliant with the "5. Warranty preconditions"

4. Escape clause

- (1) Expenses of daily inspection and periodic inspection
- (2) Expenses of repair consigned with neither SMC nor our authorized service station
- (3) Expenses of transport, installation, and removal of this system
- (4) Expenses of removal of non-genuine parts and replenishment of non-genuine fluids
- (5) Unavailability and loss due to this system being disabled
(such as telephone bill, leave compensation, commercial loss)
- (6) Expenses and compensation for terms other than provided in "1. Warranty"

5. Warranty precondition

Proper use and inspection of this system is required to assure safe use of this system. System warranty shall satisfy the following preconditions. Please take note that warranted repair shall not be available if these preconditions are disregarded.

- (1) System operation shall be conducted by following operating procedure defined in the Operation Manual.
- (2) Daily and periodic inspections designated in the Operation Manual shall be made as scheduled.
- (3) Inspection record shall be entered in the Daily Inspection Sheet provided in the Operation Manual.

6. Request for warranted repair

As to warranted repair, please contact the supplier you purchased this system from for service.
Warranted repair shall be on request basis.

Unrequited repair shall be provided in accordance with the warranty period, preconditions and terms defined above.
Therefore, the repair service shall be available on a chargeable basis if a failure is detected after the warranty period.