



Operation Manual

PRODUCT NAME

Refrigerated Air Dryer

MODEL / Series

IDU22E-30

IDU37E-30

IDU55E-30

IDU75E-30

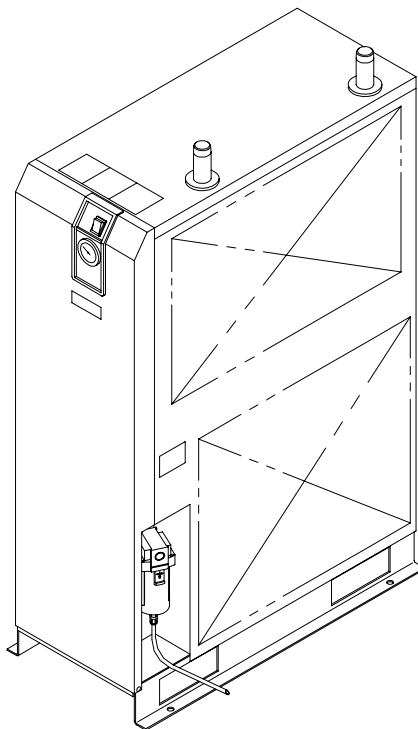

Please read this manual prior of using the air dryer. Keep the manual readily available for reference.

To Customers

Thanks for purchasing SMC Refrigerated Air Dryer.

This operation manual must be read and understood throughoutly before handling. It provides all essential information for maximizing product operating efficiency, as well as, for safe and longer life span operation.

For safety operation of SMC Refrigerated Air Dryer, read thoroughly and follow stated safety instructions, as well as regulation stated within ISO 4414^{*1} & JIS B 8370^{*2}.

*1) ISO 4414: Pneumatic fluid power – Recommendations for the application of equipment to transmission and control systems.

*2) JIS B 8370: Pneumatic fluid power – General rules relating to systems

This manual explains about installation and operation of the product. Only those who have thorough understanding of the fundamental operating procedure or have basic knowledge and skills of handling industrial product for the installation and operation of the product are qualified to perform installation and operation.

The contents of the operation manual and the other documents attached to the product cannot become a part of the contract clause or cannot change and modify existing agreements, promises, and relationship.

Any statements contained in the operation manual cannot be newly guaranteed and modify existing guarantee certificate.

You are not allowed to copy any part of this operation manual for usage of third person without informing it to us beforehand.

<p>Caution: Please understand that the contents of this operation manual are subject to changed without previous notice.</p>
--



Table of Contents

To Customers

Chapter i Safety Instructions

i - 1	Warning: Before Using Air Dryer	i - 1
i - 1 - 1	Meanings of signs: Caution, Warning, Danger	i - 1
i - 2	Danger Classifications / Position of Danger warning label	i - 3
i - 2 - 1	Danger Classifications	i - 3
i - 2 - 2	Danger of Electricity	i - 4
i - 2 - 3	Danger of high Heat	i - 4
i - 2 - 4	Danger of Rotor	i - 4
i - 2 - 5	Danger of Compressed Air Circuit	i - 4
i - 2 - 6	Positions of Danger Warning Label	i - 5
i - 2 - 7	Danger of Refrigerant	i - 6
i - 2 - 8	Cautions about Usage	i - 7
i - 2 - 9	Other Label	i - 7
i - 3	Disposal	i - 8
i - 4	Limited warranty and Disclaimer / Compliance Requirements	i - 9

Chapter 1 Parts Name and Functions

1 - 1	Parts Names and Functions	1 - 1
--------------	--	-------

Chapter 2 Transportation / Installation

2 - 1	Transportation	2 - 1
2 - 2	Installation	2 - 2
2 - 2 - 1	Location	2 - 2
2 - 2 - 2	Anchorage	2 - 2
2 - 2 - 3	Air piping	2 - 2
2 - 2 - 4	Drain Tube	2 - 3
2 - 2 - 5	Electric wiring	2 - 3
2 - 3	Cautions about reinstallation	2 - 4

Chapter 3 Operation / Shutdown

3 - 1	Check points before operation	3 - 1
3 - 2	Operation	3 - 1
3 - 3	Shutdown	3 - 2
3 - 4	Cautions about restart	3 - 2
3 - 5	Check points before restart	3 - 2
3 - 6	Precautions for long-term non-operation	3 - 2

Chapter 4 Maintenance

4 - 1	Daily inspection	4 - 1
4 - 2	Periodical maintenance	4 - 1
4 - 2 - 1	Cleaning of ventilation grille (suction grille)	4 - 1
4 - 2 - 2	Service parts	4 - 1
4 - 2 - 3	Cleaning of the case assembly	4 - 1

Chapter 5 Troubleshooting

5 - 1	Cause and countermeasure of errors	5 - 1
5 - 2	How to reset the thermal relay and high pressure switch	5 - 3

Chapter 6. References

6 - 1	Specifications	6 - 1
6 - 2	Dimensions	6 - 2
6 - 3	Electrical Circuit	6 - 3
6 - 4	Compressed Air and Refrigerant Circuit / Operation Principles	6 - 4



Safety Instructions



Before use, read and comprehend important cautionary notification well on this operation manual.

i – 1 Warning: Before Using Air Dryer

In this chapter, the stated contents are especially about safety way to use the product. for customer.

An Air Dryer is installed on the downstream of the air compressor to remove moisture. We, manufacturer, cannot take any responsibility if you use it for any other purpose.

An Air Dryer works with high voltage and has some parts that gets hot or rotates during operation. Ask vendor if you need component replacement and servicing.

Not only people handle the air dryer but every people who perform maintenance on or do works related to it should read safety instructions on this operation manual before handling.

This operation manual is not a general safety manual which is practiced by safety training representatives. People who handle this product or work around it need to take training to comprehend inherent risks of it and master measures for safety.

It is usually responsible for super visor to follow the safety instructions, but each operator or maintenance representative should do daily operations on their own head.

Operators and maintenance representatives should take the safety of working place and work environment into account.

It is necessary to think of the safety of working place and work environment for each task

Take enough safety training before the operation training. It is very dangerous to do operation training without any safety training. Operation training must be paid attention to its safety.

Reset the protective circuit referring to “5-2 How to reset the thermal relay”.

i – 1 – 1 Meaning of Signs: Caution, Warning, Danger

These safety instructions are intended to prevent hazardous situation and/or product damage.

These instructions indicate the level of potential hazard by signs “**Caution**”, “**Warning**” or “**Danger**”. Contents with these signs state about important instructions concerning safety. Confirm where those signs are, and read and comprehend notices and cautionary notices well before handling.

“**Caution**”, “**Warning**” or “**Danger**” is the order of importance (Danger>Warning>Caution).

Followings are the meanings of those signs.



Danger

Statements with the “Danger” sign explain about conditions in which there is a possible result of serious injury or loss of life if someone handles wrongly during operation or maintenance and did not follow the procedure to avoid danger.



Warning

Statements with the “Danger” sign explain about possibilities that can result in serious injury or loss of life if someone handle wrongly during operation or maintenance and did not follow the procedure to avoid danger.





Caution

Statements with the “Danger” sign explain about possibilities that can result in injury or product damage if someone handles wrongly during operation or maintenance and did not follow the procedure to avoid danger.

i – 2 **Danger Classifications / Position of Danger Warning Label**

To protect operator's safety, we group danger into some types uniquely and attached labels indicating those types. Confirm the contents of the danger types and positions of the labels before operation.

	Warning
<p>No one but professionals should operate an air dryer.</p> <p>Transportation, installation, and maintenance involve risks. These should be done by someone who have enough knowledge and experience about this product and incidental devices.</p> <p>No one but our service personnel or qualified person should open the cover panel of this product.</p>	

	Warning
<p>Should any problem occur, address it according to statements on this manual.</p> <ul style="list-style-type: none"> • Identify problems according to “Chapter 5 Troubleshooting.” • Ask repair and maintenance. 	

	Warning
<p>The product should not be operated in the event of any problems.</p> <p>When the product gets out of order, shutdown it immediatery, and contact our service person or qualified person.</p>	

i – 2 – 2 Danger Classifications

Specific danger classification of this product is as follows.

Danger of Electricity

Since this product runs at high voltage, there is the danger of electric shock. So, we display a symbol with indications, “**Caution**”, “**Warning**” or “**Danger**,” on the product and this manual.



Danger of Heat

Since this product becomes hot while driving, there is the danger of burn injury. So, we display a symbol with indications, “**Caution**”, “**Warning**” or “**Danger**,” on the product and this manual.



Danger of Rotor

Since this product has parts that rotate while driving, there is the danger of catching your fingers in or injury. So, we display a symbol with indications, “**Caution**”, “**Warning**” or “**Danger**,” on the product and this manual.



i – 2 – 2 Danger of Electricity 

Inside of this product, there is power-supplying section with high voltage separated by the cover panel. Do not operate the product without the cover panel.

No one but trained qualified person should operate or inspect in the power transmission sections.

**Warning**

Read with caution and pay attention to the notations on danger warning labels.

Do not remove or rub danger warning labels.

Confirm the positions of danger warning labels.

i – 2 – 3 Danger of High Heat **Warning**

Since this equipment has parts that become hot during operation, there is the danger of burn injury resulting from contact with them. What is more, there is also the danger of burn injury due to remaining heat after the power supply is cut. Therefore, wait until the temperature of hot parts become 50°C and below.

i – 2 – 4 Danger of Rotor **Warning**

Since this product has parts that rotate during operation, there is the danger of burn injury resulting from contact with them. Though sometimes those parts can temporarily stop the rotation, they will rotate again, and so do not work with them while driving.

i – 2 – 5 Danger of Compressed Air Circuit **Warning**

Before replacing or cleaning parts, be sure to bleed compressed air remain inside of the product until the gauge indicates “0”. If you do not do this air-bleeding, there would be the great danger of unexpected accident, such as shooting out of parts when they are being unscrewed.

i - 2 - 6 Positions of Danger Warning Label

 Warning
<p>Read with caution and pay attention to the notations of danger warning labels.</p> <p>Do not remove or rub danger warning labels.</p> <p>Confirm the positions of danger warning labels.</p>

 **WARNING 警告**

- 1 Remove panels for maintenance only.
- 2 Never insert anything into product to ensure safety.
- 3 Cut power prior to maintenance to prevent electric shock.
- 4 Settle product to room temp. before maintenance to prevent burn or frostbite.
- 5 Ensure zero air pressure before replacing parts.

- 1 点検以外はパネルを取り外さないこと。
- 2 回転物があるので指、棒状の物を差し込まないこと。
- 3 感電の恐れがあるので、点検の前には電源を切ること。
- 4 火傷の恐れがあるので、点検の前には装置を常温にすること。
- 5 部品交換の前には必ず、空気圧力を“0”にすること。

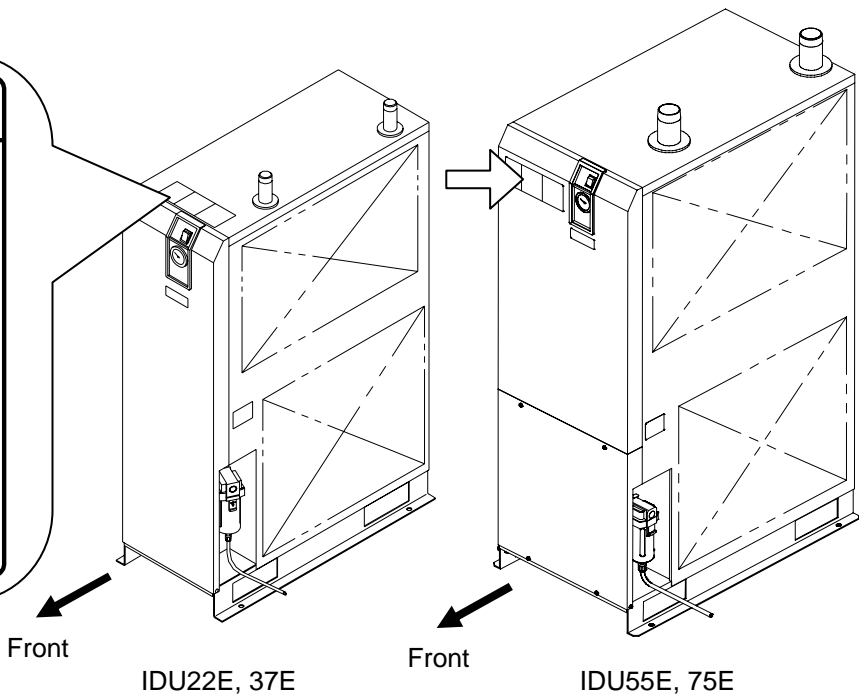

i - 2 - 7 Danger of Refrigerant

**Caution**

This product uses Fluorocarbon (HFC) as a refrigerant.

This product is specified by “Class 1 Fluorocarbon Collection and Destruction Law in Japan.” It is strictly forbidden to emit Fluorocarbon to the atmosphere. Before you repair this product, you should collect the refrigerant with “Refrigerant collector.” Then, ask a destruction agency to dispose of collected refrigerant. No one but someone have enough knowledge and experience about the product and incidental device should do the collection of the refrigerant. No one but service person or qualified person should remove the cover panel of the product.

The quantity and the sort of the Fluorocarbon are mentioned on the specification label that are explained on Page i - 7.

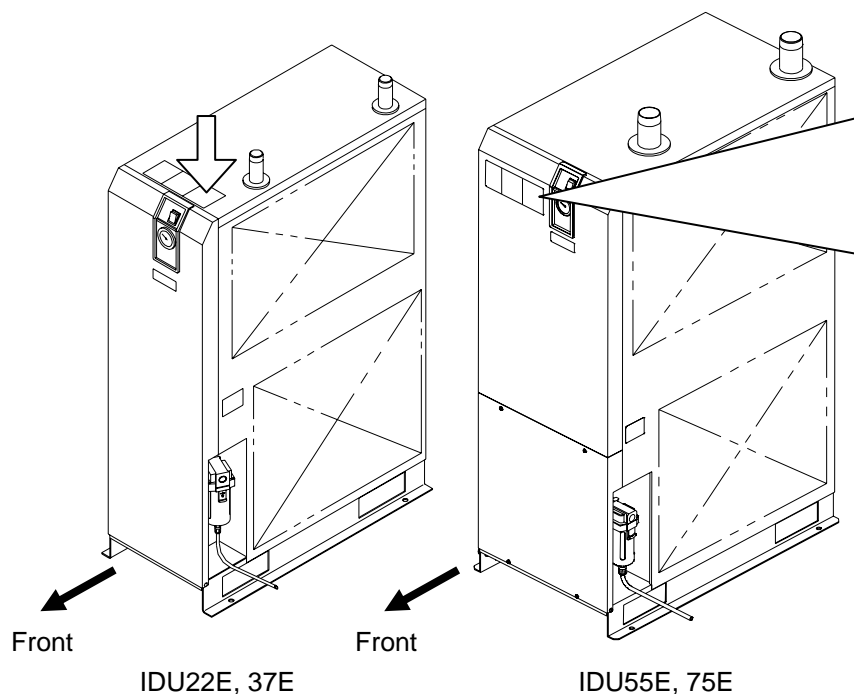

Fluorocarbon Collection and Destruction Law in Japan
フロン回収破壊法第一種特定製品

This product uses
Fluorocarbon (HFC) as a refrigerant.

- 1 It is strictly forbidden to emit Fluorocarbon to the atmosphere.
- 2 When disposing this product, Fluorocarbon must be collected in an appropriate manner.
- 3 The kind of Fluorocarbon and the amount used in this product is printed on the name label.

この製品には冷媒として、
フロン類(HFC)が使われています。

- 1 フロン類をみだりに大気中に放出することは禁じられています。
- 2 この製品を廃棄する場合には、フロン類の回収が必要です。
- 3 フロン類の種類及び数量は、型式銘板に記載されています。

i - 2 - 8 Cautions about Usage

Warning

Read with caution and pay attention to the notations on danger warning labels.
 Do not remove or rub danger warning labels.
 Confirm the positions of danger warning labels.

CAUTION 注意

- 1 Read manual before operation.
- 2 Ensure ventilation and maintenance space.
- 3 Keep water away from the product.
- 4 Secure In / Out connector with spanner during piping.
- 5 Wait 3 minutes before restart.
- 6 Ensure Running Condition / Evaporating Temp. in green zone.

- 1 ご使用前に必ず取扱説明書を読んでください。
- 2 通風、メンテナンススペースを確保してください。
- 3 雨や水滴がかからないようにしてください。
- 4 IN/OUTポートをスパナで固定して配管してください。
- 5 再起動は運転停止3分後に行ってください。
- 6 RUNNING CONDITION・蒸発温度計はグリーン帯で使用してください。

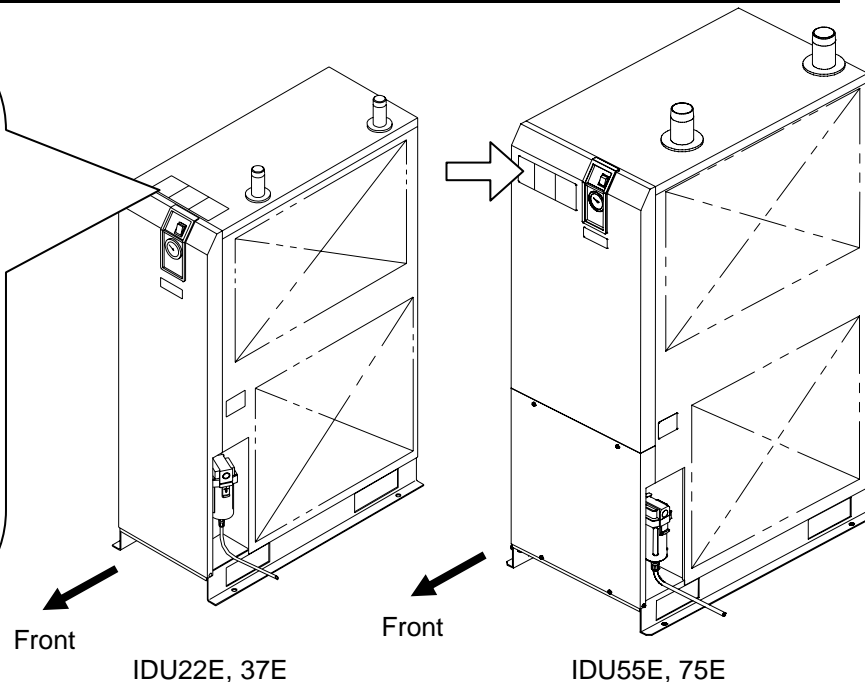

i - 2 - 9 Other Label

Confirm the model, contents of specifications on the label.

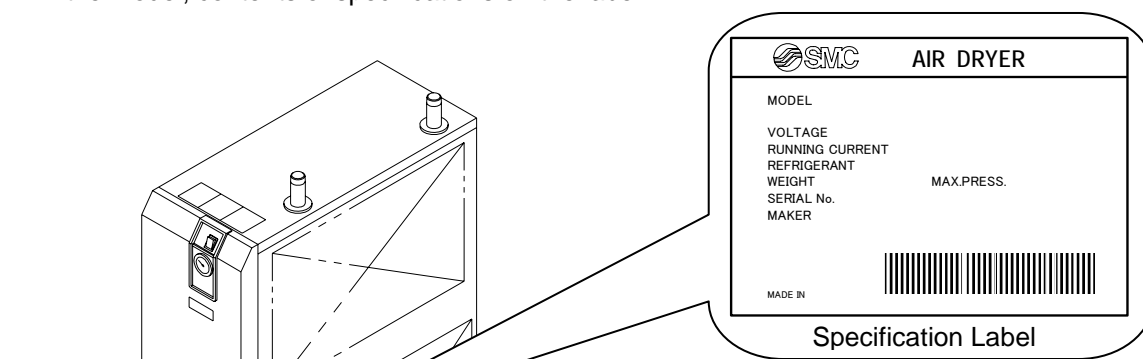

Contents

MODEL: Model
 VOLTAGE: Power supply voltage (frequency)
 RUNNING CURRENT: Running current
 REFRIGERANT: Type of refrigerant (amount)
 WEIGHT: Weight MAX.PRESS: Maximum operating pressure
 SERIAL No.: Serial No.
 MANUFACTURING DATE: Manufacturing Date
 MADE IN: Country of manufacture

i – 3 Disposal

When you dispose of the product, you should collect the refrigerant and the refrigerant oil enclosed in the refrigerant circuit.



Caution

A sort of Fluorocarbon (HFC) is used for this product as refrigerant.

This product is specified by “Class1 Fluorocarbon Collection Destruction Law in Japan.” It is strictly forbidden by the law to emit the refrigerant to the atmosphere. Before you repair this product, you should collect the refrigerant with “Refrigerant collector.” Then, ask a destruction agency to dispose of collected refrigerant.

No one but someone who has enough knowledge and experience about the product and incidental devices should do the collection of the refrigerant.

No one but a service person or qualified person should remove the cover panel of the product.

The quantity and the sort of the Fluorocarbon are printed on the specification label.



Caution

Dispose of the refrigerant and refrigerant oil according to the bylaw or regulation of local government.

Do not dispose of refrigerant oil together with domestic garbage. And do not burn it in unauthorized incinerators.

No one but someone who has enough knowledge and experience about the product and incidental devices should do the collection of the refrigerant oil.

No one but a service person or qualified person should remove the cover panel of the product.

If there is something not clear, please contact our service office.

i – 4 Limited warranty and Disclaimer / Compliance Requirements

The product used subject to the following “Limited warranty and Disclaimer“ and “Compliance Requirements. Read and accept them before using the product.

Limited warranty and Disclaimer

1. The warranty period of the product is 1 year in service or 1.5 years after the product is delivered. Also, the product may have specified durability, running distance or replacement parts. Please consult your nearest sales branch.
2. For any failure or damage reported within the warranty period which is clearly our responsibility, a replacement product or necessary parts will be provided.
This limited warranty applies only to our product independently, and not to any other damage incurred due to the failure of the product.
3. Prior to using SMC products, please read and understand the warranty terms and disclaimers noted in the specified catalog for the particular products.

Compliance Requirements

1. The use of SMC products with production equipment for the manufacture of weapons of mass destruction (WMD) or other weapon is strictly prohibited.
2. The exports of SMC products or technology from one country to another are governed by the relevant security laws and regulation of the countries involved in the transaction. Prior to the shipment of a SMC product of a SMC product to another country, assure that all local rules governing that export are known and followed.

Caution

**The Product is provided use in manufacturing industries.
The product herein described is basically provided for peaceful use in manufacturing industries.
If considering using the product in other industries, consult SMC beforehand and exchange specifications or a contact if necessary.
If anything is unclear, contact your nearest sales branch.**

1 Parts Name and Functions

1 - 1 Parts Name and Functions

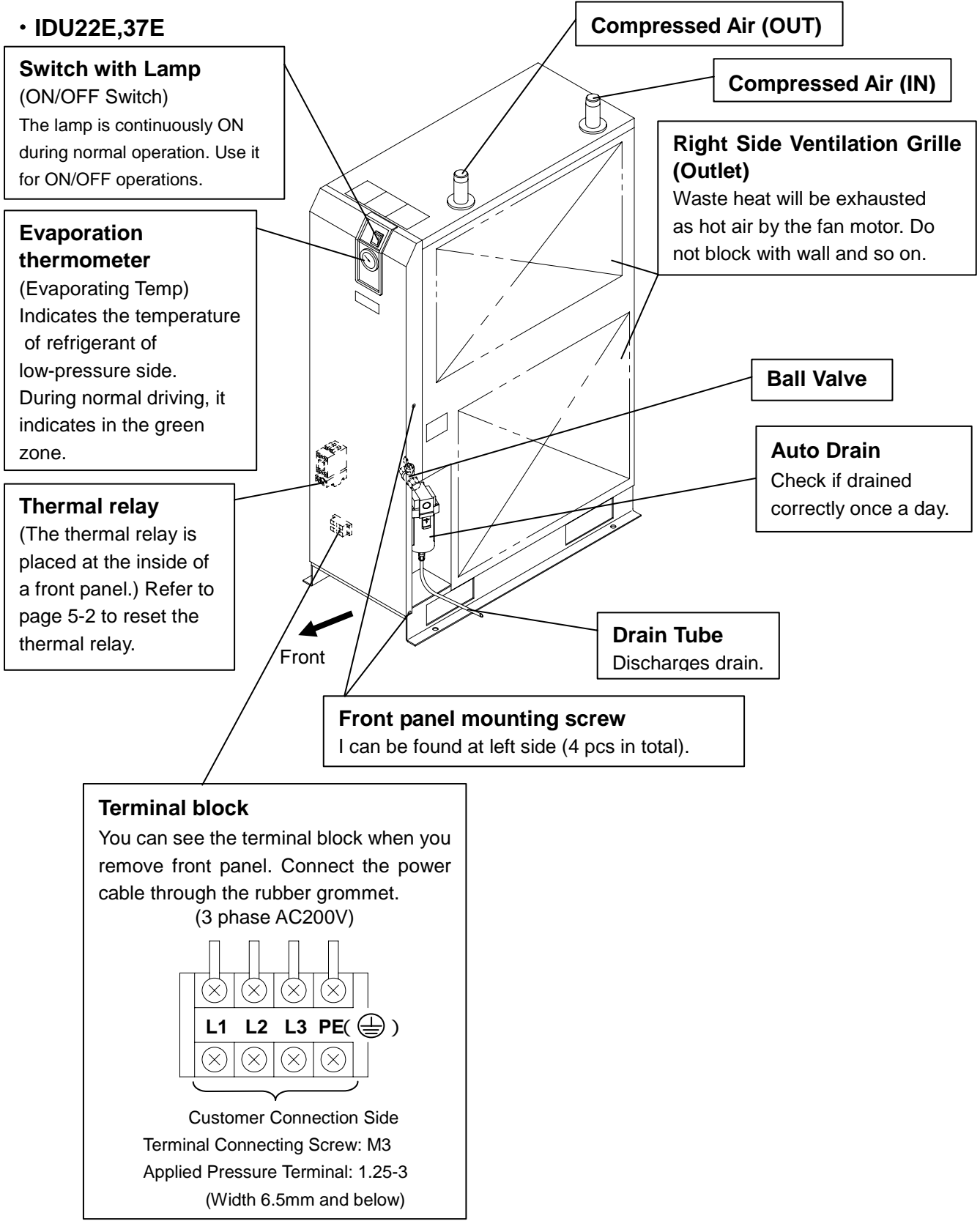

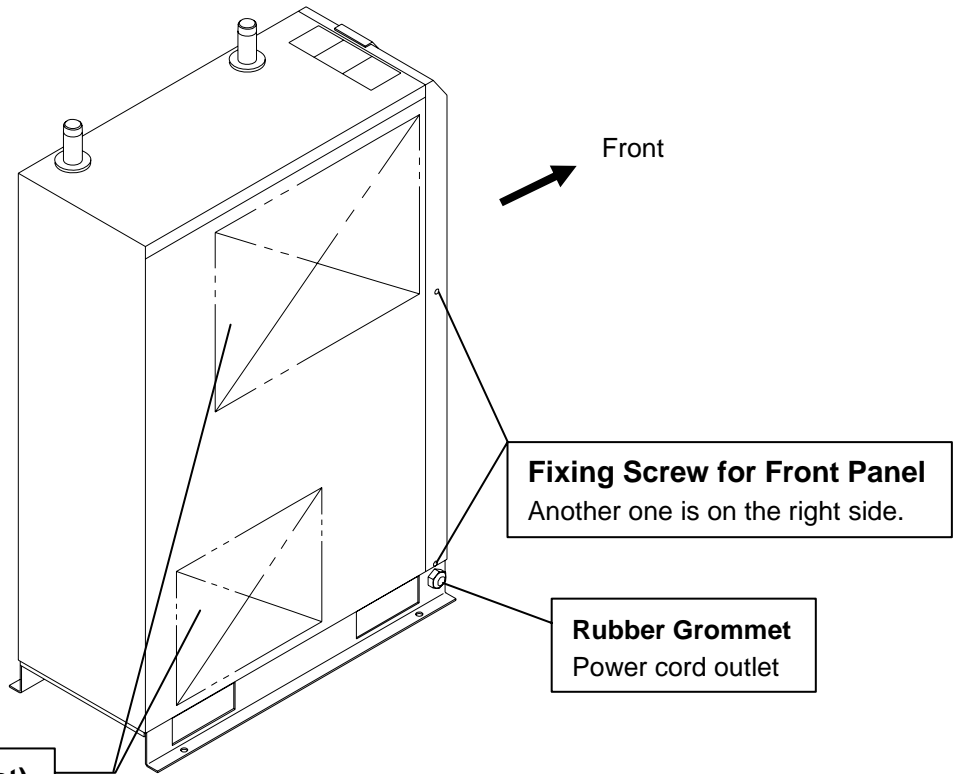

Left Side Ventilation Grille (Inlet)
Breathe in cooling air from this grill.
Do not bung up with wall and so on.

Fixing Screw for Front Panel
Another one is on the right side.

Rubber Grommet
Power cord outlet

• IDU55E,75E

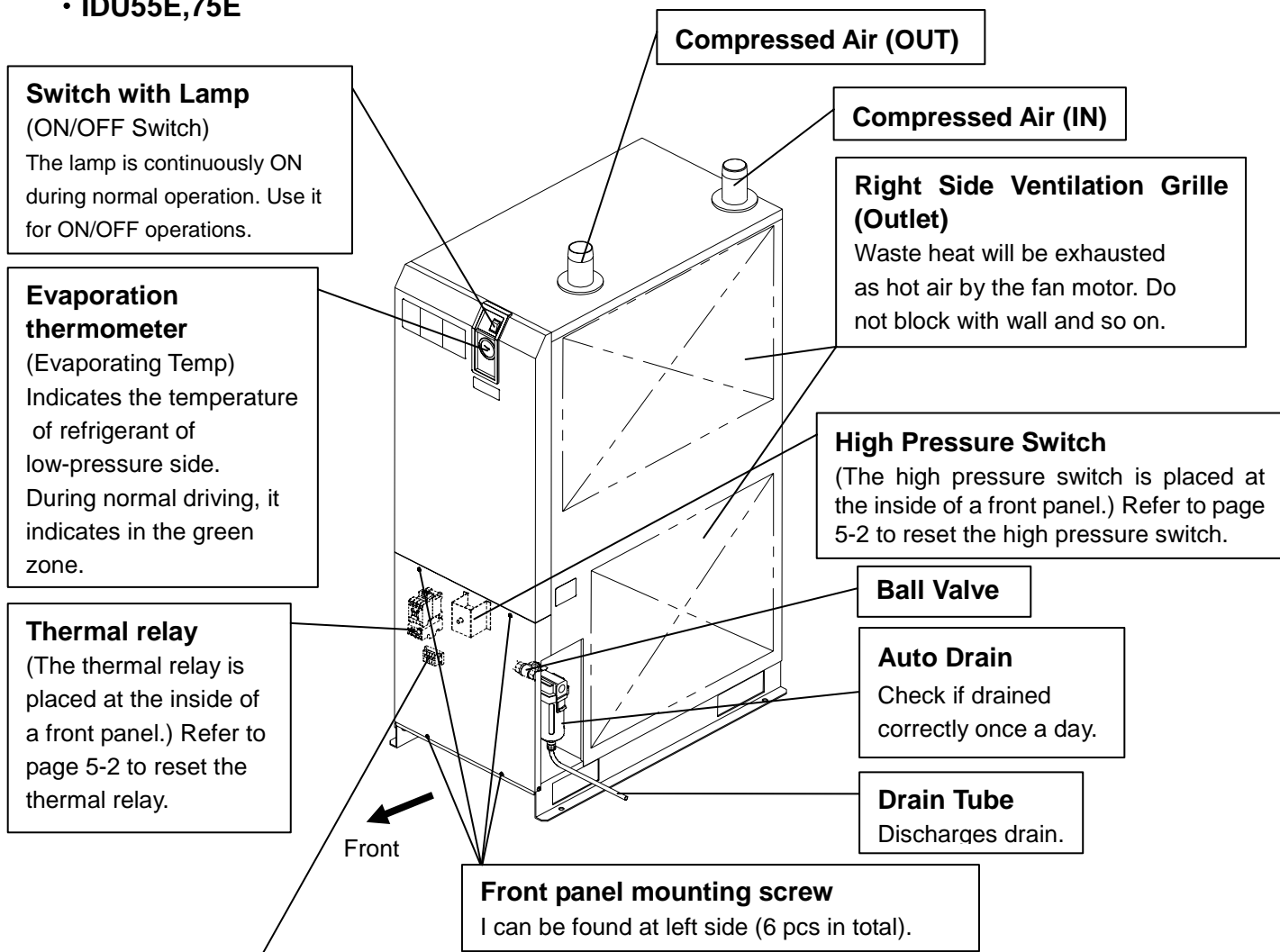

Terminal block

You can see the terminal block when you remove front panel. Connect the power cable through the rubber grommet.
(3 phase AC200V)

Customer Connection Side
Terminal Connecting Screw: M3
Applied Pressure Terminal: 1.25-3
(Width 6.5mm and below)

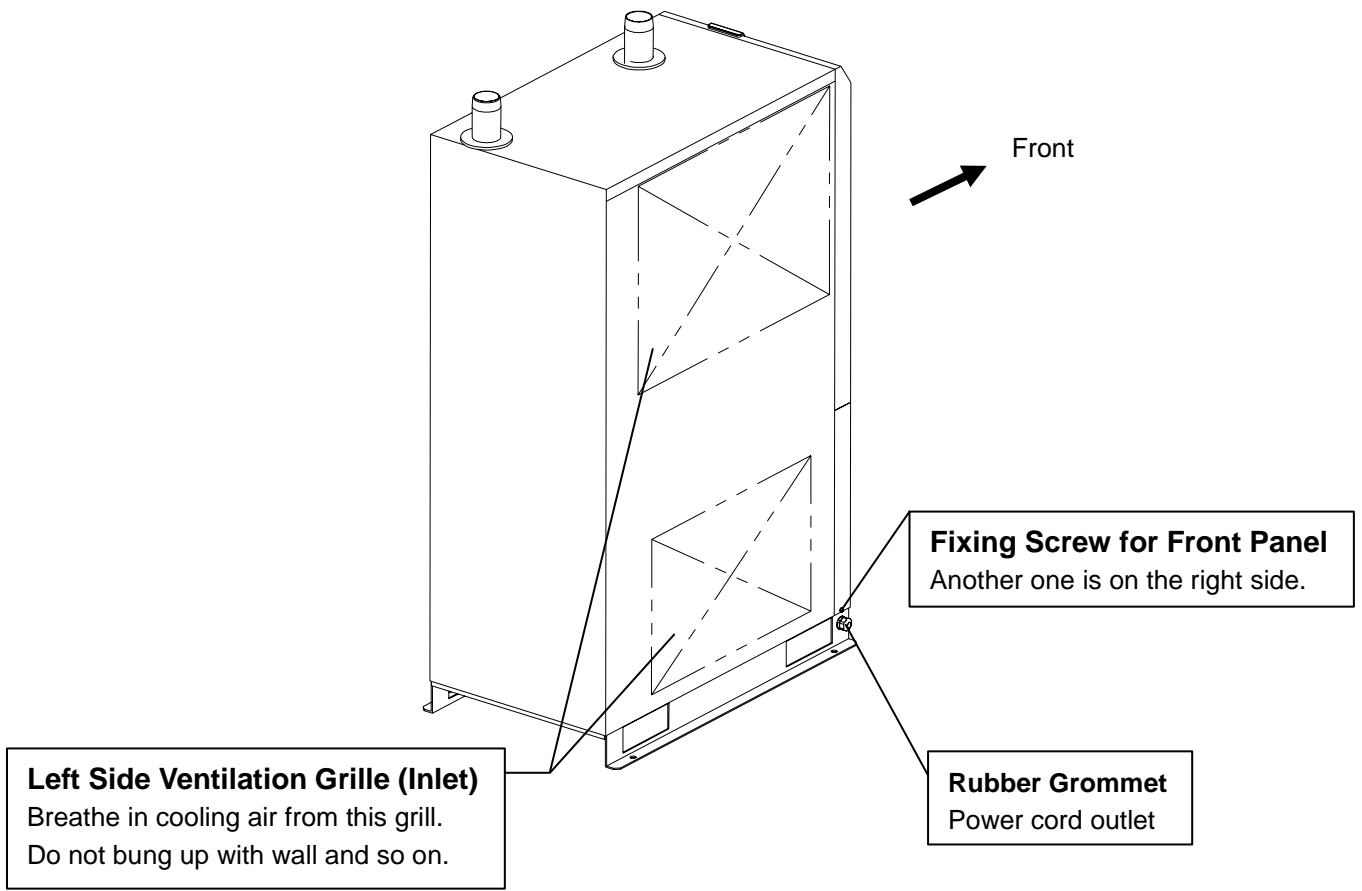



Transportation / Installation



Warning

Use the product in the right way. During Installation, operation, maintenance, and check, you should be careful in keeping the safety of human body.



Caution

Transportation, installation, and maintenance including dangerous work must be done by a personnel who has enough knowledge and experience about the product and the system.

2 - 1 Transportation

When you transport the product, you should follow these instructions below.

- You should uplift the product from the base surface with careful attention to prevent falling sideways and drop.
- Do not bring the product lying sideways. If you lay it sideways, it will be broken.
- Do not hang up the product.
- Do not transport the product with any part such as an air filter mounted on the fittings at the air inlet or outlet port of the product. If it is unavoidable to transport the product with such a part mounted, support the mounted part with a bracket to prevent the product from being affected by vibration during transportation



Warning

Those instructions above must be followed because the product is so heavy that it carries a great risk to transport.

IDU22~75E are 90~170kg or more. They must be transported by forklift of IDU22E~IDU75E.

2 - 2 Installation

2-2-1 Location

The product should not be used or stored in the circumstances as follows.

Those circumstances will cause not only malfunction but also failures.

- Environment where the product is exposed to rainwater, moisture vapor, salty water, oil and so on.
- Locations where dust or particles are.
- Locations where inflammable or explosive gas are.
- Locations where corrosive gas, solvent, combustible gas are.
- Locations that receive direct sunlight or where radiant heat is generated.
- Locations where ambient temperature is beyond following range:
 On-stream: 2 ~ 40°C
 Storage: 0 ~ 50°C (when there is no drain water inside of the piping)
- Locations where temperature changes rapidly.
- Locations where strong electromagnetic noise is generated (locations where electromagnetic field, strong magnetic field, surge is generated)
- Circumstances where static electricity is produced or discharged through the body of the product.
- Locations where strong high frequency wave is generated.
- Locations where danger of thunder is apparent.
- Locations by loading on vehicles, marine vessels, and so on.
- Locations whose altitude is higher than 2,000 meters.
- Circumstances where strong vibration or impact are transmitted.
- Circumstances where too much force and weight are put on the body of the product that causes it to deform.
- Circumstances where enough spaces cannot be taken to do maintenance (in the plant where the product is operated).
 Spaces needed for maintenance
 Front : 600 mm
 Rear : 600 mm
 Top : 600 mm
 Right : 600 mm
 Left : 600 mm
- Locations the ventilation grille of the product can be blocked.
- Place where rejection style air of air compressor or other driers (hot wind) is inhaled.

 **Warning**

Do not use and store in environment having compressed air or ambient atmosphere which includes the following substances. It could result in failure of the product and damage of components, which leads to injury.

- Corrosive gas, Organic solvent, Chemicals

2-2-2 Anchorage

- The air dryer should be installed on a vibration-free, stable, horizontal flat surface.
- Refer to "Chapter6 6-2 Dimensions" for the dimensions.
- Fix by bolts to prevent falling down. The bolts can be prepared separately as an accessory.

Model No.	Name	Quantity	Applicable Model
IDF-AB501	Anchor bolt set	1 (4 pcs / 1 set)	IDU22E, IDU37E, IDU55E, IDU75E

2-2-3 Air piping

- Connection to the inlet and outlet of compressed air should be made removable by using union and so on.
- Pressing the hexagonal fitting with screw wrench and so on, connect the air piping fittings to the body.
- When mounting any part such as an air filter on the fitting at the compressed air inlet or outlet port, support the part to prevent excessive force from being applied to the product.

- Be careful not to let the vibration of the air compressor transmit.
- If the temperature of compressed air on the inlet side is higher than 80°C, place an aftercooler after the air compressor. Or, make the temperature of the place where the air compressor is installed lower than 80°C.
- Flash the piping sufficiently in order to avoid any foreign substances such as dust, sealing tape, liquid gasket, etc. when piping before piping connection. Foreign substances in the piping can cause cooling failure or drainage failure.
- Use pipes and fittings that have enough endurance against the operating pressure and temperature. And connect it firmly to prevent air leakage.
- Provide bypass piping to make it possible to do maintenance without stopping the air compressor.

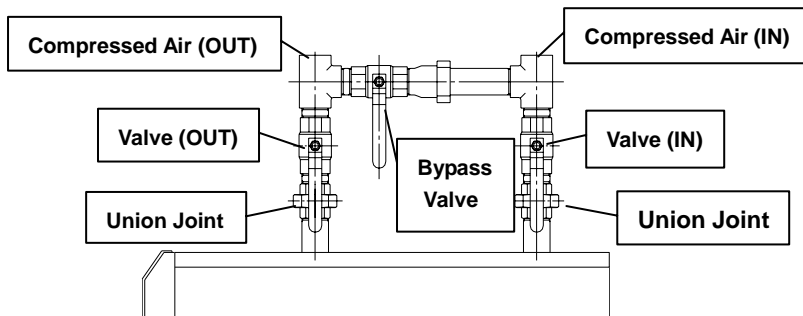

We recommend the bypass piping sets that we are selling separately as accessories.

Model No.	Name	Q.t	Applicable Model
IDU-BP336	Bypass piping sets	1	IDU22E
IDU-BP337		1	IDU37E
IDU-BP338		1	IDU55E
		1	IDU75E

2-2-4 Drain Tube

- A polyurethane tube of 10mm external diameter is attached to the drain tube. The outlet end of the tube is released to atmosphere. And let drain flow through the tube into a scupper and so on.
- Using the pressure of the compressed air, drain will be discharged periodically. Fix the outlet end of the tube so as not to swing during discharge.
- Prevent the drain tube from riser piping.
- Prevent the drain tube from being folded or flatted. Since the drain tube is coming from the bottom of the body, be careful to avoid the body from stomping over the tube during installation.

2-2-5 Electric Wiring



Warning

No one but qualified person should do the wiring work.

- **Before wiring, you must cut the power off for safety. Do not work under any energized conditions.**
- **Supply power from a stable place, which is free from the effect of surge. Ensure that an Ground Fault Circuit Interrupter(GFCI) with appropriate capacity for earth leakage and load is used in the power supply of the product to prevent electrical shock and burnout of the compressor motor. See “6-1 List of specifications” for details.**
- **Supply power for the product should meet the specifications.**
- **The product should be grounded for safety.**
- **Do not connect the earth to a water pipe, a gas pipe, or a lightning.**
- **Do not plug too many leads into a single socket. That causes exothermic heat or fire.**
- **Do not convert the wiring to use.**
- **In European countries, a circuit breaker that meets the IEC standard should be used for the supply power.**

How to connect wiring

- Take off the front panel in front of the product and connect the power supply (AC200V) to the terminal base.
- Install an Ground Fault Circuit Interrupter(GFCI) to the power supply (Prepare by yourself)
[Sensed current: 30mA and below, Rated current 10A (IDU75E...Rated current 15A)]

Specification of power cable

Prepare following power cable.

Power cable: 1.25mm²(16AWG), External diameter: about 8 ~ 12mm

IDU22E ~ 75E-30 (3 phase power supply) ...4 cores (including grounding)

Additional length of about 0.2m is needed to wire inside of the product.

Length of the power cable

The length of the power cable should extend less than 30m from the product.

Connecting to the power supply

Connect the power cable and the earth to the terminal block. M3 screw is used for the connection part. Make sure to use round crimped terminal.

Applicable crimped terminal: 1.25-3 (Width: 6.5mm and below)

Wiring procedure

- Remove the front panel.
- Insert the cord through the rubber grommet and connect it to the terminal block (refer to the label on the terminal block). M3 screw tightening torque: 0.6~1Nm
- During wiring work, do not touch other sections except terminal block.
- Attach the front panel as it were.

2 - 3 Cautions about Reinstallation**Caution**

No one but someone who has enough knowledge about the product and incidental devices should reinstall in another place. And following instructions must be executed.

If you move the product and reinstall it into another place after some operations (including trial running), instructions that are not only following ones but also all of those in the chapter 2 should be followed.

Disassembly of the power cable

Cut off the power source when you disassemble the power cable.

**Warning**

**No one but qualified personnel should do the electric wiring.
Cut off the power supply for safety before the wiring. Do not work under energized condition.**

Disassembly of the air piping**Warning**

**No one but qualified personnel should do the air piping.
Separate the compressor from the product for safety before removing the piping. Do not remove any piping when there is remaining compressed air pressure inside of it.**

- Remove the seal tape completely after detaching the piping. Remained tape will cause imperfect cooling and failure by entering into the body of the product.

Residual compressed air pressure release procedure

- Even while the dryer is removed, only when compressed air is needed, open the bypass piping valve.
- Close the compressed air inlet and outlet valve.
- Make sure the ball valve located next to the auto drain opened.
- Open the auto drain residual pressure release valve to release air pressure inside the product. Refer to the figure at right.

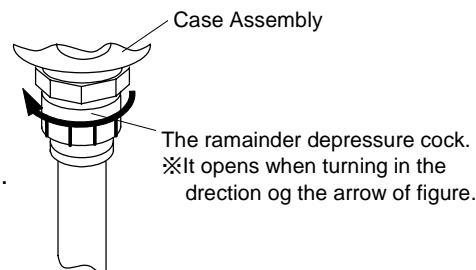



Operation / Shutdown



Caution

No one but someone who has enough knowledge and experience about the product and incidental devices should operate or shut down the product.

3 - 1 Check points before operation

Before a trial running, check following points.

- **Installed Condition**
By visual inspection check that the product is installed horizontally.
Make sure the product is fixed enough with anchor bolts.
Do not place heavy obstacles on the product and add unreasonable loading by piping and so on.
- **Wiring Connections**
Power cord, and the earth should be connected firmly.
- **Drain Tube**
Drain tube should be connected correctly.
- **Air Piping**
Make sure the piping for compressed air is connected correctly. Those valves of IN / OUT side and bypass piping of the product and of the bypass piping should be completely fasten.
- **Ball valve**
Make sure the ball valve located next to the auto drain opened.

3 - 2 Operation

Start operation according to the procedure below.

- Turn on the breaker of the main power supply. Then, turn on the Switch with Lamp.
- The lamp will light up. Few minutes later, the cooling fan will rotate and hot air will be exhausted from the ventilation grille.
Place of the ventilation grille: Right Side Ventilation Grille
- Open the IN / OUT side valve slowly. Make sure the bypass valve is completely closed. Make sure the bypass valve is completely closed. Confirm there is no air leakage.
- Depending on the condition of compressed air or ambient temperature, the cooling fan sometimes alternates between rotation and stop at the beginning. Then, the refrigerator will go into continuous run and the pointer of the evaporation thermometer will indicate in the green zone. If the pointer of the evaporation thermometer indicates higher than the green zone, refer to "Chapter5 Troubleshooting."
- After a while from the start of flowing the compressed air, drain will be discharged from the drain tube automatically.
- Keep the condition of continuous run to use.



Caution

Avoid frequent ON / OFF operation, which can cause troubles.

The auto drain used for the product has a structure that closes the valve with air pressure higher than 0.15MPa. Therefore, until the pressure increase, air will be emitted from the drain outlet at the beginning of opening the IN side valve. Keep in mind that sometime the pressure cannot increase enough with air compressor that has low discharge flow rate.

3 - 3 Shutdown

- Turn off the Switch with Lamp.
- The lamp will go out and then, the operation will be stopped. Depending on the condition of operation, hot air continues to be emitted from the ventilation grille by the cooling fan for a while after turning off the switch, which is not an abnormality but a process for safety shutdown.

3 - 4 Cautions about restart

- One must wait for at least 3 minutes before restarting air dryer after it has been shut down. Failure to do this may cause safety devices to trip due to over load.
If it is not possible to restart, refer to "Chapter 5 Troubleshooting."

3 - 5 Check points before restart

Check following points before you start operation. If any abnormalities occur, immediately stop the operation. Turn off the Switch with Lamp of the product and then the breaker to the power supply.

- There is no leakage of compressed air.
- Compressed air pressure, temperature, flow rate, and ambient temperature meet the specifications.
- Drain is being discharged from the drain tube.
- The pointer of evaporation thermometer is indicating in the green zone.
- There are no abnormal sound, vibration, or smelling.

3 - 6 Precautions for long-term-non-operation

- If the product will not be operated for 24 hours, for example at the weekend, turn off the RUN switch or power supply, for energy saving and safety. It is also recommended to release the pressure inside the compressed air piping.



Maintenance

4 - 1 Daily Inspection

Check following points during usual operations. If you find some problems, immediately stop the operation and refer to "Chapter 5 Troubleshooting" as soon as possible.

- There is no air leakage
- The running lamp is lighting during operation
- Drain is being discharged from drain tube
- The pointer of the evaporation thermometer indicates in the green zone when it is running with pressurized air supply.
- The pointer of the evaporated thermometer indicates about 3~10°C lower than that of ambient temperature when the product is suspended with no pressurized air supply.
- There is no abnormal sound or vibration coming up from the product.
- There are no abnormal smell or smoke coming up from the product.

4 - 2 Periodical Maintenance

4-2-1 **Cleaning of ventilation grille (suction grille)**

Clean dust and other foreign particles from the ventilation area with vacuum cleaner or air blow nozzle once a month.



Caution

During air blowing, put on protective glass and mask to prevent dusts from coming into throat or eyes.

4-2-2 **Service parts**

It is recommended to replace the following parts regularly. The interval values shown in this operation manual depend on the operating conditions (ambient temperature, installation environment, etc.), so that they are for reference.

- Table 1. List of parts to be replaced regularly

Description	Recommended replacement period *Note}
Pressure switch	One Million times.
Fan motor	20,000 hours
Magnetic Contactor, Magnetic Switch	One Million times.

*Note) If it is mounted by option "T" (With terminal block for power supply, run, alarm signal and remote operation) or special order.

4-2-3 **Cleaning of the case assembly**

Remove the dust deposited in the auto drain case assembly every month. Use neutral detergent for cleaning. If the degree of dirt is heavy and operating failure still continues even after cleaning, replace the product. Also, shorten cleaning interval from the next time.

- Part No. of case assembly

Part No.	Name	Quantity	Applicable Model
AD48	Case Assembly	1	IDU22E, IDU37E IDU55E, IDU75E



Warning

- Maintenance of the air dryer should only be carried out by someone with sufficient knowledge and experience of air dryers and related equipment.
- Before carrying out maintenance, the important warnings in this manual must be thoroughly read and understood.



Danger

- When replacing or cleaning parts of the air dryer, be sure to remove the compressed air pressure inside the air dryer to "0". Never remove the case assembly when the air dryer is operated or air pressure remains inside. It is extremely dangerous if compressed air pressure remains inside the air dryer, as parts may come flying off at speed when loosened, or other unexpected accidents.
- This product has parts that become hot during operation and a power supply with high voltage applied. There is a risk of burns due to heat or electrification by high voltage. Even when operation is shut down after switching off the air dryer's illuminated light, there are also charging lines. When working on the charged sections, be sure to switch off the earth leakage breaker installed before starting work.
- As some parts of the air dryer will remain hot, there is a risk of burns due to residual heat after the power is switched off. So do not carry out replacement work until the temperature of these parts has fallen to 50°C or less. Wait for about 10 to 15 minutes as a guide.
- When carrying out maintenance work on the auto drain strainer and auto drain, there is a risk of touching the drain fluid during work. Please follow the safety procedure for operators specified by customer. (Example: carry out work wearing safety glasses, apron and gloves to prevent discharged fluid from touching the human body.)
- Use neutral detergent solution to clean parts such as the auto drain strainer and auto drain. Never use solvent such as thinner.
- When removing the outer casing panel or case assembly of the auto drain, wear gloves to prevent injuries.

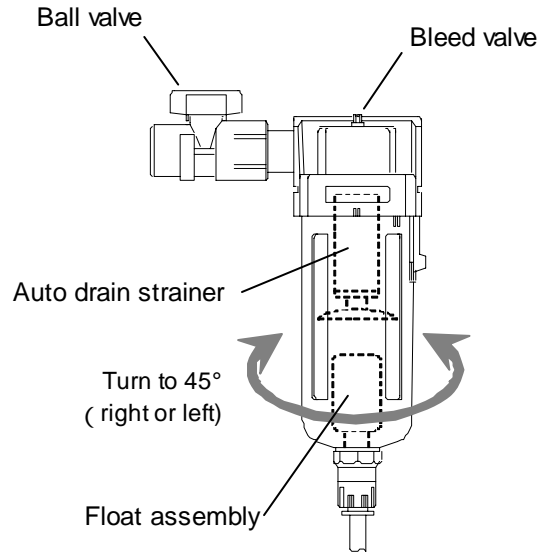
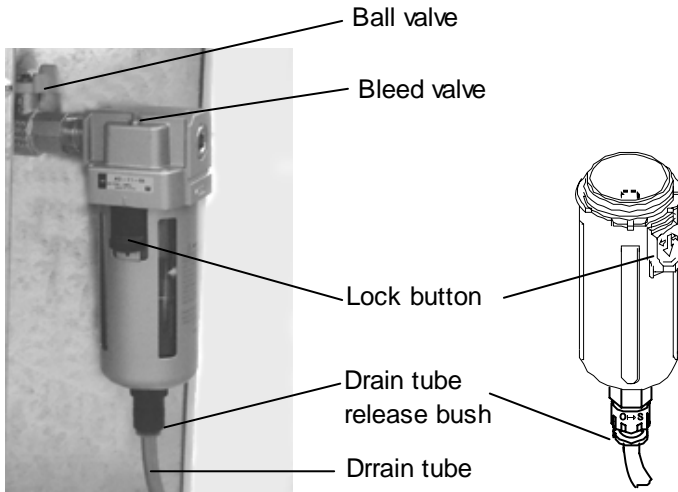

- Close the ball valve.
- Open the bleed valve by turning it anticlockwise to release air left in the product.
- Remove the drain tube from the case assembly.
- Hold the case assembly lightly and pull down the lock button with thumb. Then, turn the case assembly to the left (or right) to 45° to align the marks, Release your thumb from the lock button and slowly pull down the case assembly (vertically) to remove it.
- Pour solution of neutral detergent into the case assembly and shake it well to clean.
- Check the case O-ring for damage such as scratches, twisting or foreign particles attached to it. Then, apply grease thinly and fit it in the groove in the case assembly.
- Fit the case assembly to the auto drain body. Turn it until the lock button clicks
- Try to turn the case assembly lightly and check that it does not turn. If it turns, start with fitting the case assembly to the body again.
- Close the bleed valve by turning it clockwise and fit the drain tube as it was.
- Open the ball valve.
- If the case assembly is damaged or very dirty, replace it with a new one.

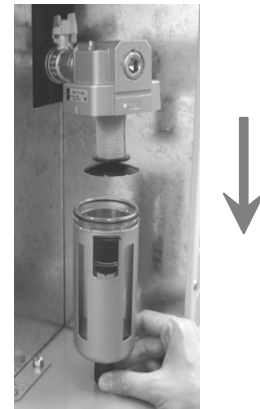

Pull down the case assembly slowly

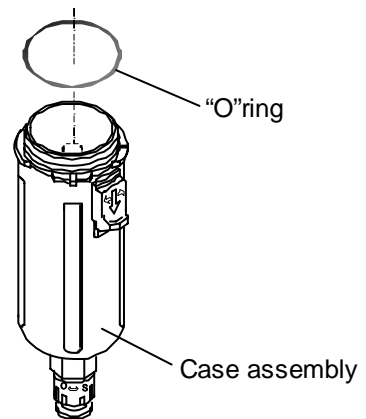

5

Troubleshooting

5 - 1 Cause and countermeasure of errors

Should any problem occur, inspect the following table, and if the problem cannot be solved, shut off the power supply and then contact one of our sales offices for further instructions.

Problem	Probable Causes	Remedy
Air dryer does not operate and running lamp does not light on, even switch is ON.	Power cord or plug is in loosening state or completely pulling out.	Perform proper connection on the power cord and plug.
	Circuit breaker is OFF.	Confirm whether the proper capacity of the circuit breaker is used. It is not possible to restart the air dryer within 3 minutes after shutdown. Wait for 3 minutes before restarting. Resume the operation after resetting the circuit breaker to ON. If the circuit breaker still trips to OFF, failure of electrical insulation may have occurred. Remove the power supply and contact one of our agents for further instructions.
	Connect the 3-phase power supply incorrectly. (Applicable to products using the 3-phase power supply.)	Replace 2 wires (R phase and T phase) among 3 each other.
Running lamp extinguishes and compressor stops during operation but resumes normal operation illuminating the lamp after a period of time.	Installation place is poorly ventilated. Ambient temperature is too high.	Improve the ventilation system to lower the ambient temperature. Reset the protective circuit referring to "5-2 How to reset the thermal relay and high pressure switch".
	The ventilation grilles are obstructed by wall or clogged with dust.	Install the air dryer more than 40cm away from the wall. Clean the ventilation grilles once a month. Reset the protective circuit referring to "5-2 How to reset the thermal relay and high pressure switch".
	Temperature of the compressed air is too high.	Improve the ventilation system around air compressor or make ambient temperature around air compressor low to lower the temperature of discharge from compressor. Reduce the temperature of the compressed air by installing an additional after-cooler after air dryer. Reset the protective circuit referring to "5-2 How to reset the thermal relay and high pressure switch".
	The power supply voltage changes largely.	Install a power supply transformer and review the power supply to keep the voltage adequate value. Allowable fluctuation of the power supply voltage is +/-10% at max. of the rated voltage. Reset the protective circuit referring to "5-2 How to reset the thermal relay and high pressure switch".
Evaporation thermometer points the value exceeding a green range under the condition where no hot wind blows out from the ventilation port (exhaust port) at right side face. (Refrigerating compressor stops with light on.)	Installation place is poorly ventilated. Ambient temperature is too high.	Improve the ventilation system to lower the ambient temperature.
	The ventilation grilles are obstructed by wall or clogged with dust.	Install the air dryer more than 40cm away from the wall. Clean the ventilation grilles once a month.
	Temperature of the compressed air is too high.	· Improve the ventilation system around air compressor or make ambient temperature around air compressor low to lower the temperature of discharge from compressor. Reduce the temperature of the compressed air by installing an additional after-cooler after air dryer.

Evaporation thermometer points the value exceeding a green range under the condition where no hot wind blows out from the ventilation port (exhaust port) at right side face.	Installation place is poorly ventilated. Ambient temperature is too high.	Improve the ventilation system to lower the ambient temperature.
	The ventilation grilles are obstructed by wall or clogged with dust.	Install the air dryer more than 40cm away from the wall. Clean the ventilation grilles once a month.
	Temperature of the compressed air is too high.	Improve the ventilation system around air compressor or make ambient temperature around air compressor low to lower the temperature of discharge from compressor. Reduce the temperature of the compressed air by installing an additional after-cooler after air dryer.
Moisture occurs downstream of the compressed air lines.	Bypass valve of air dryer is not fully closed.	Close the valve completely.
	Drain is not discharged from auto drain properly.	Check if the drain pipe has been raised up or bent. Check auto drain. Check auto drain strainer.
	Confluence of piping with another unit without air dryer.	Install air dryer on the line that does not have it. Separate two lines not to converge.
Large pressure drop	IN / OUT valve on the air dryer side is not fully opened.	Open IN/OUT valve thoroughly.
	Filter that is installed separately in compressed air line is clogged.	Replace the filter element. (Follow the instruction manual of each individual device.)

5 - 2 How to reset the thermal relay and high pressure switch

If light goes off during operation and refrigerating compressor stops, the thermal relay or high pressure switch (for only the IDU55E and IDU75E) to protect the refrigerating compressor starts operating and needs to be reset manually. For the position of the thermal relay and high pressure switch, refer to page 1-1.

Remove causes to start the thermal relay or high pressure switch referring to "5-1 Cause and countermeasure for errors".

 Danger
Be sure to turn off the switch with light of the body.

How to reset a thermal relay

Turn off the switch with lamp of the body.

Take off the front panel. The thermal relay as shown on right figure can be found on the power supply terminal base.

Confirm that a green indication does not appear at an indication window of thermal relay.

If the green indication appears, there are other possible causes and contact SMC with remaining the power supply on.

Press the blue reset button and confirm that the green indication comes to appear at the indication window.

Put back the front panel.

When the switch with lamp is turned on, the product will restart operation.

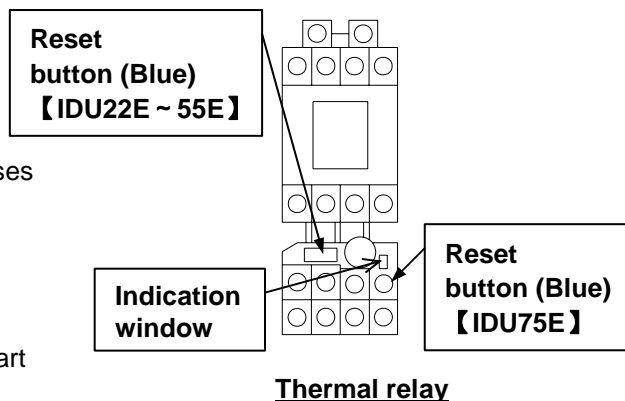

How to reset a high pressure switch

Turn off the switch with lamp of the body.

Take off the front panel. The high pressure switch can be found at upper right part of power supply terminal base.

Press the red rest button.

Put back the front panel.

When the switch with lamp is turned on, the product will restart operation.

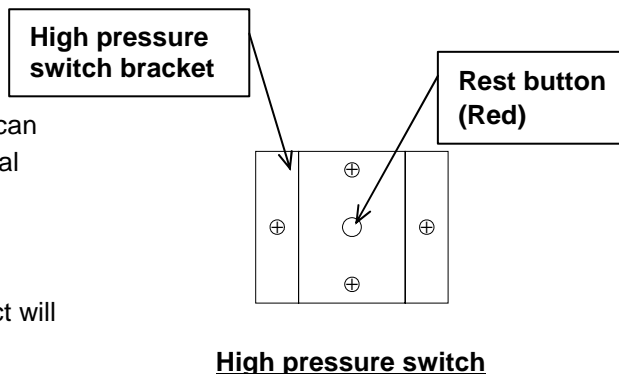

6 References

6-1 Specifications

Specification		Model	IDU22E-30	IDU37E-30	IDU55E-30	IDU75E-30
Rated Condition	Air Flow Rate m ³ /min (ANR)(Note 1)	50Hz	3.9	5.7	8.4	11
		60Hz	4.3	6.1	9.8	12.5
	Operating Pressure	MPa	0.7			
	Inlet Air Temperature		55			
	Ambient Temperature		32			
	Pressurized Dew Point		10			
Operating Range	Working Fluid		Compressed Air			
	Inlet Air Temperature		5 ~ 80			
	Inlet Air Pressure	MPa	0.15 ~ 1.0			
	Ambient Temperature		2 ~ 40 (Relative Humidity of 85% or less)			
Electrical Specification	Power source (Note 4)	Phase	Three			
		Voltage	V AC200(50Hz) / AC200,220(60Hz)			
	Operating current(Note 2)	A	4.2 / 4.8	6.3 / 6.8	8.2 / 9.3	
	Power consumption(Note 2)	W	1100 / 1450	1530 / 2000	2200 / 2850	
	Circuit Breaker(Note 3)	A	10			
Condenser		Air cooling				
Refrigerant		R407C (HFC)				
Refrigerant Charge	g	470±10	830±10	550±10	745±10	
Air IN/OUT Connection		R1	R1· 1/2	R2		
Drain Connection	mm	10				
Coating Color		Panel : Urbanwhite 1 Base : Urbangray 2				
Weight	kg	90	130	160	166	
Applicable Compressor(Standard)	kW	22	37	55	75	

Note1: The data for m³/h (ANR) is referring to the conditions of 20°C, 1atm . pressure & relative humidity of 65%.

Note 2: The value is that of under specified condition.

Note 3: Install GFCI breaker with sensivity of 30mA.

Note 4: When short period power shortage (including instantly recovered shortage) is recovered, it may take a longer starting period than usual starting or may not start due to the protective devices.

6-2 External Dimentions

IDU22E ~ 75E

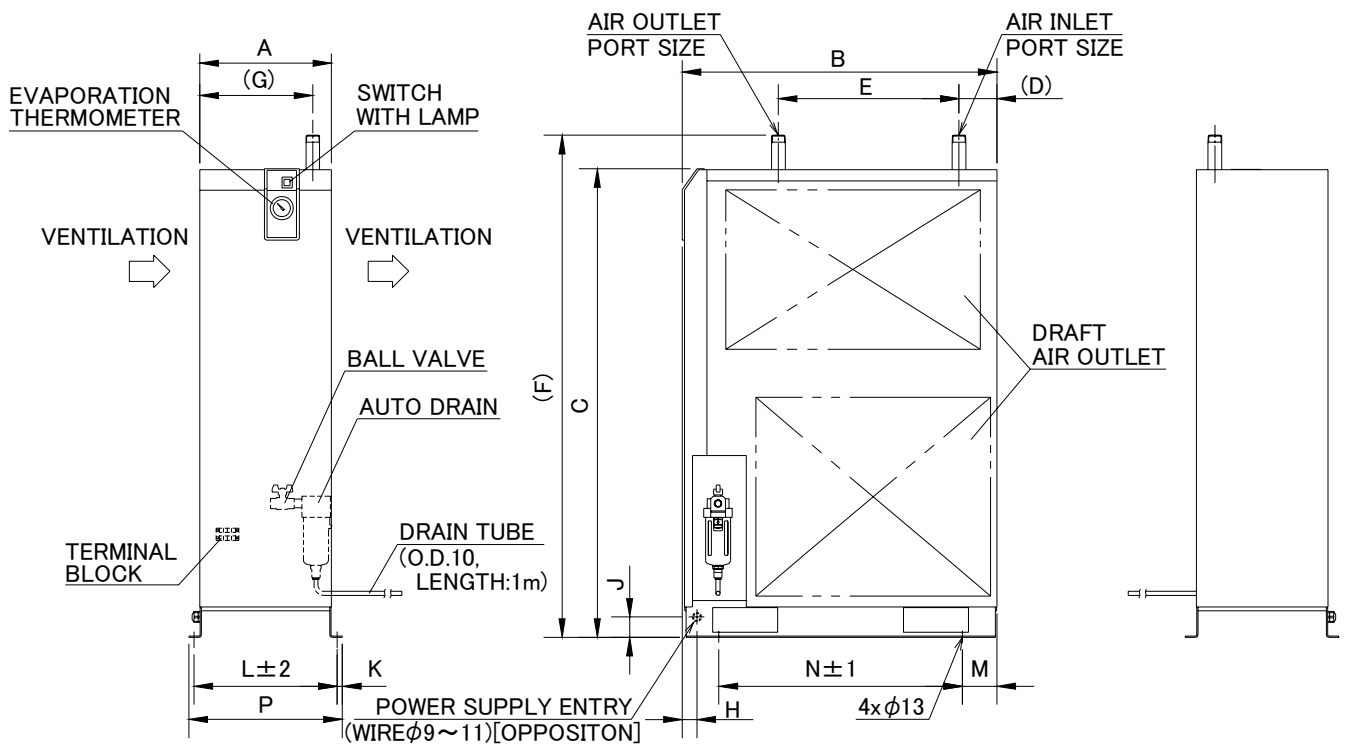

measure : mm

Model	Port size	A	B	C	D	E	F	G	H	J	K	L	M	N	P
IDU22E	R1	325	775	1153	93	445	1235	279	46	50	13	353	85	600	379
IDU37E	R1·1/2	360	855	1258	64	550	1350	290				388		680	414
IDU55E	R2	470		1345	53	530	1440	360	30	70	500	75	700	526	
IDU75E			1480	1575											

6-3 Electrical Circuit

IDU22E, 37E-30 (3 phase AC200V)

IDU55E-30 (3 phase AC200V)

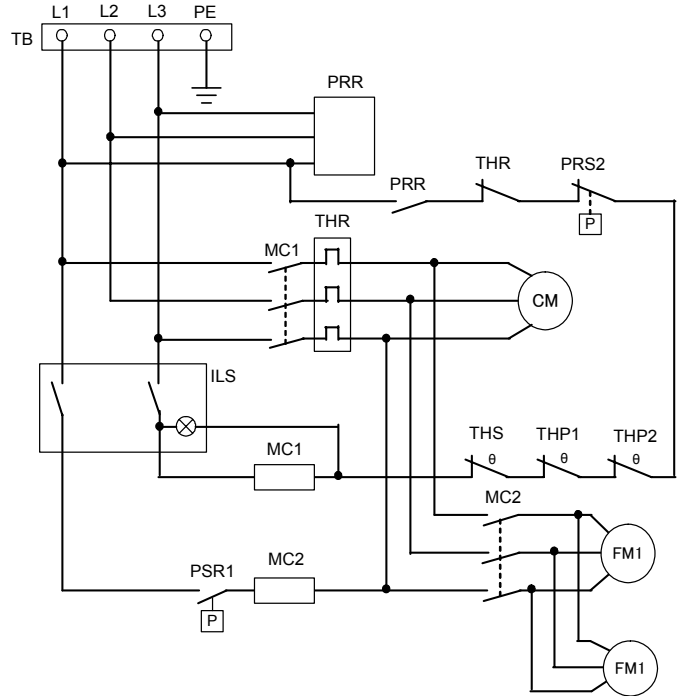
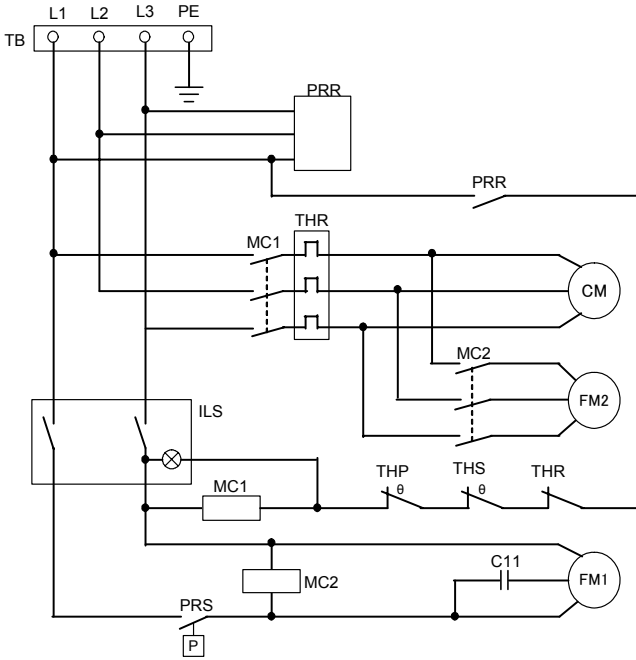

IDU75E-30 (3 phase AC200V)

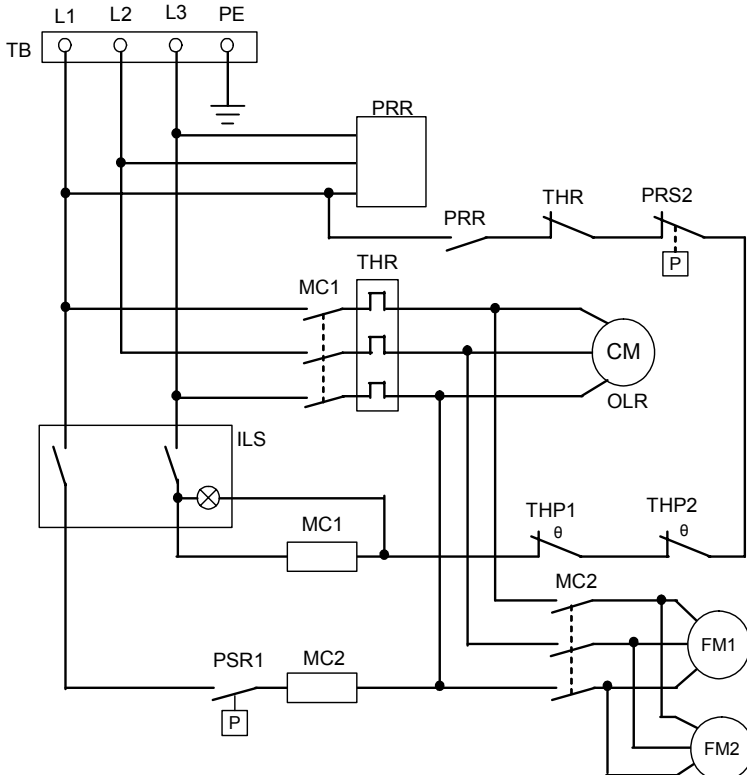

SYMBOL	DESCRIPTION
CM	Compressor Motor
FM1,FM2	Fan Motor For Condensor
MC1,MC2	Magnetic Contactor
PRS,PRS1	Pressure Switch
PRS2	High Pressure Switch
ILS	Switch with Lamp
THR	Thermal Relay
TB	Terminal Block

6 - 4 Compressed Air and Refrigerant Circuit / Operation Principles

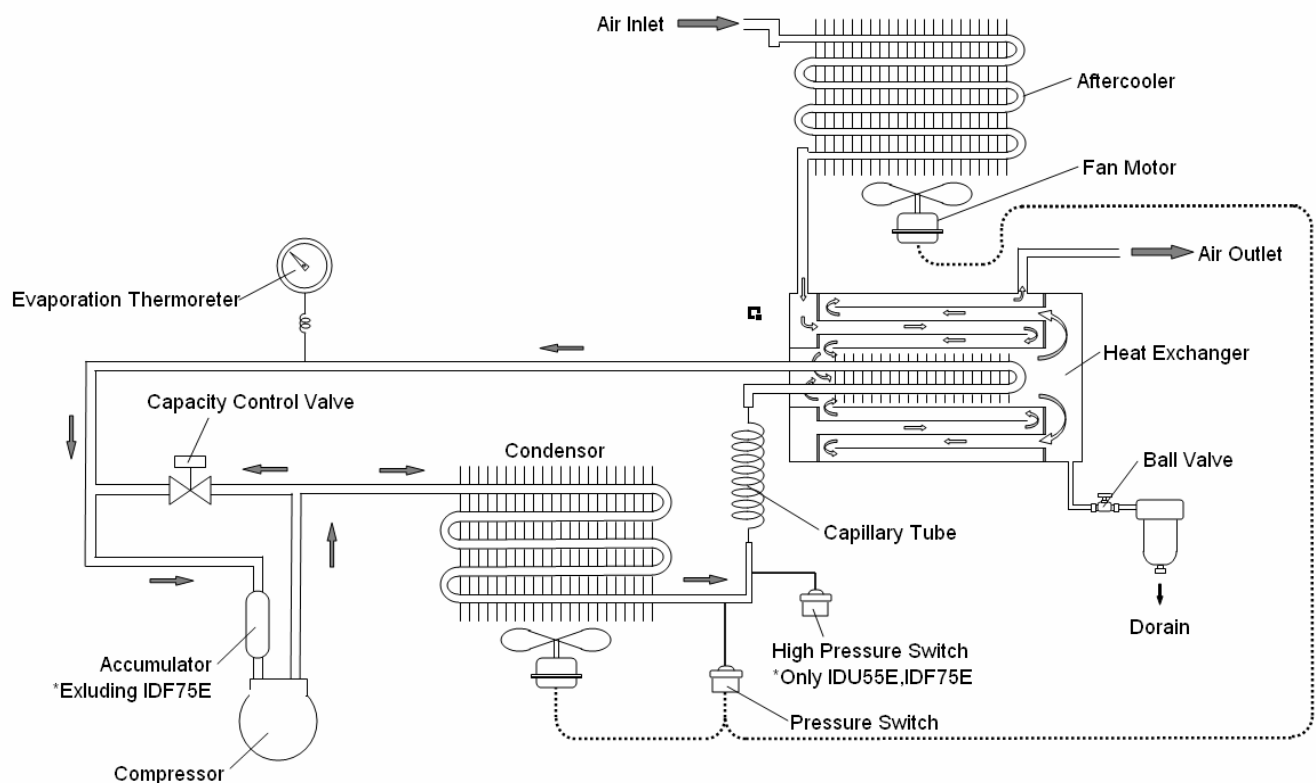

Compressed Air Circuit

Hot and humid air which has come in an air dryer firstly enters air-cooled aftercooler part, and is cooled. Then, it enters reheating part and exchanges its heat with dehumidified cold air and becomes cooler. Then, it enters cooling part and gives its heat to cold fleon, which cools and dehumidifies further, and separates its moisture. Finally, it exchanges its heat with hot and humid air which comes in the air dryer and it goes out from the air dryer as warm and dry air.

Refrigerant Circuit

The fluorocarbon charged in the refrigerant circuit is compressed by the compressor and cooled by the condenser to become liquid. Then, going through the capillary tube, it is decreased the pressure to reach a low temperature. Passing through the cooler part, it draws heat from compressed air and intensely boils. Finally it is inhaled into the compressor again. The capacity control valve opens to prevent dew drops from freezing when compressed air is cooled enough.