



# Operation Manual

PRODUCT NAME

## Refrigerated Air Dryer

MODEL

**IDF100F-30-      , IDF125F-30-  
IDF150F-30-**

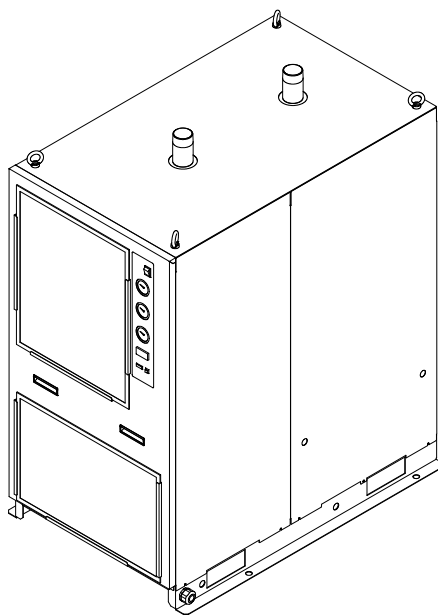

This manual is intended to explain the installation and operation of the product. Only people who understand the basic operation of the product, or have basic knowledge and ability to handle industrial machinery, are allowed to work on the product.

**Keep this manual available whenever necessary.**

© 2012 SMC CORPORATION All Rights Reserved.

# SMC Corporation

## Foreword

Thank you for purchasing SMC's refrigerant type air dryer (hereinafter referred to as the "product").

For safety and long life of the product, be sure to read this Operation Manual (hereinafter referred to as the "manual") and clearly understand the contents.

- The instructions described in this manual must be followed in addition to ISO 4414\*1) and JIS B 8370\*2) and other safety regulations.
  - \*1) ISO4414: Pneumatic fluid power – Recommendations for the application of equipment to transmission and control systems.
  - \*2) JIS B 8370: General rules for pneumatic equipment.
- This manual is intended to explain the installation and operation of the product. Only people who understand the basic operation of the product through this manual, or who install and operate industrial machinery and have basic knowledge and ability to handle such equipment, are allowed to work on the product.
- This manual and other documents attached to the product do not constitute a contract, and will not affect any existing agreements or commitments.
- It is strictly prohibited to copy this manual entirely or partially for use by a third party without prior permission from SMC.

**Note: This manual is subject to change without prior notice.**

# Table of Contents

## Foreword

### Chapter i Safety Instructions

<b>i . 1</b>	<b>Warning: Before using this product</b> .....	i - 1
i . 1. 1	Danger, Warning and Caution.....	i - 1
<b>i . 2</b>	<b>Hazard classification and locations of hazard labels</b> .....	i - 2
i . 2. 1	Hazards.....	i - 3
i . 2. 2	Warning related to electricity.....	i - 3
i . 2. 3	Warning related to high temperature .....	i - 3
i . 2. 4	Warning related to rotating objects .....	i - 3
i . 2. 5	Warning related to pneumatic circuit .....	i - 4
i . 2. 6	Location of hazard label.....	i - 4
i . 2. 7	Caution related to refrigerant.....	i - 5
i . 2. 8	Caution related to handling.....	i - 6
i . 2. 9	Other labels.....	i - 6
<b>i . 3</b>	<b>Waste disposal</b> .....	i - 7
<b>i . 4</b>	<b>Limited warranty and Disclaimer / Compliance Requirements</b> .....	i - 8

### Chapter 1 Name and Function of Parts

<b>1 . 1</b>	<b>Part number of product</b> .....	1 - 1
<b>1 . 2</b>	<b>Options of product</b> .....	1 - 2
1. 2. 1	Anti-corrosive treated copper tube (option C).....	1 - 2
1. 2. 2	Medium pressure type (option K).....	1 - 2
1. 2. 3	Metal name plate (option P).....	1 - 2
1. 2. 4	Ground fault circuit interrupter (option R) .....	1 - 2
1. 2. 5	Timer type solenoid valve with auto drain (option V).....	1 - 2
1. 2. 6	Ventilation direction.....	1 - 2
<b>1 . 3</b>	<b>Name and function of parts</b> .....	1 - 3

### Chapter 2 Transportation and installation

<b>2 . 1</b>	<b>Transportation</b> .....	2 - 1
<b>2 . 2</b>	<b>Installation</b> .....	2 - 2
2. 2. 1	Environment.....	2 - 2
2. 2. 2	Fixing of product .....	2 - 3
2. 2. 3	Change of ventilation direction .....	2 - 4
2. 2. 4	Pneumatic piping .....	2 - 5
2. 2. 5	Draining piping .....	2 - 5
2. 2. 6	Draining piping for condensed water .....	2 - 6
2. 2. 7	Electric wiring.....	2 - 7
<b>2 . 3</b>	<b>Reinstallation of the product</b> .....	2 - 9

### Chapter 3 Start and stop

<b>3 . 1</b>	<b>Before starting</b> .....	3 - 1
<b>3 . 2</b>	<b>Start</b> .....	3 - 1
<b>3 . 3</b>	<b>Stop</b> .....	3 - 2

<b>3 . 4</b>	<b>Precautions for restarting operation</b> .....	3 - 2
<b>3 . 5</b>	<b>Check items after starting</b> .....	3 - 2
<b>3 . 6</b>	<b>Display of controller</b> .....	3 - 3
<b>3 . 7</b>	<b>Signal output</b> .....	3 - 4

#### **Chapter 4 Checks and inspection**

<b>4 . 1</b>	<b>Daily check</b> .....	4 - 1
<b>4 . 2</b>	<b>Parts requiring regular maintenance</b> .....	4 - 1
4 . 2 . 1	Cleaning of filter at ventilation port (suction port) .....	4 - 1
4 . 2 . 2	Maintenance of auto drain .....	4 - 1
4 . 2 . 3	Maintenance of timer type solenoid valve with auto drain (Option V) .....	4 - 4
4 . 2 . 4	Maintenance of operating time accumulator .....	4 - 4

#### **Chapter 5 Troubleshooting**

<b>5 . 1</b>	<b>Troubleshooting</b> .....	5 - 1
<b>5 . 2</b>	<b>Reset of protective equipment</b> .....	5 - 3
<b>5 . 3</b>	<b>Reset of ground fault circuit interrupter (Option R)</b> .....	5 - 4

#### **Chapter 6 References**

<b>6 . 1</b>	<b>Specification table</b> .....	6 - 1
<b>6 . 2</b>	<b>Outer dimensions</b> .....	6 - 2
<b>6 . 3</b>	<b>Electric wiring diagram</b> .....	6 - 5
<b>6 . 4</b>	<b>Pneumatic and refrigerant circuits and their functions</b> .....	6 - 7
<b>6 . 5</b>	<b>Consumable parts and regular maintenance parts</b> .....	6 - 8

---



## Safety Instructions



Before using the product be sure to read and understand all the important actions highlighted in this manual.

### **i.1 Warning: Before using this product**

This chapter is intended to specifically describe the safety related issues for handling the product. Read this before handling the product.

- The product is designed to dehumidify compressed air. SMC does not take any responsibility for any problems that may arise from using the product for other purposes.
- The product is operated at high voltage and contains components which become hot and rotate. If a component needs to be replaced or repaired, contact a specialized vendor for parts and service. All personnel who work with or around the product should read and understand the safety related information in this manual carefully before starting work.
- This manual is not a comprehensive manual covering safety and health related issues. This should be handled by a person in charge of safety training.
- All personnel who work with or around the product should have sufficient knowledge about the dangers inherent to the product and be trained in safety measures.
- The safety manager is responsible for strictly observing safety standards, but responsibility in respect to safety standards during daily work resides with each individual operator and maintenance personnel.
- The operator and maintenance personnel should consider work places and environments for each task with due consideration of safety issues.
- It is necessary to undergo appropriate general safety training before being trained about this product. Training without having sufficient knowledge about safety is very dangerous. Training must not be conducted without consideration to safety.
- This manual must be kept available to the operator whenever necessary.
- If the product is subjected to a short power outage (including voltage sag), it may take a long time to start operating normally or be unable to restart normally due to the protective equipment triggered after the power is recovered. In that case, turn off the switch with lamp on the body once, and reset the protective equipment circuit referring to "5.2 Reset of protective equipment". Sudden restart of the product is possible after the recovery of power, so be sure to turn off the switch with lamp when removing the cover panel of the product.

### **i.1.1 Danger, Warning and Caution**

The instructions given in this manual aim to assure the safe and correct operation of the product, and to prevent injury of operators or damage to the product. These instructions are grouped into three categories, "Danger", "Warning" and "Caution", which indicate the level of hazard, damage and also the degree of emergency. All safety critical information should be carefully observed at all times.

DANGER, WARNING and CAUTION signs are in order according to severity (DANGER> WARNING> CAUTION). The signs are explained on the following page.



### **Danger**

**"Danger" indicates a hazard with a high level of risk which will result in death or serious injury if an operator performs incorrect handling during the operation and maintenance of the product or does not follow the instructions necessary to avoid it.**



## Warning

“Warning” indicates a hazard with a medium level of risk which will result in death or serious injury if an operator does not follow the specified procedures during the operation or maintenance of the product or does not follow the instructions necessary to avoid it.



## Caution

“Caution” indicates a hazard of a low level of risk which will result in minor and moderate injury or damage to product and equipment if an operator does not follow the specified procedures during the operation and maintenance of the product or does not follow the instructions to avoid it.

### i.2 Hazard classification and locations of hazard labels

The product has various potential hazards and they are marked with warning labels. Read this section before starting any work on the product.



## Warning

- Only trained personnel should handle the product.
- Only people who have sufficient knowledge and experience about the product and its accessories are allowed to carry out transportation, installation and maintenance work.
- Only maintenance personnel or people who have sufficient knowledge and experience are allowed to open the cover panels of the product.



## Warning

If any error occurs, take measures as instructed in this manual.



## Warning

- If any error occurs, do not start operating the product.
- If any error occurs, immediately stop the product, and call for the maintenance personnel or a person who has sufficient knowledge and experience about the product and its accessories.

### i.2.1 Hazards

The hazards inherent to the product are as follows.

#### **Warning related to electricity**

The product is operated at a high voltage and can cause electrical shock internally. This risk is indicated with the mark  in addition to “Danger”, “Warning” and “Caution” on the product or in this manual.

#### **Warning related to heat**

The product has surfaces that can reach high temperatures during operation, which may cause burns. This risk is indicated with the mark  in addition to “Danger”, “Warning” and “Caution” on the product or in this manual.

#### **Warning related to rotating objects**

The product has parts that will rotate during operation, which may cause fingers to get caught and injured. This risk is indicated with the mark  in addition to “Danger”, “Warning” and “Caution” on the product or in this manual.

### i.2.2 Warning related to electricity



The product is operated at a high voltage and contains the power supply isolated by the cover panel.

Do not operate the product without cover panels fitted.

Only people who have sufficient knowledge and experience are allowed to perform work and inspections in locations with the power supplied.



#### **Warning**

- Fully read and understand the contents of the hazard labels.
- Do not peel or rub off the hazard labels.
- Carefully confirm where the hazard labels are affixed.

### i.2.3 Warning related to high temperature



#### **Warning**

The product has surfaces that can reach high temperatures during operation, and cause burns by contact. Even after the power is turned off, there can still be residual heat in the product, which may cause burns. Do not start work until the temperature of the surfaces has fallen below 50°C.

### i.2.4 Warning related to rotating objects



#### **Warning**

The product has parts that can rotate during operation, and cause injury by contact. Also, the rotating parts might stop rotating temporarily and restart during operation. Do not perform work during operation.

### i.2.5 Warning related to pneumatic circuit



#### Warning

Be sure to release compressed air from the product and ensure the internal pressure is zero before replacing or cleaning the parts of the product. If the compressed air is left in the product, when some part is loosened, it may cause sudden lurching or other unexpected accidents.

### i.2.6 Location of hazard label



#### Warning

- Fully read and understand the contents of the hazard labels.
- Do not peel or rub off the hazard labels.
- Carefully confirm where the hazard labels are affixed.

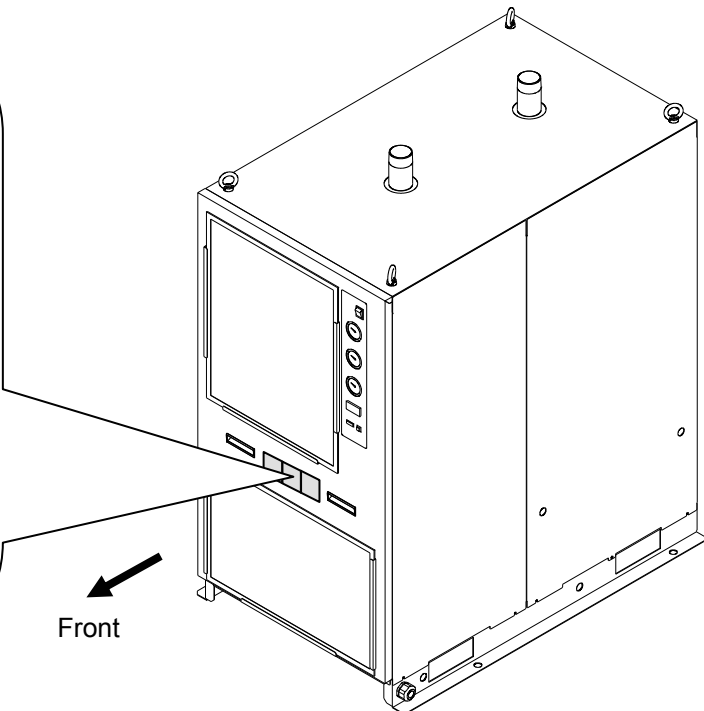

### i.2.7 Caution related to refrigerant



## Caution

- The product uses hydro-fluorocarbon type refrigerant (HFC).
- The product is categorized as category 1 under the fluorocarbon recovery and destruction law in Japan.  
The release of refrigerant into the atmosphere is banned by law. When the product is serviced, the refrigerant must be recovered using “refrigerant recovery equipment” and disposed of by a specialist disposal company. Only people who have sufficient knowledge and experience about the product and its accessories are allowed to recover the refrigerant.
- Only maintenance personnel or people who have sufficient knowledge and experience are allowed to open the cover panels of the product.
- The type and necessary amount of HFC can be found on the specification label explained on page 6 of Section i.

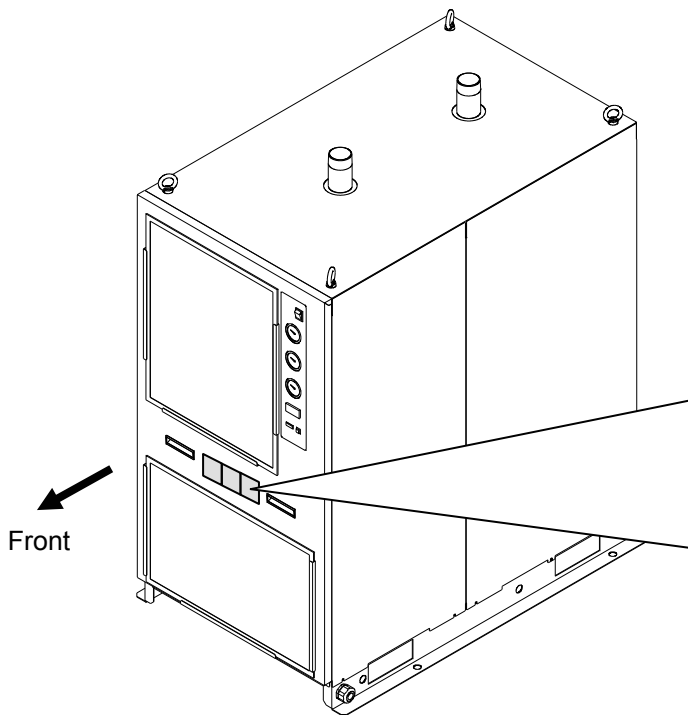

Fluorocarbon Collection and Destruction Law in Japan  
フロン回収破壊法第一種特定製品

This product uses

Fluorocarbon (HFC) as a refrigerant.

- 1 It is strictly forbidden to emit Fluorocarbon to the atmosphere.
- 2 When disposing this product, Fluorocarbon must be collected in an appropriate manner.
- 3 The kind of Fluorocarbon and the amount used in this product is printed on the name label.

この製品には冷媒として、  
フロン類(HFC)が使われています。

- 1 フロン類をみだりに大気中に放出することは禁じられています。
- 2 この製品を廃棄する場合には、フロン類の回収が必要です。
- 3 フロン類の種類及び数量は、型式銘板に記載されています。

### i.2.8 Caution related to handling

<span style="font-size: 1.2em; font-weight: bold; margin-left: 10px;">Warning</span>
<ul style="list-style-type: none"> <li>- Fully read and understand the contents of the hazard labels.</li> <li>- Do not peel or rub off the hazard labels.</li> <li>- Carefully confirm where the hazard labels are affixed.</li> </ul>

CAUTION 注意

- 1 Read manual before operation.
- 2 Ensure ventilation and maintenance space.
- 3 Keep water away from the product.
- 4 Secure In / Out connector with spanner during piping.
- 5 Wait 3 minutes before restart.
- 6 Ensure Running Condition / Evaporating Temp. in green zone.

---

- 1 ご使用前に必ず取扱説明書を読んでください。
- 2 通風、メンテナンススペースを確保してください。
- 3 雨や水滴がかからないようにしてください。
- 4 IN/OUTポートをスパナで固定して配管してください。
- 5 再起動は運転停止3分後に行ってください。
- 6 RUNNING CONDITION・蒸発温度計はグリーン帯で使用してください。

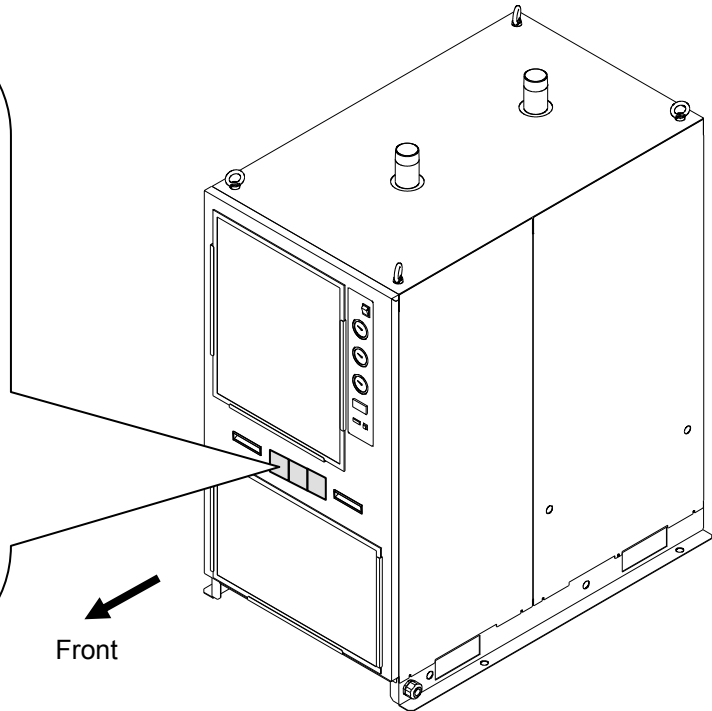

### i.2.9 Other labels

Confirm the model and specifications described in the label.

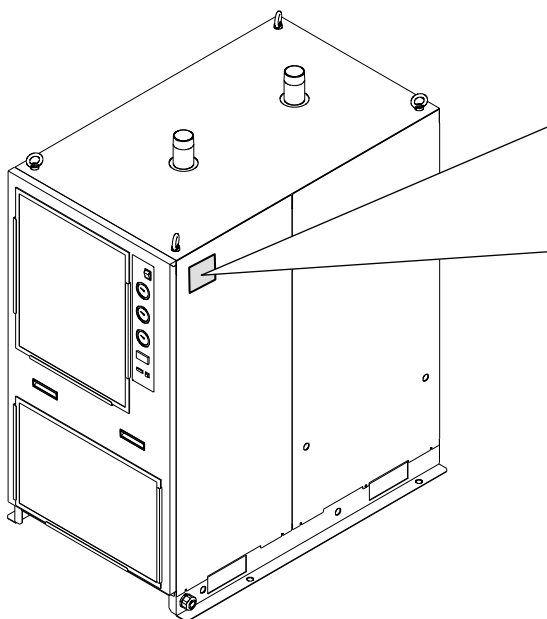

□	Model
VOLTAGE: Power supply voltage (frequency)	
RUNNING CURRENT: Operating current	
REFRIGERANT: Type of refrigerant (amount)	
WEIGHT: Weight	
MAX.PRESS.: Maximum operating pressure	
SERIAL No.: Model number	
MAKER: Manufacturing company	
<span style="margin-left: 20px;">MADE IN: Manufacturing country</span> <span style="float: right; border: 1px solid black; padding: 2px 5px;">G</span>	

### **i.3 Waste disposal**

When disposing of the product, recover the refrigerant and compressor oil contained in the refrigerant circuit.



#### **Caution**

- The product uses hydro-fluorocarbon type refrigerant (HFC).
- The product is categorized as category 1 under the fluorocarbon recovery and destruction law in Japan.
- The release of refrigerant into the atmosphere is banned by law. When the product is serviced, the refrigerant must be recovered using “refrigerant recovery equipment” and disposed of by a specialist disposal company.
- Only people who have sufficient knowledge and experience about the product and its accessories are allowed to recover the refrigerant.
- Only maintenance personnel or people who have sufficient knowledge and experience are allowed to open the cover panels of the product.
- The type and necessary amount of HFC can be found on the specification label.



#### **Caution**

- The disposal of the compressor oil must be in compliance with the bylaws or rules of the local municipality.
- Do not mix the compressor oil with domestic waste for disposal. Also, the disposal of the waste must only be conducted by specific facilities that are permitted for that purpose.
- Only people who have sufficient knowledge and experience about the product and its accessories are allowed to recover the compressor oil.
- Only maintenance personnel or people who have sufficient knowledge and experience are allowed to open the cover panels of the product. If anything is unclear, contact your local supplier or SMC.

#### **i.4 Limited warranty and Disclaimer / Compliance Requirements**

The product used subject to the following “Limited warranty and Disclaimer” and “Compliance Requirements. Read and accept them before using the product.

##### **Limited warranty and Disclaimer**

1. The warranty period of the product is 1 year in service or 1.5 years after the product is delivered. Also, the product may have specified durability, running distance or replacement parts. Please consult your nearest sales branch.
2. For any failure or damage reported within the warranty period which is clearly our responsibility, a replacement product or necessary parts will be provided. This limited warranty applies only to our product independently, and not to any other damage incurred due to the failure of the product.
3. Prior to using SMC products, please read and understand the warranty terms and disclaimers noted in the specified catalog for the particular products.

##### **Compliance Requirements**

1. The use of SMC products with production equipment for the manufacture of weapons of mass destruction (WMD) or other weapon is strictly prohibited.
2. The exports of SMC products or technology from one country to another are governed by the relevant security laws and regulation of the countries involved in the transaction. Prior to the shipment of a SMC product of a SMC product to another country, assure that all local rules governing that export are known and followed.

### **Caution**

**The Product is provided use in manufacturing industries.**  
**The product herein described is basically provided for peaceful use in manufacturing industries.**  
**If considering using the product in other industries, consult SMC beforehand and exchange specifications or a contact if necessary.**  
**If anything is unclear, contact your nearest sales branch.**

# 1 Name and Function of Parts

## 1.1 Part number of product

The part number of the product is determined as follows.

The product needs to be handled in different ways depending on the part number. Refer to “i.2.9 Other labels” and check the part number of the product.

\*1 Two or more options can be selected together.

\*2 When multiple options are selected, state them in alphabetical order.

E.g. When the IDF100F-30 is provided with options C, R and V and specified to have the ventilation direction to the right side, the part number will be **IDF100F-30-CRV1**.

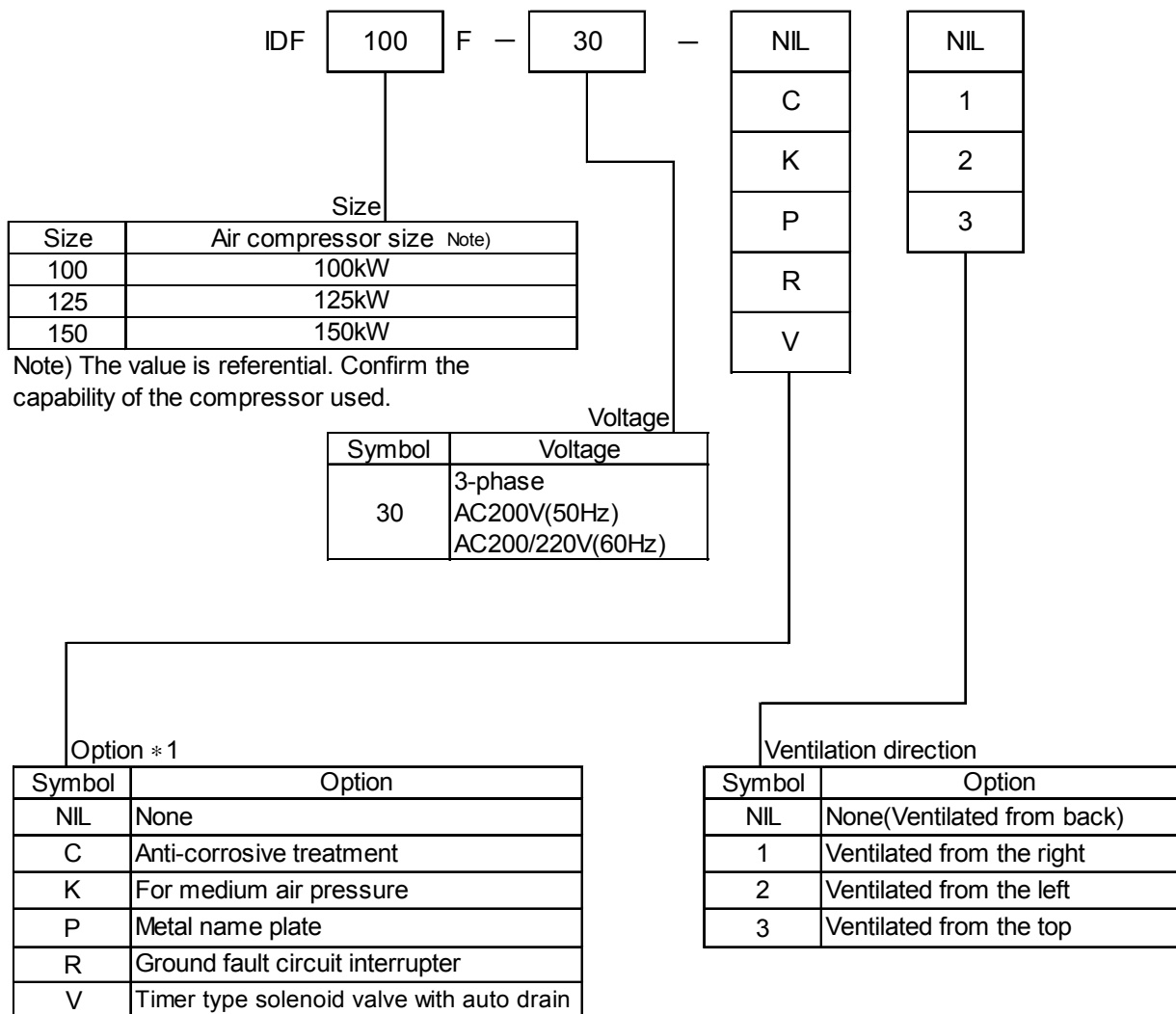

## 1.2 Options of product

### 1.2.1 Anti-corrosive treated copper tube (option C)

This is the option providing a special epoxy paint on the surface of the copper tube to prevent corrosion. The special epoxy paint is applied to the surface of the copper tube except for the part coated with the thermal insulator.

If the coating on the surface of the copper tube is damaged when the panel is removed for maintenance, the anti-corrosion treatment will lose its effect.

Pay attention not to damage the coating.

### 1.2.2 Medium pressure type (option K)

This is the option that extends the maximum operating pressure to 1.6MPa.

The internal piping material of the product is changed from nylon to metal.

### 1.2.3 Metal name plate (option P)

This is the option that changes the label identifying the model and specifications of the product to a metal plate.

### 1.2.4 Ground fault circuit interrupter (option R)

This is the option providing a built-in ground fault circuit interrupter. Should the product have over current or ground fault, the power supply will be cut off.

Breaker capacity: 30A

Sensitivity of leak current: 30mA

### 1.2.5 Timer type solenoid valve with auto drain (option V)

This is the option that controls the solenoid valve for draining with a timer.

It comes with solenoid valve protective strainer and ball valve.

The default setting of the timer is 1.5 seconds for ON and 0.5 minute for OFF.

Do not change the setting of the timer.

If it is changed, there can be water leakage from the secondary side of the product.

### 1.2.6 Ventilation direction

The direction to which the product ventilates heat is specified.

The surface with the switch with lamp is viewed as the front.

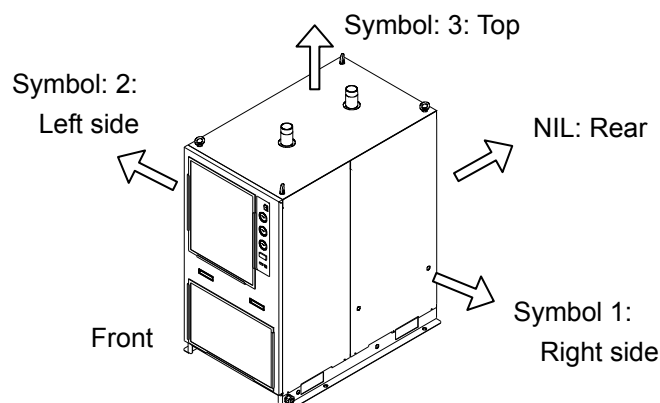

**1.3 Name and function of parts**

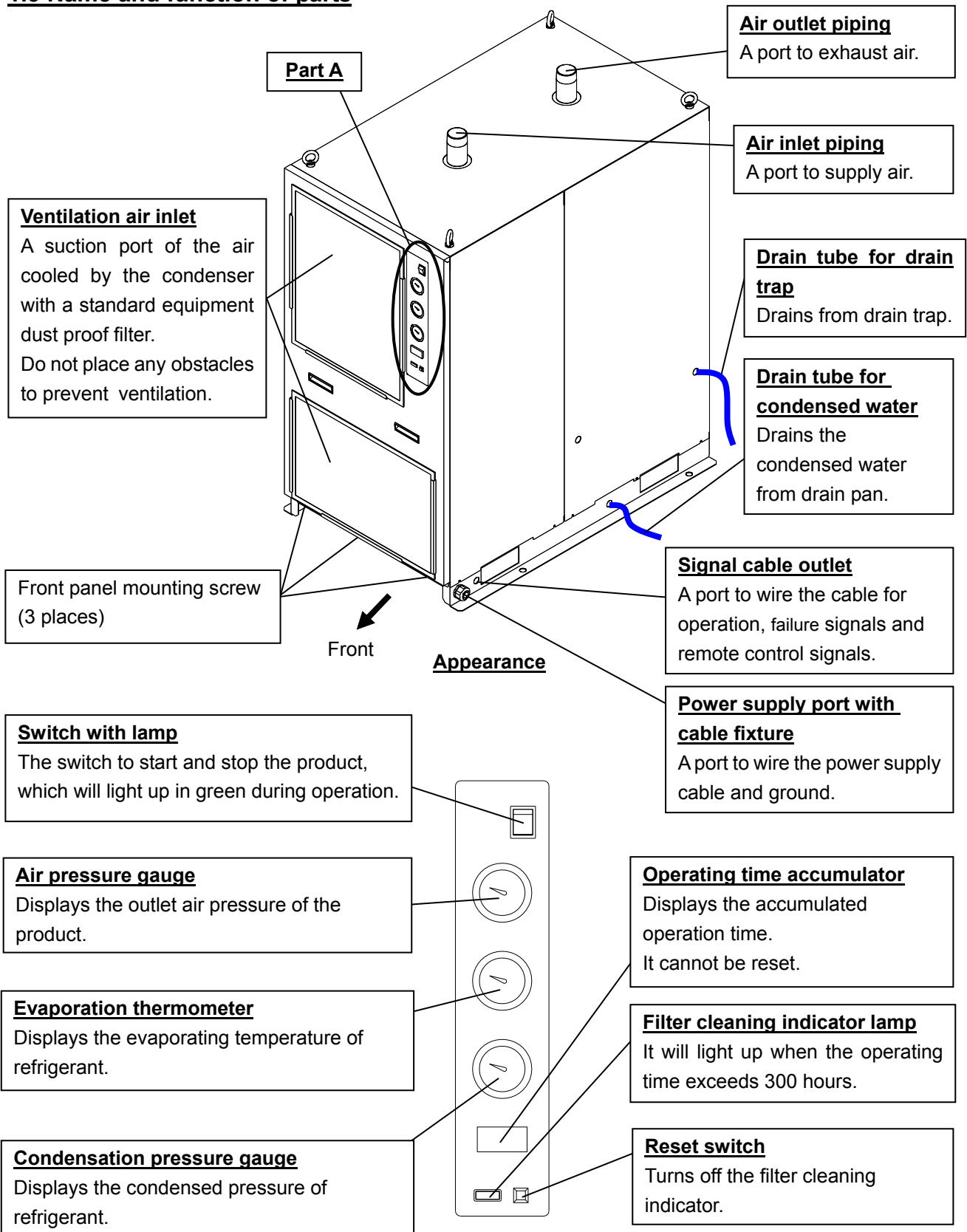

**Enlarged view of part A**

**Ventilation air outlet**  
 A port to discharge the air cooled by the condenser. Do not place any obstacles to prevent ventilation.

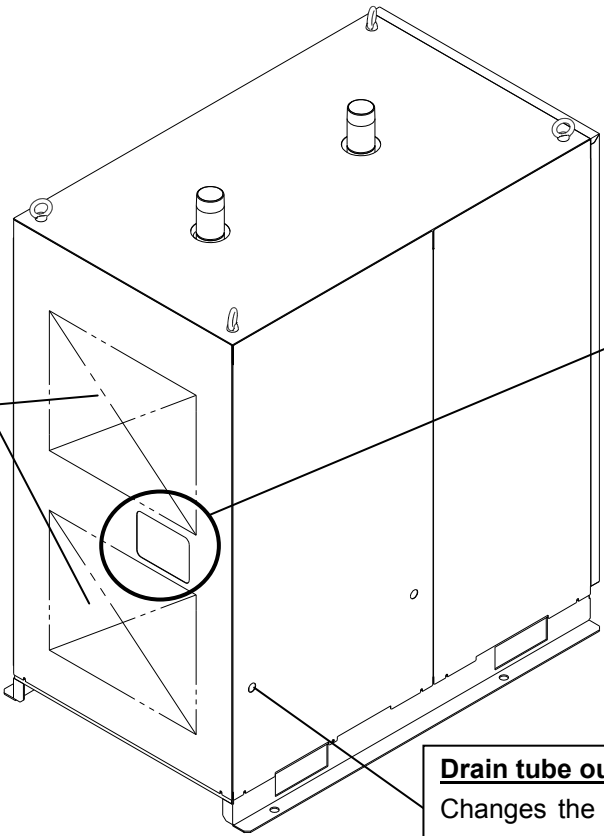

**Part B**

**Drain tube outlet**  
 Changes the direction to take out the drain tube.

**Rear**

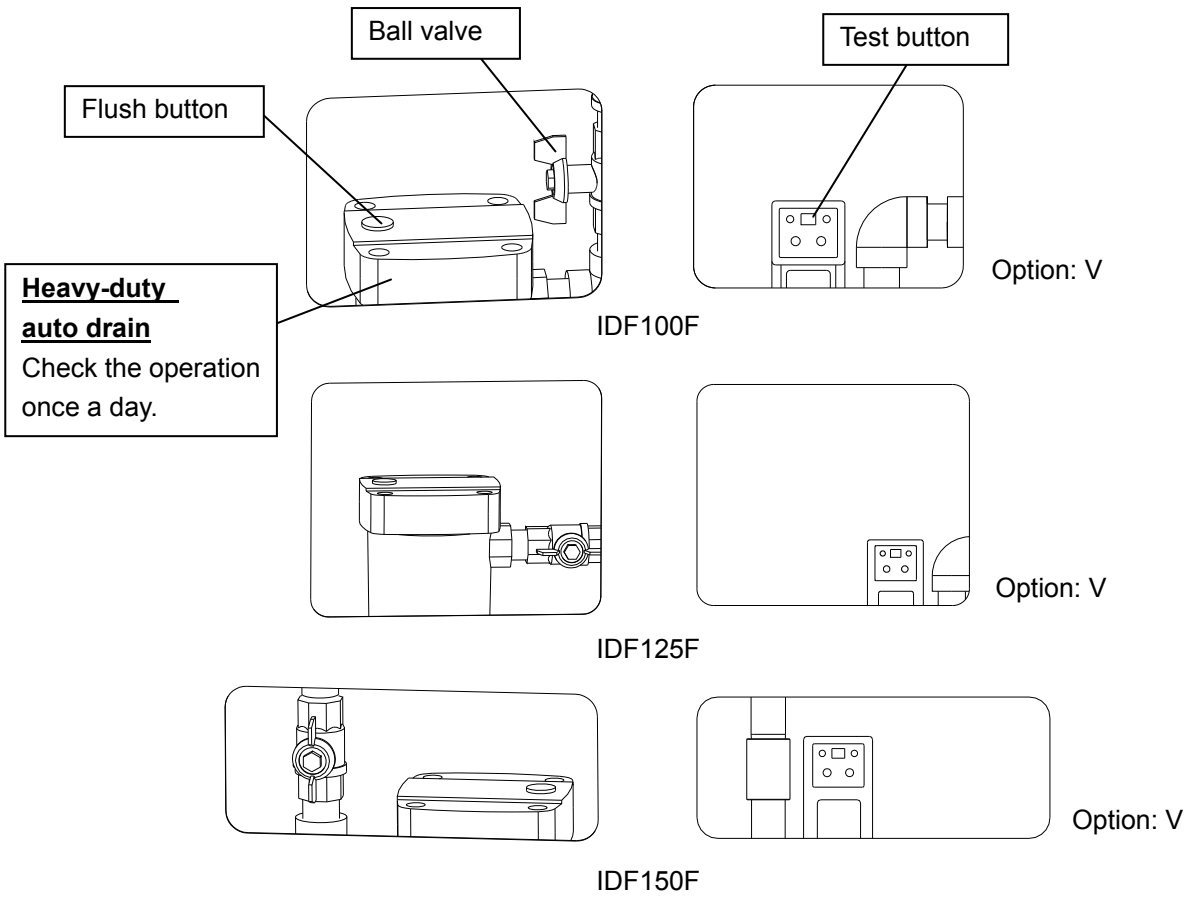

**Heavy-duty auto drain**  
 Check the operation once a day.

**Enlarged view of part B**

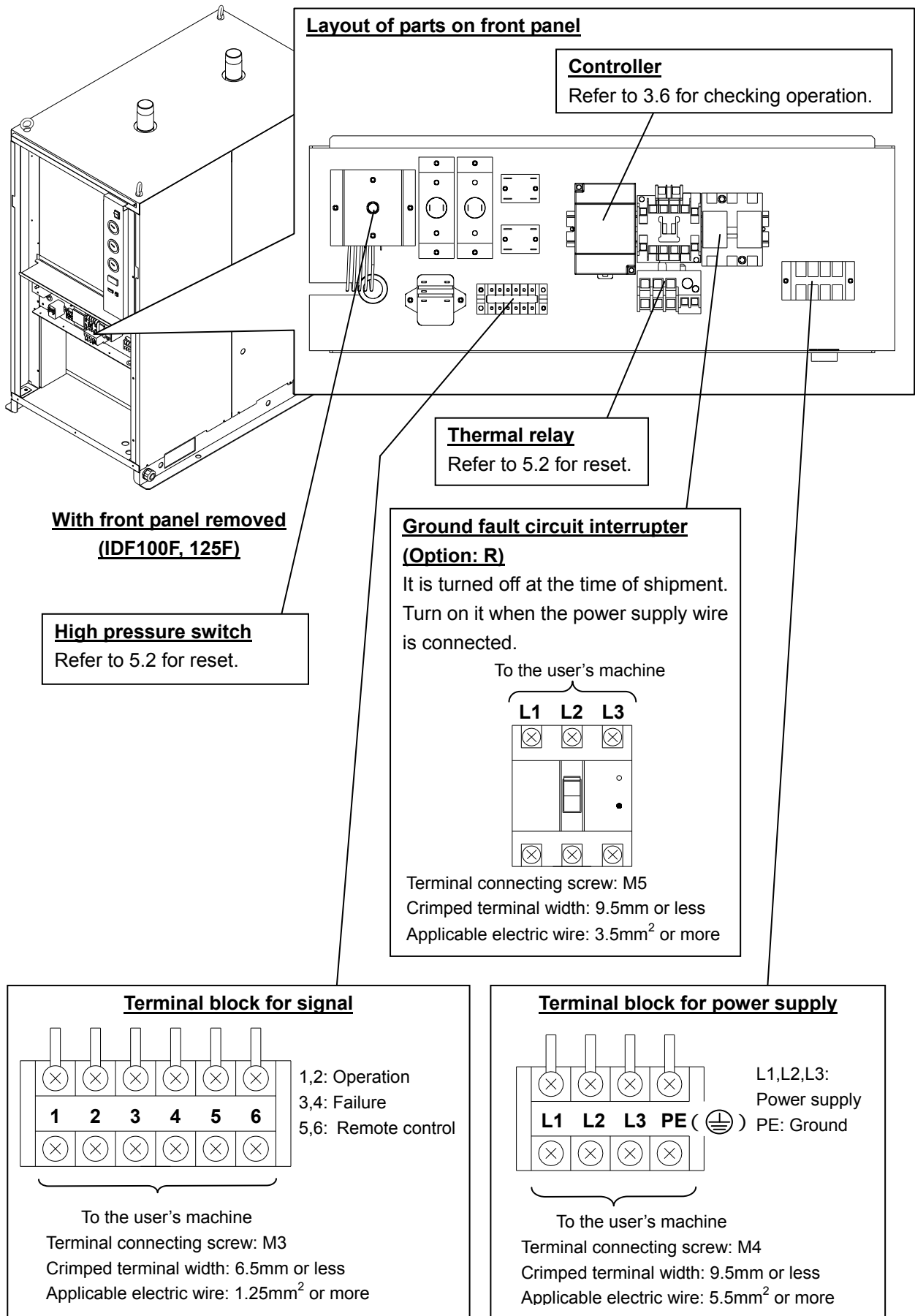

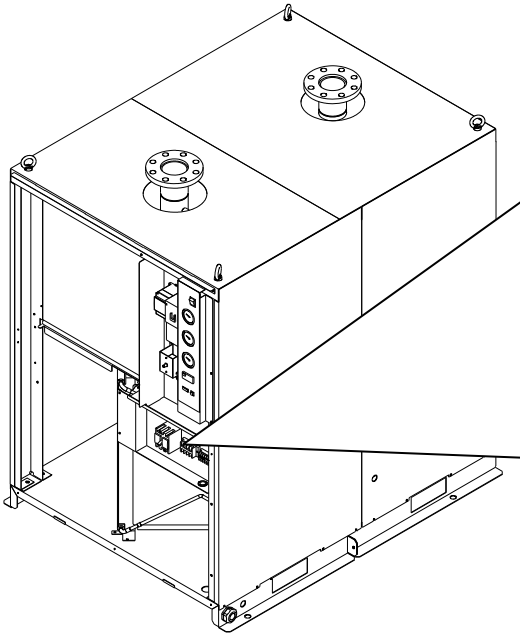

**With front panel removed  
(IDF150F)**

**Layout of parts on front panel**

**Controller**

Refer to 3.6 for checking operation.

**Thermal relay**

Refer to 5.2 for reset.

**High pressure switch**

Refer to 5.2 for reset.

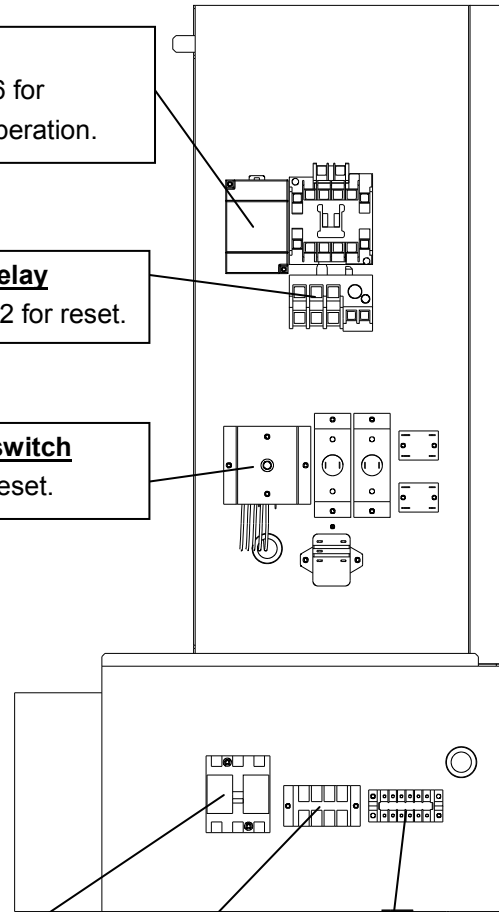

**Ground fault circuit interrupter**

**(Option: R)**

It is turned off at the time of shipment. Turn on it when the power supply wire is connected.

To the user's machine

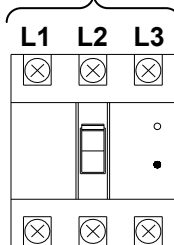

Terminal connecting screw: M5  
Crimped terminal width: 9.5mm or less  
Applicable electric wire: 3.5mm<sup>2</sup> or more

**Terminal block for power supply**

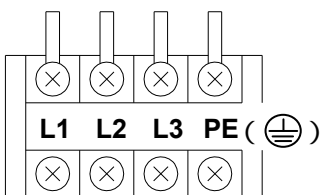

L1,L2,L3:  
Power supply  
PE: Ground

To the user's machine  
Terminal connecting screw: M4  
Crimped terminal width: 9.5mm or less  
Applicable electric wire: 5.5mm<sup>2</sup> or more

**Terminal block for signal**

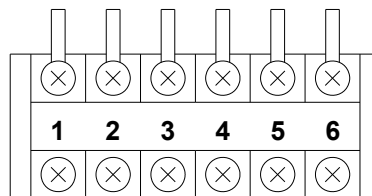

1,2: Operation  
3,4: Failure  
5,6: Remote control

To the user's machine  
Terminal connecting screw: M3  
Crimped terminal width: 6.5mm or less  
Applicable electric wire: 1.25mm<sup>2</sup> or more

# 2

## Transportation and installation

### ⚠ Warning

- Use the product in an appropriate manner, and pay attention to safety, particularly physical safety of operators, during the installation, operation, maintenance and checks of the product.
- When the product is used for a critical facility or equipment, prepare a spare product or alternative machine in case of stoppage of the product due to the operation of the protective equipment or the failure of the product itself.

### ⚠ Caution

- Only people who have sufficient knowledge and experience about the product and system are allowed to perform the transportation, installation and maintenance of the product, including dangerous work.

### 2.1 Transportation

Be sure to follow the instructions below when transporting the product.

- The product is filled with refrigerant. Transport it (by land, sea or air) in accordance with laws and regulations specified.
- When carrying the product, be careful not to let it drop or fall over. Lift it by using a fork lift or rope and lifting hook. The lifting angle should be 45° or more.
- Do not lift the product by holding the panel, fittings or piping.
- Never lay the product down for transportation. It may lead to damage to the product.

### ⚠ Warning

- The product is heavy and has potential dangers in transportation. Be sure to follow the instructions above.
- To transport the product, be sure to use a fork lift or lifting hook.

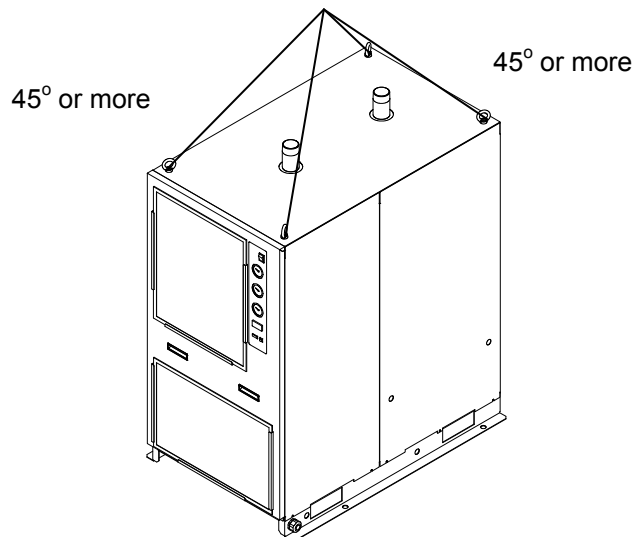

## **2.2 Installation**

### **2.2.1 Environment**

(1) Do not use or store the product under the following conditions, as these may cause breakage of the product as well as a failure of the product to operate.

- In an environment where the product will come into direct contact with rain, wind and snow or with a lot of moisture (relative humidity 85% or more).

The option B is provided for installation under a roof, but should not be used in environments where rain or snow may fall on it.

- In a location with a large quantity of dust.
- In a location containing flammable or explosive gases.
- In a location exposed to corrosive or flammable gases or solvent.

The option C is coated with a special epoxy paint on the surface of the copper tube to improve anti-corrosion resistance to corrosive gases, but cannot prevent rust completely.

And also the electric switching gears may be attacked by the corrosive gas, install the product in a location free from corrosive gases as far as possible.

- In a location where the ambient temperature is outside the following ranges.  
In operation: 2 to 45°C, In storage: 0 to 50°C (with no condensate in piping)
- In a location that is subjected to abrupt changes in temperature.
- In a location that is subjected to strong electromagnetic noise (intense electric field, intense magnetic field, or surges)
- In a location that is subjected to static electricity, or conditions where static electricity can discharge to the product.
- In a location that is subjected to strong high frequency radiation (microwaves)
- In a location that is subjected to potential lightning strikes.
- In a location with an altitude of 2,000 metres or higher.
- In a location where the product is affected by strong vibrations or impacts.
- Conditions where external force or weight is applied that could deform the product.
- In a location where there are obstacles blocking the ventilation ports of the product.
- In a location where the dryer is drawing in high temperature air that is discharged from an air compressor or other dryers.

(2) Contact SMC beforehand and take special consideration of safety measures if the product is to be used in any of the following conditions.

- Conditions and environments outside of the given specifications, or use outdoors or in a place exposed to direct sunlight.
- Installation on equipment in conjunction with atomic energy, railways, air navigation, shipping, vehicles, medical treatment or recreation equipment, or equipment in contact with food and beverages, emergency stop circuits, clutch and brake circuits in press applications, safety equipment or other applications unsuitable for the standard specifications described in the product catalog.
- An application which could have negative effects on people, property, or animals requiring special safety analysis.
- Use in an interlock circuit, which requires the provision of double interlock for possible failure by using a mechanical protective function, and periodical checks to confirm proper operation.

### 2.2.2 Fixing of product

Mount the product on a flat and stable floor with no vibrations.

- Refer to “6.2 Outer dimensions” on page 6-2 for dimensions.

Use the foundation bolts to prevent the product from falling over.

The foundation bolts are available separately as a set.

Part number	Description	Qty.
IDF-AB501	Set of foundation bolts	1 set (4 pcs/set)

\* When using this set of foundation bolts, a large flat washer is also necessary.

- If there is not enough space around the ventilation ports of the product, loss of the original performance or failure of the product can result. Follow the conditions shown in the figure below for installation.

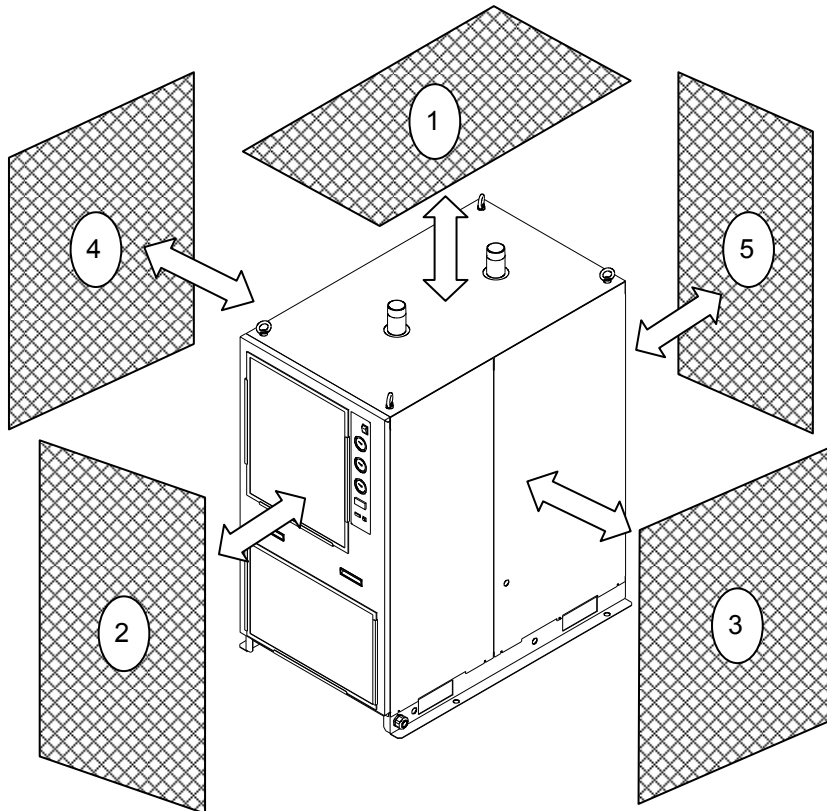

	Necessary installation space *1 and 3	Necessary maintenance space *2
1. Top	-	600mm or more
2. Front	400mm or more	600mm or more
3. Right side	-	600mm or more
4. Left side	-	600mm or more
5. Rear	400mm or more	600mm or more

\* 1 The necessary installation space is to secure the original performance of the product and conduct daily checks on the product.

\* 2 The necessary maintenance space is to conduct maintenance and repairs when the product fails. Ensure that sufficient space can be secured for repair.

\* 3 If the ventilation direction is changed, keep at least 400mm of space in that direction.

### 2.2.3 Change of ventilation direction



## Caution

- When handling the panel, wear protective gloves to prevent injuries from its sharp edges.

When the ventilation direction is to be changed, replace the panel to which ventilation should be directed with a panel prepared separately.

The figure below shows the replacement of panels when the original ventilation direction was to the rear.

E.g. IDF100F-30

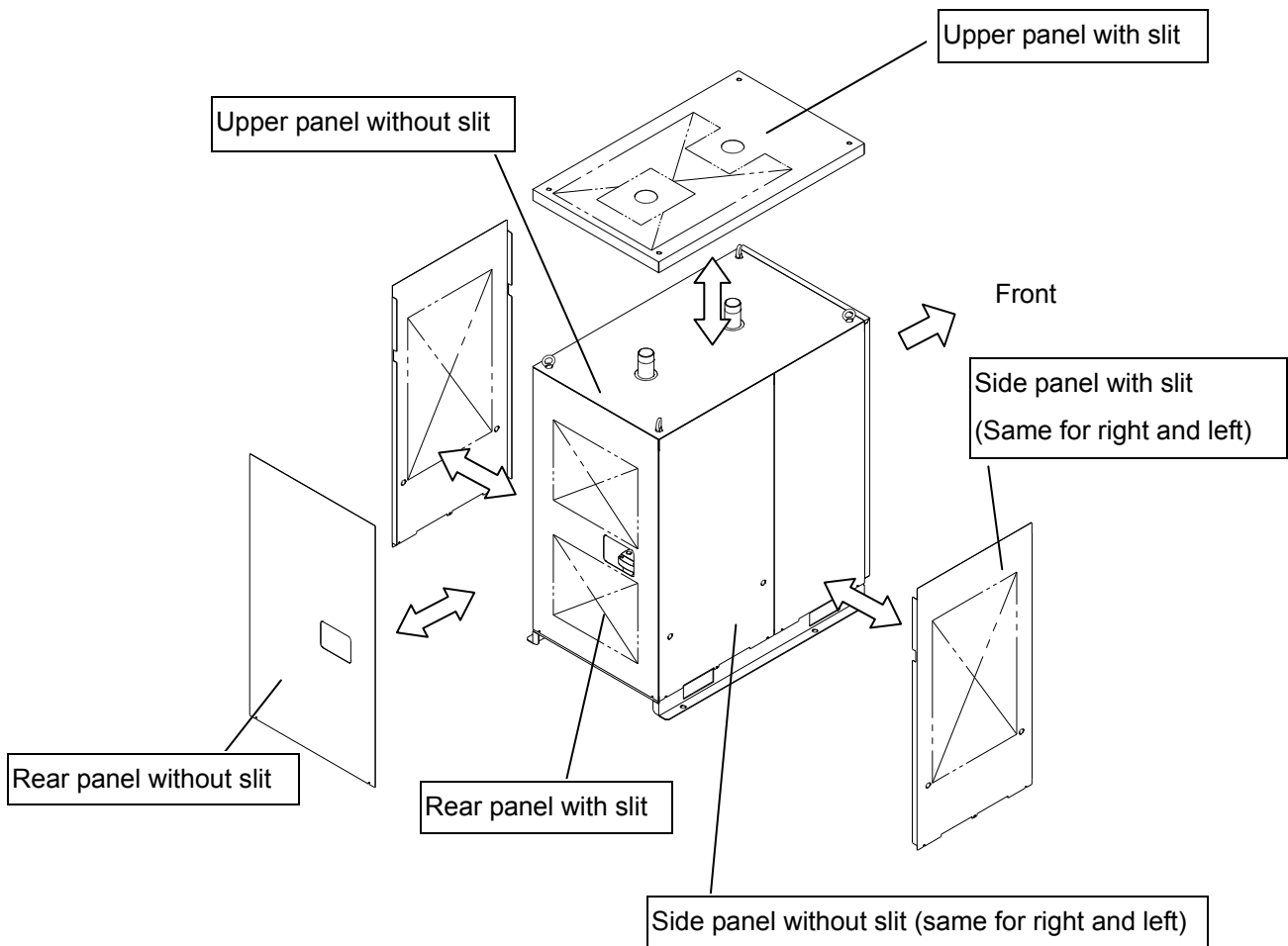

Replace the panel to which ventilation should be directed with one with slit, and the panel where ventilation was previously directed with a panel without slit. For ventilation to the top, be sure to use the product indoors.

The surface with the switch with lamp is viewed as the front.

The change from the right side to the left side can be done by swapping over the side panels.

### 2.2.4 Pneumatic piping

- Piping to the compressed air inlet and outlet should be connected with a union or flange type of fitting so that it can be removed.
- When a pneumatic fitting is connected with the body of the product, hold the pneumatic piping at the body with a pipe wrench and tighten.
- Do not apply the weight of pipes and excessive force during piping to the product.
- Be careful not to transmit vibration resulting from the compressor.
- When the compressed air inlet temperature exceeds 60°C, install an aftercooler behind the air compressor or decrease the temperature of the area where the air compressor is installed to keep it 60°C or less.
- To prevent foreign matter such as dust from getting in the supply air to the product, flush the piping before connecting. Dust or oil in the piping can cause cooling failure or other failures of the product. Install a main line filter to the compressed air source to the product.
- Use a pipe capable of withstanding the specified operating pressure and temperature and connect so that it will not have leakage.
- Be sure to install a bypass pipe to allow maintenance without stopping the air compressor.

The bypass piping should be prepared by the user.

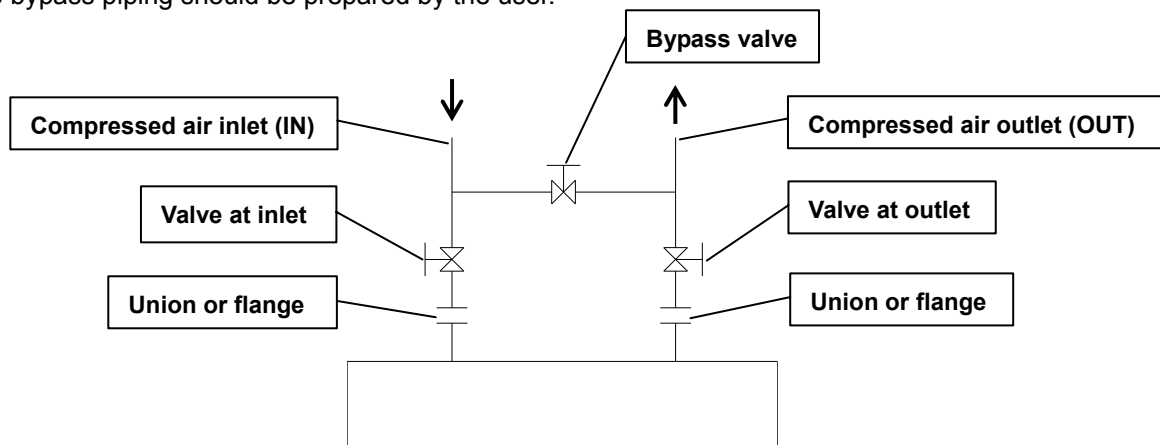

### 2.2.5 Draining piping

- The drain tube is equipped with a polyurethane tube of outside diameter 10mm. Release the draining end of the tube to atmosphere to let condensate flow into a water outlet.
- Condensate will be drained regularly using compressed air pressure. Fix the draining end of the tube firmly to prevent it from vibrating during draining.
- Ensure the drain tube does not rise up.
- Do not bend or crush the drain tube. When installing the product, take care not to place the product on the drain tube.

**⚠ Warning**

- When draining, follow the user's own procedure to keep operators safe. (E.g. Wear protective goggles, apron and gloves to prevent contact with the drained condensate.)
- When oils can enter the drained condensate, waste water treatment is necessary.

**Follow the bylaws or rules of the local municipality.**

- The drain tube is at the left side of the product, but can be taken from the right side.

1. Remove the rear panel.
2. Take out the drain tube inward.
3. Cut the rubber grommet on the opposite side using a cutter.
4. Pass the drain tube through.
5. Replace the rear panel.

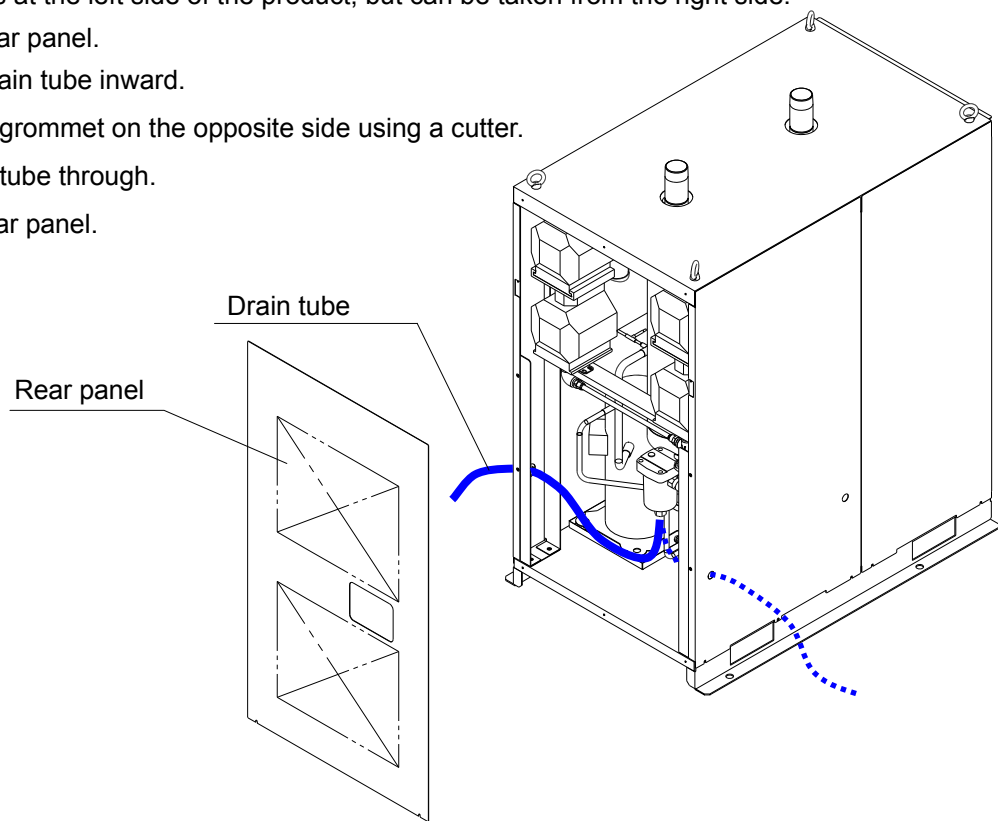

**Caution**

- When handling the rear panel, be sure to wear protective gloves to prevent injuries from its sharp edge.

### 2.2.6 Draining piping for condensed water

When the product is used in a environment with high humidity, condensation may be generated internally. The condensed water can be drained from the right side of the base of the product. Let condensate flow into a water outlet or install a drain pan, etc.

This draining piping is only for condensed water in inside drain pan.

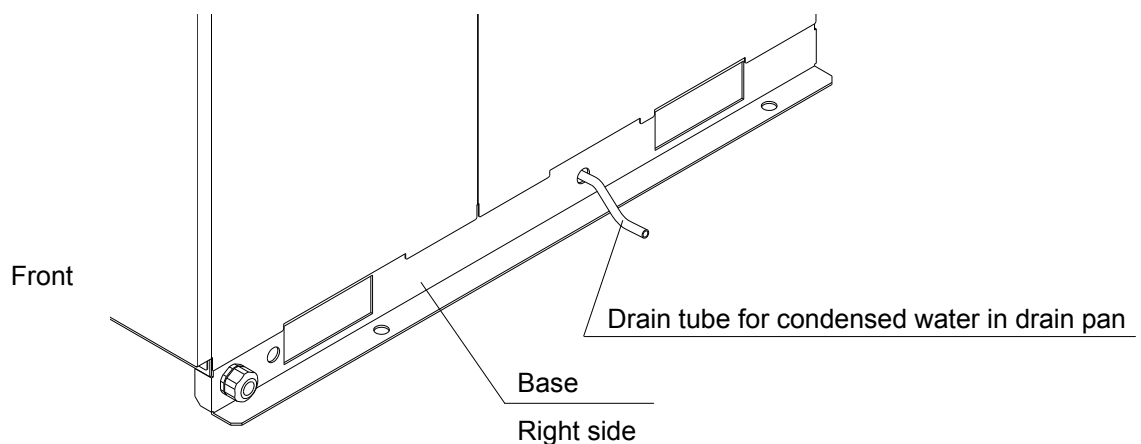

### 2.2.7 Electric wiring

#### **Warning**

Only qualified persons are allowed to wire the product.

- Before wiring, be sure to shut off the power supply. Never perform wiring work while the product is energized.
- Ensure a stable power supply with no voltage surges.
- Ensure that an ground fault circuit interrupter with appropriate capacity for ground fault and load is used in the power supply of the product to prevent electrical shock and burnout of the compressor motor. See “6-1 Specification table” for details.  
Use a power supply suitable for the specifications of the product.  
Be sure to connect the ground connection.
- Grounding should never be connected to a water line, gas line or lightning rod.
- Multiple wiring is dangerous because it may lead to heat generation and cause a fire.
- Do not modify the electrical wiring of the power supply.
- For use in Europe, install a breaker compliant with applicable IEC standards to the power supply of the product.

#### [Wiring of power supply]

- \* Be sure to install an ground fault circuit interrupter to the power supply. (To be prepared by the user.)  
[Sensitivity of leak current: 30mA or less, Rated current: 30A]

#### Specifications of power supply cable

Prepare the following power supply cable.

Power supply cable: 3.5mm<sup>2</sup>(12AWG) or larger, Cable outside diameter Approx. 14 to 18mm, 4 cores (including ground)

Approx. 0.6m is necessary to route the internal wiring of the product.

#### Power supply cable length

The power supply cable length from the product should be less than 30m.

Terminal block (refer to “1.1 Name and function of parts” for details).

Connect the power supply cable and ground to the terminal block on the right. The connection size is M4.

Be sure to use a round crimped terminal.

Applicable crimped terminal width: 9.5mm or less

- \* Option R: The power supply is connected to the inlet side of the ground fault circuit interrupter, not the terminal block.

The ground fault circuit interrupter is located inside the front panel. The connection size is M5.

Applicable crimped terminal width: 9.5mm or less

#### [Wiring procedure]

1. Remove the front panel of the product.
- \* When lifting the front panel, be sure to hold the handle.

2. Pass the power supply cable through by using the cable fixture at the right bottom base of the product, and connect it to the terminal block. (Refer to the label on the terminal block.)

M4 tightening torque: 1.4 to 2.0Nm

- \* Option R: M5 tightening torque: 2.6Nm

Fix the cable with a cable tie as shown on page 2-10.

Do not touch equipment other than the terminal block during wiring.

3. If you are not performing wiring for operation, error signal and remote control, put back the front panel.

### [Wiring for operation, error signal and remote control]

#### Specifications of signal cable

Prepare the following cable.

Cable: 0.5mm<sup>2</sup> (20AWG), Cable outside diameter: 17mm or less, 6 cores 0.5mm<sup>2</sup>

Approx. 0.9m is necessary to route the internal wiring of the product.

#### Signal cable length

The signal cable length from the product should be less than 30m.

Terminal block (refer to "1.1 Name and function of parts" for details).

Connect the signal cable to the terminal block on the left. The connection size is M3.

Applicable crimped terminal width: 6.5mm or less

#### [Wiring procedure]

1. Remove the front panel of the product.
2. Take out the signal cable from the signal cable entry at the right bottom base of the product, fix it to the steel plate at the back with a cable bushing, etc. and connect it to the terminal block.  
(Refer to the label on the terminal block.) M3 tightening torque: 0.63 to 1Nm.  
Do not touch equipment other than the terminal block during wiring.
3. Put back the front panel.

#### [Remote control]

- \* Voltage is applied to the terminal block. Be sure to turn off the switch with lamp before wiring.
- 1) Disconnect the wires from no. 5 and 6 of the terminal block and mount the external switch.
    - The external switch used for remote control should be an alternate type (no voltage dry contact).
  - 2) For remote control, with the switch with lamp turned on, turn the external switch on and then off.
    - In remote control, the product cannot be started up from the operation panel.
    - When the product is to be stopped during remote control, turn off the switch with lamp.

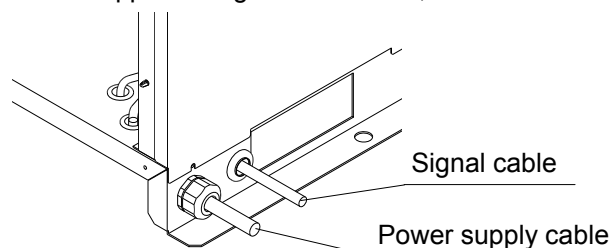

### 2.3 Reinstallation of the product

#### **Caution**

- Only people who have sufficient knowledge and experience about the product and its accessories are allowed to reinstall the product in a different location. Also, be sure to follow the instructions below.

When moving the product to a different location or reinstalling it after it has been used (including trial run), follow the whole procedure in Chapter 2 beforehand.

#### - Disconnection of power supply cable

Be sure to cut the facility power supply before disconnecting the power supply cable.

#### **Warning**

- Only people who have sufficient knowledge and experience are allowed to perform wiring.
- Before wiring, be sure to shut off the power supply. Never perform wiring work while the product is energized.

#### Removal of pneumatic piping

#### **Warning**

- Only people who have sufficient knowledge and experience are allowed to perform piping work.
- Before removing piping, be sure to shut off the air supply and the product.
- Do not remove piping with any air pressure remaining internally.

Clean off any sealant debris after the piping is removed. If any sealant debris gets into the product during reinstallation, it may lead to cooling failure or other product failures.

#### [How to release the compressed air]

1. The bypass valve needs to be opened only if compressed air is necessary while the product is removed.
2. Close the compressed air inlet valve and outlet valves.
3. Check the ball valve of the auto drain is open.
4. Press and hold the flush button at the top of the auto drain to release the internal air pressure from the product. For details, refer to maintenance of the auto drain in Chapter 4 "4.2 Parts requiring regular maintenance".

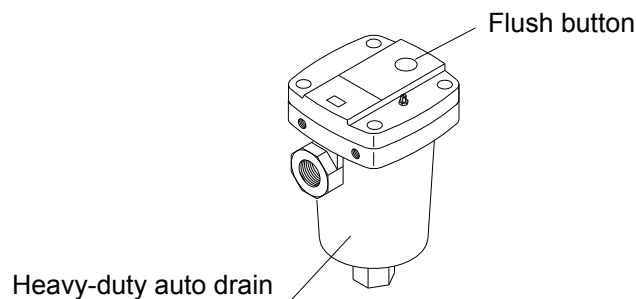

**3**

## Start and stop



### Caution

**Only people who have sufficient knowledge and experience about the product and its accessories are allowed to start and stop the product.**

### **3.1 Before Starting**

Check the following items before performing a trial run of the product.

- Installation conditions
  - Check visually that the product is installed horizontally.
  - Ensure the product is fixed firmly by the anchor bolts.
  - Do not place any heavy object on the product, or apply excessive force to the product by the external piping.
- Connection of cables
  - Check the power supply and signal cables and ground are correctly connected.
- Drain tube
  - Check proper connection of the drain tube.
- Pneumatic piping
  - Check proper connection of pneumatic piping. Ensure the valves at the inlet and outlet and bypass of the product are completely closed.
- Ball valve
  - Check the ball valve of the auto drain is open.
- Check the ground fault circuit interrupter built into the product is turned on if option R is selected.

### **3.2 Start**

Start the product by the following procedure.

- 1) Turn on the main power supply. Then, turn on the switch with lamp.  
For remote control, turn on the external switch as well.
- 2) The lamp will light up and the condenser cooling fan will start turning a while later, and hot air will blow out from the exhaust port.
- 3) Open the valve at the inlet of the product slowly and fully. Ensure the bypass valve is completely closed. Check there is no air leakage.
- 4) After the pneumatic pressure gauge reaches the specified pressure of the air compressor, open the valve at the outlet slowly and fully.
- 5) The condenser cooling fan keeps starting and stopping depending on the compressed air and ambient temperature conditions, but the compressor keeps operating continuously, and the evaporation thermometer stays within the green area. If the evaporation thermometer exceeds the green area (indicates a higher temperature), refer to "Chapter 5 Troubleshooting".
- 6) A while after the compressed air starts being supplied, the drain tube will drain condensate automatically.
- 7) Keep operation in that condition.



## Caution

- Frequently turning on and off the switch can cause failure.
- Since the auto drain of the product is designed in such a way that the valve closes at 0.05MPa or higher (N.C. type), air will blow out from the drain port when the pressure increases. Therefore, if the air compressor has a small air delivery, the pressure may not be sufficient.

### **3.3 Stop**

- 1) Turn off the switch with lamp.  
For remote control, turn off the external switch as well.
- 2) The lamp will go off and operation will stop.

### **3.4 Precautions for restarting operation**

- Allow at least 3 minutes before restarting the product. If the product is restarted within 3 minutes after being stopped, the protection circuit will be activated, operating light will turn off and the dryer will not be activated.  
If operation cannot be restarted, refer to “Chapter 5 Troubleshooting” to solve it.

### **3.5 Check items after starting**

Check the following items when starting the product. Immediately stop the operation in the event of failure. Turn off the switch with lamp and shut off the breaker of the main power supply.

- There is no compressed air leakage.
- The pressure, temperature, flow rate and ambient temperature of the compressed air are within the specified range.
- Condensate is coming out from the drain tube.
- The evaporation thermometer is in the green area.
- There is no abnormal sound, vibration or odor from the product.

### 3.6 Display of controller

- Check the controller of the product to find out the condition of the protective equipment.

<span style="font-size: 1.2em; font-weight: bold; margin-left: 10px;">Caution</span>
<p><b>* Beware of electrical shock when the front panel of the product is removed. Do not touch the terminals.</b></p>

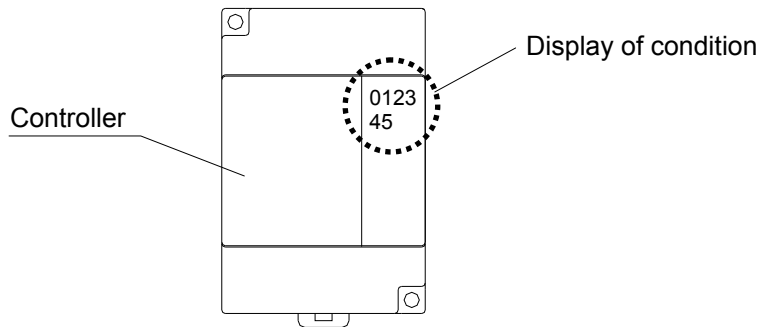

Display	Content	Condition		Protective equipment
		On	Normal	
0	Phase reverse relay	On	Normal	Automatic reset type
		Off	The power supply is incorrectly connected or interrupted.	
1	Compressor thermal relay	On	Normal	Manual reset type
		Off	Over current is flowing to the compressor.	
2	Fan motor thermostat	On	Normal	Automatic reset type
		Off	The fan motor is overheated.	
3	Refrigerant pressure switch	On	Normal	High pressure/Manual reset type Low pressure/Automatic reset type
		Off	The refrigerant pressure has abnormally increased or decreased.	
4	Remote control signal	On	The remote control signal is received.	/
		Off	The remote control signal is not received.	

When the protective equipment operates, the product will stop operation. In that case, refer to Chapter 5 and eliminate the cause of stopping before restarting.

The automatic reset type protective equipment can be reset by turning off the switch with lamp. The manual reset type protective equipment can be reset individually by turning off the switch with lamp and in accordance with the procedure shown in 5.2.

<span style="font-size: 1.2em; font-weight: bold; margin-left: 10px;">Caution</span>
<p><b>Allow at least 3 minutes before restarting the product. If the product is restarted within 3 minutes, it can fail to start, or it may start and then stop again.</b></p>

### **3.7 Signal output**

- The operation signal and error signal are output with dry contact.

	Signal output
1. START signal	- At start: Closed - At stop: Open (Including FAULT error): Open
2. FAULT signal	- Protective equipment in operation: Closed - Protective equipment not in operation: Open

- \* If the product is stopped by the overload relay built into the compressor, the FAULT signal will not be output.

- Contact capacity

Resistance load 2A, Inductive load 80VA, Lamp load 100W

Minimum load: DC5V, 2mA



# 4 Checks and inspection

### 4.1 Daily check

Check the following items daily. Immediately stop the operation in the event of failure, and refer to “Chapter 5 Troubleshooting” to solve it.

- There is no compressed air leakage.
- The START lamp lights up during operation.
- Condensate comes out of the drain tube during operation.
- The evaporation thermometer is in the green area during operation with the compressed air supplied.
- The evaporation thermometer indicates a temperature approx. 3 to 10°C lower than the ambient temperature when operation is stopped and no compressed air supplied.
- There is no abnormal sound or vibration.
- There is no abnormal odor or smoke.
- The filter cleaning lamp is off.
- The running time accumulator display is not flashing or off.

### 4.2 Parts requiring regular maintenance

#### 4.2.1 Cleaning of filter at ventilation port (suction port)

To eliminate dust at the ventilation port (suction port), apply an electrical vacuum or air blow once every month. If the filter gets dirty, the evaporation thermometer will exceed the green area. Wear protective goggles and a mask to prevent dust from entering the eyes or throat during air blow.

The product is equipped with a lamp to indicate when it is time for cleaning. When the running time exceeds 300 hours, the lamp will light up. Use this as a guideline for when to clean the filter. To turn off the lamp, press the reset switch. It will light up again 300 hours after the reset switch is pressed.

If the evaporation temperature exceeds the green area due to heavy dirt before the lamp lights up, shorten the time to the next cleaning.

#### 4.2.2 Maintenance of auto drain

	<b>Danger</b>
<p>- Do not remove the auto drain with the air pressure remaining internally. If the compressed air is left in the product, when some part is loosened, it may cause sudden lurching or other unexpected accidents.</p> <p>- When removing the panel, wear protective gloves to prevent injuries.</p>	

	<b>Danger</b>
<p>Do not remove the auto drain while operating the product. There are parts that get hot and the power supply is at a high voltage during operation. Burns by heat and electrical shock by high voltage can result.</p>	



### Danger

There is still a danger of burns due to residual heat of internal parts even after the product is stopped. Do not perform replacement until the temperature of parts falls below 50°C. As a guide, this takes approx. 10 to 15 minutes.



### Danger

There is a risk of touching drained waste liquid during replacement.  
When draining, follow the user's own procedure to keep operators safe. (E.g. Wear protective goggles, apron and gloves to prevent contact with the drained condensate.)



### Danger

Use an aqueous solution of neutral detergent for cleaning. Do not use solvents like thinner.



### Warning

When oils can enter the drained condensate, waste water treatment is necessary. Follow the bylaws or rules of the local municipality for disposal.



### Warning

Be sure to check air pressure is zero before replacing the element or performing the maintenance of the auto drain.

As a preventive maintenance, press the flush button of the heavy-duty auto drain regularly to clean the discharge valve (for flushing).

If operation failure occurs due to heavy dirt after the flushing, disassemble the auto drain and clean inside. Also, shorten the time to the next flushing timing.

The pilot exhaust of the heavy-duty auto drain is at the position shown in the figure. **Do not close the exhaust port.** Also, clean the exhaust port to prevent it from getting blocked by dust.

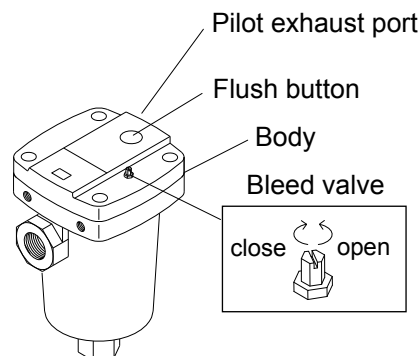

[Disassembly and cleaning of auto drain]

- Turn off the STOP switch.
  - Fully open the valve for pneumatic piping. The bypass valve needs to be opened during this work when the compressed air is necessary.
1. Remove the rear panel and check the ball valve is closed.
  2. Press the flush button and release the internal air pressure of the auto drain.
  3. Remove the 4 hexagon socket head bolts using a hexagon wrench key with nominal size 5, and lift up the body. The whole draining mechanism can be taken out.
  4. Hold the body and immerse the lower part from the body (draining mechanism) into water or tepid water solution of neutral detergent, and remove dirt.

**Caution Do not use liquids other than neutral detergent for cleaning.**  
**Also, never disassemble the draining mechanism.**  
**In the worst case, it will be impossible to reuse it.**

When the main valve (drain port) is damaged or too dirty to be cleaned, the whole draining part needs to be replaced.

5. Wipe the internal surface of the housing with a cloth.  
 If there is dust stuck to the inside of the housing, leakage can occur after reassembly.

\* If the O ring gets dirty, wipe its surface with a soft cloth, and check there are no flaws and deformation. If any flaw or deformation is found, they can cause leakage after reassembly, and so the O-ring should be replaced.

6. Mount the O-ring in the groove on the top of the housing. Take care not to let the O-ring protrude.
7. Hold the body with the draining mechanism at the bottom, and mount it to the housing in the direction where the flush button comes to the opposite side of the inlet of condensate. (If there is a gap of approx. 3mm between the body and housing when this is done, the drain mechanism may not be inserted fully. Turn it to the right and left slightly.)
8. In the condition of step 7, tighten the 4 hexagon socket head bolts.

Appropriate tightening torque: 5Nm

**Caution Tighten the bolts without a gap between the body and housing.**  
**If they are forcibly tightened with the gap remaining, the parts can be damaged.**

9. After reassembly is completed, open the valve at the inlet of condensate slowly, and check there is no leakage before using.

\* If operation failure occurs even after disassembly and cleaning, replace the whole draining mechanism.  
 And, shorten the time to the next cleaning timing.

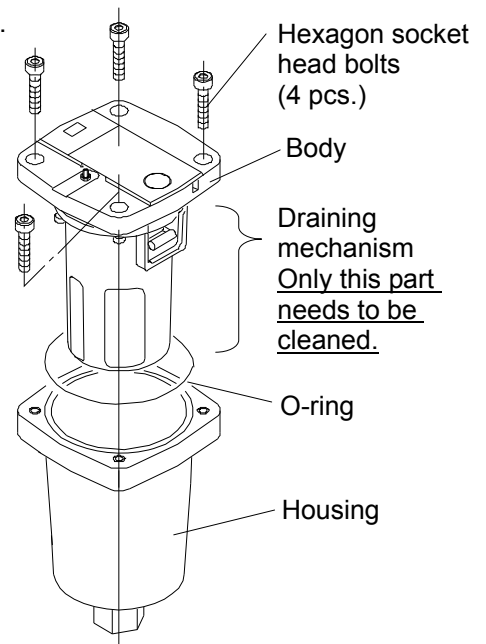

Part number	Description	Qty.
ADH-E400	Draining mechanism replacement kit	1

### 4.2.3 Maintenance of timer type solenoid valve with auto drain (Option V)

As a preventive maintenance, clean the built-in strainer regularly.

[Cleaning of built-in strainer]

- Do not turn off the STOP switch. (Electricity is used.)
  - Fully open the valve for pneumatic piping.
  - The bypass valve needs to be opened during this work when the compressed air is necessary.
1. Remove the rear panel and check the ball valve is closed.
  2. Press the flush button and then the test switch to release the internal air pressure of the auto drain.
  3. Remove the strainer cap and take out the built-in strainer and clean.
  4. Put back the built-in strainer and its cap and open the valve at the inlet of condensate, and check there is no leakage before using.

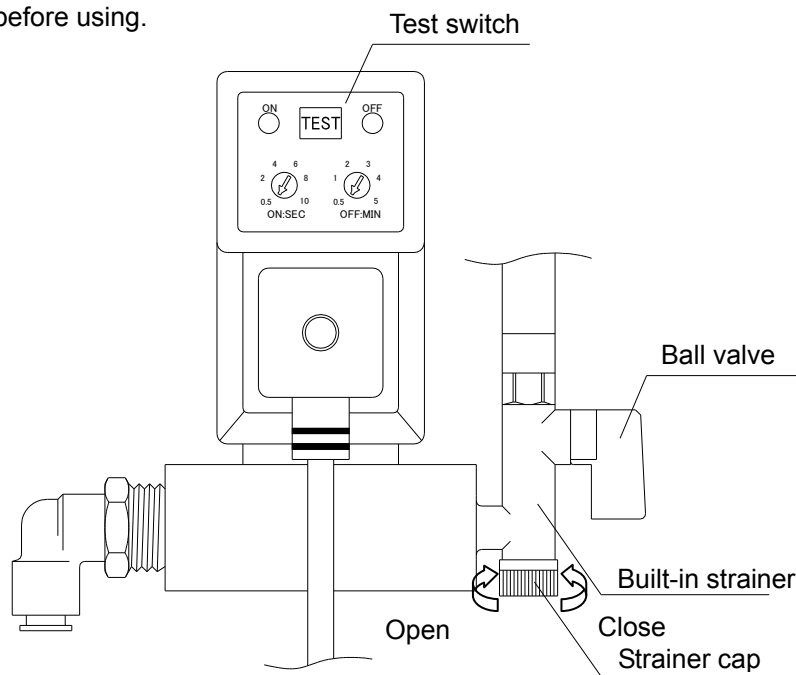

### 4.2.4 Maintenance of operating time accumulator

The operating time accumulator uses a lithium battery. The referential life of the battery is 7 years (at 25°C). This life is not guaranteed.

If the display is flashing or off, the battery has reached the end of its life, and needs to be replaced.

Part number	Description	Qty.
IDF-KY92S-36	Replacement battery for operating time accumulator	1

The replacement of the battery will reset the display to zero. It is useful to record the time displayed before the replacement.

[MEMO]

Date	Running time display (h)	Accumulated time (h)



## Warning

The product uses a lithium battery.

Do not short-circuit the positive and negative sides of the battery, charge, disassemble, press and deform or throw the battery into a fire.

The battery can burst or cause a fire or liquid leakage.

[Battery replacement procedure]

1. Turn off the power supply.
2. Remove the front panel.

Remove and turn over the operation display panel.

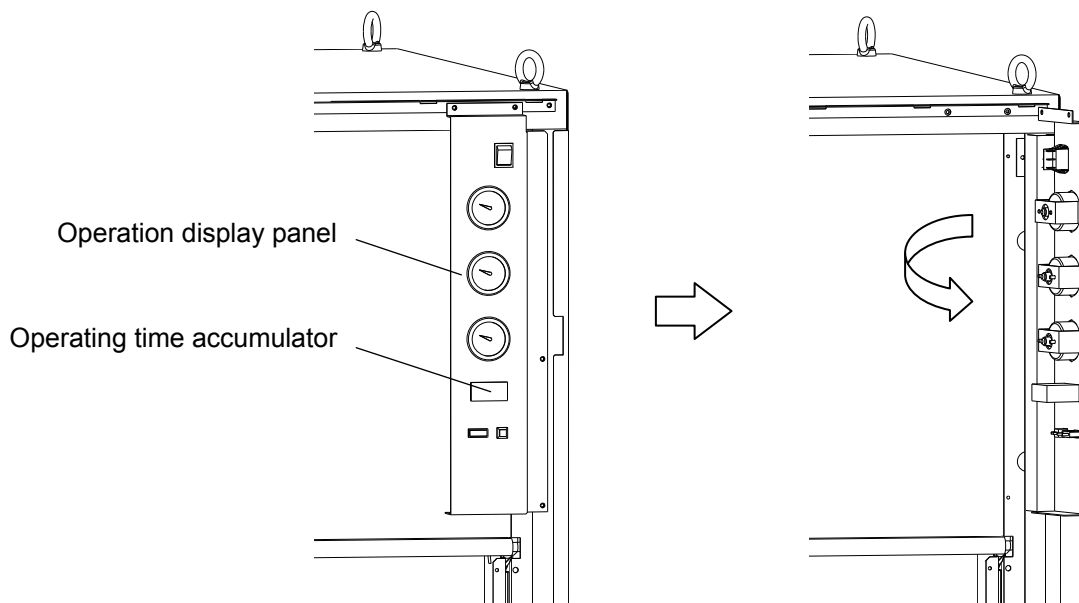

3. Disengage the hooks on the top and bottom of the case with a tool.

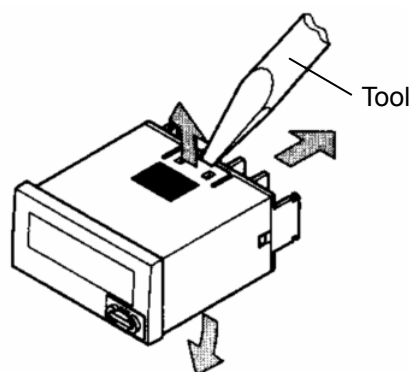

4. Pull out the body from the case.

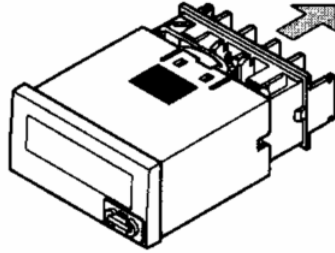

5. Lift up the end of the battery and remove.  
When removing the battery, do not touch the display and parts.

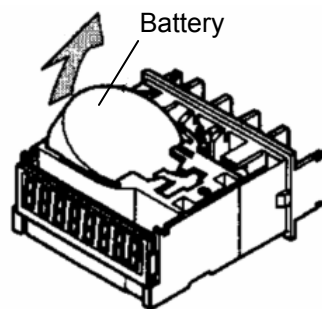

6. Before inserting the battery, wipe off its surface for cleaning.
7. Connect the positive and negative sides of the battery correctly.
8. After the replacement of the battery, put the body back into the case.  
Check the hook of the case is engaged correctly.

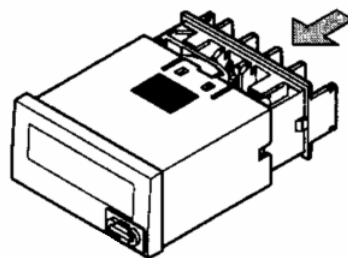

9. Short the terminals 3 and 4 before using and check the display shows zero.
10. Put them back as they were.

**5**

# Troubleshooting

## 5.1 Troubleshooting

If any error is found in the product, investigate the following points. If the error cannot be solved, turn off the power supply and contact your local supplier or SMC sales representative.

Trouble	Possible cause	Remedy
Although the switch with lamp is turned on, the lamp does not light up and the product does not start operating.	The power supply cable has been loosened or disconnected.	- Reconnect it firmly.
	The ground fault circuit interrupter is not turned on.	Check the capacity of the ground fault circuit interrupter. - Check the product was not restarted within 3 minutes after being stopped. - Turn on the ground fault circuit interrupter and try to operate. If the ground fault circuit interrupter turns back off, the insulation failure of the product is suspected. Turn off the power supply and contact SMC. [Ground fault circuit interrupter (Option R)] - The ground fault circuit interrupter is turned off at the time of shipment. Turn on it before starting operation. - Operation cannot be recovered automatically by turning on the ground fault circuit interrupter. Be sure to eliminate the cause before turning it on. Restarting without solving the cause can cause a serious accident.
	The 3-phase power supply is connected incorrectly.	- Swap over the connection of 2 of the 3 wires (R and T phases).
	The external switch for remote control is not turned on.	- Turn on the external switch.
The lamp goes off and the compressor for refrigeration stops.	The wiring for remote control has been loosened or disconnected.	- Reconnect it firmly.
	The product is installed in an inappropriate location. Ambient temperature is excessive.	- Improve ventilation condition and reduce the ambient temperature as much as possible. - Refer to "5.2 Reset of protective equipment" and reset the protective circuit.
	The ventilation port is obstructed by a wall or clogged with dust.	- Keep the product 40cm or more away from the surrounding walls. - Clean the ventilation ports once every month. - Refer to "5.2 Reset of protective equipment" and reset the protective circuit.
	The compressed air temperature is too high.	- Improve the ventilation in the location where the air compressor is installed, or decrease the ambient temperature to allow the discharge air temperature of the air compressor to go down. - Install an aftercooler after the air compressor to reduce the temperature. - Refer to "5.2 Reset of protective equipment" and reset the protective circuit.
	The fluctuation of the power supply voltage is too large.	- Install a power supply transformer or use a different power supply to provide appropriate voltage. - The fluctuation of the power supply voltage should be kept within +/-10% of the rated voltage. - Refer to "5.2 Reset of protective equipment" and reset the protective circuit.

Trouble	Possible cause	Remedy
The evaporation thermometer is over the green area without hot air coming from the ventilation port (exhaust port). (The compressor for refrigeration has stopped with the lamp lit up.	The product is installed in an inappropriate location. Ambient temperature is excessive.	- Improve ventilation condition and reduce the ambient temperature as much as possible.
	The ventilation port is obstructed by a wall or clogged with dust.	- Keep the product 40cm or more away from the surrounding walls. - Clean the ventilation ports once every month.
	The compressed air temperature is excessive.	- Improve the ventilation in the location where the air compressor is installed, or decrease the ambient temperature to allow the discharge air temperature of the air compressor to go down. - Install an aftercooler after the air compressor to reduce the temperature.
	The fluctuation of the power supply voltage is too large.	- Install a power supply transformer or use a different power supply to provide appropriate voltage. - The fluctuation of the power supply voltage should be kept within +/-10% of the rated voltage.
The built-in overload relay of the compressor for refrigeration has started.		- Check the product was not restarted within 3 minutes after being stopped.
The evaporation thermometer is over the green area with hot air coming from the ventilation port (exhaust port).	The product is installed in an inappropriate location. Ambient temperature is excessive.	- Improve ventilation condition and reduce the ambient temperature as much as possible.
	The ventilation port is obstructed by a wall or clogged with dust.	- Keep the product 40cm or more away from the surrounding walls. - Clean the ventilation ports once every month.
	The compressed air temperature is excessive.	- Improve the ventilation in the location where the air compressor is installed, or decrease the ambient temperature to allow the discharge air temperature of the air compressor to go down. - Install an aftercooler after the air compressor to reduce the temperature.
Moisture is generated at the downstream of the compressed air line.	The bypass valve is open.	- Be sure to fully close the bypass valve.
	Condensate is not drained from the auto drain.	- Check the draining piping is not used in an upward direction nor bent. - Check the auto drain. - Check the ball valve is open.
	The piping of a different system without an air dryer joins the piping after the product.	- Install another air dryer (this product) in that system. - Keep the two systems separate.
The compressed air pressure is too large.	The valves at the inlet and outlet of the piping of the product are not fully opened.	- Be sure to fully open the valves at the inlet and outlet of the product.
	The air filter, etc. installed in the compressed air piping has got clogged.	- Replace the element of the air filter. (Follow the Operation Manual of the equipment.)
The operating time accumulator display is flashing or off.	The built-in battery has reached the end of its life.	- Refer to "4.2.2 Maintenance of operating time accumulator" and replace the battery.

## 5.2 Reset of protective equipment

While the product is stopped, the protective equipment in the refrigerating circuit is operating, and needs to be reset manually. Refer to page 1.3 for the positions of protective equipment.

Refer to “5.1 Troubleshooting” and eliminate the cause that triggered the protective equipment.

[Controller]

The controller can be used to find out which protective equipment has been triggered.

Remove the front panel with the switch with lamp on, and check the controller.

(Refer to “3.6 Display of controller” for details.)

### Reset of thermal relay

1. Turn off the switch with lamp.
2. Remove the front panel. The terminal block for the power supply has the thermal relay as shown in the figure on the right.
3. Check the operation indicator window of the thermal relay does not show green.
4. Press the reset button (blue). Check the operation indicator window is showing green.
5. Put back the front panel.
6. Turn on the switch with lamp to restart operation.

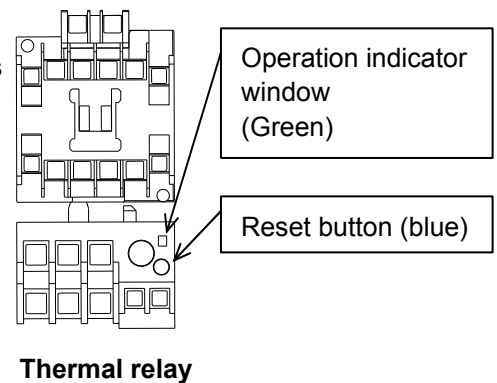

### Reset of high pressure switch

1. Turn off the switch with lamp of the product.
2. Remove the front panel. The high pressure switch is located on the left of the electric control bracket.
3. Press the red reset button.
4. Put back the front panel.
5. Turn on the switch with lamp to restart operation.

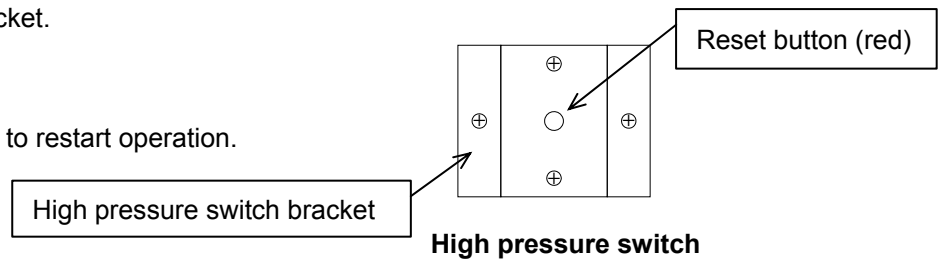

### **5.3 Reset of ground fault circuit interrupter (Option R)**

When the ground fault circuit interrupter is triggered, all lamps will go off.

Eliminate the cause that triggered the ground fault circuit interrupter (ground fault, over current, etc.).

The ground fault display button (white) has popped up → Ground fault

The ground fault display button (white) remains pressed → Over current

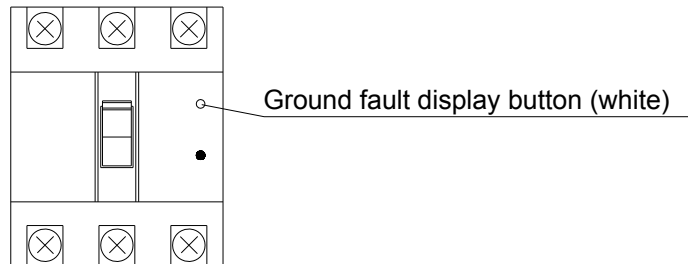

1. Turn off the switch with lamp of the product.
2. Remove the front panel.
3. Bring the lever of the ground fault circuit interrupter down to the OFF position.
4. Lift up the lever from the OFF position to the ON position.
5. Put back the front panel.
6. Turn on the switch with lamp to restart operation.

6

## Reference

### 6.1 Specification table

Item		Model	IDF100F-30	IDF125F-30	IDF150F-30	
Operating range	Fluid		Compressed air			
	Inlet air temperature	°C	5 to 60			
	Inlet air pressure	MPa	0.15 to 1.0 / 0.15 to 1.6 for option K			
	Ambient temperature (humidity)	°C	2 to 45 (Relative humidity 85% or less)			
Rated <small>Note 3)</small>	Air flow capacity m <sup>3</sup> /min	Standard conditions (ANR) <small>Note 1)</small>	50Hz	16	20.1	25
			60Hz	18.8	23.7	30
		Air compressor suction condition <small>Note 2)</small>	50Hz	16.7	20.9	26
			60Hz	19.6	24.7	31.2
	Inlet air pressure	MPa	0.7			
	Inlet air temperature	°C	40			
	Ambient temperature	°C	32			
	Outlet dew point	°C	10			
	Exhaust heat amount of unit (50/60Hz)	kW	8.0 / 9.0	10.0 / 11.5	12.0 / 15.0	
Electric specifications	Power supply voltage (frequency)		3 phase AC200V (50Hz) / AC200,220V (60Hz)			
	Power consumption (50/60Hz) <small>Note 4)</small>		kW	2.9 / 3.5	4.0 / 4.7	4.0 / 4.8
	Running current (50/60Hz)		A	10.5 / 11.5	15.4 / 15.6	15.7 / 16.0
Applicable ground fault circuit interrupter capacity (Sensitivity current: 30mA) <small>Note 5)</small>		A	30			
Refrigerant			R407C (HFC)			
Auto drain			Float type (N.O) Timer controlled auto drain for option V			
Port size			R2	JIS Flange 65A 10K	JIS Flange 80A 10K	
			(For Option K : 16K)			
Weight		kg	245	270	350	
Coating color			Panel: Urban white 1 / Base: Urban gray 2			
Applicable air compressor (screw type) output (referential)		kW	100	125	150	

Note 1) Air flow capacity under the standard condition (ANR) [20°C atmospheric pressure and 65% relative humidity].

Note 2) Air flow capacity calculated for atmospheric condition [32°C, atmospheric pressure]

Note 3) For specifications other than the rated specifications, select the model referring to the selection method.

Note 4) The value shown in it is a reference value at rated condition and is not the guaranteed value.

Note 5) Ground fault circuit interrupter is not mounted in product other than option "R".

## 6.2 Outer dimensions

[IDF100F-30- ]

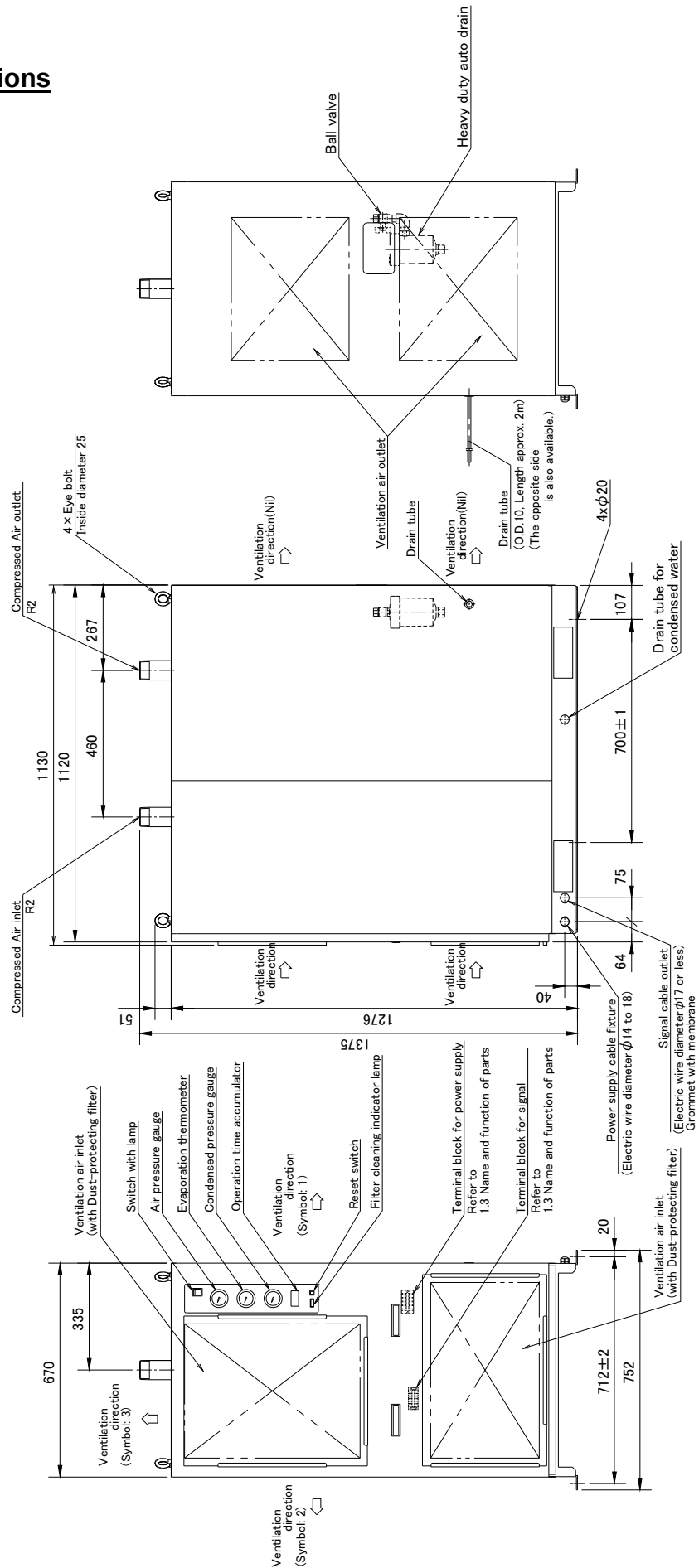

[IDF125F-30- ]

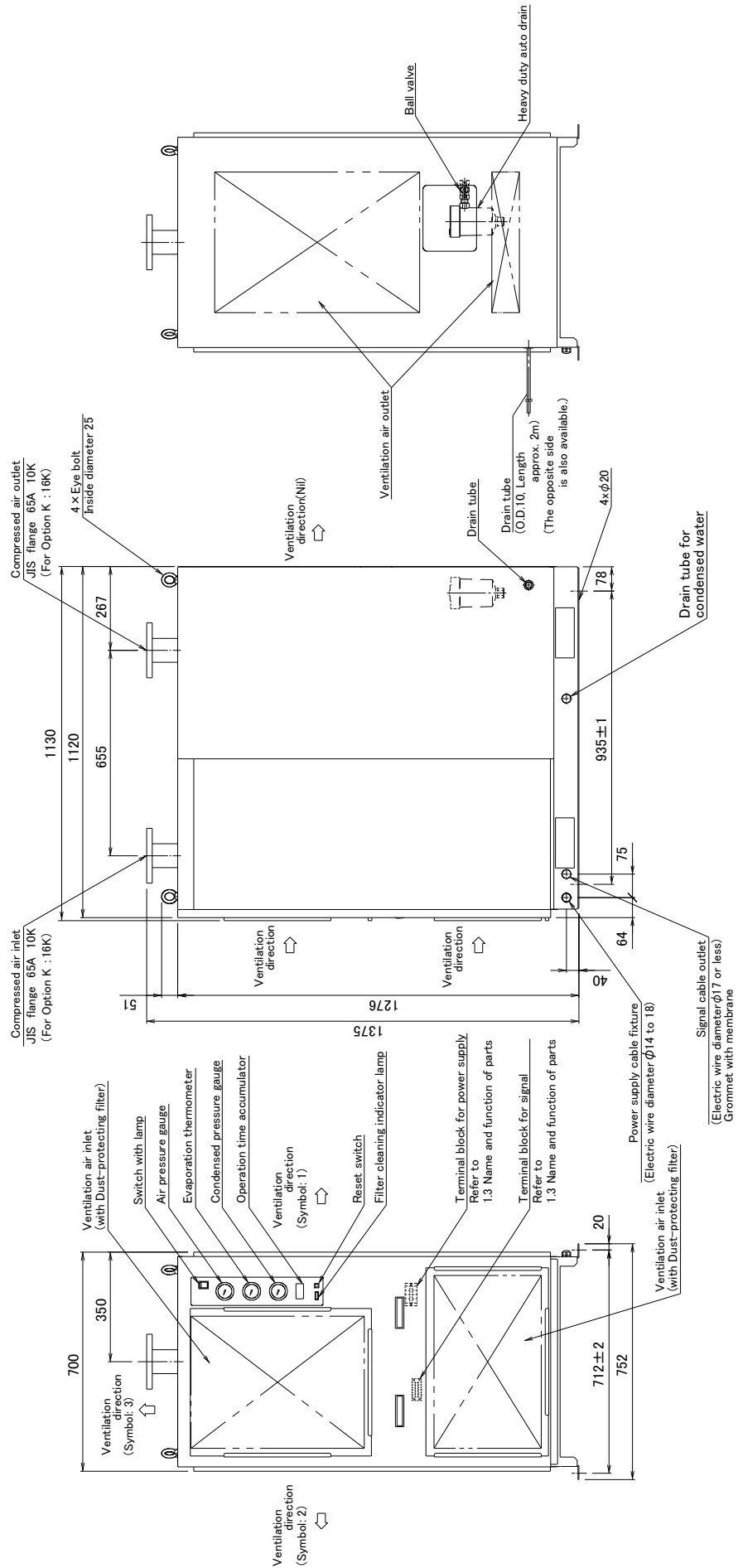

[IDF150F-30- ]

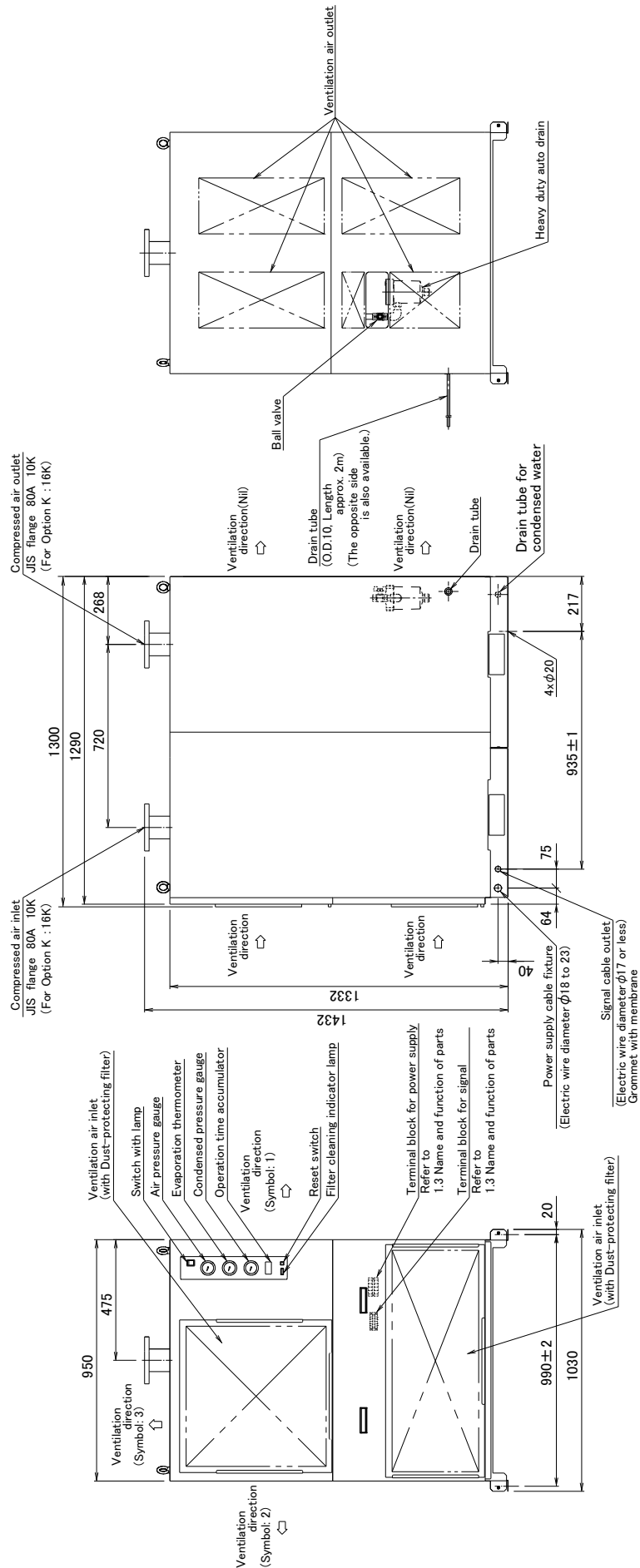

### 6.3 Electric wiring diagram

[IDF100F/125F-30- ]

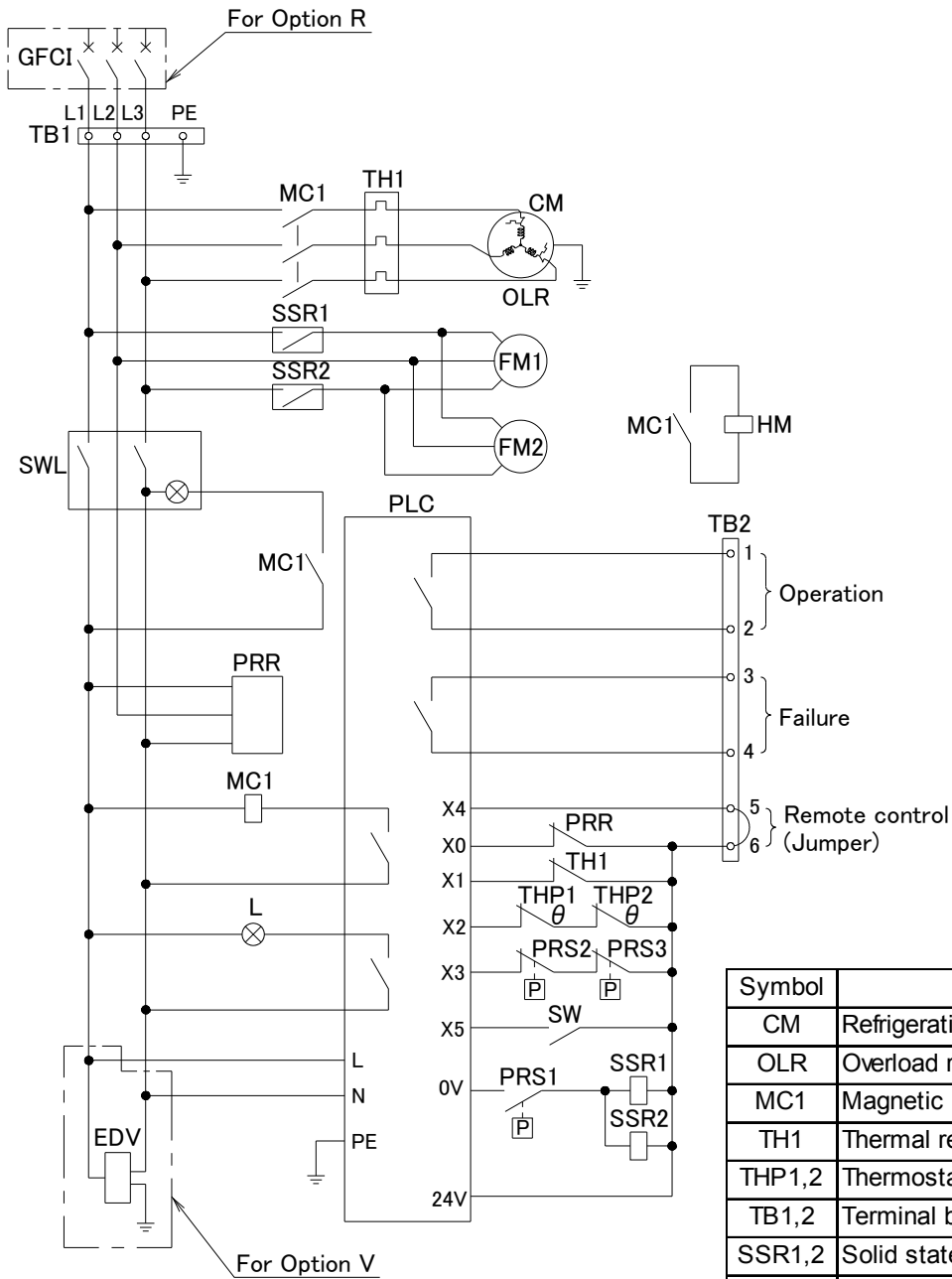

Symbol	Description
CM	Refrigerating compressor
OLR	Overload relay
MC1	Magnetic contactor
TH1	Thermal relay
THP1,2	Thermostat for Fan motor
TB1,2	Terminal block
SSR1,2	Solid state relay
FM1,2	Fan motor
SWL	Switch with lamp
SW	Lamp reset switch
L	Filter cleaning lamp
PRR	Phase reversal relay
PRS1	Pressure switch
PRS2	High pressure switch
PRS3	Low pressure switch
PLC	Programmable controller
HM	Operation time accumulator
GFCI	Ground fault circuit interrupter
EDV	Electronic drain valve

[IDF150F-30- ]

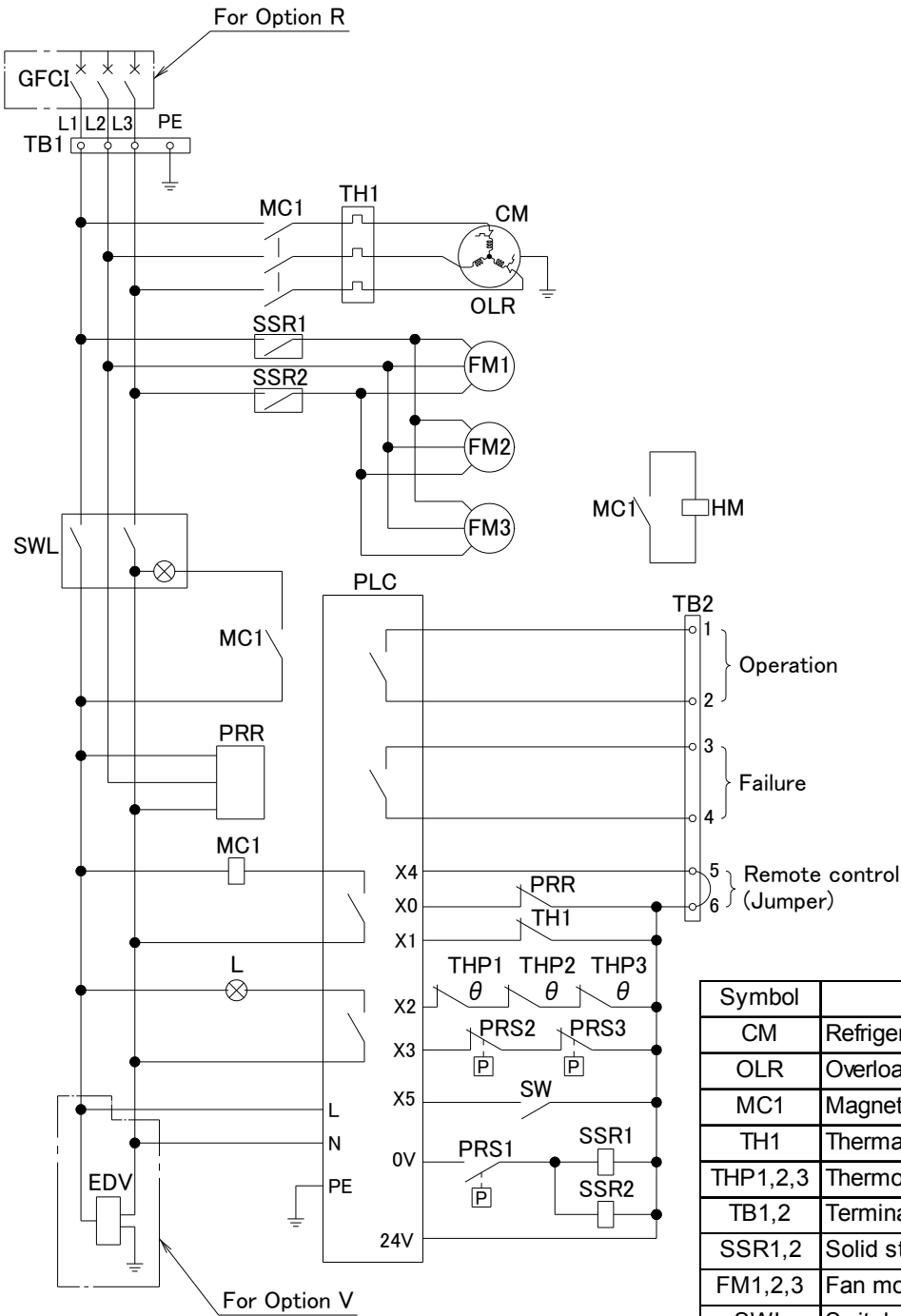

Symbol	Description
CM	Refrigerating compressor
OLR	Overload relay
MC1	Magnetic contactor
TH1	Thermal relay
THP1,2,3	Thermostat for Fan motor
TB1,2	Terminal block
SSR1,2	Solid state relay
FM1,2,3	Fan motor
SWL	Switch with lamp
SW	Lamp reset switch
L	Filter cleaning lamp
PRR	Phase reversal relay
PRS1	Pressure switch
PRS2	High pressure switch
PRS3	Low pressure switch
PLC	Programmable controller
HM	Operation time accumulator
GFCI	Ground fault circuit interrupter
EDV	Electronic drain valve

## 6.4 Pneumatic and refrigerant circuits and their functions

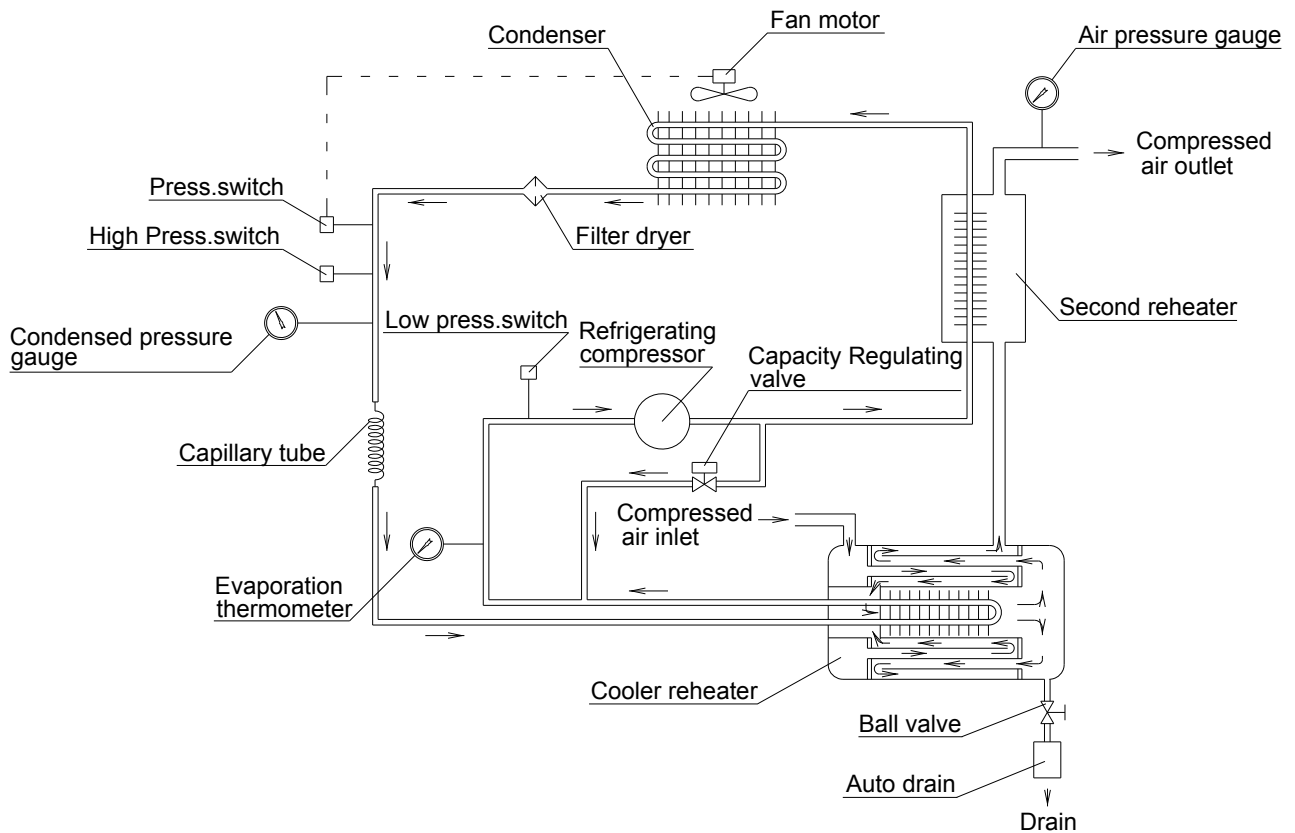

### Pneumatic circuit

The humid hot air that enters the air dryer first goes into the reheater, and exchanges its heat with dehumidified cold air to pre-cool it. Then, the air enters the evaporator, where it releases its heat to a cold HFC, and is dehumidified and cooled further to let moisture separate. After that, the air exchanges its heat with hot air that enters the air dryer at the reheater, and is heated and its temperature increases. Finally, the air is further heated at the reheater and its temperature increases higher, and it leaves the air dryer as warm, dry air.

### Refrigerant circuit

The HFC gas contained in the refrigerant circuit is compressed by the compressor, and cooled and liquefied by the condenser. When passing through the capillary tube, the HFC gas is regulated and its temperature decreases. While passing through the cooler part, it evaporates rapidly, taking the heat from the compressed air, and is sucked in by the compressor. The capacity regulating valve opens when the compressed air has been cooled sufficiently, and prevents condensed water from being frozen by excessive cooling.

### 6.5. Consumable parts and regular maintenance parts

(Note: "Qty./pc." is the quantity used per product.)

- Consumable parts (condition to be checked regularly and replaced)

Check the following parts regularly, and replace based on the referential timing.

Part number	Description	Qty./pc.	Frequency	Referential timing
IDF-FL219	Dustproof filter set (for IDF100F, 125F)	1	Every month	When it is damaged. When dirt cannot be cleaned off.
IDF-FL220	Dustproof filter set (for IDF150F)	1	Every month	When it is damaged. When dirt cannot be cleaned off.
ADH-E400	Draining mechanism replacement kit (excluding option V)	1	Every month	When it is damaged. When dirt cannot be cleaned off.
IDF-KY92S-36	Replacement battery for operating time accumulator	1	Every month	When the display is flashing or off.

- Regular maintenance parts (major parts requiring replacement depending on operating conditions)

Check the following parts regularly, and replace based on the referential timing.

Part number	Description	Qty./pc.	Replacement method	Standard replacement period*
IDF-KZR40K3E-TF5-522	Refrigerating compressor (for IDF100F)	1	B	20,000 hours (6 years)
IDF-KZR54KCE-TF5-522	Refrigerating compressor (for IDF125F, 150F)	1	B	20,000 hours (6 years)
IDF-KFTB-Z385	High pressure switch	1	B	20,000 hours (6 years)
IDF-KACB-4UA15	Low pressure switch	1	B	20,000 hours (6 years)
IDF-KACB-1UA08	Pressure switch	1	A	20,000 hours (6 years)
IDF-4096016	Magnetic contactor (for IDF100F)	1	A	20,000 hours (6 years)
IDF-4096017	Magnetic contactor (for IDF125F, 150F)	1	A	20,000 hours (6 years)
IDF-KUC4-153BP	Fan motor	2 (Only IDF150F: 3)	A	20,000 hours (6 years)
IDF-KFX1S-10MR-ES/UL	Programmable controllers	1	A	20,000 hours (6 years)
IDF-KLLK45-L3UL-CSA-TUV	Switch with lamp	1	A	20,000 hours (6 years)

\* The operating time (hours/ years) stated above depends on the operating conditions (ambient temperature, installation environment, etc.), and is not guaranteed.

The number of years stated is a reference value for a running rate of 12 hours per day (JEMA) x 300 days. Also, the replacement period is the time over which the probability of the failure of the product will increase. Replacement will not necessarily be required, but should be done if any error is found or as a preventive maintenance measure.

#### - Replacement procedure

A: Only people who have knowledge and experience of piping and electricity are allowed to replace parts.

(If there is no such person, contact SMC or a specialized vendor.)

B: Before replacement, the recovery of refrigerant is necessary. Also, since replacement requires expertise, contact SMC or a specialized vendor.