



Operation Manual

PRODUCT NAME

Magnet Gripper

MODEL / Series / Product Number

MHM-16D*

MHM-25D*

MHM-32D*

MHM-50D*

SMC Corporation

Contents

Product outline

Attracts and holds heavy objects with a magnet

Transfers steel plates without a vacuum

Holding force (Attraction force) can be adjusted.

Safety Instructions

1. Specifications

2. Installation

2-1 Design

2-2 Mounting

2-3 Environment

2-4 Air supply

2-5 Piping

2-6 Lubrication

2-7 Auto Switch Mounting

2-8 Other

3. Adjustment

4. How to order

5. Maintenance

5-1 Maintenance or inspection

5-2 replacement part

5-3 Maintenance



Safety Instructions

These safety instructions are intended to prevent hazardous situations and/or equipment damage. These instructions indicate the level of potential hazard with the labels of “Caution,” “Warning” or “Danger.” They are all important notes for safety and must be followed in addition to International Standards (ISO/IEC)*1), and other safety regulations.

*1) ISO 4414: Pneumatic fluid power -- General rules relating to systems.

ISO 4413: Hydraulic fluid power -- General rules relating to systems.

IEC 60204-1: Safety of machinery -- Electrical equipment of machines .(Part 1: General requirements)

ISO 10218: Manipulating industrial robots -Safety.

etc.



Caution

Caution indicates a hazard with a low level of risk which, if not avoided, could result in minor or moderate injury.



Warning

Warning indicates a hazard with a medium level of risk which, if not avoided, could result in death or serious injury.



Danger

Danger indicates a hazard with a high level of risk which, if not avoided, will result in death or serious injury.

Warning

1. The compatibility of the product is the responsibility of the person who designs the equipment or decides its specifications.

Since the product specified here is used under various operating conditions, its compatibility with specific equipment must be decided by the person who designs the equipment or decides its specifications based on necessary analysis and test results.

The expected performance and safety assurance of the equipment will be the responsibility of the person who has determined its compatibility with the product.

This person should also continuously review all specifications of the product referring to its latest catalog information, with a view to giving due consideration to any possibility of equipment failure when configuring the equipment.

2. Only personnel with appropriate training should operate machinery and equipment.

The product specified here may become unsafe if handled incorrectly.

The assembly, operation and maintenance of machines or equipment including our products must be performed by an operator who is appropriately trained and experienced.

3. Do not service or attempt to remove product and machinery/equipment until safety is confirmed.

1. The inspection and maintenance of machinery/equipment should only be performed after measures to prevent falling or runaway of the driven objects have been confirmed.

2. When the product is to be removed, confirm that the safety measures as mentioned above are implemented and the power from any appropriate source is cut, and read and understand the specific product precautions of all relevant products carefully.

3. Before machinery/equipment is restarted, take measures to prevent unexpected operation and malfunction.

4. Contact SMC beforehand and take special consideration of safety measures if the product is to be used in any of the following conditions.

1. Conditions and environments outside of the given specifications, or use outdoors or in a place exposed to direct sunlight.

2. Installation on equipment in conjunction with atomic energy, railways, air navigation, space, shipping, vehicles, military, medical treatment, combustion and recreation, or equipment in contact with food and beverages, emergency stop circuits, clutch and brake circuits in press applications, safety equipment or other applications unsuitable for the standard specifications described in the product catalog.

3. An application which could have negative effects on people, property, or animals requiring special safety analysis.

4. Use in an interlock circuit, which requires the provision of double interlock for possible failure by using a mechanical protective function, and periodical checks to confirm proper operation.



Safety Instructions

Caution

The product is provided for use in manufacturing industries.

The product herein described is basically provided for peaceful use in manufacturing industries. If considering using the product in other industries, consult SMC beforehand and exchange specifications or a contract if necessary.

If anything is unclear, contact your nearest sales branch.

Limited warranty and Disclaimer/Compliance Requirements

The product used is subject to the following “Limited warranty and Disclaimer” and “Compliance Requirements”.

Read and accept them before using the product.

Limited warranty and Disclaimer

1. The warranty period of the product is 1 year in service or 1.5 years after the product is delivered, whichever is first. *2)

Also, the product may have specified durability, running distance or replacement parts. Please consult your nearest sales branch.

2. For any failure or damage reported within the warranty period which is clearly our responsibility, a replacement product or necessary parts will be provided.

This limited warranty applies only to our product independently, and not to any other damage incurred due to the failure of the product.

3. Prior to using SMC products, please read and understand the warranty terms and disclaimers noted in the specified catalog for the particular products.

***2) Vacuum pads are excluded from this 1 year warranty.**

A vacuum pad is a consumable part, so it is warranted for a year after it is delivered.

Also, even within the warranty period, the wear of a product due to the use of the vacuum pad or failure due to the deterioration of rubber material are not covered by the limited warranty.

Compliance Requirements

1. The use of SMC products with production equipment for the manufacture of weapons of mass destruction (WMD) or any other weapon is strictly prohibited.

2. The exports of SMC products or technology from one country to another are governed by the relevant security laws and regulation of the countries involved in the transaction. Prior to the shipment of a SMC product to another country, assure that all local rules governing that export are known and followed.

Caution

SMC products are not intended for use as instruments for legal metrology.

Measurement instruments that SMC manufactures or sells have not been qualified by type approval tests relevant to the metrology (measurement) laws of each country.

Therefore, SMC products cannot be used for business or certification ordained by the metrology (measurement) laws of each country.

1. Specifications

Model		MHM-16D□	MHM-25D□	MHM-32D□	MHM-50D□
Pilot port		M5x0.8		Rc1/8	
Fluid		Air			
Action		Double acting			
Operating pressure	Workpiece thickness □ 2 mm	0.2 to 0.6MPa			
	Workpiece thickness > 2 mm	0.2 to 0.6MPa		0.35 to 0.6MPa	
Proof pressure		0.9MPa			
Ambient and fluid temperatures		-10 to 60 °C (No freezing)			
Holding Force *1	Workpiece thickness: 2 mm	50N	160N	250N	400N
	Workpiece thickness: 6 mm	50N	200N	500N	1000N
Residual holding force		0.3 N or less			
Lubrication		Non-lube			

*1 Theoretical holding force (reference value) when a low carbon steel plate is held by entire surface attraction surface

2. Installation

2-1 Design

Warning

1. Confirm the specifications.

Products represented in this catalog are designed only for use in compressed air systems (including vacuum). Do not operate at pressures, temperatures, etc., beyond the range of specifications, as this can cause damage or malfunction. (Refer to the specifications.) Please contact SMC when using a fluid other than compressed air (including vacuum). We do not guarantee against any damages if the product is used outside of the specification range.

2. Take safety measures (e.g. mounting protective covers) when there is a danger of fingers being caught between the magnet gripper and the workpiece or with moving workpieces causing personal injury.

3. Select a model whose holding force is compatible with the workpiece mass.

Expected holding force may not be obtained depending on the material or shape of the workpiece, please evaluate the safety against the fall of workpiece with actual machine.

4. Do not use in applications where excessive external force or impact force may be applied to the gripper.

5. Consider the possibility of a power source related malfunction.

Measures should be taken to prevent injury and equipment damage in the event that there is a power malfunction to equipment controlled by air pressure, electricity or hydraulics, etc.

6. Consider the action of the product in the event of an emergency stop.

Devise a safe system so that if a person engages the emergency stop or if a safety device is tripped during a system malfunction, such as a power outage, the operation of the magnet gripper will not cause a hazard to humans or damage the equipment.

7. Consider the action when operation is restarted after an emergency or abnormal stop.

Design machinery so that bodily injury or equipment damage will not occur upon the restart of operation.

8. Do not disassemble the product or make any modifications, including additional machining.

Doing so may cause human injury and/or an accident.

9. Refer to the Auto Switches Precautions (Web Catalog) if using with an auto switch.

10. Risk to people with pacemakers

The product has a magnet inside. It may interfere with the use of an electronic equipment such as a pacemaker. People with pacemakers should stay away from the magnet gripper or take safety measures to block the magnetic force.

Caution

1. If pressure is applied to the external magnet gripper parts, there is a possibility that air will get inside the cylinder from the rod seal section. (Example : inside a chamber, etc.)
2. Keep away from objects which are influenced by magnets.

As the body magnets are built-in, do not allow close contact with magnetic disks, magnetic cards, or magnetic tapes. Data may be erased.

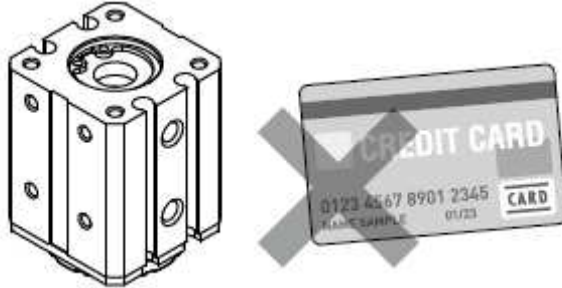

2-2 Mounting

Warning

1. Keep the manual in a safe place for future reference. The product should be mounted and operated only after thoroughly reading the operation manual and understanding its contents.
2. Ensure sufficient space for maintenance activities.

When installing the products, allow access for maintenance and inspection.

3. Observe the tightening torque for screws.

Tighten the screws to the recommended torque for mounting the product.

4. Do not place a magnetic object near the product.

The auto switch is a magnetic sensing type product. If a magnetic object is placed close to it, the product could operate suddenly, which could pose a hazard to humans or damage the machinery and equipment. When the magnet grippers are used in parallel, keep the specified cap between them to avoid malfunction.

5. Do not perform additional machining to the product.

Additional machining to the product can result in insufficient strength and cause damage to the product. This can lead to possible human injury or damage to the surrounding equipment.

6. Do not enlarge the fixed orifice by modifying the pipe connectors.

If the fixed orifice is enlarged, the speed of switching between holding and releasing increases which results in higher impact forces. This may lead to damage to the product, which can lead to human injury and damage to other equipment and machinery.

7. When the magnet moves toward the magnetic attraction surface, holding force is generated on the attraction surface, Make sure that holding force is not generated when working around the magnet gripper so that your fingers do not get caught in the magnet gripper.

Caution

1. Do not scratch or dent the magnet gripper by dropping or bumping it when mounting.

Even a slight deformation can cause malfunction.

2. Be careful with the magnetic attraction of parts of objects around the magnet gripper when mounting the magnet gripper while it is in its holding position (the piston is on the attraction side). They may cause injury.

3. When mounting the product, tighten it with screws of appropriate length at an appropriate torque.

Tightening with a torque greater than the specified torque can cause malfunction, while insufficient tightening can cause slippage and dropping.

1) Lateral mounting

Model	Applicable bolt	Tightening torque (N·m)	Max. screw-in depth L(mm)
MHM-16D□	M3x0.5	0.63	5
MHM-25D□	M4x0.7	1.5	7
MHM-32D□	M5x0.8	3	8
MHM-50D□	M6x1	5.2	9

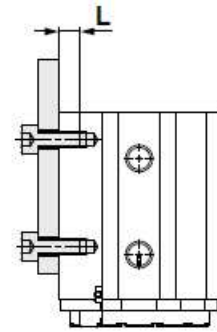

2) Axial mounting (Central mounting type)

Model	Applicable bolt	Tightening torque (N·m)	Max. screw-in depth L(mm)
MHM-16D□	M6x1	5.2	11.5
MHM-25D□	M8x1.25	12.5	12.4
MHM-32D□	M10x1.5	24.5	13.5
MHM-50D□	M12x1.75	42	16

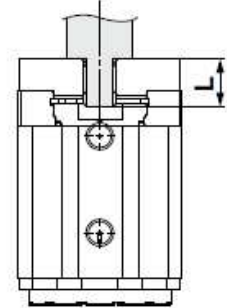

3) Axial mounting (Body tapped)

Model	Applicable bolt	Tightening torque (N·m)	Max. screw-in depth L(mm)
MHM-16D□	M3x0.5	0.63	6
MHM-25D□	M4x0.7	1.5	8
MHM-32D□	M5x0.8	3	10
MHM-50D□	M6x1	5.2	12

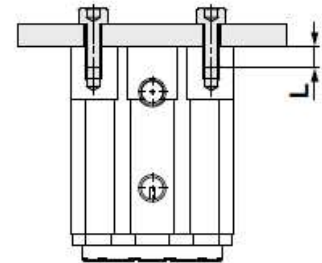

4. The pressing load applied to the workpiece should be smaller than the allowable pressing load.

Model	Allowable pressing load (N)
MHM-16D□	100
MHM-25D□	200
MHM-32D□	300
MHM-50D□	500

Pressing load

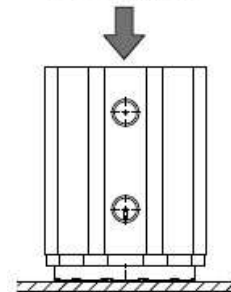

5. Do not apply impact load to the center of the magnetic attraction surface. Otherwise, it may result in a breakage or malfunction.

Center of the attraction surface

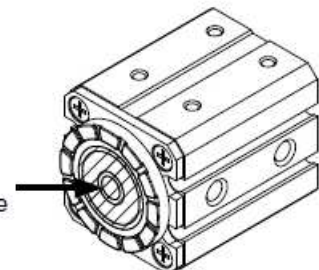

6. The head cap is magnetized during the release of workpiece. Iron particles may be attracted.

Head cap

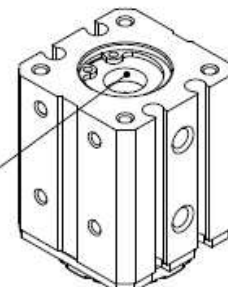

2-3 Environment

Warning

1. Do not use in an atmosphere containing corrosive gases, chemicals, sea water, water, water steam, or where there is direct contact with any of these.

Refer to each construction drawing for information on the materials of air grippers.

2. Do not expose the product to direct sunlight for an extended period of time.

3. Do not use in a place subject to heavy vibration and/or shock.

4. Do not mount the product in locations where it is exposed to radiant heat.

5. Do not use in dusty locations or where water, oil, etc., splash on the equipment.

6. A decrease in the base oil of grease may be accelerated by the properties of the compressed air used in pneumatic equipment, the external environment, operating conditions, etc., and the resulting drop in lubricating performance may have an effect on the equipment's service life.

Caution

1. Internal lubricant or the base oil of grease may seep out of the cylinder depending on the operating conditions (an ambient temperature of 40°C or more, pressure retention, low-frequency actuation, etc.). Take great care when a clean environment is required.

2-4 Air supply

Warning

1. Type of fluids

Please consult with SMC when using the product in applications other than compressed air.

2. When there is a large amount of drainage

Compressed air containing a large amount of drainage can cause the malfunction of pneumatic equipment. An air dryer or water separator should be installed upstream from filters.

3. Drain flushing

If condensation in the drain bowl is not emptied on a regular basis, the bowl will overflow and allow the condensation to enter the compressed air lines. This causes the malfunction of pneumatic equipment. If the drain bowl is difficult to check and remove, the installation of a drain bowl with an auto drain option is recommended. For compressed air quality, refer to the SMC Best Pneumatics No. 6 catalog.

4. Use clean air.

Do not use compressed air that contains chemicals, synthetic oils that include organic solvents, salt, corrosive gases, etc., as it can cause damage or malfunction.

Caution

1. When extremely dry air is used as the fluid, degradation of the lubrication properties inside the equipment may occur, resulting in reduced reliability (or reduced service life) of the equipment. Please consult with SMC.

2. Install an air filter.

Install an air filter upstream near the valve. Select an air filter with a filtration size of 5 µm or smaller.

3. Take measures to ensure air quality, such as by installing an aftercooler, air dryer, or water separator.

Compressed air that contains a large amount of drainage can cause the malfunction of pneumatic equipment, such as air grippers. Therefore, take appropriate measures to ensure air quality, such as by providing an aftercooler, air dryer, or water separator.

4. Ensure that the fluid and ambient temperatures are within the specified range.

If the fluid temperature is 5°C or less, the moisture in the circuit could freeze, causing damage to the seals or equipment malfunction. Therefore, take appropriate measures to prevent freezing. For compressed air quality, refer to the SMC Best Pneumatics No. 6 catalog.

5. Precautionary measures against condensation

Moisture condensation can occur inside pneumatic systems due to a drop in temperatures caused by the piping or operating conditions. This can degrade or wash away grease, resulting in a shortened service life or a malfunction. For details, refer to the catalog "Precautionary measures against condensation in a pneumatic system" (CAT.P-E01-11).

2-5 Piping

1. Preparation before piping

Before piping is connected, it should be thoroughly blown out with air (flushing) or washed to remove chips, cutting oil, and other debris from inside the pipe.

2. Winding of sealant tape

When screwing piping or fittings into ports, ensure that chips from the pipe threads or sealing material do not enter the piping. Also, if sealant tape is used, leave 1.5 to 2 thread ridges exposed at the end of the threads.

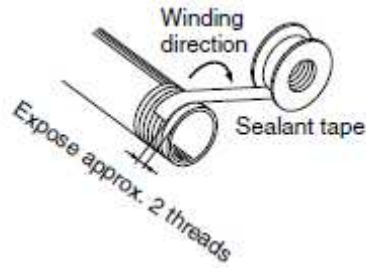

2-6 Lubrication



Caution

Magnet gripper is lubricating non-lube type.

These cylinders have been lubricated for life at the factory and can be used without any further lubrication. However, in the event that it is additionally lubricated, be sure to use class 1 turbine oil (with no additives) ISO VG320. Do not use machine oil or spindle oil. Stopping lubrication later on may lead to a malfunction because the new lubricant will displace the original lubricant. Therefore, lubrication must be continued once it has been started. If turbine oil is used, refer to the corresponding Safety Data Sheet (SDS).

2-7 Auto Switch Mounting

Auto Switch Mounting Position Setting

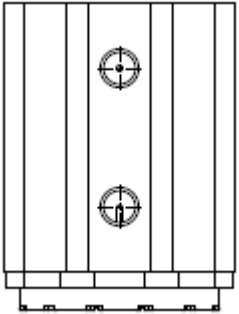
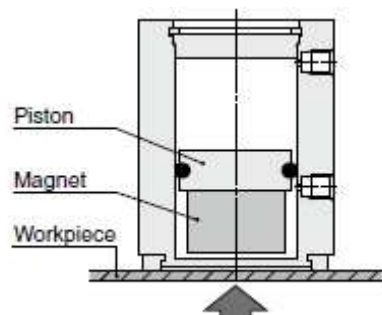
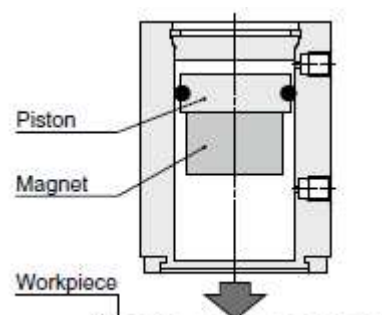
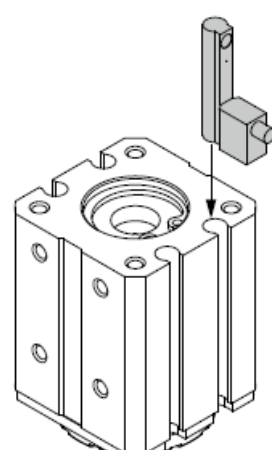
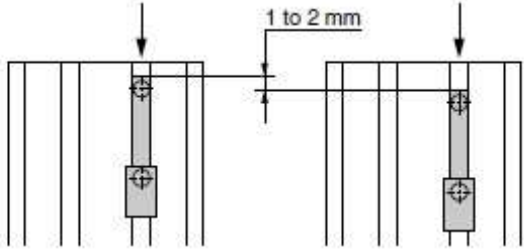
<p>Detection example</p>	<p>1) Detect the magnet position for workpiece holding.</p>	<p>2) Detect the magnet position for workpiece release.</p>
<p>Position to be detected Head side</p>  <p>Attraction side</p>	<p>Magnet attraction side</p> 	<p>Magnet head side</p> 
<p>How to determine Auto switch installation position</p> <p>Connect the auto switch to a power supply and follow the directions.</p>	<p>Step 1) Hold the workpiece.</p>	<p>Step 1) Release the workpiece.</p>
	<p>Step 2) Insert the auto switch into the auto switch mounting groove from the head side.</p> 	
	<p>Step 3) Slide the auto switch in the direction of the arrow until the indicator light illuminates and fasten it at a position 1 to 2 mm in the direction of the arrow beyond the position where the indicator light illuminates.</p>  <p>Position where light turns ON Position to be secured</p>	

*)The auto switch reacts at 2 places when the magnet is at the head side (workpiece release).
 At C3 in the waveform chart, the magnet position cannot be detected.

C1: Detection area of the magnet position for workpiece release
C2: Detection area of the magnet position for workpiece holding
C3: Area where the magnet position cannot be Detected

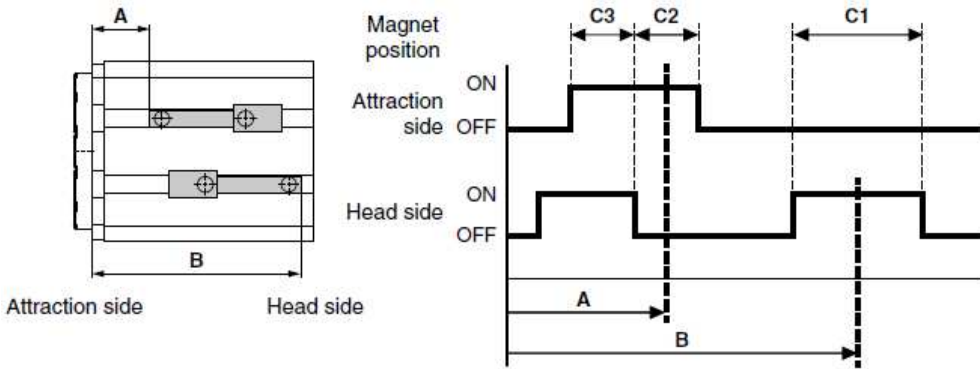

Auto Switch Mounting Position and Mounting Method

Table below shows the mounting positions and dimensions of the auto switch.

Some auto switches may protrude from the end surface of the body. Refer to the table below for the space.

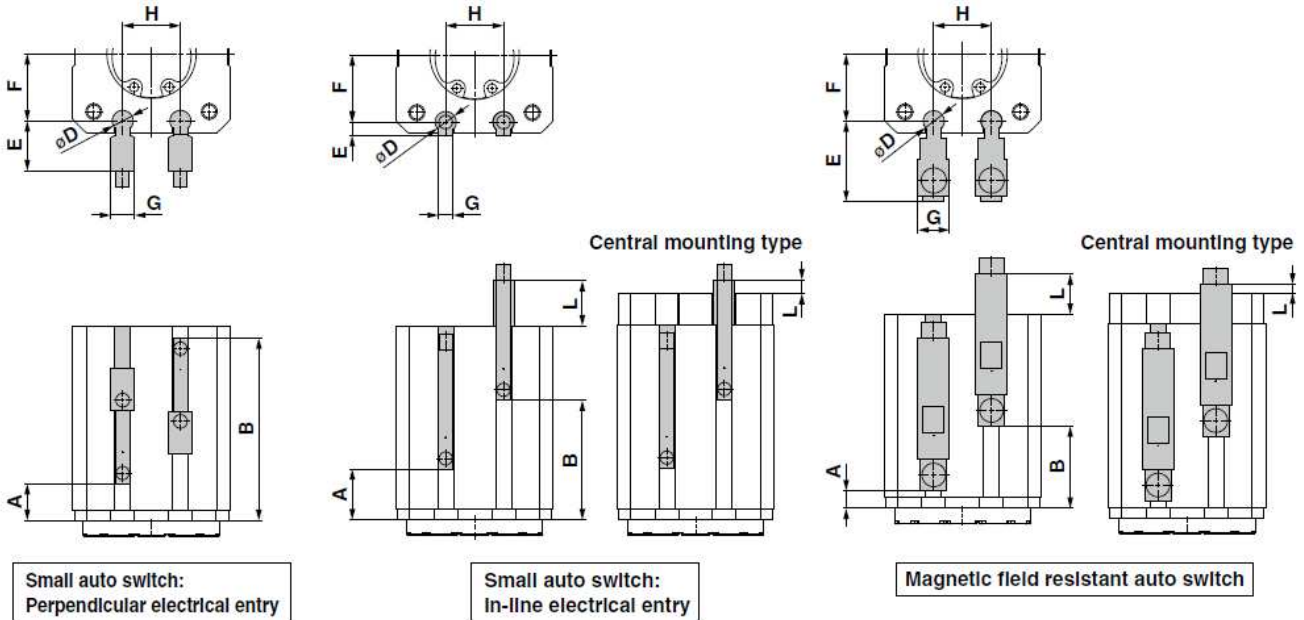

The mounting position

Model	D-M9□V D-M9□WV D-M9□AV				D-M9□ D-M9□W D-M9□A					D-P3DWA□					Common		
	A	B	E	G	A	B	E	G	L	A	B	E	G	L	D	F	H
MHM-16D	9.1	32.6	9.5	4.6	9.1	20.6	2.6	2.8	5.6	4.6	16.1	14.3	6	8.1	4	12.8	11
MHM-16D1	*1				*1				-	*1				2.1			
MHM-16D2	9.1	43.6	9.5	4.6	9.1	31.6	2.6	2.8	-	4.6	27.1	14.3	6	7.1	4	17.5	17
MHM-25D	14.6				*1				4.6	*1				2.1			
MHM-25D1	*1	51.8	9.5	4.6	14.6	39.8	2.6	2.8	4.6	10.1	35.3	14.3	6	7.1	4	17.5	17
MHM-25D2	14.6				*1				10.1	*1				6.3			
MHM-32D	19	51.8	9.5	4.6	19	39.8	2.6	2.8	3.8	14.5	35.3	14.3	6	6.3	4	22.5	23
MHM-32D1	*1				*1				14.5	*1				-			
MHM-32D2	19	66.2	9.5	4.6	19	54.2	2.6	2.8	-	14.5	49.7	14.3	6	-	4	31.5	38
MHM-50D	27.2				*1				22.7	*1				3.7			
MHM-50D1	*1	66.2	9.5	4.6	27.2	54.2	2.6	2.8	1.2	22.7	49.7	14.3	6	3.7	4	31.5	38
MHM-50D2	27.2				*1				22.7	*1				-			

*1 When detecting the magnet position for workpiece holding with adjustable holding force type, the mounting position of the auto switch needs to be changed depending on the adjustment amount of the holding force.

* Dimensions above are for reference. Keep 1 mm or more clearance between the auto switch and peripheral equipment to avoid any interference.

* When mounting the auto switch D-M9m (W or A) V and D-P3DWA to MHM-16Dm, mount them in the groove on the opposite side of the pilot port in order to avoid any interference between the fitting and speed controller.

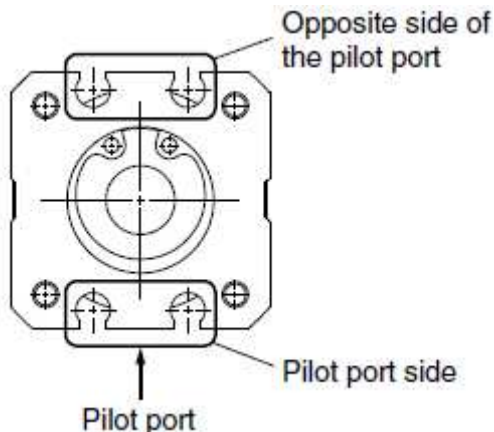

Auto Switch Mounting Method

1. Auto switch mounting tool

When tightening the auto switch mounting screw (included with the auto switch), use a screwdriver with a handle diameter of about 5 to 6 mm.

Tightening Torque for Auto Switch Mounting Screws(N·m)

Auto switch model	Tightening torque
D-M9□(V) D-M9□W(V) D-M9□A(V) D-P3DWA□	0.05 to 0.15

The indicator light may turn on when the tip of the screwdriver is close to the auto switch mounting screw. This is not a malfunction. Keep the screwdriver away from the auto switch when searching mounting position of the auto switch where it operates correctly.

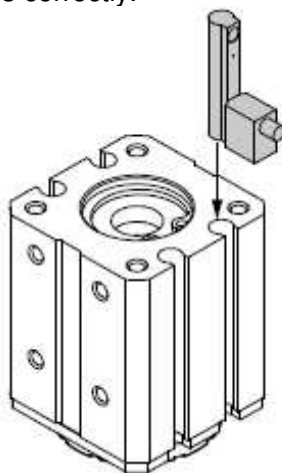

2. Keep a gap wider than the values listed in the table when arranging the magnet grippers side by side or when placing the magnet grippers close to magnetic objects such as iron.

Required Gap (mm)

Model	L1	L2	L3	L4	L5	L6
MHM-16D□	1	1	1	1	16	5
MHM-25D□					36	34
MHM-32D□					50	24
MHM-50D□			23	25	80	41

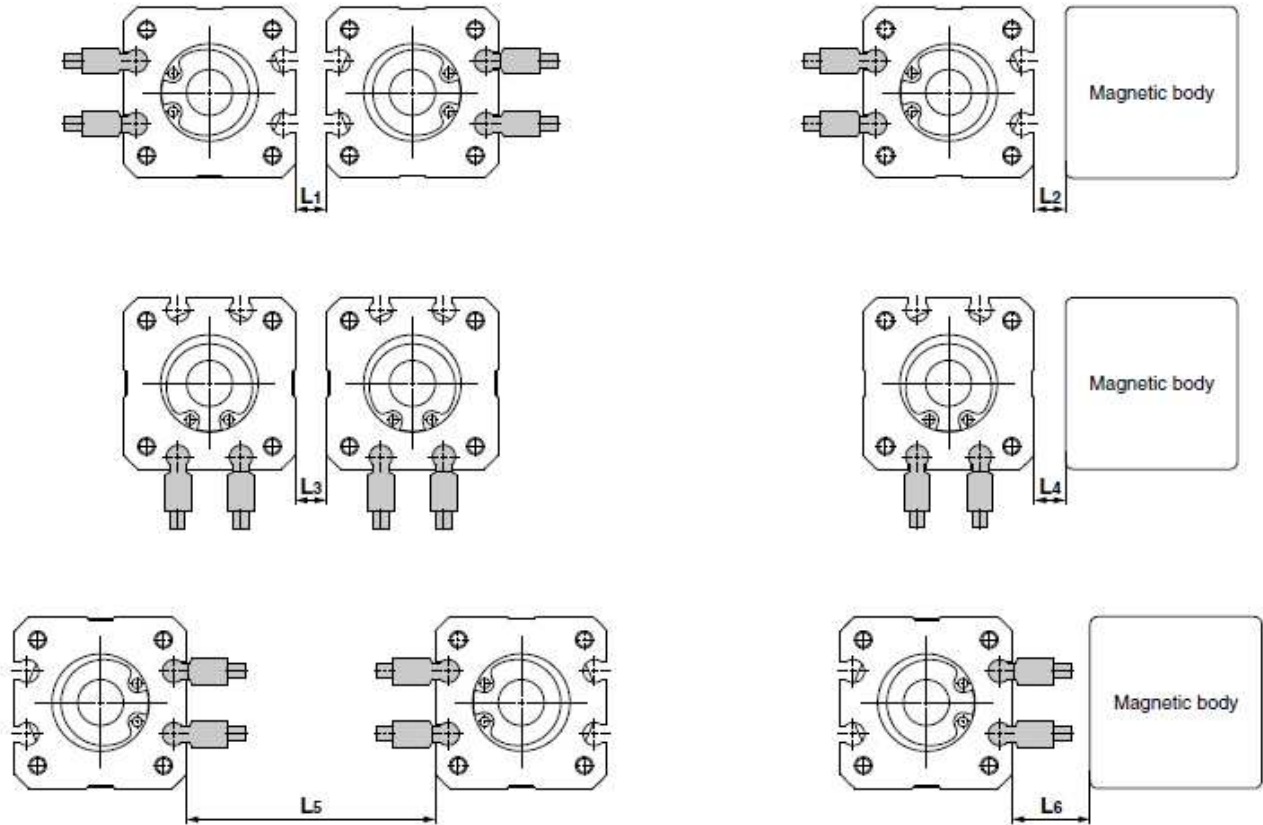

Auto Switch Connections and Examples

Sink Input Specifications

3-wire, NPN

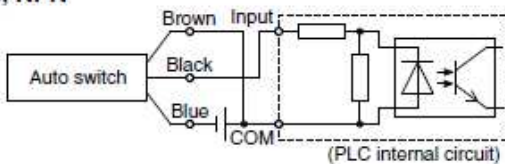

2-wire

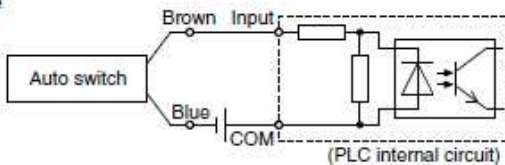

Source Input Specifications

3-wire, PNP

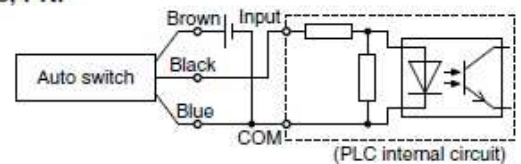

2-wire

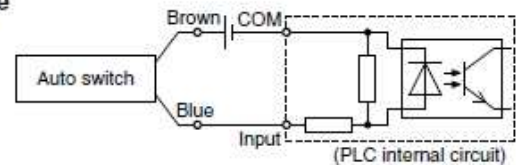

Connect according to the applicable PLC input specifications, as the connection method will vary depending on the PLC input specifications.

Examples of AND (Series) and OR (Parallel) Connections

When using solid state auto switches, ensure the application is set up so the signals for the first 50 ms are invalid. Depending on the operating environment, the product may not operate properly.

3-wire AND connection for NPN output (Using relays)

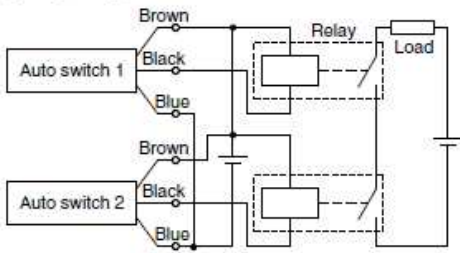

(Performed with auto switches only)

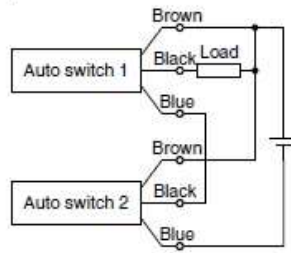

3-wire OR connection for NPN output

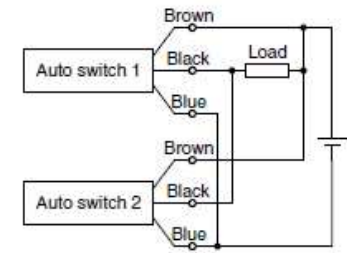

3-wire AND connection for PNP output (Using relays)

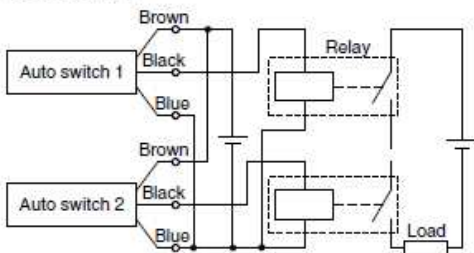

(Performed with auto switches only)

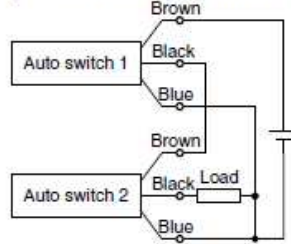

3-wire OR connection for PNP output



2-wire AND connection

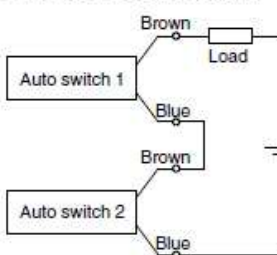

When two auto switches are connected in series, a load may malfunction because the load voltage will decline when in the ON state. The indicator lights will light up when both of the auto switches are in the ON state. Auto switches with a load voltage less than 20 V cannot be used.

$$\begin{aligned} \text{Load voltage at ON} &= \text{Power supply voltage} - \\ &\quad \text{Residual voltage} \times 2 \text{ pcs.} \\ &= 24 \text{ V} - 4 \text{ V} \times 2 \text{ pcs.} \\ &= 16 \text{ V} \end{aligned}$$

Example: Power supply is 24 VDC
Internal voltage drop in auto switch is 4 V.

2-wire OR connection

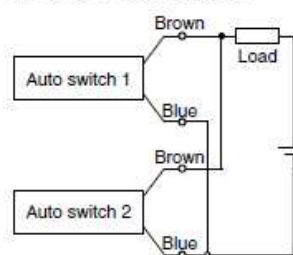

(Solid state)
When two auto switches are connected in parallel, malfunction may occur because the load voltage will increase when in the OFF state.

(Reed)
Because there is no current leakage, the load voltage will not increase when turned OFF. However, depending on the number of auto switches in the ON state, the indicator lights may sometimes grow dim or not light up, due to the dispersion and reduction of the current flowing to the auto switches.

$$\begin{aligned} \text{Load voltage at OFF} &= \text{Leakage current} \times 2 \text{ pcs.} \times \\ &\quad \text{Load impedance} \\ &= 1 \text{ mA} \times 2 \text{ pcs.} \times 3 \text{ k}\Omega \\ &= 6 \text{ V} \end{aligned}$$

Example: Load impedance is 3 k Ω .
Leakage current from auto switch is 1 mA.

2-8 Other

- 1) Refer to the Fittings and Tubing Precautions (Web Catalog) for handling One-touch fittings.
- 2) Ensure the mounting bracket or peripheral parts are not protruded from the magnetic attraction surface. Protrusion reduces the holding force and causes the workpiece to slip or fall.

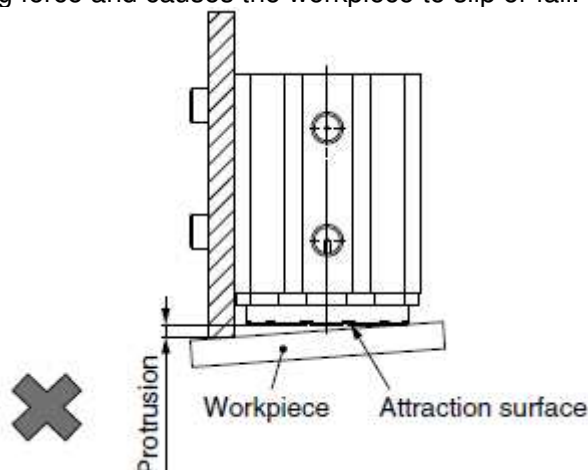

⚠ Caution

3) When multiple magnet grippers are used side by side, mount them so that the attraction surfaces are not uneven. Otherwise, adequate holding force is not available and the workpiece may slip or fall.

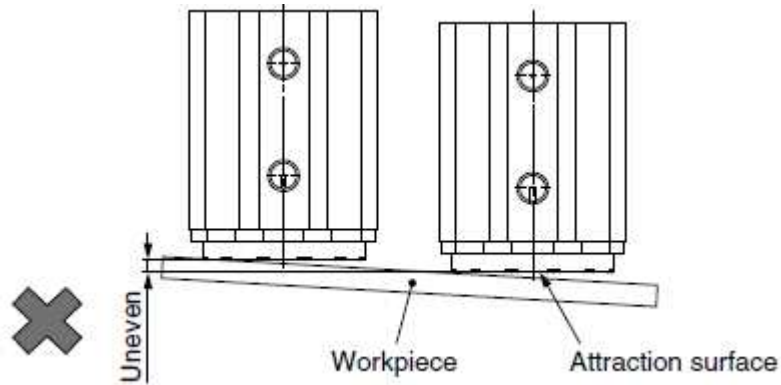

3.Adjustment

Holding Force Adjustment

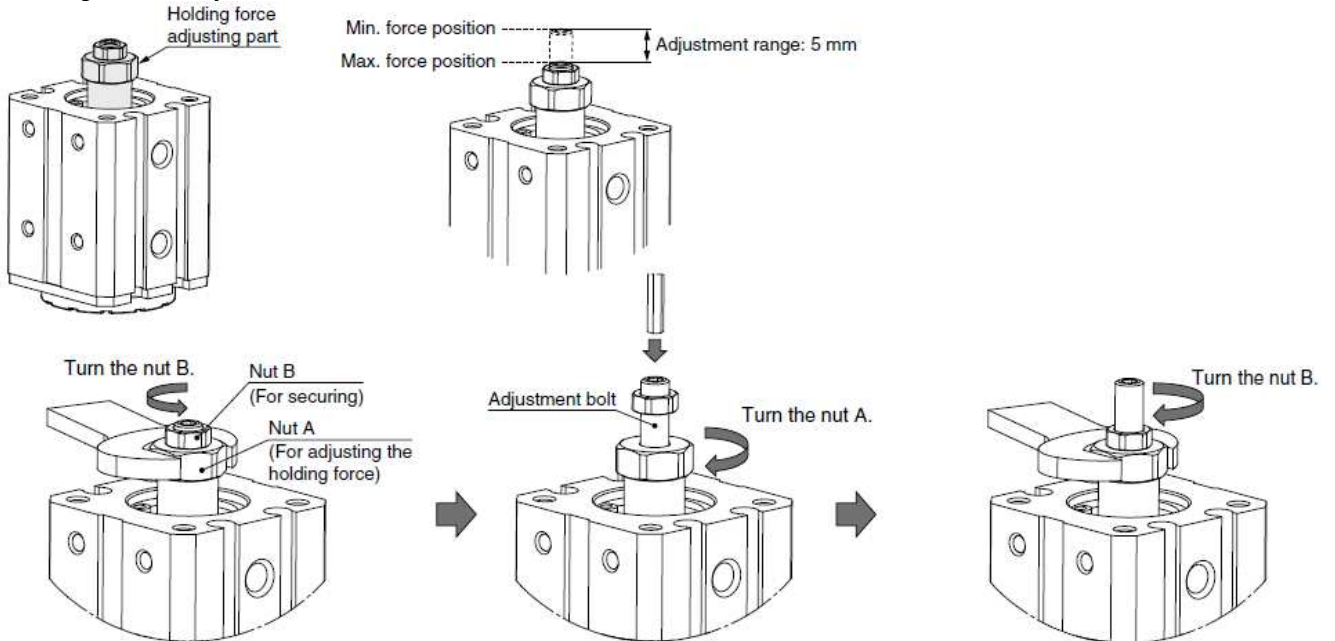

1. Turn the nut B to loosen while holding the nut A. (Nuts are tightened to a specified torque around the maximum holding force position (zero adjustment).)

2. Hold the adjustment bolt while holding the workpiece. Turn the nut A to adjust the holding force.

3. Turn the nut B to tighten at the specified torque while holding the nut A.

Model	Width across flats			Tightening torque for nut B (N · m)	Holding force Adjustment bolt Nut A Nut B adjustment range
	Adjustment bolt	Nut A	Nut B		
MHM-16D1	2	10	6	1.5	5
MHM-25D1	3	14	8	5.2	5
MHM-32D1	3	14	8	5.2	5
MHM-50D1	5	24	17	42	5



Caution

1. Do not apply external forces to the holding force adjusting part other than for the purpose of holding force adjustment.

Do not fix the holding force adjusting part to the outside or attempt to rotate it.

2. Take safety measures during the adjustment of the holding force. The workpiece may drop.

3. For vertical mounting of the holding force adjusting type, keep space shown below around the force adjusting part.

Model	Required hole diameter ϕD (mm)	Required length L (mm)
MHM-16D1	14	25
MHM-25D1	19	37
MHM-32D1	19	43
MHM-50D1	30	63

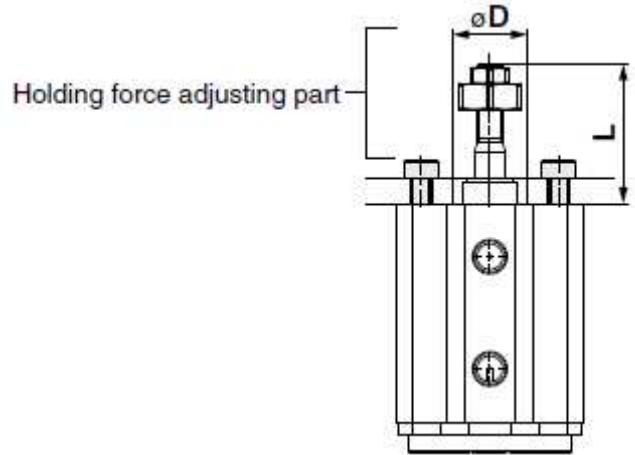

4. How to order

MHM-32D1-M9BW

Bore size

16	16 mm
25	25 mm
32	32 mm
50	50 mm

Action: Double acting

Body type

Nil	Basic type
1	Adjustable holding force type
2	Central mounting type

Number of auto switches

Nil	2
S	1
n	n

Auto switch

Nil	Without auto switch
-----	---------------------

* For applicable auto switches, refer to the table below.

Applicable Auto Switches/Refer to the **Web Catalog** or Best Pneumatics Catalog for further information on auto switches.

Small Auto Switches

Type	Special function	Electrical entry	Indicator light	Wiring (Output)	Load voltage		Auto switch model		Lead wire length [m]				Pre-wired connector	Applicable load
					DC	AC	Perpendicular	In-line	0.5 (Nil)	1 (M)	3 (L)	5 (Z)		
Solid state auto switch	—	Grommet	Yes	3-wire (NPN)	5 V, 12 V	—	M9NV	M9N	●	●	●	○	○	IC circuit
				3-wire (PNP)			M9PV	M9P	●	●	●	○	○	
				2-wire	12 V	M9BV	M9B	●	●	●	○	○	—	
				3-wire (NPN)		M9NWV	M9NW	●	●	●	○	○		
	Diagnostic indication (2-color indicator)			3-wire (PNP)	5 V, 12 V	M9PWV	M9PW	●	●	●	○	○	IC circuit	
				2-wire		M9BWV	M9BW	●	●	●	○	○		
	Water resistant (2-color indicator)			3-wire (NPN)	5 V, 12 V	M9NAV ^{*1}	M9NA ^{*1}	○	○	●	○	○	IC circuit	
				3-wire (PNP)		M9PAV ^{*1}	M9PA ^{*1}	○	○	●	○	○		
				2-wire	12 V	M9BAV ^{*1}	M9BA ^{*1}	○	○	●	○	○	—	
				2-wire				○	○	●	○	○		

*1 Water-resistant type auto switches can be mounted on the above models, but SMC cannot guarantee water resistance. Please contact SMC for water-resistant products.

* Lead wire length symbols: 0.5 m..... Nil (Example) M9NW
 1 m..... M (Example) M9NWM
 3 m..... L (Example) M9NWL
 5 m..... Z (Example) M9NWZ

* Solid state auto switches marked with "○" are produced upon receipt of order.
 * Auto switches are shipped together with the product but do not come assembled.

Magnetic Field Resistant Auto Switches

Type	Auto switch model	Applicable magnetic field	Electrical entry	Indicator light	Wiring (Pin no. in use)	Load voltage	Lead wire length	Applicable load
Solid state auto switch	P3DWA	AC magnetic field (Single-phase AC welding magnetic field)	Grommet	2-color	2-wire	24 VDC	0.5 m	Relay, PLC
	P3DWAL						3 m	
	P3DWAZ						5 m	
	P3DWA						Pre-wired connector	
	P3DWA		2-wire (1-4)					
						0.3 m		

5. Maintenance

5-1 Maintenance or inspection



Warning

1. Perform maintenance and inspection according to the procedures indicated in the operation manual.

If handled improperly, human injury and/or malfunction or damage of machinery and equipment may occur.

2. Maintenance work

If handled improperly, compressed air can be dangerous. Assembly, handling, repair, and element replacement of pneumatic systems should be performed by a knowledgeable and experienced person.

3. Drain flushing

Remove drainage from air filters regularly.

4. Removal of equipment, and supply/exhaust of compressed air

Before components are removed, first confirm that measures are in place to prevent workpieces from dropping, run-away equipment, etc. Then, cut off the supply pressure and electric power, and exhaust all compressed air from the system using the residual pressure release function. When machinery is restarted, proceed with caution after confirming that appropriate measures are in place to prevent sudden movement.

5-2 replacement part

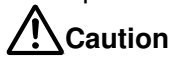

Caution

1) When mounting the adapter for central mounting type, tighten it at an appropriate torque using the accessory bolts.

Tightening with a torque greater than the specified torque can cause malfunction, while insufficient tightening can cause slippage and dropping.

Model	Adapter for Central Mounting Type	Applicable bolt	Tightening torque (N·m)
MHM-16D□	MHM-A1612	M3x0.5	0.63
MHM-25D□	MHM-A2512	M4x0.7	1.5
MHM-32D□	MHM-A3212	M5x0.8	3
MHM-50D□	MHM-A5012	M6x1	5.2

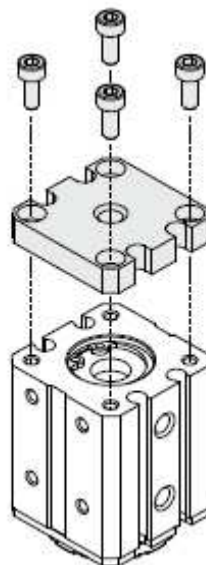

Mounting to the basic type

2) Replace the pad using the following procedure.

Model	Pad
MHM-16D□	MHM-A1613
MHM-25D□	MHM-A2513
MHM-32D□	MHM-A3213
MHM-50D□	MHM-A5013

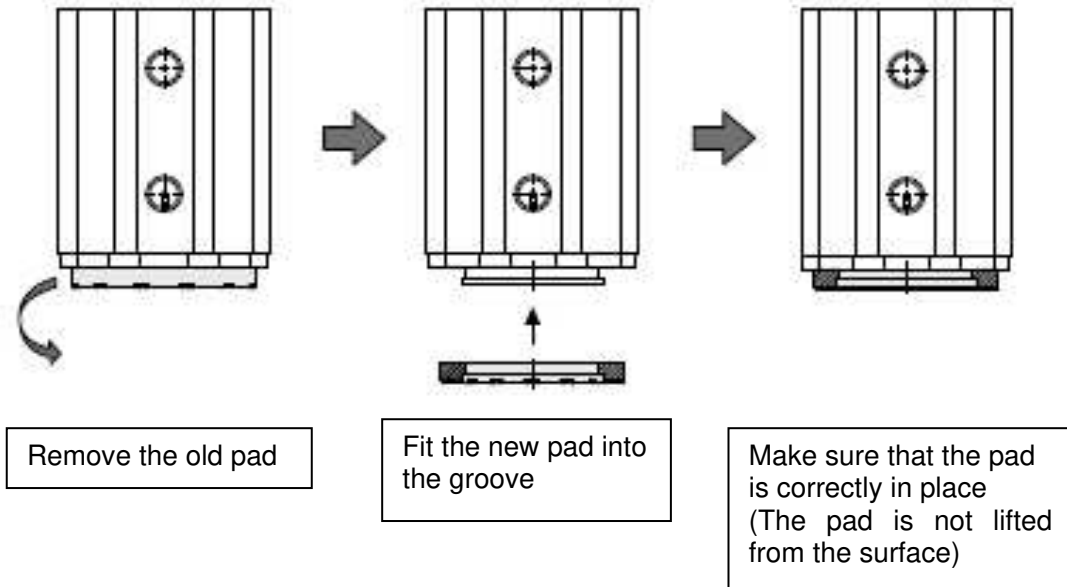

5-3 Maintenance

Warning

There is a strong magnet in the magnet gripper. Do not disassemble the product as the magnet may attract parts and peripheral objects which may cause an accident. When it is necessary to disassemble, please contact the SMC Sales representative.

Revision history

SMC Corporation

4-14-1, Sotokanda, Chiyoda-ku, Tokyo 101-0021 JAPAN
Tel: + 81 3 5207 8249 Fax: +81 3 5298 5362
URL <https://www.smcworld.com>

Note: Specifications are subject to change without prior notice and any obligation on the part of the manufacturer.
© 2019 SMC Corporation All Rights Reserved