



Operation Manual

PRODUCT NAME

Flow Sensor

MODEL / Series / Product Number

PF2A5##

SMC Corporation



Table of Contents

Safety Instructions	2
Model Indication and How to Order	10
Summary of Product parts	12
Definition and terminology	13
Mounting and Installation	14
Installation	14
Piping	15
Wiring	16
Troubleshooting	20
Cross-reference for troubleshooting	20
Specifications	21
Specifications	21
Characteristics data	22
Dimensions	23

Safety Instructions

These safety instructions are intended to prevent hazardous situations and/or equipment damage. These instructions indicate the level of potential hazard with the labels of "Caution", "Warning" or "Danger". They are all important notes for safety and must be followed in addition to International standards (ISO/IEC) *1) and other safety regulations.

- *1) ISO 4414: Pneumatic fluid power -- General rules relating to systems
- ISO 4413: Hydraulic fluid power -- General rules relating to systems
- IEC 60204-1: Safety of machinery -- Electrical equipment of machines (Part 1: General requirements)
- ISO 10218-1992: Manipulating industrial robots -Safety.
- etc.

-  **Caution** : CAUTION indicates a hazard with a low level of risk which, if not avoided, could result in minor or moderate injury.
-  **Warning** : WARNING indicates a hazard with a medium level of risk which, if not avoided, could result in death or serious injury.
-  **Danger** : DANGER indicates a hazard with a high level of risk which, if not avoided, will result in death or serious injury.

Warning

1. The compatibility of the product is the responsibility of the person who designs the equipment or decides its specifications.

Since the product specified here is used under various operating conditions, its compatibility with specific equipment must be decided by the person who designs the equipment or decides its specifications based on necessary analysis and test results. The expected performance and safety assurance of the equipment will be the responsibility of the person who has determined its compatibility with the product. This person should also continuously review all specifications of the product referring to its latest catalog information, with a view to giving due consideration to any possibility of equipment failure when configuring the equipment.

2. Only personnel with appropriate training should operate machinery and equipment.

The product specified here may become unsafe if handled incorrectly. The assembly, operation and maintenance of machines or equipment including our products must be performed by an operator who is appropriately trained and experienced.

3. Do not service or attempt to remove product and machinery/equipment until safety is confirmed.

1. The inspection and maintenance of machinery/equipment should only be performed after measures to prevent falling or runaway of the driven objects have been confirmed.
2. When the product is to be removed, confirm that the safety measures as mentioned above are implemented and the power from any appropriate source is cut, and read and understand the specific product precautions of all relevant products carefully.
3. Before machinery/equipment is restarted, take measures to prevent unexpected operation and malfunction.

4. Contact SMC beforehand and take special consideration of safety measures if the product is to be used in any of the following conditions.

1. Conditions and environments outside of the given specifications, or use outdoors or in a place exposed to direct sunlight.
2. Installation on equipment in conjunction with atomic energy, railways, air navigation, space, shipping, vehicles, military, medical treatment, combustion and recreation, or equipment in contact with food and beverages, emergency stop circuits, clutch and brake circuits in press applications, safety equipment or other applications unsuitable for the standard specifications described in the product catalog.
3. An application which could have negative effects on people, property, or animals requiring special safety analysis.
4. Use in an interlock circuit, which requires the provision of double interlock for possible failure by using a mechanical protective function, and periodical checks to confirm proper operation.

Caution

The product is provided for use in manufacturing industries.

The product herein described is basically provided for peaceful use in manufacturing industries. If considering using the product in other industries, consult SMC beforehand and exchange specifications or a contract if necessary.
If anything is unclear, contact your nearest sales branch.

Limited warranty and Disclaimer/Compliance Requirements

The product used is subject to the following "Limited warranty and Disclaimer" and "Compliance Requirements".

Read and accept them before using the product.

Limited warranty and Disclaimer

1. The warranty period of the product is 1 year in service or 1.5 years after the product is delivered. *2)
Also, the product may have specified durability, running distance or replacement parts. Please consult your nearest sales branch.
2. For any failure or damage reported within the warranty period which is clearly our responsibility, a replacement product or necessary parts will be provided.
This limited warranty applies only to our product independently, and not to any other damage incurred due to the failure of the product.
3. Prior to using SMC products, please read and understand the warranty terms and disclaimers noted in the specified catalog for the particular products.

*2) Vacuum pads are excluded from this 1 year warranty.

A vacuum pad is a consumable part, so it is warranted for a year after it is delivered.

Also, even within the warranty period, the wear of a product due to the use of the vacuum pad or failure due to the deterioration of rubber material are not covered by the limited warranty.

Compliance Requirements

1. The use of SMC products with production equipment for the manufacture of weapons of mass destruction (WMD) or any other weapon is strictly prohibited.
2. The exports of SMC products or technology from one country to another are governed by the relevant security laws and regulation of the countries involved in the transaction. Prior to the shipment of a SMC product to another country, assure that all local rules governing that export are known and followed.

Operator

- ◆ This operation manual is intended for those who have knowledge of machinery using pneumatic equipment, and have sufficient knowledge of assembly, operation and maintenance of such equipment. Only those persons are allowed to perform assembly, operation and maintenance.
- ◆ Read and understand this operation manual carefully before assembling, operating or providing maintenance to the product.

■ Safety Instructions

Warning

- Do not disassemble, modify (including changing the printed circuit board) or repair.
An injury or failure can result.
- Do not operate the product outside of the specifications.
Do not use for flammable or harmful fluids.
Fire, malfunction, or damage to the product can result.
Verify the specifications before use.
- Do not operate in an atmosphere containing flammable, explosive or corrosive gas.
Fire or an explosion can result.
This product is not designed to be explosion proof.
- Do not use the product for flammable fluid.
A fire or explosion can result.
- Do not use the product in a place where static electricity is a problem.
Otherwise it can cause failure or malfunction of the system.
- If using the product in an interlocking circuit:
 - Provide a double interlocking system, for example a mechanical system
 - Check the product regularly for proper operationOtherwise malfunction can result, causing an accident.
- The following instructions must be followed during maintenance:
 - Turn off the power supply
 - Stop the air supply, exhaust the residual pressure and verify that the air is released before performing maintenance workOtherwise an injury can result.

Caution

- Do not touch the terminals and connectors while the power is on.
Otherwise electric shock, malfunction or damage to the product can result.
- After maintenance is complete, perform appropriate functional inspections and leak tests.
Stop operation if the equipment does not function properly or there is a leakage of fluid.
When leakage occurs from parts other than the piping, the product might be faulty.
Disconnect the power supply and stop the fluid supply.
Do not apply fluid under leaking conditions.
Safety cannot be assured in the case of unexpected malfunction.

■NOTE

- Follow the instructions given below when designing, selecting and handling the product.
- The instructions on design and selection (installation, wiring, environment, adjustment, operation, maintenance, etc.) described below must also be followed.
- *Product specifications
 - Use the specified voltage.
 - Otherwise failure or malfunction can result.
 - Insufficient supply voltage may not drive a load due to a voltage drop inside the product.
 - Verify the operating voltage of the load before use.
 - Do not exceed the specified maximum allowable load.
 - Otherwise it can cause damage or shorten the lifetime of the product.
 - The applicable fluids are air and Nitrogen.
 - The fluid temperature range is 0 to 50 °C.
 - Before designing piping confirm the pressure loss at the sensor from the pressure loss graph.
 - Confirm pressure loss of the sensor from the characteristics data.
 - Do not use compressed air containing a lot of condensate.
 - Insufficient air quality can cause operating failure.
 - If compressed air containing condensate is used, install an air dryer or drain catch before the filter and perform draining regularly.
 - Use the specified measurement flow rate and operating pressure.
 - Otherwise it can cause damage to the product or inability to measure correctly.
 - Reserve a space for maintenance.
 - Allow sufficient space for maintenance when designing the system.

●Product handling

*Installation

- Tighten to the specified tightening torque.
If the tightening torque is exceeded the mounting screws and brackets may be damaged.
If the tightening torque is insufficient, the product may be displaced and the mounting screws may come loose.
(Refer to page 14 "Mounting and Installation".)
- Ensure that the FG terminal is connected to ground when using a commercially available switch-mode power supply.
- Do not drop, hit or apply excessive shock to the product.
Otherwise damage to the internal parts can result, causing malfunction.
- Do not pull the lead wire forcefully, or lift the product by the lead wire. (Tensile force 49 N or less)
Hold the product body when handling, to prevent damage, failure or malfunction.
- For piping of the product, hold the piping with a spanner on the metal part of the product (Piping attachment).
Holding other parts with a spanner leads to may damage the product.
- Any dust left in the piping should be flushed out by air blow before connecting the piping to the product.
Otherwise damage or malfunction can result.
- Refer to the flow direction of the fluid indicated on the product label for installation and piping.
Remaining air can cause inability to measure accurately.
- Do not mount the body with the bottom facing upwards.
Retention of air can cause inability to measure accurately.
- Avoid piping in which the piping size of the IN side of the product changes suddenly.
If the piping size is reduced sharply or there is a restrictor such as a valve on the IN side, fluid velocity distribution in the piping will be disturbed, leading to improper measurement.
Therefore, the above-mentioned piping should be connected on the OUT side.
If the orifice of the OUT side is fully closed to operate the pump, the switch may malfunction due to the effect of pulsation (pressure fluctuation). Ensure that there is no malfunction before usage.
- Do not insert metal wires or other foreign matter into the piping port.
This can damage the sensor causing failure or malfunction.
- Never mount a product in a location that will be used as a foothold.
The product may be damaged if excessive force is applied by stepping or climbing onto it.
- If there is a risk of foreign matter entering the fluid, install and pipe a filter or the mist separator at the inlet to avoid failure and malfunction.
Otherwise damage or malfunction can result.
And it can cause inability to measure accurately.

*Wiring

- Do not pull the lead wires.

In particular, never lift a product equipped with fitting and piping by holding the lead wires.

Otherwise damage to the internal parts can result, causing malfunction or disconnection of the connector.

- Avoid repeatedly bending or stretching the lead wire, or placing heavy loads on it.

Repeated bending stress or tensile stress can cause damage to the sheath, or breakage of the wires.

If the lead wire can move, fix it near the body of the product.

The recommended bend radius of the lead wire is 6 times the outside diameter of the sheath, or 33 times the outside diameter of the wire insulation material, whichever is larger.

Replace any damaged lead wire with a new one.

- Wire correctly.

Incorrect wiring can damage the product.

- Do not perform wiring while the power is on.

Otherwise damage to the internal parts can result, causing malfunction.

- Do not route wires and cables together with power or high voltage cables.

Otherwise the product can malfunction due to interference or noise and surge voltage from power and high voltage cables

- Confirm proper insulation of wiring.

Poor insulation (interference from another circuit, poor insulation between terminals, etc.) can lead to excess voltage or current being applied to the product, causing damage.

- Keep wiring as short as possible to prevent interference from electromagnetic noise and surge voltage.

Do not use a cable longer than 10 m.

Wire the DC(-) line (blue) as close as possible to the power supply.

- When analogue output is used, install a noise filter (line noise filter, ferrite element, etc.) between the switch-mode power supply and this product.

*Environment

- Do not use the product in an environment that is constantly exposed to the splash of water.
Otherwise failure or malfunction can result. Take measures such as using a cover.
- Do not use the product in an environment where corrosive gases or fluids could be splashed.
Otherwise damage to the product and malfunction can result.
- Do not use in a place where the product could be splashed by oil or chemicals.
If the product is to be used in an environment containing oils or chemicals such as coolant or cleaning solvent, even for a short time, it may be adversely affected (damage, malfunction, or hardening of the lead wires).
- Do not use in an area where electrical surges are generated.
If there is equipment generates large electrical surges (solenoid type lifter, high frequency induction furnace, motor, etc.) close to the product, damage or failure of the internal circuit may occur. Take measures against the surge sources, and prevent the wires from coming into close contact.
- Do not use a load which generates a surge voltage.
When a surge-generating load such as a relay or solenoid is driven directly, use a product with a built-in surge absorbing element.
- The product is CE marked, but not immune to lightning strikes. Take measures against lightning strikes in the system.
- Do not use the product in areas that are exposed to vibration or impact.
Otherwise failure or malfunction can result.
- Do not use the product in the presence of a magnetic field.
This may lead to the malfunction of the product.
- Prevent foreign matter such as wire debris from entering the product.
Otherwise failure or malfunction can result.
- Do not use the product in areas subject to large temperature cycle.
Heating/cooling cycles other than ordinary changes in temperature can adversely affect the internal structure of the product.
- Do not expose the product to direct sunlight.
If using in a location directly exposed to sunlight, use a suitable protective cover.
Otherwise failure or malfunction can result.
- Keep within the operating fluid temperature and operating temperatures range.
The operating fluid temperature and operating temperature range is 0 to 50 °C.
Operation below the minimum temperature limit may cause damage or operation failure due to frozen moisture in the fluid or air.
Protection against freezing is necessary.
An air dryer is recommended for elimination of drainage and water.
Avoid sudden temperature changes even within the specified temperature range.
- Do not operate close to a heat source, or in a location exposed to radiant heat.
Otherwise malfunction can result.

***Adjustment and Operation**

- Connect load before turning on the power.

Otherwise it can cause excess current causing instantaneous damage to the product.

- Supply the power when there is no flow.

The display and analogue output will drift by approximately 2 to 3%F.S. immediately after the power supply is turned on.

***Maintenance**

- Perform regular maintenance and inspections.

There is a risk of unexpected malfunction of components due to the malfunction of equipment and machinery.

- Turn off the power supply, stop the supplied air, exhaust the residual pressure and verify the release of air before performing maintenance.

There is a risk of unexpected malfunction.

- Perform drainage regularly.

If condensate enters the outside, it can cause operating failure of pneumatic equipment.

- Do not use solvents such as benzene, thinner etc. to clean the product.

They could damage the surface of the body and erase the markings on the body.

Use a soft cloth to remove stains.

For heavy stains, use a cloth lightly dampened with diluted neutral detergent, then wipe up any residue with a dry cloth.

Model indication and How to Order

PF2A 5 - - -

Remote type sensor

Rated flow range

Symbol	Content
10	1 to 10 L/min
50	5 to 50 L/min
11	10 to 100 L/min
21	20 to 200 L/min
51	50 to 500 L/min

Thread type

Symbol	Content
Nil	Rc
N	NPT
F	G

Connector
(Refer to page 11.)

Output specification

Symbol	Content	Applicable monitor model
Nil	Output for PF2A3□□	PF2A3□□ Series
1	Output for PF2A3□□ + Analogue (1 to 5 V)	PF2A3□□ Series, PF2A2□□ Series (Used for analogue output only)
2	Output for PF2A3□□ + Analogue (4 to 20 mA)	PF2A3□□ Series

Lead wire
(Refer to page 11.)

Port size

Symbol	Port size	Rated flow range				
		10	50	11	21	51
01	1/8 inch	●	●	-	-	-
02	1/4 inch	●	●	-	-	-
03	3/8 inch	-	-	●	●	-
04	1/2 inch	-	-	-	-	●

Lead wire

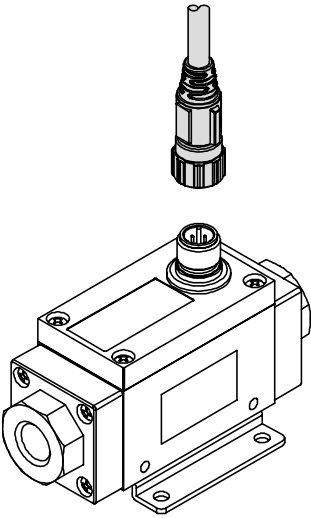
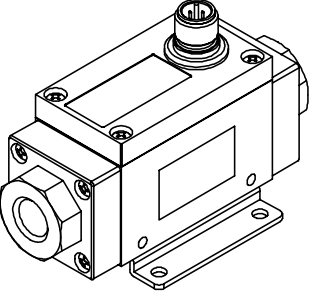
NIL	N
<p data-bbox="225 376 536 439">with lead wire and connector (Straight, 3 m)</p> 	<p data-bbox="746 376 927 405">without lead wire</p> 

*: Lead wire is not assembled with the product, but shipped together.

Connector

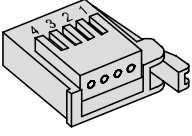
NIL	C
<p data-bbox="284 1207 475 1236">without connector</p>	<p data-bbox="719 1207 954 1236">with connector (1 pc.)</p> 

*: Connector is not assembled with the lead wire, but shipped together.

Accessories / Part number

If an accessory is required separately, order using the following part numbers.

Part number	Description	Remarks	Weight
ZS-37-A	Lead wire and connector (Straight)	Length: 3 m	100 g
ZS-37-B	Lead wire and connector (Right angle)	Length: 3 m	100 g
ZS-29-T	Bracket	Mounting screw (3 x 12 Self tapping screw) 4 pcs.	40 g
ZS-28-CA-4	Connector	1 pc.	2 g

Summary of Product parts

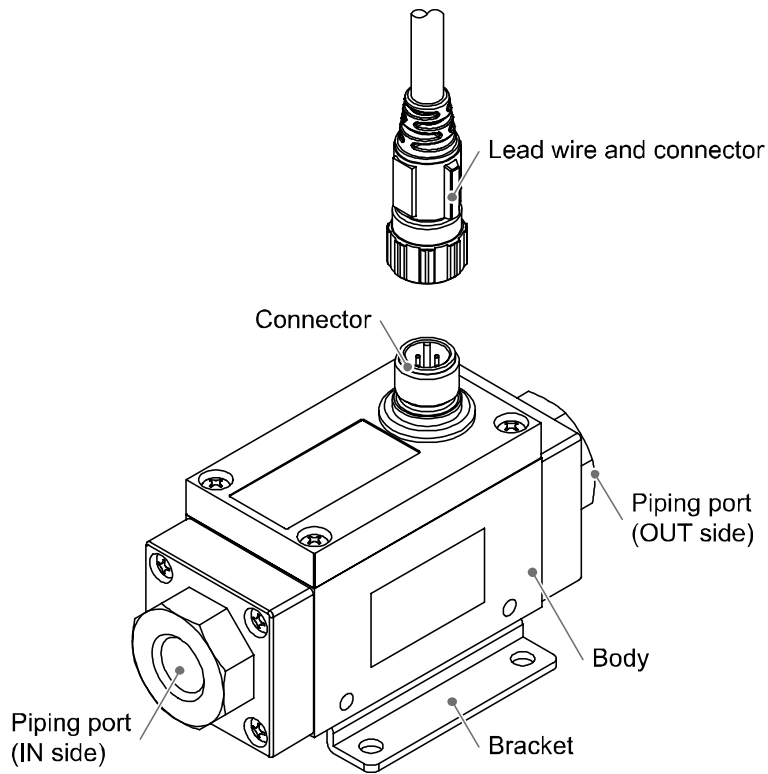

Connector pin numbers
(on the product)

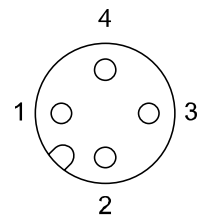

1	DC(+)
2	N.C. / Analogue output
3	DC(-)
4	Output for PF2A3□□

Item	Description
Lead wire and connector	Lead wire to supply power and transmit output signals.
Connector	Connector for electrical connections.
Piping port	Connected to the fluid inlet at IN and to the fluid outlet at OUT.
Bracket	Bracket for mounting the product.
Body	The body of the product.

■ Definition and terminology

	Terms	Meaning
A	Analogue output	A type of variable output that has a value proportional to the measured quantity. When the analogue output is in the range of 1 to 5 V or 4 to 20 mA, it will vary continuously, following the change of flow
	Attachment	A metal part on both sides of the product to connect piping.
F	Fluid temperature	Range of fluid temperature that can be measured by the product.
	F.S. (Full span, Full scale)	Stands for "full span" or "full scale", and indicates varied analogue output range at rated value. For example, when analogue output is 1 to 5 V, F.S. = 5[V] - 1[V] = 4[V], (ref. 1%F.S. = 4[V]x1% = 0.04[V]) The maximum measuring range or change in analogue output over the maximum measurement range.
O	Operating humidity range	The ambient humidity range within which the product will meet all published specifications.
	Operating temperature range	The ambient temperature range within which the product will meet all published specifications.
P	Part in contact with fluid	A part that comes into physical contact with the fluid.
	Pressure characteristics	The amount of variation in the analogue output or display value when the supply pressure is changed.
	Proof pressure	The pressure beyond which the flow switch will be damaged.
R	Rated flow range	The flow range within which the product will meet all published specifications.
	Rated pressure range	The pressure range within which the product will meet all published specifications.
	Repeatability	Reproducibility of the display or analogue output value, when the flow is repeatedly changing.
	Response time	Time from when the target flow is applied until the flow reaches 90% of the set value.
T	Temperature characteristics	The amount of variation in the analogue output or display value when the ambient temperature is changed.

Mounting and Installation

■ Installation

- Never mount the product in a location that will be used as a foothold.

● Installing

- Install the product (with bracket) using the M4 screws (4 pcs).
- Bracket thickness is approximately 1.6 mm.
- Refer to the dimension drawing of the bracket (page 25) for mounting hole dimensions.

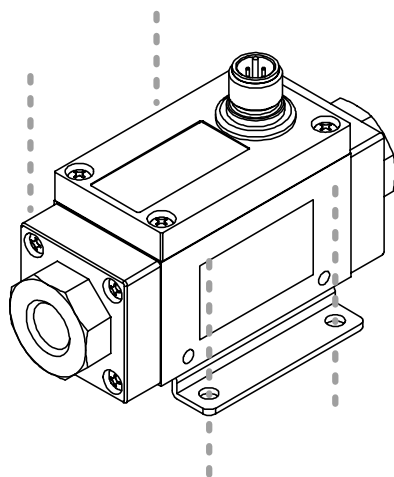

■ Piping

- Use the product within the specified operating pressure range and temperature range.
- Proof pressure is 1.0 MPa.
- Connect the piping to the fittings.
- Mount the product so that the fluid direction is the same as the arrow indicated on the product.
- Never mount the product upside down.
- The piping on the IN side must have a straight section of piping whose length is 8 times the piping diameter or more.
- Avoid sudden changes in the piping size on the IN side of the product.

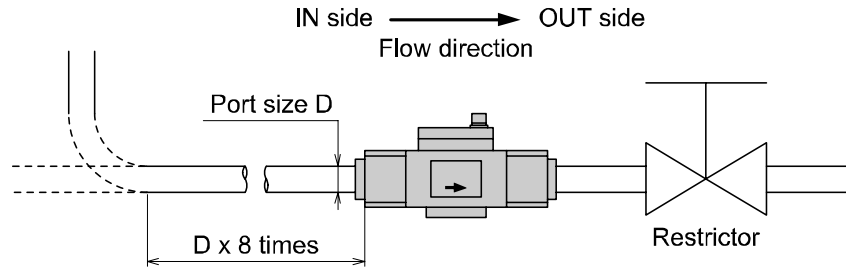

● Connecting the piping

- Ensure that the metal piping attachments are tightened to the required torque (refer to the table below).
- If the tightening torque is exceeded, the product can be broken. If the tightening torque is insufficient, the fittings may become loose.
- When connecting piping to the product, a spanner should be used on the metal piping attachment only. Using a spanner on other parts may damage the product.
- Avoid any sealing tape from entering inside the piping.
- Ensure that there is no leakage from loose piping.

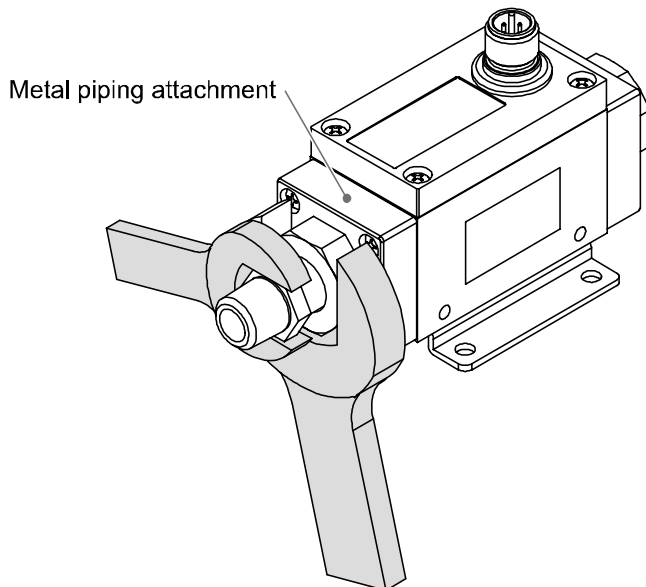

Nominal thread size	Required torque
Rc(NPT)1/8	7 to 9 Nm
Rc(NPT)1/4	12 to 14 Nm
Rc(NPT)3/8	22 to 24 Nm
Rc(NPT)1/2	28 to 30 Nm

Model	Width across flats of attachment
PF2A510	24 mm
PF2A550	
PF2A511	30 mm
PF2A521	
PF2A551	

■Wiring

- Connections should only be made with the power supply turned off.
- Use separate routes for the product wiring and any power or high voltage wiring. Otherwise, malfunction may result due to noise.
- Ensure that the FG terminal is connected to ground when using a commercially available switch-mode power supply. When a switch-mode power supply is connected to the product, switching noise will be superimposed and the product specification can no longer be met. This can be prevented by inserting a noise filter, such as a line noise filter and ferrite core, between the switch-mode power supply and the product, or by using a series power supply instead of a switch-mode power supply.

●Connector Pin numbers

When the lead wire and connector designated for the PF2A5 is used, the wire colours will apply as shown in the diagram.

Connector Pin numbers (on the lead wire)

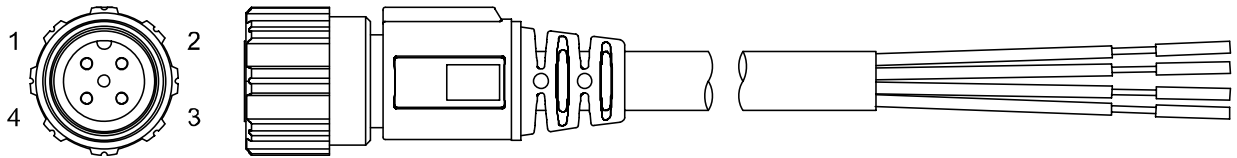

Pin number	Content	Colour
1	DC(+)	Brown
2	N.C. / Analogue output	White
3	DC(-)	Blue
4	Output for PF2A3□□	Black

●Connecting the wiring

How to connect the body and the lead wire and connector

- Align the lead wire connector with the connector key groove, and insert vertically.
- Connection is complete when the knurled part is fully tightened. Check that the connection is not loose.

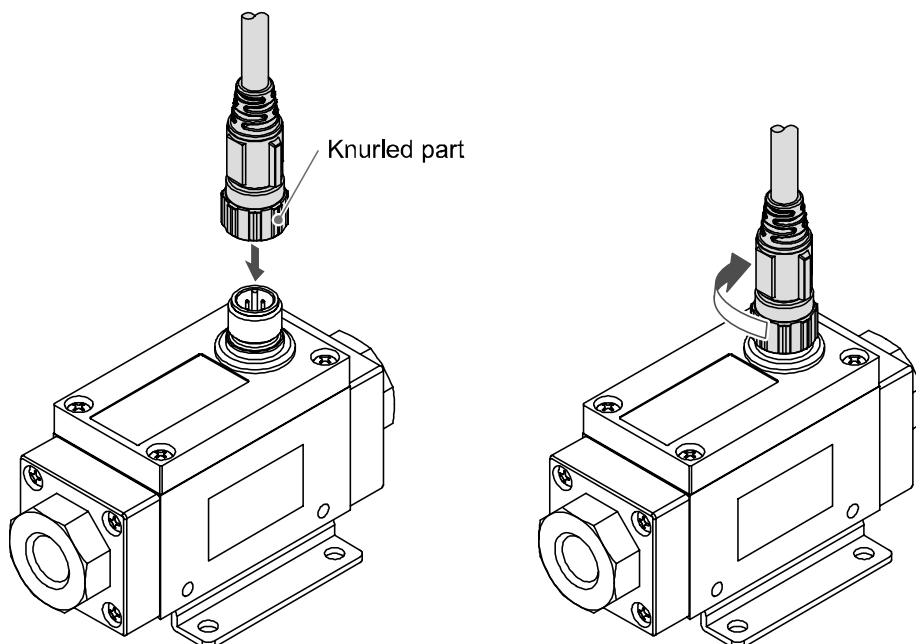

Attaching the sensor connector to the lead wire (When the product connects to the PF2A2□□)

Refer to the PF2A2□□ operation manual for details of the sensor connector pin numbers.

- Strip the lead wire as shown. Do not cut the insulator.

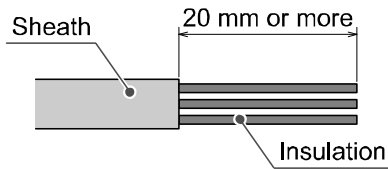

- Insert the corresponding wire colour into the pin number printed on the sensor connector, to the bottom, then part A shown should be pressed in by hand to make temporary connection.

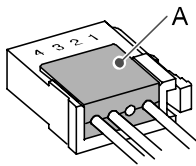

- Part A should then be pressed in using a suitable tool, such as pliers.

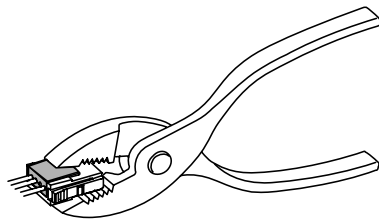

*: The connector cannot be re-used once it has been fully crimped.

In cases of connection failure such as incorrect order of wires or incomplete insertion, please use the new connector.

● Internal circuit and wiring example

When the lead wire and connector designated for the PF2A5 is used, the wire colours will apply as shown in the diagram.

Output for PF2A3□□ type

PF2A5□□-□□□□-□

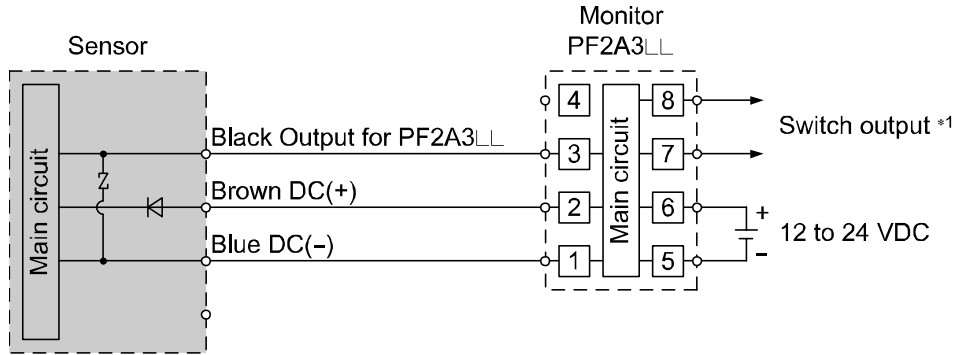

Output impedance: 1 kΩ

*1: Refer to the PF2A3□□ operation manual for details of the flow monitor.

Output for PF2A3□□ + Analogue (1 to 5 V) type

PF2A5□□-□□□□-1-□

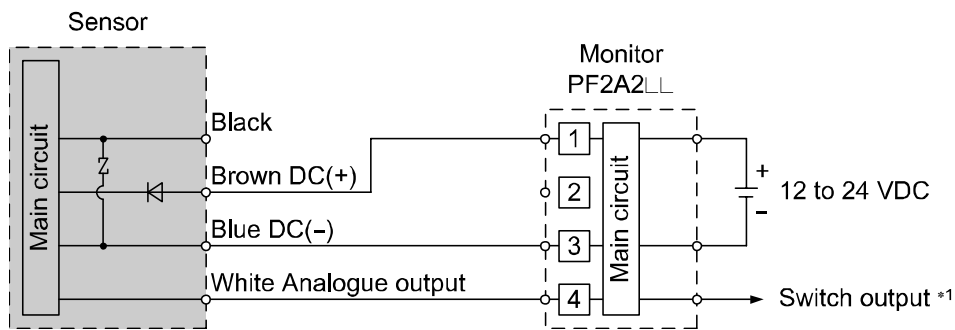
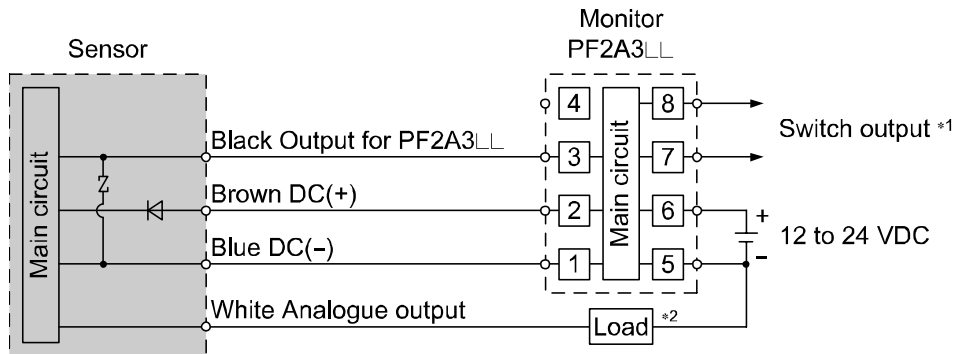

Analogue output: 1 to 5 V

Output impedance: 1 kΩ

*1: Refer to the PF2A3□□ or PF2A2□□ operation manual for details of the flow monitors.

*2: Load indicates analogue input equipment such as a voltmeter.

Output for PF2A3□□ + Analogue (4 to 20 mA) type

PF2A5□□-□□□□-2-□

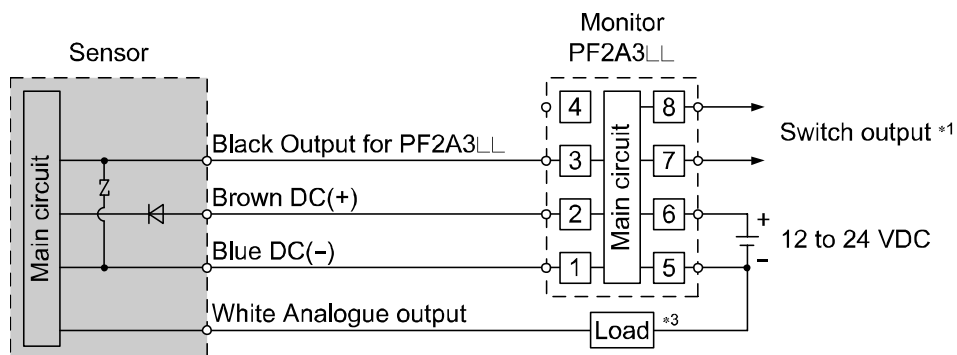

Analogue output: 4 to 20 mA

Load impedance: 300 Ω (12 VDC)

600 Ω (24 VDC)

*1: Refer to the PF2A3□□ operation manual for details of the flow monitor.

*3: Load indicates analogue input equipment such as an ammeter.

Troubleshooting

Troubleshooting

If an operation failure occurs with the product, use the chart below to find out the cause of the problem. If none of the countermeasures seem to be applicable, or a replacement product operates normally when installed, the product may be faulty. A product can be damaged by the operating environment (system configuration etc). If the product seems to be faulty, please contact SMC.

■ Cross-reference for troubleshooting

Fault		Probable cause	Recommended action
Output	There is no output.	Wiring failure.	Correct the wiring.
		Connector loose.	Check the connector.
	Output is unstable.	Foreign matter inside.	Install a filter or mist separator at IN side of product. If there is foreign matter stuck to the mesh, remove it completely, taking care not to damage the product.
		Piping is connected in the wrong direction.	Install with the mounting direction corresponding to the flow direction (arrow indicated on the product).
		Pulsation in the flow.	Change to a pump that has less pulsation. Install a tank to reduce the pressure fluctuation. Change the piping to elastic piping such as rubber tube.
		Air leakage.	Check that seal tape has been applied correctly. Reconnect the pipes with the specified tightening torque.

Specifications

■ Specifications

Model		PF2A510	PF2A550	PF2A511	PF2A521	PF2A551
Applicable fluid		Air and N ₂				
Fluid temperature		0 to 50 °C (no condensation or freezing)				
Flow	Rated flow range	1 to 10 L/min	5 to 50 L/min	10 to 100 L/min	20 to 200 L/min	50 to 500 L/min
	Rated pressure range	-50 kPa to 0.5 MPa		-50 kPa to 0.75 MPa		
Pressure	Proof pressure	1.0 MPa				
	Output for PF2A3□□	Analogue voltage output (non-linear), Output impedance: 1 kΩ				
Analogue output	Voltage output	1 to 5 V				
	Output impedance	1 kΩ				
	Current output	4 to 20 mA				
	Load impedance	Power supply voltage 12 V: 300 Ω Power supply voltage 24 V: 600 Ω				
	Accuracy *1	±5%F.S. max.				
	Repeatability *1	±1%F.S. max. (connected to PF2A3□□), ±3%F.S. max. (connected to PF2A2□□)				
Response time		1 s or less				
Supply voltage		12 to 24 VDC ±10%				
Power consumption (no load)		100 mA or less				110 mA or less
Environment	Enclosure	IP65				
	Operating temperature range	Operation: 0 to 50 °C, Storage: -25 to 85 °C (no condensation or freezing)				
	Operating humidity range	Operation, Storage: 35 to 85%R.H. (no condensation)				
	Temperature characteristics	±3%F.S. max. (15 to 35 °C, 25°C reference) ±5%F.S. max. (0 to 50 °C, 25°C reference)				
	Withstand voltage	1000 VAC, for 1 minute between the external terminals and case				
	Insulation resistance	50 MΩ or more (at 500 VDC) between external terminals and case				
Standards and regulations		CE, RoHS				
Port size (Rc, NPT, G)		1/8, 1/4		3/8		1/2
Materials of parts in contact with fluid		ADC, NBR, SUS, PBT, Lead glass, PtIr, FeNi, OFC				
Weight	Product *2	200 g		240 g		
	Lead wire and connector	100g				

*1: Total accuracy when used with applicable flow monitor.

*2: The product with analogue output is 20 g heavier.

Lead wire Specifications

Sheath	Finished outside diameter	approx. 4 mm
	Material	Oil-resistant PVC
Insulator	Colours	Brown, White, Black, Blue
	Outside diameter	approx. 1.14 mm
Conductor	Nominal cross section area	AWG23
	Outside diameter	approx. 0.72 mm

■ Characteristics data

● Flow characteristics (pressure loss)

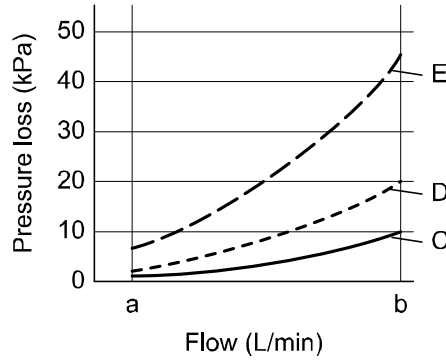
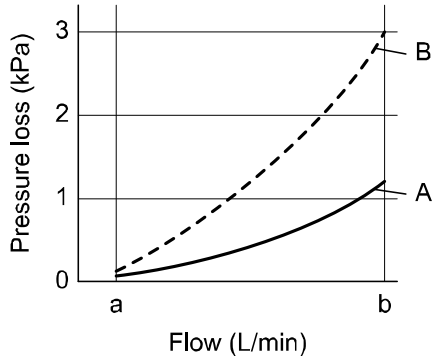

Model	Graph	a(L/min)	b(L/min)
PF2A510	A	1	10
PF2A550	B	5	50
PF2A511	C	10	100
PF2A521	D	20	200
PF2A551	E	50	500

● Analogue output

	A	B
Voltage output	1 V	5 V
Current output	4 mA	20 mA

Model	Rated flow range [L/min]	
	Min.	Max.
PF2A510	1	10
PF2A550	5	50
PF2A511	10	100
PF2A521	20	200
PF2A551	50	500

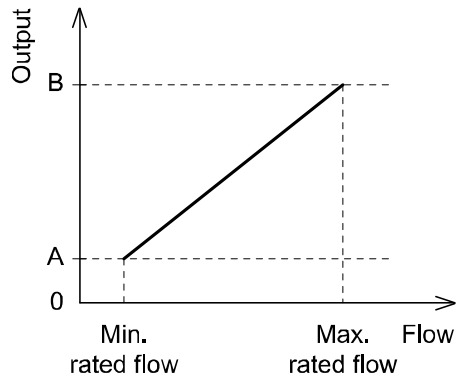

■ Dimensions (in mm)
PF2A510/550

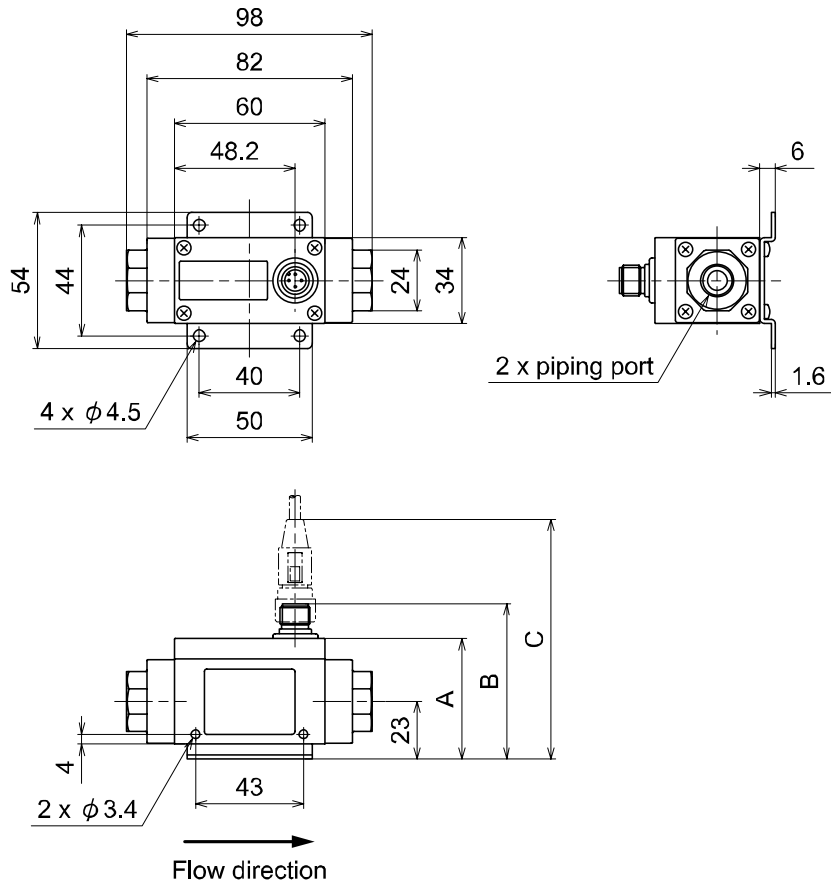

Output specifications	A	B	C
Output for PF2A3□□	48 mm	62 mm	94.3 mm
Output for PF2A3□□ + Analogue output	58 mm	72 mm	104.3 mm

PF2A511/521/551

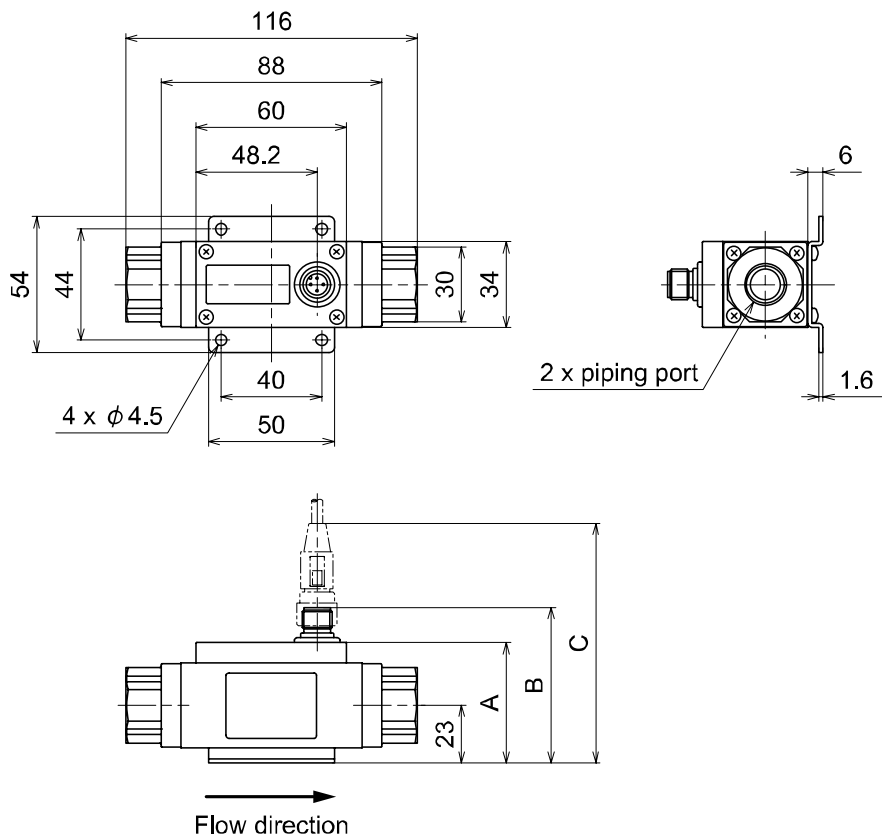

Output specifications	A	B	C
Output for PF2A3□□	48 mm	62 mm	94.3 mm
Output for PF2A3□□ + Analogue output	58 mm	72 mm	104.3 mm

Lead wire and connector (Straight): ZS-37-A

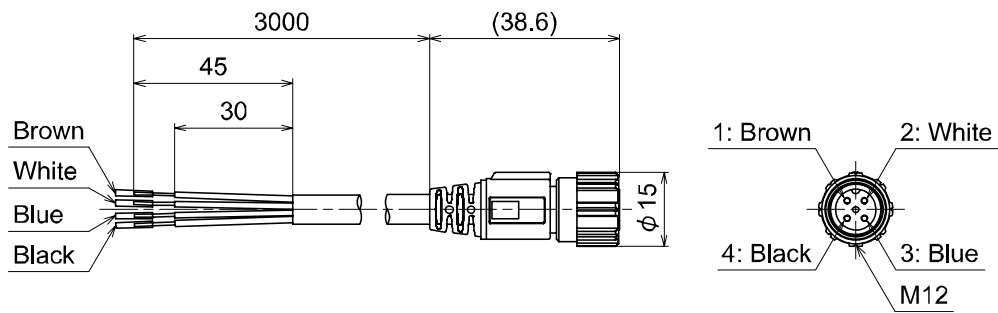

Lead wire and connector (Angle): ZS-37-B

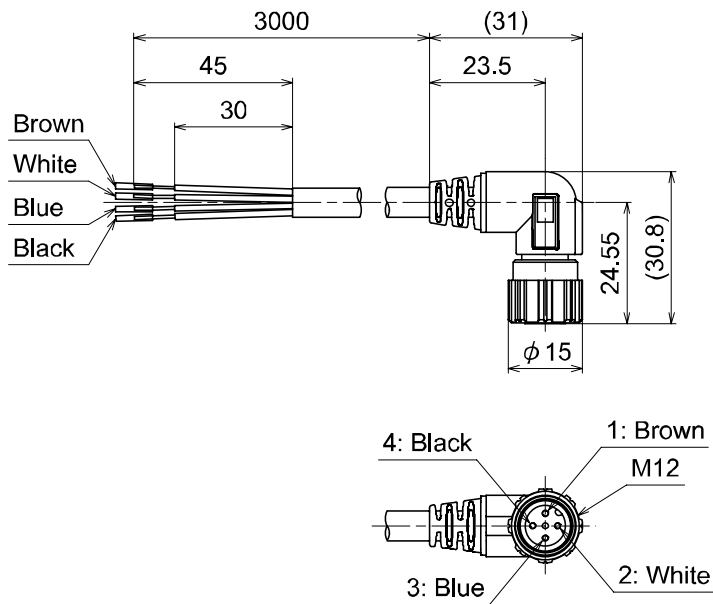

Bracket: ZS-29-T

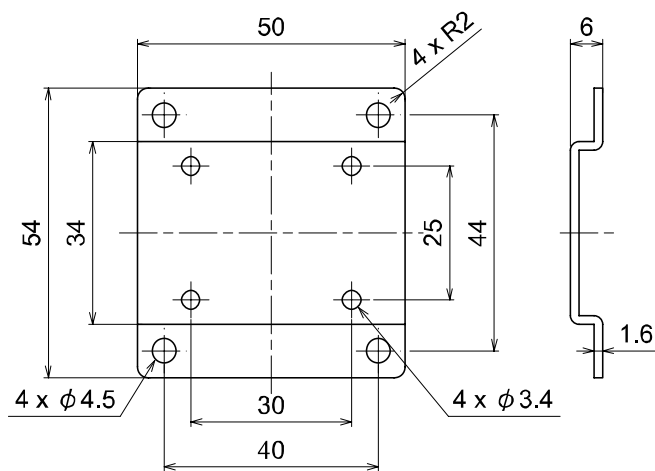

Revision history

SMC Corporation

4-14-1, Sotokanda, Chiyoda-ku, Tokyo 101-0021 JAPAN

Tel: +81 3 5207 8249 Fax: +81 3 5298 5362

URL <http://www.smcworld.com>

Note: Specifications are subject to change without prior notice and any obligation on the part of the manufacturer.
© 2011 SMC Corporation All Rights Reserved

