

---

# OPERATION MANUAL

---

SI Unit

---

EX140-SMJ1

---

---

---

---

---

---

---

---

---

---

## ● Safety Instructions ●

(Be sure to read before operation)

Thoroughly read this technical instruction manual and related manuals mentioned here to ensure the safety and proper operation of the product.

Level of potential hazard



**Warning** : Operator error could result in serious injury or loss of life.



**Caution** : Operator error could result in injury or equipment damage.



### Caution

- ① **Thoroughly read this manual before using.**  
Thoroughly read this manual and operate the product within the specified range following the instructions.
- ② **Handle with care.**  
Do not drop or give large impact to the product.
- ③ **Use within specified voltage range.**  
Using out of specified voltage will cause malfunction, damage of unit, electric shock, and fire.
- ④ **Do not touch terminal and internal circuit board while they are energized.**  
It may cause malfunction, damage of unit, and electric shock.
- ⑤ **Use within operating ambient temperature.**  
Do not use where temperature may rapidly change even though it is within the specifications.
- ⑥ **Foreign material should not be contained inside of the product.**  
Contamination of foreign material such as wire chips will cause fire, breakage, and malfunction.



### Warning

- ① **The product specified here is designed to use in ordinary full automation equipment.**  
Prevent the use in machinery and/or equipment where human life may be directly injured and malfunction or failure may cause enormous loss.
- ② **Do not disassemble.**  
Do not disassemble the product to repair and modify.

# CONTENTS

1. Outline .....	4
2. Applicable solenoid valve .....	4
3. Specifications.....	5
3 - 1 General specifications .....	5
3 - 2 CC-Link .....	6
3 - 3 SI Unit solenoid valve output .....	6
4. Descriptions & Functions .....	7
4 - 1 LED operation indicator .....	7
4 - 2 Transmission speed setting switch : "B RATE" .....	8
4 - 3 Station number setting switch : "STATION NO." .....	8
4 - 4 Terminal block for external wiring .....	8
5. Wiring method .....	9
5 - 1 Communication line .....	9
5 - 2 Power supply line .....	9
5-2-1 Power supply for communication .....	9
5-2-2 Power supply for solenoid valve .....	9
6. Rotary switch setting .....	10
6 - 1 Switch setting .....	10
6-1-1 Station number .....	10
6-1-2 Transmission speed .....	10
6 - 2 Parameter setting .....	11
7. Troubleshooting.....	12

## 1. Outline

### CC-Link System

#### ◆High speed communication

10 Mbps of high speed communication is possible. When 10 Mbps is set as the transmission speed, link scan time will be 4 ms even if 64 units are connected.

#### ◆A maximum of 64 SI units connectable.

In CC-Link, 64 remote I/O stations can be connected per master station at the maximum. Since one remote station contains 32 points, a maximum of 2048 points can be set as link points.

This SI unit occupies one station (16 output points) per unit. Thus, it is possible to set link points a maximum of 1024 points of valves.

#### ◆Variable communication speed / distance.

The option in speed and distance provides wide range of systems.

## 2. Applicable solenoid valve

SQ1000, 2000

SZ3000

### 3. Specifications

#### 3 - 1 General specifications

Supply voltage for communication	DC 15V to 30V
Supply voltage for solenoid valve	DC 24V $\begin{matrix} +10\% \\ -5\% \end{matrix}$
Power consumption	Communication, Internal power supply : DC 24V, 70mA or less Solenoid valve power supply : DC 24V, 1.5 A or less
Output number	16 points
Output type	Open collector type (NPN)
Connected load	DC 24V, SMC solenoid valve with 2.1 W or less of light/ surge voltage suppressor
Withstand voltage	Between external terminal package and ground, AC 1500V for 1 min.
Insulation resistance	Between all the live terminals and ground, 2M $\Omega$ ( with insulation resistance tester of DC 500V)
Noise resistance	$\pm$ 1500 Vp-p power supply noise, 1 $\mu$ s of pulse width for 3 min., 1ns pulse on first transition $\pm$ 1000 Vp-p radiation, 1 $\mu$ s of pulse width for 3 min., 1ns pulse on first transition
Vibration resistance	5 G (Compliance with JIS C0911, 10 to 55 Hz, 0.5 mm of one -side amplitude )
Shock resistance	10 G (Compliance with JIS C0912)
Ambient temperature	0 to + 55°C (when 8 points of valves are ON) 0 to + 50°C (when 16 points of valves are ON)
Ambient humidity	35 to 85 % RH (without dew condensation)
Environment	No corrosive gas
Storage temperature	- 10 to + 60 °C
Weight	80g or less

### 3 - 2 CC-Link

A

Max. link points	Remote I/O : 2048 points
Link points per station	Remote I/O : 32 points
Link scan time (at 10 Mbps)	3.9 ms / 64 stations (when all of them are equivalents of remote I/O stations)
Occupied station no.	1 station
Communication speed	10 M / 5M / 2.5M / 625K / 156 Kbps (changed by switch)
Communication type	Broad cast polling
Synchronization	Frame synchronization
Coding	NRZI
Transmission path	RS485 bus
Transmission format	Comply with HDLC
Error control	CRC ( $X^{16} + X^{12} + X^5 + 1$ )
Max. connectable unit number (for mater station)	64 units
Connection cable	Twist pair cable with shield
RAS function	Automatic line reset Confirmation of data link condition Offline test (hardware, line test, parameter confirmatory test)

This SI unit is designed to meet the specifications of remote I/O station. Refer to the Mitsubishi Electric Corp. CC-Link Users' Manual for details.

### 3 - 3 SI Unit solenoid valve output

Rated output current	100 mA / point or less
Residual voltage	0.4 V or less
Insulation	Photo coupler insulation
Output indication	Displayed with LEDs on manifold solenoid valve connected

## 4. Descriptions & Functions

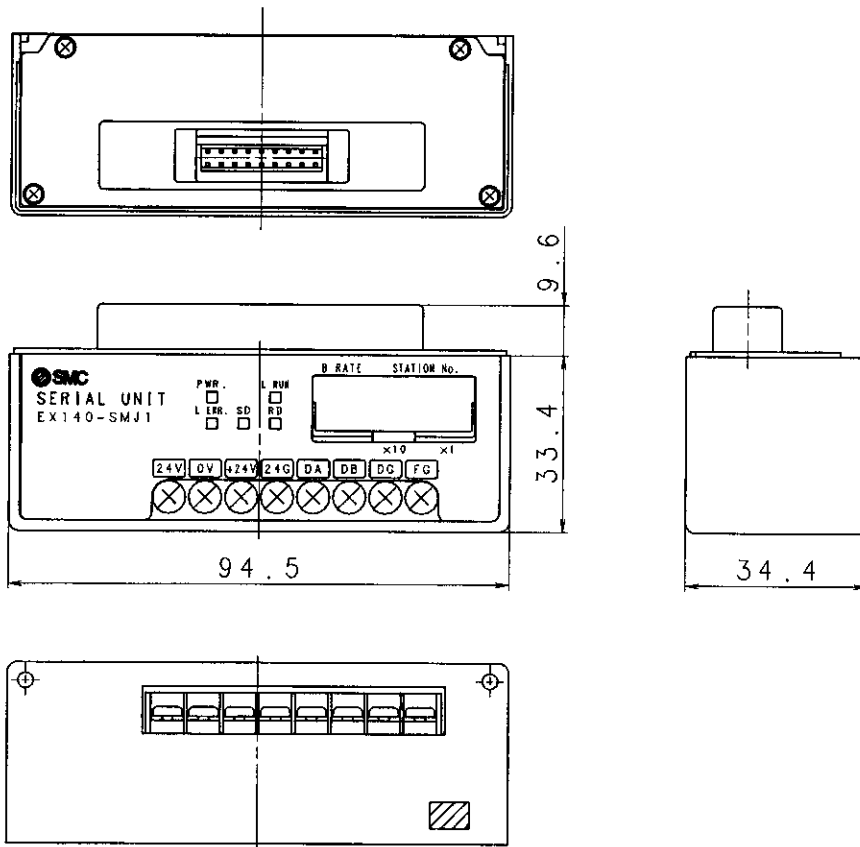

### 4 - 1 LED operation indicator

PW	Lights up as power supply for communication is turned on.
L RUN	To see whether if SI unit communicates data with master station normally. Goes off due to overtime lighting when receiving normal data from master station. (Lights up as receiving normal data.)
SD	Lights up as sending data.
RD	Lights up as receiving data.
L ERR.	Lights up when a transmission error (CRC error) occurs. Goes off due to overtime. (as well as RUN) Lights up if there is any error in station number setting or transmission speed setting. (Goes off when corrections are made and power is supplied again.) ERR blinks when setting of station number or transmission speed is changed. (RUN is lighting and the unit operates with a station number and transmission speed set at the first power supply.)

“PW”, “L RUN”, “SD” and “RD” light up when data linked normally.

#### 4 - 2 Transmission speed setting switch : “B RATE”

Setting	Transmission speed
0	156 kbps
1	625 kbps
2	2.5 Mbps
3	5 Mbps
4	10 Mbps

Set transmission speed within the range of 0 to 4, Refer to Chapter 6 for details.

#### 4 - 3 Station number setting switch : “STATION NO.”

Set station number within the range of 01 to 64. (Overlapped station number setting is not allowed.)

“×10” is to set the tens digit of a station number.

“× 1” is to set the units digit of a station number.

Refer to “Initial Setting”, Chapter 5 for details.

#### 4 - 4 Terminal block for external wiring

Terminal	Connect to
24 V	24 V of power supply line for solenoid valve
0 V	0 V of power supply line for solenoid valve
+ 24V	24 V of power supply line for communication
24 G	0 V of power supply line for communication
DA	Communication line DA
DB	Communication line DB
DG	Communication line DG
FG	Grounding conductor

\* M3 terminal threads in use.

## 5. Wiring method

### 5 - 1 Communication line

Connect master unit, local unit and remote unit (SI unit) using twist pair cables as follows.

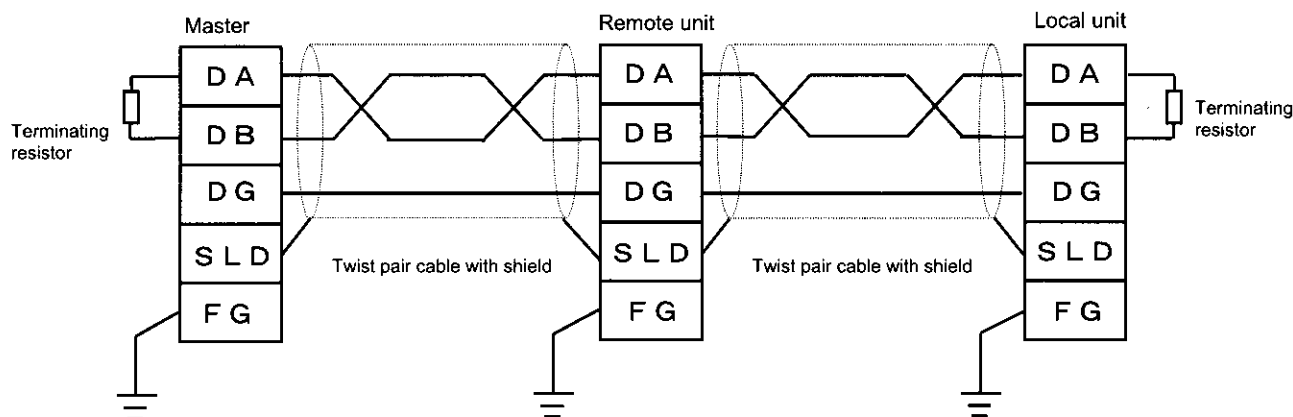

- (1) Connectable with any stations regardless of the station numbers.
- (2) Never fail to connect terminating resistor with "DA" and "DB" of each end unit.
- (3) Master unit can be connected with other than the ends of the cable.
- (4) Ground the both ends of a shielding wire of twist pair cable (Class 3 Grounding) via "FG" in a unit.
- (5) "SLD" and "FG" are common in this SI unit.

### 5 - 2 Power supply line

This SI unit has two power supply lines: for communication and solenoid valves.

#### 5-2-1 Power supply for communication

Connect with "+ 24V " and "24G".

+ 24V : 24V of power supply line for communication

24G : 0V of power supply line for communication

#### 5-2-2 Power supply for solenoid valve

Connect with "24V " and "0V".

24V : 24V of power supply line for solenoid valves

0V : 0V of power supply line for solenoid valves

Decide power supply and connection cable from the current consumption of solenoid valve and SI unit.

Power for solenoid valves can be transferred to SI unit power supply for communication.

## 6. Rotary switch setting

### 6 - 1 Switch setting

Set station numbers of SI unit while power is off.

Use rotary switches located in SI unit indication cover to set station numbers and communication speed.

- 1) Station number setting (01 to 64)
- 2) Communication speed setting (156 kbps, 625 kbps, 2.5 Mbps, 5 Mbps or 10 Mbps)

#### 6-1-1 Station number

Set station numbers of SI unit to determine a buffer memory address where to store output information of SI unit.

Conform them to the settings of "station information (address 20H to 5FH)" in parameter information area of buffer memory.

Set station numbers considering the following points.

- (1) Station number setting ranges from 01 to 64.
- (2) Only one station is occupied.
- (3) Any station number should not be skipped.

A skipped station number will be considered as an "abnormal data link station (link special register SW0080 to 0083 : buffer memory address 680H to 683H.)".

This can be avoided by setting a station to be skipped as a reserved station.

- (4) The same station number cannot be set repeatedly.

Otherwise, mounting error will occur. (Error code will be stored in SW0069.)

#### 6-1-2 Transmission speed

Possible transmission distance varies depending on the total extended distance.

Refer to the Mitsubishi Electric Corp. CC-Link Users' Manual for details.

Note: Clear mode is output when a communication error occurs.

## 6 - 2 Parameter setting

Among the necessary parameter setting for data link in CC-Link, station information setting is explained here.

For parameter setting, data is written in "parameter information area (address 0H to 5FH)" of master station buffer memory.

### Station information

Set the types of remote stations / local stations (or its equivalent) connected and set as a reserved station.

Conform them to the settings made by switches of SI unit indicator.

The structure of data to be set is shown below.

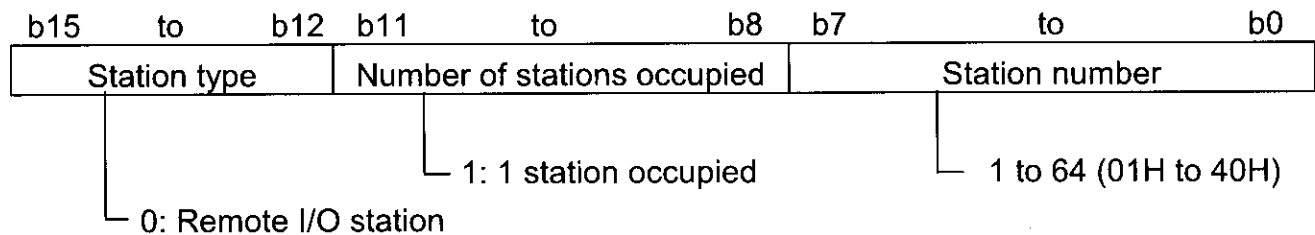

It comes to "0 1 \* \*". (\* \*: 1 to 64)

## 7. Troubleshooting

Follow the chart below to take some measures against SI unit malfunctions.

Refer to the Users' Manual prepared by Mitsubishi Electric Corp. when the whole system needs troubleshooting.

