OPERATION MANUAL

SI unit

EX250-SDN1

Contents

1.Precautions	-----	P2
2.Specifications		
2-1.General specification	-----	P5
2-2.Electrical and network	-----	P5
2-3.Applicable solenoid valve series	-----	P6
3.Wiring and setting		
3-1.Connection type	-----	P6
3-2.Wiring of power supply	-----	P8
3-3.Installation and maintenance	-----	P10
3-4.Address setting	-----	P12
4.LED indicator and Physical dimensions		
4-1.LED indication	-----	P14
4-2.Physical dimensions	-----	P15
5.Trouble Shooting	-----	P16

1. Precaution

Following safety requirements aim at the prevention of hazardous condition and the damage of instruments. Here, the hazard is classified in “Dangerous”, “Warning” and “Caution” on the level of hazard.

Please refer to regulation of safety on ISO and JIS to ensure safety.



Warning : Operator error may cause the death or serious injury.



Caution : Operator error may cause the injury or equipment damage.



Warning

- 1.The product is designed to use in ordinary full automation equipment. Don't use this product in equipment or instrument where human life may be directly injured or malfunction of failure may cause devastating loss.
- 2.Don't disassemble the product to repair and modification.



Caution

Read this operation manual carefully to ensure the safety and proper operation.

Design, Selection

1. See the specification

Keep all requirements in the specification (Voltage, operating ambient temperature, impact) to avoid damage, malfunction and fire.

2. Specified maintenance space is necessary

Design must consider the space necessary for maintenance.

Installation, Adjustment, Wiring

1. Don't drop nor hit the unit

Don't apply impact more than 100m/s². Internal parts of SI unit may be damaged and malfunction.

2. Wire properly

SI unit may damage by improper wiring.

3. Don't wire power supply line and high power line together

Wire SI unit wiring (piping) and power line/high power line separately to avoid interference of noise and surge from high power line to the signal line.

4. Ensure the insulation of wiring

Insulation failure (mixture with other circuit, insulation between terminals etc.) may cause excessive voltage or current to SI unit which leads to damage the SI unit.

5. Keep the tightening torque

The screw should be tighten with the specified torque, otherwise IP67 protection can not be guaranteed.

6. Don't apply repeated bend and tensile force

Wiring applying repeated bending stress and tensile force lead to cause disconnection.

Operating Condition

1. Never use in explosive environment

SI unit is not explosion proof. Operation in explosive environment may cause explosion accident.

2. Don't apply temperature cycle

Temperature cycle other than normal temperature change do harm to the internal part of SI unit.

3. Don't use where exposed to surge source

Device and instrument which generate big surge (Electromagnetic lifter, High frequency induction furnace, motor etc.) adjacent to the manifold solenoid valve with SI unit lead to cause the deterioration or damage of the switch internal circuit element. Consider the solution against surge and do not to mix lines.

4. Bits of wire and other foreign materials should not enter the product

Bits of wire and other foreign materials in SI unit may cause fire, failure or malfunction.

5. Mounting of SI unit on manifold and wiring from the conduit shall be treated as specified

Otherwise IP67 rating cannot be attained.

Maintenance

1. Periodic maintenance is recommended to avoid unexpected failure and malfunction.

2. Don't touch the terminal and internal board during energization to avoid malfunction, unit damage, and electric shock.

Safety instructions for power supply

1. User must supply power to input and solenoid separately single or dual power supplies can be used.
2. Choose UL recognized product for direct current power source to be mounted.

(1) Limited voltage current circuit complying with UL508

The power supply circuit made with secondary side coil of isolation transformer which satisfies the following condition

- Max. voltage (No load applied) : 30Vrms (42.4V peak) or less, and
- Max. current : 8A or less (Include when short), and restricted by the circuit protecting device (fuse) with rate in the table below

Voltage with no load (V peak)	Max. current rate
0 to 20 [V]	5.0
Exceeding 20 [V] up to 30 [V]	$\frac{100}{\text{Peak voltage}}$

- (2) Max. 30Vrms (42.4V peak) or less circuit (Class 2 circuit) which sources class 2 source unit complying with UL1310 or class 2 transformer complying with UL1585.

2. Specifications

2-1 General specification

Item	Specification
Operating ambient temp.	+5 to +45°C
Operating ambient humidity	35 to 85% RH (No dew condensation)
Storage ambient temp.	-20 to +60°C
Vibration proof	10 to 57Hz 0.35mm (Constant amplitude) 57 to 150Hz 50m/s ² (Constant acceleration)
Impact proof	150m/s ² (peak), 11ms × three times in each direction ± X, Y and Z.
Noise immunity	Normal mode : ±1500V Pulse duration 1us Common mode : ±1500V Pulse duration 1us Radiation : ±1000V Pulse duration 1us
Withstand voltage	500V AC for 1min.
Insulation resistance	500V DC min10M ohm
Operating environment	No corrosive gas and no dust

2-2 Electrical and network

Item		Specification
Applicable system		DeviceNet Release 2.0
Power voltage range Current consumption	Power for SI unit Current consumption	11 to 25V DC 100mA or less
	Power for Input Block Current consumption	19.2 to 28.8V DC Depending on the number of Input Block stations and sensor specifications. Max 1A or less
	Power for solenoid valve Current consumption	21.6 to 26.4V DC (Power reduction alarm occurs at approx. 19V DC.) Depending on number of Solenoid valve station and specifications Max 2.5A or less
Solenoid valve connection spec.	Output type	P-ch MOS-FET Open drain type
	Connection load	Solenoid valve with protection circuit for 24V DC and 1.5W or less surge voltage. (made by SMC)
	Insulation type	Opto coupler type
Residual voltage		0.3V DC or less
Network connection spec.	MAC ID setting range	0 to 63 (Set by DIP / retain address information when setting power is shut off via network.)
	Baud Rate (Transmission speed)	500kbps, 250kbps, 125kbps (Set by DIP / hold address information when setting power is shut off via network.)
	Slave (branch station) type	Group 2 only server
	Connection type	T branch type, Multi drop type
	Device type	27
	Product code	2401
	Revision	Refer to EDS file
	Vendor ID	7
	Consumed connection size (Receiving bite)	4 (Polled I/O connection : Occupy 4 byte)
	Produced connection size (Sending bite)	4 (Polled I/O connection : Occupy 4 byte)
Correspond message		Polled command (I/O message), Explicit message.

SI unit I/O data (Poll command sending / receiving data)

Item		Output (Poll request)	Input (Poll response)
Occupied bite		4 byte (Solenoid valve output)	4 byte (Sensor input)
Sending / receiving data	Address + 0	Output No. 0 to 7	Input No.0 to 7
	Address + 1	Output No. 8 to 15	Input No.8 to 15
	Address + 2	Output No. 16 to 23	Input No.16 to 23
	Address + 3	Output No. 24 to 31	Input No.24 to 31

*) Mapping method of sending / receiving data is different by PLC.

For further information, refer to the manual for PLC master (scanner)

2-3 Applicable solenoid valve series

Valve type	Valve series
VQC series	VQC1000, VQC2000
SV series	SV1000, SV2000, SV3000

3. Wiring and Setting

3-1 Connection type

DeviceNet can be connected by T branch, Multi branch, Stay branch and Multi drop. Total extension length of trunk and Stay is different for different Baud rate and thickness of communication cable.

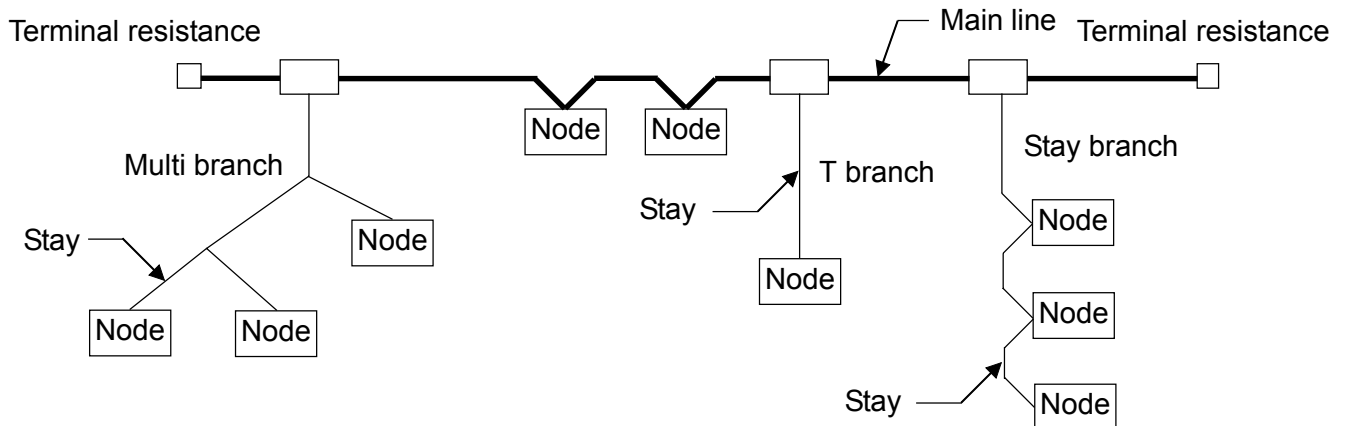

Length of wiring

Communication distance	Baud rate	Total length of trunk	Length of stay	Total length of stay
Thick cable	500 kbps	100m or less	6m or less	39m or less
	250 kbps	250m or less		78m or less
	125 kbps	500m or less		156m or less
Thin cable	Common	100m or less		
Terminal resistance	121 ohm (1/2W)			

Cable specification

Item	Thick cable		Thin cable	
	Communication Signal	Power supply	Communication Signal	Power supply
Conductor cross section	0.82 mm ²	1.65 mm ²	0.20 mm ²	0.33 mm ²
Colors	Blue, White	Red, Black	Blue, White	Red, Black
Impedance	120ohm±10%(1MHz)	—	120ohm±10%(1MHz)	—
Propagation delay	1.36ns / ft(max)	—	1.36ns / ft(max)	—
Attenuation rate	0.13db/100ft@125KHz(max) 0.25db/100ft@500KHz(max) 0.36db/100ft@1.00MHz(max)	—	0.29db/100ft@125KHz(max) 0.50db/100ft@500KHz(max) 0.70db/100ft@1.00MHz(max)	—
Conductor resistance	6.9ohm / 1000ft(max)	3.6ohm / 1000ft(max)	28ohm / 1000ft(max)	17.5ohm / 1000ft(max)

⚠ Caution on wiring

For Multi drop connection, prepare plug connector for T branch separately.

Use DeviceNet special cable for communication cable.

Be sure to connect DeviceNet special terminal resistor with both ends of trunk.

Example of connection

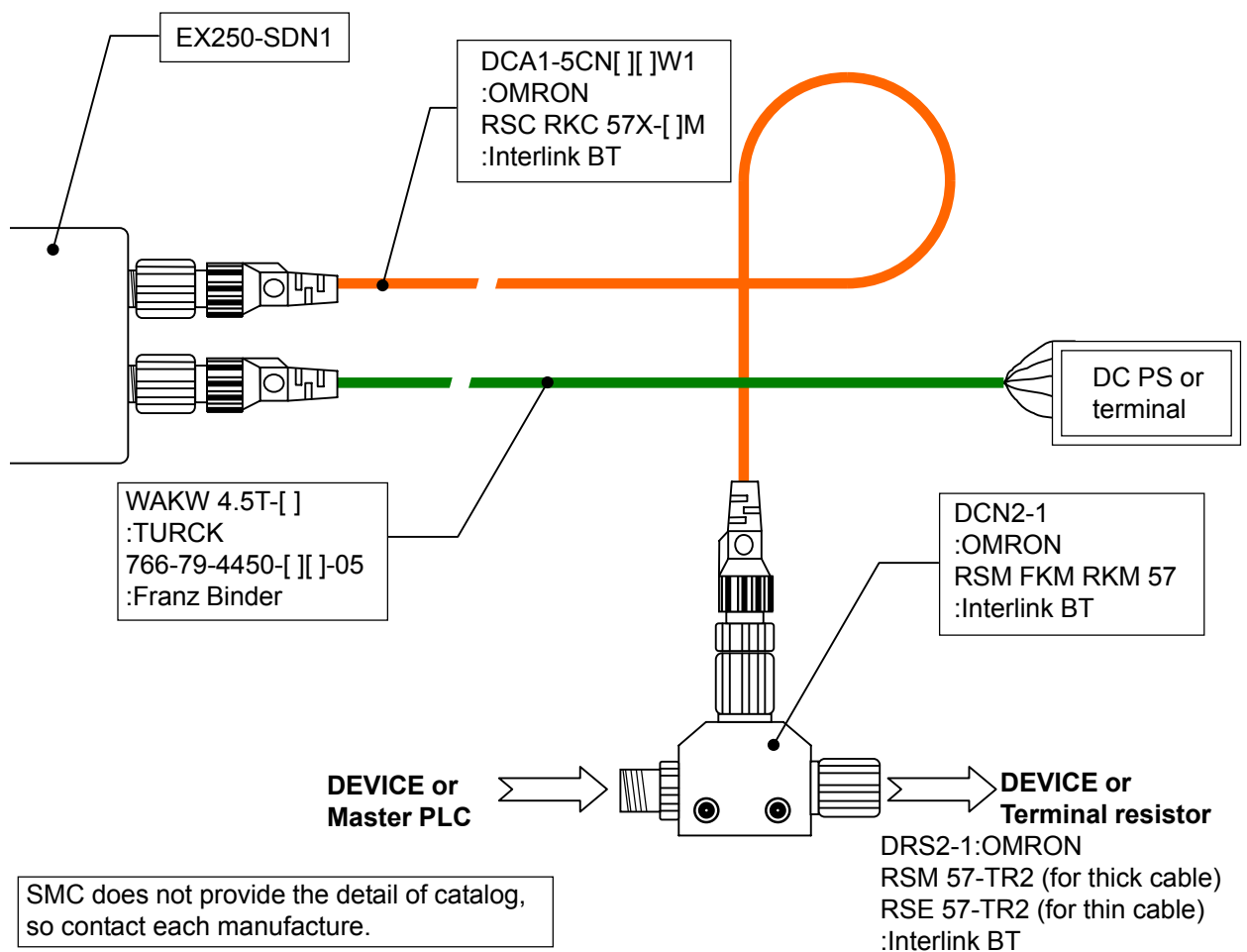

3-2 Wiring of power supply

Power supply line inside the unit has individual power supplies for solenoid valve actuation (SV power supply) and for Sensor (SW power supply). Supply 24V DC for each of them.

Either single or dual power supply is available. Wiring is not necessary for SW power supply when Input Block is not used.

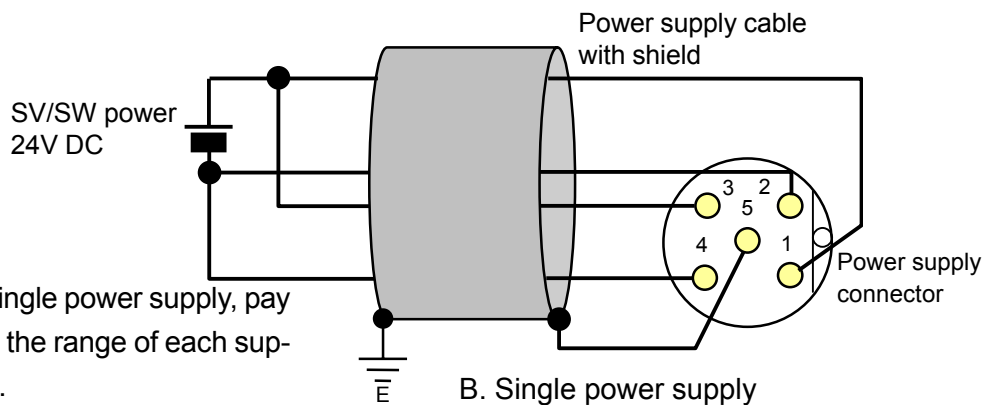
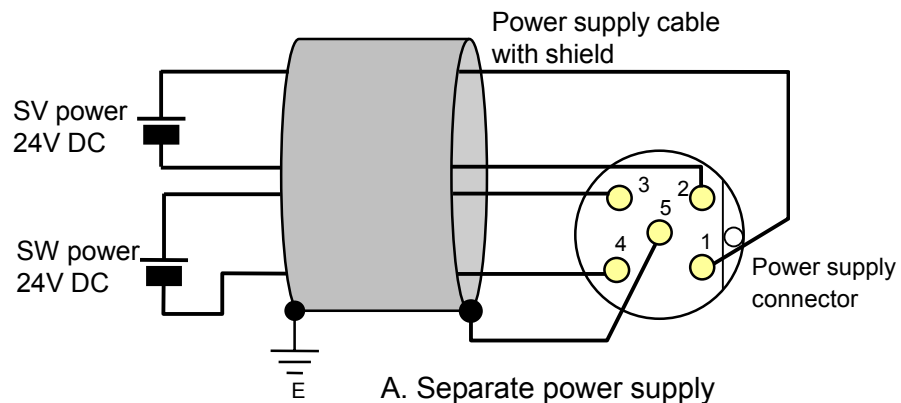

*In case of single power supply, pay attention to the range of each supply voltage.

Power for sensor is supplied to sensor connected with Input Block. Select sensor concerning voltage drop up to approx. 1V inside the unit at this moment.

If sensor requires 24V, it is necessary to lower power supply voltage for sensor slightly or secure power supply for sensor separately without going through SI unit so that sensor input voltage can be 24V with actual loading (allowable voltage of sensor power supply : 19.2V to 28.8V).

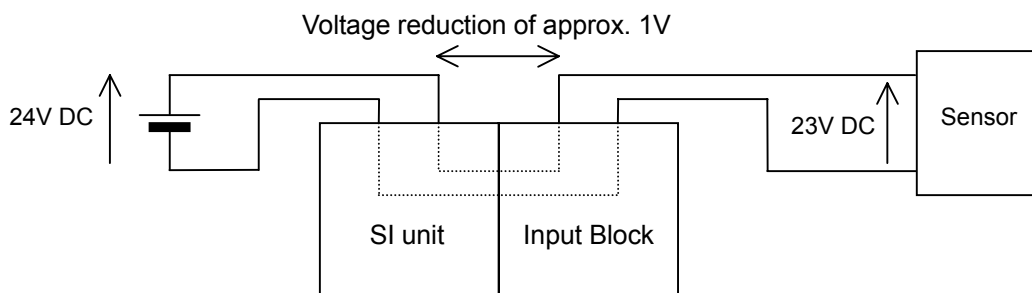

Power supply connector

M12 5pin (Plug)

Example of connector on cable side : Ex.TURCK WAKW 4.5T-[] etc.

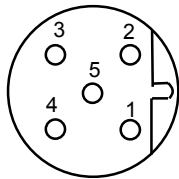

No.	Description	Function
1	SV 24V	For solenoid valve +24V
2	SV 0V	For solenoid valve 0V
3	SW 24V	For sensor unit +24V
4	SW 0V	For sensor unit 0V
5	E	Earth

Communication connector

M12 5pin (Plug) [Special for DeviceNet]

Example of connector on cable side : Ex.OMRON DCA1-5CN[][]F1
KARL LUMBERG RKT5-56
Interlink BT RSC RKC 57X-[]M etc.

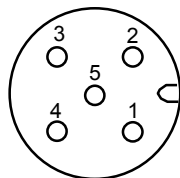

No.	Description	Function
1	Drain	Drain / Shield
2	V +	Power supply + for circuit
3	V -	Power supply - for circuit
4	CAN_H	Signal wire H
5	CAN_L	Signal wire L

Applicable to Micro Style connector with DeviceNet specification

3-3 Installation and maintenance

Installation size

- SI unit does not have mounting holes.
- The unit can not be installed by itself.
- Solenoid valve manifold must be attached with SI unit.
- If no Input Block is required, then the End Plate must be attached with SI unit.

Example of installation

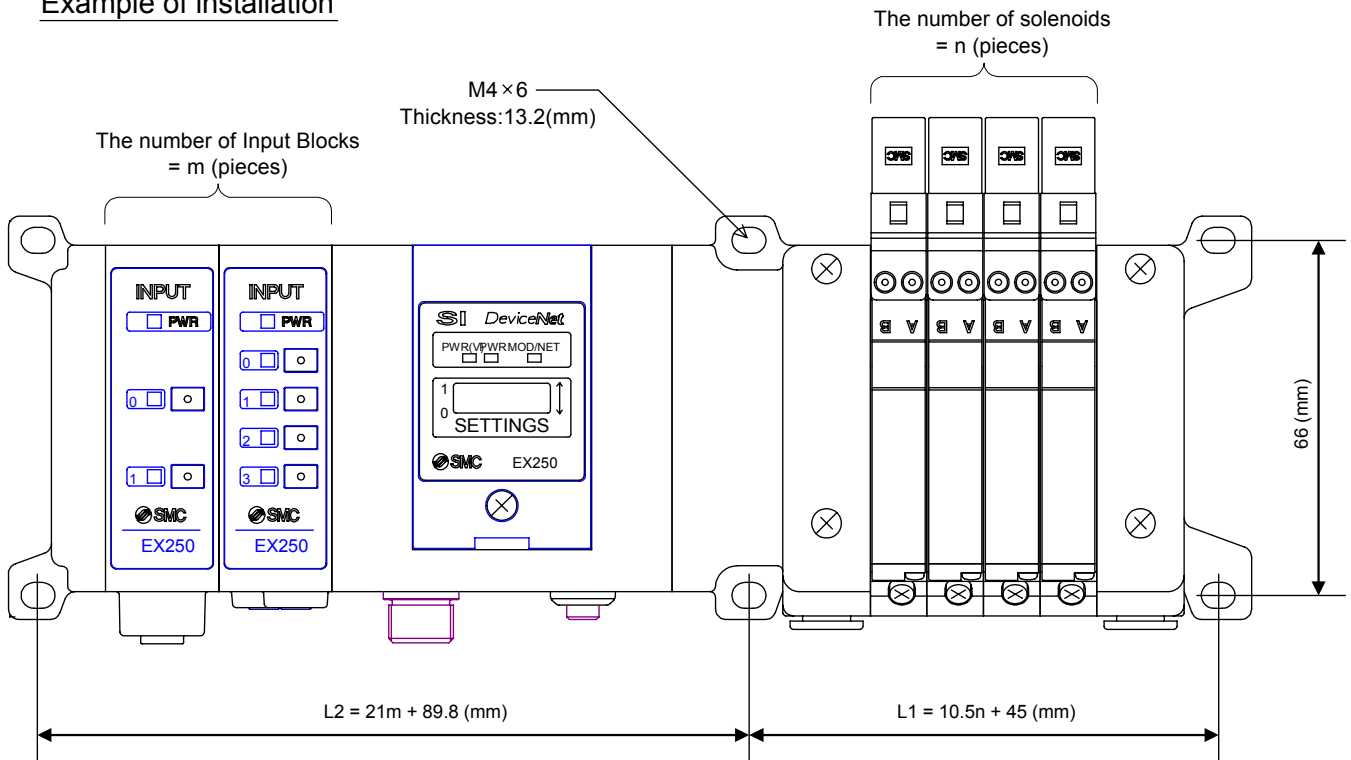

L \ n_m	0	1	2	3	4	5	6	7	8	9	10	11	12	13	14	15	16
L1	45.0	55.5	66.0	76.5	87.0	97.5	108.0	118.5	129.0	139.5	150.0	160.5	171.0	181.5	192.0	202.5	213.0
L2	89.8	110.8	131.8	152.8	173.8	194.8	215.8	236.8	257.8	278.8	299.8	320.8	341.8	362.8	383.8	404.8	425.8

Note : Dimensions of L1 are shown for VQC1000 solenoid valve series.

Refer to SMC catalogue for valve series.

Wiring (for power supply, communication and input) and piping are done on only one side.
On the side, make a space for wiring and piping.

Maintenance

Addition of Input Block

1. Remove screws from End Plate.
2. Mount attached tie rod.
3. Connect additional Input Block.
4. Connect End Plate and tighten removed screws by specified tightening torque. (0.6N·m)

Exchange of SI unit

1. Remove screws from End Plate and release connection of each unit.
2. Replace old SI unit with new one. (Tie rod does not need to be removed.)
3. Connect End Plate and tighten removed screws by specified tightening torque. (0.6N·m)

Caution for maintenance

- (1) Be sure to turn-off all power supplies.
- (2) Be sure that there is no foreign object in any of units.
- (3) Be sure that gasket is lined properly.
- (4) Be sure that tightening torque is according to specification.

If these items are not kept, it may lead to the breakage of substrate or intrusion of liquid or dust into the units.

Assembly and disconnection of unit

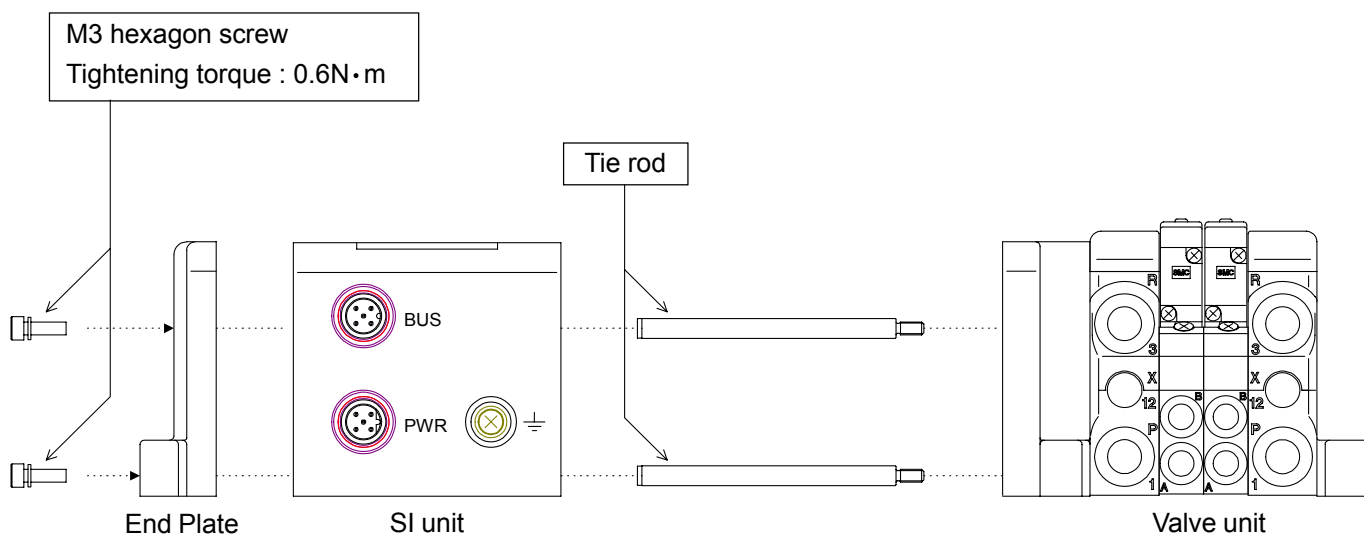

3-4 Address setting

When DIP switch is set, turn power supply of SI unit to OFF.

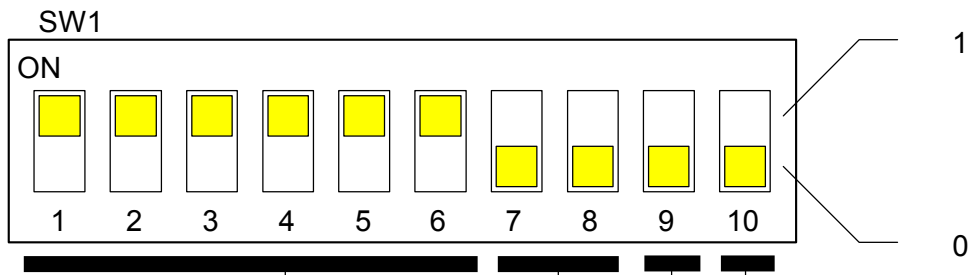

Setting of address

Address	SW1-1	SW1-2	SW1-3	SW1-4	SW1-5	SW1-6
	2^0 (1)	2^1 (2)	2^2 (4)	2^3 (8)	2^4 (16)	2^5 (32)
0	0	0	0	0	0	0
1	1	0	0	0	0	0
2	0	1	0	0	0	0
:						
62	0	1	1	1	1	1
63	1	1	1	1	1	1

Setting of Baud rate

Baud rate	SW1-7	SW1-8
125 kbps	0	0
250 kbps	1	0
500 kbps	0	1
Not used	1	1

Setting of solenoid output state in communication fault

Solenoid output state : Communication stops (IO connection time out) or fault message is received.

SW1-9	Solenoid output state	
1	HOLD	All solenoid valve outputs are hold before communication fault. (Fault state=1·Fault value=0)
0	CLEAR	All solenoid outputs are reset to zero. (Fault state=0·Fault value=0)

Mode setting

SW1-10	Mode
0	H/W mode
	Set address and Baud rate by SW1-1 to 8
1	S/W mode
	Set address and Baud rate by network. SW1-1 to 8 are invalid.

Position of DIP switch

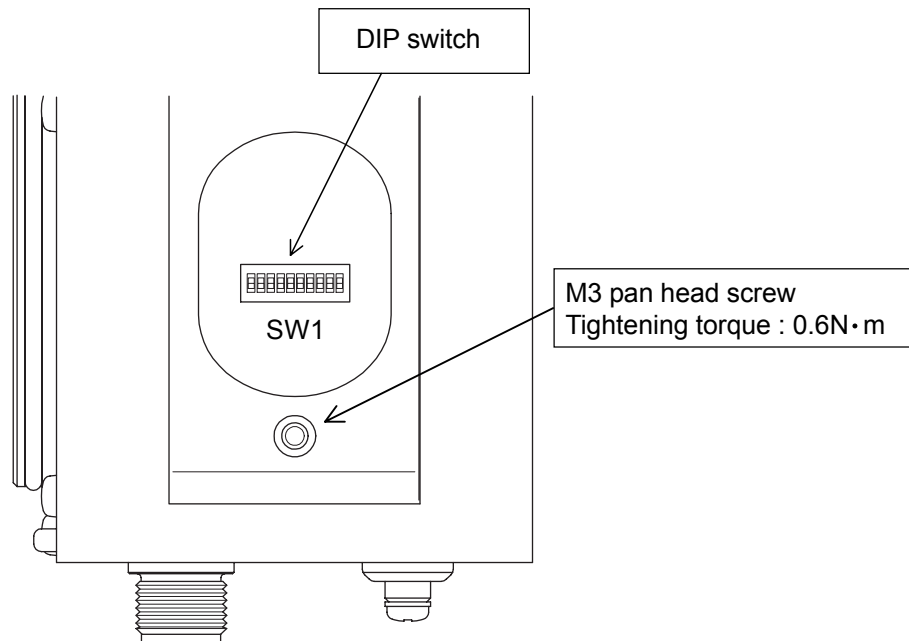

Caution

1. Default value of address and baud rate.

Node address and baud rate are preset to 63, 125kbps respectively at the shipment in either H/W mode or S/W mode.

2. In S/W mode, setting value of address and baud rate are retained even after power supply is off.
3. In H/W mode, once power supply is turned off and turned on again, then setting value of address and baud rate in S/W mode are erased.

Address and baud rate can be newly set by setting switch SW1.

Example

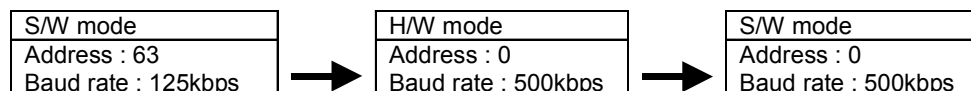

4. Output with communication stopped is set to 0 (full output clear mode) at shipment from factory. It is possible to change setting of single output when communication stopped. In this case, setting of SW1-9 gets invalid.

4.LED indicator and Physical dimensions

4-1 LED indication

SI unit (EX250-SDN1)

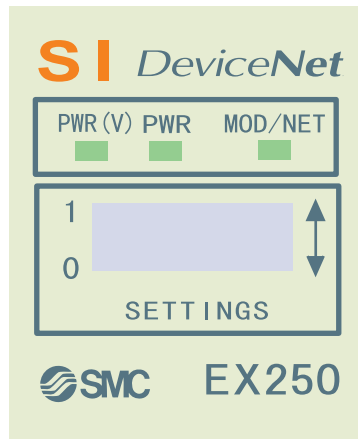

Indication	Contents	
PWR (V)	Lights up when power for solenoid valve is supplied.	
PWR	Lights up when power for DeviceNet line is supplied.	
MOD / NET	Lights off	Power off, off line or Duplicate MAC ID.
	Green flashing	Waiting for connection (ON line)
	Green lights up	Connection completed (ON line)
	Red flashing	Connection time out (Minor communication error)
	Red lights up	MAC ID duplication error or BUS OFF error (Major communication error)

4-2 Physical dimensions

SI unit (EX250-SDN1)

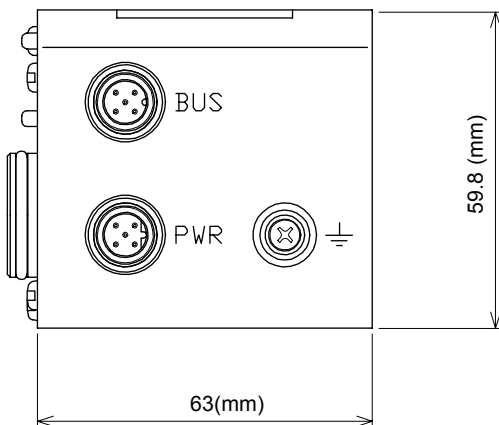
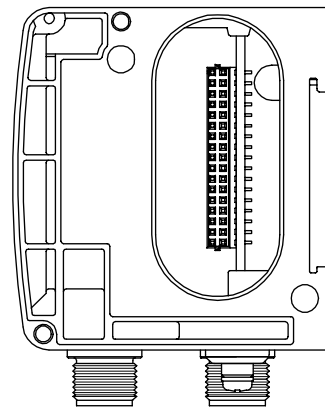
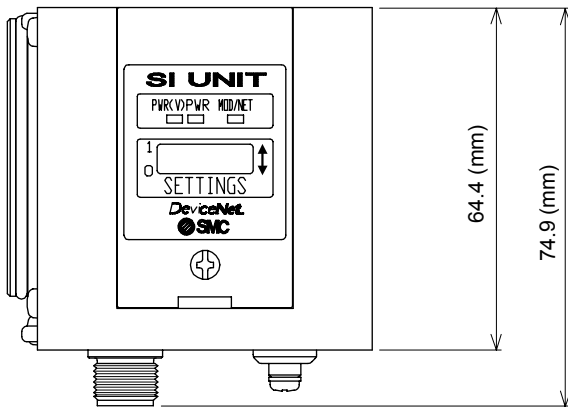
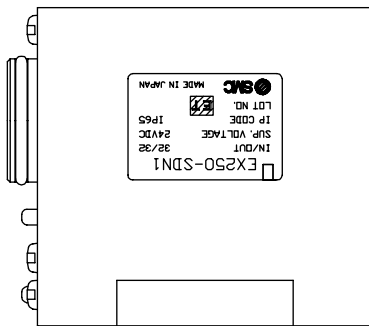

5. Trouble Shooting

MOD/NET LED	Cause & Countermeasure
Lights off	<p><u>PWR LED lights off</u> <Countermeasure> Confirm that power for SI unit circuit is supplied. Confirm correct wiring for circuit. If above countermeasures do not improve status, please exchange SI unit.</p> <p><u>PWR LED lights up</u> <Countermeasure> Confirm that baud rate is set correctly. If MOD/NET LED lights off in spite of baud rate is set correctly, change SI unit.</p>
Green flashing	<p><u>Connection waiting</u> Shows communication waiting status between SI unit and master. <Countermeasure> Confirm master operate correctly. If using scan list, ensure slave is recorded to scan list correctly.</p>
Red flashing	<p><u>Communication wire disconnected error</u> <u>Warning for SV supply voltage drop</u> <Countermeasure> Confirm communication wire is not disconnected. Confirm SV power supply voltage is according to specification. (21.6 to 26.4V) <Remark> Red flashing if master power source is turned off during communication.</p>
Red lights up	<p><u>Node address overlapping error</u> <Countermeasure> Confirm there is no overlapping on the node address.</p> <p><u>BUS OFF error</u> Detects communication error. <Countermeasure></p> <p><u>Case 1</u> Communication error due to noise. Confirm there is no component or high voltage cable that generate noise around communication wire. Make some distances between communication wire and noise source.</p> <p><u>Case2</u> Communication cable problem Confirm terminal resistance (121ohm) connects to the both ends of communication wire that is main wire of communication wire.</p> <p>If red MOD/NET LED is still lights up in spite of above countermeasures, change SI unit.</p>

Caution

When red MOD/NET LED is lit, even if cause is solved, SI unit do not do auto-recovery. In this case, please reset the power to SI unit circuit (Communication/Internal power supply).