

TEMPORARY

TECHNICAL INSTRUCTION MANUAL For EX500 SERIAL SYSTEM

EX500 - GMJ1 corresponds with CC - Link.

Gateway (GW) Unit	:	EX500 - GMJ1
-------------------	---	--------------

Input Unit Manifold

Input Manifold	:	EEX500 - IB1 - □□
----------------	---	-------------------

Input Unit	:	EX500 - IB1
------------	---	-------------

M8 Input Block (PNP)	:	EX500 - IE1
------------------------	---	-------------

M8 Input Block (NPN)	:	EX500 - IE2
------------------------	---	-------------

M12 Input Block (PNP)	:	EX500 - IE3
-------------------------	---	-------------

M12 Input Block (NPN)	:	EX500 - IE4
-------------------------	---	-------------

SI Unit

SV series	:	EX500 - S001
-----------	---	--------------

VQC series (NPN)	:	EX500 - Q001
------------------	---	--------------

VQC series (PNP)	:	EX500 - Q101
------------------	---	--------------



● Safety Instructions ●

(Read carefully before handling.)

Thoroughly read this handling manual and related manuals mentioned here to ensure the safety and proper operation of the product.

These safety instructions are intended to prevent hazardous situations and / or equipment damage. These instructions indicate the level of potential hazard by labeling “ **CAUTION** ” or “ **WARNING** ” .

•Level of potential hazard

-  **CAUTION** : Operator error could result in injury or equipment damage.
-  **WARNING** : Operator error could result in serious injury or loss of life .

•Safety instructions for pneumatic equipment



- 1. The compatibility of pneumatic equipment is the responsibility of the person who designs the pneumatic system or decides its specifications.**
Since the products specified here are used in various operating conditions, their compatibility with the specific pneumatic system must be based on specifications or after analysis and / or tests to meet your specific requirements.
- 2. Only trained personnel should operate pneumatically operated machinery and equipment.**
Compressed air can be dangerous if an operator is unfamiliar with it.
Assembly, handling or repair of pneumatic systems should be performed by trained and experienced operators.
- 3. Do not service machinery / equipment or attempt to remove components until safety is confirmed.**
 1. Inspection and maintenance of machinery / equipment should only be performed after confirmation of safe locked-out control positions.
 2. When equipment is to be removed, confirm the safety process as mentioned above.
Cut the supply pressure for the equipment and exhaust all residual compressed air in the system.
 3. Before machinery / equipment is re-started, take measures to prevent quick extensions of the cylinder piston rod etc. (Bleed air into the system gradually to create back-pressure.)
- 4. Contact SMC if the product is to be used in any of the following conditions:**
 1. Conditions and environments beyond the given specifications, or if product is used outdoors.
 2. Installation on equipment in conjunction with atomic energy, railway, air navigation, vehicles, medical equipment, food and beverage, recreation equipment, emergency stop circuits, press applications, or safety equipment.
 3. An application which has the possibility of having negative effects on people, property, or animals, requiring special safety analysis.

•Safety instructions for electric equipment



1. The product specified here is designed to use in ordinary factory automation equipment.
Prevent the use in machinery and / or equipment where human life may be directly injured and malfunction or failure may cause enormous loss.
2. Don't use in the explosive atmosphere, the atmosphere of flammable gas, the corrosive atmosphere.
It becomes cause such as the injury, the fire.
3. The person who has professional knowledge implement work of the carriage, the establishment, the piping, the wiring, the operation, the handling, the maintenance, the check.
If not, it will cause in being shocked, the injury, the fire and so on.
4. Install a direct stop circuit outside that to stop operation immediately and then to shut the power supply.
5. Do not disassemble the product for modifications.
It will cause in the injury, the damaging and so on.
6. Don't wipe a product with the chemical medicine and so on.

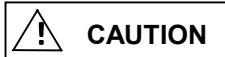

1. Read this manual adequately, and operate the product within the range of the specification after observing notes strictly.
2. Do not drop or give any impact to the product.
It will cause in being the damage to unit, the failure, the malfunction and so on.
3. Take appropriate measures to ensure that the specified power is supplied regardless of the condition of power supply.
Use within specified voltage range. To use outside of specified voltage will cause malfunction, damage to unit, electric shock, and fire.
4. Do not touch the terminal or internal circuit board while they are energized.
If not, it will cause malfunction, damage to unit, and electric shock.
Turn the power supply OFF when increasing / decreasing of the Input Block or the Manifold Valve and pulling out of the connector.
5. Use within operating ambient temperature. Do not use where temperatures can rapidly change even though it is within the specifications.
6. Foreign objects should be prevented from entering the product. Contamination by foreign objects, such as wire chips will cause fire, breakage, and malfunction.
7. Use within the operating environment of the protection structure.
IP65 is achieved by proper mounting of Input Unit / Input Block and Manifold Valve with SI Unit and by processing properly a cable with the M12 connector which is wiring each unit, and a cable which is wiring for power supply, and a connector which is setting for communication, and by processing properly with the water - proof cap when there is an unused port.
Take measures such as the covers to use in the environment to which water splashes always.
8. Operate within the specified tightening torque.
It will be possible to damage the screw when the screw is tightened exceeding the range of the tightening torque.
9. Take appropriate and sufficient countermeasures when installing systems in the following locations.
 - Locations subject to static electricity or other forms of noise.
 - Locations subject to strong electromagnetic fields.
 - Locations subject to possible exposure to radioactivity.
 - Locations close to power supplies.
10. Take appropriate measures to noise such as the noise filter and so on when installing this product in equipment.
11. This product is a component, which is installed in the final equipment and used. Please confirm the adaptability of EMC instruction when being installed in equipment by the customer.
12. Do not detach the nameplate.
13. Carry out periodical checks to confirm correct operation.
Safety may not be maintained by unintentional malfunction or incorrect operation.

-Safety instructions for cables

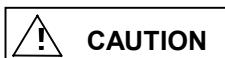

1. Pay attention wrong wiring.
It will cause malfunction, fire and damage to unit.
2. Do not wire the power line with the high-voltage wire to prevent the signal line from the noise surge.
It will cause the malfunction.
3. Confirm the non-conductivity of wiring. It will cause the unit to be damaged by the excessive electric current flowing and voltage's being impressed, when there is insufficient insulation resistance.
4. Do not bend cable repeatedly, pull the cable, put the heavy object on the cable, and place the cable.

-Safety instructions for power supply

1. Even a single power supply and another power supply, the power supply are available, though 2 systems (for solenoid valve and for input and control) of wiring are necessary.
2. Choose UL recognized product for direct current power source to be mounted.
 - (1) Limited voltage current circuit complying with UL508

The power supply circuit made with secondary side coil of isolation transformer which satisfies the following condition

 - Max. voltage (No load applied) : 30Vrms (42.4V peak) or less, and
 - Max. current : 8A or less (Include when short), and restricted by the circuit protecting device (fuse) with rate in the table below

Voltage with no load (V peak)	Max. current rate
0 to 20 [V]	5.0
Exceeding 20 [V] up to 30 [V]	$\frac{100}{\text{Peak voltage}}$

- (2) Max. 30Vrms (42.4V peak) or less circuit (Class 2 circuit) which sources class 2 source unit complying with UL1310 or class 2 transformer complying with UL1585.

1. System structure

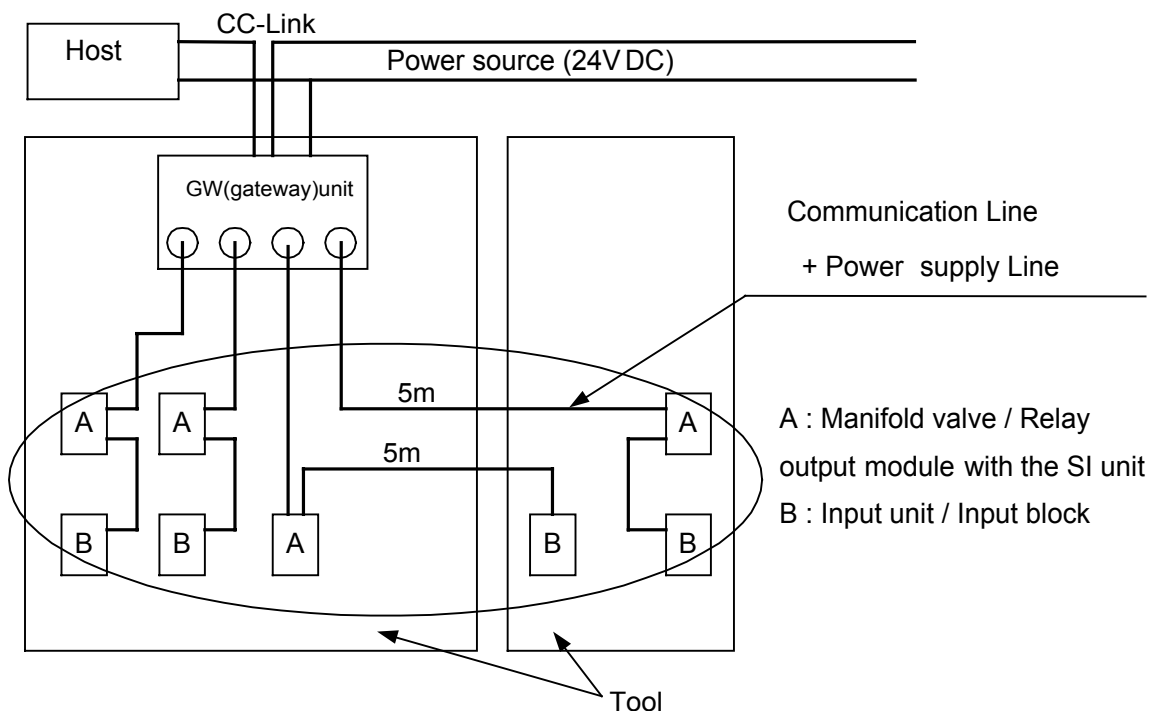

2. Specification

2-1. General specification

Item	Specification
Enclosure	IP65
Standard	UL, CSA, CE (Expect EX500 - GMJ1)
Withstand voltage	1500V AC 1min. (between PE - external terminal package)
Insulation resistance	2M Ω or more (500VDC meg. between PE - external terminal package)
Momentary power failure	1m sec. or less
Ambient temperature	+5°C to +45°C
Ambient humidity	35% to 85%RH (without condensation)
Preservation temperature	- 25°C to 70°C
Vibration proof	10Hz to 57Hz 0.35mm (constant amplitude) 57Hz to 150Hz 5G (constant speed) 2 hours each in directions of \pm X, Y and Z
Shock resistance	Peak value : 15G 3 times each in directions of \pm X, Y and Z
Applicable altitude	Less than 1000m above sea

2-2. Communication specification

Item	Specification									
Protocol	CC-Link									
Max. link points	Remote I/O : 2048 points									
Communication speed (BPS)	10M / 5M / 2.5M / 625K / 156K									
Communication type	Broad cast polling									
Synchronization	Frame synchronization									
Coding	NRZI									
Transmission path	RS485 bus									
Transmission format	Comply with HDLC									
Error control	CRC ($X^{16}+X^{12}+X^5+1$)									
RAS function	Automatic line reset Confirmation of data link condition Offline test (hardware , line test , parameter confirmatory test)									
Max. transmission Distance	Communication Speed(BPS)	156K	625K	2.5M	5M		10M			
	Total extended Distance (m)	1200	600	200	150	110	100	80	50	
	Station interval	#1	2m or more							
#2		30cm or more		60 cm or more	30 to 59 cm	1m or more	60 to 99 cm	30 to 59 cm		
Connection cable	#3 Twist pair cable with shield									

(Note)

#1 Between master local station and the adjoining stations.

#2 Between remote I/O station and remote device station.

#3 Twist pair cable with shield

Details of a twist pair cable recommended for CC-Link are as follows.
Performance of CC-Link cannot be granted if other than the cable below is used.

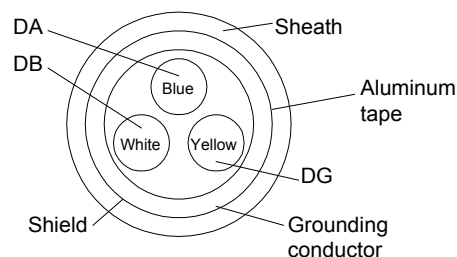

2-3. Gateway(GW) Unit specification (EX500 - GMJ1)

Item	Specification									
Rated voltage	24V DC									
Power supply voltage	For input And control	24V DC $\pm 10\%$								
	For solenoid valve	24V DC +10% / -5% (Warning of voltage drop given lower than approx. 20V)								
Current consumption	200mA or less (only GW unit)									
Input	64 points Max.									
Output	64 points Max.									
Input branch	4 branches (16 points / 1 branch)									
Output branch	4 branches (16 points / 1 branch)									
Branch connector	M12 connector (8 pin) socket Pin NO. 1. RD + 2. RD - 3. TD + 4. TD - 5. 24V DC (for solenoid valve) 6. 0V DC (for solenoid valve) 7. 24V DC (for power source) 8. 0V DC (for power source)									
Length of branch cable	Less than 5m (Less than 10m Max. Length)									

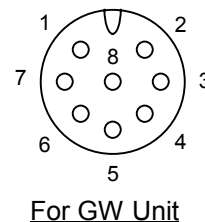

(Gateway(GW) Unit specification)

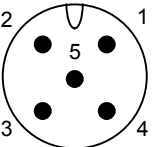
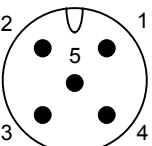
Item	Specification
Power supply connector	M12 connector (5 pin) plug <u>Pin NO.</u> 1. 0V (for solenoid valve) 2. 24V DC + 10% / - 5% 3A Max. (for solenoid valve) 3. 0V (for input and control) 4. 24V DC ± 10% 3A Max. (for input and control) 5. PE (Protective earth)  <u>For GW Unit</u>
Fieldbus connector (CC-Link)	M12 connector (5 pin) plug <u>Pin NO.</u> 1. DA 2. DB 3. DG 4. SLD 5. FG  <u>For GW Unit</u>

2 -4. Input Unit Manifold & Input Manifold (EEX500 - IB1 - □□)

The Input Manifold includes Input Unit (EX500 - IB1), End Block and DIN rail.

When placing order, enter some part NO. together. One for Input Manifold and others for Input Block.

The Input Unit Manifold can make various combinations of the block number of stations and specification of the sensor connector. But it isn't possible to mix the Input Block of the different sensor specification.

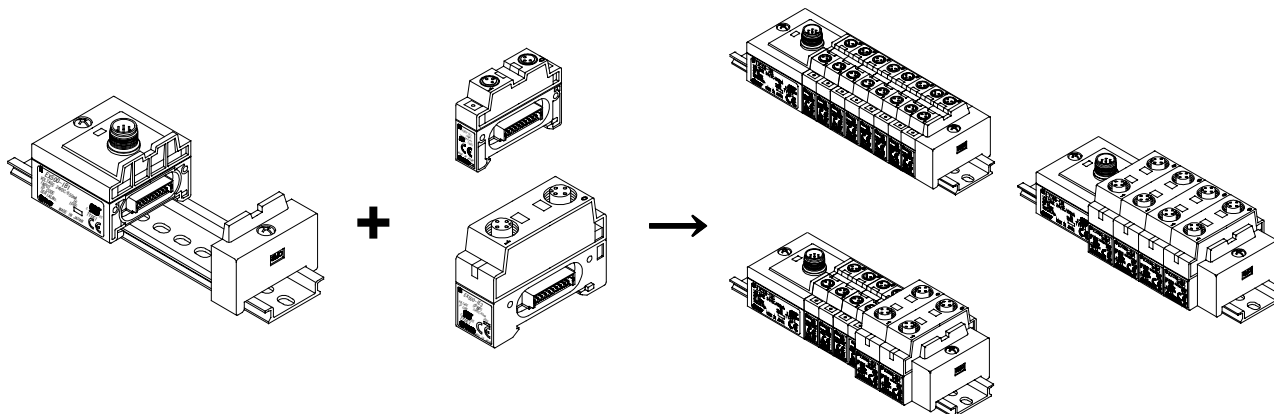
**Input Manifold****Input Block****Input Unit Manifold****2 -5. Input Unit specification (EX500 - IB1)**

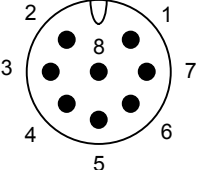
Item	Specification
Connecting block	Current source type Input block (PNP) or Current sink type input block (NPN)
Number of connecting block	8 blocks Max.
Power supply for block	24V DC
Current supply for block	0.65A Max.
Current consumption	100mA or less (in case of rated voltage)
Short circuit protection	1A Typ. for each unit (supply power cut) Cut power once and then supply it again for return.
Communication connector	M12 connector (8 pin) plug <u>Pin NO.</u> 1. RD + 2. RD - 3. N. C. 4. N. C. 5. N. C. 6. N. C. 7. 24V DC (for power source) 8. 0V DC (for power source)  <u>For Input Unit</u>

2-6. Input Block specification

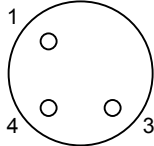
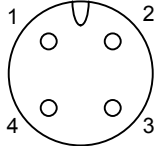
Item	Specification	
Models	EX500-IE1 (M8 connector) EX500-IE3 (M12 connector)	EX500-IE2 (M8 connector) EX500-IE4 (M12 connector)
Corresponding sensor	Current source type (PNP output)	Current sink type (NPN output)
Sensor connector	M8 connector (3 pin) socket Pin NO. 1. power supply (24V DC) 3. power supply (0V) 4. input  For input Block	M12 connector (4 pin) socket Pin NO. 1. power supply (24V DC) 2. (input) * Note 3. power supply (0V) 4. input  For Input Block
Input	2 points	
Rated voltage	24V DC	
Logical " 1 " input voltage	15V to 26.4V	0V to 8V
Logical " 0 " input voltage	0V to 5V	19V to 26.4V
Logical " 1 " input current	5mA Typ.	- 5mA Typ.
Logical " 0 " allowable voltage	1.5mA	- 1.5mA
Input delay	1m sec. or less	
Display	LED (green - colored) light up	
Insulation	Noting	
Sensor supply current	30mA Max. / sensor	

Note) Internal circuit of the M12 Input Block

Each No.2 pin of sensor connector of the M12 Input Block is connected to the other No.4 pin that is the sensor signal input pin of the connector.
Therefore, it is possible to input directly the two input signals of sensor gathered by one cable such as the assemble connector.
When connecting the sensor, confirm the specification of the output signal.
It will cause the malfunction.

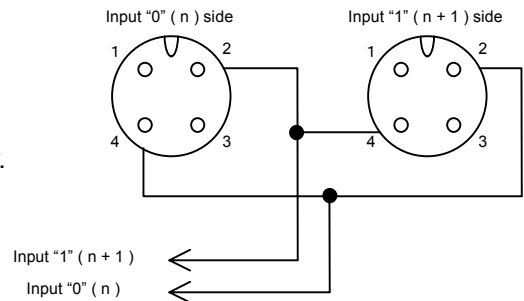

2 -7. SI Unit specification

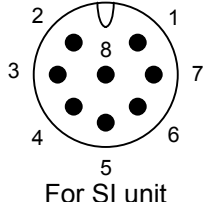
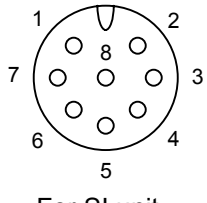
Item	Specification	
Models	EX500 - S001	EX500 - Q001 (NPN output) EX500 - Q101 (PNP output)
Applicable to Manifold Valve	SV series Manifold valve (SV1000 / 2000 / 3000 / 4000)	VQC series Manifold valve (VQC1000 / 2000)
Connecting block	Solenoid valve (Single , Double)	Solenoid valve (Single , Double)
	Relay output module (1 output , 2 output)	
Number of connecting block	Double solenoid valve Relay output module (2 Point) : 8 blocks Max.	Double solenoid valve : 8 blocks Max. Single solenoid valve : 16 blocks Max.
	Single solenoid valve Relay output module (1 Point) : 16 blocks Max.	
Power supply for block	24V DC	
Current supply for block	0.65A Max.	0.75A Max.
Current consumption	100mA or less (in case of rated voltage)	
Communication connector	C1 or " 0 "	<p>Connecting with GW unit. M12 connector (8 pin) plug <u>Pin NO.</u> 1. RD + 2. RD - 3. TD + 4. TD - 5. 24V DC (for solenoid valve) 6. 0V DC (for solenoid valve) 7. 24V DC (for power source) 8. 0V DC (for power source)</p>  <p style="text-align: center;"><u>For SI unit</u></p>
	C2 or " 1 "	<p>Connecting with input unit. M12 connector (8 pin) socket <u>Pin NO.</u> 1. RD + 2. RD - 3. N. C. 4. N. C. 5. N. C. 6. N. C. 7. 24V DC (for power source) 8. 0V DC (for power source)</p>  <p style="text-align: center;"><u>For SI unit</u></p>

Refer to the Catalogues or Technical Instruction Manual of SV and VQC series Manifold Valve for details.

3. Parts description

3-1. Parts description

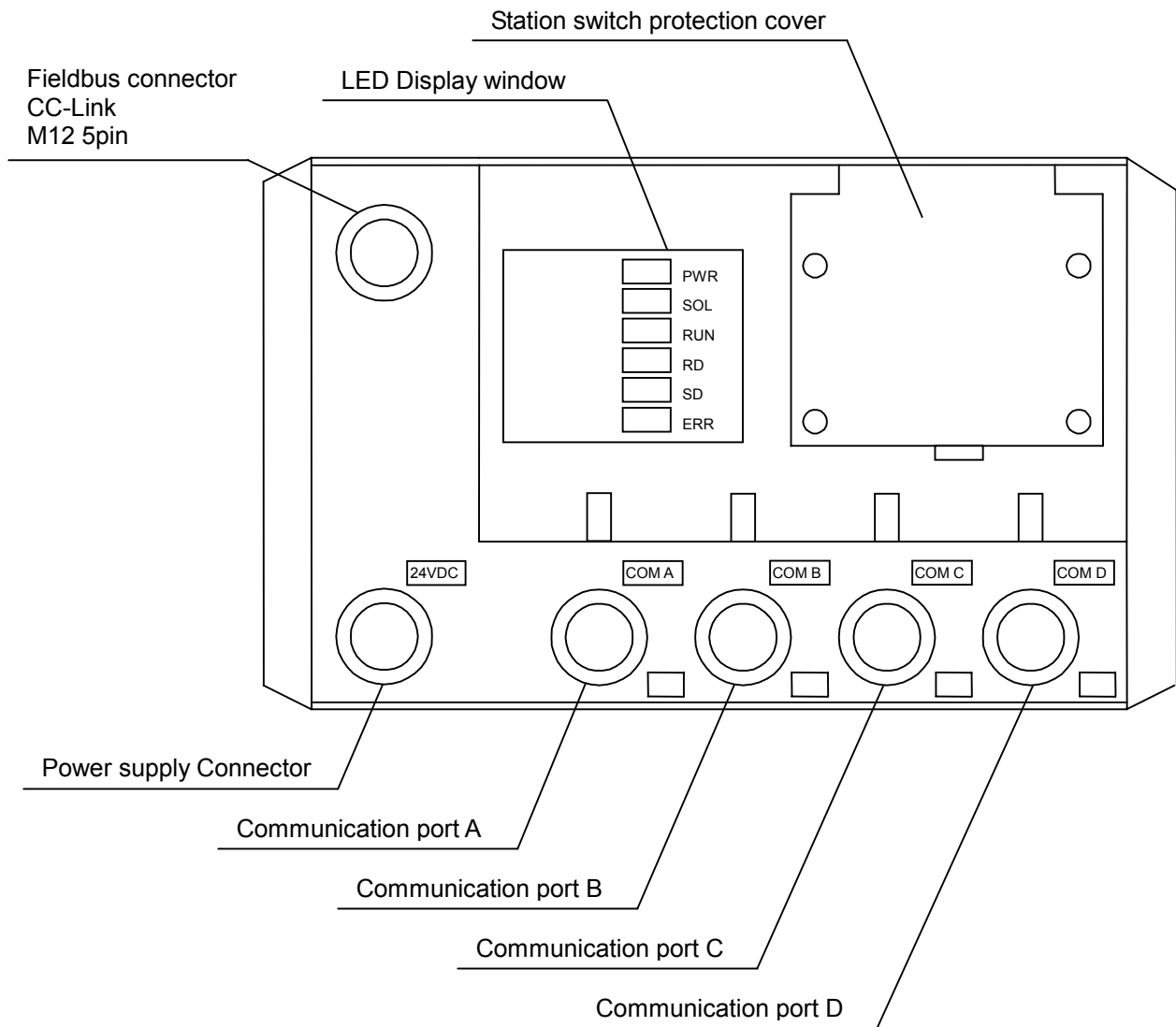

3 -2. LED display

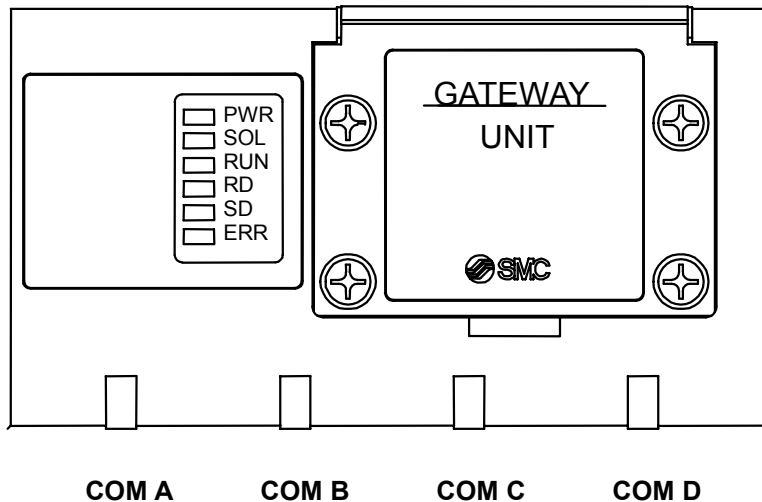

Display	Content
PWR	Source ON : Lights Source OFF : Light off
SOL	Solenoid valve source voltage is normal :Lights Voltage lowered to 20V or less :Light off
RUN	To see whether if SI unit communicates data with master station normally. Goes off due to overtime lighting when receiving normal data from master Station. (Lights up as receiving normal data.)
RD	Lights up as sending data.
SD	Lights up as receiving data.
ERR	Lights up when a transmission error (CRC error) occurs. Goes off due to overtime.(as well as RUN) Lights up if there is any error in station number setting or transmission speed setting. (Goes off when corrections are made and power is supplied again.) ERR blinks when setting of station number or transmission speed is changed. (RUN is lighting and the unit operates with a station number and transmission speed set at the first power supply.)
COM A	Communication port A is receiving data : Lights Communication port A has no data : Light off
COM B	Communication port B is receiving data : Lights Communication port B has no data : Light off
COM C	Communication port C is receiving data : Lights Communication port C has no data : Light off
COM D	Communication port D is receiving data : Lights Communication port D has no data : Light off

4. Switch setting

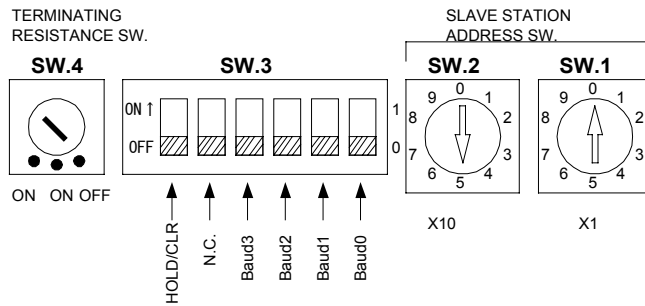

4-1. Slave Station Address SW.

Set station number with the range of 01 to 63.
 (00 station number setting is not allowed. Overlapped station number setting is not allowed.)
 EX500 - GMJ1 is 3 station used, max. station No. 63.

SW1. x1 is to set the units digit of a station number.
 SW2. x10 is to set the tens digit of a station number.

4-2. Transmission speed setting switch . (Baud0 - Baud3 SW.)

Set transmission speed within the range of 0 to 4.

Transmission Speed	Baud3 SW.	Baud2 SW.	Baud1 SW.	Baud0 SW.
156Kbps	0	0	0	0
625Kbps	0	0	0	1
2.5Mbps	0	0	1	0
5Mbps	0	0	1	1
10Mbps	0	1	0	0

4-3. HOLD/CLR SW. (HOLD/CLR SW3.)

In case of set 1, when it makes communication error is output clear.
 In case of set 0, when it makes communication error is output hold.

4-4. Terminating resistance SW. (SW4.)

Set termination resistance.

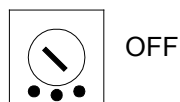

ON ON OFF

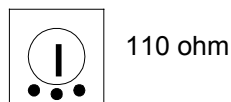

ON ON OFF

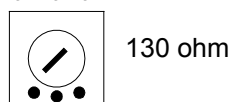

ON ON OFF

5. Addressing

		Input data														
COM-A Data	RX00	-														RX0F
	iA00	iA01	iA02	iA03	iA04	iA05	iA06	iA07	iA08	iA09	iA10	iA11	iA12	iA13	iA14	iA15
COM-B Data	RX10	-														RX1F
	iB00	iB01	iB02	iB03	iB04	iB05	iB06	iB07	iB08	iB09	iB10	iB11	iB12	iB13	iB14	iB15
COM-C Data	RX20	-														RX2F
	iC00	iC01	iC02	iC03	iC04	iC05	iC06	iC07	iC08	iC09	iC10	iC11	iC12	iC13	iC14	iC15
COM-D Data	RX30	-														RX3F
	iD00	iD01	iD02	iD03	iD04	iD05	iD06	iD07	iD08	iD09	iD10	iD11	iD12	iD13	iD14	iD15
Profile	RX40	-	RX42	-												RX4F
	-	-	#1	-	-	-	-	-	-	-	-	-	-	-	-	-
Profile	RX50	-									RX5A	RX5B	-			RX5F
	-	-	-	-	-	-	-	-	-	-	#2	#3	-	-	-	-
	RX60	-														RX6F
	not used															
	RX70	-														RX7F
	not used															

#1: Voltage lowered to 20VDC or less.

#2: Error flag.

#3: Remote ready.

		Output data														
COM-A Data	RY00	-														RY0F
	oA00	oA01	oA02	oA03	oA04	oA05	oA06	oA07	oA08	oA09	oA10	oA11	oA12	oA13	oA14	oA15
COM-B Data	RY10	-														RY1F
	oB00	oB01	oB02	oB03	oB04	oB05	oB06	oB07	oB08	oB09	oB10	oB11	oB12	oB13	oB14	oB15
COM-C Data	RY20	-														RY2F
	oC00	oC01	oC02	oC03	oC04	oC05	oC06	oC07	oC08	oC09	oC10	oC11	oC12	oC13	oC14	oC15
COM-D Data	RY30	-														RY3F
	oD00	oD01	oD02	oD03	oD04	oD05	oD06	oD07	oD08	oD09	oD10	oD11	oD12	oD13	oD14	oD15
	RY40	-														RY4F
	not used															
	RY50	-														RY5F
	not used															
	RY60	-														RY6F
	not used															
	RY70	-														RY7F
	not used															

6. Operation setting

6-1. Correspondence of input number and Input Block (Input Unit)

The input block can be connected up to eight (8) block (16 points).
 The input number (16 points) is set from input unit side.

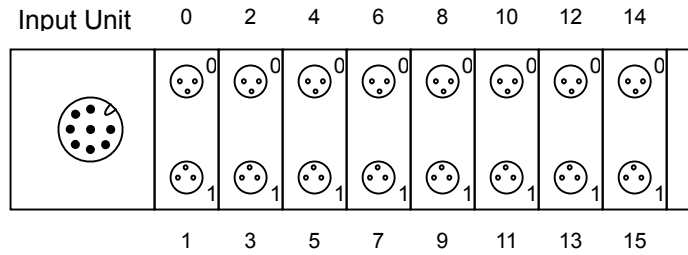

6-2. Correspondence of output number and Manifold Valve (SI Unit)

The output number to the manifold valve of the SI unit becomes like the following figure.
 The SI unit has output of 16 points.
 In case of the relay output block, it becomes like the single solenoid valve.

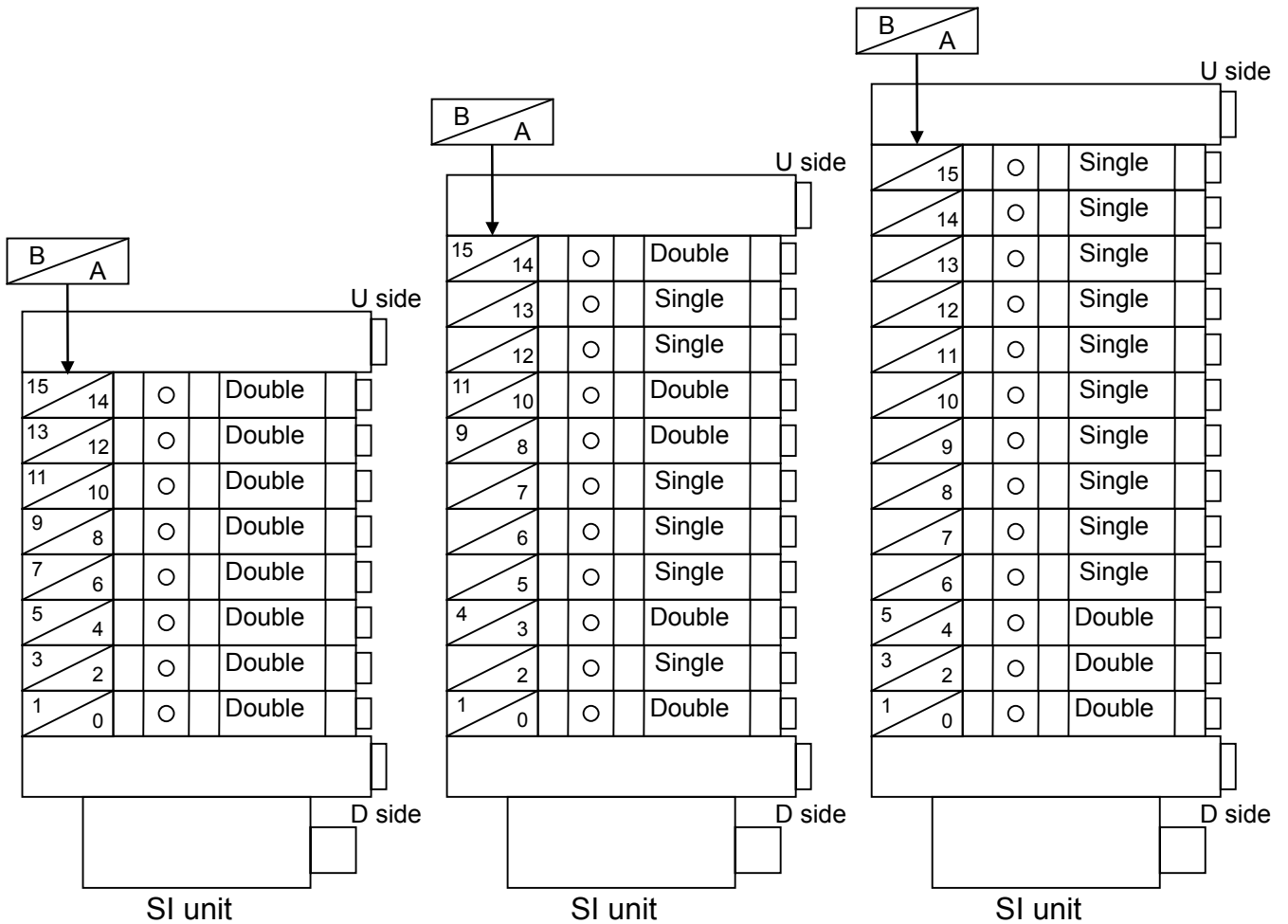

Example : In case of 8 stations of the double solenoid valve

Example : In case of the single solenoid valve and the double solenoid valve intermingling

7. Wiring

7 -1. Source wiring

Source wiring is connected with M12 connector (5 pin) (Refer clause 3 -1.).

Wire to assigned pin. (Refer clause 2 -3.)

Source lines inside of the GW Unit have independent power source for the solenoid valve and for the input and control.

Supply power (24V DC) to both power sources.

The cable with connector for the power source is recommended for wiring.

(P/N : EX500 - AP*** - *)

7 -2. Communication wiring

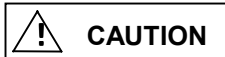

Wire the communication cable with the power supply turn OFF.

7 -2 -1. CC - Link communication wiring

CC - Link communication is connected with M12 connector (5 pin). (Refer clause 3 -1.)

Wiring to assigned pin. (Refer clause 2 -3.)

7 -2 -2. Wiring to the SI Unit and the Input Unit

The wiring to each unit is respectively connected with M12 connector (8 pin). (Refer clause 3 -1.)

Wire to assigned pin. (Refer clause 2 -3.)

The cable with the M12 connector is recommended for wiring.

(P/N : EX500 - AC*** - S**P*)