

# Series 11-22-MSQ

Rack & Pinion Type Rotary Table  
Size: 1, 2, 3, 7, 10, 20, 30, 50

## How to Order

### Size: 1, 2, 3, 7

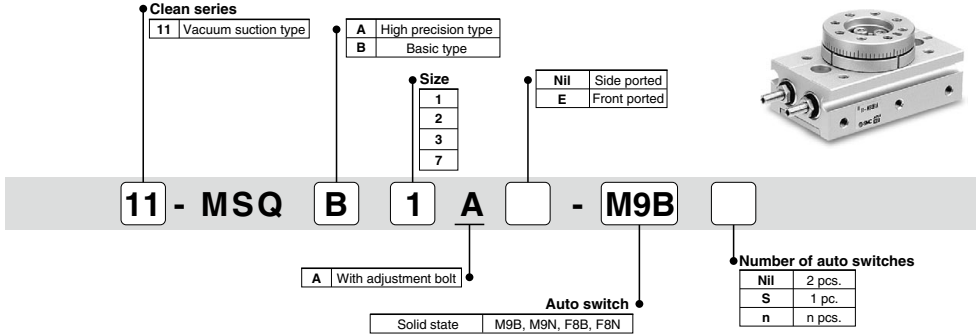

### Size: 10, 20, 30, 50

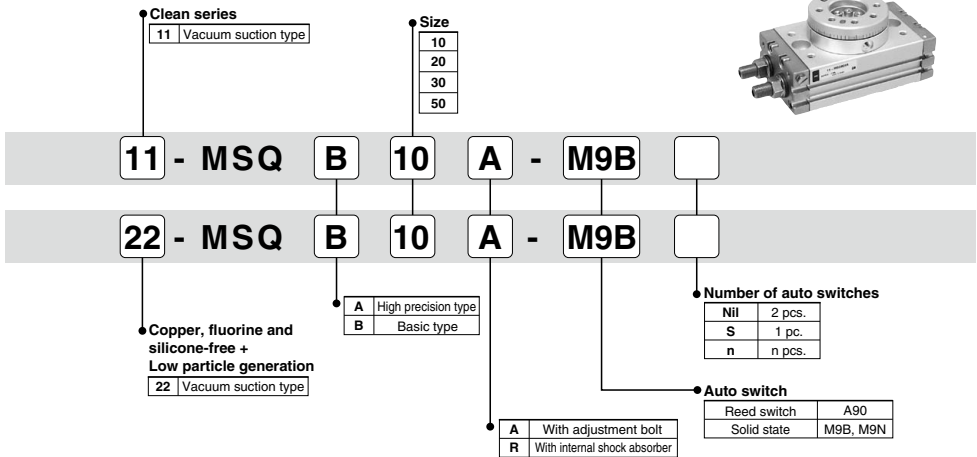

## Auto Switch Specifications

Type	Auto switch model	Load voltage	Load current range	Indicator light	Applicable load
Reed auto switch	<b>D-A90</b>	24 VAC or less, 48 VAC or less, 100 VAC or less 24 VDC or less, 48 VDC or less, 100 VDC or less	50 mA, 40 mA, 20 mA	No	IC circuit, Relay, PLC
Solid state auto switch	2-wire <b>D-M9B, D-F8B</b>	24 VDC (10 to 28 VDC)	2.5 to 40 mA	Yes	24 VDC relay, PLC
	3-wire <b>D-M9N, D-F8N</b>	24 VDC (4.5 to 28 VDC)	40 mA or less	Yes	24 VDC relay, PLC

Refer to page 920 for the applicable auto switch list.

## Specifications

Size	1	2	3	7	10	20	30	50	
Fluid	Air (Non-lube)								
Maximum operating pressure	With adjustment bolt			0.7 MPa			1 MPa		
	With internal shock absorber			Not available			0.6 MPa		
Minimum operating pressure	Basic type								
	0.1 MPa								
Ambient and fluid temperature	High precision type			0.1 MPa			0.2 MPa		
	0.1 MPa			0.2 MPa			0.1 MPa		
Cushion	0 to 60°C (No freezing)								
	With adjustment bolt			Not available					Rubber bumper
Allowable kinetic energy (mJ)	With internal shock absorber			Not available			Shock absorber		
	1			1.5			2		
With internal shock absorber			6			7			
With internal shock absorber			39			116			
With internal shock absorber			116			294			
Angle adjustment range								0 to 190°	
Maximum rotating angle								190°	
Rotation time	With adjustment bolt			0.2 to 0.7 s/90°			0.2 to 1.0 s/90°		
	With internal shock absorber			Not available			0.2 to 0.7 s/90°		
Port size			M3 x 0.5			M5 x 0.8		Rc 1/8, M5 x 0.8	
Grease								11-: Fluorine grease 22-: Lithium soap based grease	
Cleanliness class (ISO class)								11-: Class 3 22-: Class 3	

## Suction Flow Rate of Vacuum Suction Type (Reference values)

Size	Suction flow rate L/min (ANR)
1/2/3/7	1
10/20/30/50	

## Rotation Range Example

- The rotary table turns in the clockwise direction when the A port is pressurized, and in the counterclockwise direction when the B port is pressurized.
- By adjusting the adjustment bolt, the rotation end can be set within the ranges shown in the drawing for the desired rotation angle.
- The rotation angle can also be set on a type with internal shock absorber.

### Size: 1 to 7

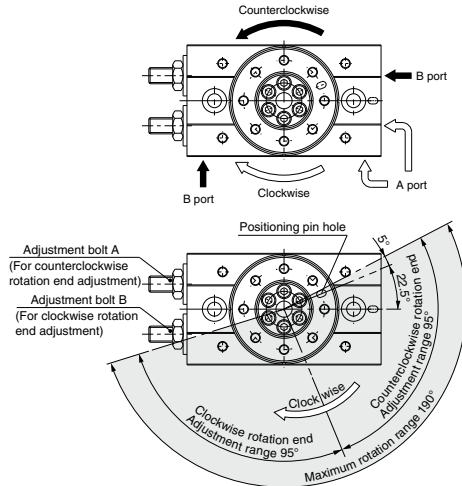

Note) · The drawing shows the rotation range of the positioning pin hole.  
· The pin hole position in the drawing shows the counterclockwise rotation end when the adjustment bolts A and B are tightened equally and the rotation is adjusted 180°.

#### With adjustment bolt, internal shock absorber

Size	Adjustment angle per rotation of angle adjustment bolt
1	8.2°
2	10.0°
3	10.9°
7	10.2°

### Size: 10 to 50

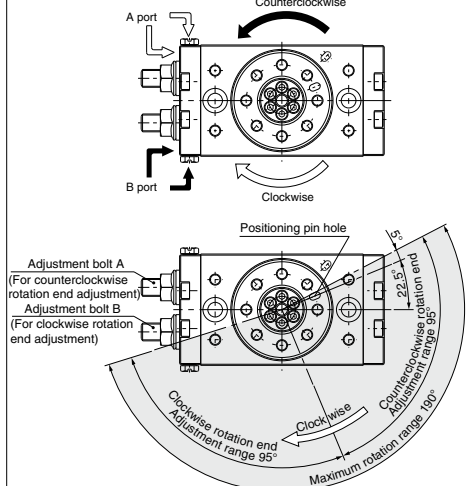

Note) · The drawing shows the rotation range of the positioning pin hole.  
· The pin hole position in the drawing shows the counterclockwise rotation end when the adjustment bolts A and B are tightened equally and the rotation is adjusted 180°.

#### With adjustment bolt, internal shock absorber

Size	Adjustment angle per rotation of angle adjustment bolt
10	10.2°
20	7.2°
30	6.5°
50	8.2°

**Auto Switch Proper Mounting Position (Detection at Rotation End)**

Size: 1 to 7

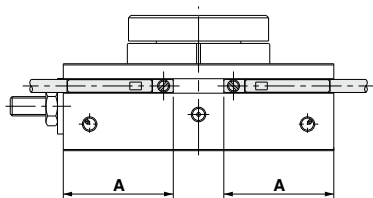

D-F9, M9

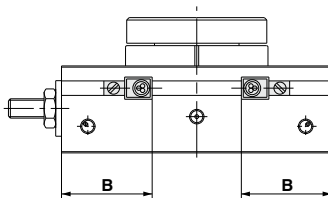

D-F8

Size	Rotating angle	Solid state auto switch					
		D-M9□			D-F8□		
		A	Operating angle $\theta$ m	Hysteresis angle	B	Operating angle $\theta$ m	Hysteresis angle
1	190°	20.9	49°	10°	16.9	20°	10°
2	190°	22.8	50°	10°	18.8	20°	10°
3	190°	24.4	47°	10°	20.4	15°	10°
7	190°	28.7	31°	10°	24.7	15°	10°

Operating angle  $\theta$  m: Converts the operating range (Lm) of the auto switch into the rotation angle  
 Angle of hysteresis: The hysteresis of the auto switch is converted to degrees.

Size: 10 to 50

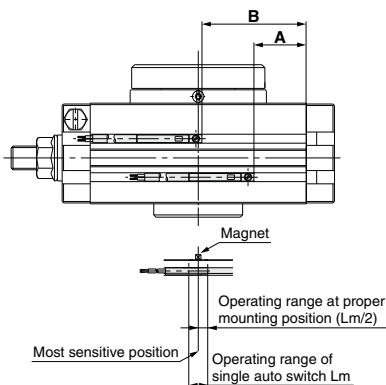

Size	Rotating angle	Reed auto switch				Solid state auto switch			
		D-A9□, D-A9□V				D-M9□			
		A	B	Operating angle $\theta$ m	Hysteresis angle	A	B	Operating angle $\theta$ m	Hysteresis angle
10	190°	27	45	90°	10°	31	49	42°	10°
20	190°	35	62	80°	10°	39	66	35°	10°
30	190°	39	68	65°	10°	43	72	30°	10°
50	190°	49	83	50°	10°	53	87	24°	10°

Operating angle  $\theta$  m: Converts the operating range (Lm) of the auto switch into the rotation angle  
 Angle of hysteresis: The hysteresis of the auto switch is converted to degrees.

**Dimensions: Size 1, 2, 3, 7**

Basic type: 11-MSQB□A

High precision type: MSQA□A

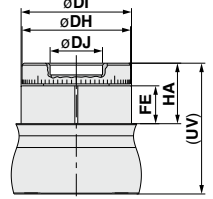
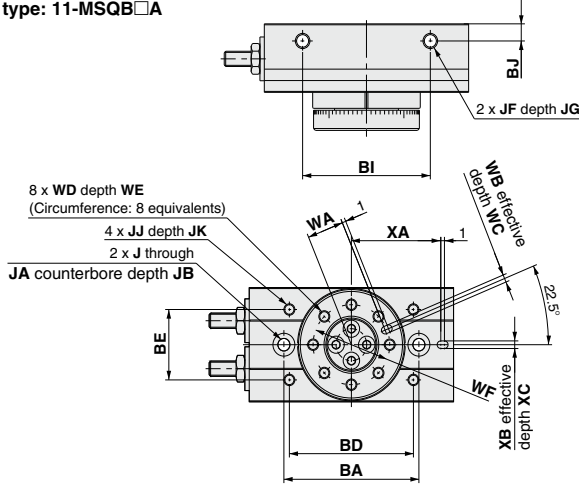

Size	DH	DI	DJ	FE	HA	UV
1	27h8	27.5h8	14H8	8.2	13.5	29.5
2	29h8	29.5h8	14H8	9.7	15.5	33.5
3	33h8	34h8	17H8	9.7	15.5	36
7	39h8	40h8	20H8	9.5	16.5	39.5

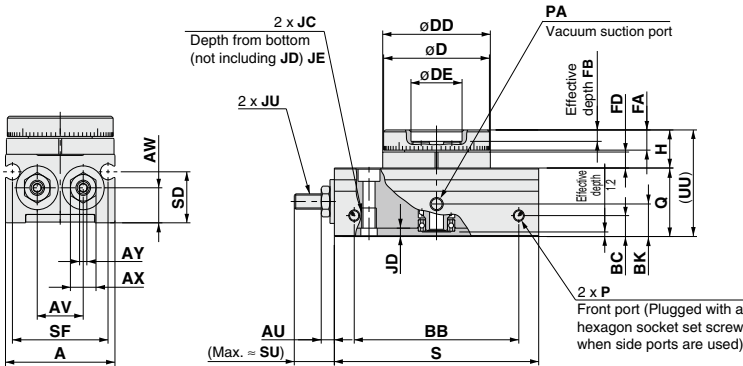

Size	A	AU	AV	AW	AX	AY	BA	BB
1	28	2.8	11	8.2	5.5	1.5	35	39.6
2	30	3.6	12.6	9.2	7	2	37	45.1
3	34.5	4.4	15.5	10.5	8	2.5	43	46.7
7	41	4.8	18.4	12.2	10	3	50	59.2

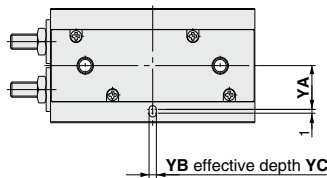

Size	BC	BD	BE	BG	BH	BI	BJ	BK	D	DD	DE	FA	FB	FD	H	J	JA	JB	JC	JD	JE	JF	JG
1	4.5	32	17	11	8.2	30	4.5	5.3	27h9	27.5h9	14H9	4.8	2	3.7	9	3.3	6	3.5	M4 x 0.7	2.2	5.3	M4 x 0.7	4
2	5.5	34	18.5	12.6	9.2	35	4.5	7.5	29h9	29.5h9	14H9	5.3	2.5	4.2	10	3.3	6	3.5	M4 x 0.7	2.2	5.3	M4 x 0.7	4
3	5.5	38	23	15.5	10.5	40	4.5	9.5	33h9	34 h9	17H9	5.3	2.5	4.2	10	4.2	7.5	4.5	M5 x 0.8	2.5	6	M4 x 0.7	4
7	5.5	45	30	18.4	12.2	50	5	7	39h9	40 h9	20H9	6.5	2.5	4.5	11.5	4.2	7.5	4.5	M5 x 0.8	2.5	6	M5 x 0.8	5

Size	JJ	JK	JU	P	PA	Q	S	SD	SF	SU	UU	WA	WB	WC	WD	WE	WF	XA	XB	XC	YA	YB	YC
1	M3 x 0.5	3.5	M3 x 0.5	M3 x 0.5	M3 x 0.5	16	50.5	10.8	24.4	9.4	25	9.5	2H9	2	M3 x 0.5	4.8	20	22.5	2H9	2	11	2H9	2
2	M3 x 0.5	3.5	M4 x 0.7	M3 x 0.5	M3 x 0.5	18	56	13.4	26.2	11.3	28	10	2H9	2	M3 x 0.5	5.3	21	24.5	2H9	2	11.5	2H9	2
3	M3 x 0.5	3.5	M5 x 0.8	M3 x 0.5	M3 x 0.5	20.5	60	15.2	31	11.8	30.5	12	2H9	2	M3 x 0.5	5.3	25	27	2H9	2	13.5	2H9	2
7	M4 x 0.7	4.5	M6 x 1	M5 x 0.8	M5 x 0.8	23	73.5	15.4	37.4	14.9	34.5	14	3H9	3	M4 x 0.7	6.5	29	32.5	3H9	3	15.5	3H9	3

- Directional Control Valves
- Air Cylinders
- Rotary Actuators
- Air Grippers
- Air Preparation Equipment
- Modular F. R.
- Pressure Control Equipment
- Fittings & Tubing
- Flow Control Equipment
- Pressure Switches/ Pressure Sensors

Dimensions: Size 10, 20, 30, 50

Basic type: <sup>11-</sup>22-MSQB□A

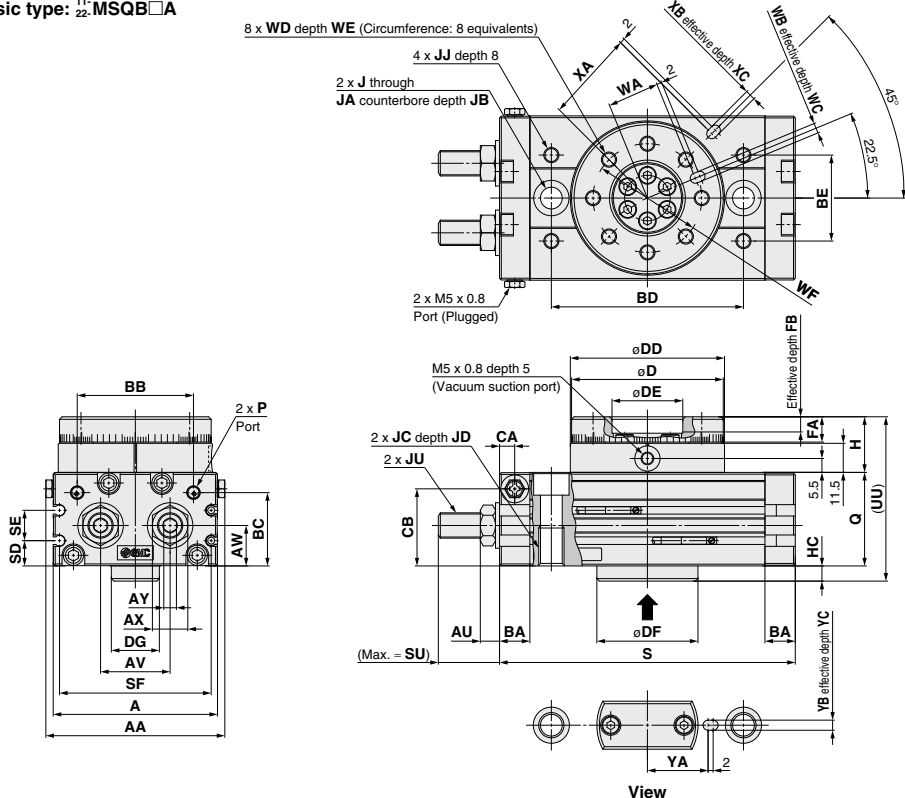

**With internal shock absorber**  
<sup>11-</sup>22-MSQA□  
<sup>11-</sup>22-MSQB□  
  
 (Max. = FU)  
 (mm)

Size	FU
10	31.5
20	34.7
30	34.7
50	51.7

**High precision type**  
<sup>11-</sup>22-MSQA□A  
  
 (mm)

Size	DA	DB	DC	DF	HA	HB	HC	HD	HE
10	46h8	45h8	20H8	35h8	15.5	24	5	63	9.5
20	61h8	60h8	28H8	40h8	19.5	30	6	73	13.5
30	67h8	65h8	32H8	48h8	19.5	30	6	76	13.5
50	77h8	75h8	35H8	54h8	21.5	34	7	87	15.5

Size	AA	A	AU	AV	AW	AX	AY	BA	BB	BC	BD	BE	CA	CB	D	DD	DE	DF	DG	FA	FB	H	HC	J	JA	JB
10	55.4	50	6.6	20	15.5	12	4	9.5	34.5	27.8	60	27	4.5	28.5	45h9	46h9	20H9	35h9	17	8	4	20	5	6.8	11	6.5
20	70.8	65	7.6	27.5	16	14	5	12	46	29	76	34	6	30.5	60h9	61h9	28H9	40h9	19	10	6	22	6	8.6	14	8.5
30	75.4	70	7.6	29	18.5	14	5	12	50	32	84	37	6.5	33.5	65h9	67h9	32H9	48h9	24	10	4.5	22	6	8.6	14	8.5
50	85.4	80	10	38	22	19	6	15.5	63	37.5	100	50	10	37.5	75h9	77h9	35H9	54h9	28	12	5	24	7	10.5	18	10.5

Size	JC	JD	JJ	JU	P	Q	S	SD	SE	SF	SU	UU	WA	WB	WC	WD	WE	WF	XA	XB	XC	YA	YB	YC
10	M8 x 1.25	12	M5 x 0.8	M8 x 1	M5 x 0.8	34	92	9	13	45	17.7	59	15	3H9	3.5	M5 x 0.8	8	32	27	3H9	3.5	19	3H9	3.5
20	M10 x 1.5	15	M6 x 1	M10 x 1	M5 x 0.8	37	117	10	12	60	25	65	20.5	4H9	4.5	M6 x 1	10	43	36	4H9	4.5	24	4H9	4.5
30	M10 x 1.5	15	M6 x 1	M10 x 1	Rct/8	40	127	11.5	14	65	25	68	23	4H9	4.5	M6 x 1	10	48	39	4H9	4.5	28	4H9	4.5
50	M12 x 1.75	18	M8 x 1.25	M14 x 1.5	Rct/8	46	152	14.5	15	75	31.4	77	26.5	5H9	5.5	M8 x 1.25	12	55	45	5H9	5.5	33	5H9	5.5