



Air Cylinder

Series *NCA1* NFPA Interchangeable



- Medium Duty 1.5" to 4" Bore
- 12 Different NFPA Mounting Options
- Non-Rotating Option
- Tandem Cylinder Option
- Auto Switch Capable

Air Cylinder NFPA Interchangeable

Series NCA1

Improved cushion capacity

“Floating” cushion seal design eliminates piston rod “bouncing” due to cracking pressure at beginning of stroke.

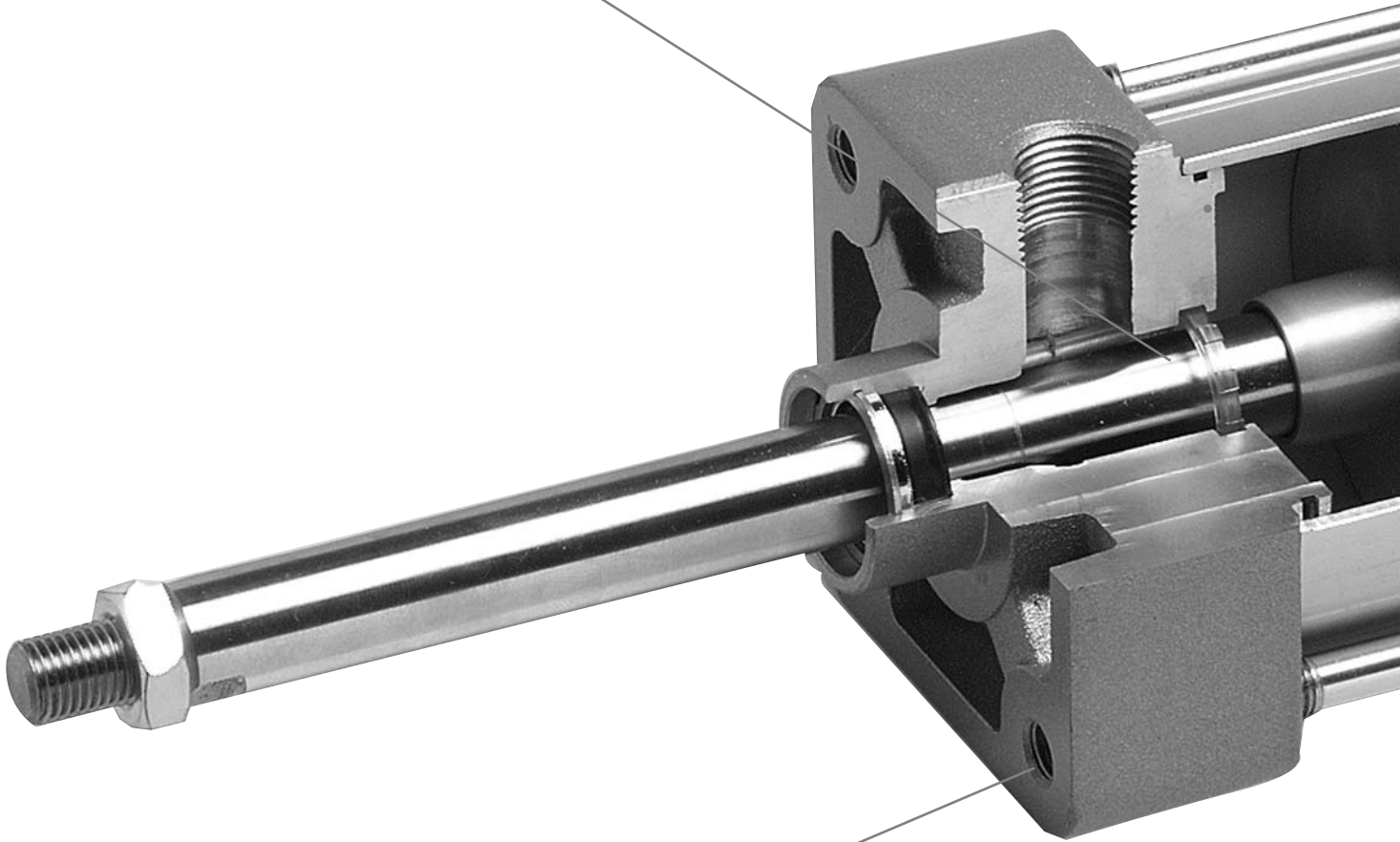

Compact and lightweight design

The square covers are made of an aluminum die casting and provide a lower cost, lighter weight product.

ø1.5", ø2", ø2.5", ø3.25", ø4"

Increased kinetic energy absorption

The absorption of kinetic energy had been increase by nearly 30% through increase cushion volume and the use of a new cushion seal.

Full port design

Allows for improved piston breakaway.

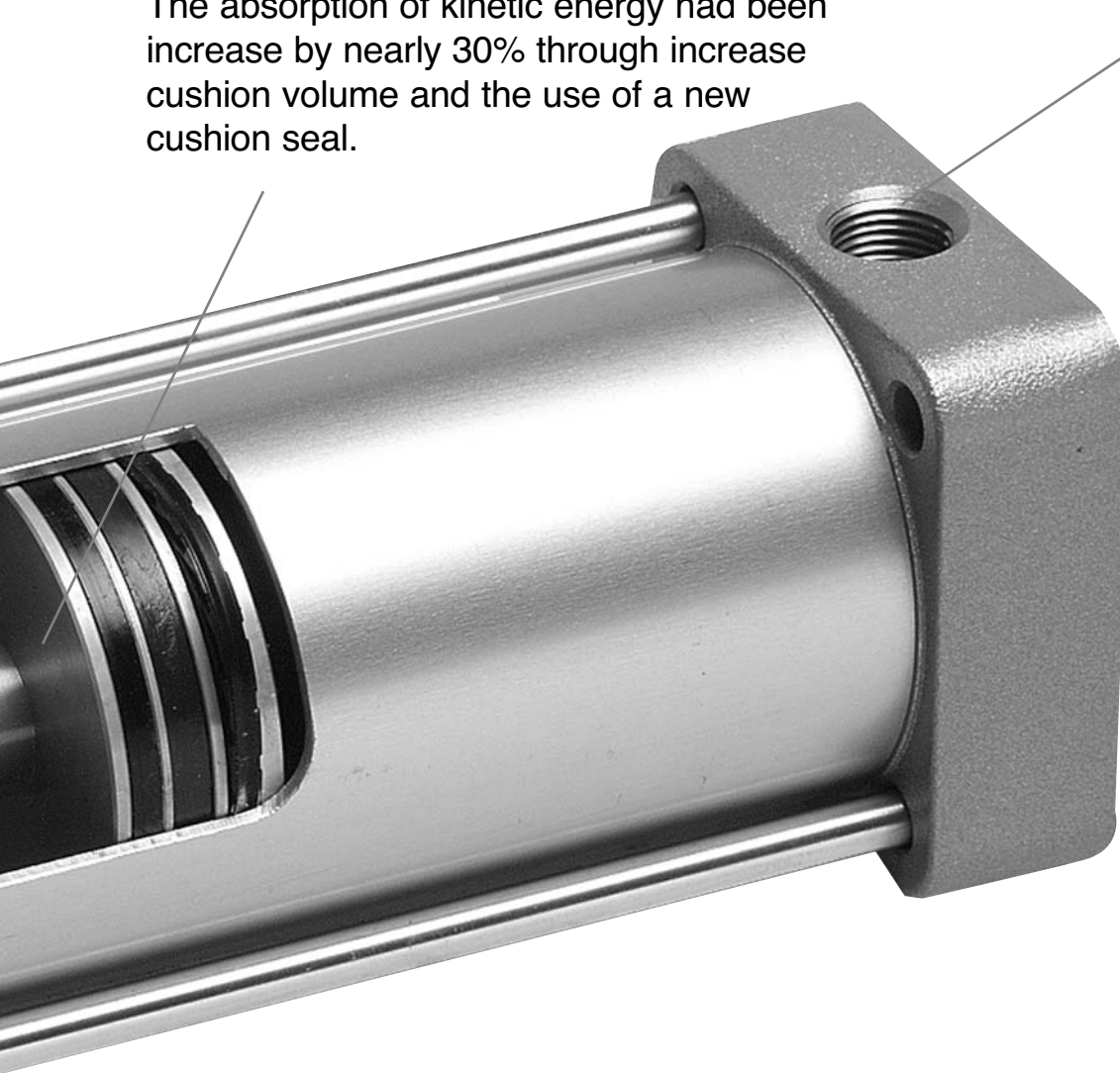

Full range of NFPA interchangeable mounting configurations

Mounting Dimensions are in accordance with ANSI (NFPA) T3.6.7 R2-1996, Fluid Power Systems and Products - Square Head Industrial Cylinders - Mounting Dimensions.

Table of Contents

How to Order	5
Specifications	6
Construction / Part List / Seal Kit	7
Basic Mounting	8
Foot Mounting	8
Front Flange Mounting	9
Rear Flange Mounting	9
Side Tapped Mounting	10
Double Detachable Rear Clevis Mounting	10
Center Trunnion Mounting	11
Single Detachable Rear Clevis Mounting	11
Double Rear Clevis Mounting	12
Side Lug Mounting	12
Rod Trunnion Mounting	13
Head Trunnion Mounting.....	13
Double Rod	14 to 16
Non-Rotating Rod and Double Rod Non-Rotating	17 to 24
Stainless Steel Rod (XC6) Low Speed (XB9)	25
High Temperature (XB6) / Low Temperature (XB7)	26
Special Trunnion Location (X46US)	27 & 28
Oversized Rod with Special Trunnion Location (XB5 - X46US)	29
Stainless Steel Tie Rods / Tie Rod Nuts (X130US)	30
Rod Boot	31
Oversized Rod / Standard Rod and Non-Rotating (XB5 / X119US)	32 to 36
Adjustable Stroke – Extended (XC8)	37
Adjustable Stroke – Return (XC9)	38
Dual Operation – Double Rod (XC10)	39
Dual Operation – Single Rod (XC11)	40
Special Rod End Modifications	41
Accessories	42
Auto Switch Options	43 to 51
Precautions	52 to 58

How To Order

NC **D** A1 **B** 150 - 04 00 - A51 - XB5

Auto Switch

Nil	Standard
D	With Auto Switch (Magnetic Piston)

Model

Nil	Standard Cylinder
K	Non-Rotating Cylinder
W	Double Rod
M	Male Rod Stud

Mounting

B	MX0	Basic
L	MS1	Foot
F	MF1	Front Flange
G	MF2	Rear Flange
R	MS4	Side Tapped
D	MP2	Double Detachable Rear Clevis
T	MT4	Center Trunnion
C	MP4	Single Detachable Rear Clevis
X	MP1	Double Rear Clevis
S	MS2	Side Lug
U	MT1	Rod Trunnion
J	MT2	Head Trunnion

Bore Size

150	1.5"
200	2"
250	2.5"
325	3.25"
400	4"

For larger bore size up to 32" bore. Please consult CAT: N304-EX.

Standard Stroke

Inches

Stroke

Hundredths of an Inch

Options

XB5	Oversized Rod
XB6	High Temperature
XB7	Low Temperature
XB9	Low Speed
XC6	Stainless Steel Piston Rod
XC8	Adjustable Stroke Extended
XC9	Adjustable Stroke Return
XC10	Dual Operation/Double Rod
XC11	Dual Operation/Single Rod
XC22	Viton Seals
XC35	With Coil Scraper
X46US	Special Trunnion Location
X119US	Non-Rotating Oversize Rod
X130US	Stainless Steel Piston Rod, Tie Rod, Tie Rod Nut, Cushion Valve Needle

For special rod end modifications please see page 41.

No. of Switches

Nil	2 Pieces
S	1 Piece
n	"n" Pieces

Rod Boot

Nil	Without Boot
J	Nylon Boot
K	Neoprene Boot

Air Cushion

Nil	Both Ends
N	None
H	Head End
R	Rod End

Mounting Bracket Part Numbers

Mounting Bracket / Bore	Part Number				
	150 (1.5")	200 (2")	250 (2.5")	325 (3.25")	400 (4")
Foot	NCA1-L150	NCA1-L200	NCA1-L250	NCA1-L325	NCA1-L400
Flange	NCA1-F150	NCA1-F200	NCA1-F250	NCA1-F325	NCA1-F400
Double Clevis (MP2)	NCA1-D150	NCA1-D200	NCA1-D250	NCA1-D325	NCA1-D400
Single Clevis	NCA1-C150	NCA1-C200	NCA1C250	NCA1-C325	NCA1-C400
Side Lug	NCA1-S150	NCA1-S200	NCA1-S250	NCA1-S325	NCA1-S400
Double Clevis (MP1)	NCA1-X150	NCA1-X200	NCA1-X250	NCA1-X325	NCA1-X400

* These Kits are for Standard Single Rod/Double Acting Cylinders without Options. For Option Kits, please contact your local SMC sales office. One Kit required per cylinder.



The SMC NCA1 expanded series NFPA Industrial Interchangeable Pneumatic Cylinders are now available in bore sizes ranging from 5" to 8" Medium Duty, and 1.5" to 14" Heavy Duty.

The NCA1 Expanded Series Cylinders offer:

- Replaceable Rod Gland
- A full range of NFPA interchangeable mounting configurations
- Available in three construction types: Aluminum, Steel, and Stainless Steel
- Composite fiber tube optional
- Fully adjustable cushion

For further information, please consult your local SMC sales office.

Specifications



Type	Standard	Double Rod	Non-Rotating Rod
Fluid	Air	Air	Air
Lubrication	Non-lube	Non-lube	Non-lube
Max. Operating Pressure	250psi (1.75MPa)	250 psi (1.75MPa)	250 psi* (1.75MPa)
Min. Operating Pressure	8 psi (0.06MPa)	8 psi (0.06MPa)	15 psi (0.1MPa)
Ambient and Fluid Temp.	40 to 140°F (5 to 60°C)	40 to 140°F (5 to 60°C)	40 to 140°F (5 to 60°C)
Piston Speed	2 to 20in/s (50 to 500mm/s)	2 to 20in/s (50 to 500mm/s)	2 to 20in/s (50 to 500mm/s)
Mounting	Basic, Foot Front and Rear Flange Side Tapped, Clevis Center Trunnion, Side Lug Rod and Head Trunnion	Basic, Foot Flange Side Tapped Center and Rod Trunnion	Basic, Foot Front and Rear Flange Side Tapped, Clevis Center Trunnion, Side Lug Rod and Head Trunnion
Non-Rotating Accuracy	n/a	n/a	±0.50°

* Rod and head trunnion maximum operating pressure for 325 and 400 bore is up to 150 psi

Standard Strokes

(in)

Bore Size	Standard Stroke	Maximum Stroke
1.5"	1, 2, 3, 4, 5, 6, 8, 10, 12, 14, 16, 18, 20, 24	
2", 2.5"	1, 2, 3, 4, 5, 6, 8, 10, 12, 14, 16, 18, 20, 24	Consult SMC
3.25", 4"	1, 2, 3, 4, 5, 6, 8, 10, 12, 14, 16, 18, 20, 24, 28, 30	

Base Material / Surface Treatment

Description	Material	Note
Cover	Aluminum alloy	Silver paint
Tube	Aluminum alloy	Hard alumite
Seals	Nitrile rubber	PLD, PLP
Piston Rod	Carbon steel	Hard chromate
Piston	Aluminum alloy	Hard alumite

Weight / Aluminum Tube

(lbs)

Bore Inch		150 (1.5")	200 (2")	250 (2.5")	325 (3.25")	400 (4")
Basic Weight	Basic type	1.58	2.35	3.19	6.03	7.79
	Foot mounting	1.95	2.86	3.80	7.45	10.1
	Flange mounting	2.30	3.22	4.34	8.85	11.66
	Clevis mounting	2.27	3.23	4.28	8.95	11.41
Additional weight per 2" stroke	Trunnion mounting	2.79	3.81	5.50	10.05	13.50
	For all mountings	0.38	0.48	0.51	0.97	1.06

Cylinder Bores and Forces: Push Stroke

Bore (in)	Piston Area (in ²)	Forces (lbs); Push Stroke Operating Medium Pressure (psi)					
		50	60	80	100	200	250
1.5	1.767	88	106	141	177	353	442
2	3.142	157	188	251	314	628	785
2.5	4.909	245	295	393	491	982	1227
3.25	8.296	415	498	664	830	1659	2074
4	12.566	628	754	1005	1257	2513	3142

To calculate thrust forces not shown in the table, multiply operating pressure by piston area.

How to use this table

- Locate column with desired operating pressure.
- Move down that column and locate the thrust value which is equal (or the next larger to the force to be delivered by the cylinder).
- On that same line, locate in the first (left) column the bore size recommended for your application.

Note: These are *guide lines only*, which must be substantiated using additional data specific to your application.

Cylinder Bores and Forces: Pull Stroke

Piston Rod Diameter (in)	Piston Rod Area (in ²)	Forces (lbs); Pull Stroke (Deduct the listed thrusts corresponding to the rod size from push stroke pressure) Operating Medium Pressure (psi)					
		50	60	80	100	200	250
0.625	0.307	15	18	25	31	61	77
1	0.785	39	47	63	79	157	196
1.375	1.485	74	89	119	148	297	371

To calculate pull forces not shown in the table, use the following formula:

$$\text{Pull Force} = (\text{Piston Area} - \text{Rod Area}) \times \text{Working Pressure}$$

How to use this table

- To find the force on the pull stroke, locate the required piston rod diameter in the left most column.
- Moving to the right, locate the required working pressure.
- Deduct the value shown at the intersection from the push stroke force value determined from the Push Stroke table. The resultant is the available pull stroke table.

Construction / Parts List

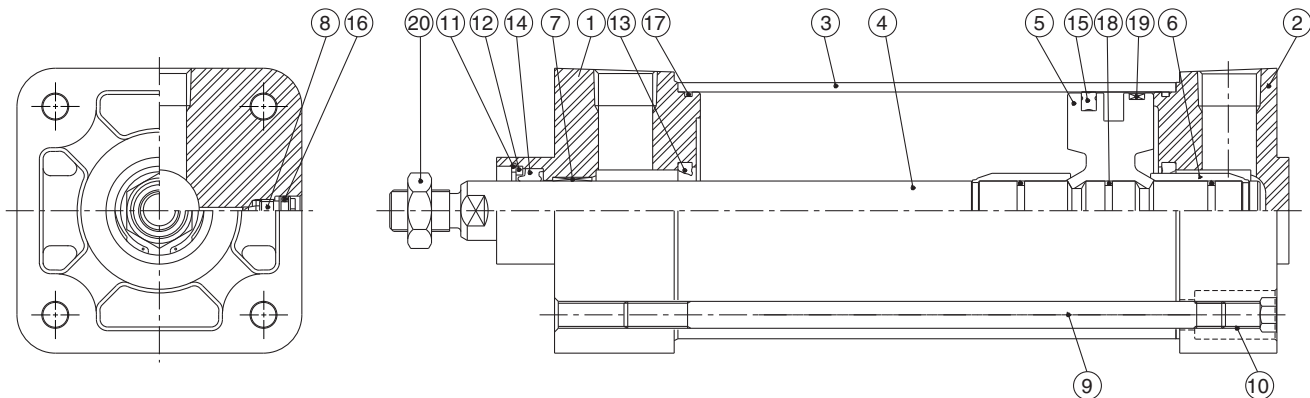

Parts List

No.	Description	Material	150	200	250	325	400	
1	Rod Cover	Aluminum alloy	NCA150-02AQ6308-S	NCA200-02AQ6309-S	NCA250-02AQ6310-S	NCA325-02AQ6311-S	NCA400-02AQ6312-S	
2	Head Cover	Aluminum alloy	NCA150-03-Q6308-S	NCA200-03-Q6309-S	NCA250-03-Q6310-S	NCA325-03-Q6311-S	NCA400-03-Q6312-S	
3	Cylinder Tube	Aluminum alloy	Please see below for How to Order Cylinder Tube.					
4	Piston Rod	Carbon steel	Available only as an Assembled Item. Please see below for How to Order Piston Rod Assembly.					
5	Piston	Aluminum alloy	Available only as an Assembled Item. Please see below for How to Order Piston Rod Assembly.					
6	Cushion Sphere	Aluminum alloy	Available only as an Assembled Item. Please see below for How to Order Piston Rod Assembly.					
7	Rod Bushing	Bronze casting	Available only as an Assembly Item. Please see Rod/Head Cover.					
8	Cushion Valve	Carbon steel	NC1A150-10-124			NC1A325-10-125		
9	Tie Rod	Carbon steel	Please see below for How to Order Tie Rod.					
10	Tie Rod Nut	Carbon steel	NCA150-13-Q6308	NCA200-13-Q6309		NCA325-13-Q6311	NCA325-13-Q6311	
11	Retaining Ring	Carbon steel	5008-93			5008-131		
12	Rod Seal Retainer	Resin	NCA150-31-Q6308	NCA150-31-Q6308	NCA150-31-Q6308	NCA325-31-Q6311	NCA325-31-Q6311	
13*	Cushion Seal	NBR	Available only as an Assembled Item. Please see below for How to Order Seal Kit.					
14*	Rod Seal	NBR	Available only as an Assembled Item. Please see below for How to Order Seal Kit.					
15*	Piston Seal	NBR	Available only as an Assembled Item. Please see below for How to Order Seal Kit.					
16*	Cushion Valve Seal	NBR	Available only as an Assembled Item. Please see below for How to Order Seal Kit.					
17*	Cylinder Tube Gasket	NBR	Available only as an Assembled Item. Please see below for How to Order Seal Kit.					
18	Piston Gasket	NBR	Available only as an Assembled Item. Please see below for How to Order Piston Rod Assembly.					
19	Wear Ring	Resin	Available only as an Assembled Item. Please see below for How to Order Piston Rod Assembly.					
20	Jam Nut	Carbon steel	JM-045	JM-045	JM-045	JM-10	JM-10	

*Components include in a seal kit.

How To Order Seal Kits

NC1A **W** **150** - PS -

Option • Nil Single rod
W Double rod
K* Non-rotating

Bore • 150
 200
 250
 325
 400

Special Options • **XB5***** Over sized rod
XB6*** High temperature
XB7*** Low temperature
XB5B6*** Oversized w/ high temperature*
XC11 Dual Operation/Single Rod**

* available for 150, 200 and 250 bores only
 ** use single rod designation when ordering XC11 kit
 Note: XC10 seal kit order 2 single rod kits
 *** not available with K option

How To Order Piston Rod Assembly Double Acting Single Rod

NCA1 **150** - 26A - **0400**

Bore • 150
 200
 250
 325
 400

Stroke • (In Inches and Hundredths of Inches)

How To Order Tie Rods

NC1A **150** - **11** - **2759** - **0400**

Applicable Bore	Bore	Tie Rod Size	Stroke (In Inches and Hundredths of Inches)
150	150	2759	
200	200	2760	
250	200	2760	
325	325	2761	
400	325	2761	

Note: Quantity is one piece. Not applicable for types: Double rod (W), Trunnion (T), XC8, XC9, XC10, XC11, Over sized rod (XB5) with front mounts. Please consult your local SMC sales office.

How To Order Cylinder Tube Double Acting Single Rod

NC1A **150** - 04 - **0400**

Bore • 150
 200
 250
 325
 400

Stroke • (In Inches and Hundredths of Inches)

Basic Mounting Type NC A1B (MX0 Mounting Style)

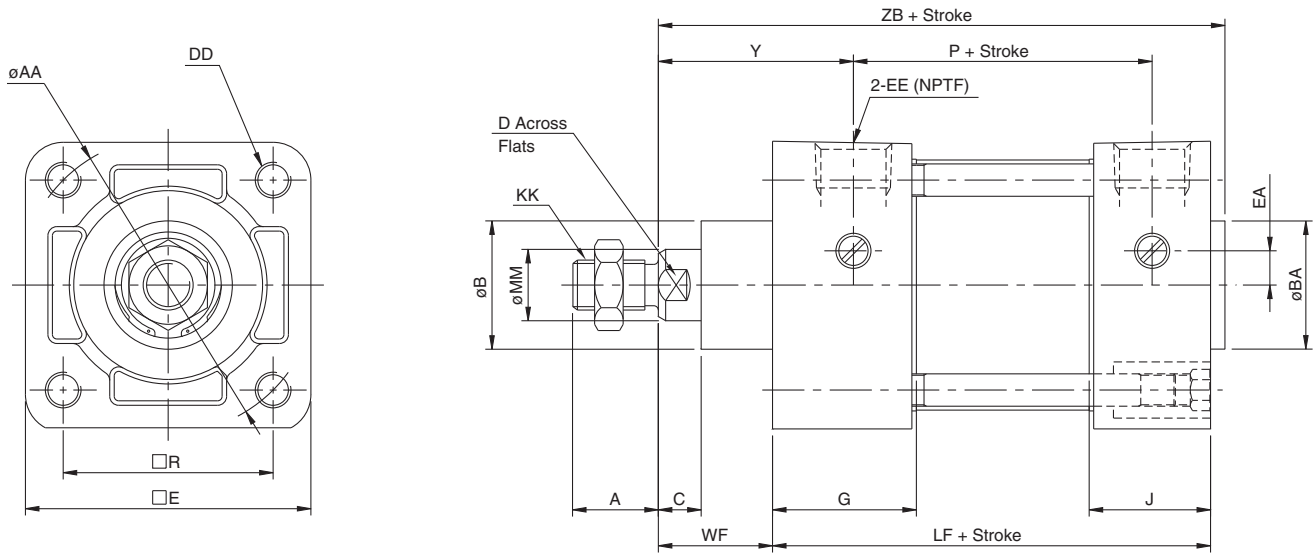

(in)

Bore (in)	MM	KK	A	AA	B	BA	C	D	DD	E	EA	EE	G	J	R	WF	Y	LF	P	ZB
150 (1.5")	5/8	7/16-20	3/4	2.02	1 1/8	1 1/8	3/8	9/16	1/4-28	2	0.3	3/8	1.26	1.1	1.43	1	1.71	3 5/8	2.36	4 3/4
200 (2")	5/8	7/16-20	3/4	2.6	1 1/8	1 1/8	3/8	9/16	5/16-24	2 1/2	0.3	3/8	1.26	1.06	1.84	1	1.71	3 5/8	2.4	4 3/4
250 (2.5")	5/8	7/16-20	3/4	3.1	1 1/8	1 1/8	3/8	9/16	5/16-24	3	0	3/8	1.3	1.06	2.19	1	1.75	3 3/4	2.48	4 7/8
325 (3.25")	1	3/4-16	1 1/8	3.9	1 1/2	1 1/2	1/2	7/8	3/8-24	3 3/4	0	1/2	1.57	1.18	2.76	1 3/8	2.34	4 1/4	2.72	5 53/64
400 (4")	1	3/4-16	1 1/8	4.7	1 1/2	1 1/2	1/2	7/8	3/8-24	4 1/2	0	1/2	1.57	1.18	3.32	1 3/8	2.34	4 1/4	2.72	5 53/64

Foot Mounting Type NC A1L (MS1 Mounting Style)

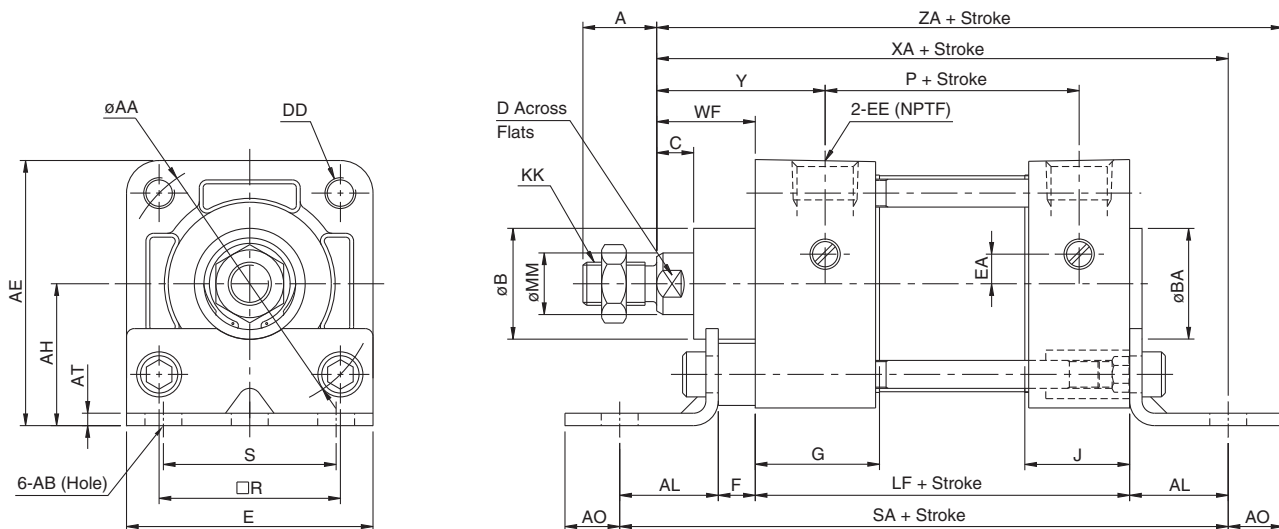

(in)

Bore (in)	MM	KK	A	AA	AB	AE	AH	AL	AO	AT	B	BA	C	D	DD	E	EA	EE	F	G	J	R	S	WF	Y	P	LF	SA	XA	ZA
150 (1.5")	5/8	7/16-20	3/4	2.02	3/8	2 3/16	1 3/16	1	7/16	1/8	1 1/8	1 1/8	3/8	9/16	1/4-28	2	0.3	3/8	3/8	1.26	1.1	1.43	1 1/4	1	1.71	2.36	3 5/8	6	5 5/8	6 1/16
200 (2")	5/8	7/16-20	3/4	2.6	3/8	2 11/16	1 7/16	1	9/16	1/8	1 1/8	1 1/8	3/8	9/16	5/16-24	2 1/2	0.3	3/8	3/8	1.26	1.06	1.84	1 3/4	1	1.71	2.4	3 5/8	6	5 5/8	6 3/16
250 (2.5")	5/8	7/16-20	3/4	3.1	3/8	3 1/8	1 5/8	1	9/16	1/8	1 1/8	1 1/8	3/8	9/16	5/16-24	3	0	3/8	3/8	1.3	1.06	2.19	2 1/4	1	1.75	2.48	3 3/4	6 1/8	5 3/4	6 5/16
325 (3.25")	1	3/4-16	1 1/8	3.9	1/2	3 13/16	1 15/16	1 1/4	3/4	11/64	1 1/2	1 1/2	1/2	7/8	3/8-24	3 3/4	0	1/2	5/8	1.57	1.18	2.76	2 3/4	1 3/8	2.34	2.72	4 1/4	7 3/8	6 7/8	7 5/8
400 (4")	1	3/4-16	1 1/8	4.7	1/2	4 1/2	2 1/4	1 1/4	3/4	15/64	1 1/2	1 1/2	1/2	7/8	3/8-24	4 1/2	0	1/2	5/8	1.57	1.18	3.32	3 1/2	1 3/8	2.34	2.72	4 1/4	7 3/8	6 7/8	7 5/8

Front Flange Mounting Type NC \square A1F (MF1 Mounting Style)

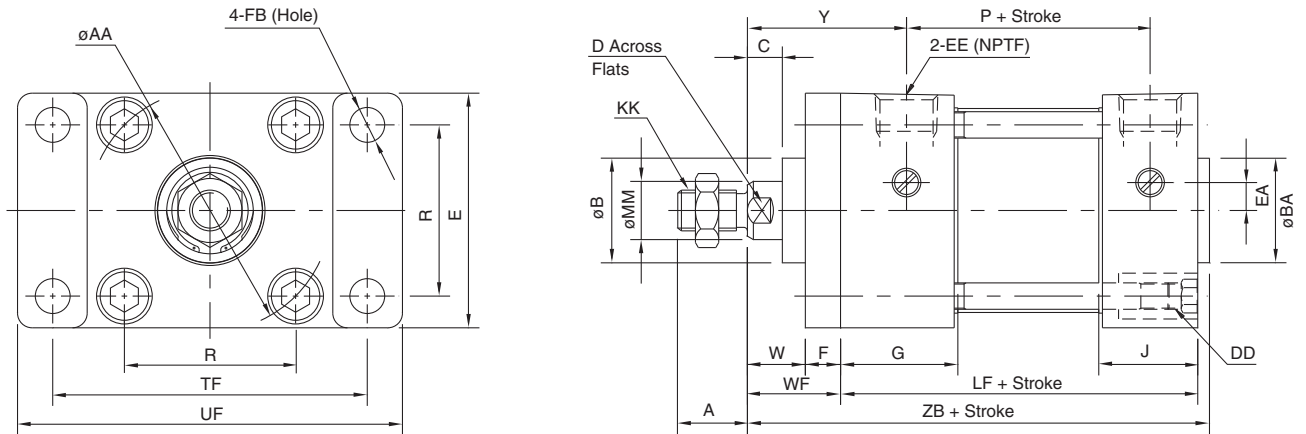

(in)

Bore (in)	MM	KK	A	AA	B	BA	C	D	DD	E	EA	EE	F	FB	G	J	R	TF	UF	W	WF	Y	LF	P	ZB
150 (1.5")	5/8	7/16-20	3/4	2.02	1 1/8	1 1/8	3/8	9/16	1/4-28	2	0.3	3/8	3/8	5/16	1.26	1.1	1.43	2 3/4	3 3/8	5/8	1	1.71	3 5/8	2.36	4 3/4
200 (2")	5/8	7/16-20	3/4	2.6	1 1/8	1 1/8	3/8	9/16	5/16-24	2 1/2	0.3	3/8	3/8	3/8	1.26	1.06	1.84	3 3/8	4 1/8	5/8	1	1.71	3 5/8	2.4	4 3/4
250 (2.5")	5/8	7/16-20	3/4	3.1	1 1/8	1 1/8	3/8	9/16	5/16-24	3	0	3/8	3/8	3/8	1.3	1.06	2.19	3 7/8	4 5/8	5/8	1	1.75	3 3/4	2.48	4 7/8
325 (3.25")	1	3/4-16	1 1/8	3.9	1 1/2	1 1/2	1/2	7/8	3/8-24	3 3/4	0	1/2	5/8	7/16	1.57	1.18	2.76	4 11/16	5 1/2	3/4	1 3/8	2.34	4 1/4	2.72	5 53/64
400 (4")	1	3/4-16	1 1/8	4.7	1 1/2	1 1/2	1/2	7/8	3/8-24	4 1/2	0	1/2	5/8	7/16	1.57	1.18	3.32	5 7/16	6 1/4	3/4	1 3/8	2.34	4 1/4	2.72	5 53/64

Rear Flange Mounting Type NC \square A1G (MF2 Mounting Style)

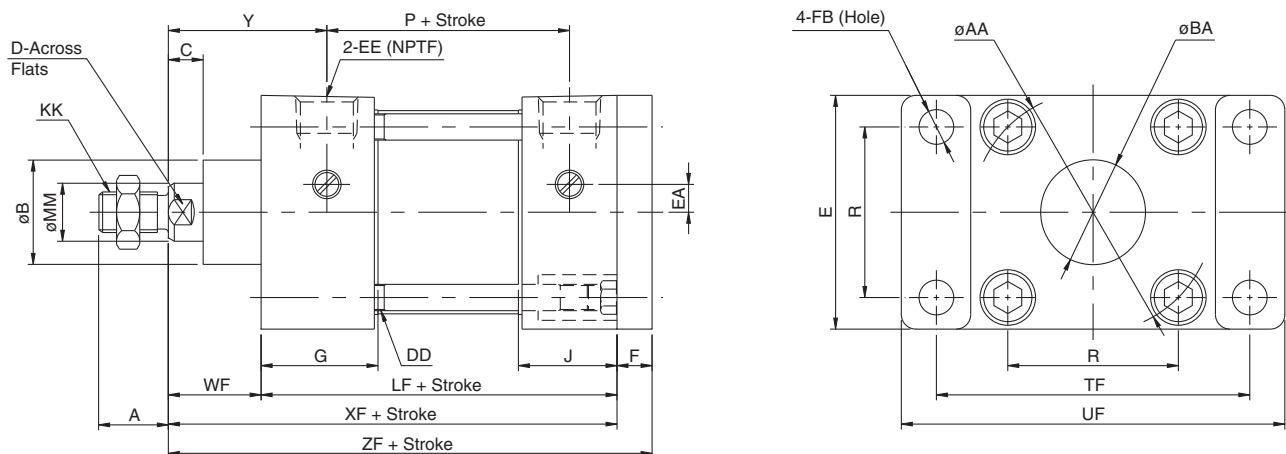

(in)

Bore (in)	MM	KK	A	AA	B	BA	C	D	DD	E	EA	EE	F	FB	G	J	R	TF	UF	WF	Y	P	XF	ZF
150 (1.5")	5/8	7/16-20	3/4	2.02	1 1/8	1 1/8	3/8	9/16	1/4-28	2	0.3	3/8	3/8	5/16	1.26	1.1	1.43	2 3/4	3 3/8	1	1.71	2.36	4 5/8	5
200 (2")	5/8	7/16-20	3/4	2.6	1 1/8	1 1/8	3/8	9/16	5/16-24	2 1/2	0.3	3/8	3/8	3/8	1.26	1.06	1.84	3 3/8	4 1/8	1	1.71	2.4	4 5/8	5
250 (2.5")	5/8	7/16-20	3/4	3.1	1 1/8	1 1/8	3/8	9/16	5/16-24	3	0	3/8	3/8	3/8	1.3	1.06	2.19	3 7/8	4 5/8	1	1.75	2.48	4 3/4	5 1/8
325 (3.25")	1	3/4-16	1 1/8	3.9	1 1/2	1 1/2	1/2	7/8	3/8-24	3 3/4	0	1/2	5/8	7/16	1.57	1.18	2.76	4 11/16	5 1/2	1 3/8	2.34	2.72	5 5/8	6 1/4
400 (4")	1	3/4-16	1 1/8	4.7	1 1/2	1 1/2	1/2	7/8	3/8-24	4 1/2	0	1/2	5/8	7/16	1.57	1.18	3.32	5 7/16	6 1/4	1 3/8	2.34	2.72	5 5/8	6 1/4

Side Tapped Mounting Type NC A1R (MS4 Mounting Style)

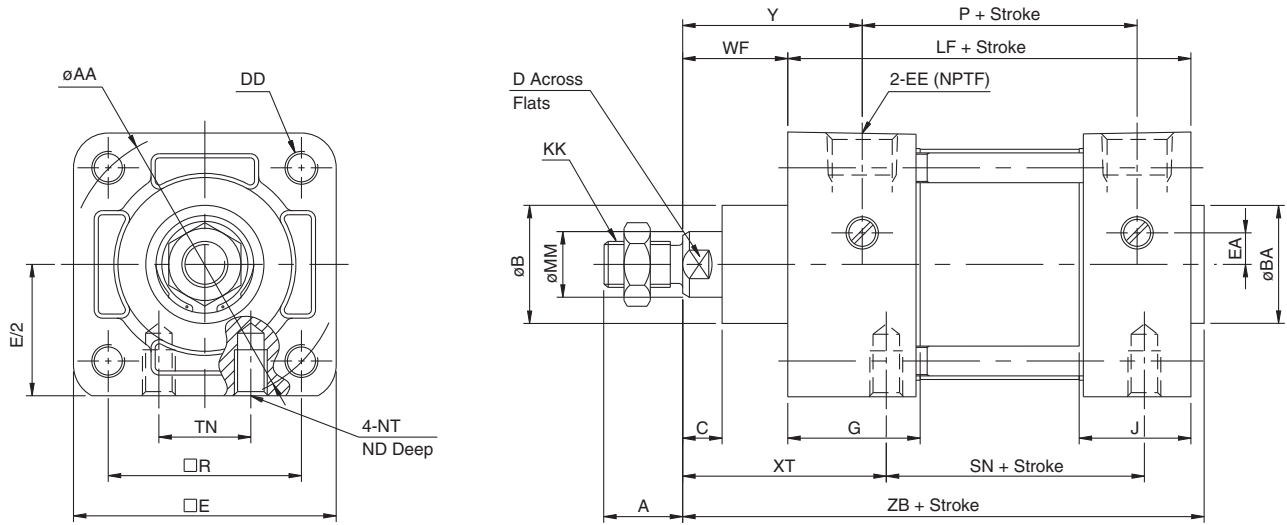

(in)

Bore (in)	MM	KK	A	AA	B	BA	C	D	DD	E	E/2	EA	EE	G	J	ND	NT	R	TN	WF	XT	Y	LF	P	SN	ZB
150 (1.5")	5/8	7/16-20	3/4	2.02	1 1/8	1 1/8	3/8	9/16	1/4-28	2	1	0.3	3/8	1.26	1.1	9/32	1/4-20	1.43	5/8	1	1 15/16	1.71	3 5/8	2.36	2 1/4	4 3/4
200 (2")	5/8	7/16-20	3/4	2.6	1 1/8	1 1/8	3/8	9/16	5/16-24	2 1/2	1 1/4	0.3	3/8	1.26	1.06	7/16	5/16-18	1.84	7/8	1	1 15/16	1.71	3 5/8	2.4	2 1/4	4 3/4
250 (2.5")	5/8	7/16-20	3/4	3.1	1 1/8	1 1/8	3/8	9/16	5/16-24	3	1 1/2	0	3/8	1.3	1.06	19/32	3/8-16	2.19	1 1/4	1	1 15/16	1.75	3 3/4	2.48	2 3/8	4 7/8
325 (3.25")	1	3/4-16	1 1/8	3.9	1 1/2	1 1/2	1/2	7/8	3/8-24	3 3/4	1 7/8	0	1/2	1.57	1.18	5/8	1/2-13	2.76	1 1/2	1 3/8	2 7/16	2.34	4 1/4	2.72	2 5/8	5 53/64
400 (4")	1	3/4-16	1 1/8	4.7	1 1/2	1 1/2	1/2	7/8	3/8-24	4 1/2	2 1/4	0	1/2	1.57	1.18	5/8	1/2-13	3.32	2 1/16	1 3/8	2 7/16	2.34	4 1/4	2.72	2 5/8	5 53/64

Double Detachable Rear Clevis Mounting Type NC A1D (MP2 Mounting Style)

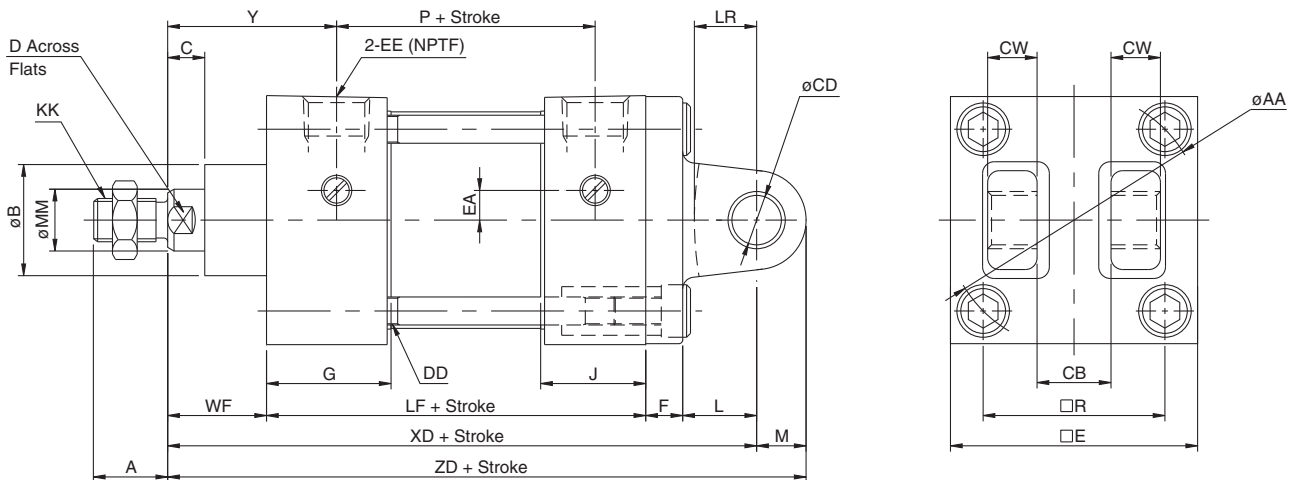

(in)

Bore (in)	MM	KK	A	AA	B	C	CB	CD	CW	D	DD	E	EA	EE	F	G	J	L	LR	M	R	WF	XD	Y	LF	P	ZD
150 (1.5")	5/8	7/16-20	3/4	2.02	1 1/8	3/8	3/4	1/2	1/2	9/16	1/4-28	2	0.3	3/8	3/8	1.26	1.1	3/4	5/8	1/2	1.43	1	5 3/4	1.71	3 5/8	2.36	6 1/4
200 (2")	5/8	7/16-20	3/4	2.6	1 1/8	3/8	3/4	1/2	1/2	9/16	5/16-24	2 1/2	0.3	3/8	3/8	1.26	1.06	3/4	5/8	1/2	1.84	1	5 3/4	1.71	3 5/8	2.4	6 1/4
250 (2.5")	5/8	7/16-20	3/4	3.1	1 1/8	3/8	3/4	1/2	1/2	9/16	5/16-24	3	0	3/8	3/8	1.3	1.06	3/4	5/8	1/2	2.19	1	5 7/8	1.75	3 3/4	2.48	6 3/8
325 (3.25")	1	3/4-16	1 1/8	3.9	1 1/2	1/2	1 1/4	3/4	5/8	7/8	3/8-24	3 3/4	0	1/2	5/8	1.57	1.18	1 1/4	1	3/4	2.76	1 3/8	7 1/2	2.34	4 1/4	2.72	8 1/4
400 (4")	1	3/4-16	1 1/8	4.7	1 1/2	1/2	1 1/4	3/4	5/8	7/8	3/8-24	4 1/2	0	1/2	5/8	1.57	1.18	1 1/4	1	3/4	3.32	1 3/8	7 1/2	2.34	4 1/4	2.72	8 1/4

Center Trunnion Mounting Type NC A1T (MT4 Mounting Style)

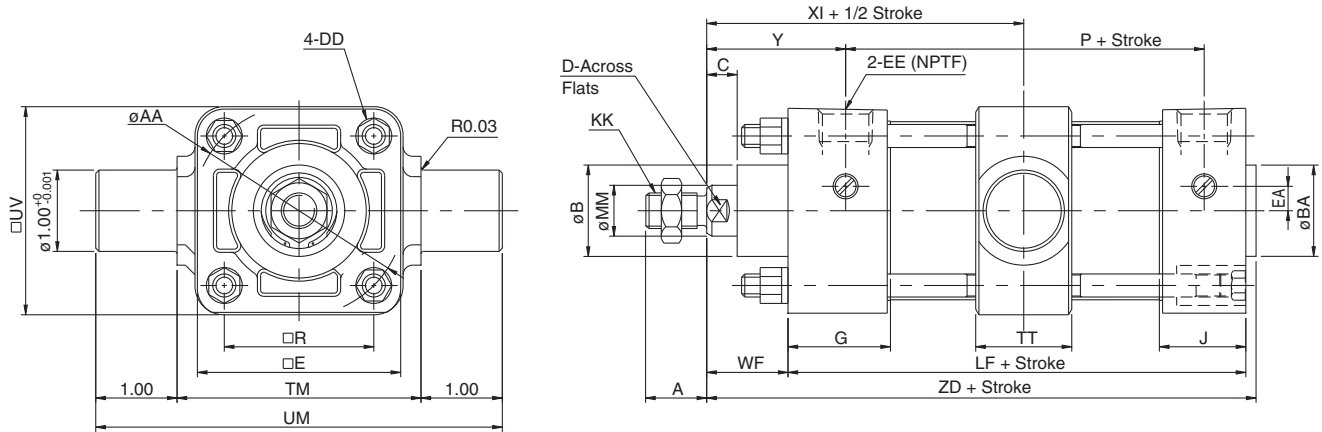

(in)

Bore (in)	MM	KK	A	AA	B	BA	C	D	DD	E	EA	EE	G	J	R	TM	TT	UM	UV	WF	Y	P	LF	XI	ZB
150 (1.5")	5/8	7/16-20	3/4	2.02	1 1/8	1 1/8	3/8	9/16	1/4-28	2	0.3	3/8	1.26	1.1	1.43	2.5	1.18	4.5	2	1	1.71	2.36	3 5/8	2.89	4 3/4
200 (2")	5/8	7/16-20	3/4	2.6	1 1/8	1 1/8	3/8	9/16	5/16-24	2 1/2	0.3	3/8	1.26	1.06	1.84	3	1.18	5	2.56	1	1.71	2.4	3 5/8	2.91	4 3/4
250 (2.5")	5/8	7/16-20	3/4	3.1	1 1/8	1 1/8	3/8	9/16	5/16-24	3	0	3/8	1.3	1.06	2.19	3.5	1.18	5.5	3.39	1	1.75	2.48	3 3/4	2.99	4 7/8
325 (3.25")	1	3/4-16	1 1/8	3.9	1 1/2	1 1/2	1/2	7/8	3/8-24	3 3/4	0	1/2	1.57	1.18	2.76	4.5	1.34	6.5	4.33	1 3/8	2.34	2.72	4 1/4	3.7	5 53/64
400 (4")	1	3/4-16	1 1/8	4.7	1 1/2	1 1/2	1/2	7/8	3/8-24	4 1/2	0	1/2	1.57	1.18	3.32	5.25	1.57	7.25	5.12	1 3/8	2.34	2.72	4 1/4	3.74	5 53/64

Single Detachable Rear Clevis Mounting Type NC A1C (MP4 Mounting Style)

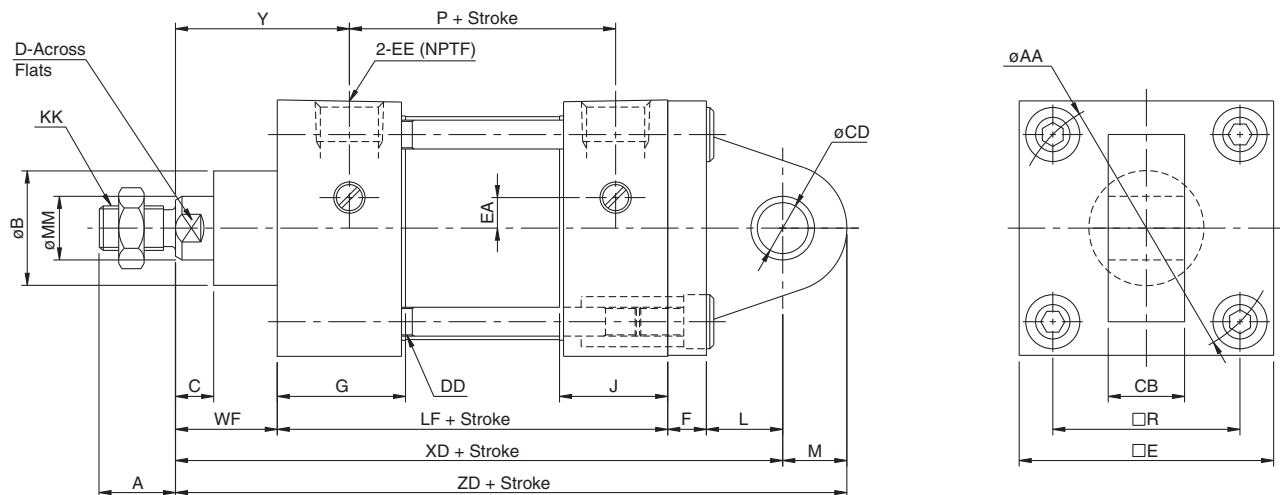

Bore (in)	MM	KK	A	AA	B	C	CB	CD	D	DD	E	EA	EE	F	G	J	L	M	R	WF	XD	Y	LF	P	ZD
150 (1.5")	5/8	7/16-20	3/4	2.02	1 1/8	3/8	3/4	1/2	9/16	1/4-28	2	0.3	3/8	3/8	1.26	1.1	3/4	0.63	1.43	1	5 3/4	1.71	3 5/8	2.36	6 3/8
200 (2")	5/8	7/16-20	3/4	2.6	1 1/8	3/8	3/4	1/2	9/16	5/16-24	2 1/2	0.3	3/8	3/8	1.26	1.06	3/4	0.63	1.84	1	5 3/4	1.71	3 5/8	2.4	6 3/8
250 (2.5")	5/8	7/16-20	3/4	3.1	1 1/8	3/8	3/4	1/2	9/16	5/16-24	3	0	3/8	3/8	1.3	1.06	3/4	0.63	2.19	1	5 7/8	1.75	3 3/4	2.48	6 1/2
325 (3.25")	1	3/4-16	1 1/8	3.9	1 1/2	1/2	1 1/4	3/4	7/8	3/8-24	3 3/4	0	1/2	5/8	1.57	1.18	1 1/4	0.87	2.76	1 3/8	7 1/2	2.34	4 1/4	2.72	8 3/8
400 (4")	1	3/4-16	1 1/8	4.7	1 1/2	1/2	1 1/4	3/4	7/8	3/8-24	4 1/2	0	1/2	5/8	1.57	1.18	1 1/4	0.87	3.32	1 3/8	7 1/2	2.34	4 1/4	2.72	8 3/8

Double Rear Clevis Mounting Type NC A1X (MP1 Mounting Style)

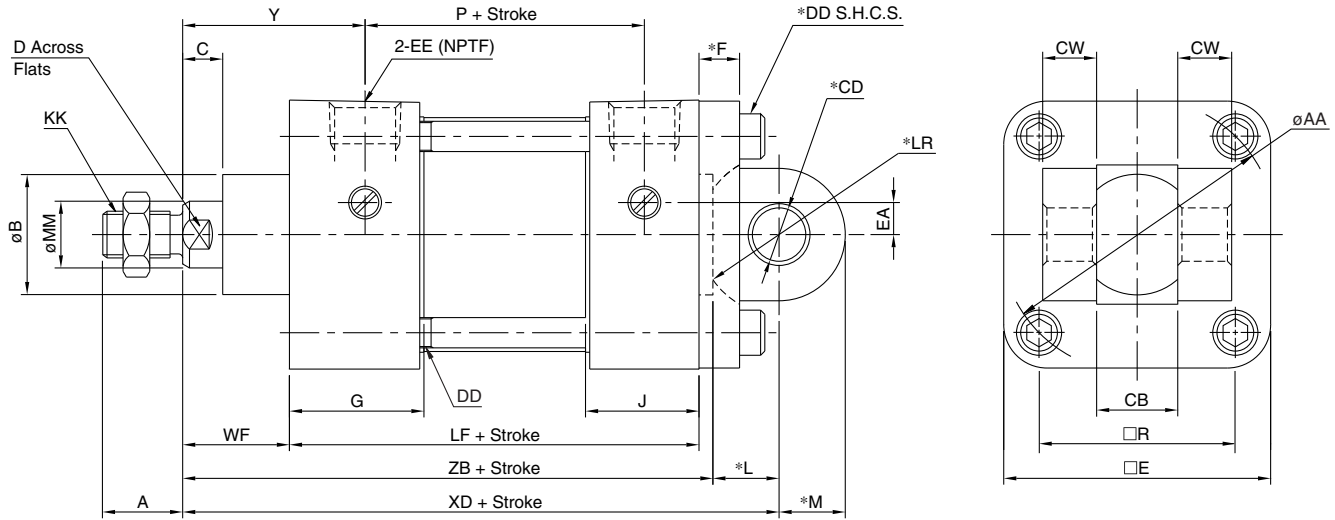

(in)

Bore (in)	MM	KK	A	AA	B	C	CB	CD	CW	D	DD	E	EA	EE	F	G	J	L	LR	R	M	WF	XD	Y	LF	P	ZB
150 (1.5")	5/8	7/16-20	3/4	2.02	1 1/8	3/8	3/4	1/2	1/2	9/16	1/4-28	2	0.3	3/8	3/8	1.26	1.1	0.62	0.75	1.43	0.62	1	5 3/8	1.71	3 5/8	2.36	4.75
200 (2")	5/8	7/16-20	3/4	2.6	1 1/8	3/8	3/4	1/2	1/2	9/16	5/16-24	2 1/2	0.3	3/8	3/8	1.26	1.06	0.62	0.75	1.84	0.62	1	5 3/8	1.71	3 5/8	2.4	4.75
250 (2.5")	5/8	7/16-20	3/4	3.1	1 1/8	3/8	3/4	1/2	1/2	9/16	5/16-24	3	0	3/8	3/8	1.3	1.06	0.62	0.75	2.19	0.62	1	5 1/2	1.75	3 3/4	2.48	4.88
325 (3.25")	1	3/4-16	1 1/8	3.9	1 1/2	1/2	1 1/4	3/4	5/8	7/8	3/8-24	3 3/4	0	1/2	5/8	1.57	1.18	1.05	1.25	2.76	0.87	1 3/8	6 7/8	2.34	4 1/4	2.72	5.83
400 (4")	1	3/4-16	1 1/8	4.7	1 1/2	1/2	1 1/4	3/4	5/8	7/8	3/8-24	4 1/2	0	1/2	5/8	1.57	1.18	1.05	1.25	3.32	0.87	1 3/8	6 7/8	2.34	4 1/4	2.72	5.83

Note: Mounting dimensions are the same as NFPA (MP1) except where marked. (*)

Side Lug Mounting Type NC A1S (MS2 Mounting Style)

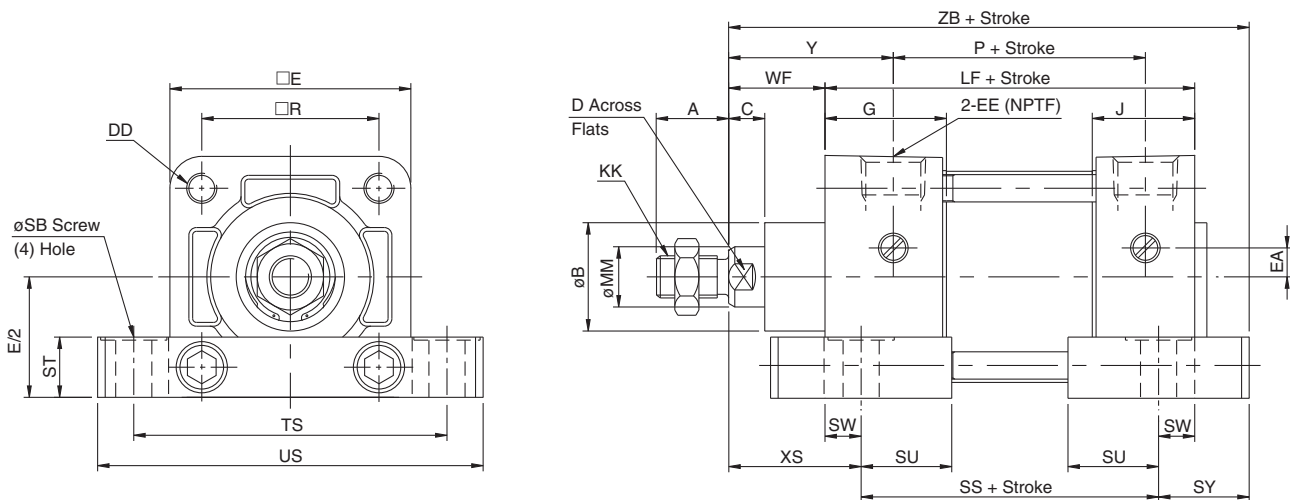

(in)

Bore (in)	MM	KK	A	B	C	D	DD	E	EA	EE	G	J	LF	P	R	SB	SS	ST	SU	SW	SY	TS	US	WF	XS	Y	ZB
150 (1.5")	5/8	7/16-20	3/4	1 1/8	3/8	9/16	1/4-28	2	0.3	3/8	1.26	1.1	3.63	2.36	1.43	3/8	2.88	5/8	0.94	3/8	0.94	2.75	3.50	1	1.38	1.71	5.19
200 (2")	5/8	7/16-20	3/4	1 1/8	3/8	9/16	5/16-24	2 1/2	0.3	3/8	1.26	1.06	3.63	2.4	1.84	3/8	2.88	5/8	0.94	3/8	0.94	3.25	4	1	1.38	1.71	5.19
250 (2.5")	5/8	7/16-20	3/4	1 1/8	3/8	9/16	5/16-24	3	0	3/8	1.3	1.06	3.75	2.48	2.19	3/8	3	3/4	0.94	3/8	0.94	3.75	4.50	1	1.38	1.75	5.31
325 (3.25")	1	3/4-16	1 1/8	1 1/2	1/2	7/8	3/8-24	3 3/4	0	1/2	1.57	1.18	4.25	2.72	2.76	1/2	3.25	1	1.25	1/2	1.25	4.75	5.75	1 3/8	1.88	2.34	6.38
400 (4")	1	3/4-16	1 1/8	1 1/2	1/2	7/8	3/8-24	4 1/2	0	1/2	1.57	1.18	4.25	2.72	3.32	1/2	3.25	1	1.25	1/2	1.25	5.50	6.50	1 3/8	1.88	2.34	6.38

Rod Trunnion Mounting Type NC A1U (MT1 Mounting Style)

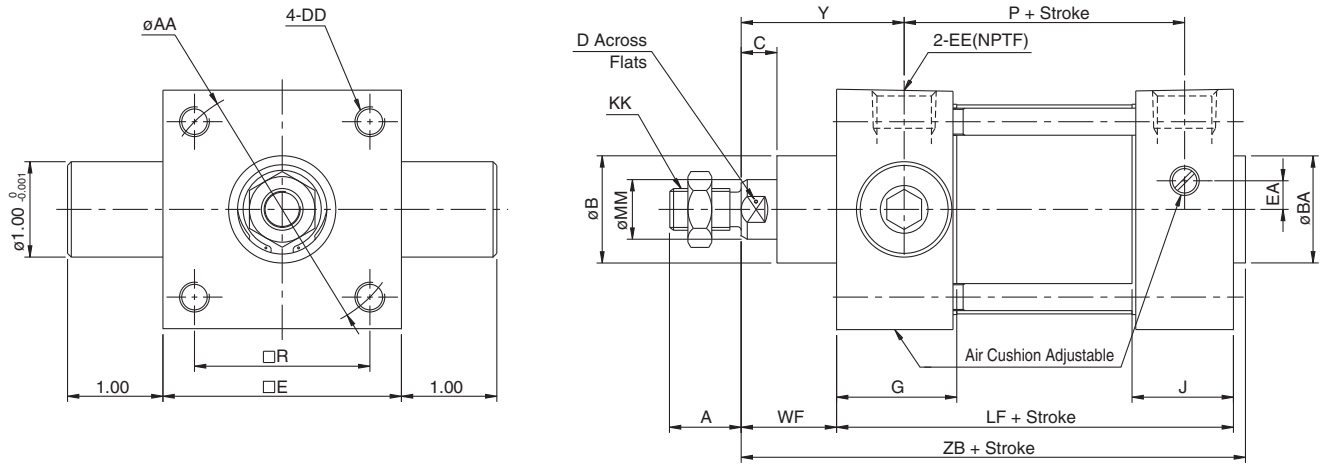

(in)

Bore (in)	MM	KK	A	AA	B	BA	C	D	DD	E	EA	EE	G	J	R	WF	Y	LF	P	ZB
150 (1.5")	5/8	7/16-20	3/4	2.02	1 1/8	1 1/8	3/8	9/16	1/4-28	2	0.3	3/8	1.26	1.1	1.43	1	1.71	3 5/8	2.36	4.75
200 (2")	5/8	7/16-20	3/4	2.6	1 1/8	1 1/8	3/8	9/16	5/16-24	2 1/2	0.3	3/8	1.26	1.06	1.84	1	1.71	3 5/8	2.4	4.75
250 (2.5")	5/8	7/16-20	3/4	3.1	1 1/8	1 1/8	3/8	9/16	5/16-24	3	0	3/8	1.3	1.06	2.19	1	1.75	3 3/4	2.48	4.88
325 (3.25")	1	3/4-16	1 1/8	3.9	1 1/2	1 1/2	1/2	7/8	3/8-24	3 3/4	0	1/2	1.57	1.18	2.76	1 3/8	2.34	4 1/4	2.72	5.83
400 (4")	1	3/4-16	1 1/8	4.7	1 1/2	1 1/2	1/2	7/8	3/8-24	4 1/2	0	1/2	1.57	1.18	3.32	1 3/8	2.34	4 1/4	2.72	5.83

Head Trunnion Mounting Type NC A1J (MT2 Mounting Style)

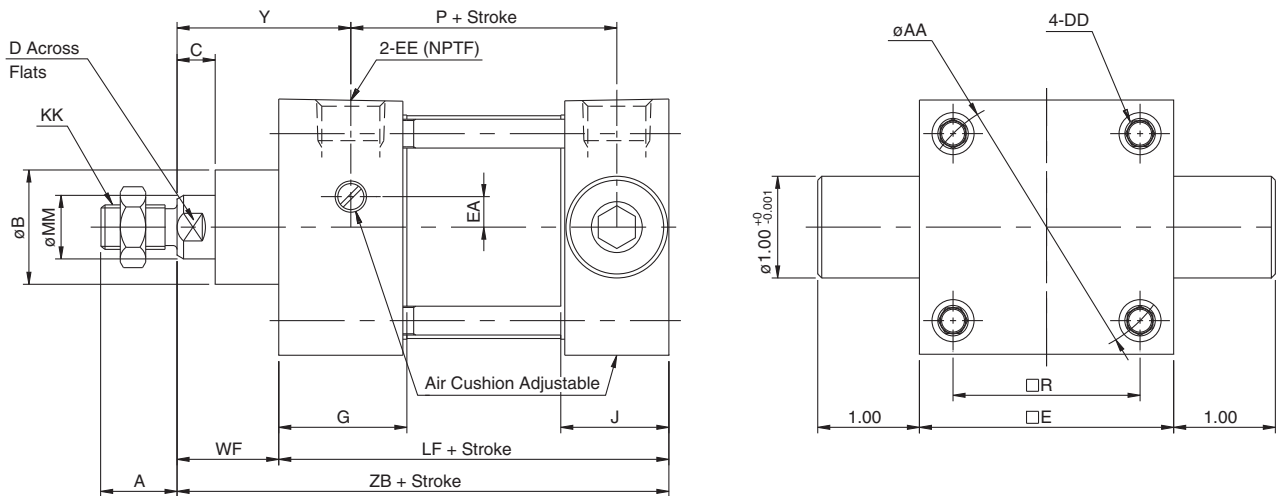

(in)

Bore (in)	MM	KK	A	AA	B	C	D	DD	E	EA	EE	G	J	R	WF	Y	LF	P	ZB
150 (1.5")	5/8	7/16-20	3/4	2.02	1 1/8	3/8	9/16	1/4-28	2	0.3	3/8	1.26	1.23	1.43	1	1.71	3.75	2.36	4.75
200 (2")	5/8	7/16-20	3/4	2.6	1 1/8	3/8	9/16	5/16-24	2 1/2	0.3	3/8	1.26	1.19	1.84	1	1.71	3.75	2.4	4.75
250 (2.5")	5/8	7/16-20	3/4	3.1	1 1/8	3/8	9/16	5/16-24	3	0	3/8	1.3	1.19	2.19	1	1.75	3.88	2.48	4.88
325 (3.25")	1	3/4-16	1 1/8	3.9	1 1/2	1/2	7/8	3/8-24	3 3/4	0	1/2	1.57	1.38	2.76	1 3/8	2.34	4.45	2.72	5.83
400 (4")	1	3/4-16	1 1/8	4.7	1 1/2	1/2	7/8	3/8-24	4 1/2	0	1/2	1.57	1.38	3.32	1 3/8	2.34	4.45	2.72	5.83

Specifications



- Standard with air cushion
- Auto-switch mounting available

Bore size (inch)	1.5	2	2.5	3.25	4
Media	Air				
Max. Operating Pressure	250 psi (17.5 kgf/cm ²)				
Min. Operating Pressure	8 psi (0.5 kgf/cm ²)				
Ambient and Media Temperature	40 to 140°F (5 to 60°C)				
Piston Speed	2 to 20 inch/sec (50 to 500mm/sec)				
Cushion	Air Cushion Standard				
Mounting Types	Basic, Foot, Flange, Center Trunnion, Rod Trunnion				

Standard Stroke List

(in)

Bore size	Standard Stroke
1.5"	1, 2, 3, 4, 5, 6, 8, 10, 12, 14, 16, 18, 20, 24
2", 2.5"	1, 2, 3, 4, 5, 6, 8, 10, 12, 14, 16, 18, 20, 24
3.25", 4"	1, 2, 3, 4, 5, 6, 8, 10, 12, 14, 16, 18, 20, 24, 28, 30

How To Order

NCDA1 W MOUNTING BORE - STROKE - SUFFIX

Ex: NCDA1WB 150-400

Auto-switch capable Double Rod

Double Rod – Basic Mounting Type NC A1WB

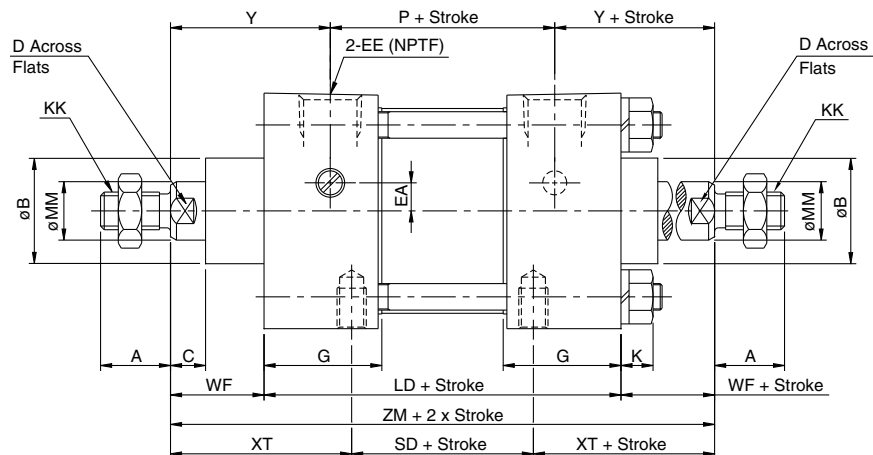
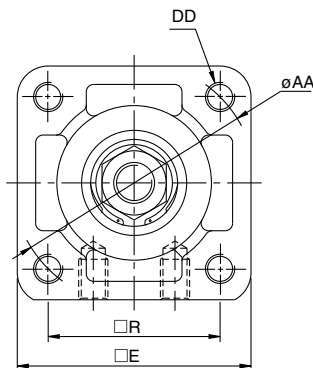

(in)

Bore (in)	MM	KK	A	AA	B	C	D	DD	E	EA	EE	G	K	LD	P	R	WF	Y	ZM	XT	SD
150 (1.5")	5/8	7/16-20	3/4	2.02	1 1/8	3/8	9/16	1/4-28	2	0.3	3/8	1.26	0.28	3.78	2.36	1.43	1	1.71	5.78	1 15/16	1.9
200 (2")	5/8	7/16-20	3/4	2.6	1 1/8	3/8	9/16	5/16-24	2 1/2	0.3	3/8	1.26	0.34	3.82	2.4	1.84	1	1.71	5.82	1 15/16	1.94
250 (2.5")	5/8	7/16-20	3/4	3.1	1 1/8	3/8	9/16	5/16-24	3	0	3/8	1.3	0.34	3.98	2.48	2.19	1	1.75	5.98	1 15/16	2.1
325 (3.25")	1	3/4-16	1 1/8	3.9	1 1/2	1/2	7/8	3/8-24	3 3/4	0	1/2	1.57	0.42	4.64	2.72	2.76	1 3/8	2.34	7.4	2 7/16	2.52
400 (4")	1	3/4-16	1 1/8	4.7	1 1/2	1/2	7/8	3/8-24	4 1/2	0	1/2	1.57	0.42	4.64	2.72	3.32	1 3/8	2.34	7.4	2 7/16	2.52

Double Rod – Foot Mounting Type NC A1WL

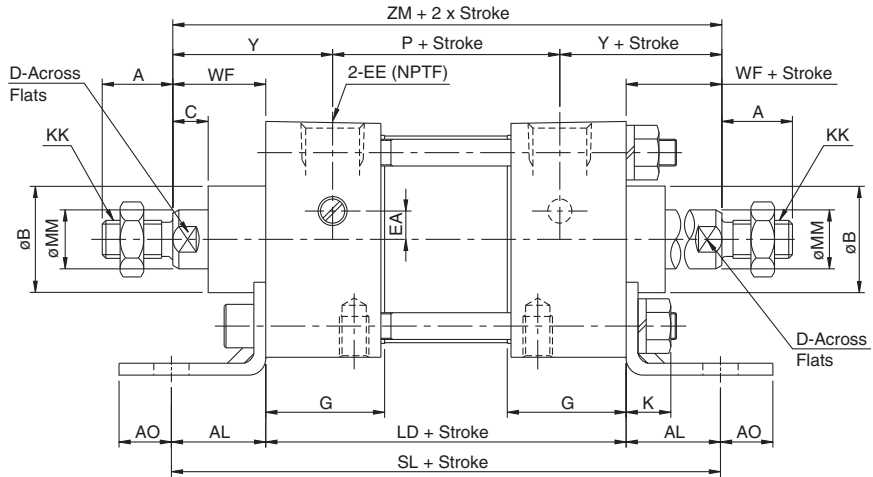
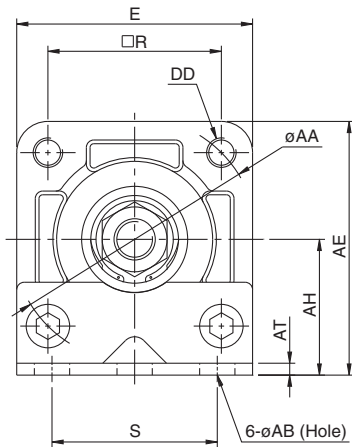

(in)

Bore (in)	MM	KK	A	AA	AB	AE	AH	AL	AO	AT	B	C	D	DD	E	EA	EE	G	K	S	WF	Y	P	R	LD	SL	ZM
150 (1.5")	5/8	7/16-20	3/4	2.02	3/8	2 3/16	1 3/16	1	7/16	1/8	1 1/8	3/8	9/16	1/4-28	2	0.3	3/8	1.26	0.41	1 1/4	1	1.71	2.36	1.43	3.78	5.78	5.78
200 (2")	5/8	7/16-20	3/4	2.6	3/8	2 11/16	1 7/16	1	9/16	1/8	1 1/8	3/8	9/16	5/16-24	2 1/2	0.3	3/8	1.26	0.47	1 3/4	1	1.71	2.4	1.84	3.82	5.82	5.82
250 (2.5")	5/8	7/16-20	3/4	3.1	3/8	3 1/8	1 5/8	1	9/16	1/8	1 1/8	3/8	9/16	5/16-24	3	0	3/8	1.3	0.47	2 1/4	1	1.75	2.48	2.19	3.98	5.98	5.98
325 (3.25")	1	3/4-16	1 1/8	3.9	1/2	3 13/16	1 15/16	1 1/4	3/4	11/64	1 1/2	1/2	7/8	3/8-24	3 3/4	0	1/2	1.57	0.59	2 3/4	1 3/8	2.34	2.72	2.76	4.64	7.14	7.40
400 (4")	1	3/4-16	1 1/8	4.7	1/2	4 1/2	2 1/4	1 1/4	3/4	15/64	1 1/2	1/2	7/8	3/8-24	4 1/2	0	1/2	1.57	0.65	3 1/2	1 3/8	2.34	2.72	3.32	4.64	7.14	7.40

Double Rod – Front Flange Mounting Type NC A1WF

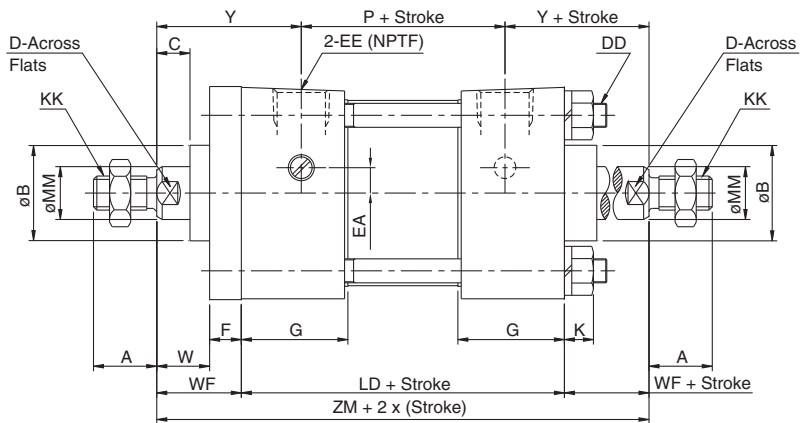
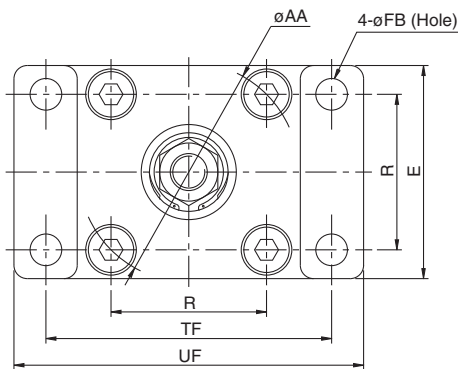

(in)

Bore (in)	MM	KK	A	AA	B	C	D	DD	E	EA	EE	F	FB	G	K	R	TF	UF	W	WF	Y	LD	P	ZM
150 (1.5")	5/8	7/16-20	3/4	2.02	1 1/8	3/8	9/16	1/4-28	2	0.3	3/8	3/8	5/16	1.26	0.28	1.43	2 3/4	3 3/8	5/8	1	1.71	3.78	2.36	5.78
200 (2")	5/8	7/16-20	3/4	2.6	1 1/8	3/8	9/16	5/16-24	2 1/2	0.3	3/8	3/8	3/8	1.26	0.34	1.84	3 3/8	4 1/8	5/8	1	1.71	3.82	2.4	5.82
250 (2.5")	5/8	7/16-20	3/4	3.1	1 1/8	3/8	9/16	5/16-24	3	0	3/8	3/8	3/8	1.3	0.34	2.19	3 7/8	4 5/8	5/8	1	1.75	3.98	2.48	5.98
325 (3.25")	1	3/4-16	1 1/8	3.9	1 1/2	1/2	7/8	3/8-24	3 3/4	0	1/2	5/8	7/16	1.57	0.42	2.76	4 11/16	5 1/2	3/4	1 3/8	2.34	4.64	2.72	7.40
400 (4")	1	3/4-16	1 1/8	4.7	1 1/2	1/2	7/8	3/8-24	4 1/2	0	1/2	5/8	7/16	1.57	0.42	3.32	5 7/16	6 1/4	3/4	1 3/8	2.34	4.64	2.72	7.40

Double Rod – Center Trunnion Mounting Type NC A1WT

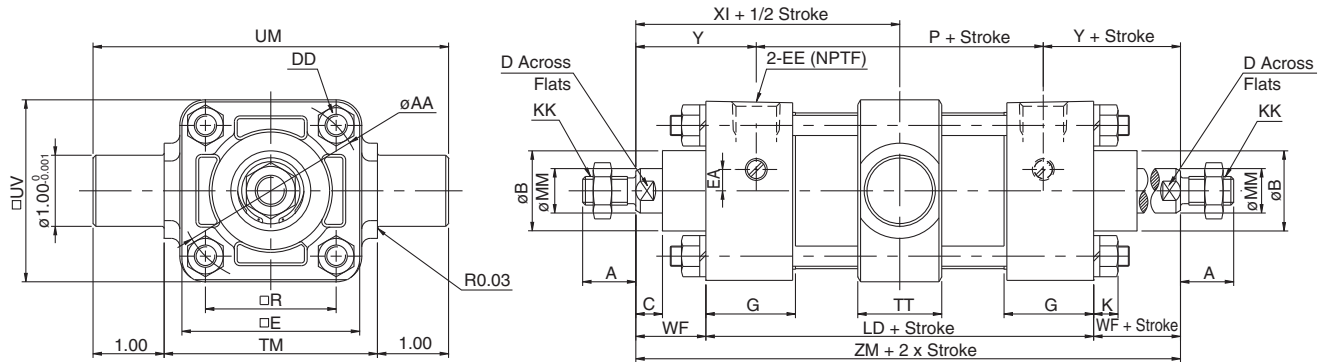

(in)

Bore (in)	MM	KK	A	AA	B	C	D	DD	E	EA	EE	G	K	R	TM	TT	UM	UV	WF	Y	P	LD	XI	ZM
150 (1.5")	5/8	7/16-20	3/4	2.02	1 1/8	3/8	9/16	1/4-28	2	0.3	3/8	1.26	0.281	1.43	2.5	1.18	4.5	2	1	1.71	2.36	3.78	2.89	5.78
200 (2")	5/8	7/16-20	3/4	2.6	1 1/8	3/8	9/16	5/16-24	2 1/2	0.3	3/8	1.26	0.343	1.84	3	1.18	5	2.56	1	1.71	2.40	3.82	2.91	5.82
250 (2.5")	5/8	7/16-20	3/4	3.1	1 1/8	3/8	9/16	5/16-24	3	0	3/8	1.30	0.343	2.19	3.5	1.18	5.5	3.39	1	1.75	2.48	3.98	2.99	5.98
325 (3.25")	1	3/4-16	1 1/8	3.9	1 1/2	1/2	7/8	3/8-16	3 3/4	0	1/2	1.57	0.421	2.76	4.5	1.34	6.5	4.33	1 3/8	2.34	2.72	4.64	3.70	7.40
400 (4")	1	3/4-16	1 1/8	4.7	1 1/2	1/2	7/8	3/8-16	4 1/2	0	1/2	1.57	0.421	3.32	5.25	1.57	7.25	5.12	1 3/8	2.34	2.72	4.64	3.74	7.40

Double Rod – Rod Trunnion Mounting Type NC A1WU

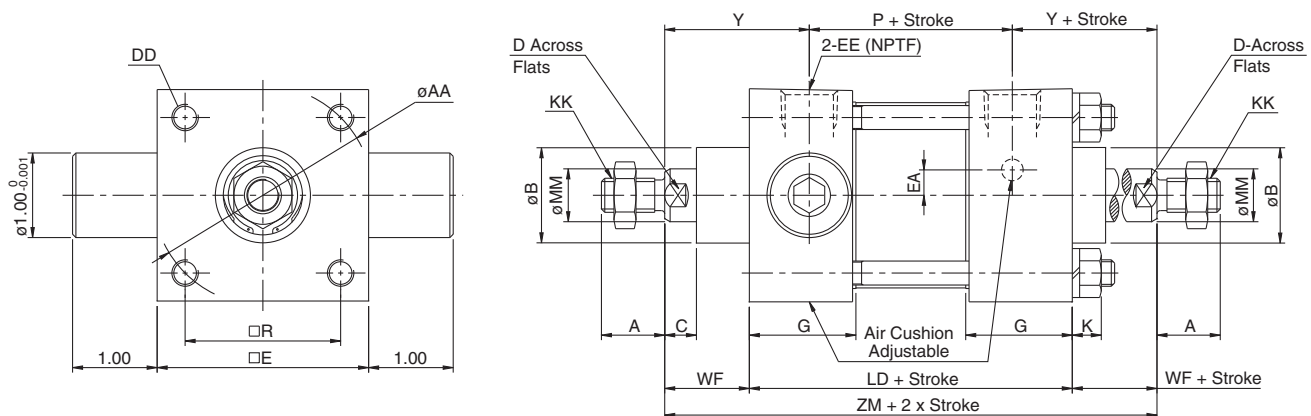

(in)

Bore (in)	MM	KK	A	AA	B	C	D	DD	E	EA	EE	G	K	R	WF	Y	LD	P	ZM
150 (1.5")	5/8	7/16-20	3/4	2.02	1 1/8	3/8	9/16	1/4-28	2	0.3	3/8	1.26	0.281	1.43	1	1.71	3.78	2.36	5.78
200 (2")	5/8	7/16-20	3/4	2.6	1 1/8	3/8	9/16	5/16-24	2 1/2	0.3	3/8	1.26	0.343	1.84	1	1.71	3.82	2.40	5.82
250 (2.5")	5/8	7/16-20	3/4	3.1	1 1/8	3/8	9/16	5/16-24	3	0	3/8	1.3	0.343	2.19	1	1.75	3.98	2.48	5.98
325 (3.25")	1	3/4-16	1 1/8	3.9	1 1/2	1/2	7/8	3/8-24	3 3/4	0	1/2	1.57	0.421	2.76	1 3/8	2.34	4.64	2.72	7.40
400 (4")	1	3/4-16	1 1/8	4.7	1 1/2	1/2	7/8	3/8-24	4 1/2	0	1/2	1.57	0.421	3.32	1 3/8	2.34	4.64	2.72	7.40

Specifications



- Non-rotating rod accuracy: $\pm 0.5^\circ$
- Auto switch mounting available

Bore size (inch)	1.5	2	2.5
Media	Air		
Max. Operating Pressure	250 psi (17.5 kgf/cm ²)		
Min. Operating Pressure	15 psi (1.05 kgf/cm ²)		
Ambient and Media Temperature	40 to 140°F (5 to 60°C)		
Piston Speed	2 to 20 inch/sec (50 to 500mm/sec)		
Cushion	Air Cushion Standard		
Rotation Torque Range	3.9 Lbs. in or less		
Non-Rotating Rod Accuracy	$\pm 0.5^\circ$		
Mounting Types	Basic, Foot, Flange, Side Tapped Center Trunnion, Rear Clevis, Side Lug		

Standard Stroke List

Bore size	Standard Stroke (in)
1.5"	1, 2, 3, 4, 5, 6, 8, 10, 12, 14, 16, 18, 20, 24
2", 2.5"	1, 2, 3, 4, 5, 6, 8, 10, 12, 14, 16, 18, 20, 24

How To Order

NCDA1 K MOUNTING BORE - STROKE - SUFFIX

Ex: NCDA1KB150-0400

Auto-switch capable

Non-Rotating Rod – Basic Mounting Type NC A1KB

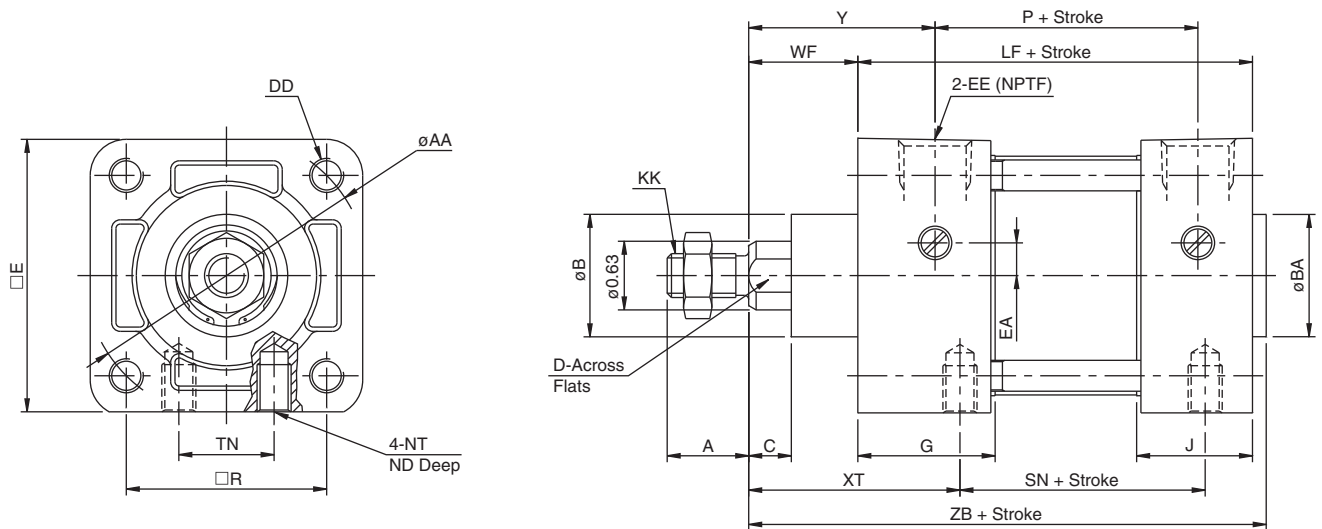

(in)

Bore (in)	KK	A	AA	B	BA	C	D	DD	E	EA	EE	G	J	ND	NT	R	WF	Y	LF	P	ZB	TN	XT	SN
150 (1.5")	7/16-20	3/4	2.02	1 1/8	1 1/8	3/8	0.551	1/4-28	2	0.3	3/8	1.26	1.1	9/32	1/4-20	1.43	1	1.71	3 5/8	2.36	4 3/4	5/8	1 15/16	2 1/4
200 (2")	7/16-20	3/4	2.6	1 1/8	1 1/8	3/8	0.551	5/16-24	2 1/2	0.3	3/8	1.26	1.06	7/16	5/16-18	1.84	1	1.71	3 5/8	2.4	4 3/4	7/8	1 15/16	2 1/4
250 (2.5")	7/16-20	3/4	3.1	1 1/8	1 1/8	3/8	0.551	5/16-24	3	0	3/8	1.3	1.06	19/32	3/8-16	2.19	1	1.75	3 3/4	2.48	4 7/8	1 1/4	1 15/16	2 3/8

Non-Rotating Rod – Foot Mounting Type NC A1KL

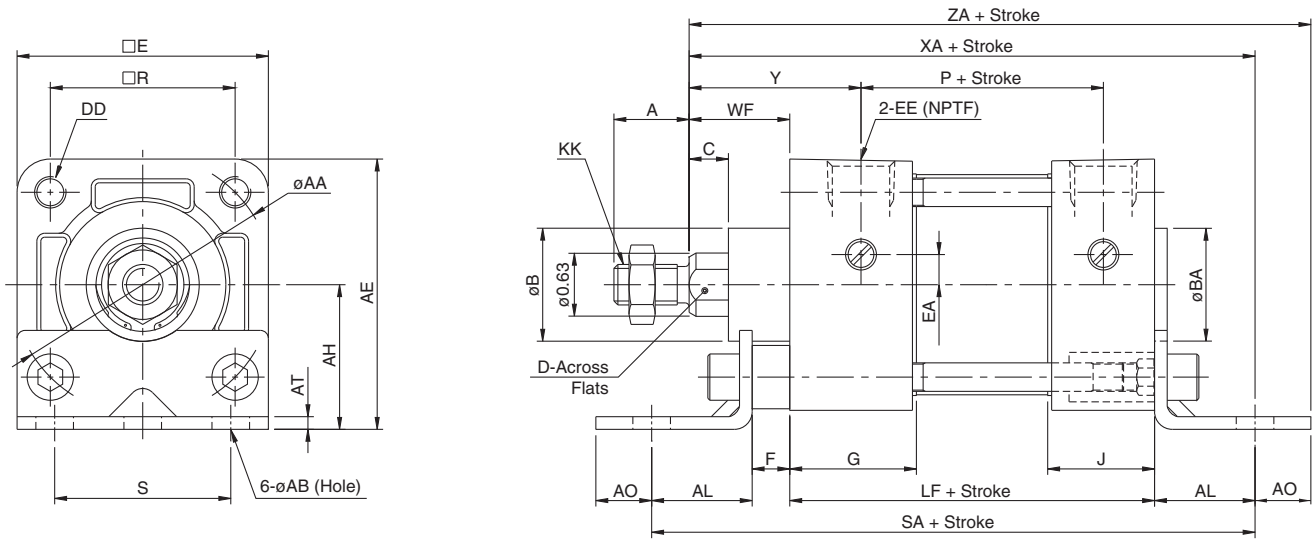

(in)

Bore (in)	KK	A	AA	AB	AE	AH	AL	AO	AT	B	BA	C	D	DD	E	EA	EE	F	J	R	S	WF	Y	P	LF	SA	XA	ZA
150 (1.5")	7/16-20	3/4	2.02	3/8	2 3/16	1 3/16	1	7/16	1/8	1 1/8	1 1/8	3/8	0.551	1/4-28	2	0.3	3/8	3/8	1.1	1.43	1 1/4	1	1.71	2.36	3 5/8	6	5 5/8	6.062
200 (2")	7/16-20	3/4	2.6	3/8	2 11/16	1 7/16	1	9/16	1/8	1 1/8	1 1/8	3/8	0.551	5/16-24	2.5	0.3	3/8	3/8	1.06	1.84	1 3/4	1	1.71	2.4	3 5/8	6	5 5/8	6.187
250 (2.5")	7/16-20	3/4	3.1	3/8	3 1/8	1 5/8	1	9/16	1/8	1 1/8	1 1/8	3/8	0.551	5/16-24	3	0	3/8	3/8	1.06	2.19	2 1/4	1	1.75	2.48	3 3/4	6 1/8	5 3/4	6.321

Non-Rotating Rod – Front Flange Mounting Type NC A1KF

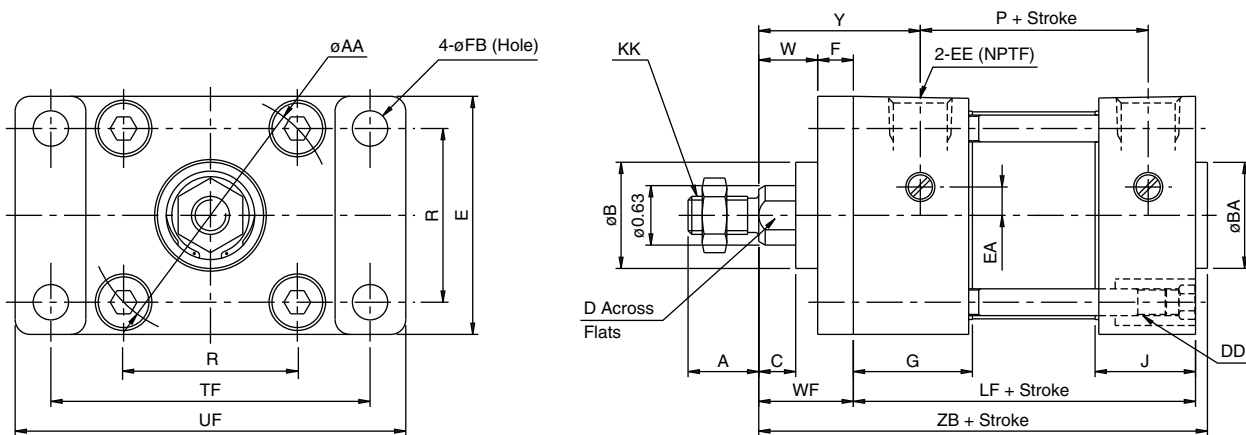

(in)

Bore (in)	KK	A	AA	B	BA	C	D	DD	E	EA	EE	F	FB	G	J	R	TF	UF	W	WF	Y	LF	P	ZB
150 (1.5")	7/16-20	3/4	2.02	1 1/8	1 1/8	3/8	0.551	1/4-28	2	0.3	3/8	3/8	5/16	1.26	1.1	1.43	2 3/4	3 3/8	5/8	1	1.71	3 5/8	2.36	4 3/4
200 (2")	7/16-20	3/4	2.6	1 1/8	1 1/8	3/8	0.551	5/16-24	2 1/2	0.3	3/8	3/8	3/8	1.26	1.06	1.84	3 3/8	4 1/8	5/8	1	1.71	3 5/8	2.4	4 3/4
250 (2.5")	7/16-20	3/4	3.1	1 1/8	1 1/8	3/8	0.551	5/16-24	3	0	3/8	3/8	3/8	1.3	1.06	2.19	3 7/8	4 5/8	5/8	1	1.75	3 3/4	2.48	4 7/8

Non-Rotating Rod – Rear Flange Mounting Type NC ■ A1KG

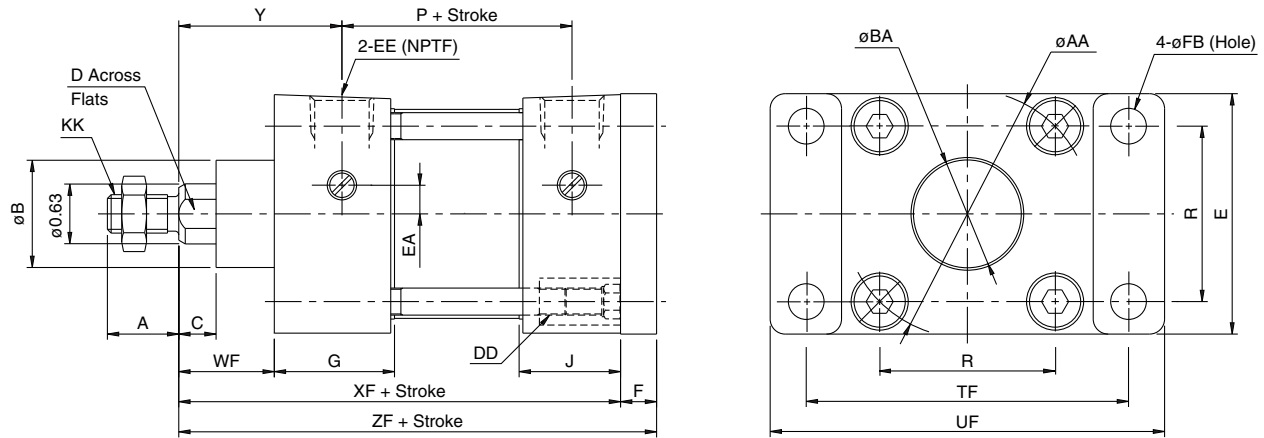

(in)

Bore (in)	KK	A	AA	B	BA	C	D	DD	E	EA	EE	F	FB	G	J	R	TF	UF	WF	Y	P	XF	ZF
150 (1.5")	7/16-20	3/4	2.02	1 1/8	1 1/8	3/8	0.551	1/4-28	2	0.3	3/8	3/8	5/16	1.26	1.1	1.43	2 3/4	3 3/8	1	1.71	2.36	4 5/8	5
200 (2")	7/16-20	3/4	2.6	1 1/8	1 1/8	3/8	0.551	5/16-24	2 1/2	0.3	3/8	3/8	3/8	1.26	1.06	1.84	3 3/8	4 1/8	1	1.71	2.4	4 5/8	5
250 (2.5")	7/16-20	3/4	3.1	1 1/8	1 1/8	3/8	0.551	5/16-24	3	0	3/8	3/8	3/8	1.3	1.06	2.19	3 7/8	4 5/8	1	1.75	2.48	4 3/4	5 1/8

Non-Rotating Rod – Double Detachable Rear Clevis Mounting Type NC ■ A1KD

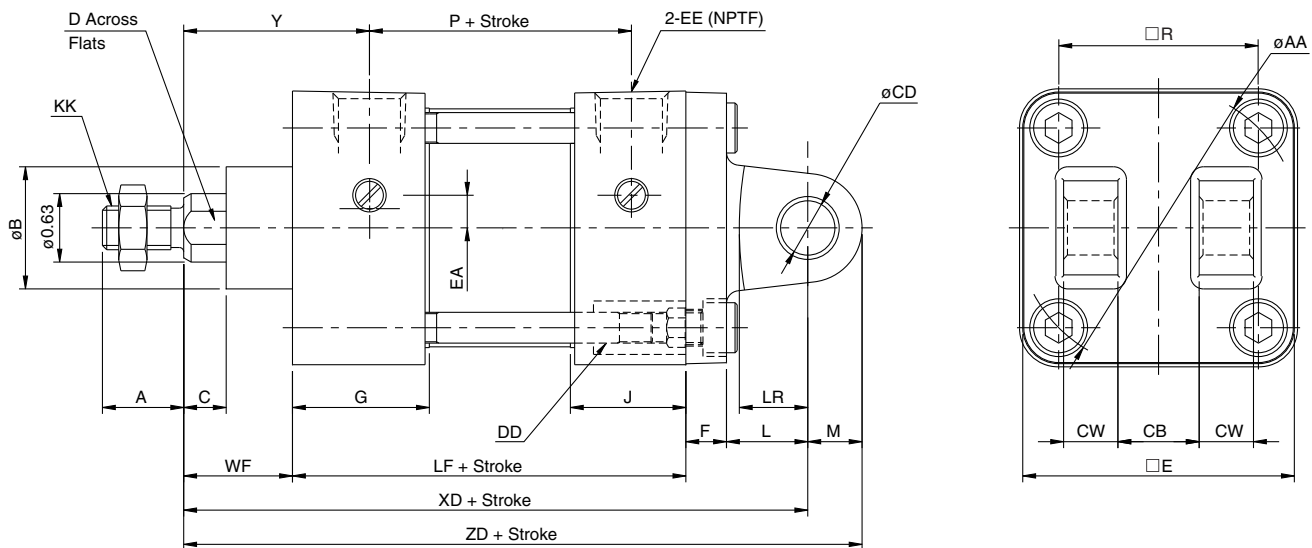

(in)

Bore (in)	KK	A	AA	B	C	CB	CD	CW	D	DD	E	EA	EE	F	G	J	L	LR	M	R	WF	XD	Y	LF	P	ZD
150 (1.5")	7/16-20	3/4	2.021	1 1/8	3/8	3/4	1/2	1/2	0.551	1/4-28	2	0.3	3/8	3/8	1.26	1.1	3/4	5/8	1/2	1.43	1	5 3/4	1.71	3 5/8	2.36	6 1/4
200 (2")	7/16-20	3/4	2.6	1 1/8	3/8	3/4	1/2	1/2	0.551	5/16-24	2 1/2	0.3	3/8	3/8	1.26	1.06	3/4	5/8	1/2	1.84	1	5 3/4	1.71	3 5/8	2.4	6 1/4
250 (2.5")	7/16-20	3/4	3.1	1 1/8	3/8	3/4	1/2	1/2	0.551	5/16-24	3	0	3/8	3/8	1.3	1.06	3/4	5/8	1/2	2.19	1	5 7/8	1.75	3 3/4	2.48	6 3/8

Non-Rotating Rod – Center Trunnion Mounting Type NC□A1KT

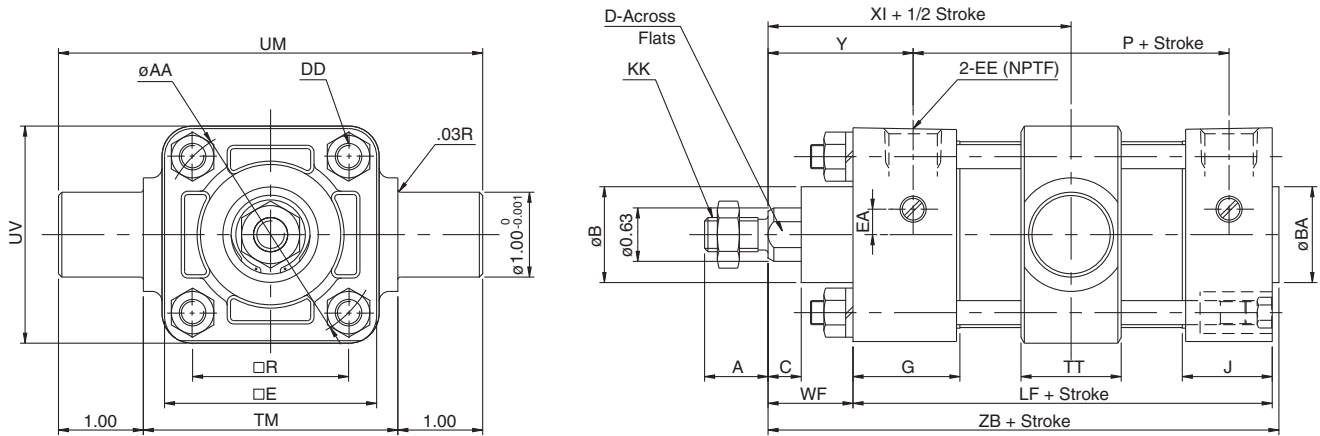

Bore (in)	KK	A	AA	B	BA	C	D	DD	E	EA	EE	G	J	R	TM	TT	UM	UV	WF	Y	P	LF	XI	ZB
150 (1.5")	7/16-20	3/4	2.02	1 1/8	1 1/8	3/8	0.551	1/4-28	2	0.3	3/8	1.26	1.1	1.43	2.5	1.18	4.5	2	1	1.71	2.36	3 5/8	2.89	4 3/4
200 (2")	7/16-20	3/4	2.6	1 1/8	1 1/8	3/8	0.551	5/16-24	2 1/2	0.3	3/8	1.26	1.06	1.84	3	1.18	5	2.56	1	1.71	2.4	3 5/8	2.91	4 3/4
250 (2.5")	7/16-20	3/4	3.1	1 1/8	1 1/8	3/8	0.551	5/16-24	3	0	3/8	1.3	1.06	2.19	3.5	1.18	5.5	3.39	1	1.75	2.48	3 3/4	2.99	4 7/8

Non-Rotating Rod – Single Detachable Rear Clevis Mounting Type NC□A1KC

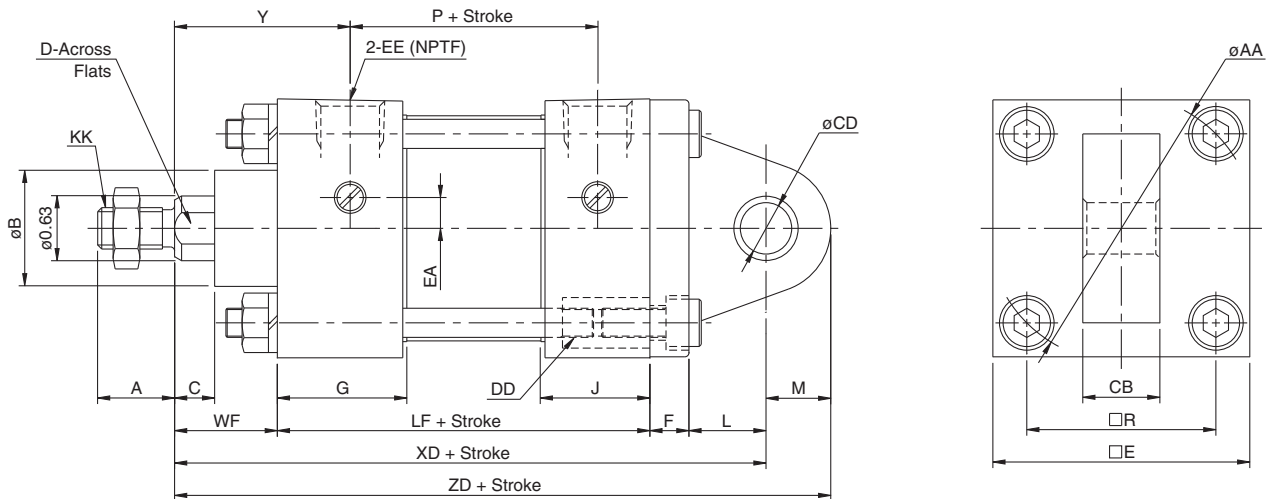

Bore (in)	KK	A	AA	B	C	CB	CD	D	DD	E	EA	EE	F	G	J	L	M	P	R	WF	Y	LF	XD	ZD
150 (1.5")	7/16-20	3/4	2.02	1 1/8	3/8	3/4	1/2	0.551	1/4-28	2	0.3	3/8	3/8	1.26	1.1	3/4	5/8	2.36	1.43	1	1.71	3 5/8	5 3/4	6 3/8
200 (2")	7/16-20	3/4	2.6	1 1/8	3/8	3/4	1/2	0.551	5/16-24	2 1/2	0.3	3/8	3/8	1.26	1.06	3/4	5/8	2.4	1.84	1	1.71	3 5/8	5 3/4	6 3/8
250 (2.5")	7/16-20	3/4	3.1	1 1/8	3/8	3/4	1/2	0.551	5/16-24	3	0	3/8	3/8	1.3	1.06	3/4	5/8	2.48	2.19	1	1.75	3 3/4	5 7/8	6 1/2

Non-Rotating Rod – Double Rear Clevis Mounting Type NC □A1KX

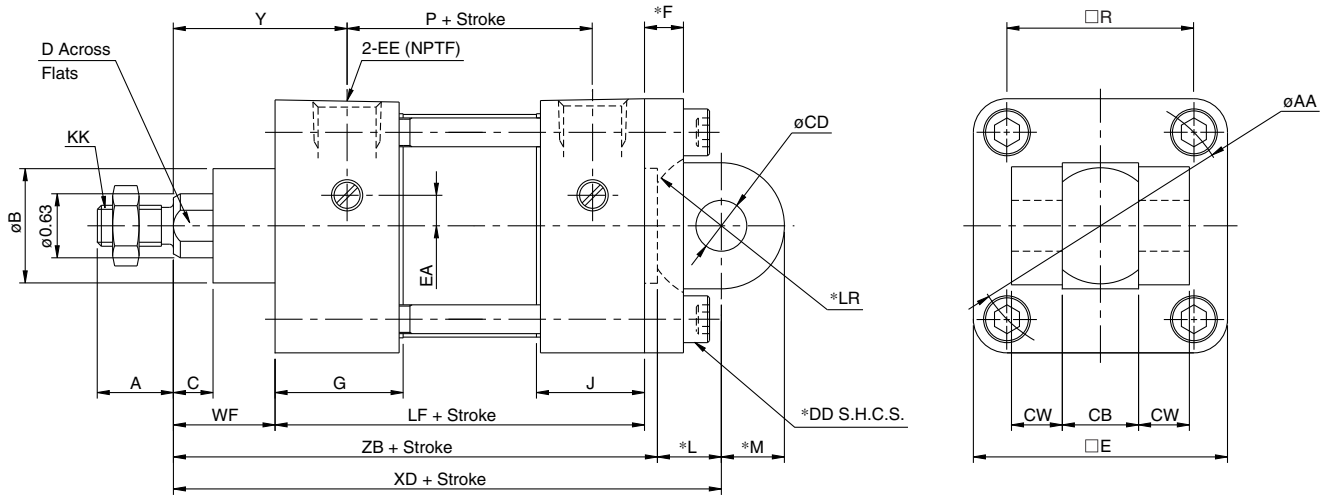

Bore (in)	KK	A	AA	B	C	CB	CD	CW	D	DD	E	EA	EE	F	G	J	L	LR	M	P	R	WF	LF	XD	ZB
150 (1.5")	7/16-20	3/4	2.02	1 1/8	3/8	3/4	1/2	1/2	0.551	1/4-28	2	0.3	3/8	3/8	1.26	1.1	5/8	3/4	5/8	2.36	1.43	1	3 5/8	5 3/8	4 3/4
200 (2")	7/16-20	3/4	2.6	1 1/8	3/8	3/4	1/2	1/2	0.551	5/16-24	2 1/2	0.3	3/8	3/8	1.26	1.06	5/8	3/4	5/8	2.4	1.84	1	3 5/8	5 3/8	4 3/4
250 (2.5")	7/16-20	3/4	3.1	1 1/8	3/8	3/4	1/2	1/2	0.551	5/16-24	3	0	3/8	3/8	1.3	1.06	5/8	3/4	5/8	2.48	2.19	1	3 3/4	5 1/2	4 7/8

Note: Mounting dimensions are the same as NFPA (MP1) except where marked (*).

Non-Rotating Rod – Side Lug Mounting Type NC □A1KS

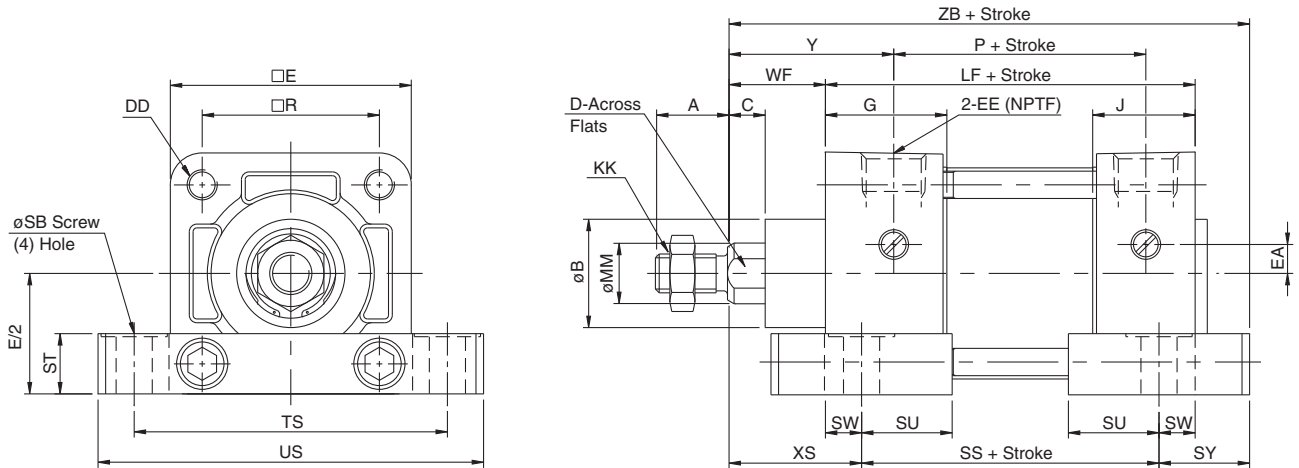

Bore (in)	MM	KK	A	B	C	D	DD	E	EA	EE	G	J	LF	P	R	SB	SS	ST	SU	SW	SY	TS	US	WF	XS	Y	ZB
150 (1.5")	5/8	7/16-20	3/4	1 1/8	3/8	0.551	1/4-28	2	0.3	3/8	1.26	1.1	3.63	2.36	1.43	3/8	2.88	5/8	0.94	3/8	0.94	2.75	3.50	1	1.38	1.71	5.19
200 (2")	5/8	7/16-20	3/4	1 1/8	3/8	0.551	5/16-24	2 1/2	0.3	3/8	1.26	1.06	3.63	2.4	1.84	3/8	2.88	5/8	0.94	3/8	0.94	3.25	4	1	1.38	1.71	5.19
250 (2.5")	5/8	7/16-20	3/4	1 1/8	3/8	0.551	5/16-24	3	0	3/8	1.3	1.06	3.75	2.48	2.19	3/8	3	3/4	0.94	3/8	0.94	3.75	4.50	1	1.38	1.75	5.31

(in)

Non-Rotating Rod – Head Trunnion Mounting Type NC A1KS

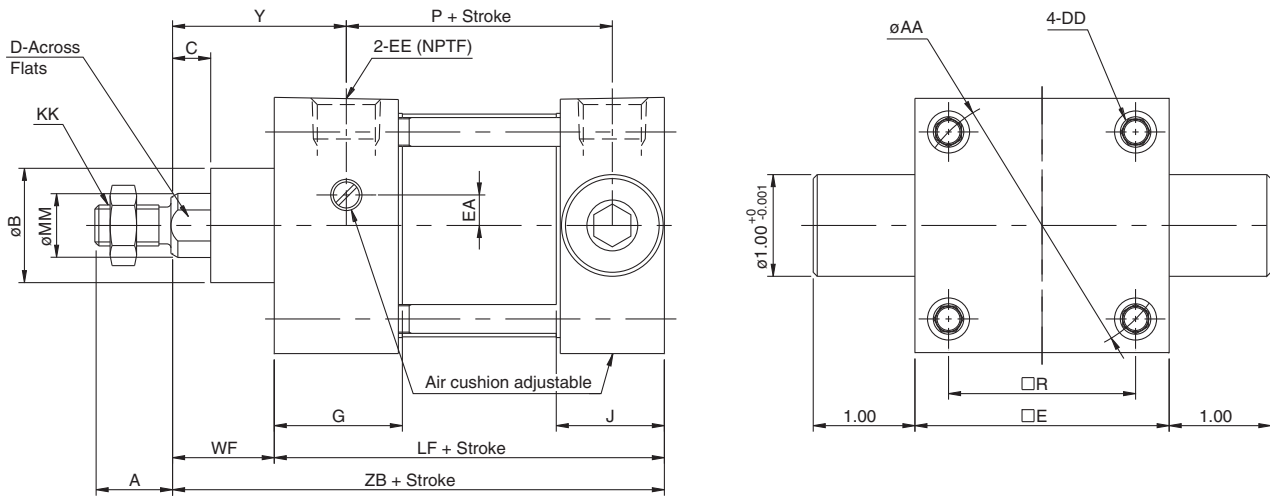

(in)

Bore (in)	MM	KK	A	AA	B	C	D	DD	E	EA	EE	G	J	R	WF	Y	LF	P	ZB
150 (1.5")	5/8	7/16-20	3/4	2.02	1 1/8	3/8	0.551	1/4-28	2	0.3	3/8	1.26	1.23	1.43	1	1.71	3.75	2.36	4.75
200 (2")	5/8	7/16-20	3/4	2.6	1 1/8	3/8	0.551	5/16-24	2 1/2	0.3	3/8	1.26	1.19	1.84	1	1.71	3.75	2.4	4.75
250 (2.5")	5/8	7/16-20	3/4	3.1	1 1/8	3/8	0.551	5/16-24	3	0	3/8	1.3	1.19	2.19	1	1.75	3.88	2.48	4.88

Double Rod Non-Rotating – Basic Mounting Type NC A1KWB

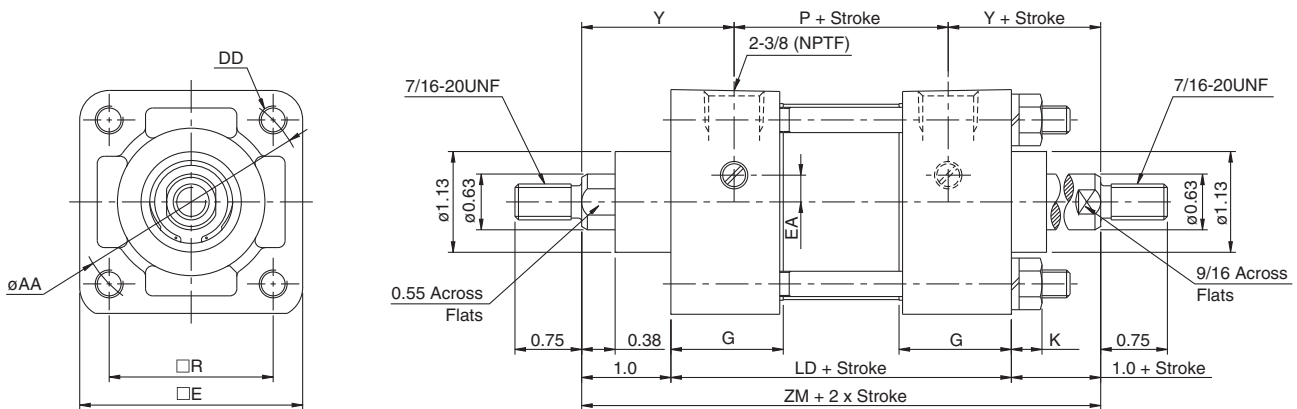

Bore (in)	AA	DD	E	EA	G	R	Y	LD	P	ZM	K
150 (1.5")	2.02	1/4-28	2	0.3	1.26	1.43	1.71	3.78	2.36	5.78	0.28
200 (2")	2.6	5/16-24	2 1/2	0.3	1.26	1.84	1.71	3.82	2.40	5.82	0.34
250 (2.5")	3.1	5/16-24	3	0	1.3	2.19	1.75	3.98	2.48	5.98	0.34

Double Rod Non-Rotating – Foot Mounting Type NC \square A1KWL

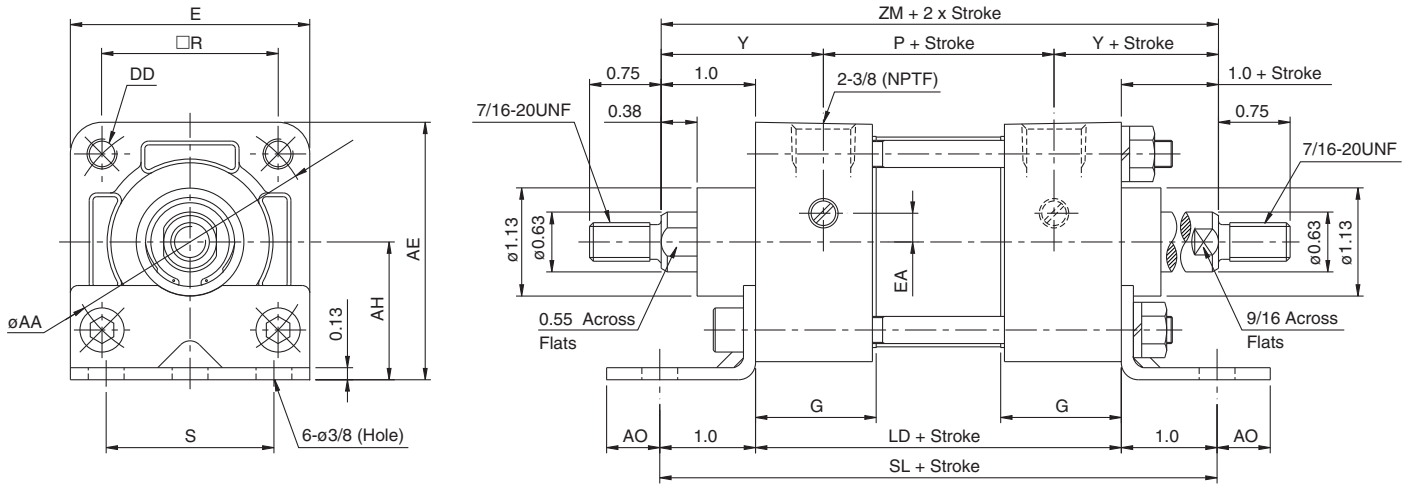

Bore (in)	AA	E	EA	G	AO	Y	LD	P	R	ZM	SL	S	AE	AH	DD
150 (1.5")	2.02	2	0.3	1.26	0.44	1.71	3.78	2.36	1.43	5.78	5.78	1.25	2.19	1.19	1/4-28
200 (2")	2.6	2 1/2	0.3	1.26	0.56	1.71	3.82	2.40	1.84	5.82	5.82	1.75	2.69	1.44	5/16-24
250 (2.5")	3.1	3	0	1.3	0.56	1.75	3.98	2.48	2.19	5.98	5.98	2.25	3.13	1.63	5/16-24

Double Rod Non-Rotating – Front Flange Mounting Type NC \square A1KWF

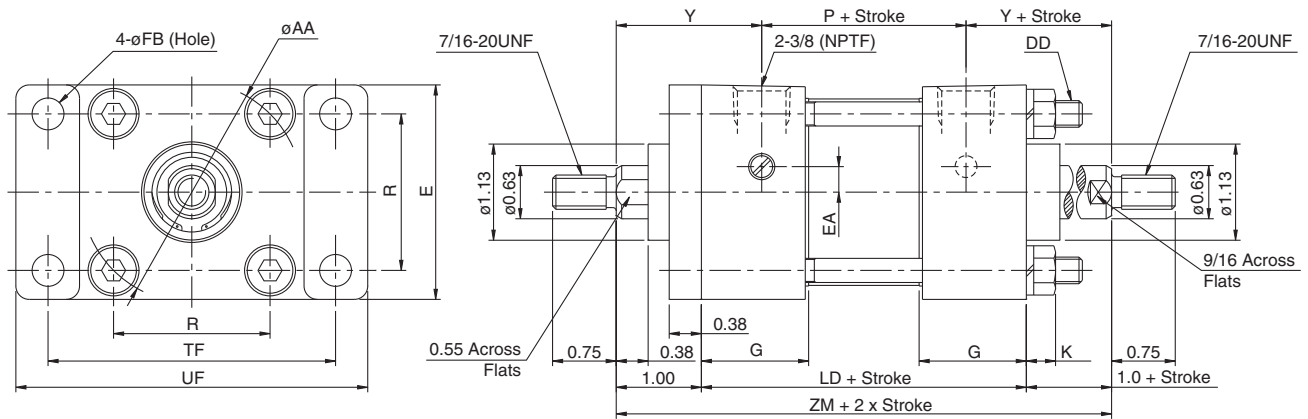

Bore (in)	AA	DD	E	EA	G	R	Y	LD	P	ZM	TF	UF	FB	K
150 (1.5")	2.02	1/4-28	2	0.3	1.26	1.43	1.71	3.78	2.36	5.78	2.75	3.38	0.31	0.28
200 (2")	2.6	5/16-24	2 1/2	0.3	1.26	1.84	1.71	3.82	2.40	5.82	3.38	4.13	0.38	0.34
250 (2.5")	3.1	5/16-24	3	0	1.3	2.19	1.75	3.98	2.48	5.98	3.88	4.63	0.38	0.34

Double Rod Non-Rotating – Side Tapped Mounting Type NC □A1KWR

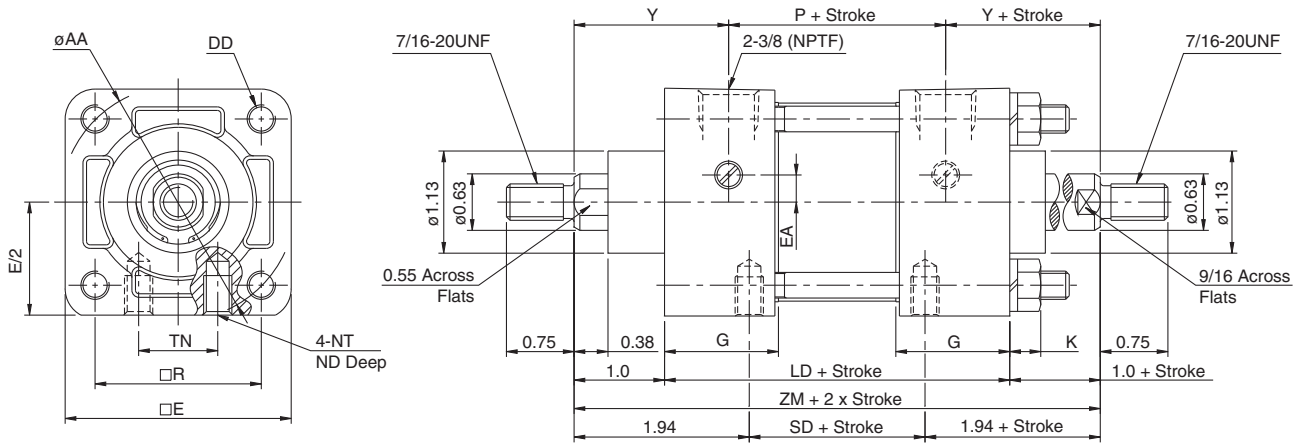

Bore (in)	AA	DD	E	EA	G	R	Y	LD	P	SD	ZM	K	TN	ND	NT
150 (1.5")	2.02	1/4-28	2	0.3	1.26	1.43	1.71	3.78	2.36	1.90	5.78	0.28	0.63	9/32	1/4-20
200 (2")	2.6	5/16-24	2 1/2	0.3	1.26	1.84	1.71	3.82	2.40	1.94	5.82	0.34	0.88	7/16	5/16-18
250 (2.5")	3.1	5/16-24	3	0	1.3	2.19	1.75	3.98	2.48	2.10	5.98	0.34	1.25	19/32	3/8-16

Double Rod Non-Rotating – Center Trunnion Mounting Type NC □A1KWT

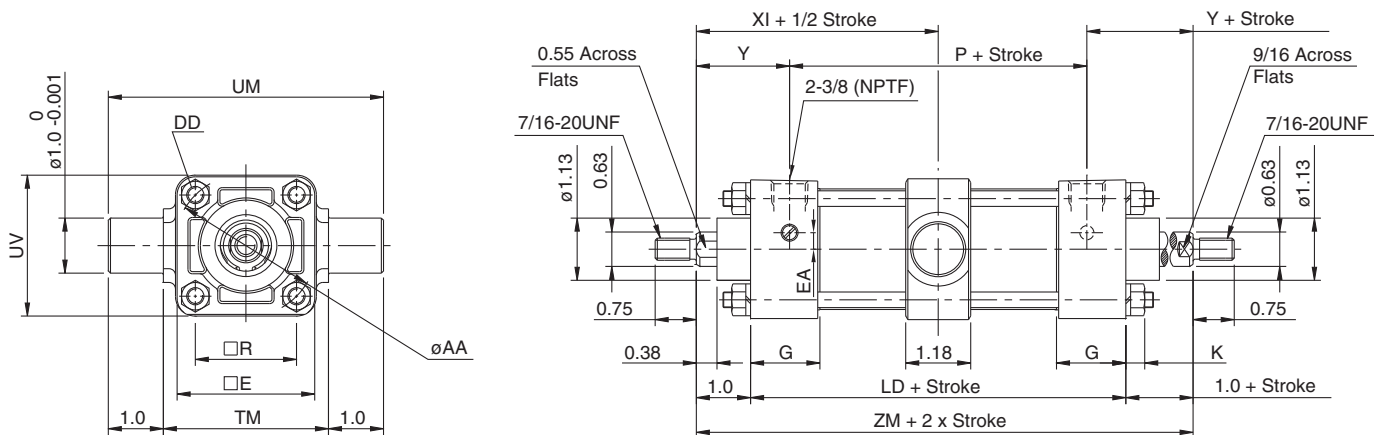

Bore (in)	AA	E	EA	G	R	Y	LD	P	ZM	UV	TM	K	UM	XI	DD
150 (1.5")	2.02	2	0.3	1.26	1.43	1.71	3.78	2.36	5.78	2.0	2.5	0.28	4.5	2.89	1/4-28
200 (2")	2.60	2 1/2	0.3	1.26	1.84	1.71	3.82	2.40	5.82	2.56	3	0.34	5	2.91	5/16-24
250 (2.5")	3.10	3	0	1.3	2.19	1.75	3.98	2.48	5.98	3.39	3.5	0.34	5.5	2.99	5/16-24

Medium Duty Air Cylinder

Series NCA1

Stainless Steel Rod (XC6)



- Stainless Steel piston rod is used to protect in harsh or wet environments.
- Auto-switch mounting available.

Specifications

Bore size (inch)	1.5	2	2.5	3.25	4
Media	Air				
Max. Operating Pressure	250 psi (17.5 kgf/cm ²)				
Min. Operating Pressure	8 psi (0.5 kgf/cm ²)				
Rod Material	SUS304				
Ambient and Media Temperature	40 to 140°F (5 to 60°C)				
Piston Speed	2 to 20 inch/sec (50 to 500mm/sec)				
Stroke Tolerance (mm)	to 10.0: ^{+1.0} ₀				
Cushion	Air Cushion Standard				
Mounting Types	Basic, Foot, Flange Side Tapped, Clevis, Head Trunnion Rod Trunnion, Center Trunnion, Side Lug				

Standard Stroke List

Bore size	Standard Stroke (in)
1.5"	1, 2, 3, 4, 5, 6, 8, 10, 12, 14, 16, 18, 20, 24
2", 2.5"	1, 2, 3, 4, 5, 6, 8, 10, 12, 14, 16, 18, 20, 24
3.25", 4"	1, 2, 3, 4, 5, 6, 8, 10, 12, 14, 16, 18, 20, 24, 28, 30

How To Order

NCDA1 MOUNTING BORE - STROKE SUFFIX - XC6

Ex: NCDA1B 150-0400-XC6

Auto-switch capable

Stainless Steel Rod

Low Speed (XB9)



- Smooth movements even at 0.4 to 2 inch/sec
- Auto switch mounting available.

Specifications

Bore size (inch)	1.5	2	2.5	3.25	4
Media	Air				
Max. Operating Pressure	250 psi (17.5 kgf/cm ²)				
Min. Operating Pressure	8 psi (0.5 kgf/cm ²)				
Ambient and Media Temperature	40 to 140°F (5 to 60°C)				
Piston Speed	0.4 to 2 inch/sec (10 to 50mm/sec)				
Cushion	None				
Mounting Types	Basic, Foot, Flange Side Tapped, Clevis, Head Trunnion Rod Trunnion, Center Trunnion, Side Lug				

Standard Stroke List

Bore size	Standard Stroke (in)
1.5"	1, 2, 3, 4, 5, 6, 8, 10, 12, 14, 16, 18, 20, 24
2", 2.5"	1, 2, 3, 4, 5, 6, 8, 10, 12, 14, 16, 18, 20, 24
3.25", 4"	1, 2, 3, 4, 5, 6, 8, 10, 12, 14, 16, 18, 20, 24, 28, 30

How To Order

NC D A1 MOUNTING BORE - STROKE N - XB9

Ex: NCDA1B 150-0400-XB9

Auto-switch capable

Low Speed

Standard

High Temperature (XB6)



• Use at high temperature up to 300°F.

Specifications

Bore size (inch)	1.5	2	2.5	3.25	4
Media	Air				
Max. Operating Pressure	250 psi (17.5 kgf/cm ²)				
Min. Operating Pressure	8 psi (0.5 kgf/cm ²)				
Ambient and Media Temperature	14 to 300°F (-10 to -150°C)				
Seal Material	Fluro Rubber				
Piston Speed	2 to 20 inch/sec (50 to 500mm/sec)				
Stroke Tolerance (mm)	to 10.0: ^{+1.0} ₀				
Cushion	Air Cushion Standard				
Mounting Types	Basic, Foot, Flange				
	Side Tapped, Clevis, Head Trunnion Rod Trunnion, Center Trunnion, Side Lug				

Standard Stroke List

Bore size	Standard Stroke (in)
1.5"	1, 2, 3, 4, 5, 6, 8, 10, 12, 14, 16, 18, 20, 24
2", 2.5"	1, 2, 3, 4, 5, 6, 8, 10, 12, 14, 16, 18, 20, 24
3.25", 4"	1, 2, 3, 4, 5, 6, 8, 10, 12, 14, 16, 18, 20, 24, 28, 30

How To Order

NCA1 MOUNTING BORE - STROKE SUFFIX - XB6

Ex: NCA1B 150-0400-XB6

Auto-switch capable not available

High Temperature

Low Temperature (XB7)



• Use at low temperature down to -22°F.

Specifications

Bore size (inch)	1.5	2	2.5	3.25	4
Media	Air				
Max. Operating Pressure	250 psi 17.5 kgf/cm ²)				
Min. Operating Pressure	8 psi (0.5 kgf/cm ²)				
Ambient and Media Temperature	-22 to 140°F (-30 to 60°C)				
Seal Material	Low Durometer Nitril Rubber				
Piston Speed	2 to 20 inch/sec (10 to 50mm/sec)				
Cushion	None				
Mounting Types	Basic, Foot, Flange, Center Trunnion, Side Tapped, Clevis, Side Lug Rod and Head Trnion				

Standard Stroke List

Bore size	Standard Stroke (in)
1.5"	1, 2, 3, 4, 5, 6, 8, 10, 12, 14, 16, 18, 20, 24
2", 2.5"	1, 2, 3, 4, 5, 6, 8, 10, 12, 14, 16, 18, 20, 24
3.25", 4"	1, 2, 3, 4, 5, 6, 8, 10, 12, 14, 16, 18, 20, 24, 28, 30

How To Order

NCA1 MOUNTING BORE - STROKE N - XB7

Ex: NCA1B 150-0400-XB7

Auto-switch capable not available

Low Temperature

Standard

Special Trunnion Location (X46US)



Specifications

Bore size (inch)	1.5	2	2.5	3.25	4
Media	Air				
Max. Operating Pressure	250 psi (1.75 kgf/cm ²)				
Min. Operating Pressure	8 psi (0.05 kgf/cm ²)				
Ambient and Media Temperature	40 to 140°F (5 to 60°C)				
Seal Material	Nitrile Rubber				
Piston Speed	2 to 20 inch/sec (50 to 500mm/sec)				
Cushion	Air Cushion Standard				
Mounting Type	Center Trunnion				

Standard Stroke List

Bore size	Standard Stroke (in)
1.5"	1, 2, 3, 4, 5, 6, 8, 10, 12, 14, 16, 18, 20, 24
2", 2.5"	1, 2, 3, 4, 5, 6, 8, 10, 12, 14, 16, 18, 20, 24
3.25", 4"	1, 2, 3, 4, 5, 6, 8, 10, 12, 14, 16, 18, 20, 24, 28, 30

How To Order

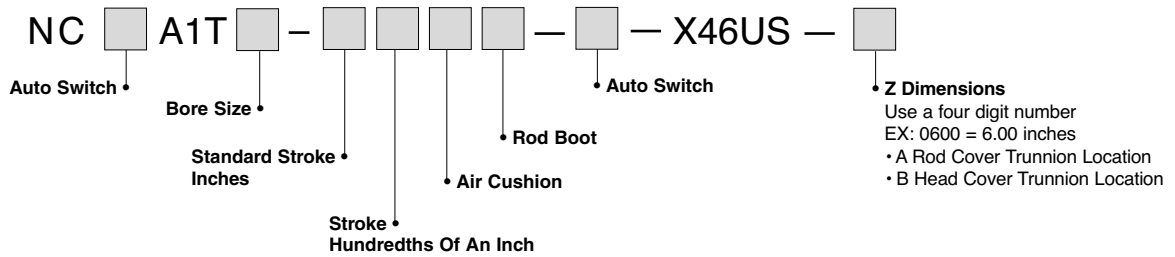

Special Rod Trunnion Location NC A1T (150 to 400) - **** - X46US - ****

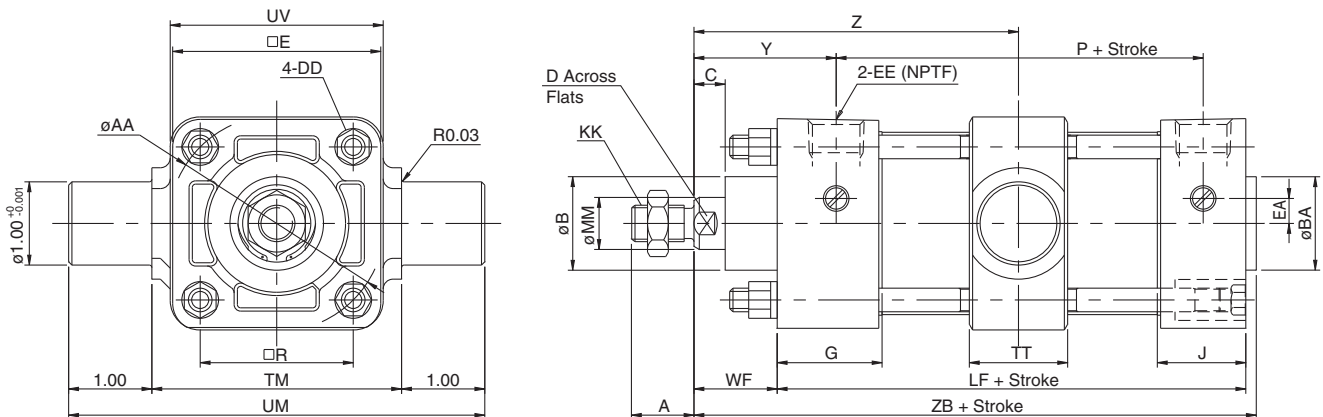

Bore (in)	MM	KK	A	AA	B	BA	C	D	DD	E	EA	EE	G	J	R	TM	TT	UM	UV	WF	Y	P	LF	ZB	Z RANGE Min. Max.
150 (1.5")	5/8	7/16-20	3/4	2.02	1 1/8	1 1/8	3/8	9/16	1/4-28	2	0.3	3/8	1.26	1.1	1.43	2.5	1.18	4.5	2	1	1.71	2.36	3 5/8	4 3/4	2.87 2.89 + Stroke
200 (2")	5/8	7/16-20	3/4	2.6	1 1/8	1 1/8	3/8	9/16	5/16-24	2 1/2	0.3	3/8	1.26	1.06	1.84	3	1.18	5	2.56	1	1.71	2.4	3 5/8	4 3/4	2.87 2.91 + Stroke
250 (2.5")	5/8	7/16-20	3/4	3.1	1 1/8	1 1/8	3/8	9/16	5/16-24	3	0	3/8	1.3	1.06	2.19	3.5	1.18	5.5	3.39	1	1.75	2.48	3 3/4	4 7/8	2.91 2.99 + Stroke
325 (3.25")	1	3/4-16	1 1/8	3.9	1 1/2	1 1/2	1/2	7/8	3/8-24	3 3/4	0	1/2	1.57	1.18	2.76	4.5	1.34	6.5	4.33	1 3/8	2.34	2.72	4 1/4	5 53/64	3.63 2.91 + Stroke
400 (4")	1	3/4-16	1 1/8	4.7	1 1/2	1 1/2	1/2	7/8	3/8-24	4 1/2	0	1/2	1.57	1.18	3.32	5.25	1.57	7.25	5.12	1 3/8	2.34	2.72	4 1/4	5 53/64	3.75 2.95 + Stroke

Special Rod Trunnion Location NC A1T (150 to 400) - **** - X46US - A

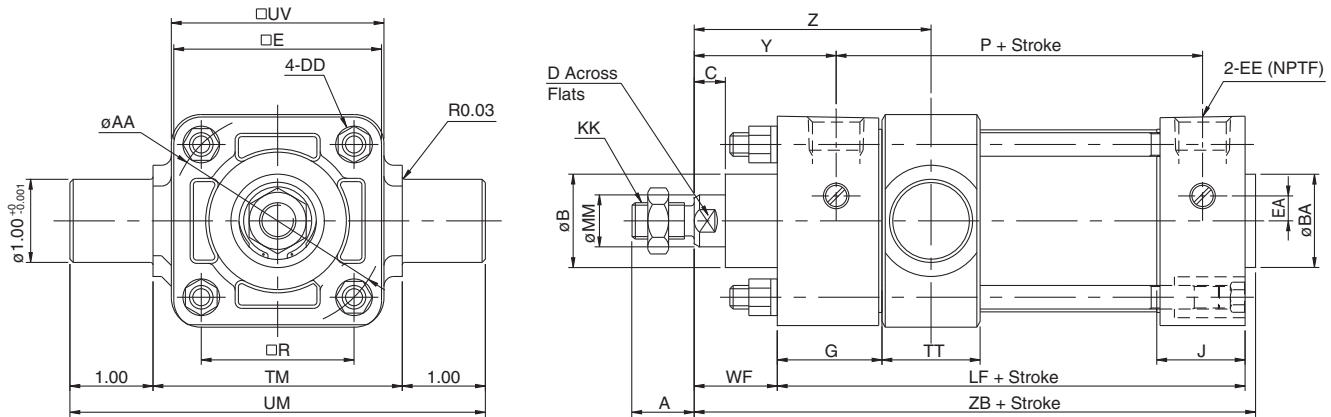

(in)

Bore (in)	MM	KK	A	AA	B	BA	C	D	DD	E	EA	EE	G	J	R	TM	TT	UM	UV	WF	Y	P	LF	Z	ZB
150 (1.5")	5/8	7/16-20	3/4	2.02	1 1/8	1 1/8	3/8	9/16	1/4-28	2	0.3	3/8	1.26	1.1	1.43	2.5	1.18	4.5	2	1	1.71	2.36	3 5/8	2.81	4 3/4
200 (2")	5/8	7/16-20	3/4	2.6	1 1/8	1 1/8	3/8	9/16	5/16-24	2 1/2	0.3	3/8	1.26	1.06	1.84	3	1.18	5	2.56	1	1.71	2.4	3 5/8	2.81	4 3/4
250 (2.5")	5/8	7/16-20	3/4	3.1	1 1/8	1 1/8	3/8	9/16	5/16-24	3	0	3/8	1.3	1.06	2.19	3.5	1.18	5.5	3.39	1	1.75	2.48	3 3/4	2.85	4 7/8
325 (3.25")	1	3/4-16	1 1/8	3.9	1 1/2	1 1/2	1/2	7/8	3/8-24	3 3/4	0	1/2	1.57	1.18	2.76	4.5	1.34	6.5	4.33	1 3/8	2.34	2.72	4 1/4	3.58	5 53/64
400 (4")	1	3/4-16	1 1/8	4.7	1 1/2	1 1/2	1/2	7/8	3/8-24	4 1/2	0	1/2	1.57	1.18	3.32	5.25	1.57	7.25	5.12	1 3/8	2.34	2.72	4 1/4	3.70	5 53/64

Special Head Side Trunnion Location NC A1T (150 to 400) - **** - X46US - B

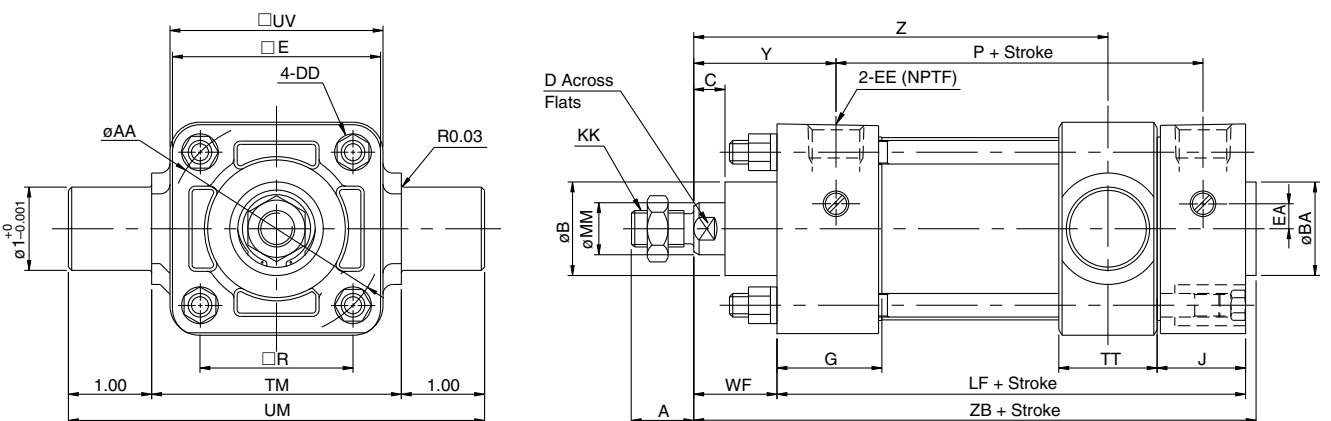

(in)

Bore (in)	MM	KK	A	AA	B	BA	C	D	DD	E	EA	EE	G	J	R	TM	TT	UM	UV	WF	Y	P	LF	ZB	Z
150 (1.5")	5/8	7/16-20	3/4	2.02	1 1/8	1 1/8	3/8	9/16	1/4-28	2	0.3	3/8	1.26	1.1	1.43	2.5	1.18	4.5	2	1	1.71	2.36	3 5/8	4 3/4	2.97 + Stroke
200 (2")	5/8	7/16-20	3/4	2.6	1 1/8	1 1/8	3/8	9/16	5/16-24	2 1/2	0.3	3/8	1.26	1.06	1.84	3	1.18	5	2.56	1	1.71	2.4	3 5/8	4 3/4	3.01 + Stroke
250 (2.5")	5/8	7/16-20	3/4	3.1	1 1/8	1 1/8	3/8	9/16	5/16-24	3	0	3/8	1.3	1.06	2.19	3.5	1.18	5.5	3.39	1	1.75	2.48	3 3/4	4 7/8	3.14 + Stroke
325 (3.25")	1	3/4-16	1 1/8	3.9	1 1/2	1 1/2	1/2	7/8	3/8-24	3 3/4	0	1/2	1.57	1.18	2.76	4.5	1.34	6.5	4.33	1 3/8	2.34	2.72	4 1/4	5 53/64	3.81 + Stroke
400 (4")	1	3/4-16	1 1/8	4.7	1 1/2	1 1/2	1/2	7/8	3/8-24	4 1/2	0	1/2	1.57	1.18	3.32	5.25	1.57	7.25	5.12	1 3/8	2.34	2.72	4 1/4	5 53/64	3.70 + Stroke

Oversized Rod with Special Trunnion Location (XB5 - X46US)



Standard Stroke List

Bore Size	Standard Stroke
2", 2.5"	1, 2, 3, 4, 5, 6, 8, 10, 12, 14, 16, 18, 20, 24
3.25", 4"	1, 2, 3, 4, 5, 6, 8, 10, 12, 14, 16, 18, 20, 24, 28, 30

How To Order

NC **D** **A1** **T** **BORE** - **STROKE** **XB5** - **X46US** - **Z**

Ex: NCDA1T 250-0400-XB5-X46US-0700

Auto-switch capable Oversized Rod Z Dimension

Z-Dimension use a four digit number

Special Trunnion Location NC **A1**T (200 to 400) - **** - XB5 - X46US - ****

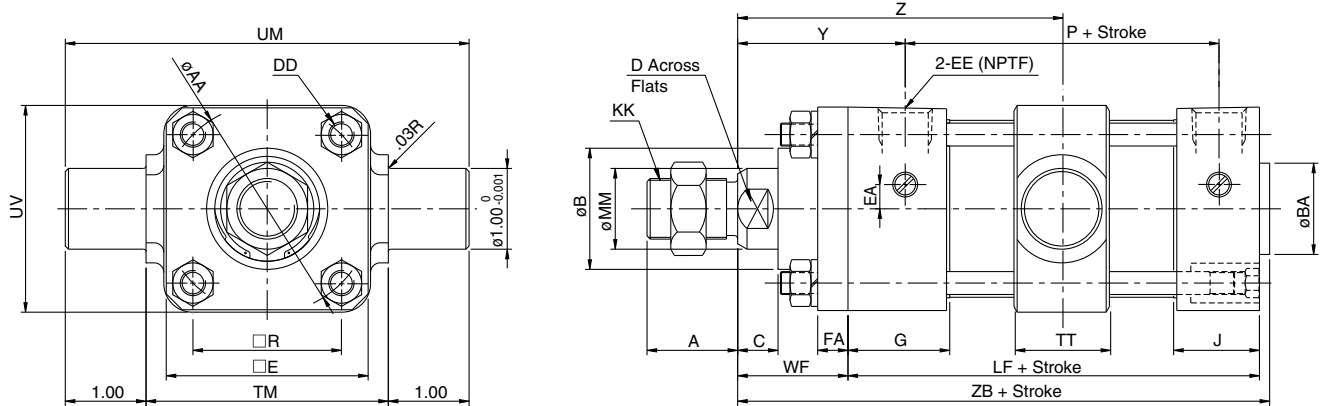

Bore (in)	MM	KK	A	AA	B	BA	C	D	DD	E	EA	EE	FA	G	J	R	TM	TT	UM	UV	WF	Y	LF	P	ZB	Z RANGE	
																										Min.	Max.
200 (2")	1	3/4-16	1 1/8	2.6	1 1/2	1 1/8	1/2	7/8	5/16-24	2 1/2	0.3	3/8	3/8	1.26	1.06	1.84	3	1.18	5	2.56	1 3/8	2.09	3 5/8	2.4	5 1/8	3.25	3.29 + Stroke
250 (2.5")	1	3/4-16	1 1/8	3.1	1 1/2	1 1/8	1/2	7/8	5/16-24	3	0	3/8	3/8	1.3	1.06	2.19	3.5	1.18	5.5	3.39	1 3/8	2.13	3 3/4	2.48	5 1/4	3.28	3.37 + Stroke
325 (3.25")	1 3/8	1-14	1 5/8	3.9	2	1 1/2	5/8	1 1/4	3/8-24	3 3/4	0	1/2	5/8	1.57	1.18	2.76	4.5	1.34	6.5	4.33	1 5/8	2.59	4 1/4	2.72	6 5/64	3.89	3.56 + Stroke
400 (4")	1 3/8	1-14	1 5/8	4.7	2	1 1/2	5/8	1 1/4	3/8-24	4 1/2	0	1/2	5/8	1.57	1.18	3.32	5.25	1.57	7.25	5.12	1 5/8	2.59	4 1/4	2.72	6 5/64	4.01	3.59 + Stroke

Stainless Steel Tie Rods / Tie Rod Nuts (X130US)



Specifications

Bore size (inch)	1.5	2	2.5	3.25	4
Media	Air				
Max. Operating Pressure	250 psi (17.5 kgf/cm ²)				
Min. Operating Pressure	8 psi (0.5 kgf/cm ²)				
Ambient and Media Temperature	40 to 140°F (5 to 60°C)				
Seal Material	Nitrile Rubber				
Piston Speed	2 to 20 inch/sec (50 to 500mm/sec)				
Stroke Tolerance	to 10.0: ±1.0				
Cushion	Air Cushion Both Ends				
Mounting Types	Basic, Foot, Flange, Center Trunnion, Side Tapped, Clevis, Rod Trunnion, Head Trunnion, Center Trunnion, Side Lug				

- Stainless steel piston rod is used to protect in harsh or wet environments
- Auto-switch mounting available

Standard Stroke List

Bore Size	Standard Stroke (in)
1.5"	1, 2, 3, 4, 5, 6, 8, 10, 12, 14, 16, 18, 20, 24
2", 2.5"	1, 2, 3, 4, 5, 6, 8, 10, 12, 14, 16, 18, 20, 24
3.25", 4"	1, 2, 3, 4, 5, 6, 8, 10, 12, 14, 16, 18, 20, 24, 28, 30

How To Order

NCDA1 MOUNTING BORE - STROKE SUFFIX - X130US

Ex: NCDA1B 150-0100-X130US

Stainless Steel Piston Rod, Tie Rods, Tie Rod Nuts, and Cushion Valve Needle

Basic Mounting Type NC A1B (MXO Mounting Style) - X130US

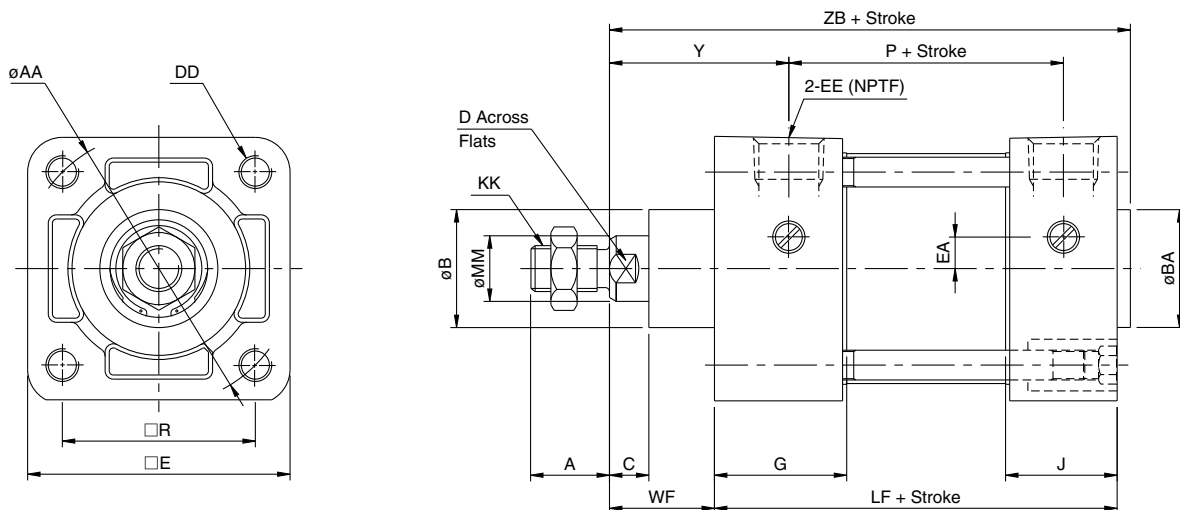

(in)

Bore (in)	MM	KK	A	AA	B	BA	C	D	DD	E	EA	EE	G	J	R	WF	Y	P	LF	ZB
150 (1.5")	5/8	7/16-20	3/4	2.02	1 1/8	1 1/8	3/8	9/16	1/4-28	2	0.3	3/8	1.26	1.1	1.43	1	1.71	2.36	3 5/8	4 3/4
200 (2")	5/8	7/16-20	3/4	2.6	1 1/8	1 1/8	3/8	9/16	5/16-24	2 1/2	0.3	3/8	1.26	1.06	1.84	1	1.71	2.4	3 5/8	4 3/4
250 (2.5")	5/8	7/16-20	3/4	3.1	1 1/8	1 1/8	3/8	9/16	5/16-24	3	0	3/8	1.3	1.06	2.19	1	1.75	2.48	3 3/4	4 7/8
325 (3.25")	1	3/4-16	1 1/8	3.9	1 1/2	1 1/2	1/2	7/8	3/8-24	3 3/4	0	1/2	1.57	1.18	2.76	1 3/8	2.34	2.72	4 1/4	5 53/64
400 (4")	1	3/4-16	1 1/8	4.7	1 1/2	1 1/2	1/2	7/8	3/8-24	4 1/2	0	1/2	1.57	1.18	3.32	1 3/8	2.34	2.72	4 1/4	5 53/64

Rod Boot



Rod boots are used to protect the surface of a piston rod in harsh environments.

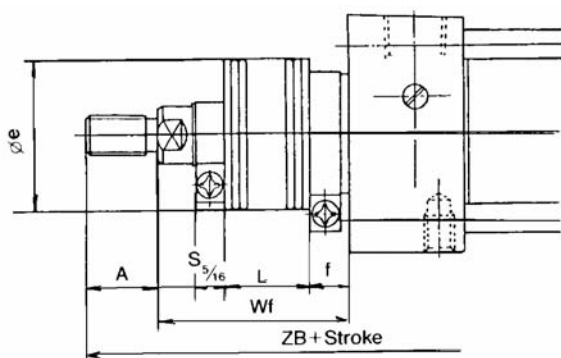

Boot Material

Suffix Code	Material	Max. Temperature
J	Nylon	140°F (60°C)
K	Neoprene	230°F (110°C)*

*Maximum temperature is for boot only.

How To Order

NCA1 MOUNTING BORE — STROKE CUSHION BOOT

Ex: NCDA1B150-0200J

Auto-switch capable

Rod Boot
J-Nylon Rod Boot
K-Neoprene Rod Boot

Rod Boot Dimensions

(in)

Bore	A	ϕe	f	L												
				0 to 2	2.1 to 4	4.1 to 6	6.1 to 8	8.1 to 10	10.1 to 12	12.1 to 14	14.1 to 16	16.1 to 20	20.1 to 24	24.1 to 28		
150 (1.5")	0.75	1.375	0.734													
200 (2")	0.75	1.375	0.734												6	—
250 (2.5")	0.75	1.375	0.734	0.5	1	1.5	2	2.5	3	3.5	4	5		6	—	
325 (2.25")	1.125	1.968	0.984											6	7	
400 (4")	1.125	1.968	0.984											6	7	

(in)

Bore	Wf										
	0 to 2	2.1 to 4	4.1 to 6	6.1 to 8	8.1 to 10	10.1 to 12	12.1 to 14	14.1 to 16	16.1 to 20	20.1 to 24	24.1 to 28
150 (1.5")	1.937	2.437	2.937	3.437	3.937	4.437	4.937	5.437	6.437	—	—
200 (2")	1.937	2.437	2.937	3.437	3.937	4.437	4.937	5.437	6.437	7.437	—
250 (2.5")	1.937	2.437	2.937	3.437	3.937	4.437	4.937	5.437	6.437	7.437	—
325 (2.25")	2.312	2.812	3.312	3.812	4.312	4.812	5.312	5.812	6.812	7.812	8.812
400 (4")	2.312	2.812	3.312	3.812	4.312	4.812	5.312	5.812	6.812	7.812	8.812

(in)

Bore	ZB										
	0 to 2	2.1 to 4	4.1 to 6	6.1 to 8	8.1 to 10	10.1 to 12	12.1 to 14	14.1 to 16	16.1 to 20	20.1 to 24	24.1 to 28
150 (1.5")	5.687	6.187	6.687	7.187	7.687	8.187	8.687	9.187	10.187	—	—
200 (2")	5.687	6.187	6.687	7.187	7.687	8.187	8.687	9.187	10.187	11.187	—
250 (2.5")	5.812	6.312	6.812	7.312	7.812	8.312	8.812	9.937	10.312	11.312	—
325 (2.25")	6.765	7.265	7.765	8.265	8.765	9.265	9.765	10.265	11.265	12.265	13.265
400 (4")	6.765	7.265	7.765	8.265	8.765	9.265	9.765	10.265	11.265	12.265	13.265

Oversized Rod / Standard Rod and Non-Rotating (XB5 / X119US)



Specifications

Bore size (inch)	2	2.5	3.25	4
Media	Air			
Max. Operating Pressure	250 psi (17.5 kgf/cm ²)			
Min. Operating Pressure	8 psi (0.5 kgf/cm ²)			
Ambient and Media Temperature	40 to 140°F (5 to -60°C)			
Piston Speed	2 to 20 inch/sec (50 to 500mm/sec)			
Cushion	Air Cushion Standard			
Mounting Types	Basic, Foot, Flange, Center Trunnion, Side Tapped, Side Lug			

Specifications for X119US

Max. Operating Pressure	150 psi
Min. Operating Pressure	15 psi
Operating Temperature Range	40 to 140°F (5 to -60°C)
Piston Speed Range	2 to 20 inch/sec (50 to 500mm/sec)
Cushion	Air Standard-Both ends
Mounting	See "How to Order"
Max. Rotating Torque	6.9lb - in (2.00" & 2.50" bore) 8.2lb - in (3.25" & 4.00" bore)
Non-rotating Rod Accuracy	±0.5" (2.00" & 2.50" bore) ±0.3 (3.25 & 4.00" bore)
Additional Feature	Oversized Piston Rod (XB5)

How To Order Oversized Rod / Standard

NCA1 [MOUNTING] [BORE] - [STROKE] - XB5

Ex: NCDA1B 250-0200-XB5

Auto-switch capable Oversized / Standard Rod

How To Order Oversized Rod/Non-Rotating

NCA1 K [MOUNTING] [BORE] - [STROKE] - X119US

Ex: NCDA1KB 200-0100-X119US

Auto-switch capable Oversized / Non-Rotating Rod

Standard Stroke List

Bore Size	Standard Stroke
2", 2.5"	1, 2, 3, 4, 5, 6, 8, 10, 12, 14, 16, 18, 20, 24
3.25", 4"	1, 2, 3, 4, 5, 6, 8, 10, 12, 14, 16, 18, 20, 24, 28, 30

Oversized Rod - Basic Type NC [] A1B (XB5)

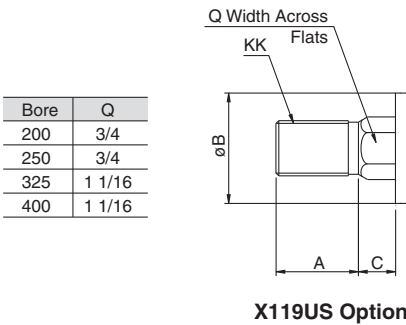

Bore	Q
200	3/4
250	3/4
325	1 1/16
400	1 1/16

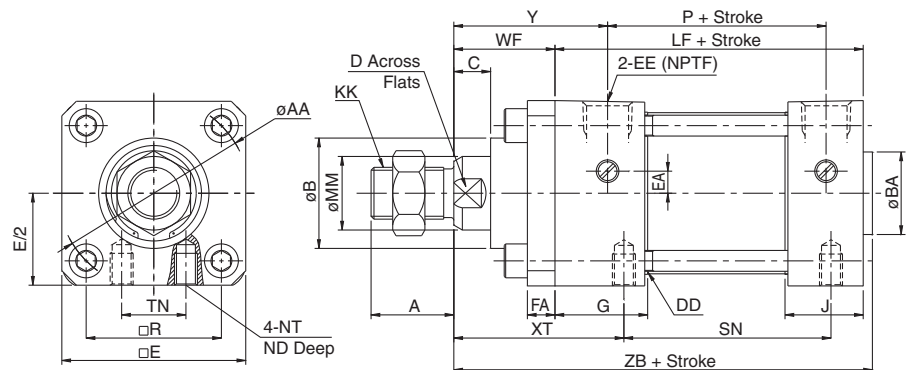

Bore (in)	MM	KK	A	AA	B	BA	C	D	DD	E	EA	EE	FA	G	J	R	ND	NT	TN	WF	XT	Y	LF	P	SN	ZB
200 (2")	1	3/4-16	1 1/8	2.6	1.5	1 1/8	1/2	7/8	5/16-24	2 1/2	0.3	3/8	3/8	1.26	1.06	1.84	7/16	5/16-18	0.875	1 3/8	2 5/16	2.09	3 5/8	2.40	2 1/4	5 1/8
250 (2.5")	1	3/4-16	1 1/8	3.1	1.5	1 1/8	1/2	7/8	5/16-24	3	0	3/8	3/8	1.30	1.06	2.19	19/32	3/8-16	1.25	1 3/8	2 5/16	2.13	3 3/4	2.48	2 3/8	5 1/4
325 (3.25")	1 3/8	1-14	1 5/8	3.9	2	1 1/2	5/8	1 1/4	3/8-24	3 3/4	0	1/2	5/8	1.57	1.18	2.76	5/8	1/2-13	1.5	1 5/8	2 11/16	2.59	4 1/4	2.72	2 5/8	6 5/64
400 (4")	1 3/8	1-14	1 5/8	4.7	2	1 1/2	5/8	1 1/4	3/8-24	4 1/2	0	1/2	5/8	1.57	1.18	3.32	5/8	1/2-13	2.06	1 5/8	2 11/16	2.59	4 1/4	2.72	2 5/8	6 5/64

Oversized Rod – Foot Mounting Type NC A1L (XB5)

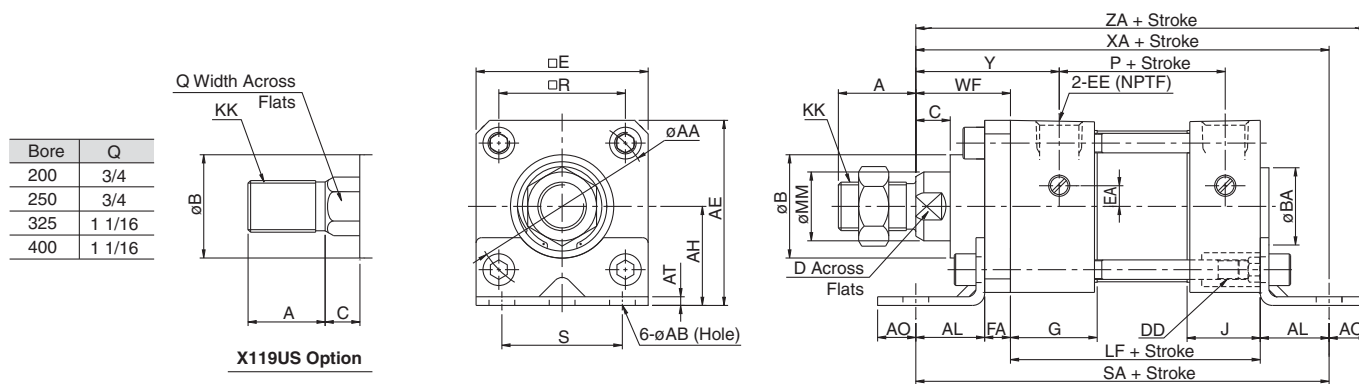

Bore (in)	MM	KK	A	AA	AB	AE	AH	AL	AO	AT	B	BA	C	D	DD	E	EA	EE	FA	G	J	R	S	WF	Y	P	LF	SA	XA	ZA
200 (2")	1	3/4-16	1 1/8	2.6	3/8	2 11/16	1 7/16	1	9/16	1/8	1.5	1 1/8	1/2	7/8	5/16-24	2 1/2	0.3	3/8	3/8	1.26	1.06	1.84	1 3/4	1 3/8	2.09	2.40	3 5/8	6	6	6 9/16
250 (2.5")	1	3/4-16	1 1/8	3.1	3/8	3 1/8	1 5/8	1	9/16	1/8	1.5	1 1/8	1/2	7/8	5/16-24	3	0	3/8	3/8	1.30	1.06	2.19	2 1/4	1 3/8	2.13	2.48	3 3/4	6 1/8	6 1/8	6 11/16
325 (3.25")	1 3/8	1-14	1 5/8	3.9	1/2	3 13/16	1 15/16	1 1/4	3/4	11/64	2	1 1/2	5/8	1 1/4	3/8-24	3 3/4	0	1/2	5/8	1.57	1.18	2.76	2 3/4	1 5/8	2.59	2.72	4 1/4	7 3/8	7 3/8	7 7/8
400 (4")	1 3/8	1-14	1 5/8	4.7	1/2	4 1/2	2 1/4	1 1/4	3/4	11/64	2	1 1/2	5/8	1 1/4	3/8-24	4 1/2	0	1/2	5/8	1.57	1.18	3.32	3 1/2	1 5/8	2.59	2.72	4 1/4	7 3/8	7 3/8	7 7/8

Oversized Rod – Front Flange Mounting Type NC A1F (XB5)

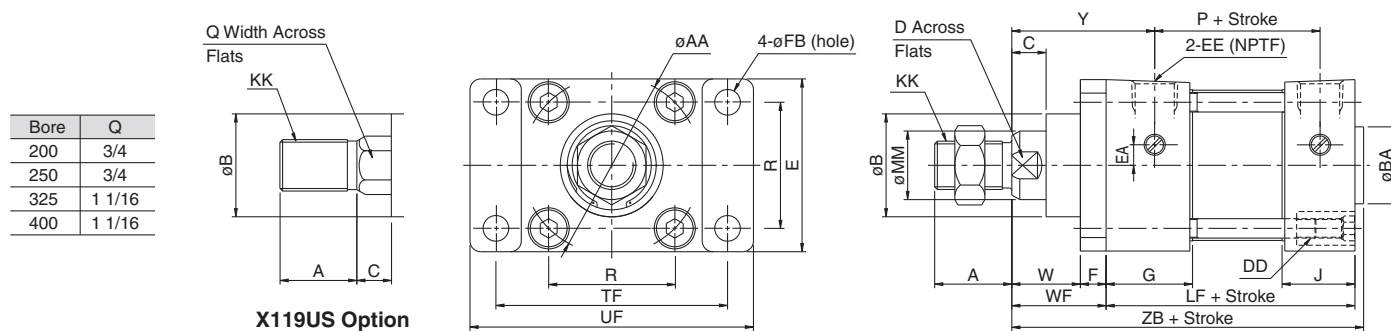

Bore (in)	MM	KK	A	AA	B	BA	C	D	DD	E	EA	EE	F	FB	G	J	R	TF	UF	W	WF	LF	Y	P	ZB
200 (2")	1	3/4-16	1 1/8	2.6	1.5	1 1/8	1/2	7/8	5/16-24	2 1/2	0.3	3/8	3/8	3/8	1.26	1.06	1.84	3 3/8	4 1/8	1	1 3/8	3 5/8	2.09	2.40	5 1/8
250 (2.5")	1	3/4-16	1 1/8	3.1	1.5	1 1/8	1/2	7/8	5/16-24	3	0	3/8	3/8	3/8	1.30	1.06	2.19	3 7/8	4 5/8	1	1 3/8	3 3/4	2.13	2.48	5 1/4
325 (3.25")	1 3/8	1-14	1 5/8	3.9	2	1 1/2	5/8	1 1/4	3/8-24	3 3/4	0	1/2	5/8	7/16	1.57	1.18	2.76	4 11/16	5 1/2	1	1 5/8	4 1/4	2.59	2.72	6 5/64
400 (4")	1 3/8	1-14	1 5/8	4.7	2	1 1/2	5/8	1 1/4	3/8-24	4 1/2	0	1/2	5/8	7/16	1.57	1.18	3.32	5 7/16	6 1/4	1	1 5/8	4 1/4	2.59	2.72	6 5/64

Oversized Rod – Rear Flange Mounting Type NC A1G (XB5)

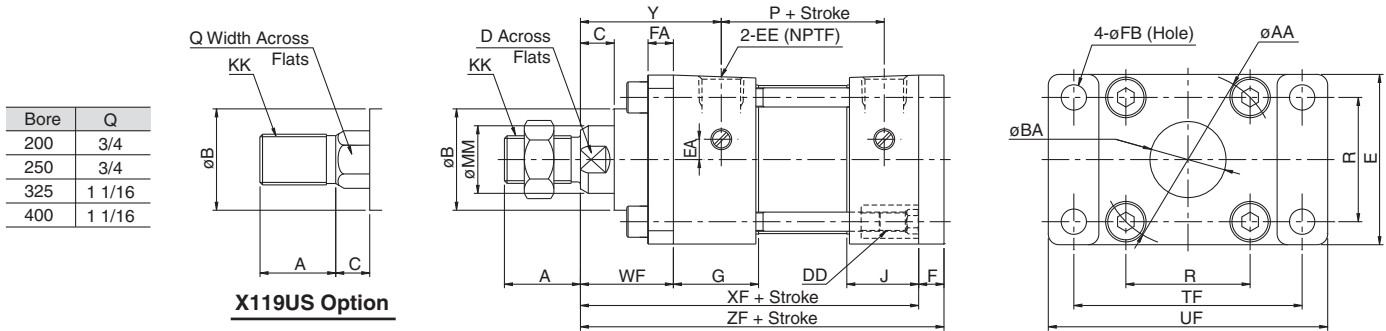

Bore	Q
200	3/4
250	3/4
325	1 1/16
400	1 1/16

X119US Option

																										(in)
Bore (in)	MM	KK	A	AA	B	BA	C	D	DD	E	EA	EE	F	FA	FB	G	J	R	TF	UF	WF	Y	P	XF	ZF	
200 (2")	1	3/4-16	1 1/8	2.6	1.5	1 1/8	1/2	7/8	5/16-24	2 1/2	0.3	3/8	3/8	3/8	3/8	1.26	1.06	1.84	3 3/8	4 1/8	1 3/8	2.09	2.40	5	5 3/8	
250 (2.5")	1	3/4-16	1 1/8	3.1	1.5	1 1/8	1/2	7/8	5/16-24	3	0	3/8	3/8	3/8	3/8	1.30	1.06	2.19	3 7/8	4 5/8	1 3/8	2.13	2.48	5 1/8	5 1/2	
325 (3.25")	1 3/8	1-14	1 5/8	3.9	2	1 1/2	5/8	1 1/4	3/8-24	3 3/4	0	1/2	5/8	5/8	7/16	1.57	1.18	2.76	4 11/16	5 1/2	1 5/8	2.59	2.72	5 7/8	6 1/2	
400 (4")	1 3/8	1-14	1 5/8	4.7	2	1 1/2	5/8	1 1/4	3/8-24	4 1/2	0	1/2	5/8	5/8	7/16	1.57	1.18	3.32	5 7/16	6 1/4	1 5/8	2.59	2.72	5 7/8	6 1/2	

Oversized Rod – Double Detachable Rear Clevis Mounting Type NC A1D (XB5)

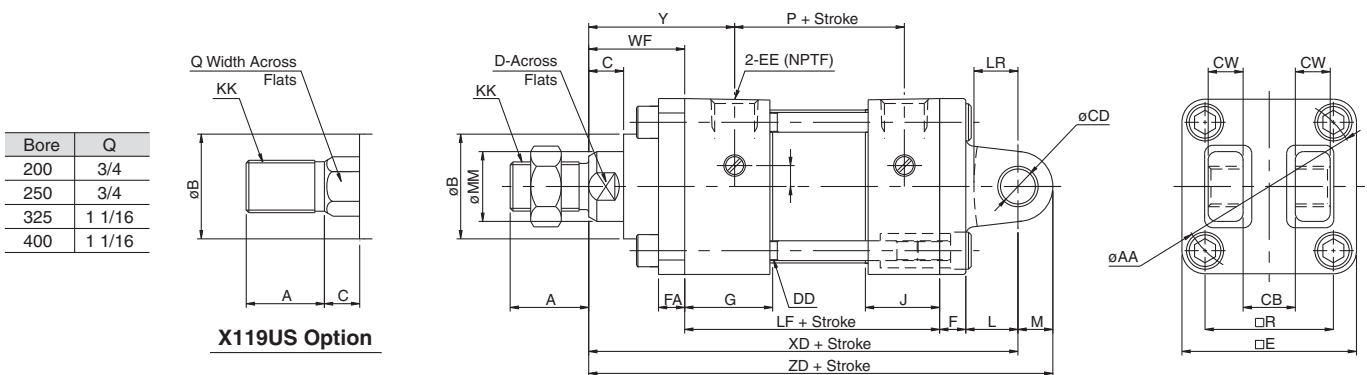

Bore	Q
200	3/4
250	3/4
325	1 1/16
400	1 1/16

X119US Option

																												(in)
Bore (in)	MM	KK	A	AA	B	C	CB	CD	CW	D	DD	E	EA	EE	F	FA	G	J	L	LR	M	R	WF	XD	Y	LF	P	ZD
200 (2")	1	3/4-16	1 1/8	2.6	1 1/2	1/2	3/4	1/2	1/2	7/8	5/16-24	2 1/2	0.3	3/8	3/8	3/8	1.26	1.06	3/4	5/8	1/2	1.84	1 3/8	6 1/8	2.09	3 5/8	2.40	6 5/8
250 (2.5")	1	3/4-16	1 1/8	3.1	1 1/2	1/2	3/4	1/2	1/2	7/8	5/16-24	3	0	3/8	3/8	3/8	1.30	1.06	3/4	5/8	1/2	2.19	1 3/8	6 1/4	2.13	3 3/4	2.48	6 3/4
325 (3.25")	1 3/8	1-14	1 5/8	3.9	2	5/8	1 1/4	3/4	5/8	1 1/4	3/8-24	3 3/4	0	1/2	5/8	5/8	1.57	1.18	1 1/4	1	3/4	2.76	1 5/8	7 3/4	2.59	4 1/4	2.72	8 1/2
400 (4")	1 3/8	1-14	1 5/8	4.7	2	5/8	1 1/4	3/4	5/8	1 1/4	3/8-24	4 1/2	0	1/2	5/8	5/8	1.57	1.18	1 1/4	1	3/4	3.32	1 5/8	7 3/4	2.59	4 1/4	2.72	8 1/2

Oversized Rod – Center Trunnion Mounting Type NC □ A1T (XB5)

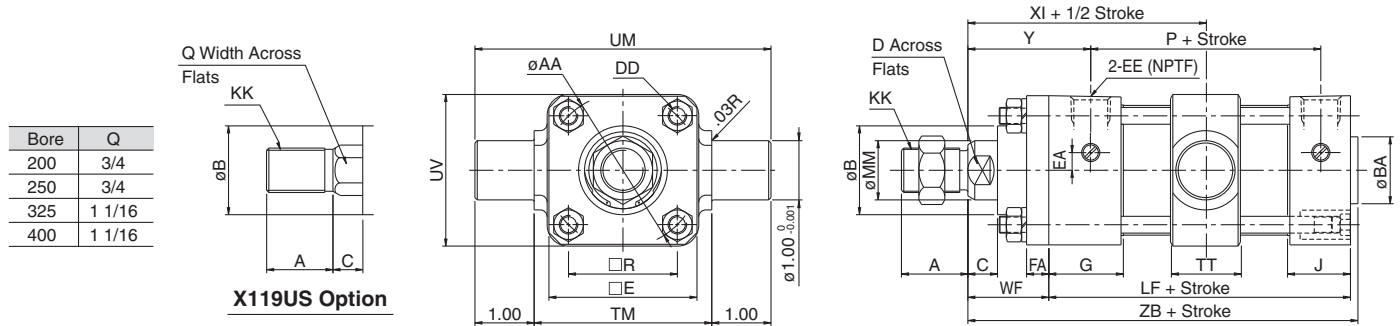

Bore (in)	MM	KK	A	AA	B	BA	C	D	DD	E	EA	EE	FA	G	J	R	TM	TT	UM	UV	WF	Y	LF	P	XI	ZB
200 (2")	1	3/4-16	1 1/8	2.6	1 1/2	1 1/8	1/2	7/8	5/16-24	2 1/2	0.3	3/8	3/8	1.26	1.06	1.84	3	1.18	5	2.56	1 3/8	2.09	3 5/8	2.40	3.29	5 1/8
250 (2.5")	1	3/4-16	1 1/8	3.1	1 1/2	1 1/8	1/2	7/8	5/16-24	3	0	3/8	3/8	1.30	1.06	2.19	3 1/2	1.18	5 1/2	3.39	1 3/8	2.13	3 3/4	2.48	3.37	5 1/4
325 (3.25")	1 3/8	1-14	1 5/8	3.9	2	1 1/2	5/8	1 1/4	3/8-24	3 3/4	0	1/2	5/8	1.57	1.18	2.76	4 1/2	1.34	6 1/2	4.33	1 5/8	2.59	4 1/4	2.72	3.95	6 5/64
400 (4")	1 3/8	1-14	1 5/8	4.7	2	1 1/2	5/8	1 1/4	3/8-24	4 1/2	0	1/2	5/8	1.57	1.18	3.32	5 1/4	1.57	7 1/4	5.12	1 5/8	2.59	4 1/4	2.72	3.99	6 5/64

Oversized Rod – Single Detachable Rear Clevis Mounting Type NC □ A1C (XB5)

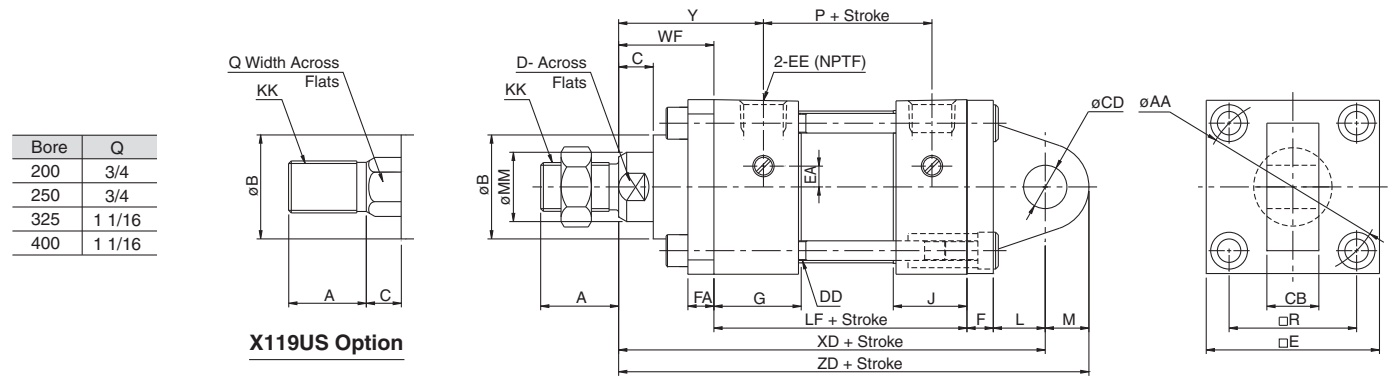

Bore (in)	MM	KK	A	AA	B	C	CB	CD	D	DD	E	EA	EE	F	FA	G	J	L	M	R	WF	XD	Y	LF	P	ZD
200 (2")	1	3/4-16	1 1/8	2.6	1 1/2	1/2	3/4	1/2	7/8	5/16-24	2 1/2	0.3	3/8	3/8	3/8	1.26	1.06	3/4	5/8	1.84	1 3/8	6 1/8	2.09	3 5/8	2.40	6.75
250 (2.5")	1	3/4-16	1 1/8	3.1	1 1/2	1/2	3/4	1/2	7/8	5/16-24	3	0	3/8	3/8	3/8	1.30	1.06	3/4	5/8	2.19	1 3/8	6 1/4	2.13	3 3/4	2.48	6.88
325 (3.25")	1 3/8	1-14	1 5/8	3.9	2	5/8	1 1/4	3/4	1 1/4	3/8-24	3 3/4	0	1/2	5/8	5/8	1.57	1.18	1 1/4	7/8	2.76	1 5/8	7 3/4	2.59	4 1/4	2.72	8.63
400 (4")	1 3/8	1-14	1 5/8	3.9	2	5/8	1 1/4	3/4	1 1/4	3/8-24	4 1/2	0	1/2	5/8	5/8	1.57	1.18	1 1/4	7/8	3.32	1 5/8	7 3/4	2.59	4 1/4	2.72	8.63

Oversized Rod – Double Rear Clevis Mounting Type NC A1X (XB5)

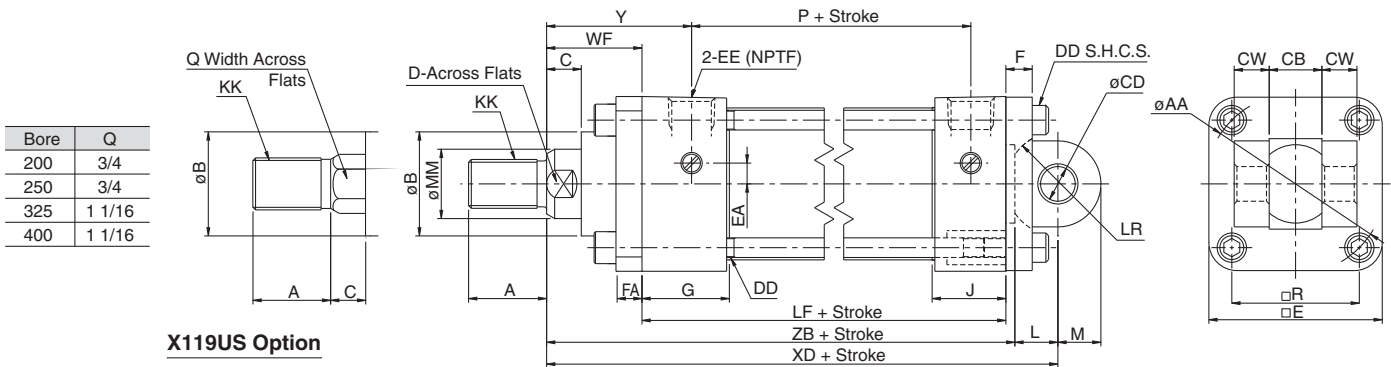

Bore (in)	MM	KK	A	AA	B	C	CB	CD	CW	D	DD	E	EA	EE	F	FA	G	J	L	LR	M	R	WF	XD	Y	LF	P	ZB
200 (2")	1	3/4-16	1 1/8	2.6	1 1/2	1/2	3/4	1/2	1/2	7/8	5/16-24	2 1/2	0.3	3/8	3/8	3/8	1.26	1.06	0.62	3/4	5/8	1.84	1 3/8	5 3/4	2.09	3 5/8	2.40	5 1/8
250 (2.5")	1	3/4-16	1 1/8	3.1	1 1/2	1/2	3/4	1/2	1/2	7/8	5/16-24	3	0	3/8	3/8	3/8	1.30	1.06	0.62	3/4	5/8	2.19	1 3/8	5 7/8	2.13	3 3/4	2.48	5 1/4
325 (3.25")	1 3/8	1-14	1 5/8	3.9	2	5/8	1 1/4	3/4	5/8	1 1/4	3/8-24	3 3/4	0	1/2	5/8	5/8	1.57	1.18	1.05	1 1/4	7/8	2.76	1 5/8	7 1/8	2.59	4 1/4	2.72	6 5/64
400 (4")	1 3/8	1-14	1 5/8	4.7	2	5/8	1 1/4	3/4	5/8	1 1/4	3/8-24	4 1/2	0	1/2	5/8	5/8	1.57	1.18	1.05	1 1/4	7/8	3.32	1 5/8	7 1/8	2.59	4 1/4	2.72	6 5/64

Oversized Rod – Head Trunnion Mounting Type NC A1J (XB5)

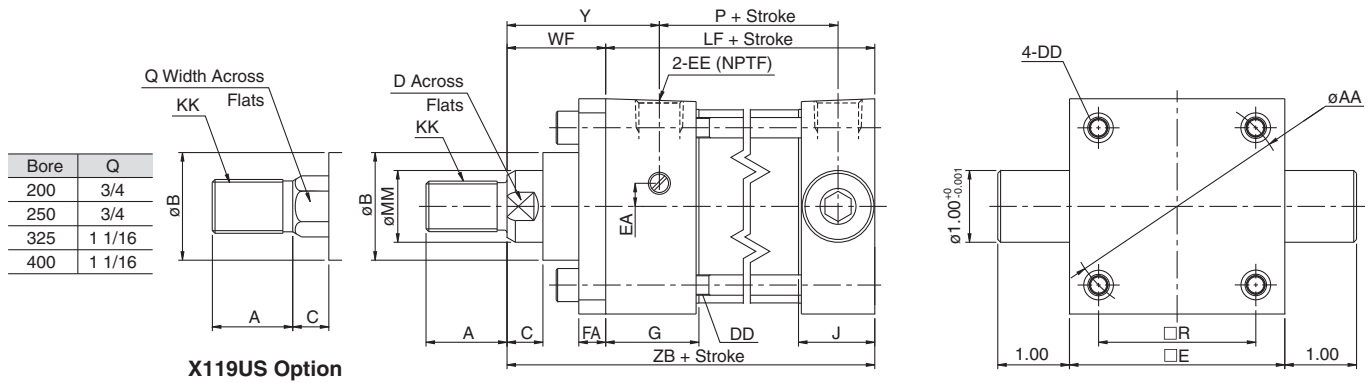

Bore (in)	MM	KK	A	AA	B	C	D	DD	E	EA	EE	FA	G	J	R	WF	Y	LF	P	ZB
200 (2")	1	3/4-16	1 1/8	2.6	1 1/2	1/2	7/8	5/16-24	2 1/2	0.3	3/8	3/8	1.26	1.06	1.84	1 3/8	2.09	3 5/8	2.40	5 1/8
250 (2.5")	1	3/4-16	1 1/8	3.1	1 1/2	1/2	7/8	5/16-24	3	0	3/8	3/8	1.30	1.06	2.19	1 3/8	2.13	3 3/4	2.48	5 1/4
325 (3.25")	1 3/8	1-14	1 5/8	3.9	2	5/8	1 1/4	3/8-24	3 3/4	0	1/2	5/8	1.57	1.18	2.76	1 5/8	2.59	4 1/4	2.72	6 5/64
400 (4")	1 3/8	1-14	1 5/8	4.7	2	5/8	1 1/4	3/8-24	4 1/2	0	1/2	5/8	1.57	1.18	3.32	1 5/8	2.59	4 1/4	2.72	6 5/64

Adjustable Stroke - Extended (XC8)



- The extended stroke stop position is infinitely adjustable within the adjustable range.
- Auto switch capable

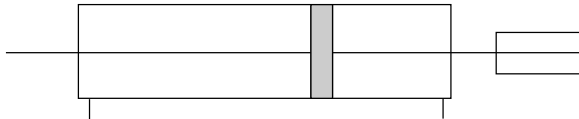

Specifications

Bore size (inch)	1.5	2	2.5	3.25	4
Media	Air				
Max. Operating Pressure	250 psi (17.5 kgf/cm ²)				
Min. Operating Pressure	8 psi (0.5 kgf/cm ²)				
Ambient and Media Temp.	40 to 140°F (5 to 60°C)				
Piston Speed	2 to 20 inch/sec (50 to 500mm/sec)				
Cushion	Air Cushion Standard				
Mounting Types	Basic, Foot, Flange, Center Trunnion, Side Tapped				

Standard Stroke List

Bore size	Standard Stroke (in)
1.5"	1, 2, 3, 4, 5, 6, 8, 10, 12, 14, 16, 18, 20, 24
2", 2.5"	1, 2, 3, 4, 5, 6, 8, 10, 12, 14, 16, 18, 20, 24
3.25", 4"	1, 2, 3, 4, 5, 6, 8, 10, 12, 14, 16, 18, 20, 24, 28, 30

How To Order

NC **D** A1 **B** 150 — 0400 **A** — XC8

Auto Switch Mounting Bore Stroke Adjustment Range
 A: 0~1"
 B: 0~2"
 Adjustable Stroke

Dimensions

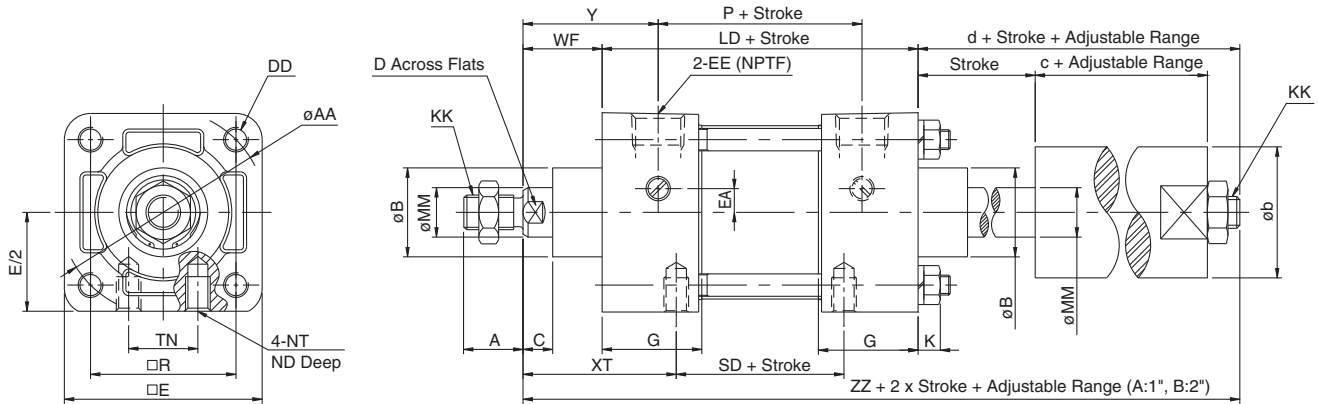

Bore (in)	MM	KK	A	AA	B	C	D	DD	E	EA	EE	G	K	R	WF	Y	LD	P	ZZ	b	c	d	SD	NT	ND	TN
150 (1.5")	5/8	7/16-20	3/4	2.02	1 1/8	3/8	9/16	1/4-28	2	0.3	3/8	1.26	9/32	1.43	1	1.71	3.78	2.36	6.58	1 1/2	1.25	1.80	1.9	1/4-20	9/32	5/8
200 (2")	5/8	7/16-20	3/4	2.6	1 1/8	3/8	9/16	5/16-24	2 1/2	0.3	3/8	1.26	11/32	1.84	1	1.71	3.82	2.40	7.01	1 21/32	1.64	2.19	1.94	5/16-18	7/16	7/8
250 (2.5")	5/8	7/16-20	3/4	3.1	1 1/8	3/8	9/16	5/16-24	3	0	3/8	1.30	11/32	2.19	1	1.75	3.98	2.48	7.17	1 21/32	1.64	2.19	2.1	3/8-16	19/32	1 1/4
325 (3.25")	1	3/4-16	1 1/8	3.9	1 1/2	1/2	7/8	3/8-24	3 3/4	0	1/2	1.57	27/64	2.76	1 3/8	2.34	4.64	2.72	9.38	2 9/32	2.48	3.37	2.52	1/2-13	5/8	1 1/2
400 (4")	1	3/4-16	1 1/8	4.7	1 1/2	1/2	7/8	3/8-24	4 1/2	0	1/2	1.57	27/64	3.32	1 3/8	2.34	4.64	2.72	9.38	2 9/32	2.48	3.37	2.52	1/2-13	5/8	2 1/16

Adjustable Stroke - Return (XC9)



- The return stroke stop position is infinitely adjustable within the adjustable range.
- Auto switch capable

Specifications

Bore size (inch)	1.5	2	2.5	3.25	4
Media	Air				
Max. Operating Pressure	250 psi (17.5 kgf/cm ²)				
Min. Operating Pressure	8 psi (0.5 kgf/cm ²)				
Ambient and Media Temp.	40 to 140°F (5 to 60°C)				
Piston Speed	2 to 20 inch/sec (50 to 500mm/sec)				
Cushion	Air Cushion Standard				
Mounting Types	Basic, Foot, Flange, Center Trunnion, Side Tapped				

Standard Stroke List

Bore size	Standard Stroke (in)
1.5"	1, 2, 3, 4, 5, 6, 8, 10, 12, 14, 16, 18, 20, 24
2", 2.5"	1, 2, 3, 4, 5, 6, 8, 10, 12, 14, 16, 18, 20, 24
3.25", 4"	1, 2, 3, 4, 5, 6, 8, 10, 12, 14, 16, 18, 20, 24, 28, 30

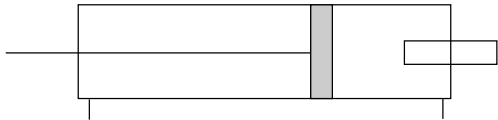

How To Order

NC **D** **A1** **B** **150** — **0400** **A** — **XC9**
 Auto Switch Mounting Bore Stroke Adjustment Range Adjustable Stroke Retract
 A: 0~1" B: 0~2"

Dimensions

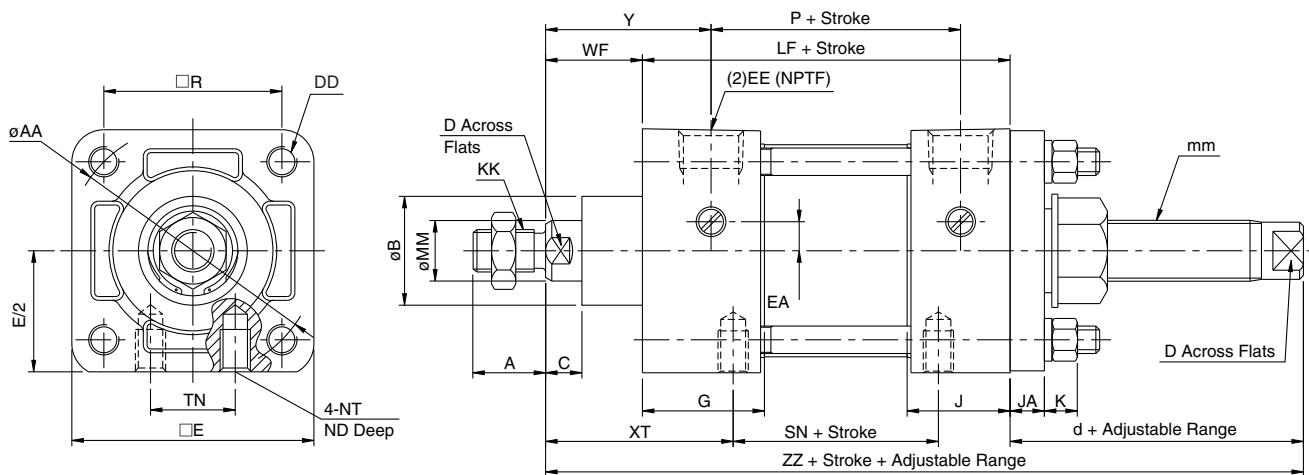

Bore (in)	MM	KK	A	AA	B	C	D	DD	E	EA	EE	G	J	JA	K	R	WF	Y	LF	P	ZZ	TN	XT	SN	d	mm	NT	ND
150 (1.5")	5/8	7/16-20	3/4	2.02	1 1/8	3/8	9/16	1/4-28	2	0.3	3/8	1.26	1.10	11/32	9/32	1.43	1	1.71	3 5/8	2.36	6.44	5/8	1 15/16	2 1/4	1.81	M16 x 1.5	1/4-20	9/32
200 (2")	5/8	7/16-20	3/4	2.6	1 1/8	3/8	9/16	5/16-24	2 1/2	0.3	3/8	1.26	1.06	11/32	11/32	1.84	1	1.71	3 5/8	2.40	6.44	7/8	1 15/16	2 1/4	1.81	M16 x 1.5	5/16-18	7/16
250 (2.5")	5/8	7/16-20	3/4	3.1	1 1/8	3/8	9/16	5/16-24	3	0	3/8	1.30	1.06	11/32	11/32	2.19	1	1.75	3 3/4	2.48	6.44	1 1/4	1 15/16	2 3/8	1.69	M16 x 1.5	3/8-16	19/32
325 (3.25")	1	3/4-16	1 1/8	3.9	1 1/2	1/2	7/8	3/8-24	3 3/4	0	1/2	1.57	1.10	5/8	27/64	2.76	1 3/8	2.34	4 1/4	2.72	8.02	1 1/2	2 7/16	2 5/8	2.40	M24 x 1.5	1/2-13	5/8
400 (4")	1	3/4-16	1 1/8	4.7	1 1/2	1/2	7/8	3/8-24	4 1/2	0	1/2	1.57	1.10	5/8	27/64	3.32	1 3/8	2.34	4 1/4	2.72	8.02	2 1/16	2 7/16	2 5/8	2.40	M24 x 1.5	1/2-13	5/8

Dual Operation - Double Rod (XC10)



Specifications

Bore size (inch)	1.5	2	2.5	3.25	4
Media	Air				
Max. Operating Pressure	250 psi (17.5 kgf/cm ²)				
Min. Operating Pressure	8 psi (0.5 kgf/cm ²)				
Ambient and Media Temp.	40 to 140°F (5 to 60°C)				
Piston Speed	2 to 20 inch/sec (50 to 500mm/sec)				
Cushion	Air Cushion Standard				
Mounting Types	Basic, Foot, Flange, Center Trunnion, Side Tapped				

- 4 positions available from a single cylinder
- Auto switch capable

Standard Stroke List

Bore Size	Standard Stroke (in)
1.5"	1, 2, 3, 4, 5, 6, 8, 10, 12, 14, 16, 18, 20, 24
2", 2.5"	1, 2, 3, 4, 5, 6, 8, 10, 12, 14, 16, 18, 20, 24
3.25", 4"	1, 2, 3, 4, 5, 6, 8, 10, 12, 14, 16, 18, 20, 24, 28, 30

How To Order

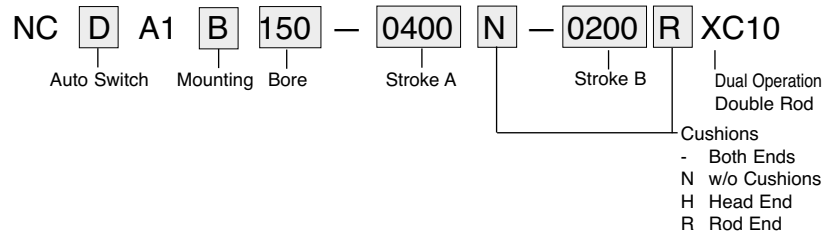

Dimensions

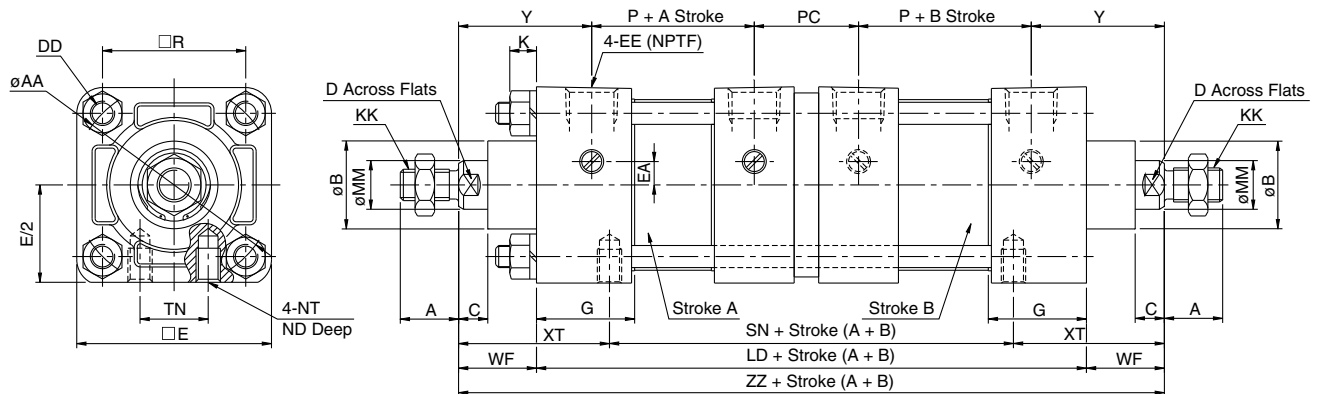

Bore (in)	MM	KK	A	AA	B	C	D	DD	E	EA	EE	G	K	R	WF	Y	LD	P	PC	ZZ	SN	TN	XT	NT	ND
150 (1.5")	5/8	7/16-20	3/4	2.02	1 1/8	3/8	9/16	1/4-28	2	0.3	3/8	1.26	9/32	1.43	1	1.71	7.44	2.36	1.30	9.44	5.56	5/8	1 15/16	1/4-20	9/32
200 (2")	5/8	7/16-20	3/4	2.60	1 1/8	3/8	9/16	5/16-24	2 1/2	0.3	3/8	1.26	11/32	1.84	1	1.71	7.52	2.40	1.30	9.52	5.64	7/8	1 15/16	5/16-18	7/16
250 (2.5")	5/8	7/16-20	3/4	3.1	1 1/8	3/8	9/16	5/16-24	3	0	3/8	1.30	11/32	2.19	1	1.75	7.76	2.48	1.30	9.76	5.88	1 1/4	1 15/16	3/8-16	19/32
325 (3.25")	1	3/4-16	1 1/8	3.9	1 1/2	1/2	7/8	3/8-24	3 3/4	0	1/2	1.57	27/64	2.76	1 3/8	2.34	8.94	2.72	1.57	11.69	6.82	1 1/2	2 7/16	1/2-13	5/8
400 (4")	1	3/4-16	1 1/8	4.7	1 1/2	1/2	7/8	3/8-24	4 1/2	0	1/2	1.57	27/64	3.32	1 3/8	2.34	8.94	2.72	1.57	11.69	6.82	2 1/16	2 7/16	1/2-13	5/8

Dual Operation - Single Rod (XC11)



- 3 positions can be obtained from a single cylinder.
- Twice the force is available for the extended stroke.
- Auto switch capable

Specifications

Bore size (inch)	1.5	2	2.5	3.25	4
Media	Air				
Max. Operating Pressure	250 psi (17.5 kgf/cm ²)				
Min. Operating Pressure	8 psi (0.5 kgf/cm ²)				
Ambient and Media Temp.	40 to 140°F (5 to 60°C)				
Piston Speed	2 to 20 inch/sec (50 to 500mm/sec)				
Cushion	Air Cushion Standard				
Mounting Types	Basic, Foot, Flange, Clevis Side Lug, Side Tapped				

Standard Stroke List

Bore Size	Standard Stroke (in)
1.5"	1, 2, 3, 4, 5, 6, 8, 10, 12, 14, 16, 18, 20, 24
2", 2.5"	1, 2, 3, 4, 5, 6, 8, 10, 12, 14, 16, 18, 20, 24
3.25", 4"	1, 2, 3, 4, 5, 6, 8, 10, 12, 14, 16, 18, 20, 24, 28, 30

Example: NCDA1B150-0200R+0300H-XC11 will stroke 2" then an additional 3" for a total stroke of 5". The front cylinder B (rod end) must be equal to 5" to allow the full stroke.

How To Order

NC **D** **A1** **B** **150** - **0200** **R** + **0300** **H** **XC11**

Auto Switch Mounting Bore Stroke A Stroke B-A Dual Operation Single Rod

Cushions
 - Both Ends
 N w/o Cushions
 H Head End
 R Rod End

Dimensions

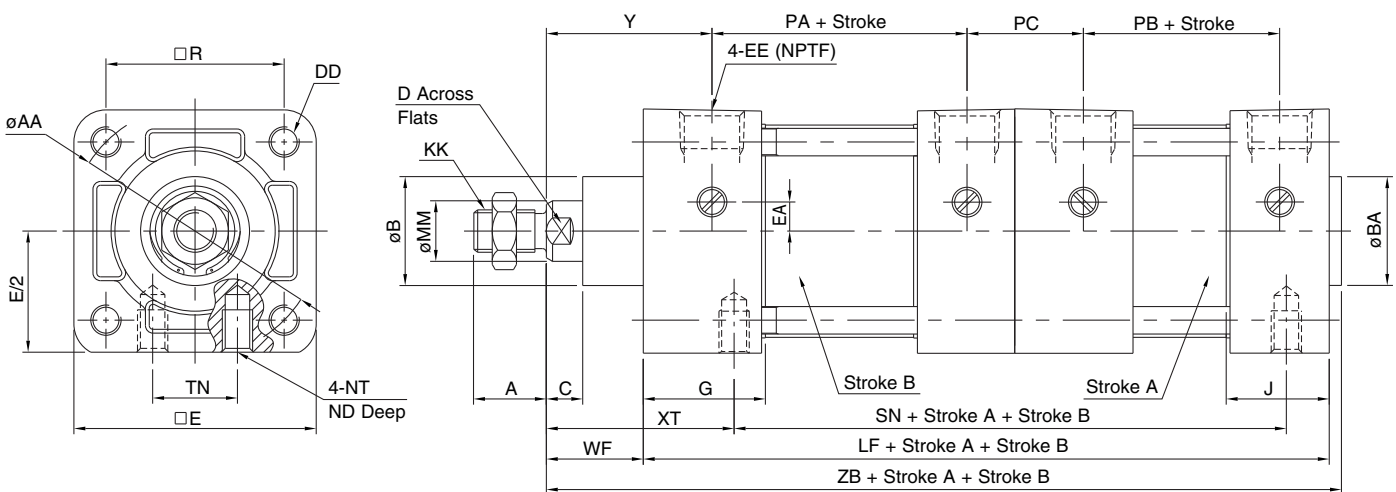

Bore (in)	MM	KK	A	AA	B	BA	C	D	DD	E	EA	EE	G	J	NT	R	TN	WF	XT	Y	LF	PA	PB	PC	SN	ZB	ND
150 (1.5")	5/8	7/16-20	3/4	2.02	1 1/8	1 1/8	3/8	9/16	1/4-28	2	0.3	3/8	1.26	1.1	1/4-20	1.43	5/8	1	1 15/16	1.71	7.26	2.36	2.40	1.24	5.89	8.39	9/32
200 (2")	5/8	7/16-20	3/4	2.60	1 1/8	1 1/8	3/8	9/16	5/16-24	2 1/2	0.3	3/8	1.26	1.06	5/16-18	1.84	7/8	1	1 15/16	1.71	7.26	2.40	2.44	1.20	5.89	8.38	7/16
250 (2.5")	5/8	7/16-20	3/4	3.1	1 1/8	1 1/8	3/8	9/16	5/16-24	3	0	3/8	1.3	1.06	3/8-16	2.19	1 1/4	1	1 15/16	1.75	7.38	2.48	2.52	1.12	6.01	8.50	19/32
325 (3.25")	1	3/4-16	1 1/8	3.9	1 1/2	1 1/2	1/2	7/8	3/8-24	3 3/4	0	1/2	1.57	1.18	1/2-13	2.76	1 1/2	1 3/8	2 7/16	2.34	8.52	2.72	2.76	1.51	6.89	10.1	5/8
400 (4")	1	3/4-16	1 1/8	4.7	1 1/2	1 1/2	1/2	7/8	3/8-24	4 1/2	0	1/2	1.57	1.18	1/2-13	3.32	2 1/16	1 3/8	2 7/16	2.34	8.52	2.72	2.76	1.51	6.89	10.1	5/8

NFPA Standard Piston Rod Threads (1.5" to 4" Bore)

Addition of NFPA Standard Threads for NCA1 Series

The NCA1 series is the NFPA Interchangeable tie-rod actuator and is available in bore sizes 1.5" to 8".

Previously, the only standard rod thread option on NCA1 was a "Small Male" (Nil) thread. The new NFPA rod thread options being added are:

- Short Female (SF)
- Intermediate Male (IM)
- Flanged (F)
- Full Male (FM)
- Plain (PL)

Previously requesting the above rod thread changes required a RFS.

See **next page** for dimensional information on these new NCA1 rod thread offerings.

The current NCA1 rod end standard is "Small Male" (Nil). The additional thread options, listed above, are valid on the entire NCA1 series with the following exceptions:

- *Not valid with K (non-rotating), W (double rod), M (male rod stud), KW (non-rotating, double rod)*
- *Not valid above cylinder stroke of 60.00"*
- *Not valid with J (Nylon Boot) or K (Neoprene Boot)*
- *Not valid with X-Options: XB7 (low temp), XC8 (adjustable stroke extension), XC11 (dual operation/single rod), and X119US (non-rotating oversized rod)*

For all questions, please contact your local SMC sales representative.

NFPA Standard Piston Rod Threads (1.5" to 4" Bore)

How To Order

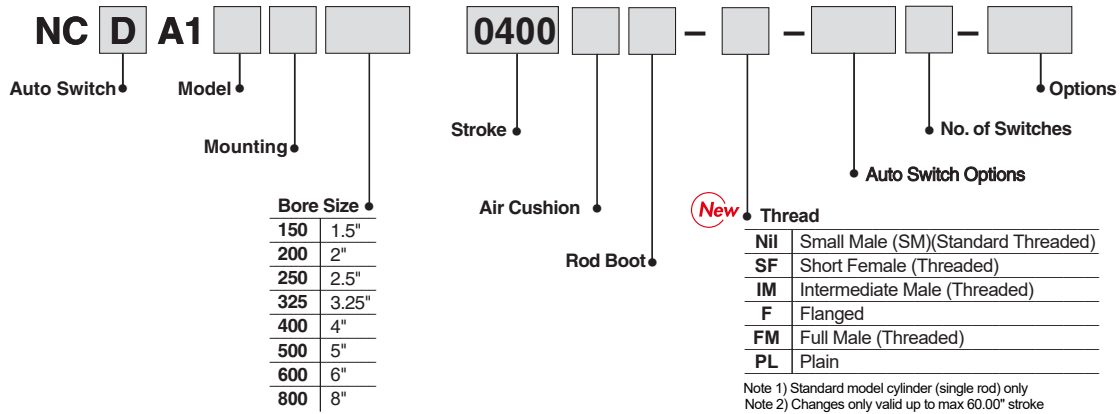

Thread	Description
Nil	Small Male (SM)(Standard Threaded)
SF	Short Female (Threaded)
IM	Intermediate Male (Threaded)
F	Flanged
FM	Full Male (Threaded)
PL	Plain

Note 1) Standard model cylinder (single rod) only
 Note 2) Changes only valid up to max 60.00" stroke
 Note 3) Changes not valid with: Rod Boot, XB7, XC8, XC11, or X119US

SMALL MALE (THREADED) - Nil (SM)
SMC STANDARD

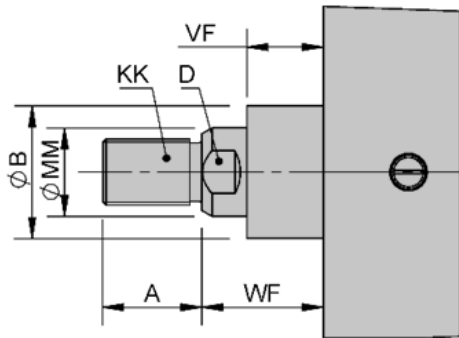

SHORT FEMALE (THREADED) - SF

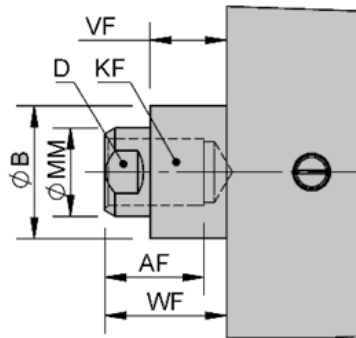

INTERMEDIATE MALE (THREADED) - IM

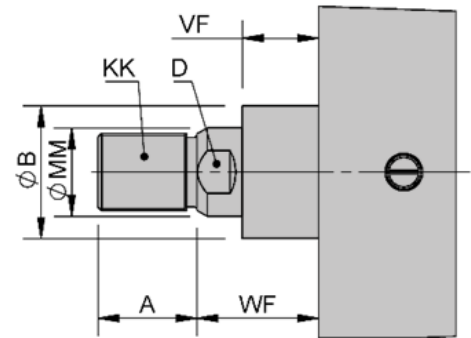

FLANGED - F

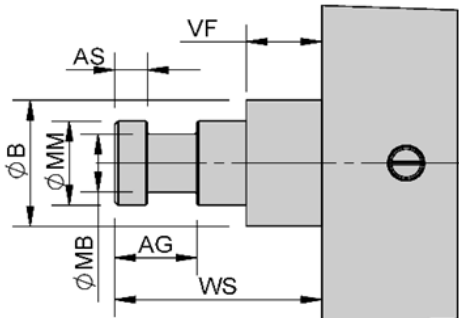

FULL MALE (THREADED) - FM

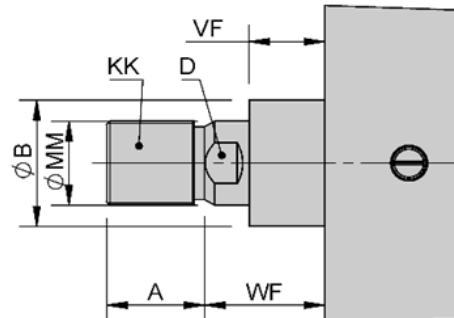

PLAIN - PL

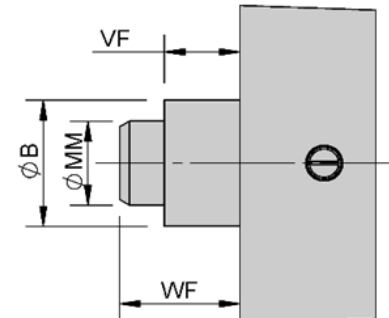

Bore Size (in)	Rod Thread						ØMM	A AF	ØB	D	VF	WF	For Flanged - F Only			
	Nil (SM) KK	SF KF	IM	F	FM	PL							WS	AG	AS	MB
150 (1.5")	7/16-20	7/16-20	1/2-20	No Thread	5/8-18	No Thread	0.625	0.75	1.125	0.56	0.63	1.00	1.75	0.63	0.249	0.38
	7/16-20	7/16-20			5/8-18		0.625	0.75	1.125	0.56	0.63	1.00	1.75	0.63	0.249	0.38
200 (2")	3/4-16	3/4-16	7/8-14	No Thread	1-14	No Thread	1.000	1.13	1.500	0.88	0.88	1.38	2.38	0.94	0.374	0.69
	7/16-20	7/16-20			5/8-18		0.625	0.75	1.125	0.56	0.63	1.00	1.75	0.63	0.249	0.38
250 (2.5")	3/4-16	3/4-16	7/8-14	No Thread	1-14	No Thread	1.000	1.13	1.500	0.88	0.88	1.38	2.38	0.94	0.374	0.69
	7/16-20	7/16-20			5/8-18		0.625	0.75	1.125	0.56	0.63	1.00	1.75	0.63	0.249	0.38
325 (3.25")	3/4-16	3/4-16	7/8-14	No Thread	1-14	No Thread	1.000	1.13	1.500	0.88	0.88	1.38	2.38	0.94	0.374	0.69
	1-14	1-14			1 1/4-12		1.375	1.63	2.000	1.25	1.00	1.63	2.75	1.06	0.374	0.88
400 (4")	3/4-16	3/4-16	7/8-14	No Thread	1-14	No Thread	1.000	1.13	1.500	0.88	0.88	1.38	2.38	0.94	0.374	0.69
	1-14	1-14			1 1/4-12		1.375	1.63	2.000	1.25	1.00	1.63	2.75	1.06	0.374	0.88

Note 1) Dimensions in grey are for oversized rod (XB5)

Accessories

Eye Brackets

Part No	CB	CD	DD	E	F	FL	LR	M	MR	R
NCA1-P150	3/4	1/2	13/32	2 1/2	3/8	1 1/8	3/4	1/2	9/16	1.63
NCA1-P325	1 1/4	3/4	17/32	3 1/2	5/8	1 7/8	1 1/4	3/4	7/8	2.56
NCA1-P800	1 1/2	1	21/32	4 1/2	3/4	2 1/4	1 1/2	1	1 1/4	3.25
NCA1-P1000	2	1 3/8	21/32	5	7/8	3	2 1/8	1 3/8	1 5/8	3.81
NCA1-P1200	2 1/2	1 3/4	29/32	6 1/2	7/8	3 1/8	2 1/4	1 3/4	2 1/8	4.95
NCA1-P1400	2 1/2	2	1 1/16	7 1/2	1	3 1/2	2 1/2	2	2 7/16	5.75
NCA1-P1401	3	2 1/2	1 3/16	8 1/2	1 3/4	4 3/4	2 5/8	2 1/2	3	6.58
NCA1-P1402	3	3	1 5/16	9 1/2	2	5 1/4	2 7/8	2 3/4	3 1/4	7.50

Note: Pivot Pin is not included.

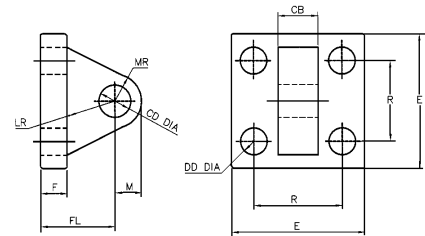

Clevis Brackets

Part No	AA	BA	CB	CD	CW	DD	E	F	FL	LR	M	MR
NCA1-CB150	2.3	1 5/8	0.785	1/2	1/2	3/8 -24	2 1/2	3/8	1 1/8	1/2	1/2	9/16
NCA1-CB325	3.6	2 9/16	1.265	3/4	5/8	1/2 -20	3 1/2	5/8	1 7/8	1 1/16	3/4	1 1/16
NCA1-CB800	4.6	3 1/4	1.515	1	3/4	5/8 -18	4 1/2	3/4	2 1/4	1 1/4	1	1 1/8
NCA1-CB1000	5.4	3 13/16	2.032	1 3/8	1	5/8 -18	5	7/8	3	1 7/8	1 3/8	1 3/4
NCA1-CB1200	7	4 15/16	2.531	1 3/4	1 1/4	7/8 -14	6 1/2	7/8	3 1/8	2	1 3/4	1 7/8
NCA1-CB1400	8.1	5 3/4	2.531	2	1 1/4	1-14	7 1/2	1	3 1/2	2 1/8	2	2 1/8
NCA1-CB1401	9.3	6 19/32	3.032	2 1/2	1 1/2	1 1/8-12	8 1/2	1	4	2 5/8	2 1/2	2 1/2
NCA1-CB1402	10.6	7 1/2	3.032	3	1 1/2	1 1/4-12	9 1/2	1	4 1/4	2 7/8	2 3/4	2 3/4

Note: Pivot Pin is not included.

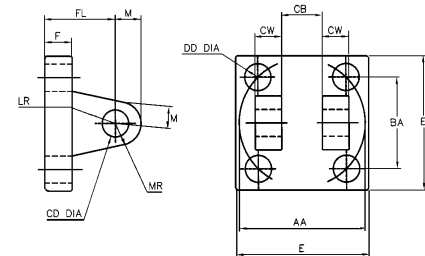

Rod Clevises

Part No	CB	CD	CE	CH	CW	F	L	A	KK	ER
NY-150	0.765	0.5	1 1/2	1	1/2	1	3/4	3/4	7/16-20	1/2
NY-325	1.265	0.75	2 3/8	1 3/8	5/8	1 1/4	1 1/4	1 1/8	3/4-16	3/4
NY-800	1.515	1	3 1/8	1 1/2	3/4	1 1/2	1 1/2	1 5/8	1 -14	1
NY-1000	2.032	1 3/8	4 1/8	2	1	2	2 1/8	2	1 1/4 -12	1 3/8
NY-1200	2.531	1 3/4	4 1/2	2 3/8	1 1/4	2 3/8	2 1/4	2 1/4	1 1/2 -12	1 3/4
NY-1400	2.531	2	5 1/2	2 15/16	1 1/4	2 15/16	2 1/2	3	1 7/8 -12	2
NY-1401	3.032	2 1/2	6 1/2	3 1/2	1 1/2	3 1/2	3	3 1/2	2 1/4 -12	2 1/2
NY-1402	3.032	3	6 3/4	3 7/8	1 1/2	3 7/8	3 1/4	3 1/2	2 1/2 -12	2 3/4

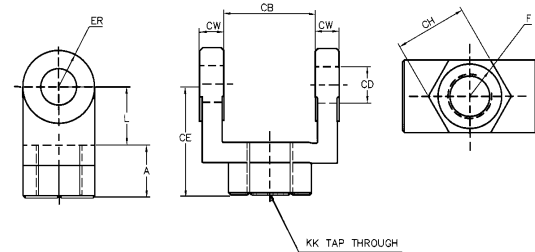

Order to Match Rod Thread

Rod Eyes

Part No	A	CA	CB	CD	ER	KK
NI-150	3/4	1 1/2	3/4	1/2	5/8	7/16 20
NI-325	1 1/8	2 1/16	1 1/4	3/4	7/8	3/4 -16
NI-800	1 5/8	2 13/16	1 1/2	1	1 3/16	1-14
NI-1000	2	3 7/16	2	1 3/8	1 9/16	1 1/4 -12
NI-1200	2 1/4	4	2 1/2	1 3/4	2	1 1/2 -12
NI-1400	3	5	2 1/2	2	2 1/2	1 7/8 -12
NI-1401	3 1/2	5 13/16	3	2 1/2	2 13/16	2 1/4 -12
NI-1402	3 1/2	6 1/8	3	3	3 1/4	2 1/2 -12

Pivot Pin

Part No	CD	CL
NCA1-150	1/2	1 7/8
NCA1-325	3/4	2 5/8
NCA1-800	1	3 1/8
NCA1-1000	1 3/8	4 1/8
NCA1-1200	1 3/4	5 1/8
NCA1-1400	2	5 1/8
NCA1-1401	2.5	6.19
NCA1-1402	3	6.25

Note: Retainer Rings are included.

Pivot Pin

Part No	CD ₁	CD ₂	CL	CP
NCDP-150	.500 ⁰ _{-.002}	.106	2.28	1.94
NCDP-325	.750 ⁰ _{-.002}	.140	3.10	2.72

Note: Cotter Pins are included.

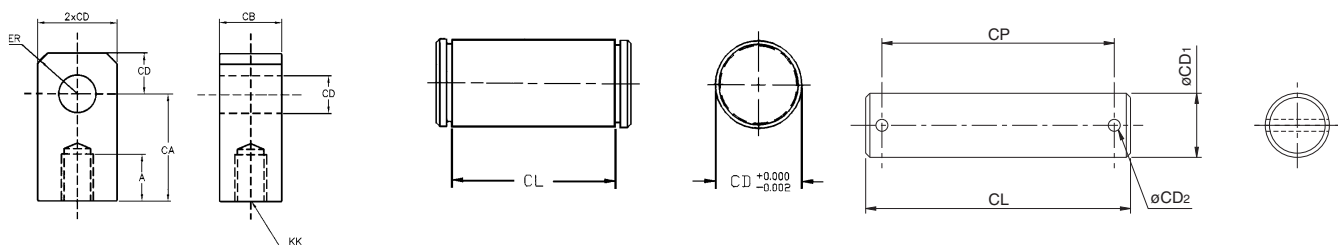

How to Order Auto Switches

Wire Lead Type

D - 

For standard part number please see applicable auto switches on page 41 to 47.

Lead wire length	
Nil	0.5 (m) (1.64 ft)
L	3 (m) (9.84 ft)
Z	5 (m) (16.4 ft)

Connector Type

D -  PC

For standard part number please see applicable auto switches on page 41 to 47.

Lead wire length	
S	0.5 (m)
M	1.0 (m)
L	3.0 (m)

Connector type	
A	M8-3 pins
B	M8-4 Pins
D	M12-4 Pins

Auto Switch Mounting Bracket / Part No.

Bore Model No.	150 (1.5")	200 (2")	250 (2.5")	325 (3/25")	400 (4")
D-A5, D-F5	NBT-150	NBT-200	NBT-200	NBT-325	NBT-325
D-A6, D-J5					

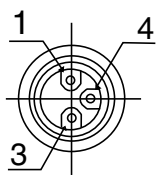
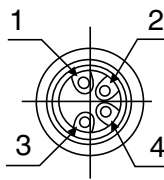
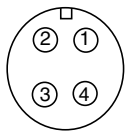
Connector Style	M8-3pins	M8-4pins	M12-4pins
Pin arrangement			
Applicable standards	JIS C 4524, JIS C 4525, IEC 947-5-2, NECA 0402		
Impact resistant	300m/s ²		
IP degree of protection	IP-67 (IEC529 standard)		
Insulation resistance	100MΩ or more at 500VDC meg.		
Withstand voltage	1500VAC 1 minute (between contacts), leakage current 1mA or less.		

Sensor type	Lead wire color				Meaning of contact No.			
	1 pin	2 pin	3 pin	4 pin	1 pin	2 pin	3 pin	4 pin
DC 2-wire	Brown	-	-	Blue	OUT (+)	-	-	OUT (-)
DC 2-wire non-polar	-	-	Brown	Blue	-	-	OUT (+)	OUT (±)
DC 3-wire	Brown	-	Blue	Black	DC (+)	-	DC (-)	OUT
DC 4-wire	Brown	Orange	Blue	Black	DC (+)	Diagnostic Output	DC (-)	OUT

- Connector
M8-3 pins / 4 pins

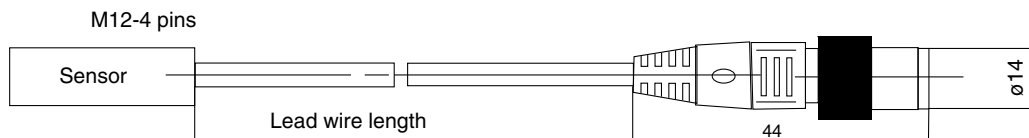
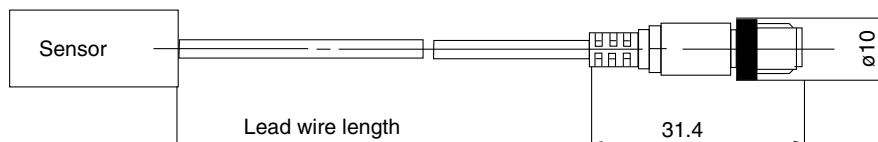

Grommet



Specifications

PLC: Programmable Logic Controller

D-A5 (With indicator light)					
Auto switch model number	D-A53	D-A54		D-A56	
Application	PLC	Relay/PLC		IC circuit	
Load voltage	24VDC	24VDC	100VAC	200VAC	4 to 8VDC
Max. load current and range	5 to 50mA	5 to 50mA	5 to 25mA	5 to 12.5mA	20mA
Contact protection circuit	None	Built-in		None	
Internal voltage drop	2.4V			0.8V or less	
Indicator light	ON: When red light emitting diode				

D-A6 (Without indicator light)				
Auto switch model number	D-A64			D-A67
Application	Relay/PLC			PLC/IC circuit
Load voltage	$\leq 24V_{DC}^{AC}$	100VAC	200VAC	Max. 24VDC
Max. load current	50mA	25mA	12.5mA	30mA
Contact protection circuit	Built-in			None
Internal resistance	$\leq 10\Omega$			$\leq 1\Omega$ (Including 3m lead wire)

- Lead wire — Oilproof vinyl heavy insulation cable, $\phi 4$, 0.3mm², 2 cores (Brown, Blue), 0.5m or $\phi 4$, 0.2mm², 3 cores (Brown, Black, Blue), 0.5m
- Refer to common specifications and lead wire length on page 48.

Internal Circuit

(): If not applicable for IEC Standard

D-A53

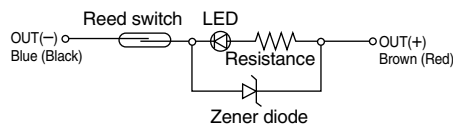

D-A54

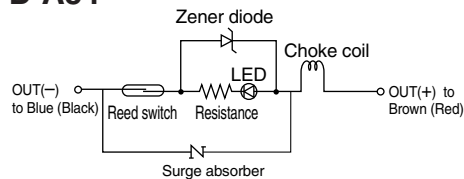

D-A56

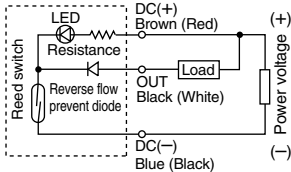

D-A64

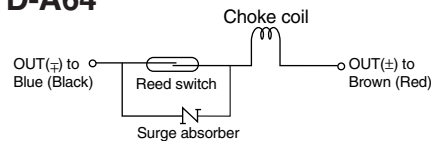

D-A67

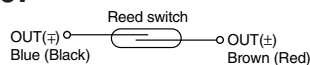

Dimensions

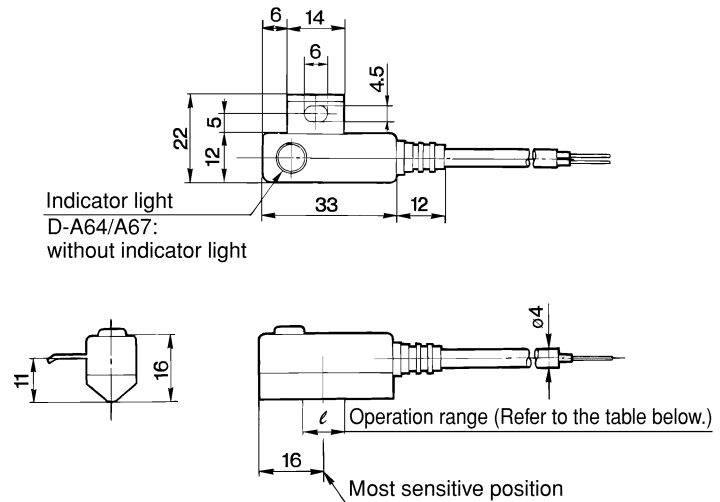

Operation Range (ℓ Dimension) (in)

Actuator series	Bore size				
	1 1/2	2	2 1/2	3 1/4	4
NCA1	.354	.393	.433	.433	.433

Note: Average value at normal temperature including hysteresis. (Tolerance $\pm 30\%$)

Grommet

The suitable operating point can be indicated with a green light.
(Red → Green ← Red)



Specifications

PLC: Programmable Logic Controller

D-A59W (With indicator light)	
Auto switch model number	D-A59W
Application	Relay/PLC
Load voltage	24VDC
Load current range	5 to 40mA
Contact protection circuit	Built-in
Internal voltage drop	≤ 4V
Indicator light	Operating point: Red light emitting diode Suitable operating point: Green light emitting diode

- Lead wire — Oilproof vinyl heavy insulation cable, $\phi 4$, 0.3mm², 2 cores (Brown, Blue), 0.5m
- Refer to common specifications and lead wire length on page 48.

Internal Circuit

(): If not applicable for IEC Standard

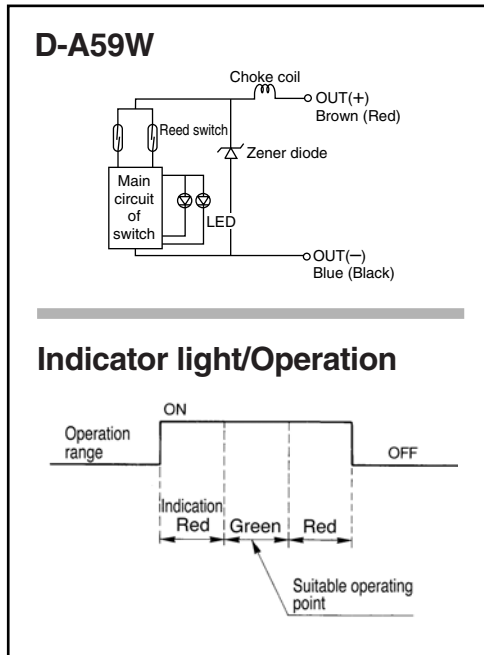

Dimensions

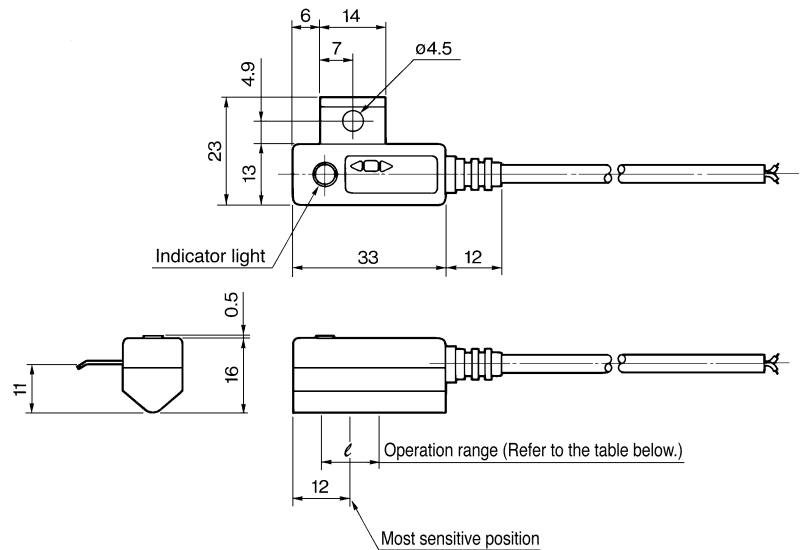

Operation Range (ℓ Dimension) (in)

Actuator series	Bore size				
	1 1/2	2	2 1/2	3 1/4	4
NCA1	.354	.393	.433	.433	.433

Note: Average value at normal temperature including hysteresis. (Tolerance ± 30%)

Grommet



Internal Circuit (): If not applicable for IEC Standard

D-F59

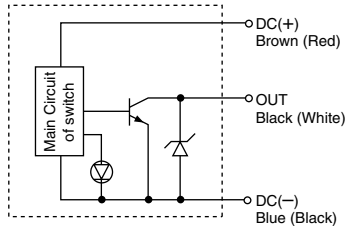

D-F5P

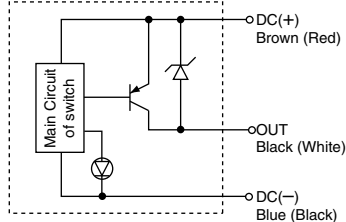

D-J59

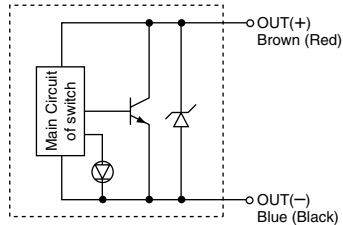

D-J51

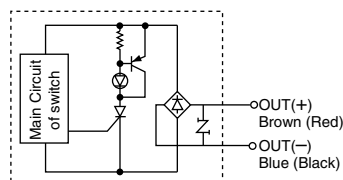

Specifications

PLC: Programmable Logic Controller

D-F5□/ D-J5□				
Auto switch model number	D-F59	D-F5P	D-J59	D-J51
Wiring	3 wire		2 wire	
Output	NPN	PNP	—	—
Application	IC circuit/Relay/PLC		24VDC Relay/PLC	AC Relay/PLC
Power voltage	5/12/24VDC (4.5 to 28VDC)		—	—
Current consumption	≤ 10mA		—	—
Load voltage	≤ 28VDC	—	24VDC (10 to 28VDC)	80 to 260VAC
Load current	≤ 40mA	≤ 80mA	5 to 40mA	5 to 80mA
Internal voltage drop	1.5V or less (0.8V or less at 10mA of load current)	0.8V or less	4V or less	14V or less
Current leakage	≤ 100μA at 24VDC		≤ 0.8mA at 24VDC	≤ 1mA at 100 VDC ≤ 1.5mA at 200VDC
Indicator light	ON: When red light emitting diode			

- Lead wire — Oilproof vinyl heavy insulation cable, $\phi 4$, 0.3mm², 3 cores (Brown, Black, Blue), 2 cores (Brown, Blue), 0.5m
- Refer to common specifications and lead wire length on page 48.

Dimensions

*D-J51 differs in the shape, most sensitive position and operation range from other switches. Contact SMC for the details.

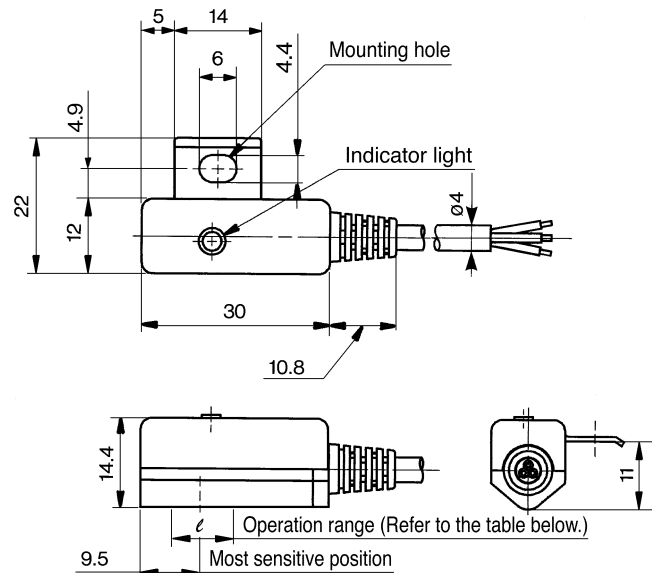

Operation Range (ℓ Dimension) (in)

Actuator series	Bore size				
	1 1/2	2	2 1/2	3 1/4	4
NCA1	.354	.393	.433	.433	.433

Note: Average value at normal temperature including hysteresis. (Tolerance $\pm 30\%$)

Grommet

The output signal can be detected in an unsteady detecting area.



Internal Circuit

(): If not applicable for IEC Standard

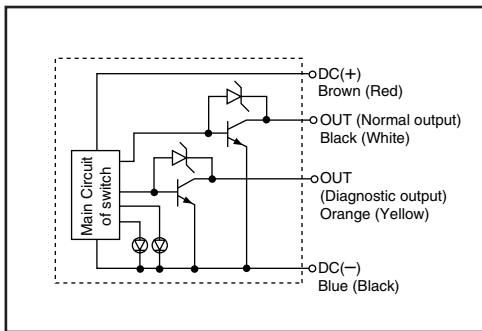

Specifications

PLC: Programmable Logic Controller

D-F59F	
Auto switch model number	D-F59F
Wiring	4 wire
Output	NPN
Diagnostic output	Normal operation
Application	IC circuit/Relay/PLC
Power voltage	5/12/24VDC (4.5 to 28VDC)
Current consumption	≤ 10mA
Load voltage	≤ 28VDC
Load current	≤ 40mA
Internal voltage drop	≤ 1.5V (≤ 0.8V at 10mA)
Current leakage	≤ 100μA at 24VDC
Indicator light	Operating point: Red light emitting diode Suitable operating point: Green light emitting diode

- Lead wire — Oilproof vinyl heavy insulation cable, $\phi 4$, 0.2mm², 4 cores (Brown, Black, Orange, Blue), 0.5m
- Refer to common specifications and lead wire length on page 48.

Diagnostic Output Operation

The diagnostic output is detected when detecting position remains at unsteady area only, not available at the most suitable operating area, that is to say, diagnostic signal can be output only when the detecting position is far from the suitable position for normal operation.

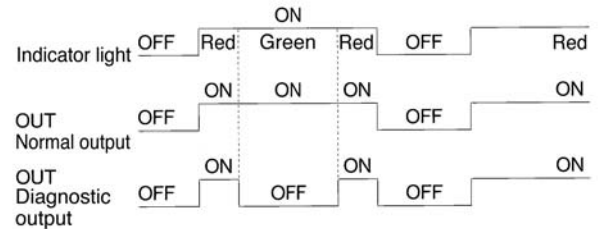

Dimensions

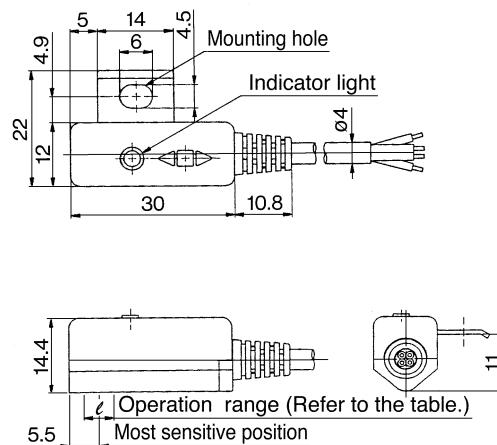

Operation Range (ℓ Dimension) (in)

Actuator series	Bore size				
	1 1/2	2	2 1/2	3 1/4	4
NCA1	.354	.393	.433	.433	.433

Note: Average value at normal temperature including hysteresis. (Tolerance ± 30%)

Grommet

The suitable operating point can be indicated with a green light.
(Red→Green←Red)



Internal Circuit

(): If not applicable for IEC Standard

D-F59W

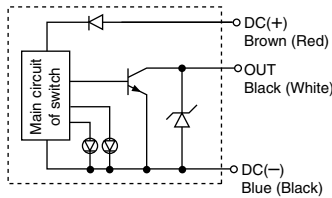

D-F5PW

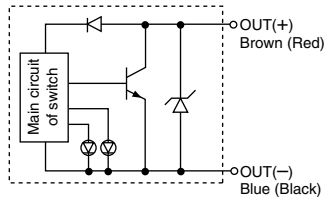

D-J59W

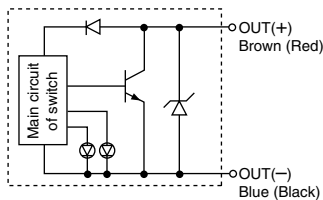

Indicator light/Operation

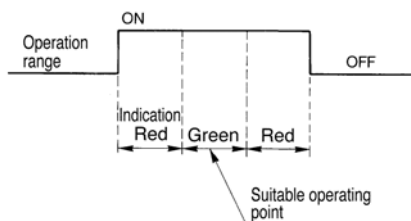

Specifications

PLC: Programmable Logic Controller

D-F5□W/D-J59W (With indicator light)

Auto switch model number	D-F59W	D-F5PW	D-J59W
Wiring	3 wire		2 wire
Output	NPN	PNP	—
Application	IC circuit/Relay/PLC		24VDC Relay/PLC
Power voltage	5/12/24VDC (4.5 to 28VDC)		—
Current consumption	10mA		—
Load voltage	≤ 28VDC	—	24VDC (10 to 28VDC)
Load current	≤ 40mA	≤ 80mA	5 to 40mA
Internal voltage drop	≤ 0.8V (≤ 1.5V at 10mA load current)	≤ 0.8V	≤ 4V
Current leakage	≤ 100μA at 24VDC		≤ 0.8mA at 24VDC
Indicator light	Operating point: Red light emitting diode Suitable operating point: Green light emitting diode		

- Lead wire — Oilproof vinyl heavy insulation cable, ø4, 0.3mm², 3 cores (Brown, Black, Blue), 2 cores (Brown, Blue), 0.5m
- Refer to common specifications and lead wire length on page 48.

Dimensions

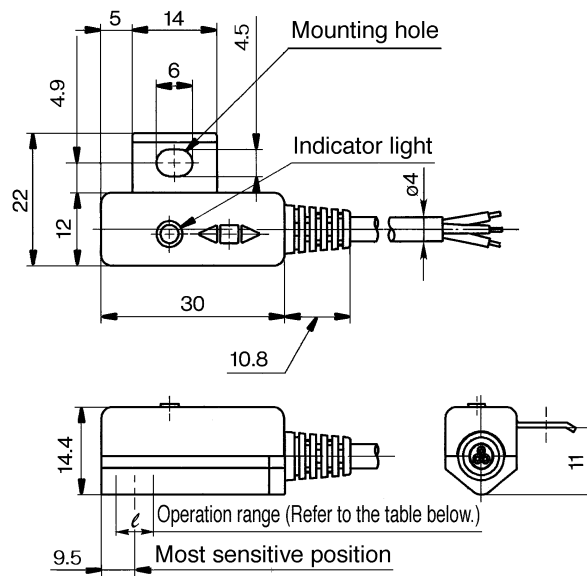

Operation Range (ℓ Dimension) (in)

Actuator series	Bore size				
	1 1/2	2	2 1/2	3 1/4	4
NCA1	.354	.393	.433	.433	.433

Note: Average value at normal temperature including hysteresis. (Tolerance ± 30%)

Grommet

Water (coolant) resistant performance



Caution

Precautions

Consult SMC if using coolant liquid other than water based solution.

Internal Circuit

(): If not applicable for IEC Standard

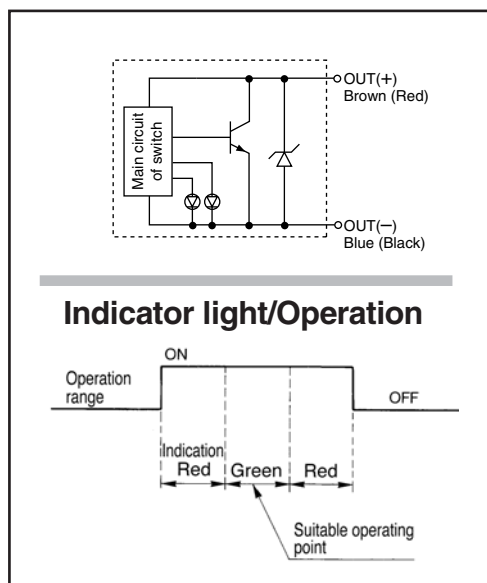

Specifications

PLC: Programmable Logic Controller

D-F5BAL (With indicator light)

Auto switch model number	D-F5BAL
Wiring	2 wire
Output	—
Application	24VDC Relay/PLC
Power voltage	—
Current consumption	—
Load voltage	24VDC (10 to 28VDC)
Load current	≤ 5 to 40mA
Internal voltage drop	≤ 4V
Current leakage	≤ 0.8mA at 24VDC
Indicator light	Operating point: Red light emitting diode Suitable operating point: Green light emitting diode

- Lead wire — Oilproof vinyl heavy insulation cable, ø4, 0.3mm², 2 cores (Brown, Blue), 3m (Standard)
- Refer to common specifications and lead wire length on page 48.

Dimensions

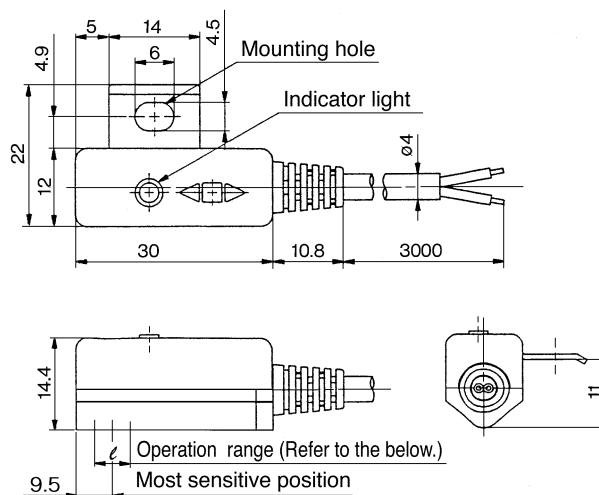

Operation Range (ℓ Dimension) (in)

Actuator series	Bore size				
	1 1/2	2	2 1/2	3 1/4	4
NCA1	.354	.393	.433	.433	.433

Note: Average value at normal temperature including hysteresis. (Tolerance ± 30%)

Grommet

With built-in OFF-delay timer
(200ms)



Internal Circuit

(): If not applicable for IEC Standard

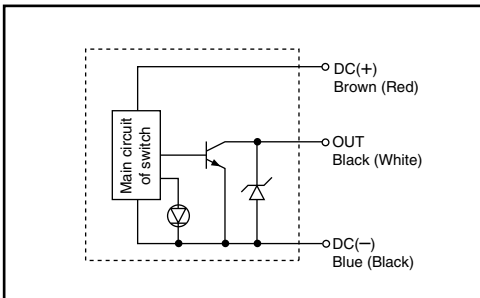

Specifications

PLC: Programmable Logic Controller

D-F5NTL (With indicator light)

Auto switch model number	D-F5NTL
Wiring	3 wire
Output	NPN
Output operation	Off-delay
Operation time	≤ 1ms
Off-delay time	200±50ms
Application	IC circuit/Relay/PLC
Power voltage	5/12/24VDC (4.5 to 28VDC)
Current consumption	≤ 10mA
Load voltage	≤ 28VDC
Load current	≤ 80mA
Internal voltage drop	≤ 1.5V (≤ 0.8V at 10mA)
Current leakage	≤ 100μA at 24VDC
Indicator light	ON: When red light emitting diode

• Lead wire — Oilproof vinyl heavy insulation cable, ø4, 0.3mm², 3 cores (Brown, Black, Blue), 3m (Standard)

• Refer to common specifications and lead wire length on page 48.

Timer Operation

Detection of immediate positioning for high-speed cylinder

Detecting point dispersion occurs due to response time of PLC (sequencer); e. g. scanning.

Ex.) Cylinder speed-1000 mm/sec.

Sequencer response time-0.1 sec.

Detecting point dispersion-Within 100mm (=1000mm/sec. x 0.1sec.)

Take PLC response time into consideration when using.

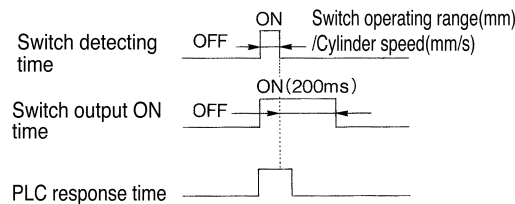

Dimensions

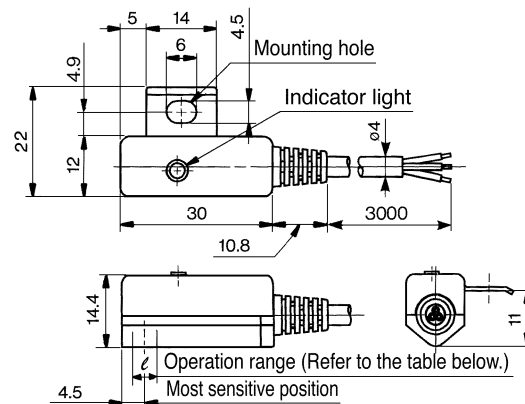

Operation Range (ℓ Dimension) (in)

Actuator series	Bore size				
	1 1/2	2	2 1/2	3 1/4	4
NCA1	.354	.393	.433	.433	.433

Note) Average value at normal temperature including hysteresis. (Tolerance ± 30%)

Auto Switch Specification

Auto Switch Common Specifications

Auto switch style	Reed switch	Solid state switch
Current leakage	None	3-wire: 100 μA or less, 2-wire: 1mA or less
Operating time	1.2ms	1ms or less ^{Note 3)}
Shock resistance	300m/s ²	1000m/s ²
Insulation resistance	50 M Ω or more at 500MVDC (between lead wire and the case)	
Withstand voltage	1500VAC/min. (between lead wire and the case) ^{Note 1)}	1000VAC/min. (between lead wire and the case)
Ambient temperature	-10 to 60°C	
Protective construction	IEC529 Standard IP67, Waterproof construction (JISC0920) ^{Note 2)}	

Note 1) Connector style (D-A73C/A80C/C73C/C80C) and D-9/9□A/A9/A9□V style: 1000VAC/min. (between lead wire and the case)

Note 2) IEC529 Standard IP63, Rainproof construction (JISC0920) for Terminal conduit style (D-A3/A3□A/A3□C/G39/G39A/G39C/K39/K39A/K39C) and DIN terminal style (D-A44/A44A/A44C).

Note 3) Except solid state switch with timer (D-M5□TL, G5NLT, F7NLT, F5NLT) and **Auto switch for strong magnetic field resistance (D-P5DWL)**.
D-J51: 5ms or less

Lead Wire Length

D-A73 **L**

● Lead wire length

Nil	0.5m
L	3m
Z	5m
N*	None

* Applicable for the connector style (D- ** C) only

- Applicable auto switch with 5 meter lead wire ("Z") Reed switch: D-B53/B54, D-C73 (C)/C80C, D-A73(C)(H)/A80C, D-A53/A54, D-Z73, D-90/97/90A/93A
Solid state switch: Manufactured upon receipt of order as standard (Except D-F9/F9IV)
- The standard lead wire length of solid state switch with timer or with water resistant 2-color indication is 3 meters. (Not available 0.5m)
- The standard lead wire length of strong magnetic field resistant solid state switch is 3 or 5 meters. (Not available 0.5m)

Part No. of lead wire with connector

(Available for connector style only.)

Part No.	Lead wire length
D-LC05	0.5m
D-LC30	3m
D-LC50	5m





Series NCA1

Safety Instructions

These safety instructions are intended to prevent a hazardous situation and/or equipment damage. These instructions indicate the level of potential hazard by a label of "**Caution**", "**Warning**" or "**Danger**". To ensure safety, be sure to observe ISO 4414 Note 1), JIS B 8370 Note 2) and other safety practices.

 **Caution** : Operator error could result in injury or equipment damage.

 **Warning** : Operator error could result in serious injury or loss of life.

 **Danger** : In extreme conditions, there is a possible result of serious injury or loss of life.

Note 1) ISO 4414: Pneumatic fluid power – Recommendations for the application of equipment to transmission and control systems

Note 2) JIS B 8370: General Rules for Pneumatic Equipment

Warning

1. The compatibility of pneumatic equipment is the responsibility of the person who designs the pneumatic system or decides its specifications.

Since the products specified here are used in various operating conditions, their compatibility for the specific pneumatic system must be based on specifications or after analysis and/or tests to meet your specific requirements.

2. Only trained personnel should operate pneumatically operated machinery and equipment.

Compressed air can be dangerous if handled incorrectly. Assembly, handling or repair of pneumatic systems should be performed by trained and experienced operators.

3. Do not service machinery/equipment or attempt to remove components until safety is confirmed.

1. Inspection and maintenance of machinery/equipment should only be performed after confirmation of safe locked-out control positions.
2. When equipment is to be removed, confirm the safety process as mentioned above. Cut the supply pressure for this equipment and exhaust all residual compressed air in the system.
3. Before machinery/equipment is restarted, take measures to prevent shooting-out of cylinder piston rod, etc. (Bleed air into the system gradually to create back pressure.)

4. Contact SMC if the product is to be used in any of the following conditions:

1. Conditions and environments beyond the given specifications, or if product is used outdoors.
2. Installation on equipment in conjunction with atomic energy, railway, air navigation, vehicles, medical equipment, food and beverages, recreation equipment, emergency stop circuits, press applications, or safety equipment.
3. An application which has the possibility of having negative effects on people, property, or animals, requiring special safety analysis.

Series NCA1

Actuator Precautions 1

Be sure to read before handling.

Design

Warning

1. There is a possibility of danger of sudden action by air cylinders if sliding parts of machinery are twisted, due to external forces, etc.

In such cases, human injury may occur; e.g., by catching hands or feet in the machinery, or damage to the machinery itself may occur. Therefore, the machine should be adjusted to operate smoothly and designed to avoid such dangers.

2. A protective cover is recommended to minimize the risk of personal injury.

If a stationary object and moving parts of a cylinder are in close proximity, personal injury may occur. Design the structure to avoid contact with the human body.

3. Securely tighten all stationary parts and connected parts so that they will not become loose.

Especially when a cylinder operates with high frequency or is installed where there is a lot of vibration, ensure that all parts remain secure.

4. A deceleration circuit or shock may be required.

When a driven object is operated at high speed or the load is heavy, a cylinder's cushion will not be sufficient to absorb the impact. Install a deceleration circuit to reduce the speed before cushioning, or install an external shock absorber to relieve the impact. In this case, the rigidity of the machinery should also be examined.

5. Consider a possible drop in circuit pressure due to a power outage, etc.

When a cylinder is used in a clamping mechanism, there is a danger of work pieces dropping if there is a decrease in clamping force due to a drop in circuit pressure caused by a power outage, etc. Therefore, safety equipment should be installed to prevent damage to machinery and/or human injury. Suspension mechanisms and lifting devices also require consideration for drop prevention.

6. Consider a possible loss of power source.

Measures should be taken to protect against bodily injury and equipment damage in the event that there is a loss of power to equipment controlled by pneumatics, electricity or hydraulics, etc.

7. Design circuit that will prevent the driven object from shooting out.

The driven object will shoot out at a high speed if one side of the cylinder is pressurized after the air inside the cylinder is exhausted; for example, when the cylinder is driven with exhaust center directional control valves or when it is started after the residual pressure inside the circuit is exhausted.

Such an event can possibly lead to bodily injury, by, for example catching in human limbs, or damage to the machinery. Therefore, select equipment and design circuits to prevent shoot-outs.

8. Consider emergency stops.

Design so that human injury and/or damage to machinery and equipment will not be caused when machinery is stopped by a safety device under abnormal conditions, a power outage or a manual emergency stop.

9. Consider the action when operation is restarted after an emergency stop or abnormal stop.

Design the machinery so that human injury or equipment damage will not occur upon restart of operation. When the cylinder has to be reset at the starting position, install safe manual control equipment.

Selection

Warning

1. Check the specifications.

The products featured in this catalog are designed for use in industrial compressed air systems. If the products are used in conditions where pressure and /or temperature are outside range of specification, damage and/or malfunction may occur. Do not use in these conditions. (Refer to specifications.)

Consult SMC if you use a fluid other than compressed air.

2. Intermediate stops

When intermediate stopping of a cylinder piston is performed with a 3 position closed center type directional control valve, it is difficult to achieve stopping positions as accurate and precise as with hydraulic pressure due to the compressibility of air.

Furthermore, since valves and cylinders, etc., are not guaranteed for zero air leakage, it may not be possible to hold a stopped position for an extended period of time. Contact SMC in case it is necessary to hold a stopped position for an extended period.

Caution

1. Operate within the limits of the maximum usable stroke.

The piston rod will be damaged if operated beyond the maximum stroke. Refer to the cylinder model selection procedure for the maximum useable stroke.

2. Operate the piston within a range such that collision damage will not occur at the stroke end.

The operation range should prevent damage from occurring when a piston, having inertial force, stop by striking the cover at the stroke end. Refer to the cylinder model selection procedure for the maximum useable stroke.

3. Use a speed controller to adjust the cylinder drive speed, gradually increasing from a low speed to the desired speed setting.

4. Provide intermediate supports for long stroke cylinders.

An intermediate support should be provided in order to prevent damage to a cylinder having a long stroke, due to problems such as sagging of the rod deflection of the cylinder tube, vibration and external load.

Series NCA1 Actuator Precautions 2

Be sure to read before handling.

Mounting

⚠ Caution

1. **Be certain to match the rod shaft center with the load and direction of movement when connecting.**

When not properly matched, problem may arise with the rod and tube, and damage may be caused due to friction on areas such as the inner tube surface, bushings, rod surface, and seals.

2. **When an external guide is used, connect the rod end and the load in such a way that there is no interference at any point within the stroke.**

3. **Do not scratch or gouge the sliding parts of the cylinder tube or piston rod by striking or grasping them with other objects.**

Cylinder bores are manufactured to precise tolerances, so that even a slight deformation may cause faulty operation.

Moreover scratches or gouges, etc., in the piston rod may lead to damaged seals and cause air leakage.

4. **Prevent the seizure of rotating parts.**

Prevent the seizure of rotating parts (pins, etc.) by applying grease.

5. **Do not use until you can verify that equipment can operate properly.**

After mounting, repairs, or modification, etc., connect the air supply and electric power, and then confirm proper mounting by means of appropriate function and leak tests.

6. **Instruction manual**

The product should be mounted and operated after the instruction manual is thoroughly read and its contents are understood.

Keep the instruction manual where it can be referred to as needed.

1. **Preparation before piping**

Before piping is connected, it should be thoroughly blown out with air (flushing) or washed to remove chips, cutting oil and other debris from inside the pipe.

2. **Wrapping of pipe tape**

When screwing together pipes and fittings, etc., be certain that chips from the pipe threads and sealing material do not get inside the piping.

Also, when sealant tape is used, leave 1.5 to 2 thread ridges exposed at the end of the threads.

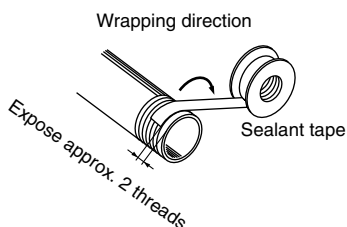

Cushion

⚠ Caution

1. **Readjust using the cushion needle.**

Cushions are adjusted at the time of shipment, however, the cushion needle on the cover should be readjusted when the product is put into service, based upon factors such as the size of the load and the operating speed. When the cushion needle is turned clockwise, the restriction becomes smaller and the cushion's effectiveness is increased. Tighten the lock nut securely after adjustment is performed.

2. **Do not use the cushion needle fully closed.**

This will cause damage to the seals.

⚠ Warning

1. **Use clean air.**

Do not use compressed air which includes chemicals, synthetic oils containing organic solvents, salt or corrosive gases, etc., as it can cause damage or malfunction.

⚠ Caution

1. **Install air filters.**

Install air filters at the upstream side of valves. The filtration degree should be 5 μ m or finer.

2. **Install an after cooler, air dryer or water separator, etc.**

Air that includes excessive drainage may cause malfunction of valves and other pneumatic equipment. To prevent this, install an after cooler, air dryer or water separator, etc.

3. **Use the product within the specified range of fluid and ambient temperature.**

Take measures to prevent freezing, since moisture in circuits can be frozen under 5°C, and this may cause damage to seals and lead to malfunction.

Refer to SMC's "Air Cleaning Equipment" catalog for further details on compressed air quality.

Maintenance

⚠ Warning

1. **Removal of equipment, and supply/exhaust of compressed air.**

Before any machinery or equipment is removed, first ensure that the appropriate measures are in place to prevent the fall or erratic movement of driven objects and equipment, then cut off the electric power and reduce the pressure in the system to zero. Only then should you proceed with the removal of any machinery and equipment.

When machinery is restarted, proceed with caution after confirming measures to prevent cylinder lurching.

⚠ Caution

1. **Drain flushing**

Remove drainage from air filters regularly. (Refer to specifications.)

Series NCA1

Auto Switch Precautions 1

Be sure to read before handling.

Design & Selection

⚠ Warning

1. Confirm the specifications.

Read the specifications carefully and use this product appropriately. The product may be damaged or malfunction if it is used outside the range of specifications for current load, voltage, temperature or impact.

2. Take precautions when multiple cylinders are used close together.

When multiple auto switch cylinders are used in close proximity, magnetic field interference may cause the switches to malfunction. Maintain a minimum cylinder separation of 40mm.

3. Pay attention to the length of time that a switch is ON at an intermediate stroke position.

When an auto switch is placed at an intermediate position of the stroke and a load is driven at the time the piston passes, the auto switch will operate, but if the speed is too great the operating time will be shortened and the load may not operate properly. The maximum detectable piston speed is:

$$V \text{ (mm/s)} = \frac{\text{Auto switch operating range (mm)} \times 1000}{\text{Time load applied (ms)}}$$

4. Keep wiring as short as possible.

<Reed switches>

As the length of the wiring to a load gets longer, the rush current at switching ON becomes greater, and this may shorten the product's life. (The switch will stay ON all the time.)

Use a contact protection box when the wire length is 5m or longer.

<Solid state switches>

Although wire length should not affect switch function, use a wire 100m or shorter.

5. Pay attention to the internal voltage drop of the switch.

<Reed switches>

1) Switches with an indicator light (Except D-Z76)

- If auto switches are connected in series as shown below, take note that there will be a large voltage drop because of internal resistance in the light emitting diodes. (Refer to internal voltage drop in the auto switch specifications.)

[The voltage drop will be "n" times larger when "n" auto switches are connected.]

Even though an auto switch operates normally, the load may not operate.



⚠ Warning

- In the same way, when operating under a specified voltage, although an auto switch may operate normally, the load may not operate. Therefore, the formula below should be satisfied after confirming the minimum operating voltage of the load.

$$\text{Supply voltage} - \text{Internal voltage drop of switch} > \text{Minimum operating voltage of load}$$

2) If the internal resistance of a light emitting diode causes a problem, select a switch without an indicator light (Model D-Z80).

<Solid state switches>

3) Generally, the internal voltage drop will be greater with a 2 wire solid state auto switch than with a reed switch. Take the same precautions as in 1).

Also, note that a 12VDC relay is not applicable.

6. Pay attention to leakage current.

<Solid state switches>

With a 2 wire solid state auto switch, current (leakage current) flows to the load to operate the internal circuit even when in the OFF state.

$$\text{Operating current of load (OFF condition)} > \text{Leakage current}$$

If the criteria given in the above formula are not met, it will not reset correctly (stays ON). Use a 3 wire switch if this specification will not be satisfied.

Moreover, leakage current flow to the load will be "n" times larger when "n" auto switches are connected in parallel.

7. Do not use a load that generates surge voltage.

<Reed switches>

If driving a load such as a relay that generates a surge voltage, use a contact protection box.

<Solid state switches>

Although a zener diode for surge protection is connected at the output side of a solid state auto switch, damage may still occur if the surge is applied repeatedly. When a load, such as a relay or solenoid which generates surge is directly driven, use a type of switch with a built-in surge absorbing element.

8. Cautions for use in an interlock circuit

When an auto switch is used for an interlock signal requiring high reliability, devise a double interlock system to avoid trouble by providing a mechanical protection function, or by also using another switch (sensor) together with the auto switch.

Also perform periodic maintenance and confirm proper operation.

9. Ensure sufficient clearance for maintenance activities.

When designing an application, be sure to allow sufficient clearance for maintenance and inspections.

Series NCA1

Auto Switch Precautions 2

Be sure to read before handling.

Mounting & Adjustment

⚠ Warning

1. Do not drop or bump.

Do not drop, bump or apply excessive impacts (300m/s² or more for reed switches and 1000m/s² or more for solid state switches) while handling. Although the body of the switch may not be damaged, the inside of the switch could be damaged and cause a malfunction.

2. Do not carry a cylinder by the auto switch lead wires.

Never carry a cylinder by its lead wires. This may not only cause broken lead wires, but it may cause internal elements of the switch to be damaged by the stress.

3. Mount switches using the proper tightening torque.

If a switch is tightened beyond the range of tightening torque, the mounting screws or switch may be damaged.

On the other hand, tightening below the range of tightening torque may allow the switch to slip out of position. (Refer to switch mounting instructions for each series for switch mounting, moving, and tightening torque, etc.)

4. Mount a switch at the center of the operating range.

Adjust the mounting position of an auto switch so that the piston stops at the center of the operating range (the range in which a switch is ON). (The mounting position shown in the catalog indicates the optimum position at stroke end.) If mounted at the end of the operating range (around the borderline of ON and OFF), operation will be unstable.

Wiring

⚠ Warning

1. Avoid repeatedly bending or stretching lead wires.

Broken lead wires will result from repeatedly applying bending stress or stretching force to the lead wires.

2. Be sure to connect the load before power is applied.

<2 wire type>

If the power is turned ON when an auto switch is not connected to a load, the switch will be instantly damaged because of excess current.

3. Confirm proper insulation of wiring.

Be certain that there is no faulty wiring insulation (contact with other circuits, ground fault, improper insulation between terminals, etc.). Damage may occur due to excess current flow into a switch.

4. Do not wire with power lines or high voltage lines.

Wire separately from power lines or high voltage lines, avoiding parallel wiring or wiring in the same conduit with these lines. Control circuits containing auto switches may malfunction due to noise from these other lines.

Wiring

⚠ Warning

5. Do not allow short circuit of loads.

<Reed switches>

If the power is turned ON with a load in a short circuited condition, the switch will be instantly damaged because of excess current flow into the switch.

<Solid state switches>

All models of PNP output type switches do not have built-in short circuit protection circuits.

Note that if a load is short circuited, the switch will be instantly damaged as in the case of reed switches.

*Take special care to avoid reverse wiring with the brown (red) power supply line and the black (white) output line on 3 wire type switches.

6. Avoid incorrect wiring.

<Reed switches>

A 24VDC switch with indicator light has polarity. The brown (red) lead wire is (+), and the blue (black) lead wire is (-).

1) If connections are reversed, a switch will operate, however, the light emitting diode will not light up.

Also note that a current greater than that specified will damage a light emitting diode and it will no longer operate.

Applicable models: D-Z73

<Solid state switches>

1) If connections are reversed on a 2 wire type switch, the switch will not be damaged if protected by a protection circuit, but the switch will always stay in an ON state. However, it is still necessary to avoid reversed connections, since the switch could be damaged by a load short circuit in this condition.

*2) If connections are reversed (power supply line + and power supply line -) on a 3 wire type switch, the switch will be protected by a protection circuit. However, if the power supply line (+) is connected to the blue (black) wire and the power supply line (-) is connected to the black (white) wire, the switch will be damaged.

* Lead wire color changes

Lead wire colors of SMC switches and related products have been changed in order to meet NECA (Nippon Electric Control Equipment Industries Association) Standard 0402 for production beginning September, 1996 and thereafter. Please refer to the tables provided.

Special care should be taken regarding wire polarity during the time that the old colors still coexist with the new colors.

2 wire

	Old	New
Output (+)	Red	Brown
Output (-)	Black	Blue

3 wire

	Old	New
Power supply	Red	Brown
GND	Black	Blue
Output	White	Black

Solid state with diagnostic output

	Old	New
Power supply	Red	Brown
GND	Black	Blue
Output	White	Black
Diagnostic output	Yellow	Orange

Solid state with latch type diagnostic output

	Old	New
Power supply	Red	Brown
GND	Black	Blue
Output	White	Black
Latch type diagnostic output	Yellow	Orange

Series NCA1

Auto Switch Precautions 3

Be sure to read before handling.

Operating Environment

Warning

1. Never use in an atmosphere of explosive gases.

The structure of auto switches is not intended to prevent explosion. Never use in an atmosphere with an explosive gas since this may cause a serious explosion.

2. Do not use in an area where a magnetic field is generated.

Auto switches will malfunction or magnets inside cylinders will become demagnetized. (Consult SMC regarding the availability of a magnetic field resistant auto switch.)

3. Do not use in an environment where the auto switch will be continually exposed to water.

Although switches satisfy IEC standard IP67 construction (JIS C 0920: watertight structure), do not use switches in applications where continually exposed to water splash or spray. Poor insulation or swelling of the potting resin inside switches may cause malfunction.

4. Do not use in an environment with oil or chemicals.

Consult SMC if auto switches will be used in an environment with coolant, cleaning solvent, various oils or chemicals. If auto switches are used under these conditions for even a short time, they may be adversely affected by improper insulation, malfunction due to swelling of the potting resin, or hardening of the lead wires.

5. Do not use in an environment with temperature cycles.

Consult SMC if switches are used where there are temperature cycles other than normal temperature changes, as there may be adverse effects inside the switches.

6. Do not use in an environment where there is excessive impact shock.

<Reed switches>

When excessive impact (300m/s² or more) is applied to a reed switch during operation, the contact point will malfunction and generate or cut off a signal momentarily (1ms or less). Consult SMC regarding the need to use a solid state switch depending upon the environment.

7. Do not use in an area where surges are generated.

<Solid state switches>

When there are units (solenoid type lifter, high frequency induction furnace, motor, etc.) which generate a large amount of surge in the area around cylinders with solid state auto switches, this may cause deterioration or damage to the switch. Avoid sources of surge generation and disorganized lines.

8. Avoid accumulation of iron waste or close contact with magnetic substances.

When a large amount of iron waste such as machining chips or spatter is accumulated, or a magnetic substance (something attracted by a magnet) is brought into close proximity with an auto switch cylinder, it may cause the auto switch to malfunction due to a loss of the magnetic force inside the cylinder.

Maintenance

Warning

1. Perform the following maintenance periodically in order to prevent possible danger due to unexpected auto switch malfunction.

1) Secure and tighten switch mounting screws.

If screws become loose or the mounting position is dislocated, retighten them after readjusting the mounting position.

2) Confirm that there is no damage to lead wires.

To prevent faulty insulation, replace switches or repair lead wires, etc., if damage is discovered.

3) Confirm the lighting of the green light on the 2 color indicator type switch.

Confirm that the green LED is on when stopped at the established position. If the red LED is on, the mounting position is not appropriate. Readjust the mounting position until the green LED lights up.

Other

Warning

1. Consult SMC concerning water resistance, elasticity of lead wires, and usage at welding sites, etc.

Limited Cylinder Warranty - Terms and Conditions of Sale....

SMC warrants that for **18 months or 1800 service miles***, whichever occurs first from date of purchase, it will replace or make adjustment at SMC's option, of any defective cylinder sold if the cylinder product is returned with SMC's prior written consent, transportation prepaid by the original buyer, and received by SMC at its place of business within the warranty period.

SMC shall have the right to inspect, prior to return, at the buyer's facility, any products claimed to be defective.

This warranty is limited exclusively to cylinder products which, in the opinion of SMC, have not been subjected to modification, misuse, negligence, misapplication, repairs or alterations. Damage caused by fire, theft, riot, explosion or acts of Gods are excluded

from this warranty. The foregoing constitutes the sole exclusive remedy of the buyer and the only liability of SMC and is in lieu of any and all other warranties, expressed or implied, or statutory as to merchantability, fitness for purpose sold, description, quality, productiveness or any other matter. SMC shall not be liable for loss of use, or profit, or special or consequential damages.

SMC assumes no responsibility for engineering technical advice pertaining to any manufactured item to which SMC's products or goods have been attached. No agent, employee, distributor, or representative of SMC has the authority to extend the scope of this warranty or to make any other promises, warranties or guarantees concerning the manufacture, sale or application of SMC's products.

**Service Miles = (inches/stroke) x (2 strokes/cycle) x (no of cycles) x [1 mile / 63,360 inches]*

Global Manufacturing, Distribution and Service Network

Worldwide Subsidiaries

EUROPE

AUSTRIA
SMC Pneumatik GmbH (Austria)

BELGIUM
SMC Pneumatics N.V./S.A.

BULGARIA
SMC Industrial Automation Bulgaria EOOD

CROATIA
SMC Industrijska Automatika d.o.o.

CZECH
SMC Industrial Automation CZ s.r.o.

DENMARK
SMC Pneumatik A/S

ESTONIA
SMC Pneumatics Estonia

FINLAND
SMC Pneumatics Finland OY

FRANCE
SMC Pneumatique S.A.

GERMANY
SMC Pneumatik GmbH

GREEK
SMC Hellas EPE

HUNGARY
SMC Hungary Ipari Automatizálási Kft.

IRELAND
SMC Pneumatics (Ireland) Ltd.

ITALY
SMC Italia S.p.A.

LATVIA
SMC Pneumatics Latvia SIA

LIETUVA
SMC Pneumatics Lietuva, UAB

NETHERLANDS
SMC Pneumatics BV

NORWAY
SMC Pneumatics Norway A/S

POLAND
SMC Industrial Automation Polska Sp.z.o.o.

ROMANIA
SMC Romania S.r.l.

RUSSIA
SMC Pneumatik LLC.

SLOVAKIA
SMC Priemyselná Automatizácia, s.r.o.

SLOVENIA
SMC Industrijska Avtomatika d.o.o.

SPAIN/PORTUGAL
SMC España, S.A.

SWEDEN
SMC Pneumatics Sweden AB

SWITZERLAND
SMC Pneumatik AG

UK
SMC Pneumatics (U.K.) Ltd.

ASIA

CHINA
SMC (China) Co., Ltd.

HONG KONG
SMC Pneumatics (Hong kong) Ltd.

INDIA
SMC Pneumatics (India) Pvt. Ltd.

JAPAN
SMC Corporation

MALAYSIA
SMC Pneumatics (S.E.A.) Sdn. Bhd.

PHILIPPINES
SMC Pneumatics (Philippines), Inc.

SINGAPORE
SMC Pneumatics (S.E.A.) Pte. Ltd.

SOUTH KOREA
SMC Pneumatics Korea Co., Ltd.

TAIWAN
SMC Pneumatics (Taiwan) Co., Ltd.

THAILAND
SMC Thailand Ltd.

NORTH AMERICA

CANADA
SMC Pneumatics (Canada) Ltd.

MEXICO
SMC Corporation (Mexico) S.A. DE C.V.

USA
SMC Corporation of America

SOUTH AMERICA

ARGENTINA
SMC Argentina S.A.

BOLIVIA
SMC Pneumatics Bolivia S.R.L.

BRAZIL
SMC Neumaticos do Brazil Ltda.

CHILE
SMC Pneumatics (Chile) S.A.

VENEZUELA
SMC Neumatica Venezuela S.A.

OCEANIA

AUSTRALIA
SMC Pneumatics (Australia) Pty. Ltd.

NEW ZEALAND
SMC Pneumatics (N.Z.) Ltd.

U.S. & Canadian Sales Offices

EAST

Atlanta
Boston
Charlotte
Nashville
New Jersey
Richmond
Rochester
Tampa

WEST

Austin
Dallas
Los Angeles
Phoenix
Portland
San Francisco

MIDWEST

Chicago
Cincinnati
Cleveland
Detroit
Indianapolis
Milwaukee
Minneapolis
St. Louis

CANADA

Montreal
Tel: (514) 733-9595
Fax: (514) 733-1771

Toronto
Tel: (905) 812-0400
Fax: (905) 812-8686

Vancouver
Tel: (604) 517-1646
Fax: (604) 517-1647

Windsor
Tel: (519) 944-0555
Fax: (519) 944-1870

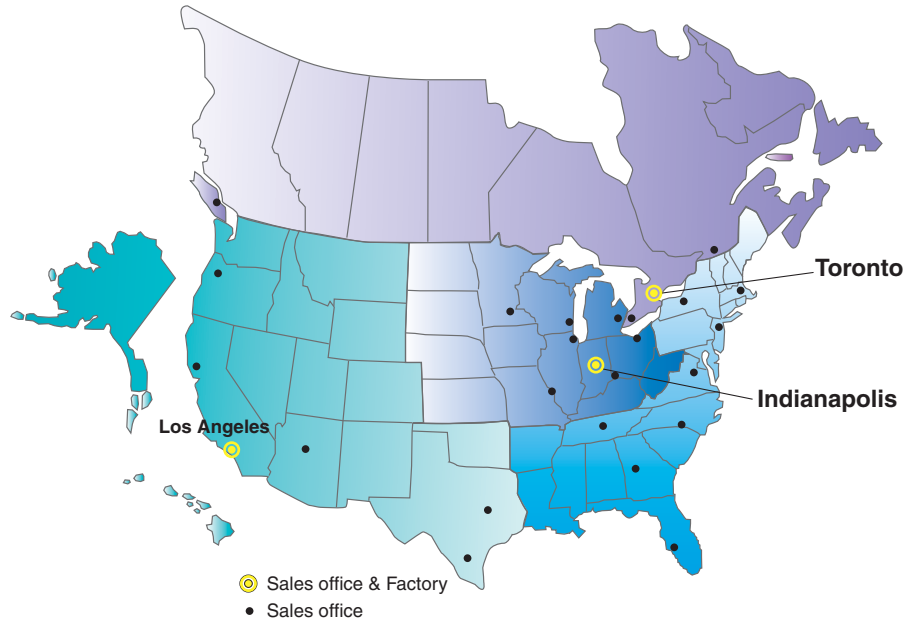

SMC Corporation of America
3011 N. Franklin Road
Indianapolis, IN 46226

SMC Pneumatics (Canada) Ltd.
6768 Financial Drive Mississauga
Ontario, L5N 7J6 Canada

(800) 762-7621 (SMC.SMC1)
www.smcusa.com
For International inquires: www.smcworld.com

(905) 812-0400
www.smc Pneumatics.ca





Series *NCA1*

**Air Cylinder NFPA Interchangeable
Large Bore Size**

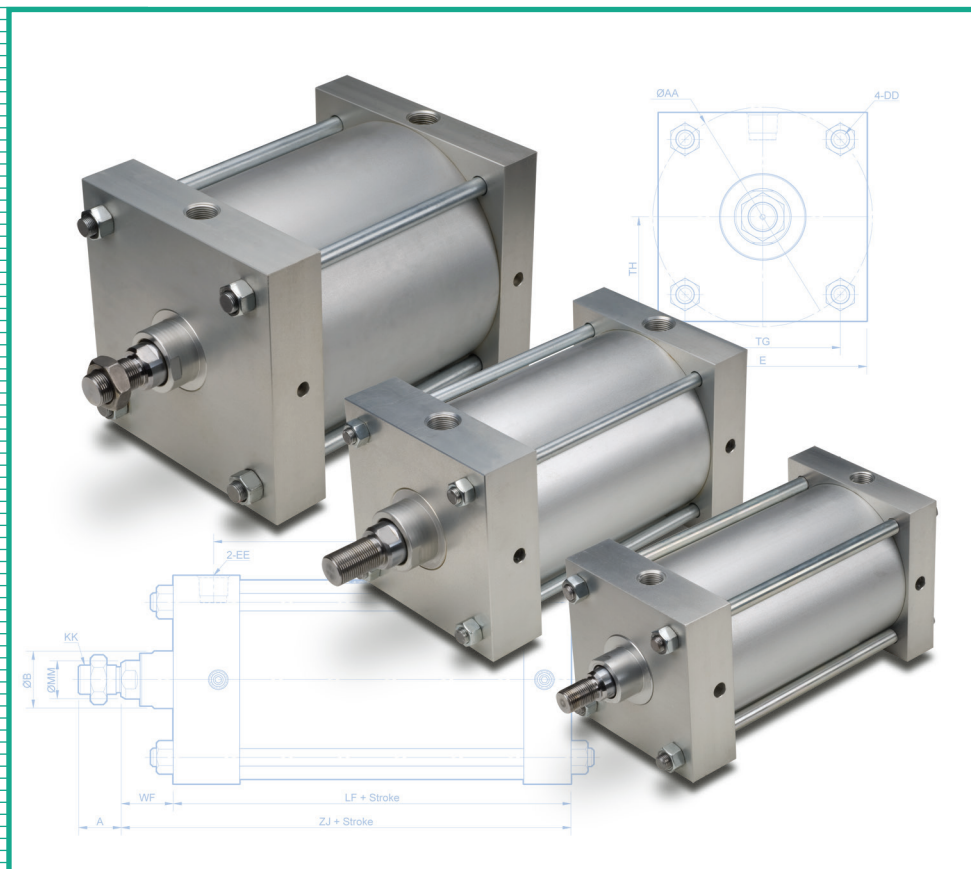

Features

- Medium duty 5", 6" and 8" bores
- 11 different NFPA mounting options
- Standard with adjustable air cushion
- Auto switch capable

Contents

	page
How to order	3
Auto Switches	3
Specifications	4
Construction	5
Replacement Kits	5
 Mounting styles	
B MX0 basic style	6
BA MX1 tie rod extended - both ends	6
BB MX2 tie rod extended - head end	7
BC MX3 tie rod extended - rod cover end	7
F MF1 rod side rectangular flange	8
G MF2 head side rectangular flange	8
L MS1 foot style	9
R MS2 side tapped style	9
S MS4 side lug style	10
X MP1 double head clevis style	10
D MP2 double detachable head side clevis style	11
Dimension Changes (XB5, XC3 Options)	11
Accessories	12
Warranty and Precautions	14

How to Order

NC **D** A1 **B** **500** - **04** **00** - **XB5**

Built in magnet

Nil	None
D	Auto switch capable (magnetic option)

Bore size

500	5"
600	6"
800	8"

Option

Nil	No option
XB5	Oversized rod
XB6	High temperature
XB7	Low temperature
XC3	Rotated ports *
XC6	Stainless steel piston rod
XC35	With coil scraper

Mounting style

B	MX0	Basic style
BA	MX1	Tie rod extended - both ends
BB	MX2	Tie rod extended - head end
BC	MX3	Tie rod extended - rod cover end
F*	MF1	Rod side rectangular flange
G*	MF2	Head side rectangular flange
L	MS1	Foot style
S	MS2	Side lug style
R	MS4	Side tapped style
X	MP1	Double head clevis style
D	MP2	Double detachable head side clevis style

Standard stroke

Inches

Stroke

Hundredths of an inch

Air Cushion

Nil	Both ends
N	None
H	Head end
R	Rod end

* Refer to page 11 for order details.

Notes:

- Low temperature option does not include air cushions. When using this option, specify "N" in part number for air cushion.
- Auto switch capable not available with options XB6 & XB7
- High temperature option for bore 6" and 8" does not include air cushions. When using this option, specify "N" in part number for air cushion.
- External cushioning recommended for cylinder without standard air cushioning. (Refer to kinetic energy absorption warning)
- Limit of two X-options per standard model. XB6 and XB7 can not be combined.

* Not available on 8" bore

Auto switches

Type	Special function	Indicator light	Wiring (output)	Load voltage		Auto switch model	Lead wire length (m)				Pre-wired Connector	Applicable load		
				DC	AC		0.5 (Nil)	1 (M)	3 (L)	5 (Z)				
Solid state switch	-	-	3 wire (NPN)	24 V	5 V	M9N	●	●	●	○	○	IC circuit	Relay, PLC	
			3 wire (PNP)	-	12 V	M9P	●	●	●	○	○			
			2 Wire	-	12 V	M9B	●	●	●	○	○			
			3 wire (NPN)	5 V	-	M9NW	●	●	●	○	○			
	Diagnostic indication (2-color indication)	Yes	-	3 wire (PNP)	12 V	-	M9PW	●	●	●	○	○		IC circuit
				2 Wire	24 V	12 V	M9BW	●	●	●	○	○		-
				3 wire (NPN)	5 V	-	M9NA	○	○	●	○	○		IC circuit
				3 wire (PNP)	12 V	-	M9PA	○	○	●	○	○		IC circuit
Water Resistant (2-color indication)	-	-	2 Wire	12 V	-	M9BA	○	○	●	○	○	-		
			3 wire (NPN)	24 V	5 V	-	M9A	○	○	●	○	○	IC circuit	
Reed switch	-	-	3 Wire (NPN equivalent)	-	5 V	A96	●	-	●	-	-	IC circuit	-	
			Yes	2 Wire	24 V	5 V	100 V	A93	●	-	●	-	-	Relay, PLC
			No	2 Wire	24 V	5 V	100 V or less	A90	●	-	●	-	-	IC circuit

* With pre-wired connector is available for solid state autoswitches. For details, refer to Best Pneumatics No. 2

Operating Range

Auto switch model	Bore size		
	Ø5	Ø6	Ø8
D-A9□/A9□V	12	12.5	11.5
D-M9□/M9□V	6	6.5	6.5
D-M9□W/M9□WV			
D-M9□AL/M9□AVL			

* Since this is a guideline including hysteresis, it is not meant to be guaranteed. (Assuming approximately ±30% dispersion.) In some cases it may vary substantially depending on the ambient environment.

Switch Mounting Bracket Part No.

Auto switch model	Bore size (in)		
	Ø5	Ø6	Ø8
D-A9□/A9□V	BS5-125	BS5-125	BS5-160
D-M9□/M9□V			
D-M9□W/M9□WV			
D-M9□AL/M9□AVL			

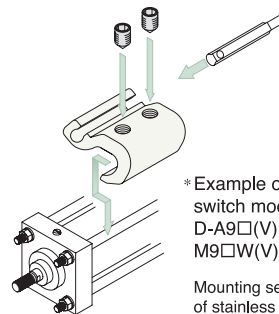

* Example of mounting switch models: D-A9□(V), M9□(V), M9□W(V), M9□A(V)L
Mounting set screws made of stainless steel

Series NCA1 Cylinder

Large Bore

Specifications

Type	Double acting, single rod
Fluid	Air
Lubrication	Non-lube
Minimum operating pressure	8 psi (0.06 Mpa)
Maximum operating pressure	250 psi (1.75 Mpa)
Ambient and Fluid Temperature	40 - 140°F (5 - 60°C)
Piston speed	2 ~ 20 in/sec (50 ~ 500mm/sec)
Cushion	Standard, both ends
Maximum stroke	36 in
Industry specification	ANSI/(NFPA) T3.6.7 R3

Kinetic Energy Absorbed

Bore size	Effective Cushion Length (in)	Absorbable Kinetic Energy (ft-lb)
Ø5"	0.85	23.49
Ø6"	1.06	38.48
Ø8"	1.03	65.25

Warning

A deceleration circuit or shock absorber may be required. When a driven object is operated at high speed or the load is heavy, a cylinder's cushion will not be sufficient to absorb the shock. Install a deceleration circuit to reduce the speed before cushioning, or install an external shock absorber to relieve the shock. In this case, the rigidity of the machinery should also be examined.

Weight / Aluminum Tube

Bore Size (inch)		500 (5")	600 (6")	800 (8")
Basic weight	B/R - basic type (MX0/MS4)	13.41	21.38	36.57
	BA/BB - Tie rod extended - either end (MX1/MX2)	13.65	21.63	37.25
	BC - Tie rod extended - both ends (MX3)	13.89	21.86	37.75
	F/G - Flange Mounting (MF1/MF2)	19.63	31.57	N/A
	L - Foot mounting (MS1)	16.66	25.55	41.64
	S - Side lug (MS2)	15.41	23.76	40.21
	X - Clevis mounting (MP1)	18.05	30.65	52.74
	D - Double detachable head side clevis	18.73	29.58	54.73
	Additional weight for magnet (NCDA1)	0.04	0.05	0.06
	Additional weight for oversize rod (XB5)	0.91	1.54	1.57
Additional weight per 2" stroke	Standard piston rod	1.22	1.61	2.30
	Oversize piston rod (XB5)	1.61	2.13	2.81

Calculation example: NCDA1B500-0600-XB5 (Basic mount, auto switch capable, Ø5" bore, 6" stroke, oversized rod)

basic weight	13.41 lb + 0.91 lb	=	14.32 lb
add auto switch magnet	0.036 lb	=	0.04 lb
additional weight based on stroke	1.61 lb (6"/2")	=	4.84 lb
			19.20 lb

Cylinder Bores and Forces: Push Stroke (Extend)



Operating Pressure (psi)		50	60	80	100	200	250
Bore Size	Piston Area	Force output (lbs)					
5"	19.63	982	1178	1571	1963	3927	4909
6"	28.27	1414	1696	2262	2827	5655	7069
8"	50.27	2513	3016	4021	5027	10053	12566

Cylinder Bores and Forces: Pull Stroke (Retract)



Operating Pressure (psi)		50	60	80	100	200	250
Bore Size	Piston Area	Force output (lbs)					
5"	18.85	942	1131	1508	1885	3770	4712
5" XB5	18.15	908	1089	1452	1815	3630	4538
6"	26.79	1339	1607	2143	2679	5358	6697
6" XB5	25.87	1293	1552	2070	2587	5174	6467
8"	48.78	2439	2927	3902	4878	9756	12195
8" XB5	47.86	2393	2872	3829	4786	9572	11965

Construction

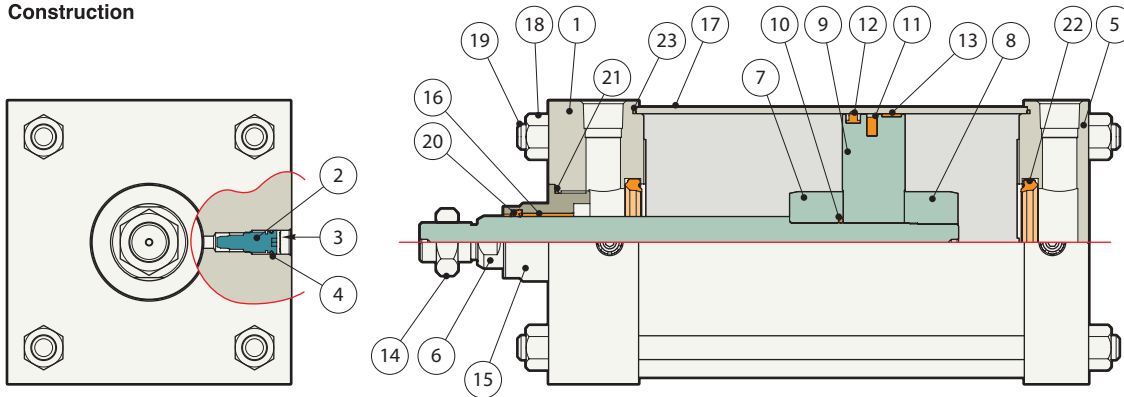

How to Order Seal Kits

NCA **500** - PS -

Bore	Special options
500	Nil Standard
600	XB5 Oversized rod
800	XB6 High temperature
	XB7 Low temperature
	XB5B6 Oversized W/ high temperature
	XB5B7 Oversized W/ low temperature

Seal kits include the following parts:

1 - Rod seal	2 - Cushion valve seal
1 - Piston seal	2 - Grease pack
1 - Gland seal	1 - Loctite 243
2 - Cylinder tube gasket	

* Cushion seal is not included for XB6, XB5B6, XB7, and XB5B7 over ø5" bore

How to Order Cylinder Tube - Double Acting, Single Rod

NCA **500** - 04 - **0400**

Bore	Stroke
500	(In inches and hundredths)
600	
800	

How to Order Gland Kits

NCA **500** - RG -

Bore	Special options	Gland kits Include:
500	Nil Standard	1 - Gland
600	XB5 Oversized rod	1 - Bushing
800	XC35 Coil scraper	* Scraper with XC35
	XB5C35 Oversized W/ Coil scraper	

How to Order Piston Rod Assembly - Double Acting, Single Rod

NC **D** **A** **500** - 26A - **0400** -

Magnet	Bore	Stroke	Special options
Nil - Non-Magnet	500	(In inches and hundredths)	Nil Standard
D - With Magnet	600		XB5 Oversized rod
	800		XB6 High temperature
			XB7 Low temperature
			XB5B6 Oversized W/ high temperature
			XB5B7 Oversized W/ low temperature
			XC3 Stainless steel piston rod

Component parts

Component	Material	Qty.	Note
1	Rod cover	Aluminum alloy	1 Anodized
2	Cushion valve	Rolled steel	2 Electroless nickel plating
3	Snap ring	Spring steel	2 Phosphate coated
4	Cushion valve seal	NBR	2
5	Head cover	Aluminum alloy	1 Anodized
6	Piston rod	Carbon steel	1
7	Cushion A	Aluminum alloy	1 Anodized
8	Cushion B	Aluminum alloy	1 Anodized
9	Piston	Aluminum alloy	1
10	Piston gasket	NBR	1
11	Magnet	-	(1)
12	Piston seal	NBR	1
13	Wear ring	Resin	1
14	Jam nut	Rolled steel	1 Nickel plating
15	Gland	Aluminum alloy	1 Anodized
16	Bushing	Composite	1
17	Cylinder tube	Aluminum alloy	1 Hard anodized
18	Tie rod nut	Rolled steel	8 Nickel plated
19	Tie rod	Carbon steel	4 Zinc chromated
20	Rod seal	NBR	1
21	Gland seal	NBR	1
22	Cushion seal	Urethane	2
23	Cylinder tube gasket	NBR	2

How to Order Tie Rods - Double Acting, Single Rod

NCA **B** **500** - 11 - **0400**

Mounting	Bore	Stroke
B L	500	(In inches and hundredths)
BA S	600	
BB R	800	
BC X		
F D		
G		

Note: Tie rod length varies by mounting style. Quantity one set (4 pcs) of tie rods by mounting

Series NCA1 Cylinder

Large Bore

Dimension Drawings

MX0 - Basic style (B)

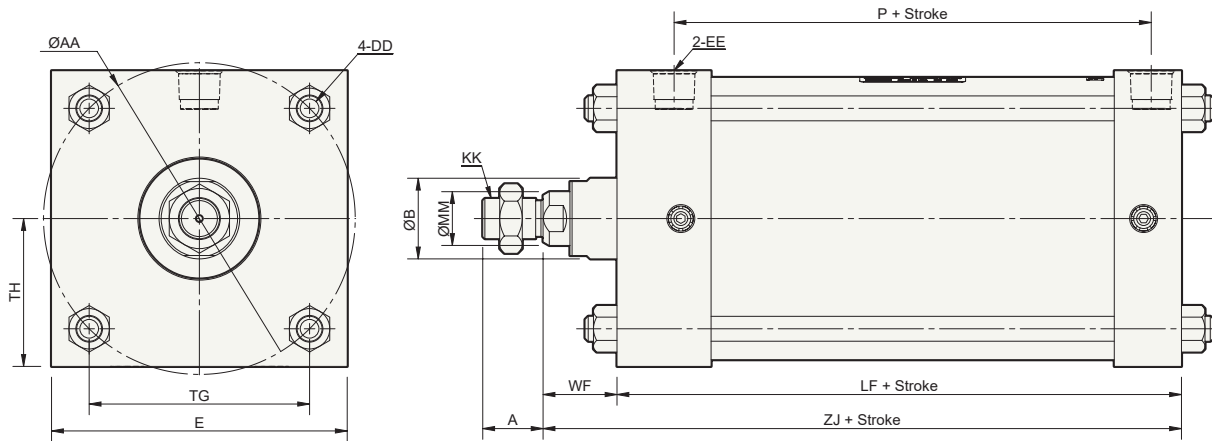

Bore Size (in)	ØMM	KK	A	AA	ØB	DD	E	EE	LF+	P+	TG	TH	WF	ZJ+
500 (5")	1.000	3/4-16	1.13	5.80	1.500	1/2-20	5.50	1/2NPT	4.50	2.88	4.10	2.75	1.38	5.88
600 (6")	1.375	1-14	1.63	6.90	2.000	1/2-20	6.50	3/4 NPT	5.00	3.13	4.88	3.25	1.63	6.63
800 (8")	1.375	1-14	1.63	9.10	2.000	5/8-18	8.50	3/4 NPT	5.13	3.25	6.44	4.25	1.63	6.75

MX1 - Tie rod extended - both ends (BA)

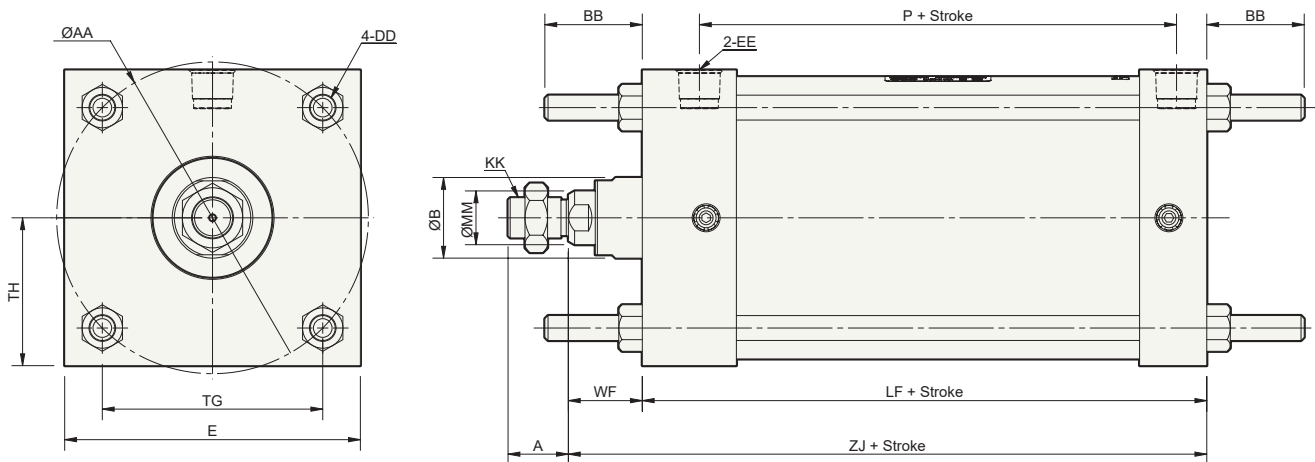

Bore Size (in)	ØMM	KK	A	AA	ØB	BB	DD	E	EE	LF+	P+	TG	TH	WF	ZJ+
500 (5")	1.000	3/4-16	1.13	5.80	1.500	1.81	1/2-20	5.50	1/2 NPT	4.50	2.88	4.10	2.75	1.38	5.88
600 (6")	1.375	1-14	1.63	6.90	2.000	1.81	1/2-20	6.50	3/4 NPT	5.00	3.13	4.88	3.25	1.63	6.63
800 (8")	1.375	1-14	1.63	9.10	2.000	2.31	5/8-18	8.50	3/4 NPT	5.13	3.25	6.44	4.25	1.63	6.75

MX2 - Tie rod extended - head end (BB)

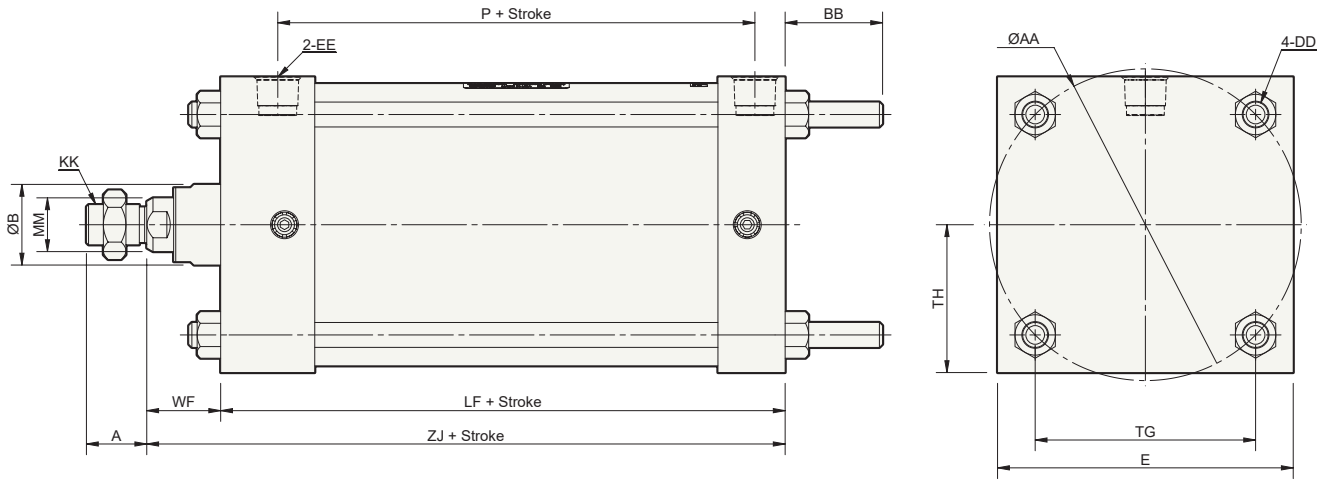

Bore Size (in)	ØMM	KK	A	AA	ØB	BB	DD	EE	E	LF+	P+	TG	TH	WF	ZJ+
500 (5")	1.000	3/4-16	1.13	5.80	1.500	1.81	1/2-20	1/2 NPT	5.50	4.50	2.88	4.10	2.75	1.38	5.88
600 (6")	1.375	1-14	1.63	6.90	2.000	1.81	1/2-20	3/4 NPT	6.50	5.00	3.13	4.88	3.25	1.63	6.63
800 (8")	1.375	1-14	1.63	9.10	2.000	2.31	5/8-18	3/4 NPT	8.50	5.13	3.25	6.44	4.25	1.63	6.75

MX3 - Tie rod extended - rod cover end (BC)

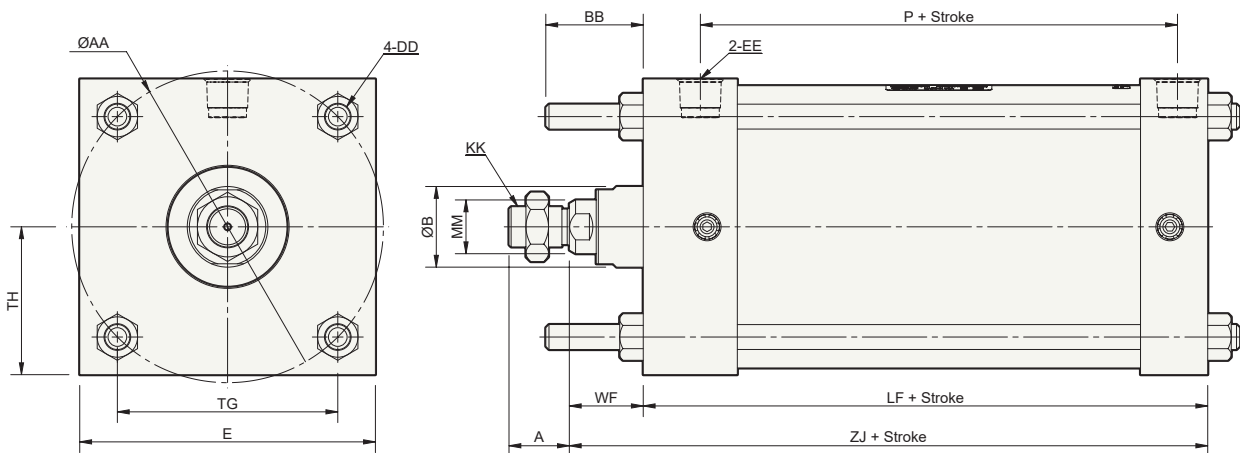

Bore Size (in)	ØMM	KK	A	AA	ØB	BB	DD	EE	E	LF+	P+	TG	TH	WF	ZJ+
500 (5")	1.000	3/4-16	1.13	5.80	1.500	1.81	1/2-20	1/2 NPT	5.50	4.50	2.88	4.10	2.75	1.38	5.88
600 (6")	1.375	1-14	1.63	6.90	2.000	1.81	1/2-20	3/4 NPT	6.50	5.00	3.13	4.88	3.25	1.63	6.63
800 (8")	1.375	1-14	1.63	9.10	2.000	2.31	5/8-18	3/4 NPT	8.50	5.13	3.25	6.44	4.25	1.63	6.75

Series NCA1 Cylinder

Large Bore

Dimension Drawings

MF1 - Rod side rectangular flange (F)

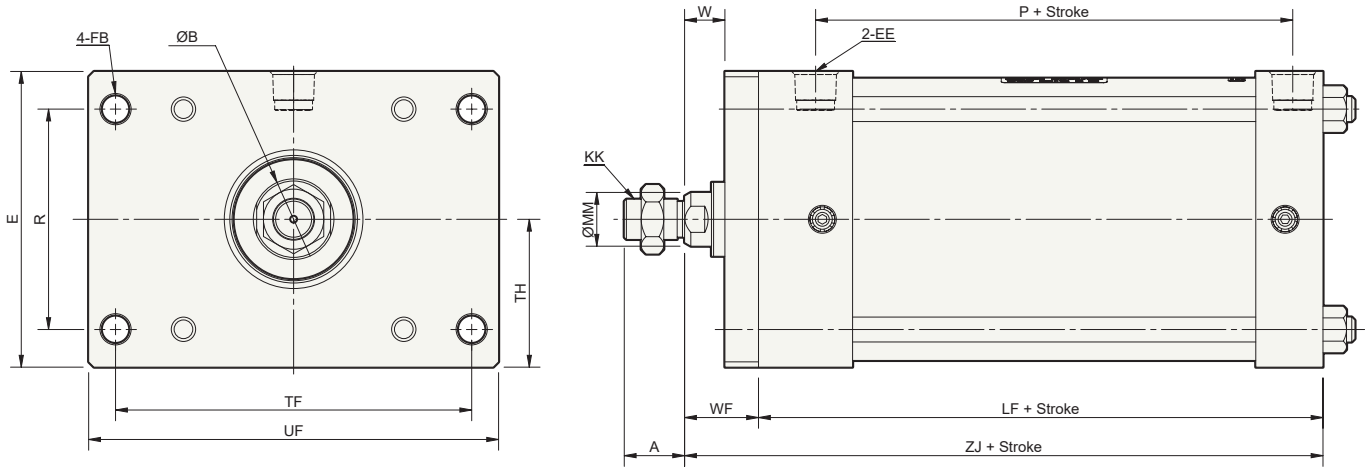

Bore Size (in)	ØMM	KK	A	ØB	E	EE	ØFB	LF+	P+	R	TF	TH	UF	W	WF	ZJ+
500 (5")	1.000	3/4-16	1.13	1.500	5.50	1/2 NPT	.50	4.50	2.88	4.10	6.63	2.75	7.63	.75	1.38	5.88
600 (6")	1.375	1-14	1.63	2.000	6.50	3/4 NPT	.50	5.00	3.13	4.88	7.63	3.25	8.63	.88	1.63	6.63

MF2 - Head side rectangular flange (G)

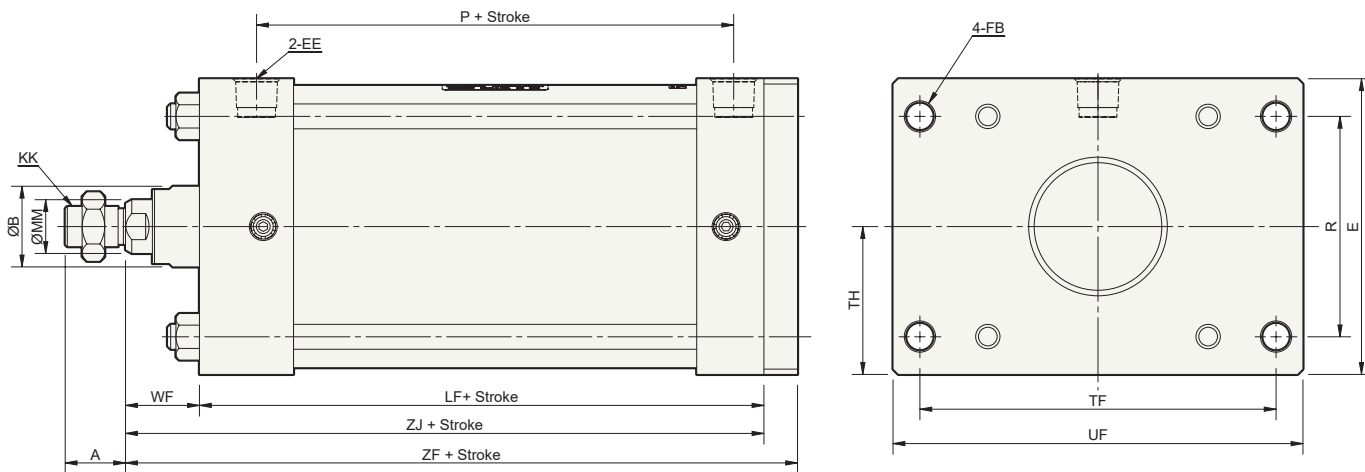

Bore Size (in)	ØMM	KK	A	ØB	E	EE	ØFB	LF+	P+	R	TF	TH	UF	WF	ZF+	ZJ+
500 (5")	1.000	3/4-16	1.13	1.500	5.50	1/2 NPT	.50	4.50	2.88	4.10	6.63	2.75	7.63	1.38	6.50	5.88
600 (6")	1.375	1-14	1.63	2.000	6.50	3/4 NPT	.50	5.00	3.13	4.88	7.63	3.25	8.63	1.63	7.38	6.63

MS1 - Foot style (L)

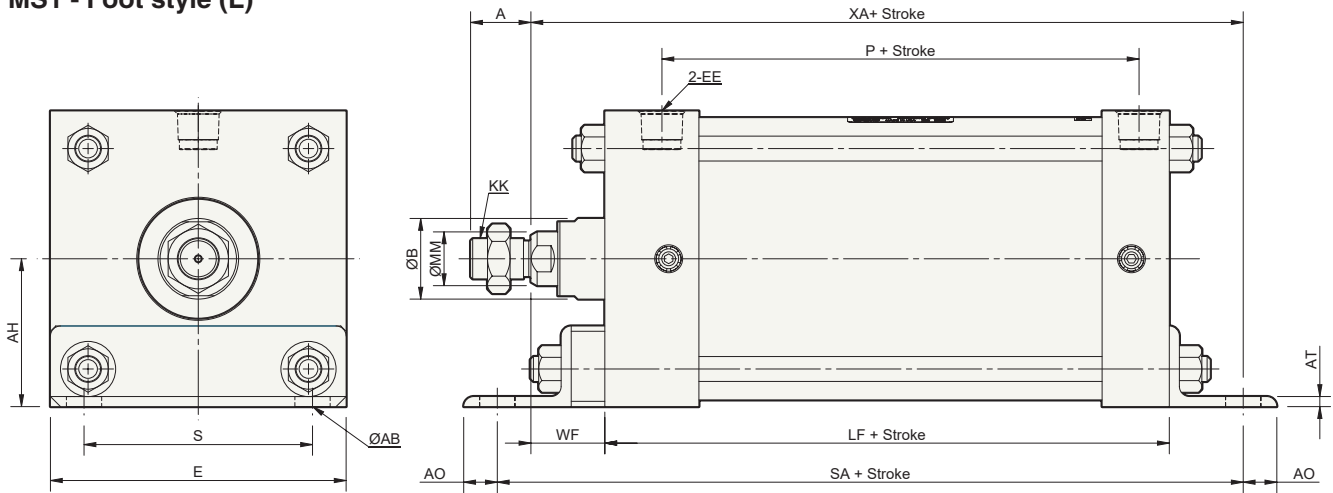

Bore Size (in)	ØMM	KK	A	ØAB	AH	AO	AT	ØB	E	EE	LF+	P+	S	SA+	WF	XA+
500 (5")	1.000	3/4-16	1.13	.63	2.75	.63	.19	1.500	5.50	1/2 NPT	4.50	2.88	4.25	7.88	1.38	7.25
600 (6")	1.375	1-14	1.63	.75	3.25	.63	.19	2.000	6.50	3/4 NPT	5.00	3.13	5.25	8.50	1.63	8.00
800 (8")	1.375	1-14	1.63	.75	4.25	.69	.25	2.000	8.50	3/4 NPT	5.13	3.25	7.13	8.75	1.63	8.56

MS2 - Side lug style (S)

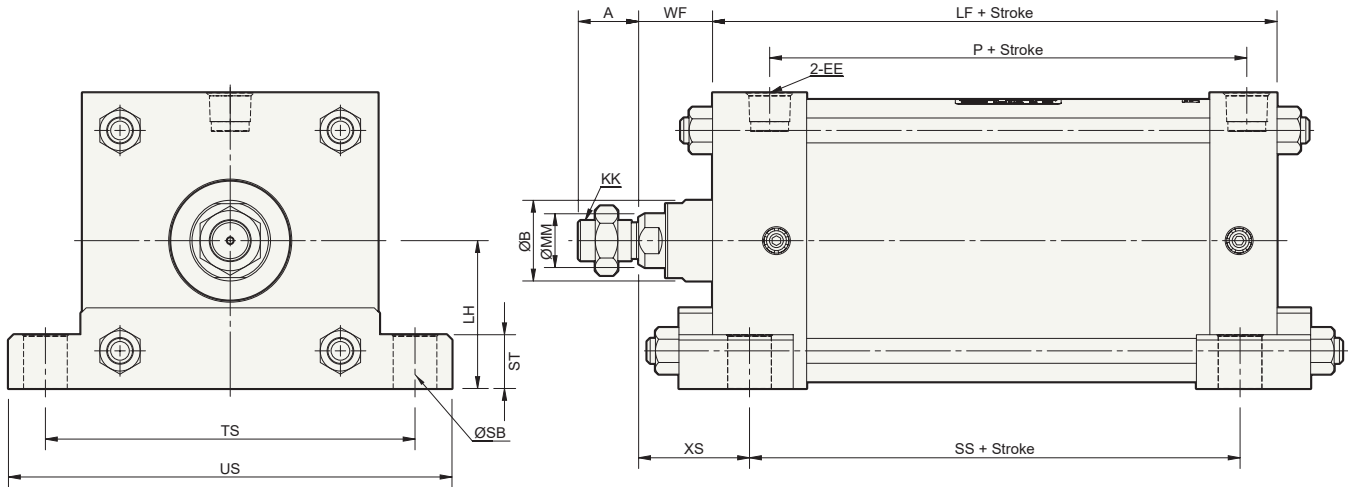

Bore Size (in)	ØMM	KK	TS	A	ØB	US	ST	EE	LF+	XS	SS+	P+	LH	WF	ØSB
500 (5")	1.000	3/4-16	6.88	1.13	1.500	8.25	1.00	1/2 NPT	4.50	2.06	3.13	2.88	2.75	1.38	0.75
600 (6")	1.375	1-14	7.88	1.63	2.000	9.25	1.00	3/4 NPT	5.00	2.31	3.63	3.13	3.25	1.63	0.75
800 (8")	1.375	1-14	9.88	1.63	2.000	11.25	1.00	3/4 NPT	5.13	2.31	3.75	3.25	4.25	1.63	0.75

Series NCA1 Cylinder

Large Bore

Dimension Drawings

MS4 - Side tapped style (R)

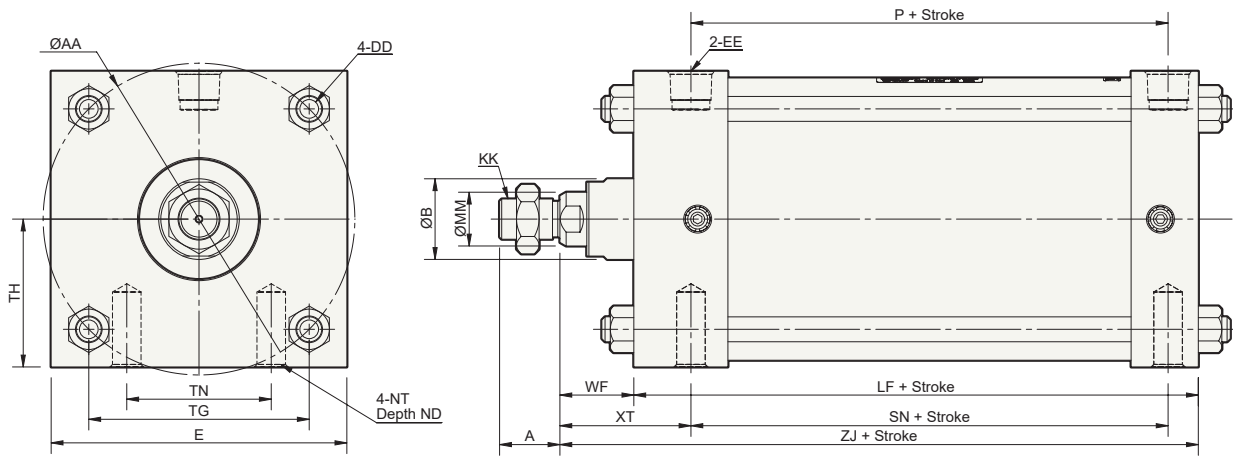

Bore Size (in)	ØMM	KK	A	AA	ØB	DD	E	EE	LF+	ND	NT	P+	SN+	TG	TH	TN	WF	XT	ZJ+
500 (5")	1.000	3/4-16	1.13	5.80	1.500	1/2-20	5.50	1/2NPT	4.50	.75	5/8-11	2.88	2.88	4.10	2.75	2.68	1.38	2.44	5.88
600 (6")	1.375	1-14	1.63	6.90	2.000	1/2-20	6.50	3/4NPT	5.00	.88	3/4-10	3.13	3.13	4.88	3.25	3.25	1.63	2.81	6.63
800 (8")	1.375	1-14	1.63	9.10	2.000	5/8-18	8.50	3/4NPT	5.13	1.13	3/4-10	3.25	3.25	6.44	4.25	4.50	1.63	2.81	6.75

MP1 - Double head clevis style (X)

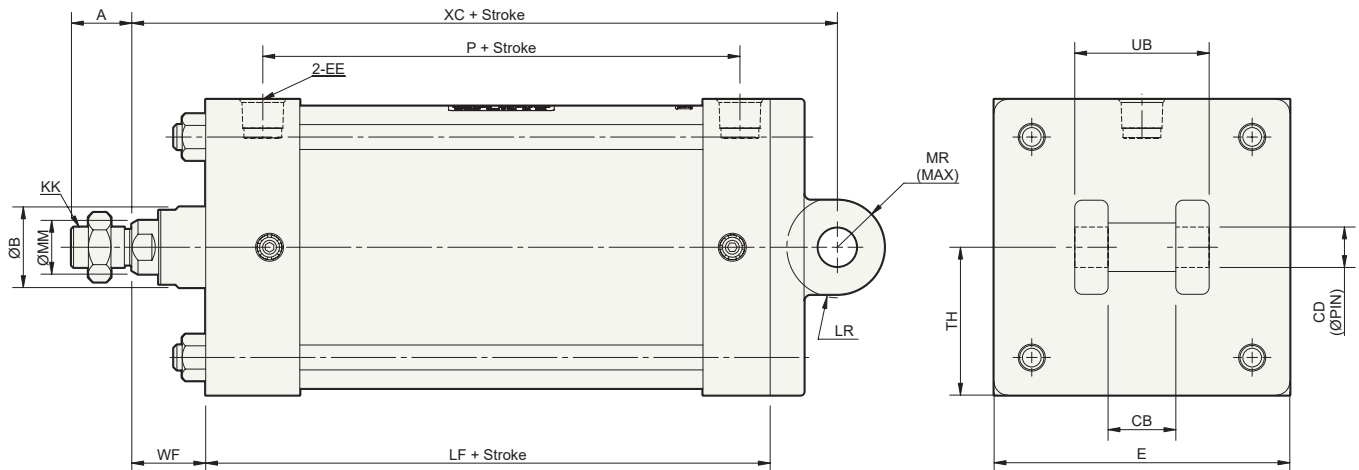

Bore Size (in)	ØMM	KK	A	ØB	CB	CD	E	EE	LF+	LR	MR	P+	TH	UB	WF	XC+
500 (5")	1.000	3/4-16	1.13	1.500	1.280	.750	5.50	1/2 NPT	4.50	.94	.95	2.88	2.75	2.500	1.38	7.13
600 (6")	1.375	1-14	1.63	2.000	1.530	1.000	6.50	3/4 NPT	5.00	1.31	1.32	3.13	3.25	3.000	1.63	8.13
800 (8")	1.375	1-14	1.63	2.000	1.530	1.000	8.50	3/4 NPT	5.13	1.31	1.32	3.25	4.25	3.000	1.63	8.25

Note: Pivot and cotter pins are included.

MP2 - Double detachable head side clevis style (D)

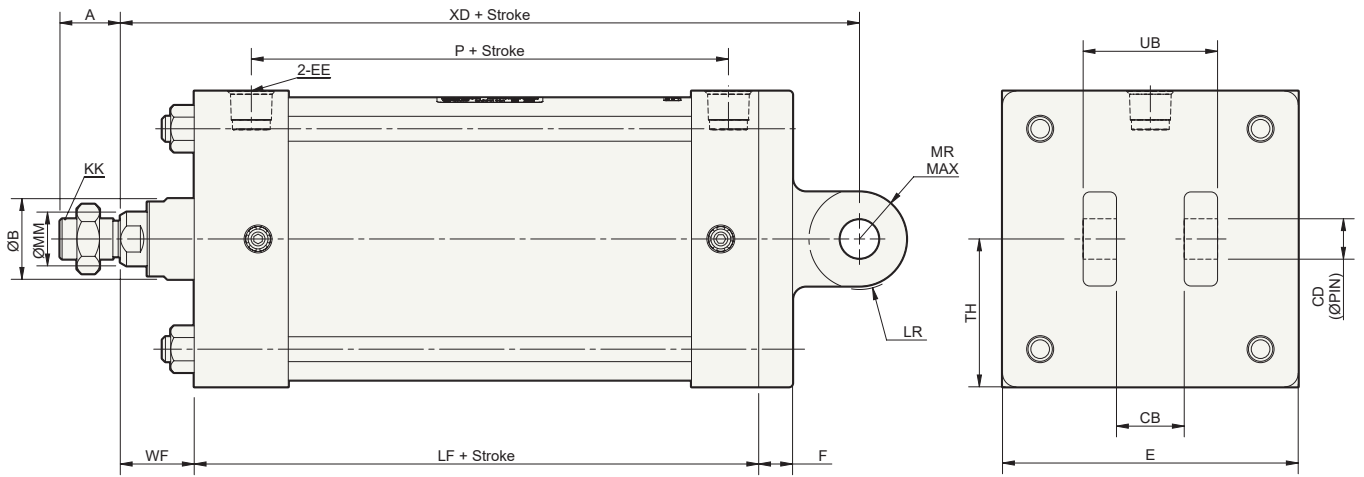

Bore Size (in)	ØMM	KK	A	ØB	CB	CD	E	EE	F	LF+	LR	MR	P+	TH	UB	WF	XD+
500 (5")	1.000	3/4-16	1.13	1.500	1.280	.750	5.50	1/2 NPT	.63	4.50	.94	.95	2.88	2.75	2.500	1.38	7.75
600 (6")	1.375	1-14	1.63	2.000	1.530	1.000	6.50	3/4 NPT	.75	5.00	1.31	1.32	3.13	3.25	3.000	1.63	8.88
800 (8")	1.375	1-14	1.63	2.000	1.530	1.000	8.50	3/4 NPT	.75	5.13	1.31	1.32	3.25	4.25	3.000	1.63	9.00

Note: Pivot and cotter pins are included.

Dimension changes for Options

Oversized rod (XB5 Option)

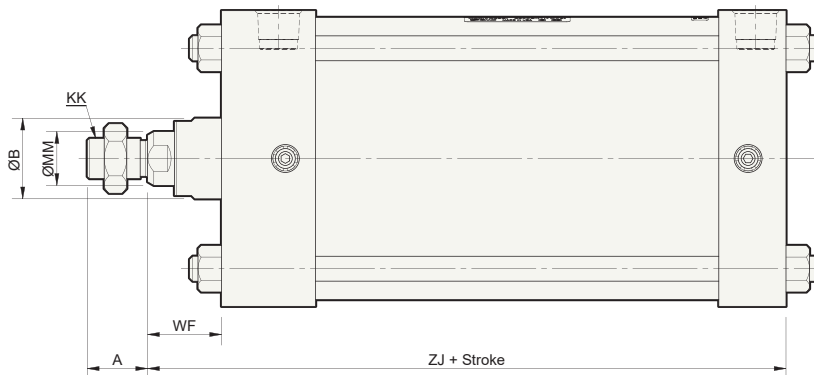

Bore Size (in)	ØMM	KK	A	ØB	WF	ZJ+
500 (5")	1.375	1-14	1.63	2.00	1.63	6.13
600 (6")	1.75	1 1/4-12	2.00	2.375	1.88	6.88
800 (8")	1.75	1 1/4-12	2.00	2.375	1.88	7.00

Rotated Ports (XC3 Option)

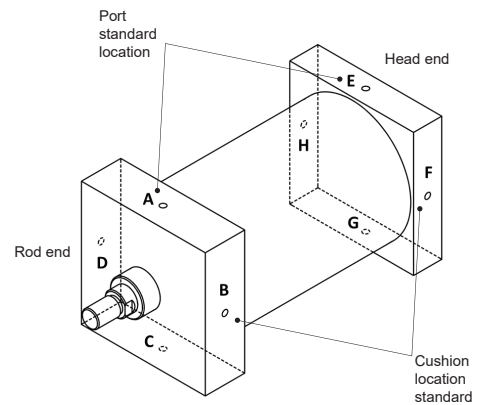

How to Order: -XC3 Port Cushion

- Standard Part Number Location. AB (A=port, B=cushion)
- Available on standard, XB5, XB6, XB7, XC6, and XC35
- Ports and cushions in same location on rod and head ends
- Standard available configurations: XC3BC, XC3CD, XC3DA, XC3AC, XC3DB, XC3AD, XC3BA, XC3CB, XC3DC
- Ports and cushions NOT aligned between Rod and Head ends available via RFS

Example: NCA1B500-0400-XC3BC (B = port, C = cushion)

Addition of NFPA Standard Threads for NCA1 Series

The NCA1 series is the NFPA Interchangeable tie-rod actuator and is available in bore sizes 1.5" to 8".

Previously, the only standard rod thread option on NCA1 was a "Small Male" (Nil) thread. The new NFPA rod thread options being added are:

- Short Female (SF)
- Intermediate Male (IM)
- Flanged (F)
- Full Male (FM)
- Plain (PL)

Previously requesting the above rod thread changes required a RFS.

See **next page** for dimensional information on these new NCA1 rod thread offerings.

The current NCA1 rod end standard is "Small Male" (Nil). The additional thread options, listed above, are valid on the entire NCA1 series with the following exceptions:

- *Not valid with K (non-rotating), W (double rod), M (male rod stud), KW (non-rotating, double rod)*
- *Not valid above cylinder stroke of 60.00"*
- *Not valid with J (Nylon Boot) or K (Neoprene Boot)*
- *Not valid with X-Options: XB7 (low temp), XC8 (adjustable stroke extension), XC11 (dual operation/single rod), and X119US (non-rotating oversized rod)*

For all questions, please contact your local SMC sales representative.

How To Order

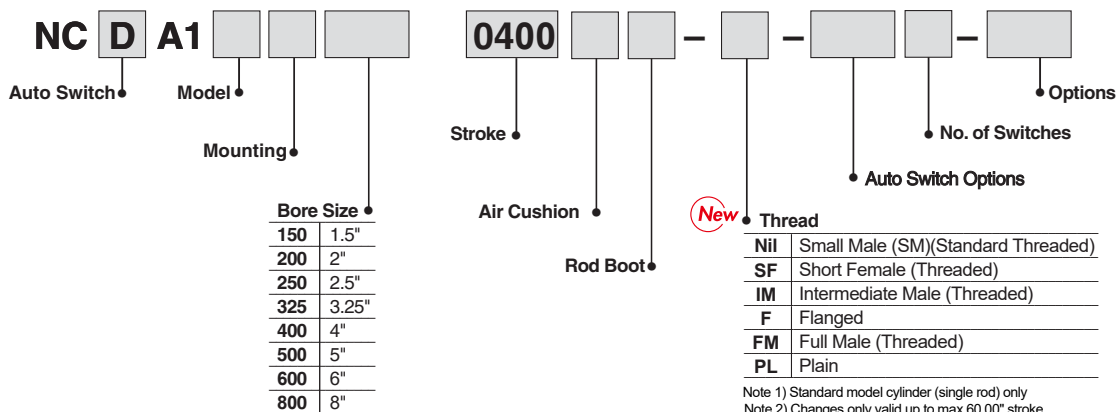

NFPA STANDARD PISTON ROD THREADS (5" TO 8" BORE)

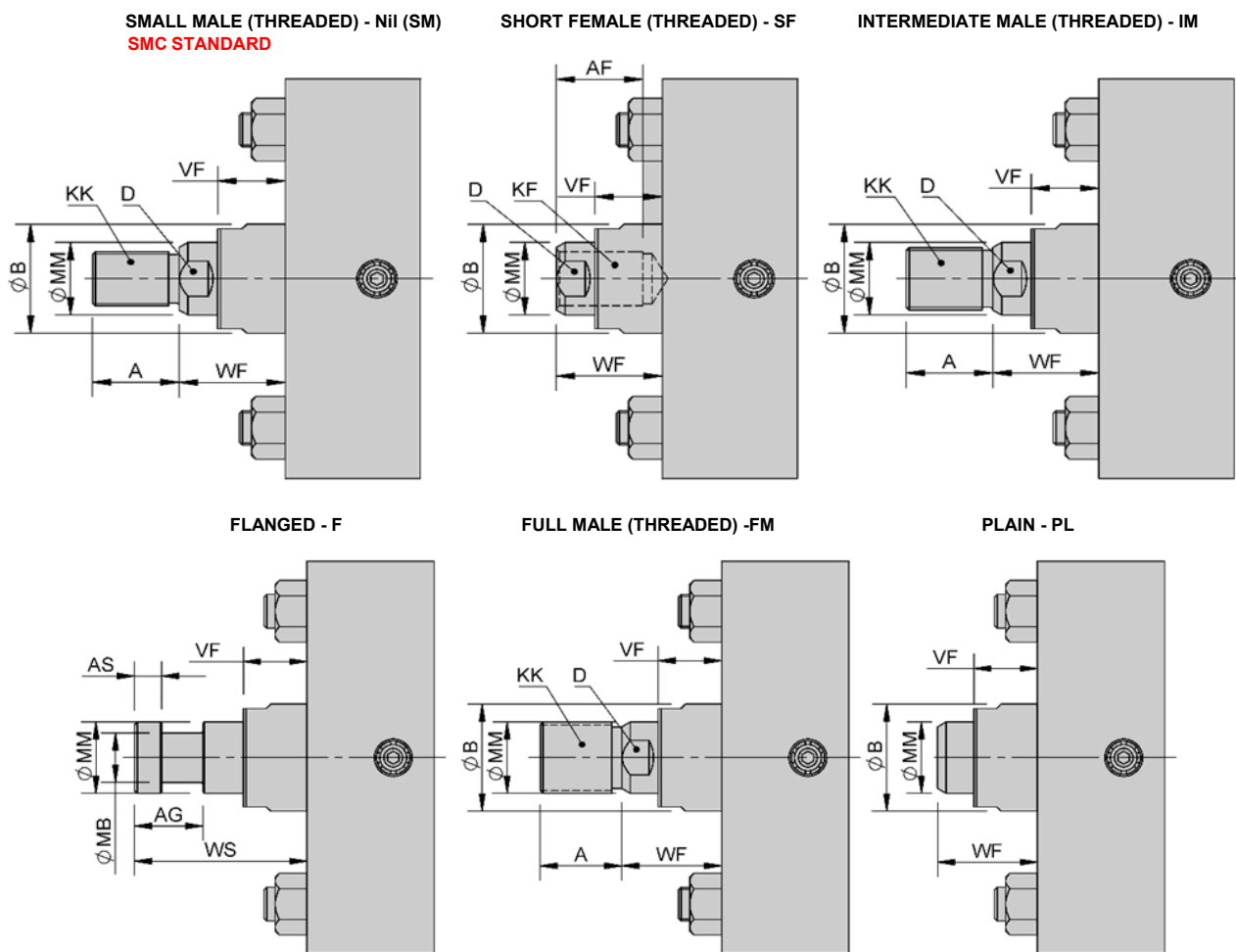

Bore Size (in)	Rod Thread						ØMM	A AF	ØB	D	VF	WF	For Flanged - F Only			
	Nil (SM)	SF	IM	F	FM	PL							WS	AG	AS	MB
	KK	KF	KK	KK	KK	KK										
500 (5")	3/4-16	3/4-16	7/8-14	No Thread	1-14	No Thread	1.000	1.13	1.500	0.88	0.88	1.38	2.38	0.94	0.374	0.69
	1-14	1-14	1 1/4-12		1 3/8-12		1.375	1.63	2.000	1.25	1.00	1.63	2.75	1.06	0.374	0.88
	1 1/4-12	1 1/4-12	1 1/2-12		1 3/4-12		1.750	2.00	2.375	1.50	1.13	1.88	3.13	1.31	0.499	1.13
600 (6")	1-14	1-14	1 1/4-12	No Thread	1 3/8-12	No Thread	1.375	1.63	2.000	1.25	1.00	1.63	2.75	1.06	0.374	0.88
	1 1/4-12	1 1/4-12	1 1/2-12		1 3/4-12		1.750	2.00	2.375	1.50	1.13	1.88	3.13	1.31	0.499	1.13
	1-14	1-14	1 1/4-12		1 3/8-12		1.375	1.63	2.000	1.25	1.00	1.63	2.75	1.06	0.374	0.88
800 (8")	1 1/4-12	1 1/4-12	1 1/2-12	No Thread	1 3/4-12	No Thread	1.750	2.00	2.375	1.50	1.13	1.88	3.13	1.31	0.499	1.13
	1-14	1-14	1 1/4-12		1 3/8-12		1.375	1.63	2.000	1.25	1.00	1.63	2.75	1.06	0.374	0.88
	1 1/4-12	1 1/4-12	1 1/2-12		1 3/4-12		1.750	2.00	2.375	1.50	1.13	1.88	3.13	1.31	0.499	1.13

Note 1) Dimensions in grey are for oversized rod (XB5)

Series NCA1 Cylinder

Large Bore

Eye Bracket

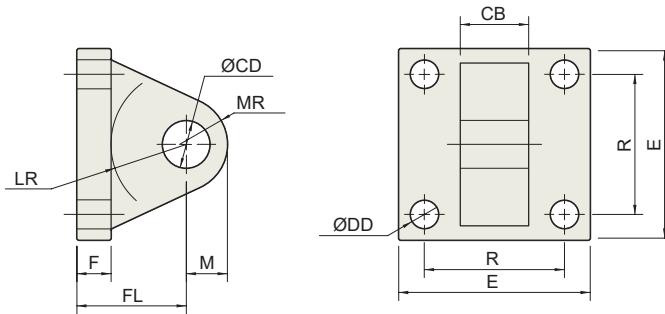

Dimensions

Part No.	CB	CD	DD	E	F	FL	LR	M	MR	R	Weight (lbs)
NCA1-P325	1 1/4	3/4	17/32	3 1/2	5/8	1 7/8	1 1/4	3/4	7/8	2.56	3.11
NCA1-P800	1 1/2	1	21/32	4 1/2	3/4	2 1/4	1 1/2	1	1 1/4	3.25	5.80
NCA1-P1000	2	1 3/8	21/32	5	7/8	3	2 1/8	1 3/8	1 5/8	3.81	10.42

Note: Pivot pin is not included

Clevis Bracket

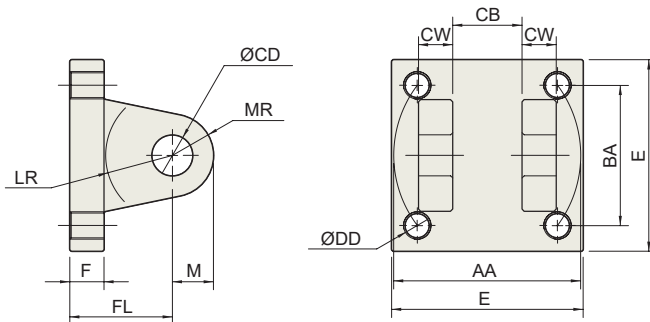

Dimensions

Part No.	AA	BA	CB	CD	CW	DD	E	F	FL	LR	M	MR	Weight (lbs)
NCA1-CB325	3.6	2 9/16	1.265	3/4	5/8	1/2-20	3 1/2	5/8	1 7/8	1 1/16	3/4	1 1/16	2.79
NCA1-CB800	4.6	3 1/4	1.515	1	3/4	5/8-18	4 1/2	3/4	2 1/4	1 1/4	1	1 1/8	5.45
NCA1-CB1000	5.4	3 13/16	2.032	1 3/8	1	5/8-18	5	7/8	3	1 7/8	1 3/8	1 3/4	9.89

Note: Pivot pin is not included.

Rod Clevis

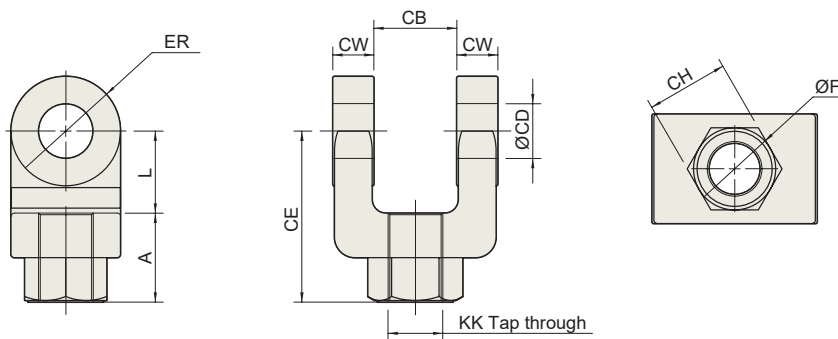

Dimensions

Part No.	CB	CD	CE	CH	CW	F	L	A	KK	ER	Weight (lbs)
NY-325	1.265	0.75	2 3/8	1 3/8	5/8	1 1/4	1 1/4	1 1/8	3/4-16	3/4	1.50
NY-800	1.515	1	3 1/8	1 1/2	3/4	1 1/2	1 1/2	1 5/8	1-14	1	3.78
NY-1000	3.032	1 3/8	4 1/8	2	1	2	2 1/8	2	1 1/4-12	1 3/8	9.32

Note: Jam nut, pivot, and cotter pins are included.

Alignment Coupler

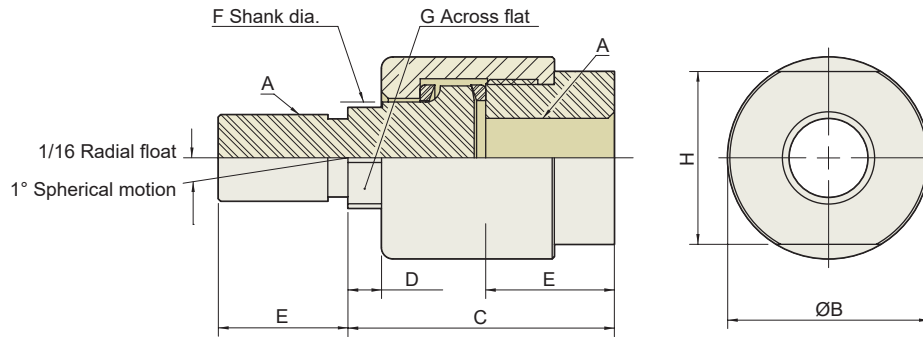

Dimensions

Part No.	A	B	C	D	E	F	G	H
NCA1-AC325	3/4-16	1 3/4	2 5/16	5/16	1 1/8	31/32	7/8	1 1/2
NCA1-AC800	1-14	2 1/2	2 15/16	1/2	1 5/8	1 3/8	1 1/4	2 1/4
NCA1-AC1000	1 1/4-12	2 1/2	2 15/16	1/2	1 5/8	1 3/8	1 1/4	2 1/4

Pivot Pins

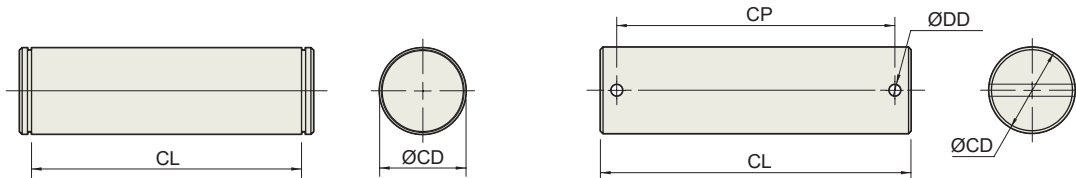

Dimensions

Part No.	CD	CL
NCA1-325	3/4	2 5/8
NCA1-800	1	3 1/8
NCA1-1000	1 3/8	4 1/8

Note: Retainer rings are included.

Dimensions

Part No.	CD	DD	CL	CP
NCDP-325	3/4	.140	3.10	2.72
NCDP-800	1	.140	3.60	3.22
NCDP-1000	1 3/8	.173	4.66	4.25

Note: Cotter pins are included.

Rod Jam Nut

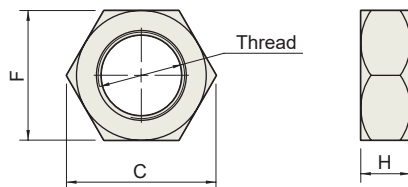

Dimensions

Part No.	C	F	H	Thread
JM-10	1.299	1 1/8	27/64	3/4-16UNF
JM-800	1.732	1 1/2	35/64	1-14UNF
JM-1000	2.165	1 7/8	23/32	1 1/4-12UNF

Dimensions per ASME B18.2.2 1987 (1999)

Rod Eye

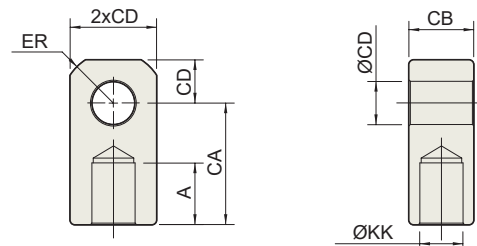

Dimensions

Part No.	A	CA	CB	CD	ER	KK	Weight (lbs)
NI-325	1 1/8	2 1/16	1 1/4	3/4	7/8	3/4-16	0.39
NI-800	1 5/8	2 13/16	1 1/2	1	1 3/16	1-14	1.04
NI-1000	2	3 7/16	2	1 3/8	1 9/16	1 1/4-12	2.37

Note: Jam nut is included.



Series NCA1 Safety Instructions

These safety instructions are intended to prevent a hazardous situation and/or equipment damage. These instructions indicate the level of potential hazard by a label of "**Caution**", "**Warning**" or "**Danger**". To ensure safety, be sure to observe ISO 4414 Note 1), JIS B 8370 Note 2) and other safety practices.

⚠ Caution : Operator error could result in injury or equipment damage.

⚠ Warning : Operator error could result in serious injury or loss of life.

⚠ Danger : In extreme conditions, there is a possible result of serious injury or loss of life.

Note 1) ISO 4414: Pneumatic fluid power – Recommendations for the application of equipment to transmission and control systems

Note 2) JIS B 8370: General Rules for Pneumatic Equipment

⚠ Warning

1. The compatibility of pneumatic equipment is the responsibility of the person who designs the pneumatic system or decides its specifications.

Since the products specified here are used in various operating conditions, their compatibility for the specific pneumatic system must be based on specifications or after analysis and/or tests to meet your specific requirements.

2. Only trained personnel should operate pneumatically operated machinery and equipment.

Compressed air can be dangerous if handled incorrectly. Assembly, handling or repair of pneumatic systems should be performed by trained and experienced operators.

3. Do not service machinery/equipment or attempt to remove components until safety is confirmed.

1. Inspection and maintenance of machinery/equipment should only be performed after confirmation of safe locked-out control positions.
2. When equipment is to be removed, confirm the safety process as mentioned above. Cut the supply pressure for this equipment and exhaust all residual compressed air in the system.
3. Before machinery/equipment is restarted, take measures to prevent shooting-out of cylinder piston rod, etc. (Bleed air into the system gradually to create back pressure.)

4. Contact SMC if the product is to be used in any of the following conditions:

1. Conditions and environments beyond the given specifications, or if product is used outdoors.
2. Installation on equipment in conjunction with atomic energy, railway, air navigation, vehicles, medical equipment, food and beverages, recreation equipment, emergency stop circuits, press applications, or safety equipment.
3. An application which has the possibility of having negative effects on people, property, or animals, requiring special safety analysis.

Series NCA1 Actuator Precautions 1

Be sure to read before handling.

Design

⚠ Warning

- 1. There is a possibility of danger of sudden action by air cylinders if sliding parts of machinery are twisted, due to external forces, etc.**

In such cases, human injury may occur; e.g., by catching hands or feet in the machinery, or damage to the machinery itself may occur. Therefore, the machine should be adjusted to operate smoothly and designed to avoid such dangers.

- 2. A protective cover is recommended to minimize the risk of personal injury.**

If a stationary object and moving parts of a cylinder are in close proximity, personal injury may occur. Design the structure to avoid contact with the human body.

- 3. Securely tighten all stationary parts and connected parts so that they will not become loose.**

Especially when a cylinder operates with high frequency or is installed where there is a lot of vibration, ensure that all parts remain secure.

- 4. A deceleration circuit or shock may be required.**

When a driven object is operated at high speed or the load is heavy, a cylinder's cushion will not be sufficient to absorb the impact. Install a deceleration circuit to reduce the speed before cushioning, or install an external shock absorber to relieve the impact. In this case, the rigidity of the machinery should also be examined.

- 5. Consider a possible drop in circuit pressure due to a power outage, etc.**

When a cylinder is used in a clamping mechanism, there is a danger of work pieces dropping if there is a decrease in clamping force due to a drop in circuit pressure caused by a power outage, etc. Therefore, safety equipment should be installed to prevent damage to machinery and/or human injury. Suspension mechanisms and lifting devices also require consideration for drop prevention.

- 6. Consider a possible loss of power source.**

Measures should be taken to protect against bodily injury and equipment damage in the event that there is a loss of power to equipment controlled by pneumatics, electricity or hydraulics, etc.

- 7. Design circuit that will prevent the driven object from shooting out.**

The driven object will shoot out at a high speed if one side of the cylinder is pressurized after the air inside the cylinder is exhausted; for example, when the cylinder is driven with exhaust center directional control valves or when it is started after the residual pressure inside the circuit is exhausted.

Such an event can possibly lead to bodily injury, by, for example catching in human limbs, or damage to the machinery. Therefore, select equipment and design circuits to prevent shoot-outs.

- 8. Consider emergency stops.**

Design so that human injury and/or damage to machinery and equipment will not be caused when machinery is stopped by a safety device under abnormal conditions, a power outage or a manual emergency stop.

- 9. Consider the action when operation is restarted after an emergency stop or abnormal stop.**

Design the machinery so that human injury or equipment damage will not occur upon restart of operation. When the cylinder has to be reset at the starting position, install safe manual control equipment.

Selection

⚠ Warning

- 1. Check the specifications.**

The products featured in this catalog are designed for use in industrial compressed air systems. If the products are used in conditions where pressure and/or temperature are outside range of specification, damage and/or malfunction may occur. Do not use in these conditions. (Refer to specifications.)

Consult SMC if you use a fluid other than compressed air.

- 2. Intermediate stops**

When intermediate stopping of a cylinder piston is performed with a 3 position closed center type directional control valve, it is difficult to achieve stopping positions as accurate and precise as with hydraulic pressure due to the compressibility of air.

Furthermore, since valves and cylinders, etc., are not guaranteed for zero air leakage, it may not be possible to hold a stopped position for an extended period of time. Contact SMC in case it is necessary to hold a stopped position for an extended period.

⚠ Caution

- 1. Operate within the limits of the maximum usable stroke.**

The piston rod will be damaged if operated beyond the maximum stroke. Refer to the cylinder model selection procedure for the maximum useable stroke.

- 2. Operate the piston within a range such that collision damage will not occur at the stroke end.**

The operation range should prevent damage from occurring when a piston, having inertial force, stop by striking the cover at the stroke end. Refer to the cylinder model selection procedure for the maximum usable stroke.

- 3. Use a speed controller to adjust the cylinder drive speed, gradually increasing from a low speed to the desired speed setting.**

- 4. Provide intermediate supports for long stroke cylinders.**

An intermediate support should be provided in order to prevent damage to a cylinder having a long stroke, due to problems such as sagging of the rod deflection of the cylinder tube, vibration and external load.

Actuator Precautions 2

Be sure to read before handling.

Mounting

⚠ Caution

1. **Be certain to match the rod shaft center with the load and direction of movement when connecting.**

When not properly matched, problem may arise with the rod and tube, and damage may be caused due to friction on areas such as the inner tube surface, bushings, rod surface, and seals.

2. **When an external guide is used, connect the rod end and the load in such a way that there is no interference at any point within the stroke.**

3. **Do not scratch or gouge the sliding parts of the cylinder tube or piston rod by striking or grasping them with other objects.**

Cylinder bores are manufactured to precise tolerances, so that even a slight deformation may cause faulty operation.

Moreover scratches or gouges, etc., in the piston rod may lead to damaged seals and cause air leakage.

4. **Prevent the seizure of rotating parts.**

Prevent the seizure of rotating parts (pins, etc.) by applying grease.

5. **Do not use until you can verify that equipment can operate properly.**

After mounting, repairs, or modification, etc., connect the air supply and electric power, and then confirm proper mounting by means of appropriate function and leak tests.

6. **Instruction manual**

The product should be mounted and operated after the instruction manual is thoroughly read and its contents are understood.

Keep the instruction manual where it can be referred to as needed.

1. **Preparation before piping**

Before piping is connected, it should be thoroughly blown out with air (flushing) or washed to remove chips, cutting oil and other debris from inside the pipe.

2. **Wrapping of pipe tape**

When screwing together pipes and fittings, etc., be certain that chips from the pipe threads and sealing material do not get inside the piping.

Also, when sealant tape is used, leave 1.5 to 2 thread ridges exposed at the end of the threads.

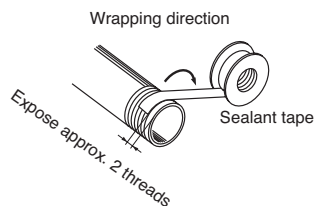

Cushion

⚠ Caution

1. **Readjust using the cushion needle.**

Cushions are adjusted at the time of shipment, however, the cushion needle on the cover should be readjusted when the product is put into service, based upon factors such as the size of the load and the operating speed. When the cushion needle is turned clockwise, the restriction becomes smaller and the cushion's effectiveness is increased. Tighten the lock nut securely after adjustment is performed.

2. **Do not use the cushion needle fully closed.**

This will cause damage to the seals.

⚠ Warning

1. **Use clean air.**

Do not use compressed air which includes chemicals, synthetic oils containing organic solvents, salt or corrosive gases, etc., as it can cause damage or malfunction.

⚠ Caution

1. **Install air filters.**

Install air filters at the upstream side of valves. The filtration degree should be 5 μ m or finer.

2. **Install an after cooler, air dryer or water separator, etc.**

Air that includes excessive drainage may cause malfunction of valves and other pneumatic equipment. To prevent this, install an after cooler, air dryer or water separator, etc.

3. **Use the product within the specified range of fluid and ambient temperature.**

Take measures to prevent freezing, since moisture in circuits can be frozen under 5°C, and this may cause damage to seals and lead to malfunction.

Refer to SMC's "Air Cleaning Equipment" catalog for further details on compressed air quality.

Maintenance

⚠ Warning

1. **Removal of equipment, and supply/exhaust of compressed air.**

Before any machinery or equipment is removed, first ensure that the appropriate measures are in place to prevent the fall or erratic movement of driven objects and equipment, then cut off the electric power and reduce the pressure in the system to zero. Only then should you proceed with the removal of any machinery and equipment.

When machinery is restarted, proceed with caution after confirming measures to prevent cylinder lurching.

⚠ Caution

1. **Drain flushing**

Remove drainage from air filters regularly. (Refer to specifications.)

Auto Switch Precautions 1

Be sure to read before handling.

Design & Selection

⚠ Warning

1. Confirm the specifications.

Read the specifications carefully and use this product appropriately. The product may be damaged or malfunction if it is used outside the range of specifications for current load, voltage, temperature or impact.

2. Take precautions when multiple cylinders are used close together.

When multiple auto switch cylinders are used in close proximity, magnetic field interference may cause the switches to malfunction. Maintain a minimum cylinder separation of 40mm.

3. Pay attention to the length of time that a switch is ON at an intermediate stroke position.

When an auto switch is placed at an intermediate position of the stroke and a load is driven at the time the piston passes, the auto switch will operate, but if the speed is too great the operating time will be shortened and the load may not operate properly. The maximum detectable piston speed is:

$$V \text{ (mm/s)} = \frac{\text{Auto switch operating range (mm)} \times 1000}{\text{Time load applied (ms)}}$$

4. Keep wiring as short as possible.

<Reed switches>

As the length of the wiring to a load gets longer, the rush current at switching ON becomes greater, and this may shorten the product's life. (The switch will stay ON all the time.)

Use a contact protection box when the wire length is 5m or longer.

<Solid state switches>

Although wire length should not affect switch function, use a wire 100m or shorter.

5. Pay attention to the internal voltage drop of the switch.

<Reed switches>

- 1) Switches with an indicator light (Except D-Z76)

- If auto switches are connected in series as shown below, take note that there will be a large voltage drop because of internal resistance in the light emitting diodes. (Refer to internal voltage drop in the auto switch specifications.)

[The voltage drop will be "n" times larger when "n" auto switches are connected.]

Even though an auto switch operates normally, the load may not operate.

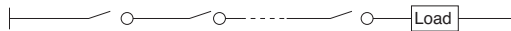

⚠ Warning

- In the same way, when operating under a specified voltage, although an auto switch may operate normally, the load may not operate. Therefore, the formula below should be satisfied after confirming the minimum operating voltage of the load.

$$\text{Supply voltage} - \text{Internal voltage drop of switch} > \text{Minimum operating voltage of load}$$

- 2) If the internal resistance of a light emitting diode causes a problem, select a switch without an indicator light (Model D-Z80).

<Solid state switches>

- 3) Generally, the internal voltage drop will be greater with a 2 wire solid state auto switch than with a reed switch. Take the same precautions as in 1).

Also, note that a 12VDC relay is not applicable.

6. Pay attention to leakage current.

<Solid state switches>

With a 2 wire solid state auto switch, current (leakage current) flows to the load to operate the internal circuit even when in the OFF state.

$$\text{Operating current of load (OFF condition)} > \text{Leakage current}$$

If the criteria given in the above formula are not met, it will not reset correctly (stays ON). Use a 3 wire switch if this specification will not be satisfied.

Moreover, leakage current flow to the load will be "n" times larger when "n" auto switches are connected in parallel.

7. Do not use a load that generates surge voltage.

<Reed switches>

If driving a load such as a relay that generates a surge voltage, use a contact protection box.

<Solid state switches>

Although a zener diode for surge protection is connected at the output side of a solid state auto switch, damage may still occur if the surge is applied repeatedly. When a load, such as a relay or solenoid which generates surge is directly driven, use a type of switch with a built-in surge absorbing element.

8. Cautions for use in an interlock circuit

When an auto switch is used for an interlock signal requiring high reliability, devise a double interlock system to avoid trouble by providing a mechanical protection function, or by also using another switch (sensor) together with the auto switch.

Also perform periodic maintenance and confirm proper operation.

9. Ensure sufficient clearance for maintenance activities.

When designing an application, be sure to allow sufficient clearance for maintenance and inspections.

Auto Switch Precautions 2

Be sure to read before handling.

Mounting & Adjustment

⚠ Warning

1. Do not drop or bump.

Do not drop, bump or apply excessive impacts (300m/s² or more for reed switches and 1000m/s² or more for solid state switches) while handling. Although the body of the switch may not be damaged, the inside of the switch could be damaged and cause a malfunction.

2. Do not carry a cylinder by the auto switch lead wires.

Never carry a cylinder by its lead wires. This may not only cause broken lead wires, but it may cause internal elements of the switch to be damaged by the stress.

3. Mount switches using the proper tightening torque.

If a switch is tightened beyond the range of tightening torque, the mounting screws or switch may be damaged.

On the other hand, tightening below the range of tightening torque may allow the switch to slip out of position. (Refer to switch mounting instructions for each series for switch mounting, moving, and tightening torque, etc.)

4. Mount a switch at the center of the operating range.

Adjust the mounting position of an auto switch so that the piston stops at the center of the operating range (the range in which a switch is ON). (The mounting position shown in the catalog indicates the optimum position at stroke end.) If mounted at the end of the operating range (around the borderline of ON and OFF), operation will be unstable.

Wiring

⚠ Warning

1. Avoid repeatedly bending or stretching lead wires.

Broken lead wires will result from repeatedly applying bending stress or stretching force to the lead wires.

2. Be sure to connect the load before power is applied.

<2 wire type>

If the power is turned ON when an auto switch is not connected to a load, the switch will be instantly damaged because of excess current.

3. Confirm proper insulation of wiring.

Be certain that there is no faulty wiring insulation (contact with other circuits, ground fault, improper insulation between terminals, etc.). Damage may occur due to excess current flow into a switch.

4. Do not wire with power lines or high voltage lines.

Wire separately from power lines or high voltage lines, avoiding parallel wiring or wiring in the same conduit with these lines. Control circuits containing auto switches may malfunction due to noise from these other lines.

Wiring

⚠ Warning

5. Do not allow short circuit of loads.

<Reed switches>

If the power is turned ON with a load in a short circuited condition, the switch will be instantly damaged because of excess current flow into the switch.

<Solid state switches>

All models of PNP output type switches do not have built-in short circuit protection circuits.

Note that if a load is short circuited, the switch will be instantly damaged as in the case of reed switches.

*Take special care to avoid reverse wiring with the brown (red) power supply line and the black (white) output line on 3 wire type switches.

6. Avoid incorrect wiring.

<Reed switches>

A 24VDC switch with indicator light has polarity. The brown (red) lead wire is (+), and the blue (black) lead wire is (-).

1) If connections are reversed, a switch will operate, however, the light emitting diode will not light up.

Also note that a current greater than that specified will damage a light emitting diode and it will no longer operate.

Applicable models: D-Z73

<Solid state switches>

1) If connections are reversed on a 2 wire type switch, the switch will not be damaged if protected by a protection circuit, but the switch will always stay in an ON state. However, it is still necessary to avoid reversed connections, since the switch could be damaged by a load short circuit in this condition.

*2) If connections are reversed (power supply line + and power supply line -) on a 3 wire type switch, the switch will be protected by a protection circuit. However, if the power supply line (+) is connected to the blue (black) wire and the power supply line (-) is connected to the black (white) wire, the switch will be damaged.

* Lead wire color changes

Lead wire colors of SMC switches and related products have been changed in order to meet NECA (Nippon Electric Control Equipment Industries Association) Standard 0402 for production beginning September, 1996 and thereafter. Please refer to the tables provided.

Special care should be taken regarding wire polarity during the time that the old colors still coexist with the new colors.

2 wire

	Old	New
Output (+)	Red	Brown
Output (-)	Black	Blue

3 wire

	Old	New
Power supply	Red	Brown
GND	Black	Blue
Output	White	Black

Solid state with diagnostic output

	Old	New
Power supply	Red	Brown
GND	Black	Blue
Output	White	Black
Diagnostic output	Yellow	Orange

Solid state with latch type diagnostic output

	Old	New
Power supply	Red	Brown
GND	Black	Blue
Output	White	Black
Latch type diagnostic output	Yellow	Orange

Auto Switch Precautions 3

Be sure to read before handling.

Operating Environment

Warning

1. Never use in an atmosphere of explosive gases.

The structure of auto switches is not intended to prevent explosion. Never use in an atmosphere with an explosive gas since this may cause a serious explosion.

2. Do not use in an area where a magnetic field is generated.

Auto switches will malfunction or magnets inside cylinders will become demagnetized. (Consult SMC regarding the availability of a magnetic field resistant auto switch.)

3. Do not use in an environment where the auto switch will be continually exposed to water.

Although switches satisfy IEC standard IP67 construction (JIS C 0920: watertight structure), do not use switches in applications where continually exposed to water splash or spray. Poor insulation or swelling of the potting resin inside switches may cause malfunction.

4. Do not use in an environment with oil or chemicals.

Consult SMC if auto switches will be used in an environment with coolant, cleaning solvent, various oils or chemicals. If auto switches are used under these conditions for even a short time, they may be adversely affected by improper insulation, malfunction due to swelling of the potting resin, or hardening of the lead wires.

5. Do not use in an environment with temperature cycles.

Consult SMC if switches are used where there are temperature cycles other than normal temperature changes, as there may be adverse effects inside the switches.

6. Do not use in an environment where there is excessive impact shock.

<Reed switches>

When excessive impact (300m/s² or more) is applied to a reed switch during operation, the contact point will malfunction and generate or cut off a signal momentarily (1ms or less). Consult SMC regarding the need to use a solid state switch depending upon the environment.

7. Do not use in an area where surges are generated.

<Solid state switches>

When there are units (solenoid type lifter, high frequency induction furnace, motor, etc.) which generate a large amount of surge in the area around cylinders with solid state auto switches, this may cause deterioration or damage to the switch. Avoid sources of surge generation and disorganized lines.

8. Avoid accumulation of iron waste or close contact with magnetic substances.

When a large amount of iron waste such as machining chips or spatter is accumulated, or a magnetic substance (something attracted by a magnet) is brought into close proximity with an auto switch cylinder, it may cause the auto switch to malfunction due to a loss of the magnetic force inside the cylinder.

Maintenance

Warning

1. Perform the following maintenance periodically in order to prevent possible danger due to unexpected auto switch malfunction.

1) Secure and tighten switch mounting screws.

If screws become loose or the mounting position is dislocated, retighten them after readjusting the mounting position.

2) Confirm that there is no damage to lead wires.

To prevent faulty insulation, replace switches or repair lead wires, etc., if damage is discovered.

3) Confirm the lighting of the green light on the 2 color indicator type switch.

Confirm that the green LED is on when stopped at the established position. If the red LED is on, the mounting position is not appropriate. Readjust the mounting position until the green LED lights up.

Other

Warning

1. Consult SMC concerning water resistance, elasticity of lead wires, and usage at welding sites, etc.

Limited warranty and Disclaimer/Compliance Requirements

The product used is subject to the following “Limited warranty and Disclaimer” and “Compliance Requirements”.
Read and accept them before using the product.

Limited warranty and Disclaimer

1. The warranty period of the product is 1 year in service or 1.5 years after the product is delivered, whichever is first.^{Note)}
Also, the product may have specified durability, running distance or replacement parts. Please consult your nearest sales branch.
2. For any failure or damage reported within the warranty period which is clearly our responsibility, a replacement product or necessary parts will be provided. This limited warranty applies only to our product independently, and not to any other damage incurred due to the failure of the product.
3. Prior to using SMC products, please read and understand the warranty terms and disclaimers noted in the specified catalog for the particular products.

Note) Vacuum pads are excluded from this 1 year warranty.

A vacuum pad is a consumable part, so it is warranted for a year after it is delivered. Also, even within the warranty period, the wear of a product due to the use of the vacuum pad or failure due to the deterioration of rubber material are not covered by the limited warranty.

Compliance Requirements

1. The use of SMC products with production equipment for the manufacture of weapons of mass destruction (WMD) or any other weapon is strictly prohibited.
2. The exports of SMC products or technology from one country to another are governed by the relevant security laws and regulations of the countries involved in the transaction. Prior to the shipment of an SMC product to another country, assure that all local rules governing that export are known and followed.



SMC Corporation of America
10100 SMC Blvd., Noblesville, IN 46060
www.smcusa.com

SMC Pneumatics (Canada) Ltd.
www.smc Pneumatics.ca

(800) SMC.SMC1 (762-7621)

e-mail: sales@smcusa.com

For International inquiries: www.smcworld.com