

Blow Gun with Flow Rate Adjustment Function

The flow rate can be easily adjusted according to the amount of force applied to the lever.

Relationship between the amount of force applied to the lever and the flow rate (Image)

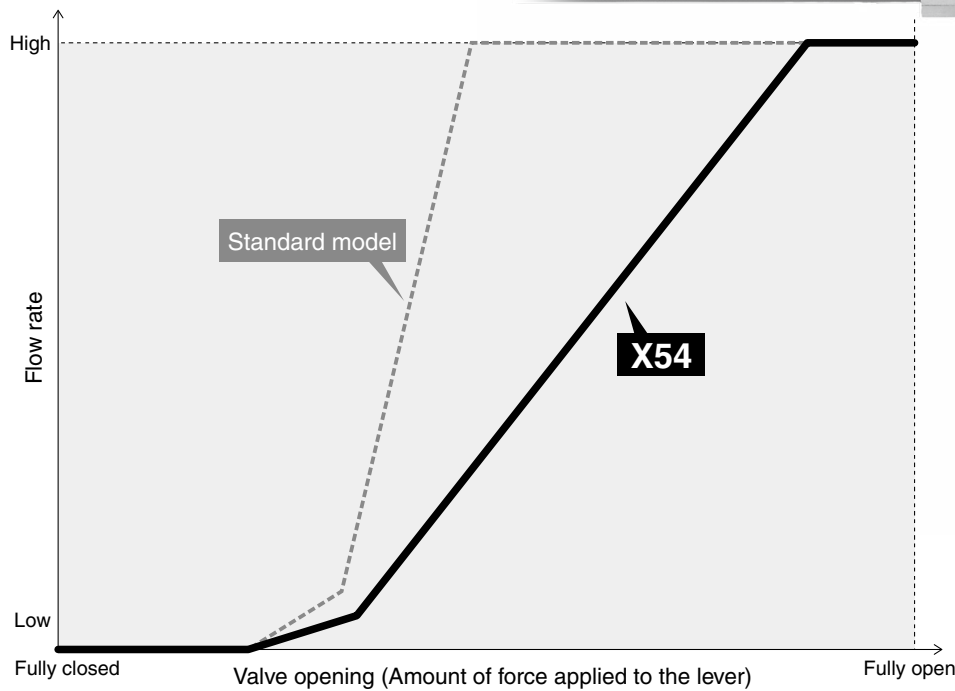

Application Examples

For the blowing of lightweight workpieces

By limiting the amount of blow air, the blowing away of workpieces can be prevented.

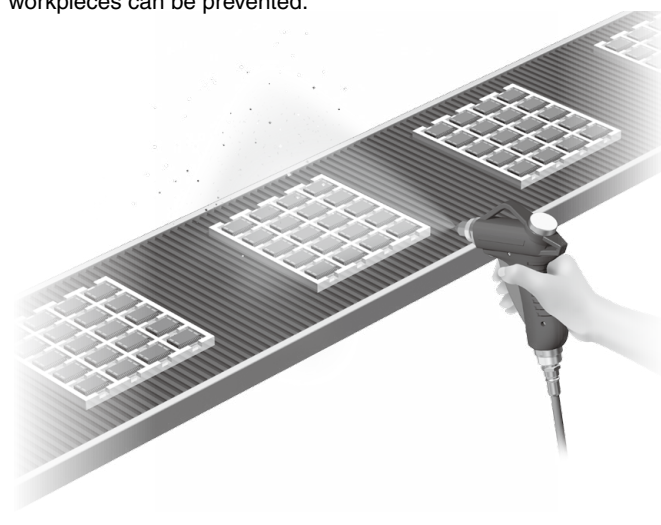

For the blowing off of water droplets

By limiting the amount of blow air, the spraying of water droplets can be minimized.

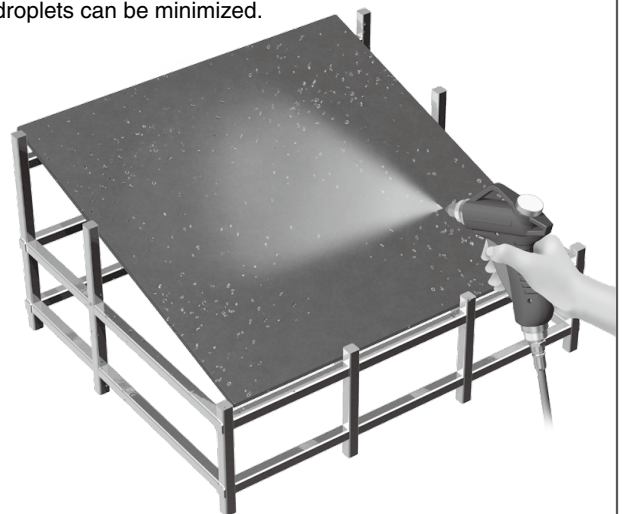

VMG1□-□-□-*X54*

How to Order

VMG 1 1 **W** - **02** - **32** - **X54**

Piping entry

1	Bottom
----------	--------

Body color

W	White
BU	Dark blue

• With flow rate adjustment function

Connection size

Symbol	Piping connection method	Size and part no.	
02	Threaded	Thread size	Rc1/4
03			Rc3/8
N02			NPT1/4
N03			NPT3/8
F02			G1/4
F03			G3/8
11	S coupler plug	Part no. of coupler used	KK4P-02MS
12			KK130P-02MS
H06	Metric size One-touch fitting	Part no. of fitting used	KQ2H06-02AS
H08			KQ2H08-02AS
H10			KQ2H10-02AS
H07	Inch size One-touch fitting	Part no. of fitting used	KQ2H07-35AS
H09			KQ2H09-35AS
H11			KQ2H11-35AS

- * The S coupler or fitting is shipped together with the product.
- * The port size is Rc1/4 if using an S coupler plug.
- * The blow gun port size is Rc1/4 if using a metric size One-touch fitting.
- * The blow gun port size is NPT1/4 if using an inch size One-touch fitting.

Nozzle

Symbol	Type	Nozzle size	Nozzle part no.
Nil	Without nozzle		
01	Male thread nozzle	ø1	KN-R02-100
02		ø1.5	KN-R02-150
03		ø2	KN-R02-200
04		ø2.5	KN-R02-250
05		ø3	VMG1-R02-300
06		ø3.5	VMG1-R02-350
07		ø4	VMG1-R02-400
11	High-efficiency nozzle	ø1	KNH-R02-100
12		ø1.5	KNH-R02-150
13		ø2	KNH-R02-200
21	Low-noise nozzle with male thread	ø0.75 x 4	KNS-R02-075-4
22		ø0.9 x 8	KNS-R02-090-8
23		ø1 x 4	KNS-R02-100-4
24		ø1.1 x 8	KNS-R02-110-8

Extension nozzle

Symbol	Type	Nozzle length	Nozzle size	Nozzle part no.
31	ø6 copper*1 extension nozzle	300 mm	ø1.5	VMG1-06-150-300
32			ø2	VMG1-06-200-300
33		600 mm	ø1.5	VMG1-06-150-600
34			ø2	VMG1-06-200-600
35		100 mm	ø1.5	VMG1-06-150-100
36			ø2	VMG1-06-200-100
37	150 mm	ø1.5	VMG1-06-150-150	
38		ø2	VMG1-06-200-150	
41	ø8 copper*1 extension nozzle	100 mm	ø2.5	VMG1-08-250-100
42			ø3	VMG1-08-300-100
43			ø3.5	VMG1-08-350-100
44		150 mm	ø2.5	VMG1-08-250-150
45			ø3	VMG1-08-300-150
46			ø3.5	VMG1-08-350-150
47		300 mm	ø2.5	VMG1-08-250-300
48			ø3	VMG1-08-300-300
49			ø3.5	VMG1-08-350-300
50		600 mm	ø2.5	VMG1-08-250-600
51			ø3	VMG1-08-300-600
52			ø3.5	VMG1-08-350-600

- *1 This is the part number for the extension nozzle and fitting set. The extension nozzle and fitting are shipped together with the product. Refer to "How to attach extension nozzle" in the operation manual for assembly procedures.

Specifications

Fluid	Air
Operating pressure range	0 to 1.0 MPa
Proof pressure	1.5 MPa
Ambient and fluid temperatures	-5 to 60°C (No freezing)
Flow rate characteristics (With nozzle removed)	C (dm ³ /s·bar): 3.3*1 (Effective area: 16.5 mm ²)
Port size	Rc, NPT, G 1/4, 3/8
Piping entry	Bottom
Nozzle port size	Rc1/4
Weight (Main unit only)	165 g
Operational force (when the valve is fully open)	9 N*2

- *1 Though the value is smaller than that of the standard model, the flow rate characteristics when a nozzle is mounted are the same as those of the standard model.
- *2 The operational force is higher than that of the standard model for ease of flow adjustment with the lever.

Dimensions

*1 Reference dimensions after installation

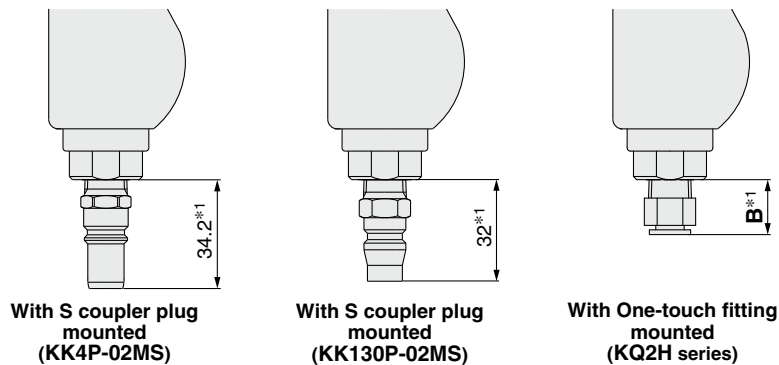
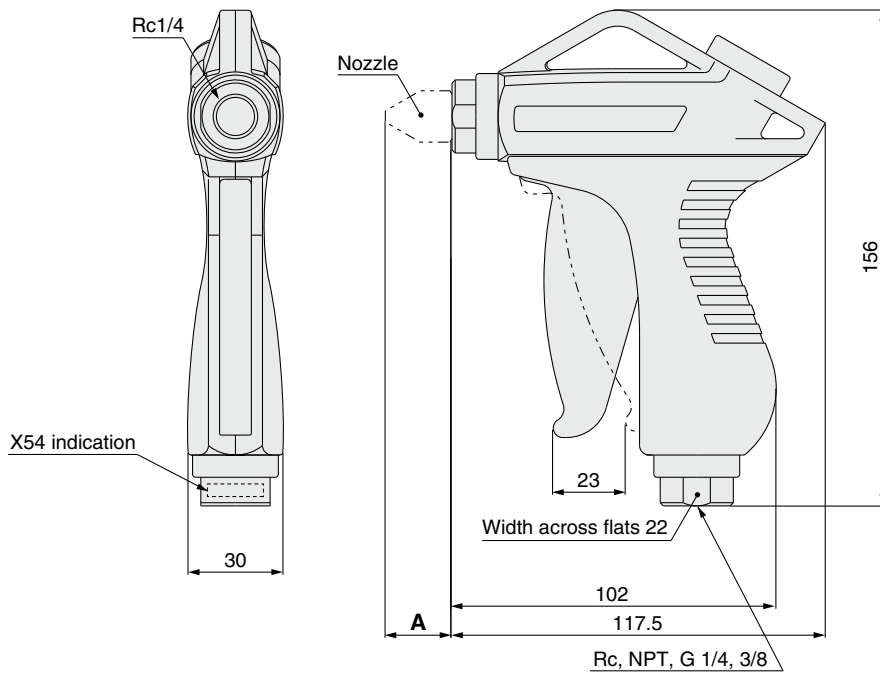

Symbol	Type	Nozzle part no.	Nozzle size	A*1 [mm]	
01	Male thread nozzle	KN-R02-100	ø1	23.4	
02		KN-R02-150	ø1.5	23	
03		KN-R02-200	ø2	22.5	
04		KN-R02-250	ø2.5	22.1	
05		VMG1-R02-300	ø3	22	
06		VMG1-R02-350	ø3.5	21.5	
07		VMG1-R02-400	ø4		
11	High-efficiency nozzle	KNH-R02-100	ø1	44	
12		KNH-R02-150	ø1.5		
13		KNH-R02-200	ø2		
21	Low-noise nozzle with male thread	KNS-R02-075-4	ø0.75 x 4	12	
22		KNS-R02-090-8	ø0.9 x 8		
23		KNS-R02-100-4	ø1 x 4		
24		KNS-R02-110-8	ø1.1 x 8		
31	ø6 copper extension nozzle*1	Nozzle length: 300 mm	VMG1-06-150-300	ø1.5	298
32			VMG1-06-200-300	ø2	
33		Nozzle length: 600 mm	VMG1-06-150-600	ø1.5	598
34			VMG1-06-200-600	ø2	
35		Nozzle length: 100 mm	VMG1-06-150-100	ø1.5	98
36			VMG1-06-200-100	ø2	
37		Nozzle length: 150 mm	VMG1-06-150-150	ø1.5	148
38			VMG1-06-200-150	ø2	

*1 Reference dimensions after installation

Symbol	Type	Nozzle part no.	Nozzle size	A*1 [mm]		
41		Nozzle length: 100 mm	VMG1-08-250-100	ø2.5	98	
42			VMG1-08-300-100	ø3		
43			VMG1-08-350-100	ø3.5		
44	ø8 copper extension nozzle*1	Nozzle length: 150 mm	VMG1-08-250-150	ø2.5	148	
45			VMG1-08-300-150	ø3		
46			VMG1-08-350-150	ø3.5		
47		Nozzle length: 300 mm	VMG1-08-250-300	ø2.5		298
48			VMG1-08-300-300	ø3		
49		VMG1-08-350-300	ø3.5			
50	Nozzle length: 600 mm	VMG1-08-250-600	ø2.5	598		
51		VMG1-08-300-600	ø3			
52		VMG1-08-350-600	ø3.5			

Type	One-touch fitting part no.	B*1 [mm]
Metric size One-touch fitting	KQ2H06-02AS	12
	KQ2H08-02AS	17.3
	KQ2H10-02AS	22.6
Inch size One-touch fitting	KQ2H07-35AS	12.3
	KQ2H09-35AS	17.7
	KQ2H11-35AS	20.7

*1 Reference dimensions after installation

 **Safety Instructions** | Be sure to read the "Handling Precautions for SMC Products" (M-E03-3) and "Operation Manual" before use.