

Electric Stopper Cylinder



* Excludes the lever detection switch

Designed in response to customers' requests for a motorized conveyor line

With 2 control types available depending on the application

Controller		Controllerless		Size	Stroke [mm]	Mounting type	Built-in magnet for auto switch	Rod end shape		
Action	Series	Chamfered	Roller					Lever		
Controller Step motor	LEBQ-X1	32	20	Through-hole Screw	—	●	●	●		
		50	30		—	●	●	●		
Controllerless DC motor	LEBQ-X31	40	20	Through-hole Screw	●	—	—	●		
		50	30		●	—	—	●		
	LEBH-X3	63	30	Flange	●	—	—	●		
		80	40		●	—	—	●		

Max. weight of transferred object [kg]

* Friction coefficient $\mu = 0.1$

Controller Step motor LEBQ-X1	Size 32	25
	Size 50	130
Controllerless DC motor LEBQ-X31 LEBH-X3	Size 40	70
	Size 50	400
	Size 63	520
	Size 80	800

Ensured stopper cylinder mounting interchangeability with equivalent stopper performance*1

Electric Stopper Cylinder		Interchangeable mounting	Stopper Cylinder	
Series	Size		Series	Size
LEBQ-X1 p. 4	32	↔	RSQ Series	32
	50			50
LEBQ-X31 p. 11	40	↔	RSQ Series	40
LEBH-X3 p. 16	50	↔	RS2H Series	50
	63			63
	80			80

*1 For details, refer to the Web Catalog of each series.

Easy replacement of shock absorbers

Replaceable just by loosening the set screw

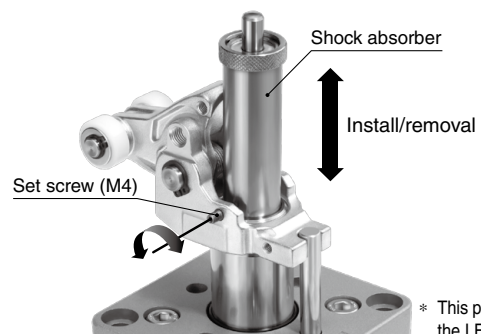

* This picture shows the LEBH-X3.

LEB □ Series



22-E787

Controllerless Type LEBQ40-X31, LEBH50/63/80-X3

Controllable with only an ON/OFF signal

- Easy startup/Reduced wiring work
- No need of controller installation space



Size: 40



Sizes: 50, 63, 80

Power Consumption

No power consumption during rising operations and while holding the raised end

	Holding raised-end ①	Start descending ②	Holding lowered-end ③	Start rising ④
Power consumption [W]	Zero	48 W	4.8 W	Zero
Power supply	OFF	ON	ON	OFF
Motor	OFF	ON	OFF	OFF
Solenoid	OFF	ON	ON	OFF

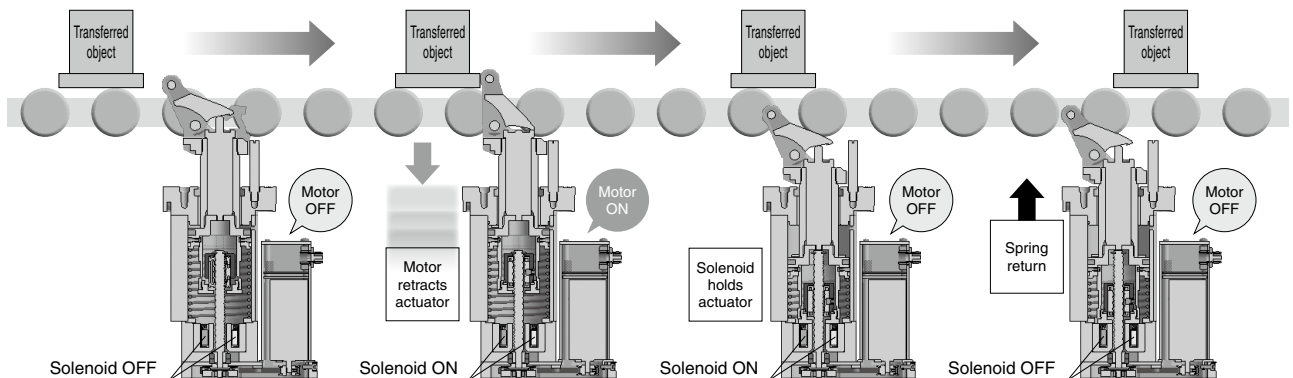

Operation

When power is OFF (de-energized), raised-end is held with spring force only (1). When power is ON (energized), the roller starts to descend powered by the motor and by the coil (2). After the roller reaches the retracted end, the motor stops automatically (Motor OFF) and it is held by the solenoid force only (3). When power is OFF, it starts to rise with spring force (4).

Maximum speed of transferred object

Series	Speed [m/min]*1
LEBQ40-X31	30
LEBH50/63/80-X3	40

*1 Friction coefficient $\mu = 0.1$

Auto switch compatible * Only for controllerless type

For checking operating position

Applicable to the D-M9□, D-M9□W (2-color indicator)

* The auto switches should be ordered separately.

For details, refer to the **Web Catalog** of each series.

2-Color Indicator Solid State Auto Switch

Accurate setting of the mounting position can be performed without mistakes.

A green light lights up at the optimum operating range.

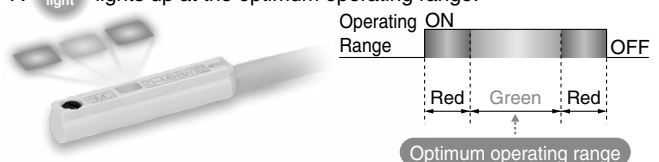

Controller Type **LEBQ32/50-X1**



- Various communication protocols supported
- The current position is held when the power supply is turned OFF.
- Compact: Reduced height due to horizontal motor mounting

Maximum speed of transferred object

Rod end shape	Speed [m/min]
Chamfered type, roller type	20
Lever type	30*1

*1 Friction coefficient $\mu = 0.1$

A wide variety of rod end shapes

Chamfered type









Roller type









Lever type



Compatible Controllers/Drivers

Type	Step Data Input Type 	Programless Type 	Pulse Input Type 	EtherCAT Direct Input Type 	With STO Sub-Function EtherCAT Direct Input Type 	EtherNet/IP Direct Input Type 	With STO Sub-Function EtherNet/IP Direct Input Type 
Series	JXC51 JXC61	LECP1	LECPA	JXCE1	JXCEF	JXC91	JXC9F
Features	Parallel I/O type	Capable of setting up operation (step data) without using a PC or teaching box	Operation by pulse signals	EtherCAT direct input	With STO sub-function EtherCAT direct input	EtherNet/IP™ direct input	With STO sub-function EtherNet/IP™ direct input
Compatible motor	Step motor (Servo/24 VDC)						
Max. number of step data	64 points	14 points	—	64 points			
Power supply voltage	24 VDC						

Type	PROFINET Direct Input Type 	With STO Sub-Function PROFINET Direct Input Type 	DeviceNet Direct Input Type 	IO-Link Direct Input Type 	With STO Sub-Function IO-Link Direct Input Type 	CC-Link Direct Input Type 
Series	JXCP1	JXCPF	JXCD1	JXCL1	JXCLF	JXCM1
Features	PROFINET direct input	With STO sub-function PROFINET/IO-Link direct input	DeviceNet® direct input	IO-Link direct input	With STO sub-function IO-Link direct input	CC-Link direct input
Compatible motor	Step motor (Servo/24 VDC)					
Max. number of step data	64 points					
Power supply voltage	24 VDC					

Related Product

High Performance High Rigidity Guide Rod Type LEG Series

Max. weight of transferred object

75 kg (Size 25)/100 kg (Size 32)/150 kg (Size 40)

High performance step motor controller

Max. acceleration/deceleration: 5000 mm/s²

With internal battery-less absolute encoder

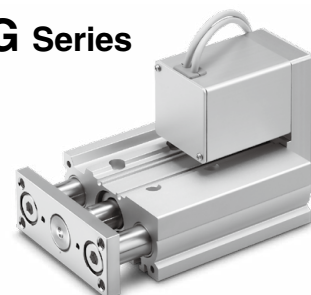

Electric Stopper Cylinder / Controller Type LEBQ32/50-X1 Series

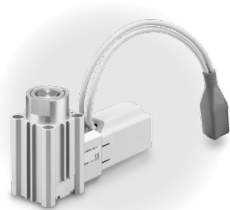

Model Selection	p. 4
How to Order	p. 5
Specifications	p. 7
Construction	p. 8
Dimensions	p. 9

Electric Stopper Cylinder / Controllerless Type LEBQ40-X31 Series



Model Selection	p. 11
How to Order	p. 12
Specifications	p. 12
Construction	p. 13
Dimensions	p. 14
Auto Switch Mounting	p. 15

Electric Stopper Cylinder / Controllerless Type LEBH50/63/80-X3 Series



Model Selection	p. 16
How to Order	p. 17
Specifications	p. 17
Construction	p. 18
Dimensions	p. 19
Lever Detection Switch (Proximity Switch)/E2E-X2D1-N	p. 22
Auto Switch Mounting	p. 22

Specific Product Precautions	p. 23
------------------------------------	-------

LEBQ□-X1 Series Model Selection

Operating Range

Example 1

Transfer speed: 15 m/min
Weight of transferred object: 40 kg
Roller type

<Selection Procedure>

From graph 1, determine the intersection of a transfer speed of 15 m/min on the horizontal axis and a transfer weight of 40 kg on the vertical axis, and select the **LEBQ□50□-30□-X1**, which is within the cylinder operating area.

Graph 1
Roller/Round Bar/Chamfered

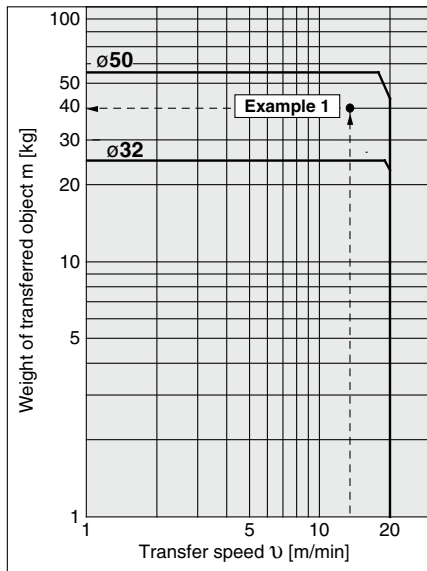

Example 2

Transfer speed: 15 m/min
Weight of transferred object: 60 kg
Friction coefficient $\mu = 0.1$
Lever type

<Selection Procedure>

From graph 2, determine the intersection of a transfer speed of 15 m/min on the horizontal axis and a transfer weight of 60 kg on the vertical axis, and select the **LEBQ□50□-30□-X1**, which is within the cylinder operating area.

Graph 2
Lever type (with shock absorber)

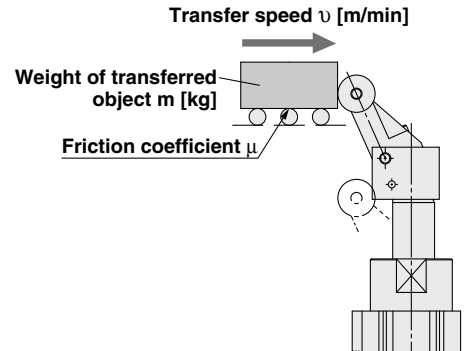
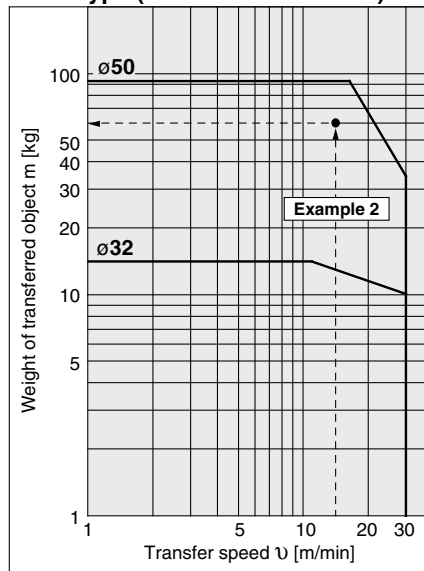

- * The graph 2 shows the case of a Lever Type with a friction coefficient $\mu = 0.1$ and at normal temperatures (20 to 25°C).
- * When selecting cylinders, confirm the Specific Product Precautions as well.

Electric Stopper Cylinder Controller Type



LEBQ□-X1 Series

How to Order

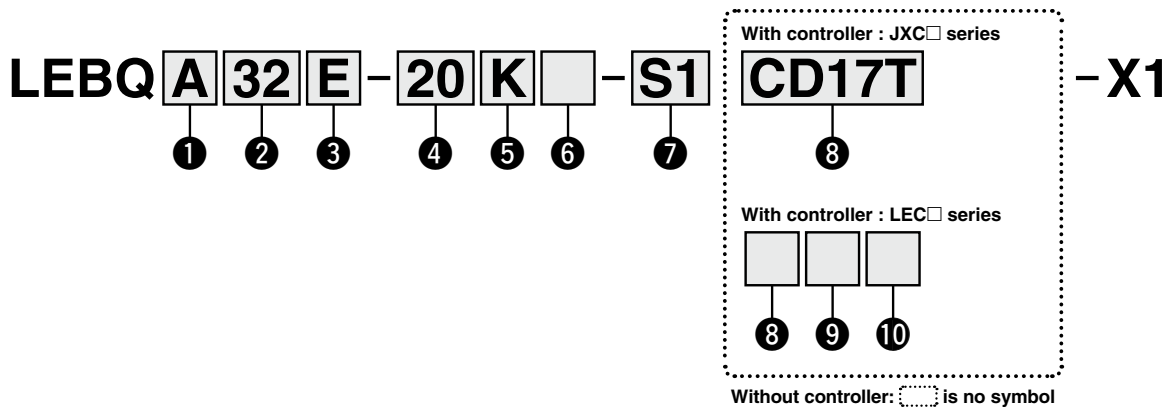

① Mounting

A	Ends tapped
B	Through hole

② Size

32
50

④ Stroke [mm]

Symbol	Size
20	32
30	50

③ Stopper direction

E	Opposite side of motor	
R	Motor right side	
L	Motor left side	
M	Motor side	

* For rod end shape option "K," the direction is the chamfered direction.

⑤ Rod end shape

K	Chamfered type
R	Roller type
L	Lever type (with shock absorber)
B	Lever type (with shock absorber adjustment)
C	Lever type (with shock absorber adjustment + cancel cap)
D	Lever type (with shock absorber adjustment + lock)
E	Lever type (with shock absorber adjustment + cancel cap + lock)

⑥ Motor option

Nil	None
C	With motor cover

* Indication in drawings: C

⑦ Actuator cable type/length

Nil	Without cable
S1	Standard cable 1.5 m
S3	Standard cable 3 m
S5	Standard cable 5 m
R1	Robotic cable (Flexible cable) 1.5 m
R3	Robotic cable (Flexible cable) 3 m
R5	Robotic cable (Flexible cable) 5 m
R8	Robotic cable (Flexible cable) 8 m*1
RA	Robotic cable (Flexible cable) 10 m*1
RB	Robotic cable (Flexible cable) 15 m*1
RC	Robotic cable (Flexible cable) 20 m*1

*1 Produced upon receipt of order (Robotic cable only)

JXC□ Series

8 Controller

Nil	Without controller
C□1□□	With controller

C D 1 7 T

Interface (Communication protocol/Input/Output)

Symbol	Type	Number of axes, Special specification	
		Standard	With STO sub-function
5	Parallel input (NPN)	●	
6	Parallel input (PNP)	●	
E	EtherCAT	●	●
9	EtherNet/IP™	●	●
P	PROFINET	●	●
D	DeviceNet®	●	
L	IO-Link	●	●
M	CC-Link	●	

Mounting

7	Screw mounting
8*6	DIN rail

Number of axes, Special specification

Symbol	Number of axes	Specification
1	Single axis	Standard
F	Single axis	With STO sub-function

Communication plug connector, I/O cable*7

Symbol	Type	Applicable interface
Nil	Without accessory	—
S	Straight type communication plug connector	DeviceNet® CC-Link Ver. 1.10
T	T-branch type communication plug connector	
1	I/O cable (1.5 m)	Parallel input (NPN) Parallel input (PNP)
3	I/O cable (3 m)	
5	I/O cable (5 m)	

LEC□ Series

AN 1 □

8 9 10

8 Controller/Driver type*1

Nil	Without controller/driver	
1N	LECP1*2 (Programless type)	NPN
1P		PNP
AN	LECPA*2, *3 (Pulse input type)	NPN
AP		PNP

9 I/O cable length*4

Nil	Without cable (Without communication plug connector)	
1	1.5 m	
3	3 m*5	
5	5 m*5	

10 Controller/Driver mounting

Nil	Screw mounting
D	DIN rail*6

*1 For more information on controllers/drivers and supported motors, refer to the "Compatible Controllers/Drivers" table on page 2.

*2 Only available for the motor type "Step motor"

*3 When the pulse input signal is open collector, order the current limiting resistor (LEC-PA-R-□) separately after checking the **Web Catalog**.

*4 When "Without controller/driver" is selected for the controller/driver type, an I/O cable cannot be selected. If an I/O cable is required, refer to the **Web Catalog**.

*5 When "Pulse input type" is selected for controller/driver types, pulse input usable only with differential. Only 1.5 m cables usable with open collector

*6 The DIN rail is not included. It must be ordered separately.

*7 Select "Nil" for anything other than DeviceNet®, CC-Link, or parallel input.

Select "Nil," "S," or "T" for DeviceNet® or CC-Link.

Select "Nil," "1," "3," or "5" for parallel input.

Trademark

EtherNet/IP® is a registered trademark of ODVA, Inc.

DeviceNet® is a registered trademark of ODVA, Inc.

EtherCAT® is registered trademark and patented technology, licensed by Beckhoff Automation GmbH, Germany.

LEBQ□-X1 Series

Specifications

Model		LEBQ32-X1	LEBQ50-X1
Actuator specifications	Stroke [mm]	20	30
	Speed [mm/s]	80	135
	Screw lead [mm]	5	8
	Impact/Vibration resistance [m/sec ²]*1	150/30	
	Actuation type	Slide screw + Cam	
	Operating temperature range [°C]	5 to 40	
	Operating humidity range [%RH]	90 or less (No condensation and freezing)	
Electric specifications	Motor size	□28	□42
	Motor type	Step motor (Servo/24 VDC)	
	Encoder (Angular displacement sensor)	Incremental	
	Rated voltage [V]	24 VDC ±10%	
	Power [W]*2	Max. power 37	Max. power 46

Weight

[kg]

Rod end configuration	LEBQ32-X1	LEBQ50-X1
Chamfered type, Roller type	0.81	1.76
Lever with built-in shock absorber	0.90	1.99

*1 Impact resistance: No malfunction occurred when the actuator was tested with a drop tester in both an axial direction and a perpendicular direction to the lead screw. (The test was performed with the actuator in the initial state.)

Vibration resistance: No malfunction occurred in a test ranging between 45 to 2000 Hz. The test was performed in both an axial direction and a perpendicular direction to the lead screw. (The test was performed with the actuator in the initial state.)

*2 Indicates the max. power during operation (including the controller)

This value can be used for the selection of the power supply.

* Since this product is not equipped with a magnet, auto switch cannot be used.

* This product can only be mounted in the vertical upward position. (Please install the product so that the rod is facing vertically upward.)

Construction

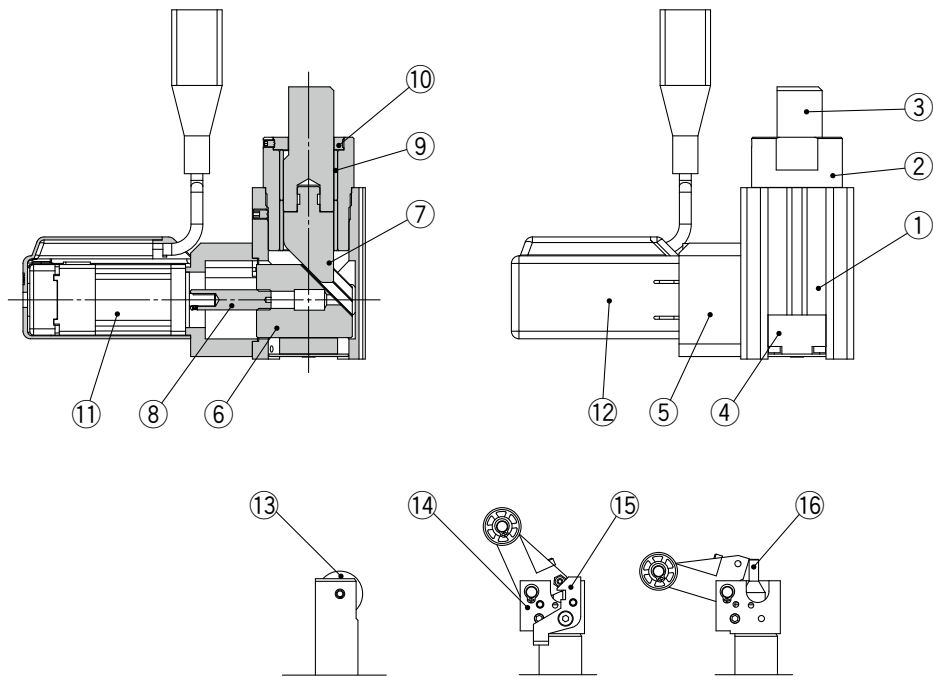

Component Parts

No.	Description	Material	Note
1	Cylinder tube	Aluminium alloy	Anodized
2	Rod cover	Aluminium alloy	Anodized
3	Piston rod	Carbon steel	Hard chrome plating
4	Cam receiver	Aluminium alloy	Anodized
5	Housing	Aluminium alloy	Anodized
6	Cam A	Stainless steel	Heat treatment + Special treatment
7	Cam B	Stainless steel	Heat treatment + Special treatment
8	Slide screw shaft	Stainless steel	Heat treatment + Special treatment

No.	Description	Material	Note
9	Bushing	—	
10	Non-rotating guide	Rolled steel	
11	Step motor (Servo/24 VDC)	—	
12	Motor cover	Synthetic resin	"With cover" only
13	Roller	Synthetic resin	"Roller type" only
14	Lever holder assembly	—	"Lever type" only
15	Lock mechanism assembly	—	"With lock mechanism" only
16	Cancel cap assembly	—	"With cancel cap" only

LEBQ□-X1 Series

Dimensions

LEBQ□32M-20K□-X1

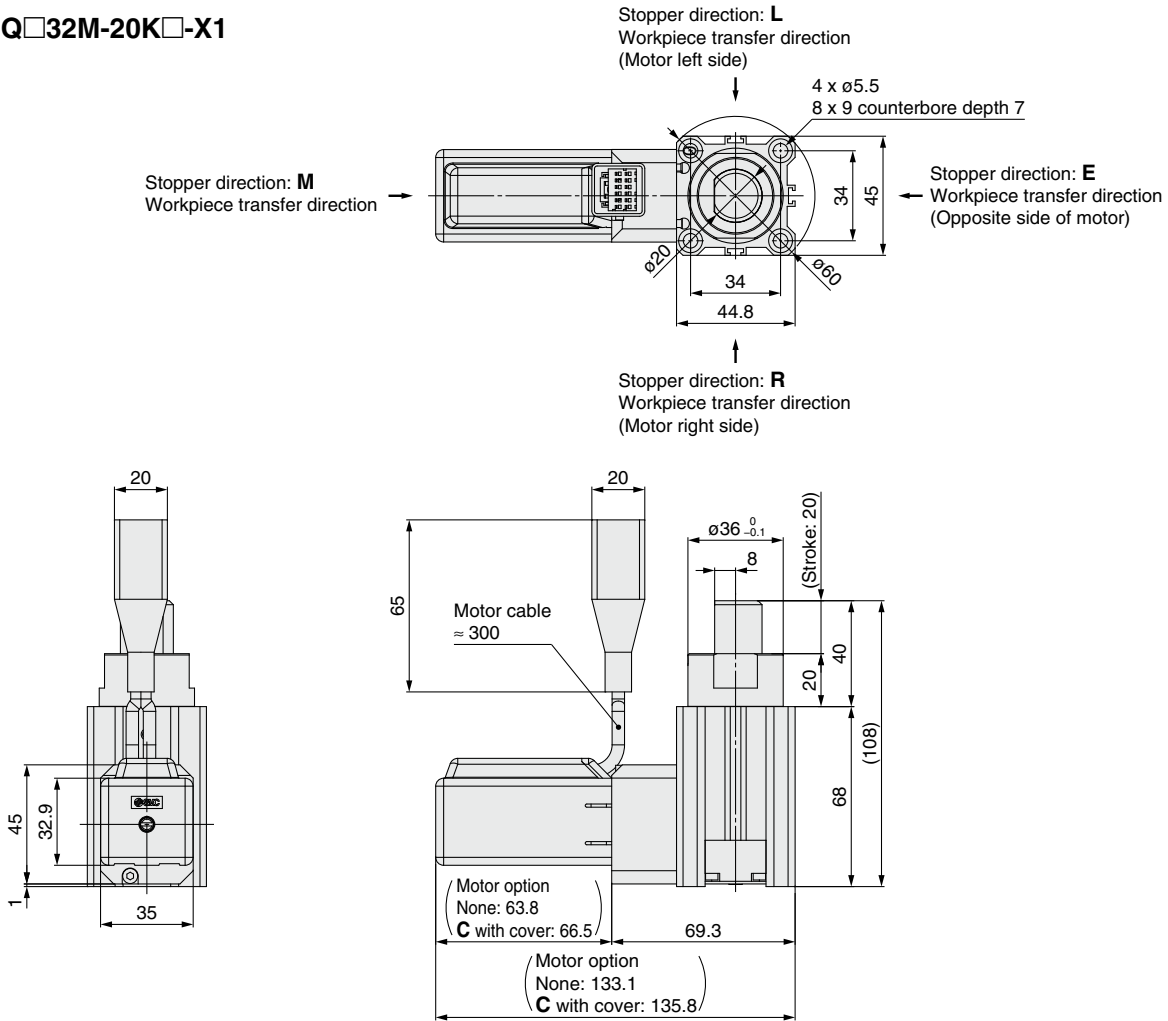

Fig. 1 Rod end shape R: For roller type

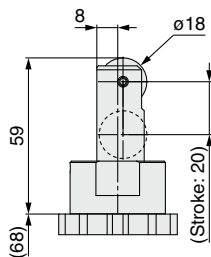

Fig. 2 Rod end shape L/B/C/D/E: For lever type

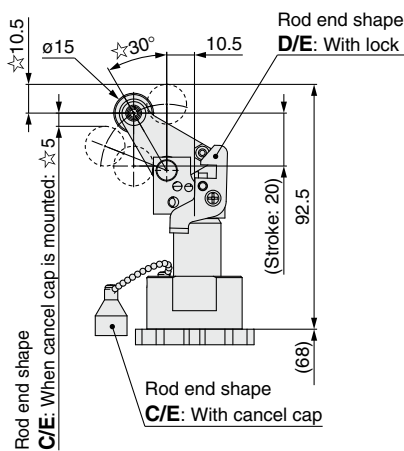
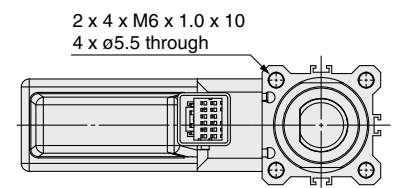

Fig. 3 Mounting A: For both ends tapped type



Rod end shape B/C/D/E: For lever type (with shock absorber adjustment)

This drawing shows when the adjustment bolt is lowered (max. energy absorption).
The ☆ dimension changes when the adjustment bolt is raised (reduced energy absorption).

- * This drawing shows the "with motor cover" specification.
- * This drawing shows the "motor side" stopper direction specification.
- * This drawing shows the "chamfered type" rod end shape specification.

Refer to Fig. 1 and 2 for others specifications.

Adjustment bolt lowered (max. energy absorption) → Adjustment bolt raised (min. energy absorption)

☆5	→	☆6
☆10.5	→	☆9
☆30°	→	☆20°

Dimensions

LEBQ□50M-30□□-X1

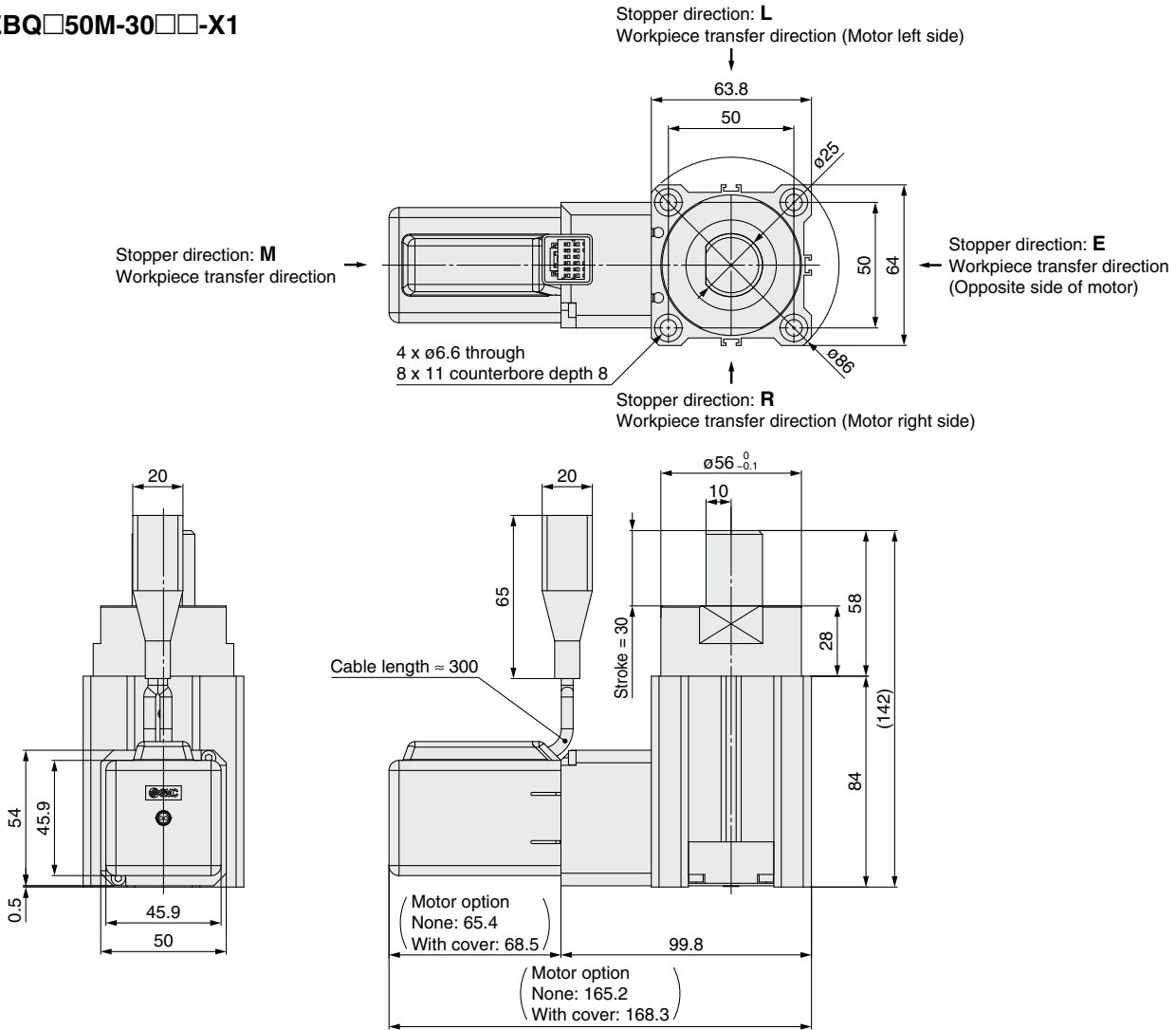

Fig. 1 Rod end shape R: For roller type

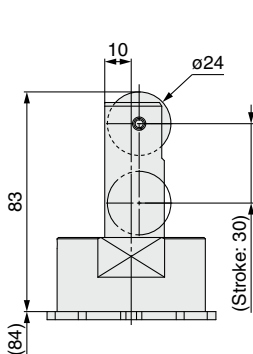

Fig. 2 Rod end shape L/B/C/D/E: For lever type

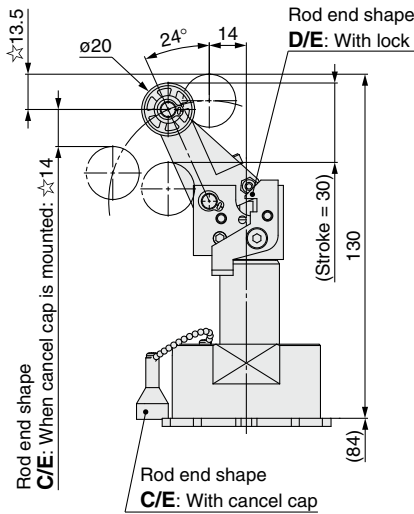
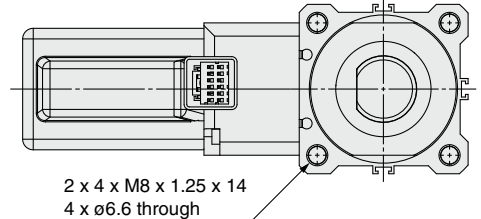

Fig. 3 Mounting A: For both ends tapped type



Rod end shape B/C/D/E: For lever type (with shock absorber adjustment)
This drawing shows when the adjustment bolt is lowered (max. energy absorption).
The \star dimension changes when the adjustment bolt is raised (reduced energy absorption).

Adjustment bolt lowered (max. energy absorption)		
→ Adjustment bolt raised (min. energy absorption)		
$\star 14$	→	$\star 16$
$\star 3.5$	→	$\star 11.5$
$\star 24^\circ$	→	$\star 16^\circ$

* This drawing shows the "with motor cover" specification.
* This drawing shows the "motor side" stopper direction specification.
* This drawing shows the "chamfered type" rod end shape specification.
Refer to Fig. 1 and 2 for others specifications.

LEBQ40-X31 Series Model Selection

Operating Range

Example Transfer speed: 15 m/min
Weight of transferred object: 50 kg
Friction coefficient $\mu = 0.1$

<Selection Procedure>

From the graph, determine the intersection of a transfer speed of 15 m/min on the horizontal axis and a transfer weight of 50 kg on the vertical axis, and confirm that it is within the usage range.

Lever type (with shock absorber)

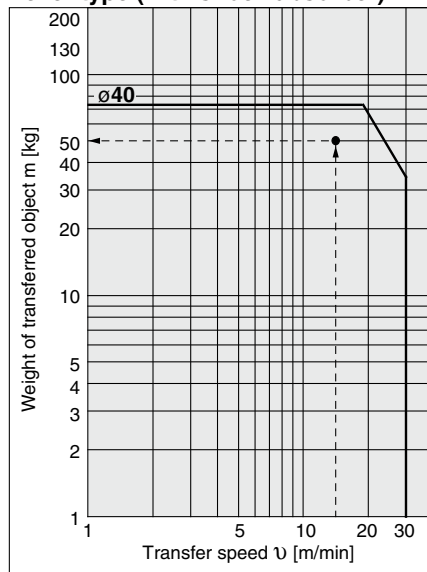

- * When the coefficient of friction is $\mu = 0.1$ at normal temperatures (20 to 25°C)
- * When selecting a model, be sure to check the "Specific Product Precautions" as well.

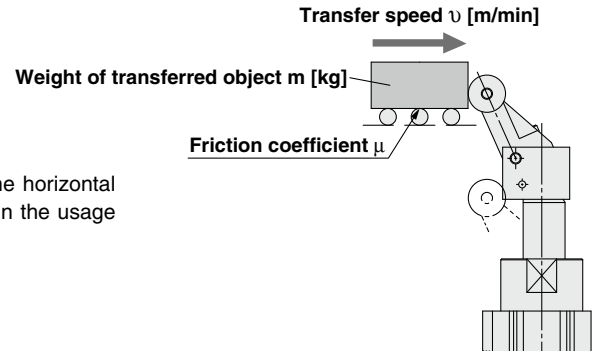

Electric Stopper Cylinder Controllerless Type



LEBQ□-X31 Series

How to Order

LEBQ 40 **E** **K** - 20 T □ □ - X31

①
②
③
④
⑤
⑥
⑦

① Size

40

② Lever direction

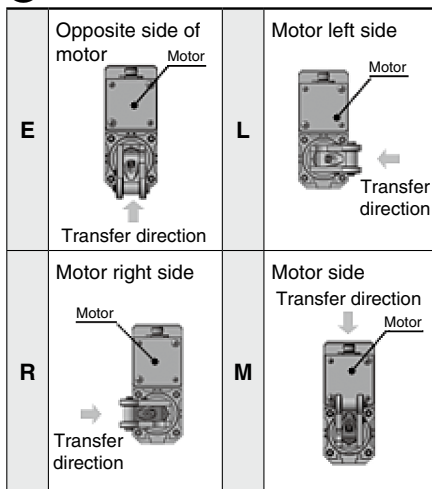

③ Lead [mm]

K Basic

④ Stroke [mm]

20 20

⑤ Action

T Single acting/
spring extend

⑥ Roller material

Nil	Resin
M	Carbon steel

⑦ Rod end configuration

B	Lever with built-in shock absorber	None
C	(energy absorbing adjustable)	With cancel cap
D		With lock mechanism
E		With lock + cancel cap

Specifications

Actuator specifications	Stroke [mm]	20
	Mounting orientation*3	Vertical (extending direction: top)
	Rising (extending operation) time [sec]	1 or less
	Descending (retracting operation) [sec]	1 or less (No lateral load)
	Action*1	Single acting/spring extend
	Rod end configuration	Lever with built-in shock absorber
	Actuation type	Ball screw + Belt
	Operating frequency [c.p.m]	3 or less
	Operating temperature range [°C]	5 to 40
	Operating humidity range [%RH]	90 or less (No freezing)
Product weight [kg]	2.6 (Without option)	
Electric specifications	Motor size	ø38
	Motor type	DC motor
	Rated voltage [V]	24 VDC ±10%
	Power consumption [W]	48
	Lower end standby power [W]*2	4.8

*1 This actuator holds the raised-end when de-energized. (Spring return)

*2 This actuator holds the lowered-end with solenoid only when de-energized.

*3 This actuator can be used in vertical directions only.

* The motor will be turned OFF automatically by the internal circuit board after the actuator stops.
A dedicated controller or driver is not necessary.

* The applicable auto switch is the D-M9□ series.
(Please refer to the **Web Catalog** for details.)

* A short break function is included with this cylinder for protection.

Short break function: a function that slows the driving motor down if the rotation speed is over the designated value.

* Beware of inrush current of approx. 5 A when the power supply is turned on.

Choose the equipment used when the power supply is turned such as relay considering the inrush current.

LEBQ□-X31 Series

Construction

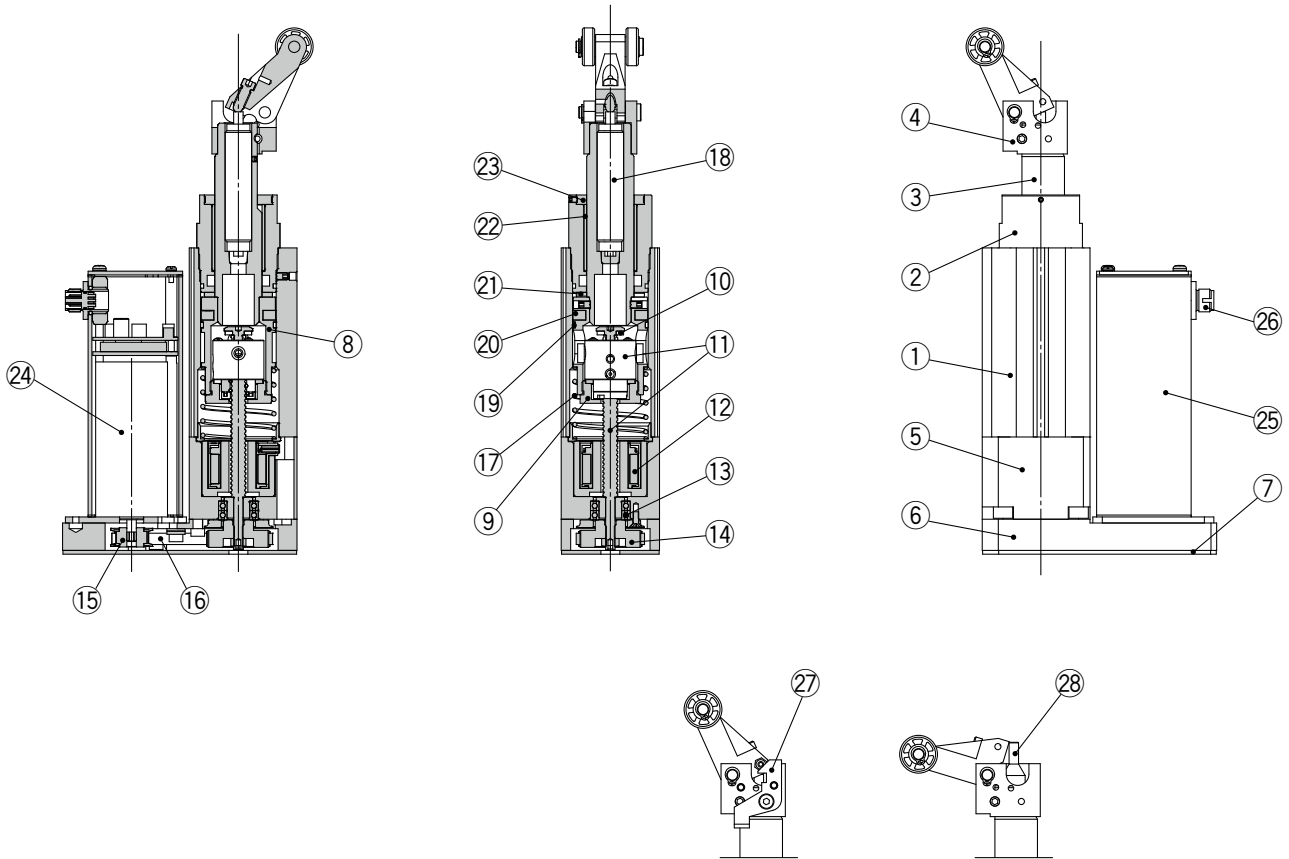

Component Parts

No.	Description	Material	Note
1	Cylinder tube	Aluminium alloy	Anodized
2	Rod cover	Aluminium alloy	
3	Piston rod	Carbon steel	Hard chrome plating
4	Lever holder assembly	—	
5	Housing	Aluminium alloy	Anodized
6	Return box	Aluminium alloy	Anodized
7	End plate	Aluminium alloy	Anodized
8	Piston	Aluminium alloy	Anodized
9	Piston cap	Carbon steel	Chromated
10	Urethane washers	Urethane	
11	Ball screw nut assembly	—	
12	Solenoid assembly	—	
13	Bearing	—	
14	Speed reduction pulley	Aluminium alloy	

No.	Description	Material	Note
15	Motor pulley	—	
16	Belt	—	
17	Spring	Steel wire	Chromated
18	Shock absorber	—	
19	Wear ring	Synthetic resin	
20	Plastic magnet	—	
21	Bumper	Synthetic resin	
22	Bushing	—	
23	Rod seal	—	
24	Motor	—	
25	Motor cover	Aluminium alloy	Anodized
26	Connector assembly	—	
27	Lock mechanism assembly	—	"With lock mechanism" only
28	Cancel cap assembly	—	"With cancel cap" only

Dimensions

LEBQ40EK-20T□□-X31

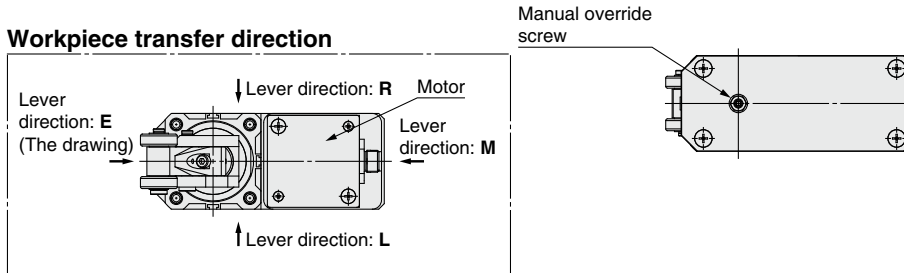
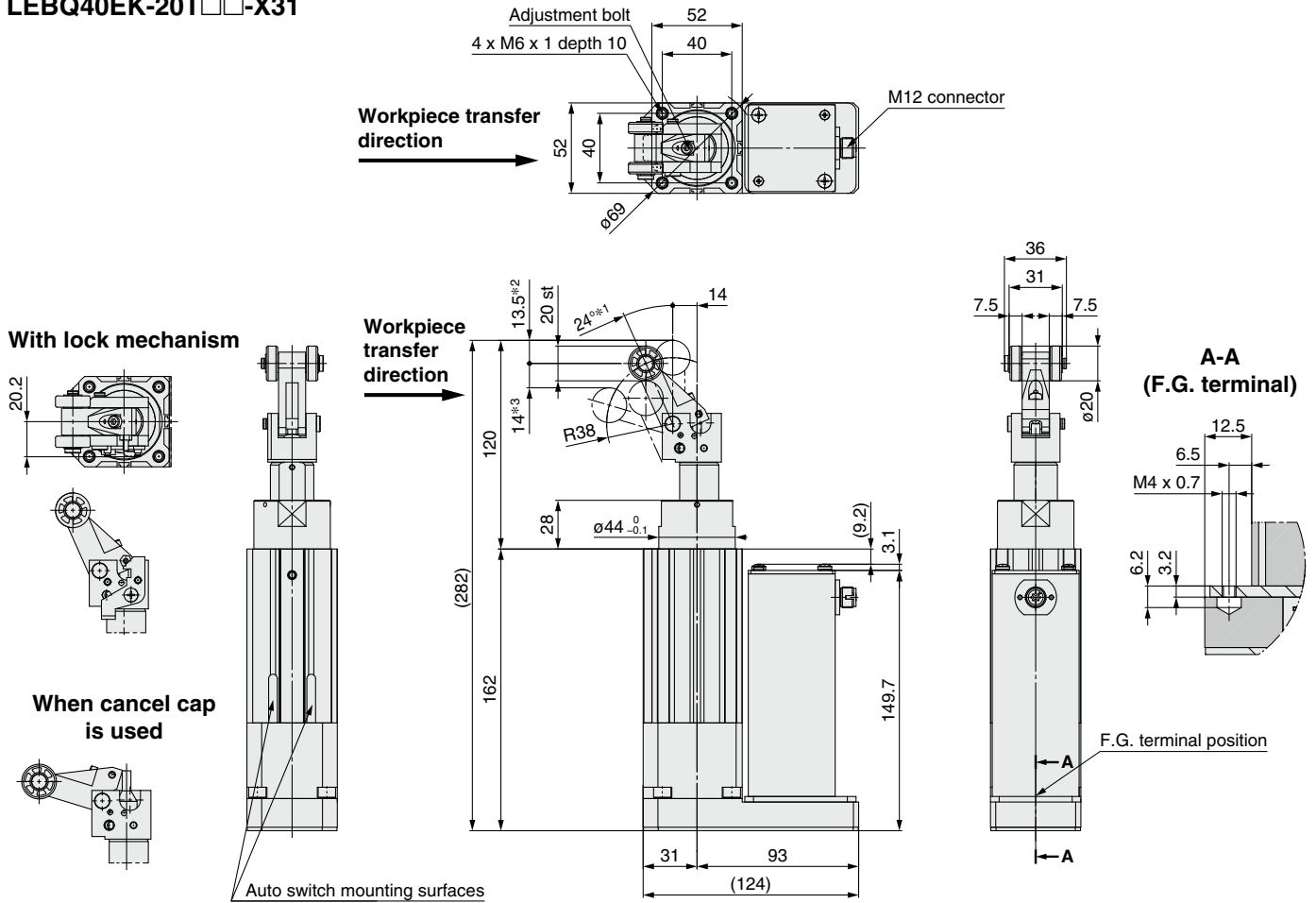

M12 connector

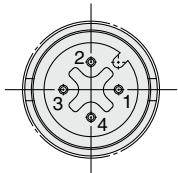

Connector specification

Pin No.	Description	Cable color*4	Function
1	—	—	Unused
2	—	—	
3	0V	Blue	Operating voltage
4	DC24V	Black	

*4 When an SMC cable is used
Cable part no.: **EX500-AP□□□□□**

■ The lever direction of this drawing is opposite the motor side: E type
■ The above drawing indicates the dimensions when the adjustment bolt is on the down end (when energy absorption is at its maximum)
Regarding the dimensions with * marking, the values changes as the adjustment bolt goes up.

*1 24° ⇒ 16° *2 13.5 ⇒ 11.5 *3 14 ⇒ 16

LEB□ Series Auto Switch Mounting

Auto Switch Mounting

<LEBQ40□-X31>

Auto switch proper mounting position (Detection at stroke end)

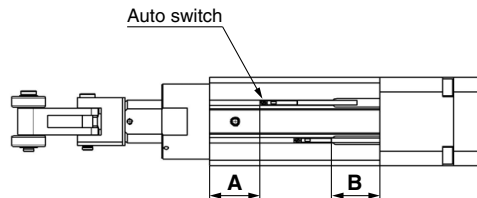

Auto Switch Proper Mounting Position

[mm]

Model	Auto switch model			
	D-M9□ D-M9□W		D-M9□V D-M9□WV	
	A	B	A	B
LEBQ40	29.6	28.4	29.6	30.4

* Adjust the auto switch after confirming the operating conditions in the actual setting

Mounting of Auto Switch

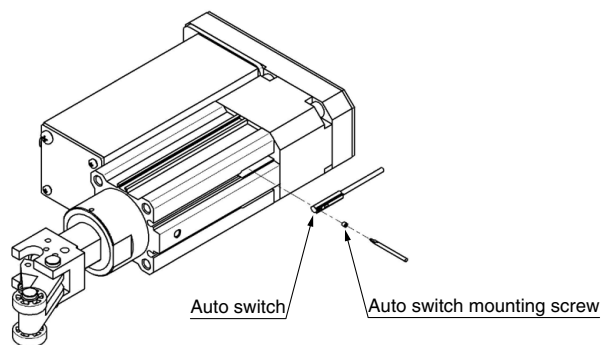

Tightening Torque for Auto Switch Mounting Screw [N·m]

Auto switch model	Tightening torque
D-M9□ D-M9□W D-M9□V D-M9□WV	0.05 to 0.15

* Tightening with a torque that exceeds the specified range may cause malfunction, while tightening with a torque below the range may cause misalignment of the gripping position, etc.

Operating Range

[mm]

Auto switch model	Model
	LEBQ40
D-M9□ D-M9□W D-M9□V D-M9□WV	5.5

* Values which include hysteresis are for reference purposes only.
They are not a guarantee (assuming approximately $\pm 30\%$ dispersion)
and may change substantially depending on the ambient environment.

LEBH□-X3 Series Model Selection

Operating Range

(Example)

Weight of transferred object: 300 kg
Transfer speed: 20 m/min
Friction coefficient: $\mu = 0.1$

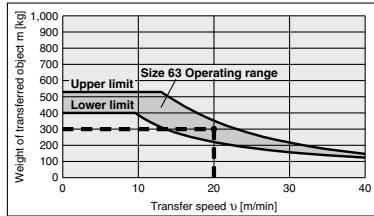

(How to read graph)

From the graph shown on the left side, find the intersection of the vertical axis representing the weight of 300 kg and the horizontal axis representing the transfer speed of 20 m/min. And select the size **63** positioned within the operating range of the cylinder.

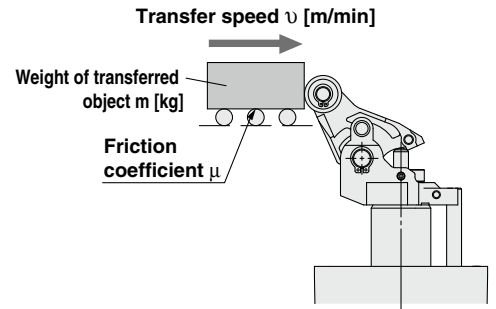

LEBH50□K-30T□-□-X3 * The graphs indicate the values at normal temperatures. (20 to 25°C)

$\mu = 0.1$

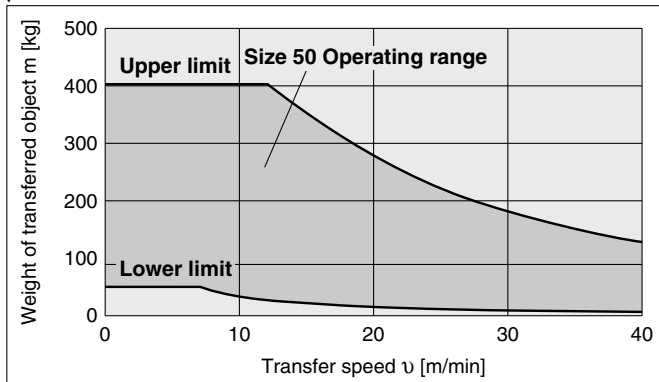

$\mu = 0.2$

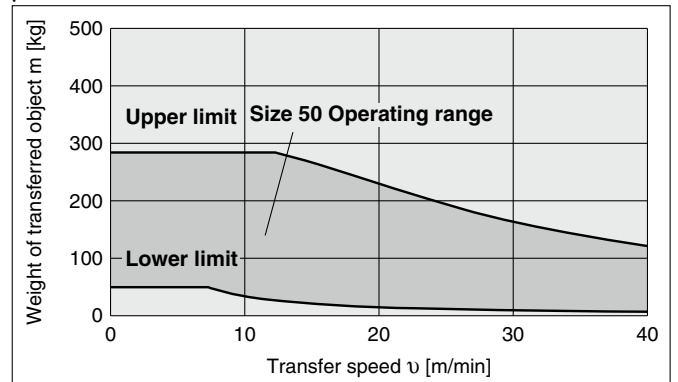

LEBH63□K-30T□-□-X3 * The graphs indicate the values at normal temperatures. (20 to 25°C)

$\mu = 0.1$

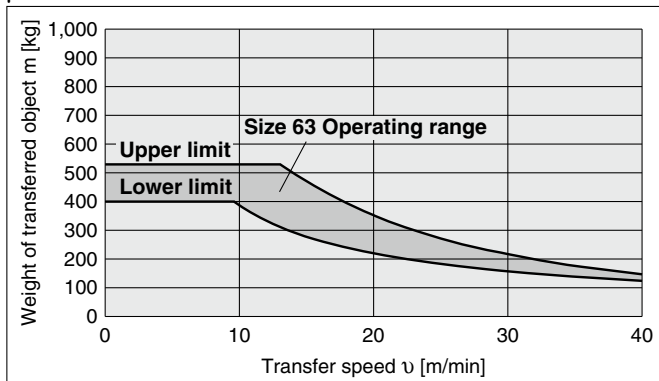

$\mu = 0.2$

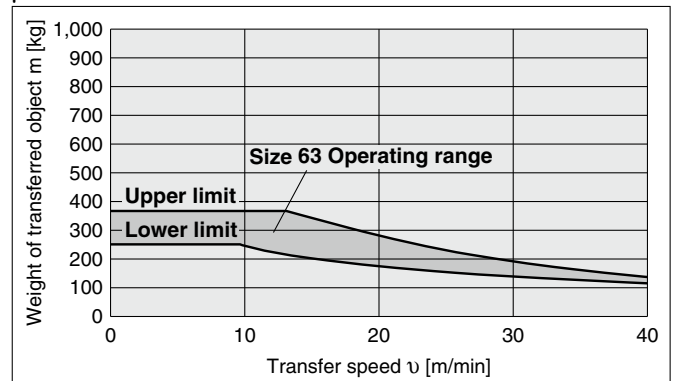

LEBH80□K-40T□-□-X3 * The graphs indicate the values at normal temperatures. (20 to 25°C)

$\mu = 0.1$

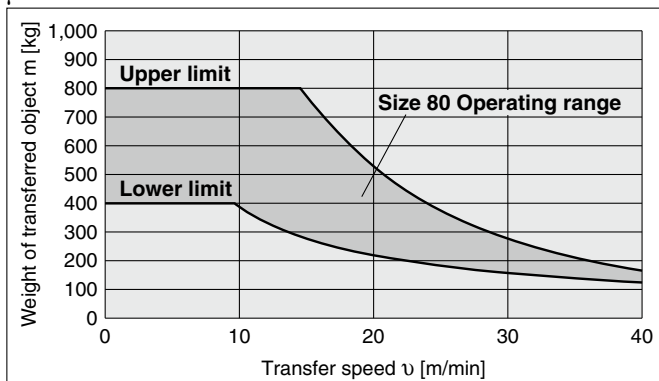

$\mu = 0.2$

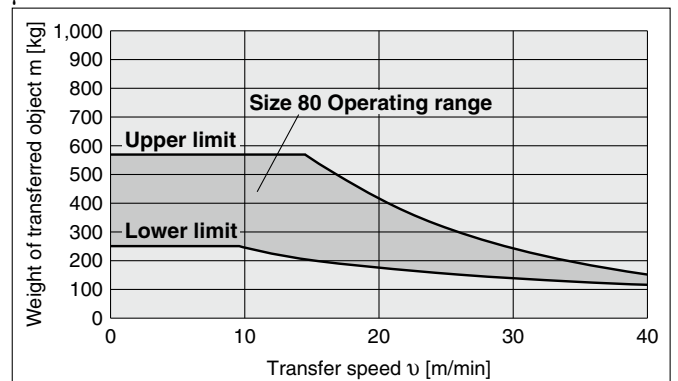

Electric Stopper Cylinder Controllerless Type



LEBH□-X3 Series

How to Order

LEBH **63** **E** **K** - **30** **T** **L** □ - □ - X3

①
②
③
④
⑤
⑥
⑦
⑧

① Size

50
63
80

② Lever direction

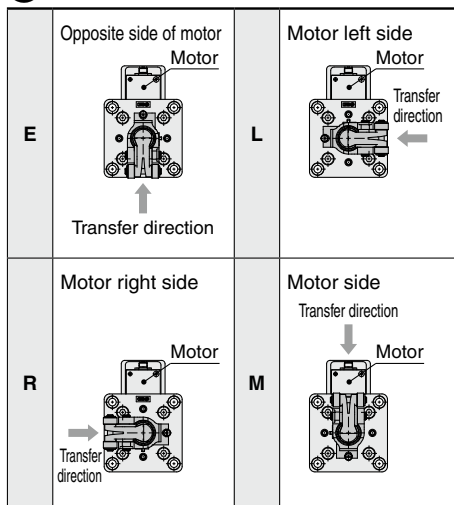

③ Lead

K	Basic
----------	-------

④ Stroke [mm]

30	50, 63
40	80

⑤ Action

T	Single acting/spring extend
----------	-----------------------------

⑥ Roller material

L	Resin
M	Carbon steel

⑦ Shock absorber

Nil	Standard
L	Low resistance

* Option "L" is only available for size 50.

⑧ Motor option

Nil	Without option
D	With lock mechanism
C	With cancel cap
S	With lever detection switch

*1 Options can be combined. Indicate the option symbols according to the priority order of D, C, S.

*2 Lever detection switch model: E2E-X2D1-N (OMRON)

Specifications

Model		LEBH50	LEBH63	LEBH80
Actuator specifications	Stroke [mm]	30		40
	Mounting orientation*3	Vertical (extending direction: top)		
	Rising (extending operation) time [sec]	1 or less		1.5 or less
	Descending (retracting operation) [sec]	1 or less (No lateral load)		1.5 or less (No lateral load)
	Action*1	Single acting/spring extend		
	Rod end configuration	Lever with built-in shock absorber		
	Actuation type	Ball screw + Belt		
	Operating frequency [c.p.m]	3 or less		
	Operating temperature range [°C]	5 to 40		
	Operating humidity range [%RH]	90 or less (No freezing)		
Product weight [kg]	3.8 (Without option)	5.5 (Without option)	9.3 (Without option)	
Replacement shock absorber part number	Shock absorber type: Nil (standard)	RS2H-R50	RS2H-R63	RS2H-R80
	Shock absorber type: L (low resistance)	RS2H-R50-X2464	—	—
Electric specifications	Motor size	ø38		ø55
	Motor type	DC motor		
	Rated voltage [V]	24 VDC ±10%		
	Starting power [W]	48		
	Holding power at lowered-end [W]*2	4.8		

- *1 This actuator holds the raised-end when de-energized. (Spring return)
- *2 This actuator holds the lowered-end with solenoid only when de-energized.
- *3 This actuator can be used in vertical directions only.
- * The motor will be turned OFF automatically by the internal circuit board after the actuator stops. A dedicated controller or driver is not necessary.
- * The applicable auto switch is the D-M9□ series.
(Please refer to the **Web Catalog** for details.)

- * A short break function is included with this cylinder for protection.
- * Short break function: a function that slows the driving motor down if the rotation speed is over the designated value.
- * Beware of inrush current of approx. 5 A when the power supply is turned on.
Choose the equipment used when the power supply is turned such as relay considering the inrush current.

Construction

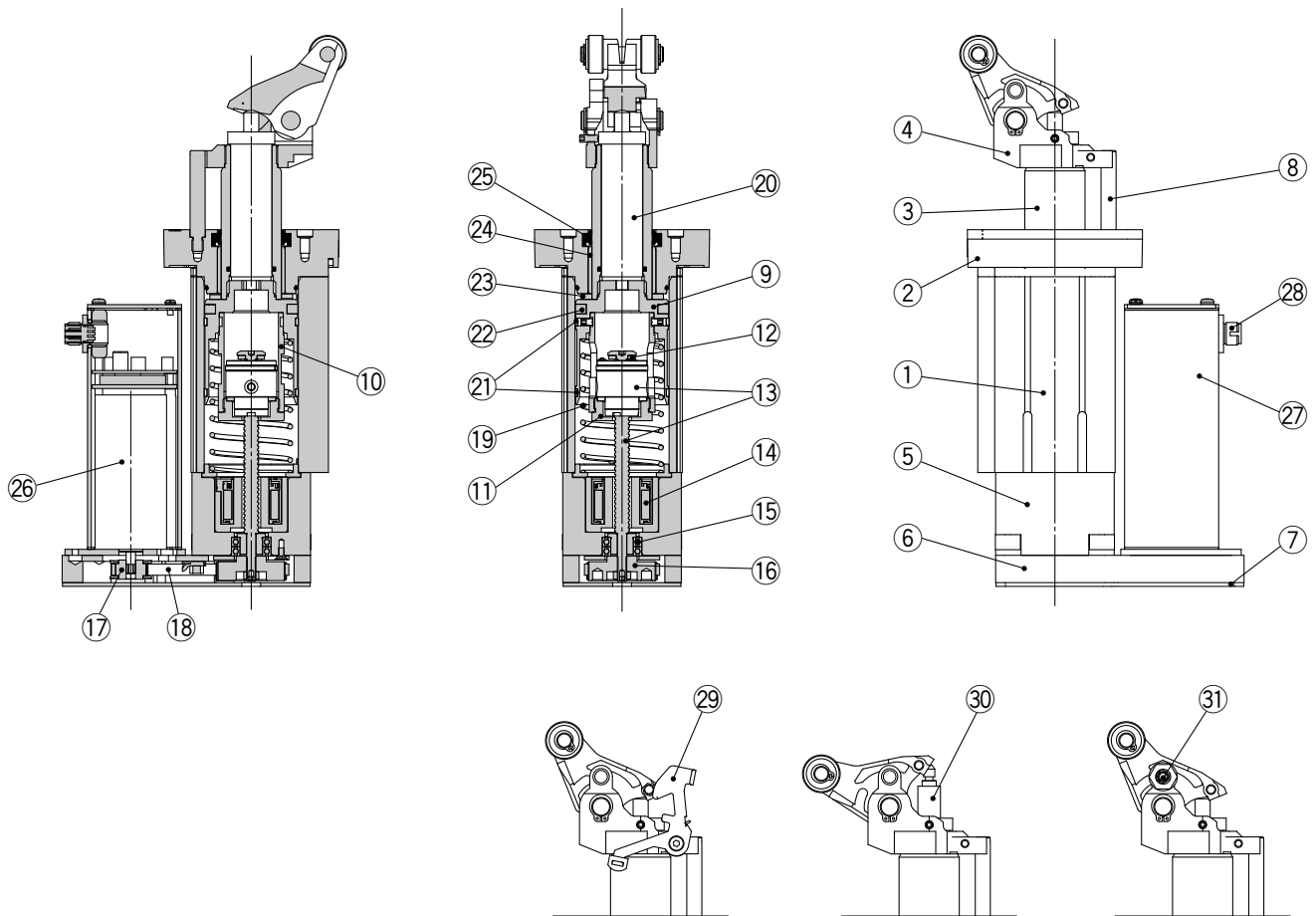

Component Parts

No.	Description	Material	Note
1	Cylinder tube	Aluminium alloy	Anodized
2	Rod cover	Aluminium alloy	
3	Piston rod	Carbon steel	Hard chrome plating
4	Lever holder assembly	—	
5	Housing	Aluminium alloy	Anodized
6	Return box	Aluminium alloy	Anodized
7	End plate	Aluminium alloy	Anodized
8	Guide rod	Carbon steel	Hard chrome plating
9	Piston	Aluminium alloy	Anodized
10	Piston tube	Aluminium alloy	Anodized
11	Piston cap	Carbon steel	Chromated
12	Urethane washers	Urethane	
13	Ball screw nut assembly	—	
14	Solenoid assembly	—	
15	Bearing	—	
16	Speed reduction pulley	Aluminium alloy	

No.	Description	Material	Note
17	Motor pulley	—	
18	Belt	—	
19	Spring	Steel wire	Chromated
20	Shock absorber	—	
21	Wear ring	Synthetic resin	
22	Plastic magnet	—	
23	Bumper	Synthetic resin	
24	Bushing	—	
25	Rod seal	—	
26	Motor	—	
27	Motor cover	Aluminum alloy	Anodized
28	Connector assembly	—	
29	Lock mechanism assembly	—	"With lock mechanism" only
30	Cancel cap assembly	—	"With cancel cap" only
31	Proximity switch	—	"With lever detection switch" only

LEBH□-X3 Series

Dimensions

LEBH50□K-30T□-□-X3

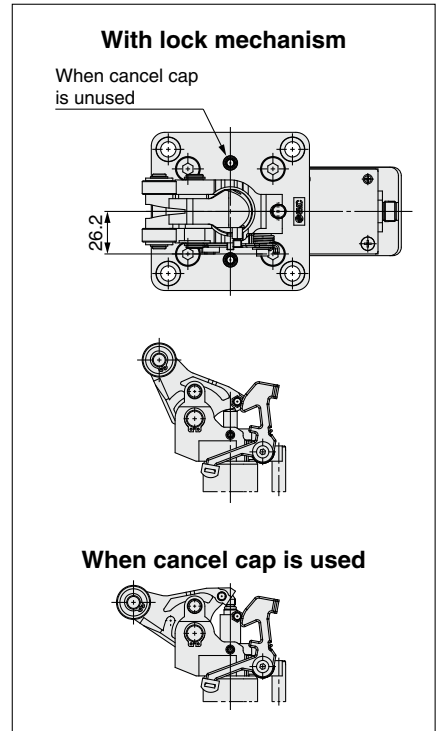
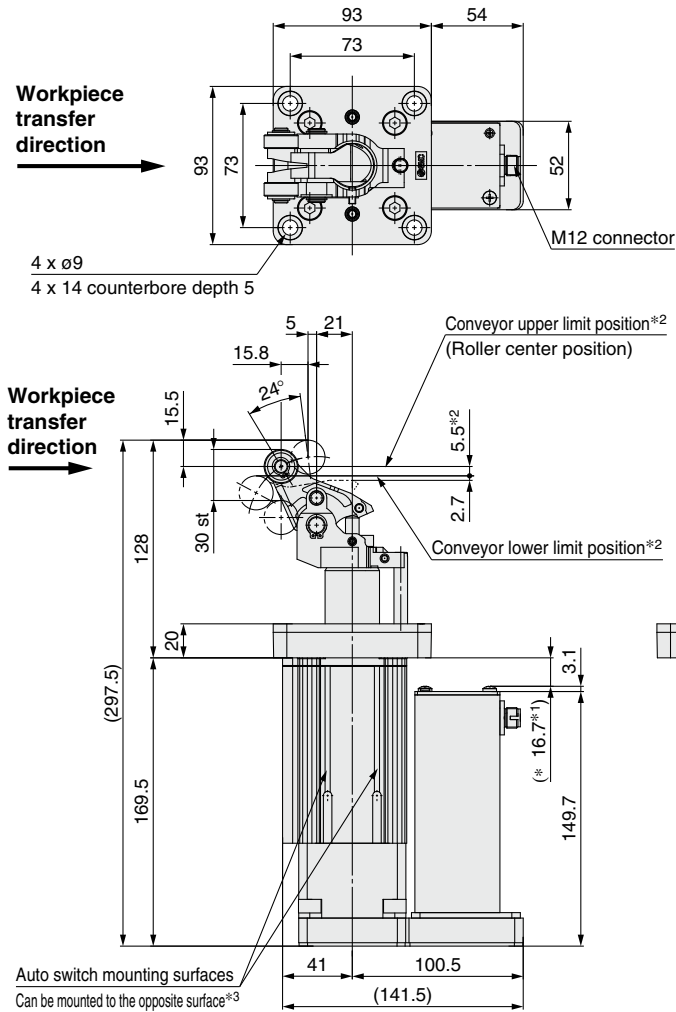

A-A (F.G. terminal)

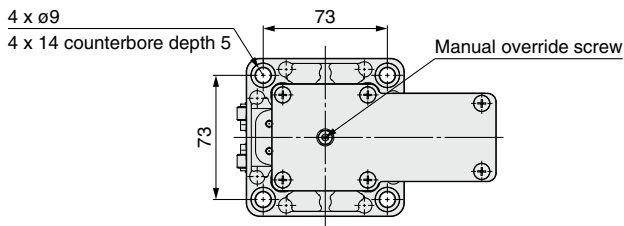
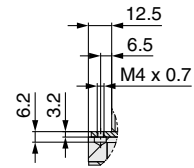

- *1 Please note that the thickness of a mounting plate should be 10 mm or less when this cylinder is mounted from the top (lever side) and ensure that the mounting plate does not interfere with the lever.
- *2 Please adjust the conveyor height within the range of the lower limit position to the upper limit position.
- *3 The auto switch mounting surface is indicated above regardless of lever direction.

Workpiece transfer direction

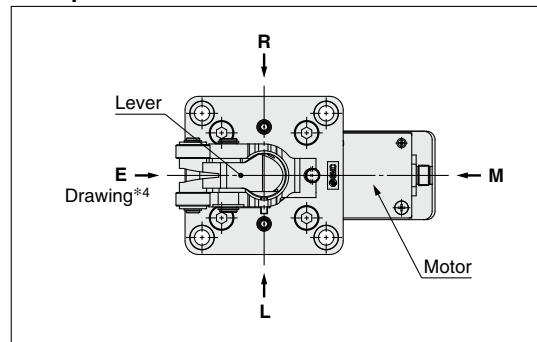

*4 Lever direction of this drawing is opposite the motor side: E type

M12 connector

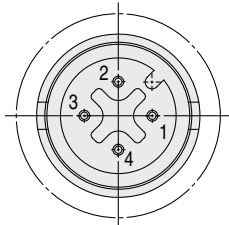

Connector specification

Pin No.	Description	Cable color*5	Function
1	—	—	Unused
2	—	—	Unused
3	0V	Blue	Operating voltage
4	DC24V	Black	Operating voltage

* When an SMC cable is used
Cable part no.: EX500-AP□□□□□

Dimensions

LEBH63□K-30T□-□-X3

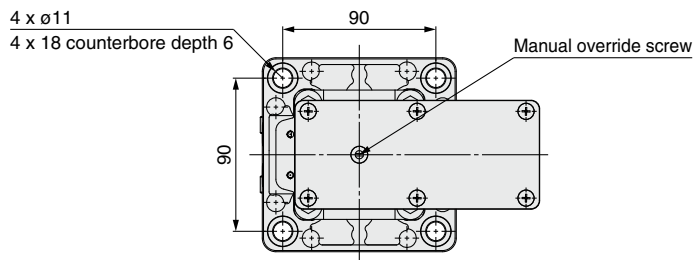
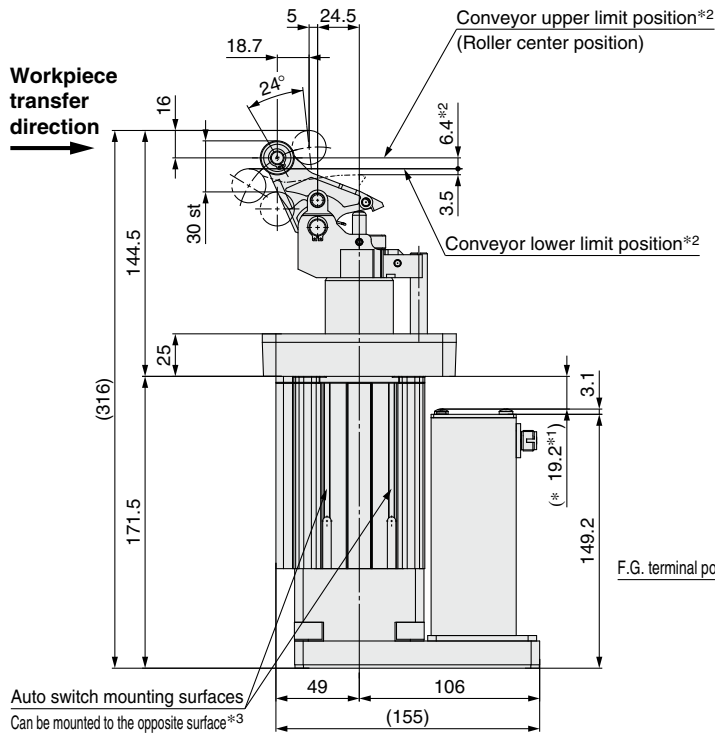
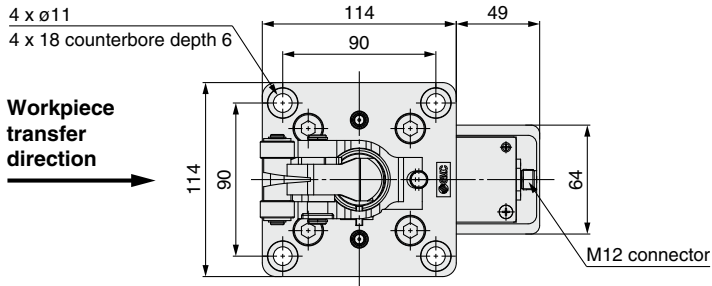

- *1 Please note that the thickness of a mounting plate should be 15 mm or less when this cylinder is mounted from the top (lever side) and ensure that the mounting plate does not interfere with the lever.
- *2 Please adjust the conveyor height within the range of the lower limit position to the upper limit position.
- *3 The auto switch mounting surface is indicated above regardless of lever direction.

M12 connector

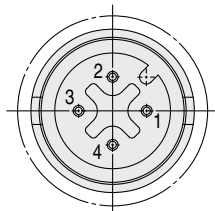

Connector specification

Pin No.	Description	Cable color*5	Function
1	—	—	Unused
2	—	—	
3	0V	Blue	Operating voltage
4	DC24V	Black	

* When an SMC cable is used
Cable part no.: EX500-AP□□□□

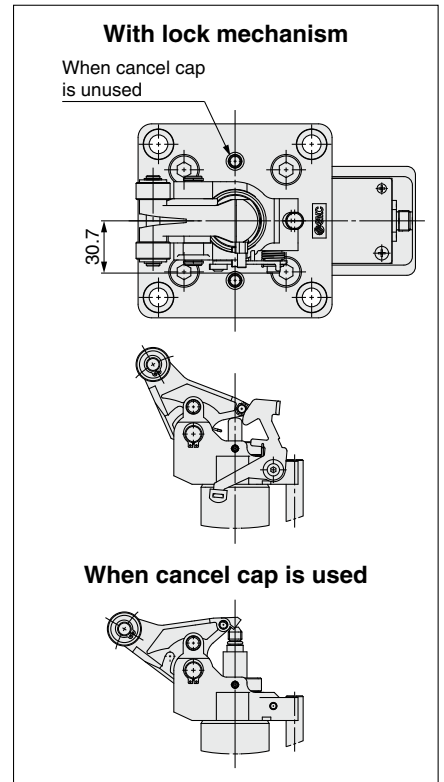

A-A (F.G. terminal)

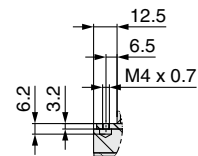

Workpiece transfer direction

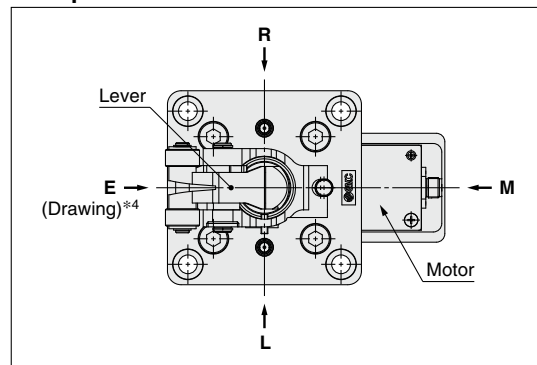

*4 Lever direction of this drawing is opposite the motor side: E type

LEBH□-X3 Series

Dimensions

LEBH80□K-40T□-□-X3

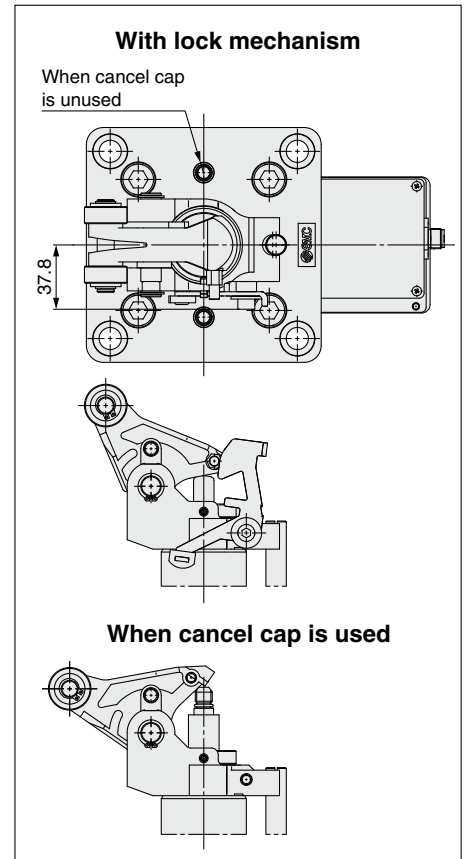
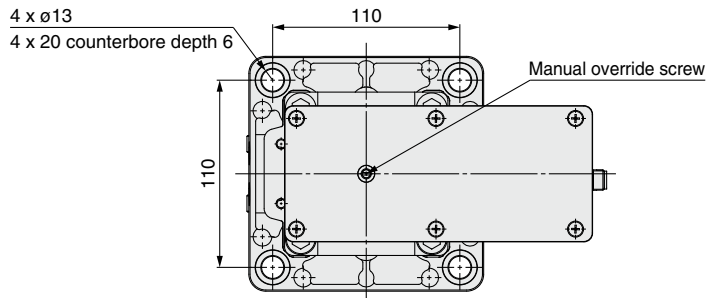
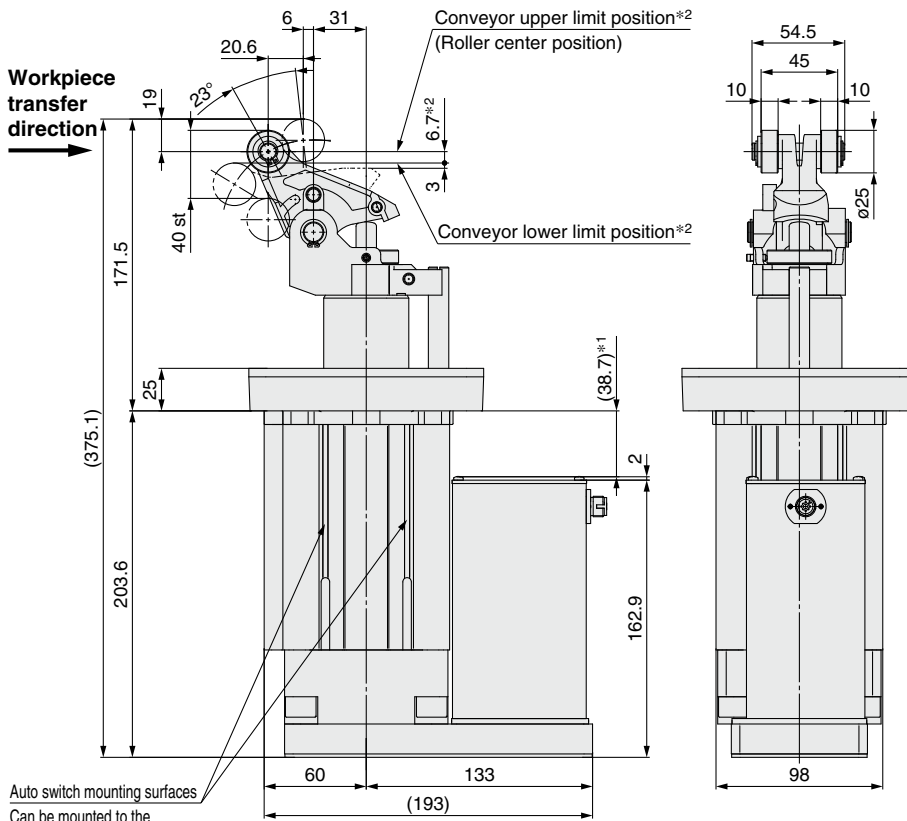
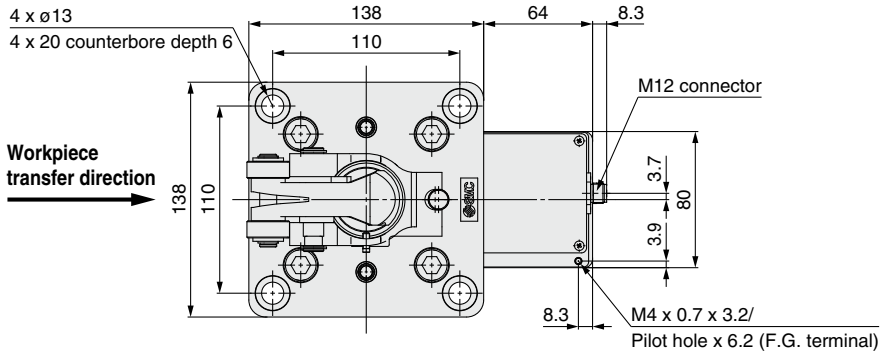

- *1 Please note that the thickness of a mounting plate should be 18 mm or less when this cylinder is mounted from the top (lever side) and ensure that the mounting plate does not interfere with the lever.
- *2 Please adjust the conveyor height within the range of the lower limit position to the upper limit position.
- *3 The auto switch mounting surface is indicated above regardless of lever direction.

Workpiece transfer direction

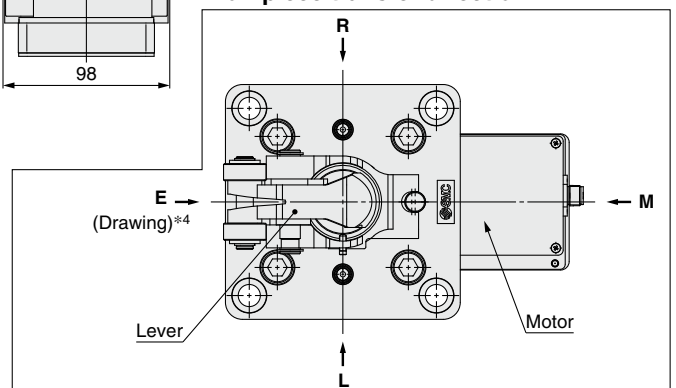

*4 Lever direction of this drawing is opposite the motor side: E type

M12 connector

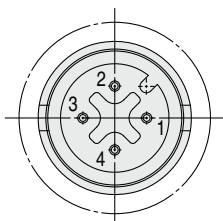

Connector specification

Pin No.	Description	Cable color*5	Function
1	—	—	Unused
2	—	—	
3	0V	Blue	Operating voltage
4	DC24V	Black	

*5 When an SMC cable is used
Cable part no.: EX500-AP□□□-□

Lever Detection Switch (Proximity Switch)/E2E-X2D1-N

Proximity Switch Specifications/ Manufactured by OMRON Corporation

Model	E2E-X2D1-N
Output type	Normally open
Power supply voltage (Operating voltage range)	12 to 24 VDC (10 to 30 VDC) Ripple 10% or less (P-P)
Current consumption (Leakage current)	0.8 mA or less
Response frequency	1.5 kHz
Control output (Chest)	3 to 100 mA
Indicator LED	Operation indication (Red LED), Set operation indication (Green LED)
Ambient temperature	-25 to 70°C (No freezing)
Operating ambient humidity	35 to 95%RH
Residual voltage *1	3 V or less
Withstand voltage *2	1000 VAC
Vibration	Endurance 10 to 55 Hz, Double amplitude 1.5 mm X, Y, Z direction each 2 h
Impact	Endurance 500 m/s ² (approx. 50 G), X, Y, Z direction each 10 times
Enclosure	IEC standards IP67 (Immersion proof and oil proof by JEM standards IP67G)

*1 At load current 100 mA and cord length of 2 m

*2 Between case and whole live part

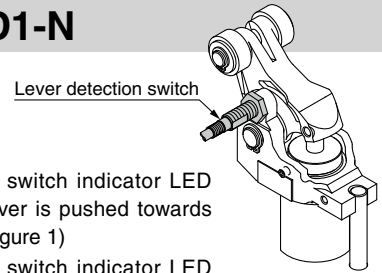

<Mounting position>

Confirm that the proximity switch indicator LED turns to green when the lever is pushed towards the proximity switch side. (Figure 1)

Confirm that the proximity switch indicator LED turns to green when the lever is pushed towards the opposite side from the proximity switch. (Figure 2)

Then, rotate the lever by 90° to confirm that the indicator LED of the proximity switch (red, green) does not turn on.

Fix the cylinder with screws included as accessories after confirming that there is no interference between the lever and the proximity switch.

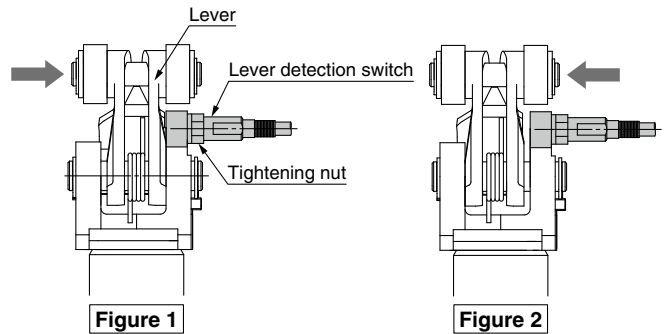

Dimensions

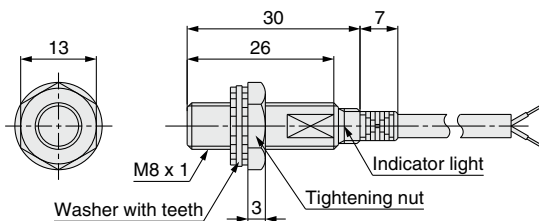

* Vinyl insulation round cord
ø3.5 (18/ø0.12) 2-core, standard 2 m, cord extension (individual metal piping) max. 200 m

Output Circuit

2-Wire

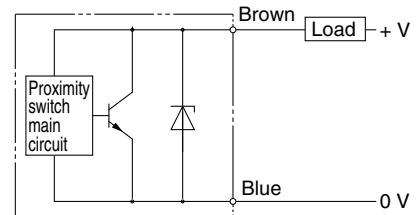

Auto Switch Mounting

Auto switch proper mounting position (Detection at Stroke End)

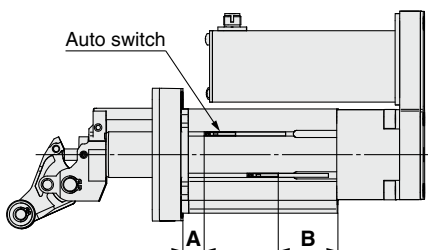

Auto switch proper mounting position [mm]

Model	Auto switch model			
	D-M9□		D-M9□V	
	A	B	A	B
LEBH50	16.1	40.9	16.1	42.9
LEBH63	15.6	45.4	15.6	47.4
LEBH80	27.1	51.2	27.1	53.2

* Adjust the auto switch after confirming the operating conditions in the actual setting

Mounting of auto switch

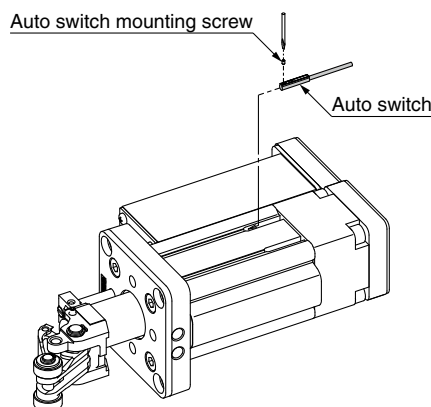

• When tightening an auto switch mounting screw, use a watchmaker's screwdriver with a grip diameter of 5 to 6 mm.

Tightening Torque for Auto Switch Mounting Screw [N·m]

Auto switch model	Tightening torque
D-M9□ D-M9□W D-M9□V D-M9□WV	0.05 to 0.15

Operating Range [N·m]

Auto switch model	Model		
	LEBH50	LEBH63	LEBH80
D-M9□ D-M9□W D-M9□V D-M9□WV	6	6.5	7

* Since the operating range is provided as a guideline including hysteresis, it cannot be guaranteed. (assuming approximately ±30% dispersion)
It may vary substantially depending on an ambient environment.



LEB□ Series

Specific Product Precautions 1

Be sure to read this before handling the products. For safety instructions, electric actuator precautions, and auto switch precautions, refer to the “Handling Precautions for SMC Products” and the “Operation Manual” on the SMC website: <https://www.smcworld.com>

Design / Selection

⚠ Caution

1. Do not allow collision with the transferred object while the lever is up.

For the lever with a built-in shock absorber, do not allow collision with the next transferred object while the lever is up. Otherwise, all energy will be applied to the cylinder body.

2. When stopping a load directly connected to the cylinder at an intermediate position:

Apply the operating range in the catalog only in these cases where the stopper cylinder is used to stop pallets on a conveyor belt. When using the electric stopper cylinder to stop loads directly connected to a cylinder or some other equipment, a lateral load is applied as the cylinder thrust. Please consult SMC in such cases.

3. After the transferred object is stopped by the electric stopper, lateral load (conveyor load) must not be applied during the rod retraction operation.

Mounting

⚠ Caution

1. Do not apply rotational torque to the actuator rod.

To prevent rotational torque from being applied to the actuator rod, make sure that the lever contact surface is parallel to the transferred object contact surface.

Mounting

⚠ Caution

2. Recommended mounting plate and drilling

<LEBQ Series>

When mounting the lever type with a built-in shock absorber from the lever direction, refer to the recommended hole sizes in the table below and machine the mounting holes accordingly.

When mounting the stopper cylinder by inserting it into the mounting holes from the lever direction as shown in the figure below, note that the outer diameter (O.D.) of the lever part is larger than the diameter of the rod cover boss part.

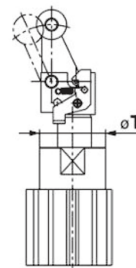
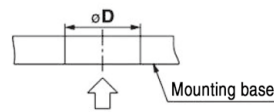

(Figure 1)

Table 1 Recommended hole size

Model	Rod cover boss outer diameter	Mounting base recommended hole size
	ϕT	ϕD
LEBQ32	36	38
LEBQ40	44	48
LEBQ50	56	57

<LEBH Series>

Secure the motor runoff space, and tighten the mounting screws within the specified torque range.

Tightening the screws with a higher torque than recommended may result in a malfunction, while tightening with a lower torque can result in the displacement of the mounting position.

LEBH50

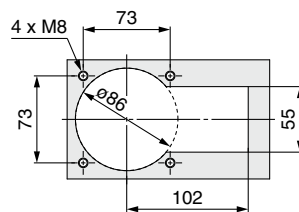

LEBH63

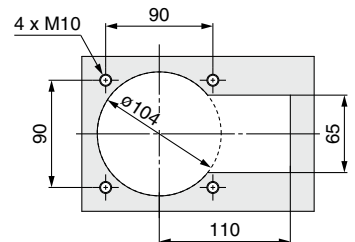

LEBH80

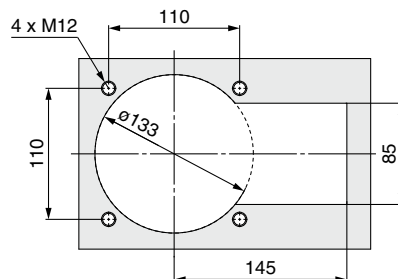

Model	Screw size	Max. tightening torque [N·m]
LEBH50	M8	12.5
LEBH63	M10	24.5
LEBH80	M12	42.0



LEB□ Series

Specific Product Precautions 2

Be sure to read this before handling the products. For safety instructions, electric actuator precautions, and auto switch precautions, refer to the “Handling Precautions for SMC Products” and the “Operation Manual” on the SMC website: <https://www.smcworld.com>

Mounting

⚠ Caution

3. How to change the direction of the piston rod

<LEBQ Series>

- Loosen the 2 hexagon socket head set screws (M3) for mounting the non-rotating guide in the rod cover part.
- Reposition the piston rod into the desired position.
 - To prevent rotational torque from being applied to the piston rod, make sure that the cylinder contact surface is parallel to the pallet contact surface.
- Tighten the 2 hexagon socket head set screws to secure the non-rotating guide. When tightening, apply screw-locking adhesive to the hexagon socket head set screws. Tightening torque: 0.63 N·m
 - The non-rotating guide is secured with 2 hexagon socket head set screws.
 - If 1 of the screws is overtightened, the non-rotating guide may come into contact with the piston rod, resulting in a malfunction. Therefore, tighten the hexagon socket head set screws alternately to prevent such contact.
- Make sure that the cylinder operates smoothly.

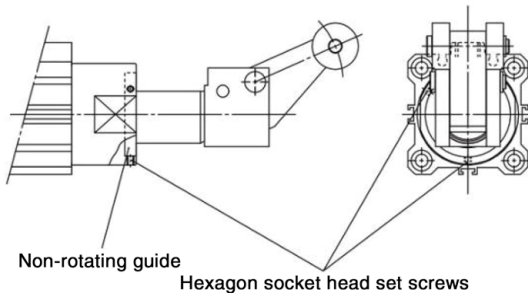

<LEBH Series>

Apply a wrench, etc., to the width across flats of the guide rod end to remove the guide rod. The lever part is able to rotate freely, and the direction can be changed in 90° increments (4 directions).

When mounting the guide rod, apply screw-locking adhesive to guide rod threaded part and tighten it.

- Guide rod (M6) tightening torque: 5.2 [N·m]

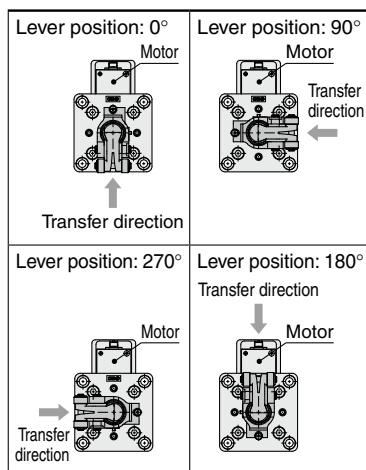
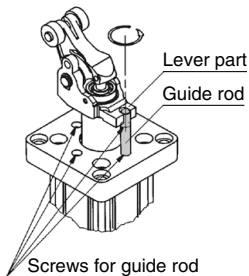

Handling

⚠ Caution

1. Do not let water, cutting oil or dust splash on the equipment.

It can cause oil leakage and malfunction of the shock absorber

2. How to adjust the lever type (with shock absorber adjustment) (LEBQ series)

The lever type (with shock absorber adjustment) can be adjusted via the shock absorber adjustment bolt in order to perform stops according to the conveyance conditions. Follow the adjustment procedure below.

Procedure

- Loosen the set screw (M4) on the side of the lever.
 - Adjust the adjustment bolt according to the energy of the transferred object.

(When the adjustment bolt is tightened, the shock absorber's stroke increases (absorbed energy increases), and when it is loosened, the stroke decreases (absorbed energy decreases).)
 - After adjusting the adjustment bolt, secure it with the set screw (M4) loosened in 1).
- Tightening torque M4: 1.5 N·m

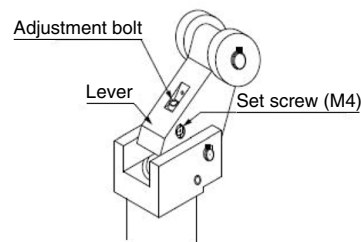

3. Shock absorber capacity variable adjustment method (LEBH series)

To stop the work gently, loosen the set screw (M4) on the stopper and turn the adjustment dial according to the energy value of the transferred object to select the optimum absorption position (retardation value).

For the adjustment dial, rotation to the right decreases the resistance value, and rotation to the left increases the resistance value. After adjustment, securely tighten the set screw to secure the adjustment dial in place. When reassembling, apply screw-locking adhesive to the threaded part and tighten it.

- Set screw (M4) tightening torque: 1.5 [N·m]

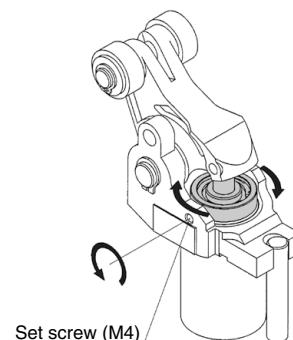



LEB□ Series

Specific Product Precautions 3

Be sure to read this before handling the products. For safety instructions, electric actuator precautions, and auto switch precautions, refer to the “Handling Precautions for SMC Products” and the “Operation Manual” on the SMC website: <https://www.smcworld.com>

Handling

⚠ Caution

4. When adjusting the shock absorber resistive force value, first try the maximum value and then proceed to smaller values (LEBH series)

If the energy value of the transferred object is higher than the resistance value of the shock absorber, this will stress the lever part, resulting in damage. At the time of factory shipment, the shock absorber resistance is set to the max. value.

5. For a cylinder with lock mechanism, do not apply an external force from the opposite side when the lever is locked.

Lower this actuator before adjusting the conveyor or moving a transferred object.

6. For a cylinder with lock mechanism, do not collide the transferred object and the roller when the lever is locked.

If the pallet collides with the roller in the locked state, it may cause lever malfunction. (The lever is released when this actuator is fully retracted.)

7. For the lever type with a lock mechanism rod end shape, do not remove the grease that has been applied to pin B and the bracket.

When using the cylinder continuously with no grease applied, the lock and unlock may not operate correctly due to unusual wear of the lock pin. Check the grease application state periodically and apply the grease when necessary.

* Grease pack part no.: GR-S-010 (10g)

Similarly, be careful not to remove the grease from the piston rod end of the built-in shock absorber. Check the grease application state periodically.

<LEBQ Series>

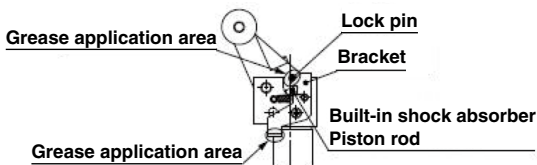

<LEBH Series>

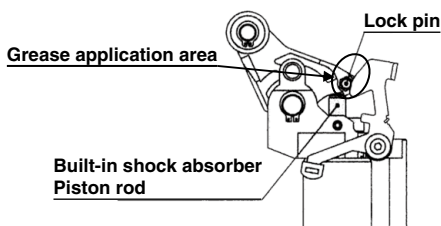

Maintenance

⚠ Caution

1. The stopping condition of the transferred object may vary due to changes in ambient temperature or changes in the shock absorber resistance over time.

2. How to replace the shock absorber <LEBQ Series>

1) Loosen the hexagon socket head set screw (M3) on the piston rod part.

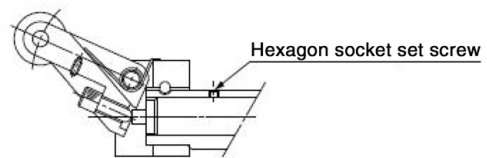

2) With the lever tilted as shown, pull out the shock absorber to remove it, and replace it with a new shock absorber.

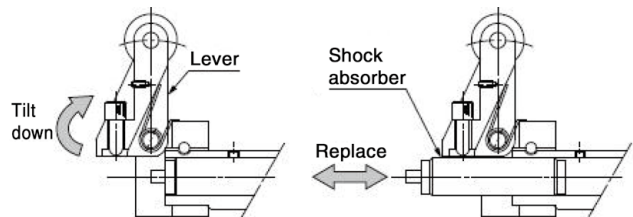

3) Tighten the hexagon socket head set screw to the piston rod part. After the hexagon socket head set screw stops, turn it a further 1/4 rotation. Overtightening the hexagon socket head set screw may damage it, and the shock absorber may also malfunction as a result.

Tightening torque: 0.29 N·m

4) After replacement, apply grease to the shock absorber piston rod end.

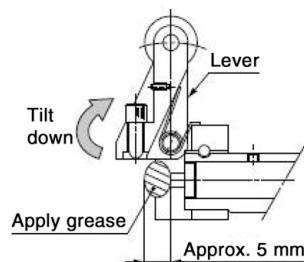



LEB□ Series

Specific Product Precautions 4

Be sure to read this before handling the products. For safety instructions, electric actuator precautions, and auto switch precautions, refer to the “Handling Precautions for SMC Products” and the “Operation Manual” on the SMC website: <https://www.smcworld.com>

Maintenance

⚠ Caution

<LEBH Series>

Loosen the set screw (M4) for shock absorber mounting provided in the lever holder, tilt the lever 90°, and pull out the shock absorber.

After replacing the shock absorber, tighten the set screw firmly and apply grease to the shock absorber rod end surface.

* Set screw (M4) tightening torque: 1.5 [N·m]

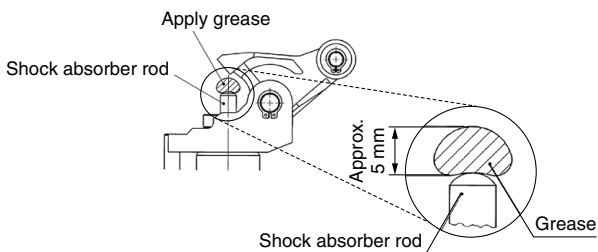
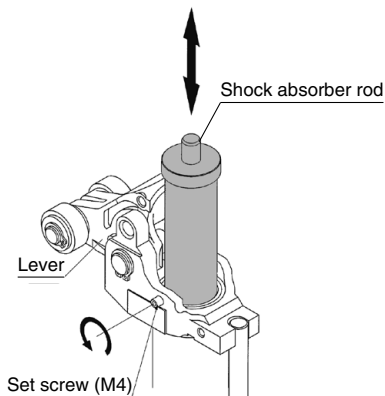

 **Safety Instructions** | Be sure to read the "Handling Precautions for SMC Products" (M-E03-3) and "Operation Manual" before use.

SMC Corporation

Akihabara UDX 15F,
4-14-1, Sotokanda, Chiyoda-ku, Tokyo 101-0021, JAPAN
Phone: 03-5207-8249 Fax: 03-5298-5362
<https://www.smcworld.com>
© 2024 SMC Corporation All Rights Reserved

Specifications are subject to change without prior notice
and any obligation on the part of the manufacturer.

D-G