

Liquid Collector Exhaust Pressure Type **AEP100-02**



AL800
AL900
ALF
ALT
ALD
ALB
LMU
ALIP
AEP
HEP

Resource Saving/Energy Saving/Labor Saving

Uses exhaust pressure to collect and reuse leaked lubricant and hydraulic fluid

Resource Saving/Collects leaked lubricant and hydraulic fluid

These collectors help prevent waste by collecting valuable hydraulic fluid and lubricant that has leaked and built up in the vicinity of the machinery.

Energy Saving/Driven by exhaust pressure

These collectors save energy by employing the exhaust air from the switching valve, which would otherwise be simply released into the atmosphere.

Labor Saving/No need for workers to collect fluid

These collectors contribute to efficiency by eliminating the need for workers to carry out tasks such as collecting fluid and wiping down machinery.

Specifications

Model	AEP100-02
Collected fluid	Hydraulic fluid/Lubricant
Fluid	Air
Operating pressure	200 to 700 kPa (0.2 to 0.7 MPa)
Fluid temperature	5 to 60°C
Collected fluid temperature	5 to 60°C
Collected fluid discharge volume	10 mL/one time (at 0.5 MPa)
Collected fluid lifting range	8 m (at 0.5 MPa)
Exhaust port effective area	21 mm ² <Cv1.1>
Port size	3-PT 1/4
Filtration	40 mesh (Gauze)
Weight	0.8 kg

AEP100-02

Operating Conditions

Cylinder	Bore size	40 mm or more
	Stroke	100 mm or more
	Piston speed	100 mm/s or more
Tubing length on IN side	ø6 / ø4	10 m or less
	ø8 / ø6	5 m or less

Circuit Example

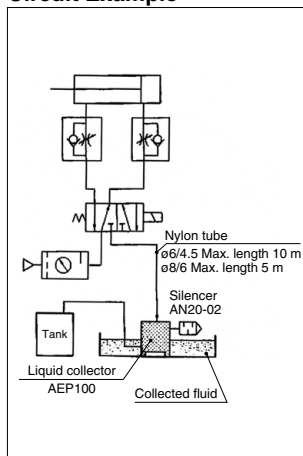

Handling Precautions

Mounting

- Mount with the exhaust pressure IN side facing up. Mounting on a slant may result in the check valve malfunctioning.
- Select the exhaust port side that does not require an air cylinder speed control.
- Mount a silencer (AN20-02) on the exhaust port of the AEP100 to prevent the intrusion of dust from outside.

Collected fluid

- Avoid collecting spindle fluid or other corrosive fluids.

During use

- When there is no discharge of collected fluids, carry out priming from the OUT port. (This replenishes the collected fluids.)
- Severe clogging of the gauze may result in abnormally reducing discharge volume. At such times, remove the gauze and clean it.

Working Principle

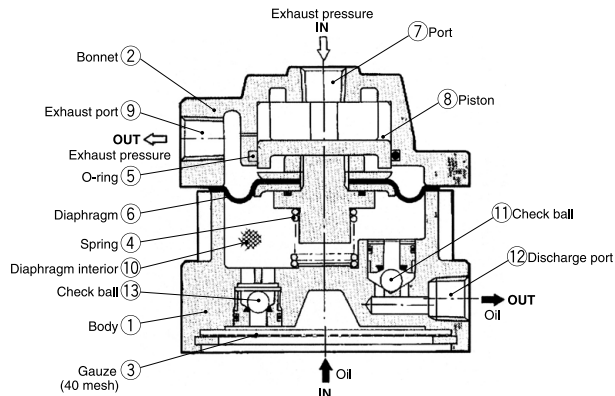

When the exhaust pressure from the switching valve enters into port ⑦, the piston ⑧ and diaphragm ⑥ compress and displace spring ④, the exhaust pressure is released into the atmosphere from exhaust port ⑨, and at the same time the diaphragm is returned to its original condition by the recovery power of the spring. At this time, the diaphragm interior ⑩ is under negative pressure, causing the check ball ⑪ to be closed while check ball ⑬ is open, and causing built-up oil outside to enter into the diaphragm interior. When exhaust pressure once again enters, operation of the piston and diaphragm causes the diaphragm to be compressed, and check ball ⑪ opens, causing the oil in the diaphragm interior to be discharged from discharge port ⑫.

Main Parts

No.	Description	Material	Note
1	Body	ADC12	Chromate treated
2	Bonnet	ADC12	Chromate treated
3	Gauze	Stainless steel 304	

Parts List

No.	Description	Material	Note
4	Spring	Stainless steel 304	180111
5	O-ring	NBR	JISB2401 P-40
6	Diaphragm assembly	—	180110A

Dimensions

