

Mist Separator

Series AM

Series AM can separate and remove oil mist in compressed air which is difficult to remove by ordinary air filters and remove solid particles such as rust or carbon of more than 0.3 μm. It is the most suitable for air sources that drive pilot, metal seal solenoid valves.

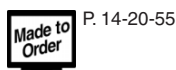
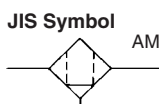

Model

Model	AM150	AM250	AM350	AM450	AM550	AM650	AM850
Rated flow (ℓ/min (ANR)) ^{Note)}	300	750	1500	2200	3500	6000	12000
Port size (Nominal size B)	1/8, 1/4, 3/8	1/4, 3/8, 1/2	3/8, 1/2, 3/4	1/2, 3/4, 1	3/4, 1	1, 1 1/2	1 1/2, 2
Weight (kg)	0.38	0.55	0.9	1.4	2.1	4.2	10.5



Note) Max. flow capacity at a pressure of 0.7 MPa. Max. flow varies depending on operating pressure. Refer to "Flow Characteristics" (page 14-20-17) and figure of "Max. Air Flow" (page 14-20-18).



Note) Refer to "Made to Order Specifications" on page 14-20-57 for large flow capacity type of AM850 or more.

Specifications

Fluid	Compressed air
Max. operating pressure	1.0 MPa
Min. operating pressure ⁽¹⁾	0.05 MPa
Proof pressure	1.5 MPa
Ambient and fluid temperature	5 to 60°C
Filtration	0.3 μm (95% particle size collection)
Oil mist removal rate	Max. 1.0 mg/m ³ (ANR) (≒0.8 ppm) ⁽²⁾
Element life	2 years or when pressure drop reaches 0.1 MPa

Note 1) 0.1 MPa (N.O. type) or 0.15 MPa (N.C. type) in the case of types with auto-drain.

Note 2) At oil mist density of 30 mg/m³ (ANR) is blown out by compressor

Refer to "Made to Order Specifications" on page 14-20-55.

Accessory (Option)

Applicable model	AM150	AM250	AM350	AM450	AM550	AM650	AM850
Bracket assembly (With cap bolt and spring washer)	BM51	BM52	BM53	BM54	BM55	BM56	BM57

Caution

Be sure to read before handling. Refer to pages 14-21-3 to 4 for Safety Instructions and Common Precautions on the products mentioned in this catalog, pages 14-14-6 to 8 for Precautions on every series, and pages 14-20-62 to 64 for more detailed precautions on every series.

How to Order

AM 250 03 B J

Body size

150	1/8 Standard
250	1/4 Standard
350	3/8 Standard
450	1/2 Standard
550	3/4 Standard
650	1 Standard
850	1 1/2 Standard

Thread type

Nil	Rc
F	G
N	NPT

Port size

01	1/8 ^B	06	3/4 ^B
02	1/4 ^B	10	1 ^B
03	3/8 ^B	14	1 1/2 ^B
04	1/2 ^B	20	2 ^B

Option

J	Drain guide 1/4 ^B female thread
R	IN-OUT reversal direction
T	Element service indicator

Accessory (Option) *

Symbol	Description
Nil	—
B	Bracket
C	N.C. auto-drain
D	N.O. auto-drain

* Refer to the table below for accessory/Option combinations.



Note) Refer to "How to Order Bowl Assembly" on page 14-20-59.

Accessory/Option Combinations

○ Available ■ Not available ○ Depends on model

Accessory (Option)	Accessory	Option specifications				Applicable model								
		C	D	J	R	T	AM150	AM250	AM350	AM450	AM550	AM650	AM850	
Accessory	N.C. auto-drain	C												
	N.O. auto-drain	D												
Option	Drain guide 1/4 ^B	-J												
	IN-OUT reversal direction	-R												
	Element service indicator	-T												

Flow Characteristics

Element oil saturation



Note) Compressed air over max. flow line in the table below may not meet the specifications of the product. It may cause damage to the element.

AM150

1/8^B

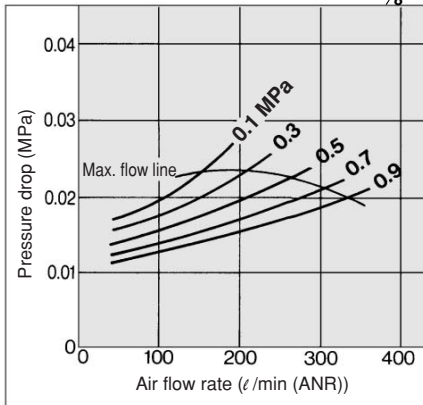

AM450

1/2^B

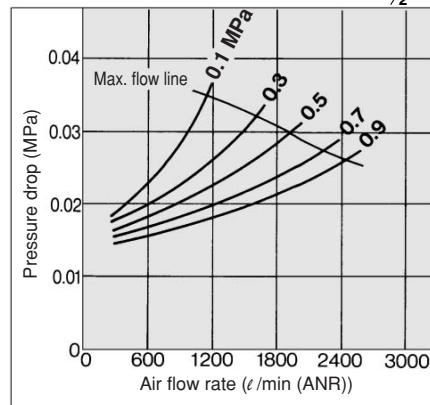

AM850

1 1/2^B

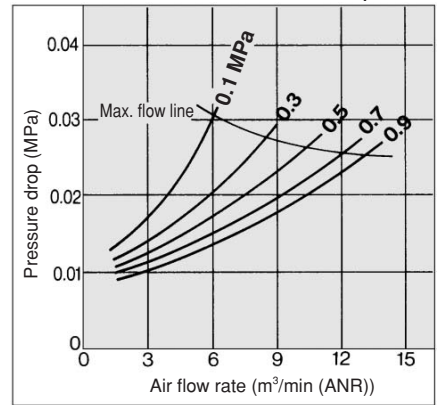

AM250

1/4^B

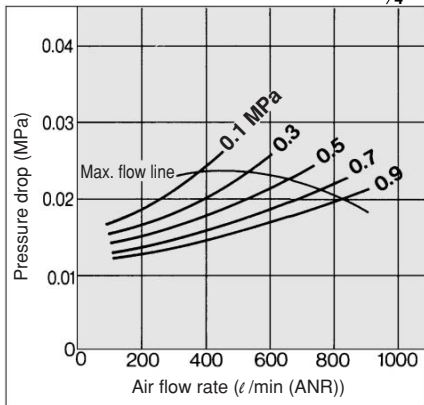

AM550

3/4^B

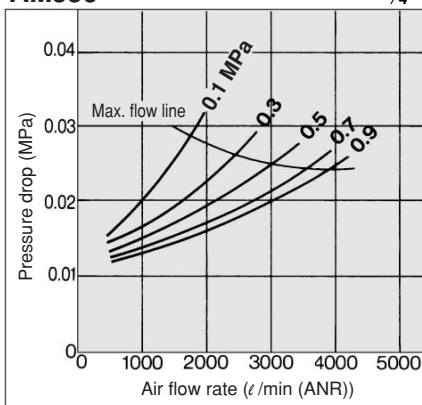

AM350

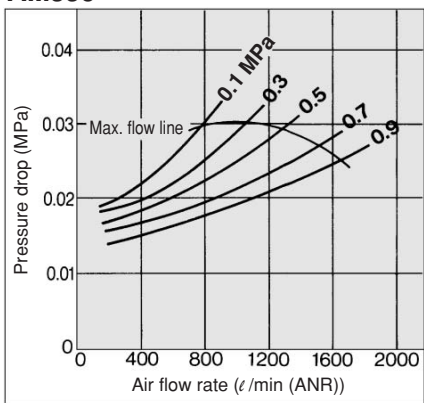

AM650

1^B

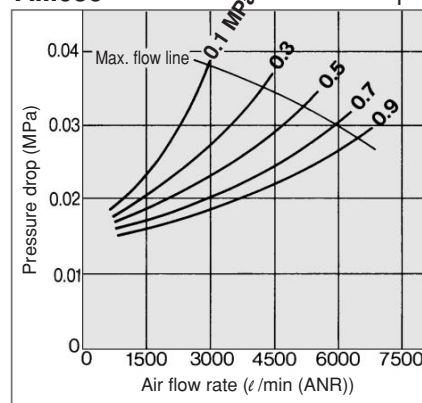

HA

AT

ID

AMG

AFF

AM

Misc.

Series AM

Construction

AM150 to AM550

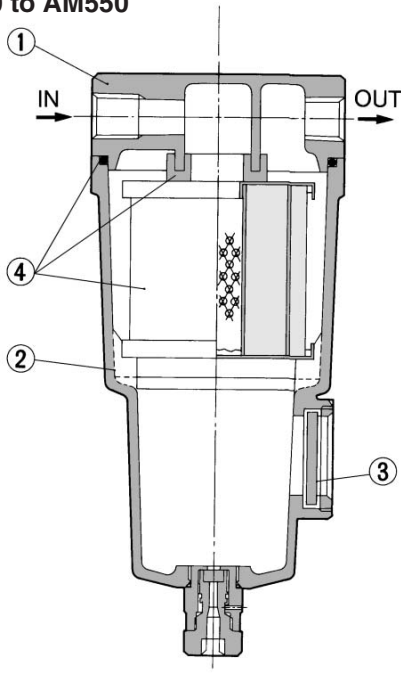

AM650 to AM850

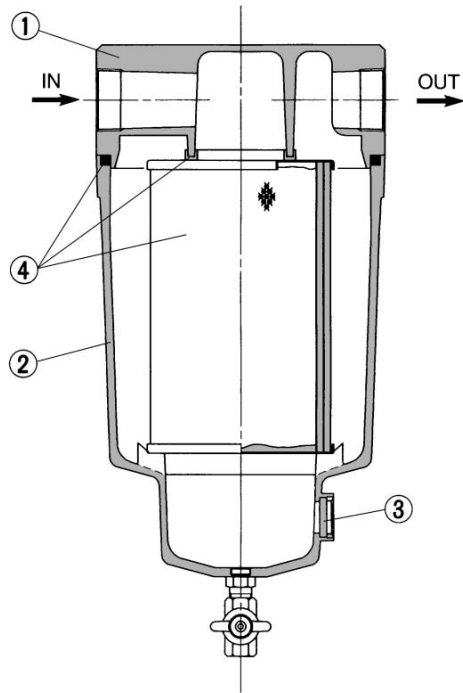

Component Parts

No.	Description	Material	Note
①	Body	Aluminum die-casted	Chrome treated
②	Housing	Aluminum die-casted*	Epoxy coating on inner surface
③	Sight glass	Tempered glass	

* AM850 is aluminum casted.

Replacement Parts

No.	Description	Material	Model						
			AM150	AM250	AM350	AM450	AM550	AM650	AM850
④	Element assembly	Glass fiber, Others	AM-EL150	AM-EL250	AM-EL350	AM-EL450	AM-EL550	AM-EL650	AM-EL850

* Element assembly : With gasket and O-ring



Note) Refer to page 14-20-59 for "How to Order Bowl Assembly".



Note) Sight glass is indicated in the figure above for easy understanding of parts, however mounting position is different. Refer to dimensions on pages 14-20-19 to 14-20-20 for details.

Max. Air Flow

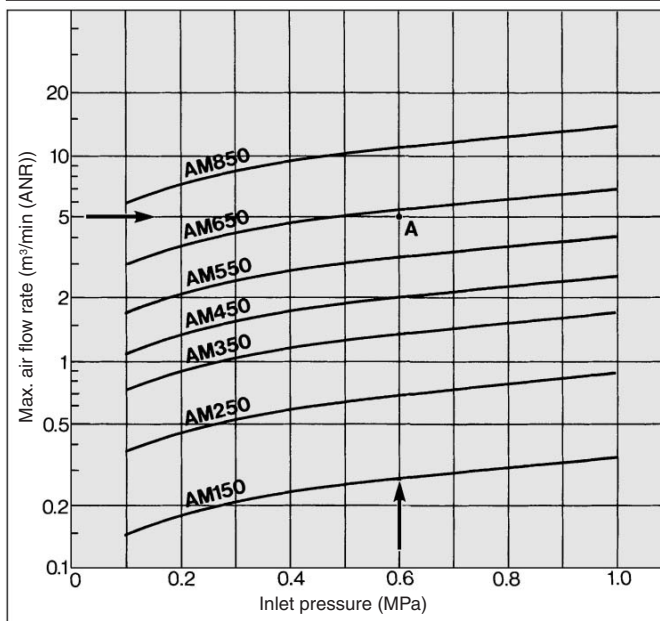

Model Selection

Select the model in accordance with the following procedure taking the inlet pressure and max. air flow into consideration.

(Example) Inlet pressure: 0.6 MPa

Max. air flow capacity: 5 m³/min (ANR)

1. Select the point of contact A of inlet pressure and max. air capacity in the graph.
2. AM650 is obtained when the max. flow line is above the point of intersection A in the graph.



Note) Make sure to select a model that has the maximum flow rate line above the obtained intersecting point. With a model that has the maximum flow rate line below the obtained intersecting point, the flow rate will be exceeded, thus leading to a problem such as being unable to satisfy the specifications.

AM150 to AM650 Dimensions

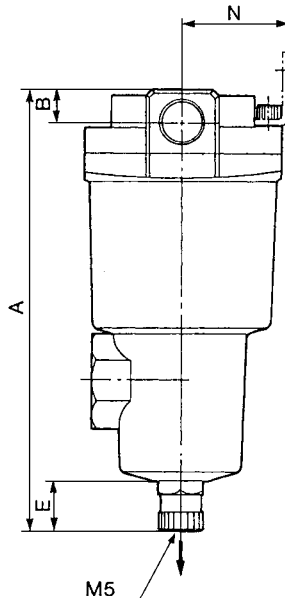
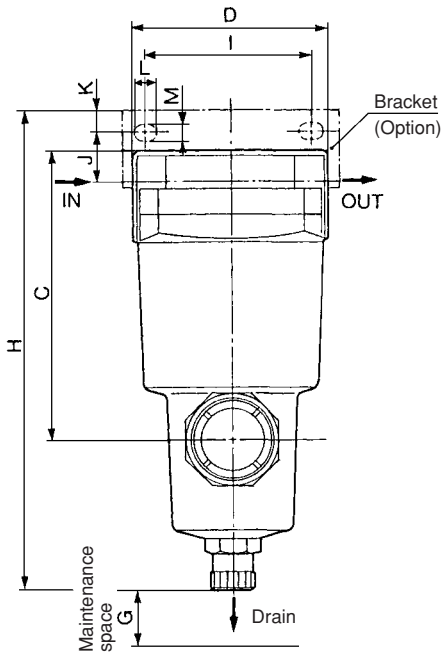
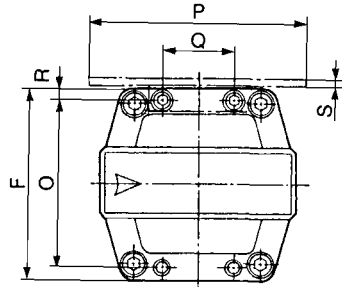

Accessory

D: With auto-drain (N.O.)

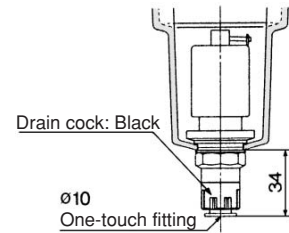

C: With auto-drain (N.C.)

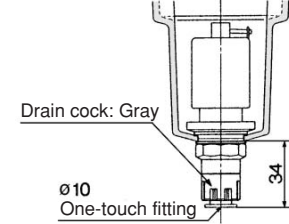

* N.C. auto-drain not available for AM650.

Option

J: With drain guide

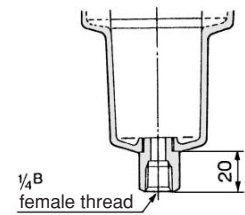

T: With element service indicator

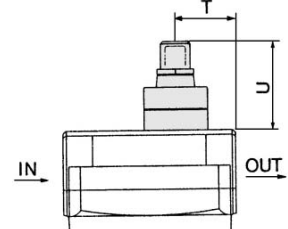

Model	Port size (Nominal size B)	A	B	C	D	E	F	G	Dimensions with mounting bracket											Element service indicator		
									H	I	J	K	L	M	N	O	P	Q	R	S	T	U
AM150	1/8, 1/4, 3/8	159	13	100	63	20	63	10	166	56	15	5	9	5.5	35	54	70	26	4.5	1.6	24	37
	1/4, 3/8	172	13	113	76	20	76	10	187	66	20	8	12	6	40	66	84	28	5	2.0	27	37
AM250	1/2	178	16	119	76	20	76	10	187	66	17	8	12	6	40	66	84	28	5	2.0	27	37
	3/8, 1/2	204	16	145	90	20	90	10	218	80	22	8	14	7	50	80	100	34	5	2.3	32	37
AM350	3/4	210	19	151	90	20	90	10	218	80	19	8	14	7	50	80	100	34	5	2.3	32	37
	1/2, 3/4	225	19	166	106	20	106	10	241	90	25	10	14	9	55	88	110	50	9	3.2	37	37
AM450	1	232	22	173	106	20	106	10	241	90	21	10	14	9	55	88	110	50	9	3.2	37	37
	3/4, 1	259	22	200	122	20	122	10	277	100	30	10	16	9	65	102	130	60	10	4.5	39	37
AM650	1, 1 1/2	311	32	253	160	20	160	10	334	150	40	15	20	11	85	136	180	76	12	4.5	55	37

HA

AT

ID

AMG

AFF

AM

Misc.

Series AM

AM850 Dimensions

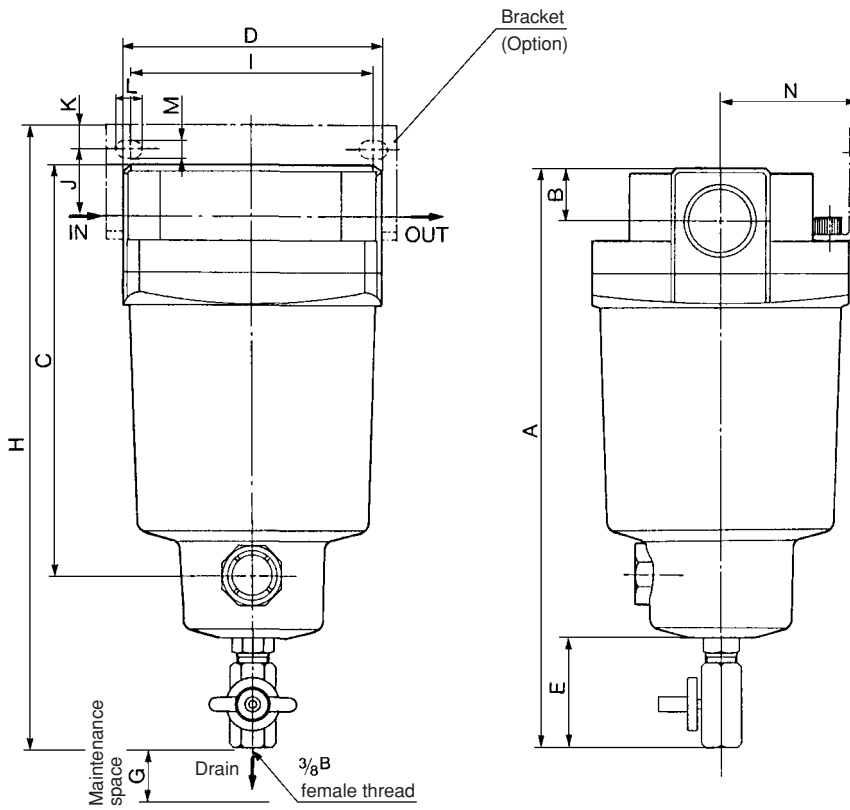
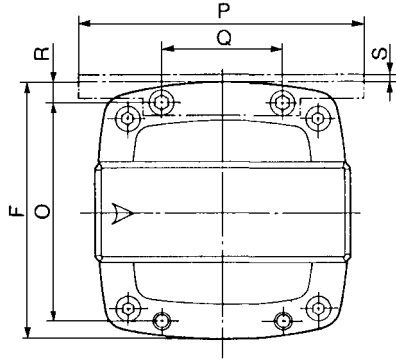

Accessory

D: With auto-drain (N.O.) for AM850

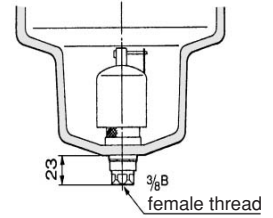

Option

T: With element service indicator

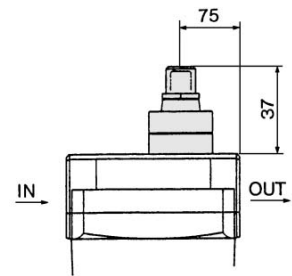



Model	Port size (Nominal size B)	A	B	C	D	E	F	G	Dimensions with mounting bracket											
									H	I	J	K	L	M	N	O	P	Q	R	S
AM850	1 1/2, 2	460.5	42	348	220	57.5	220	10	463.5	180	30	15	24	13	120	184	220	110	18	6.0



Safety Instructions

These safety instructions are intended to prevent a hazardous situation and/or equipment damage. These instructions indicate the level of potential hazard by labels of "Caution", "Warning" or "Danger". To ensure safety, be sure to observe ISO 4414 ^{Note 1)}, JIS B 8370 ^{Note 2)} and other safety practices.

 **Caution** : Operator error could result in injury or equipment damage.

 **Warning** : Operator error could result in serious injury or loss of life.

 **Danger** : In extreme conditions, there is a possible result of serious injury or loss of life.

Note 1) ISO 4414: Pneumatic fluid power--General rules relating to systems.

Note 2) JIS B 8370: General Rules for Pneumatic Equipment

Warning

1. The compatibility of pneumatic equipment is the responsibility of the person who designs the pneumatic system or decides its specifications.

Since the products specified here are used in various operating conditions, their compatibility for the specific pneumatic system must be based on specifications or after analysis and/or tests to meet your specific requirements. The expected performance and safety assurance will be the responsibility of the person who has determined the compatibility of the system. This person should continuously review the suitability of all items specified, referring to the latest catalog information with a view to giving due consideration to any possibility of equipment failure when configuring a system.

2. Only trained personnel should operate pneumatically operated machinery and equipment.

Compressed air can be dangerous if an operator is unfamiliar with it. Assembly, handling or repair of pneumatic systems should be performed by trained and experienced operators.

3. Do not service machinery/equipment or attempt to remove components until safety is confirmed.

1. Inspection and maintenance of machinery/equipment should only be performed once measures to prevent falling or runaway of the driver objects have been confirmed.
2. When equipment is to be removed, confirm the safety process as mentioned above. Cut the supply pressure for this equipment and exhaust all residual compressed air in the system.
3. Before machinery/equipment is restarted, take measures to prevent shooting-out of cylinder piston rod, etc.

4. Contact SMC if the product is to be used in any of the following conditions:

1. Conditions and environments beyond the given specifications, or if product is used outdoors.
2. Installation on equipment in conjunction with atomic energy, railway, air navigation, vehicles, medical equipment, food and beverages, recreation equipment, emergency stop circuits, clutch and brake circuits in press applications, or safety equipment.
3. An application which has the possibility of having negative effects on people, property, or animals, requiring special safety analysis.



Common Precautions

Be sure to read before handling.

For detailed precautions on every series, refer to main text.

Selection

Warning

1. Confirm the specifications.

Products represented in this catalog are designed for use in compressed air applications only (including vacuum), unless otherwise indicated.

Do not use the product outside their design parameters.

Please contact SMC when using the products in applications other than compressed air (including vacuum).

Mounting

Warning

1. Instruction manual

Install the products and operate them only after reading the instruction manual carefully and understanding its contents. Also keep the manual where it can be referred to as necessary.

2. Securing the space for maintenance

When installing the products, please allow access for maintenance.

3. Tightening torque

When installing the products, please follow the listed torque specifications.

Piping

Caution

1. Before piping

Make sure that all debris, cutting oil, dust, etc., are removed from the piping.

2. Wrapping of pipe tape

When screwing piping or fittings into ports, ensure that chips from the pipe threads or sealing material do not get inside the piping. Also, when the pipe tape is used, leave 1.5 to 2 thread ridges exposed at the end of the threads.

Air Supply

Warning

1. Operating fluid

Please consult with SMC when using the product in applications other than compressed air (including vacuum).

Regarding products for general fluid, please ask SMC about applicable fluids.

2. Install an air dryer, aftercooler, etc.

Excessive condensate in a compressed air system may cause valves and other pneumatic equipment to malfunction.

Installation of an air dryer, after cooler etc. is recommended.

3. Drain flushing

If condensate in the drain bowl is not emptied on a regular basis, the bowl will over flow and allow the condensate to enter the compressed air lines.

If the drain bowl is difficult to check and remove, it is recommended that a drain bowl with the auto-drain option be installed.

For compressed air quality, refer to "Air Preparation Equipment" catalog.

4. Use clean air

If the compressed air supply is contaminated with chemicals, synthetic materials, corrosive gas, etc., it may lead to break down or malfunction.

Operating Environment

Warning

1. Do not use in environments where the product is directly exposed to corrosive gases, chemicals, salt water, water or steam.

2. Do not expose the product to direct sunlight for an extended period of time.

3. Do not use in a place subject to heavy vibrations and/or shocks.

4. Do not mount the product in locations where it is exposed to radiant heat.

Maintenance

Warning

1. Maintenance procedures are outlined in the operation manual.

Not following proper procedures could cause the product to malfunction and could lead to damage to the equipment or machine.

2. Maintenance work

If handled improperly, compressed air can be dangerous.

Assembly, handling and repair of pneumatic systems should be performed by qualified personnel only.

3. Drain flushing

Remove drainage from air filters regularly. (Refer to the specifications.)

4. Shut-down before maintenance

Before attempting any kind of maintenance make sure the supply pressure is shut of and all residual air pressure is released from the system to be worked on.

5. Start-up after maintenance and inspection

Apply operating pressure and power to the equipment and check for proper operation and possible air leaks. If operation is abnormal, please verify product set-up parameters.

6. Do not make any modifications to be product.

Do not take the product apart.

Quality Assurance Information (ISO 9001, ISO 14001)

Reliable quality of products in the global market

To enable our customers throughout the world to use our products with even greater confidence, SMC has obtained certification for international standards “ISO 9001” and “ISO 14001”, and created a complete structure for quality assurance and environmental controls. SMC products pursue to meet its customers’ expectations while also considering company’s contribution in society.

Quality management system ISO 9001

This is an international standard for quality control and quality assurance. SMC has obtained a large number of certifications in Japan and overseas, providing assurance to our customers throughout the world.



Environmental management system ISO 14001

This is an international standard related to environmental management systems and environmental inspections. While promoting environmentally friendly automation technology, SMC is also making diligent efforts to preserve the environment.



SMC’s quality control system



Quality policies

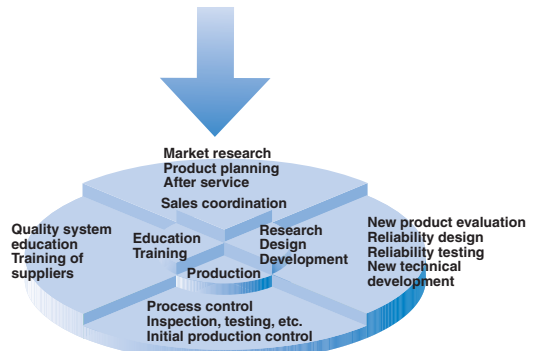

Quality control activities

SMC Product Conforming to Inter

SMC products complying with EN/ISO, CSA/UL standards are supporting



The CE mark indicates that machines and components meet essential requirements of all the EC Directives applied.

It has been obligatory to apply CE marks indicating conformity with EC Directives when machines and components are exported to the member Nations of the EU.

Once "A manufacturer himself" declares a product to be safe by means of CE marking (declaration of conformity by manufacturer), free distribution inside the member Nations of the EU is permissible.

■ CE Mark

SMC provides CE marking to products to which EMC and Low Voltage Directives have been applied, in accordance with CETOP (European hydraulics and pneumatics committee) guide lines.

■ As of February 1998, the following 18 countries will be obliged to conform to CE mark legislation

Iceland, Ireland, United Kingdom, Italy, Austria, Netherlands, Greece, Liechtenstein, Sweden, Spain, Denmark, Germany, Norway, Finland, France, Belgium, Portugal, Luxembourg

■ EC Directives and Pneumatic Components

• Machinery Directive

The Machinery Directive contains essential health and safety requirements for machinery, as applied to industrial machines e.g. machine tools, injection molding machines and automatic machines. Pneumatic equipment is not specified in Machinery Directive. However, the use of SMC products that are certified as conforming to EN Standards, allows customers to simplify preparation work of the Technical Construction File required for a Declaration of Conformity.

• Electromagnetic Compatibility (EMC) Directive

The EMC Directive specifies electromagnetic compatibility. Equipment which may generate electromagnetic interference or whose function may be compromised by electromagnetic interference is required to be immune to electromagnetic affects (EMS/immunity) without emitting excessive electromagnetic affects (EMI/emission).

• Low Voltage Directive

This directive is applied to products, which operate above 50 VAC to 1000 VAC and 75 VDC to 1500 VDC operating voltage, and require electrical safety measures to be introduced.

• Simple Pressure Vessels Directive

This directive is applied to welded vessels whose maximum operating pressure (PS) and volume of vessel (V) exceed 50 bar/L. Such vessels require EC type examination and then CE marking.

national Standards

you to comply with EC directives and CSA/UL standards.



■ CSA Standards & UL Standards

UL and CSA standards have been applied in North America (U.S.A. and Canada) symbolizing safety of electric products, and are defined to mainly prevent danger from electric shock or fire, resulting from trouble with electric products. Both UL and CSA standards are acknowledged in North America as the first class certifying body. They have a long experience and ability for issuing product safety certificate. Products approved by CSA or UL standards are accepted in most states and governments beyond question.

Since CSA is a test certifying body as the National Recognized Testing Laboratory (NRTL) within the jurisdiction of Occupational Safety and Health Administration (OSHA), SMC was tested for compliance with CSA Standards and UL Standards at the same time and was approved for compliance with the two Standards. The above CSA NRTL/C logo is described on a product label in order to indicate that the product is approved by CSA and UL Standards.

■ TSSA (MCCR) Registration Products

TSSA is the regulation in Ontario State, Canada. The products that the operating pressure is more than 5 psi (0.03 MPa) and the piping size is bigger than 1 inch. fall into the scope of TSSA regulation.

Products conforming to CE Standard



With CE symbol for simple visual recognition

In this catalog each accredited product series is indicated with a CE mark symbol. However, in some cases, every available models may not meet CE compliance. Please visit our web site for the latest selection of available models with CE mark.

<http://www.smcworld.com>

SMC's Global Service Network

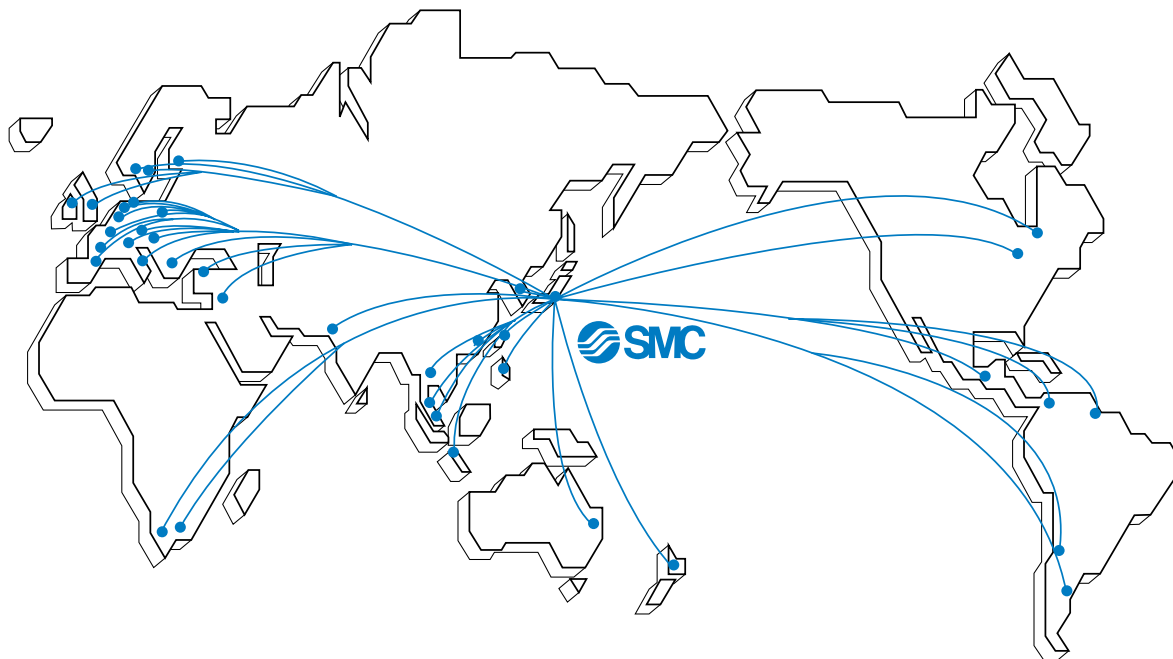

America

U.S.A. **SMC Corporation of America**

3011 North Franklin Road Indianapolis, IN 46226, U.S.A.
TEL: 317-899-4440 FAX: 317-899-3102

CANADA **SMC Pneumatics (Canada) Ltd.**

6768 Financial Drive Mississauga, Ontario, L5N 7J6 Canada
TEL: 905-812-0400 FAX: 905-812-8686

MEXICO **SMC Corporation (Mexico), S.A. DE C.V.**

Carr. Silao-Trejo K.M. 2.5 S/N, Predio San Jose del Duranzo
C.P. 36100, Silao, Gto., Mexico
TEL: 472-72-2-55-00 FAX: 472-72-2-59-44/2-59-46

CHILE **SMC Pneumatics (Chile) S.A.**

Av. La Montaña 1,115 km. 16.5 P. Norte Parque
Industrial Valle Grande, Lampa Santiago, Chile
TEL: 02-270-8600 FAX: 02-270-8601

ARGENTINA **SMC Argentina S.A.**

Teodoro Garcia 3860 (1427) Buenos Aires, Argentina
TEL: 011-4555-5762 FAX: 011-4555-5762

BOLIVIA **SMC Pneumatics Bolivia S.R.L.**

Avenida Beni Numero 4665
Santa Cruz de la Sierra-Casilla de Correo 2281, Bolivia
TEL: 591-3-3428383 FAX: 591-3-3449900

VENEZUELA **SMC Neumatica Venezuela S.A.**

Apartado 40152, Avenida Nueva Granada, Edificio Wanlac,
Local 5, Caracas 1040-A, Venezuela
TEL: 2-632-1310 FAX: 2-632-3871

PERU (Distributor) **IMPECO Automatizacion Industrial S.A.**

AV. Canevaro 752, Lince, Lima, Peru
TEL: 1-471-6002 FAX: 1-471-0935

URUGUAY (Distributor) **BAKO S.A.**

Galicia 1650 esq. Gaboto C.P. 11200, Montevideo, Uruguay
TEL: 2-401-6603 FAX: 2-409-4306

BRAZIL **SMC Pneumaticos Do Brasil Ltda.**

Rua. Dra. Maria Fidelis, nr. 130, Jardim Piraporinha-Diadema-S.P.
CEP: 09950-350, Brasil
TEL: 11-4051-1177 FAX: 11-4071-6636

COLOMBIA (Distributor) **Airmatic Ltda.**

Calle 18 69-05 Apart. Aereo 081045 Santa Fe de Bogotá, Colombia
TEL: 1-424-9240 FAX: 1-424-9260

Europe

U.K. **SMC Pneumatics (U.K.) Ltd.**

Vincent Avenue, Crownhill, Milton Keynes, MK8 0AN, Buckinghamshire, U.K.
TEL: 01908-563888 FAX: 01908-561185

GERMANY **SMC Pneumatik GmbH**

Boschring 13-15 D-63329 Egelsbach, Germany
TEL: 06103-4020 FAX: 06103-402139

ITALY **SMC Italia S.p.A.**

Via Garibaldi 62 I-20061 Carugate Milano, Italy
TEL: 02-9271365 FAX: 02-9271365

FRANCE **SMC Pneumatique S.A.**

1 Boulevard de Strasbourg, Parc Gustave Eiffel, Bussy Saint Georges, F-77600
Marne La Vallee Cedex 3 France
TEL: 01-64-76-10-00 FAX: 01-64-76-10-10

SWEDEN **SMC Pneumatics Sweden AB**

Ekhagsvägen 29-31, S-141 05 Huddinge, Sweden
TEL: 08-603-07-00 FAX: 08-603-07-10

SWITZERLAND **SMC Pneumatik AG**

Dorfstrasse 7, Postfach 117, CH-8484 Weisslingen, Switzerland
TEL: 052-396-3131 FAX: 052-396-3191

AUSTRIA **SMC Pneumatik GmbH (Austria)**

Girakstrasse 8, A-2100 Korneuburg, Austria
TEL: 0-2262-6228-0 FAX: 0-2262-62285

SPAIN **SMC España, S.A.**

Zuazobidea 14 Pol. Ind. Júndiz 01015 Vitoria, Spain
TEL: 945-184-100 FAX: 945-184-510

IRELAND **SMC Pneumatics (Ireland) Ltd.**

2002 Citywest Business Campus, Naas Road, Saggart, Co. Dublin, Ireland
TEL: 01-403-9000 FAX: 01-466-0385

NETHERLANDS (Associated company) **SMC Pneumatics BV**

De Ruyterkade 120, NL-1011 AB Amsterdam, Netherlands
TEL: 020-5318888 FAX: 020-5318880

GREECE (Distributor) **S.Parianopoulos S.A.**

7, Konstantinoupoleos Street 11855 Athens, Greece
TEL: 01-3426076 FAX: 01-3455578

DENMARK **SMC Pneumatik A/S**

Knudsminde 4 B DK-8300
Odder, Denmark
TEL: 70252900 FAX: 70252901

Europe

FINLAND SMC Pneumatics Finland OY

PL72, Tiistiniityntie 4, SF-02231 ESP00, Finland
TEL: 09-8595-80 FAX: 09-8595-8595

NORWAY SMC Pneumatics Norway A/S

Vollsvæien 13C, Granfoss Næringspark N-1366 LYSAKER, Norway
TEL: 67-12-90-20 FAX: 67-12-90-21

BELGIUM (Distributor) SMC Pneumatics N.V./S.A.

Nijverheidsstraat 20 B-2160 Wommelgem Belgium
TEL: 03-355-1464 FAX: 03-355-1466

POLAND SMC Industrial Automation Polska Sp.z.o.o.

ul. Konstruktorska 11A, PL-02-673 Warszawa, Poland
TEL: 022-548-5085 FAX: 022-548-5087

TURKEY (Distributor) Entek Pnömatik San.ve Tic. Ltd. Sti

Perpa Tic. Merkezi Kat:11 No.1625 80270 Okmeydani Istanbul, Türkiye
TEL: 0212-221-1512 FAX: 0212-221-1519

RUSSIA SMC Pneumatik LLC.

36/40 Sredny prospect V.O. St. Petersburg 199004, Russia
TEL: 812-118-5445 FAX: 812-118-5449

CZECH SMC Industrial Automation CZ s.r.o.

Hudcova 78a, CZ-61200 Brno, Czech Republic
TEL: 05-4121-8034 FAX: 05-4121-8034

HUNGARY SMC Hungary Ipari Automatizálási kft.

Budafoki ut 107-113 1117 Budapest
TEL: 01-371-1343 FAX: 01-371-1344

ROMANIA SMC Romania S.r.l.

Str. Frunzei, Nr. 29, Sector 2, Bucharest, Romania
TEL: 01-3205111 FAX: 01-3261489

SLOVAKIA SMC Priemyselná automatizácia, s.r.o.

Nova 3, SK-83103 Bratislava
TEL: 02-4445-6725 FAX: 02-4445-6028

SLOVENIA SMC Industrijska Avtomatila d.o.o.

Grajski trg 15, SLO- 8360 Zuzemberk, Slovenia
TEL: 07388-5240 FAX: 07388-5249

LATVIA SMC Pneumatics Latvia SIA

Šmerļa ielā 1-705, Rīga LV-1006
TEL: 777 94 74 FAX: 777 94 75

SOUTH AFRICA (Distributor) Hyflo Southern Africa (Pty.) Ltd.

P.O.Box 240 Paardeneiland 7420 South Africa
TEL: 021-511-7021 FAX: 021-511-4456

EGYPT (Distributor) Saadani Trading & Ind. Services

15 Sebaai Street, Miami 21411 Alexandria, Egypt
TEL: 3-548-50-34 FAX: 3-548-50-34

Oceania/Asia

AUSTRALIA SMC Pneumatics (Australia) Pty.Ltd.

14-18 Hudson Avenue Castle Hill NSW 2154, Australia
TEL: 02-9354-8222 FAX: 02-9894-5719

NEW ZEALAND SMC Pneumatics (New Zealand) Ltd.

8C Sylvia Park Road Mt.Wellington Auckland, New Zealand
TEL: 09-573-7007 FAX: 09-573-7002

TAIWAN SMC Pneumatics (Taiwan) Co.,Ltd.

17, Lane 205, Nansan Rd., Sec.2, Luzhu-Hsiang, Taoyuan-Hsien, TAIWAN
TEL: 03-322-3443 FAX: 03-322-3387

HONG KONG SMC Pneumatics (Hong Kong) Ltd.

29/F, Clifford Centre, 778-784 Cheung, Sha Wan Road, Lai Chi Kok, Kowloon, Hong Kong
TEL: 2744-0121 FAX: 2785-1314

SINGAPORE SMC Pneumatics (S.E.A.) Pte. Ltd.

89 Tuas Avenue 1, Jurong Singapore 639520
TEL: 6861-0888 FAX: 6861-1889

PHILIPPINES SHOKETSU SMC Corporation

Unit 201 Common Goal Tower, Madrigal Business Park, Ayala Alabang Muntinlupa, Philippines
TEL: 02-8090565 FAX: 02-8090586

MALAYSIA SMC Pneumatics (S.E.A.) Sdn. Bhd.

Lot 36 Jalan Delima1/1, Subang Hi-Tech Industrial Park, Batu 3 40000 Shah Alam Selangor, Malaysia
TEL: 03-56350590 FAX: 03-56350602

SOUTH KOREA SMC Pneumatics Korea Co., Ltd.

Woolim e-BIZ Center (Room 1008), 170-5, Guro-Dong, Guro-Gu, Seoul, 152-050, South Korea
TEL: 02-3219-0700 FAX: 02-3219-0702

CHINA SMC (China) Co., Ltd.

7 Wan Yuan St. Beijing Economic & Technological Development Zone 100176, China
TEL: 010-67882111 FAX: 010-67881837

THAILAND SMC Thailand Ltd.

134/6 Moo 5, Tiwanon Road, Bangkadi, Amphur Muang, Patumthani 12000, Thailand
TEL: 02-963-7099 FAX: 02-501-2937

INDIA SMC Pneumatics (India) Pvt. Ltd.

D-107 to 112, Phase-2, Extension, Noida, Dist. Gautaim Budh Nagar, U.P. 201 305, India
TEL: (0120)-4568730 FAX: 0120-4568933

INDONESIA (Distributor) P.T. Riyadi Putera Makmur

Jalan Hayam Wuruk Komplek Glodok Jaya No. 27-28 Jakarta 11180 Indonesia
TEL: 021-625 5548 FAX: 021-625 5888

PAKISTAN (Distributor) Jubilee Corporation

First Floor Mercantile Centre, Newton Road Near Boulton Market P.O. Box 6165 Karachi 74000 Pakistan
TEL: 021-243-9070/8449 FAX: 021-241-4589

ISRAEL (Distributor) Baccara Automation Control

Kvutza Geva 18915 Israel
TEL: 04-653-5960 FAX: 04-653-1445

SAUDI ARABIA (Distributor) Assaggaff Trading Est.

P.O. Box 3385 Al-Amir Majed Street, Jeddah-21471, Saudi Arabia
TEL: 02-6761574 FAX: 02-6708173

MIST SEPARATOR SERIES (N)AM

- ✓ Port Sizes 1/4, 3/8, 1/2, 3/4, 1 1/2, 2"
- ✓ Removes 99.9% of Oil Mist and Fine Particles down to 0.3µm
- ✓ Manual or Automatic Drain
- ✓ Cartridge Type Element for easy replacement
- 🔧 Small additional clearance required for cartridge replacement

Mist Separators are also available for the Modular Range of Air Preparation Products



DIMENSIONS

MIST SEPARATOR SERIES NAM

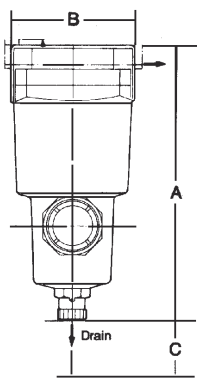

(Clearance required for cartridge change)

Model	Port NPT	A mm	B mm	C mm
NAM150-N02D	1/4	159	63	10
NAM250-N03D	3/8	172	76	10
NAM350-N04D	1/2	204	90	10
NAM450-N06D	3/4	225	106	10
NAM550-N10D	1"	259	122	10
NAM650-N14D	1 1/2"	361	160	10
NAM850-N14D	2"	473	220	10

Manual and Autodrain types are same overall dimensions.

TECHNICAL SPECIFICATIONS

Max Operating Pressure	1MPa / 145PSI
Min Operating Pressure	0.05MPa / 8PSI
Ambient & Fluid Temp	5~60°C / 40~140°F
Filtration Degree	0.3µm
Oil Mist Removal	99.9%
Max Flow Rate l/n/min*	NAM150 300
	NAM250 750
	NAM350 1500
	NAM450 2,200
	NAM550 3,500
	NAM650 6,000
NAM850 12,000	

*0.7MPa Supply, 0.03MPa or less pressure drop

SYMBOLS

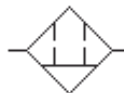

ACCESSORIES

Bracket

NAM150	BM51
NAM250	BM52
NAM350	BM53
NAM450	BM54
NAM550	BM55
NAM650	BM56
NAM850	BM57

Filter element

NAM150	AM-EL150
NAM250	AM-EL250
NAM350	AM-EL350
NAM450	AM-EL450
NAM550	AM-EL550
NAM650	AM-EL650
NAM850	AM-EL850
GD40-2-01	Differential pressure gauge

FOR FURTHER TECHNICAL DETAILS ON THIS PRODUCT CONSULT SMC CUSTOMER SERVICE

HOW TO ORDER

MIST SEPARATOR SERIES (N)AM

Note) (N)AM

AM - Japanese

NAM - North American

(N)AM

BODY SIZE

- 150 ... 1/8 Basis
- 250 ... 1/4 Basis
- 350 ... 3/8 Basis
- 450 ... 1/2 Basis
- 550 ... 3/4 Basis
- 650 ... 1 Basis
- 850 ... 1 1/2 Basis

THREAD

-Rc(PT)* Remove (N) when ordering
- FG(PF)* Remove (N) when ordering
- NNPT

PORT SIZE

- 01 ... 1/8
- 02 ... 1/4
- 03 ... 3/8
- 04 ... 1/2
- 06 ... 3/4
- 10 ... 1
- 14 ... 1 1/2
- 20 ... 2

OPTIONS

-None
- BBracket
- CNC Autodrain
- DNO Autodrain

SUB-STANDARD SPECIFICATIONS

- YDrain Guide 1/4 Internal Thread
- MWith Drain Lock M5 Screw
- RIN, OUT Reverse Direction

SEE INSIDE FRONT COVER FOR
DETAILS OF YOUR LOCAL SALES OFFICE



FOR FURTHER TECHNICAL
DETAILS ON THIS
PRODUCT CONSULT
SMC CUSTOMER SERVICE

Mist Separator

Series AM

Can remove oil mist in compressed air and remove particles such as rust or carbon of more than 0.3 μm.

Modular connection is possible with AM150C to 550C.
(For details, refer to page 61.)



AM150C to 550C



AM650/850

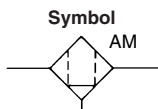

Made to Order
(For details, refer to page 67.)

Model

Model	AM150C	AM250C	AM350C	AM450C	AM550C	AM650	AM850
Rated flow (ℓ/min (ANR)) ^{Note)}	300	750	1500	2200	3700	6000	12000
Port size	1/8, 1/4	1/4, 3/8	3/8, 1/2	1/2, 3/4	3/4, 1	1, 1 1/2	1 1/2, 2
Mass (kg)	0.38	0.55	0.9	1.4	2.1	4.2	10.5



Note) Max. flow at 0.7 MPa.

Max. flow varies depending on the operating pressure.

Refer to "Flow Characteristics" (page 21) and "Maximum Air Flow" (page 22).



Note) Refer to "Made to Order" (page 67) for high flow type of AM850 or more.

Specifications

Fluid	Compressed air
Max. operating pressure	1.0 MPa
Min. operating pressure*	0.05 MPa
Proof pressure	1.5 MPa
Ambient and fluid temperature	5 to 60°C
Nominal filtration rating	0.3 μm (Filtration efficiency: 99.9%)
Oil mist density at outlet	Max. 1.0 mg/m ³ (ANR) (=0.8 ppm)*
Element life	2 years or when pressure drop reached 0.1 MPa

* With auto drain: 0.1 MPa (N.O. type) or 0.15 MPa (N.C. type)

* Oil mist density at 30 mg/m³ (ANR) blown out by compressor.

Accessory

Applicable model	AM150C	AM250C	AM350C	AM450C	AM550C	AM650	AM850
Bracket assembly (with 2 mounting screws)	AM-BM101	AM-BM102	AM-BM103	AM-BM104	AM-BM105	BM56	BM57

⚠ Caution

Be sure to read this before handling.

Refer to back pages 1 and 2 for Safety Instructions, "Precautions for Handling Pneumatic Devices" (M-03-E3A) for Common Precautions, and back pages 3 through to 7 for Specific Product Precautions.

How to Order



AM150C to 550C

AM 550C - [] 10 [] [] - [] - []

Body size

Symbol	Applicable compressor output (guide)
150C	2.2 kW
250C	3.7 kW
350C	7.5 kW
450C	11 kW
550C	22 kW

Thread type

Symbol	Type
Nil	Rc
F	G*1
N	NPT

*1 Conforms to ISO1179-1.

Port size

Symbol	Size	Applicable body size				
		150C	250C	350C	450C	550C
01	1/8	●				
02	1/4	●	●			
03	3/8		●	●		
04	1/2			●	●	
06	3/4				●	●
10	1					●

Accessory

Symbol	Description
Nil	—
B	Bracket *2

*2 Bracket is included, (but not assembled).

Made to Order

("How to Order" and the applicable models are different from those shown on this page. Be sure to refer to "Made to Order".)

Symbol	Description	Page for details
Nil	—	—
X6	With differential pressure gauge (GD40-2-01)	P.68
X15	With IN-OUT flange	P.69
X17	With differential pressure gauge (GD40-2-01) and IN-OUT flange	P.69
X26	N.C., N.O. auto drain, drain piping type	P.70

Option *3

Symbol	Description
Nil	—
F	Rubber material: Fluororubber
H	For medium air pressure (1.6 MPa)
J	Drain guide 1/4 female threaded *4
R	IN-OUT reversal direction
S	With differential pressure switch (125 VAC, 30 VDC) *5, (Note)
U	With differential pressure switch (30 VDC) *5, (Note)
T	Element service indicator
V	Degreasing wash, *6 white vaseline

*4 Drain piping and piping for a stop valve such as ball valve are required.

*5 Differential pressure gauge is included, (but not assembled).

*6 Only body/housing is degreasing washed.

(Note) Order "U" if conformity to the EU directive is required.

Auto Drain Specifications/Option Combinations

○ : Available □ : Not available

○, △ : Plural options cannot be selected.

(i.e. Combinations such as C-FV, D-FHV, D-FHV, J-ST are not possible.)

Symbol	F	H	R	S	U	T	V
Auto drain specifications Nil	○	○	○	○	○	○	○
C	△	□	○	○	○	○	△
D	△	△	○	○	○	○	△
J	○	○	○	○	○	○	○

Auto drain *3

Symbol	Description
Nil	Drain cock (Without auto drain)
C	N.C. auto drain
D	N.O. auto drain

*3 Refer to "Auto Drain Specifications/Option Combinations".

Options

Symbol F: Rubber material: Fluororubber

Fluororubber is used for the parts such as O-ring and gasket.

Symbol H: For medium air pressure (1.6 MPa)

Can be used up to 1.6 MPa at maximum.

Symbol J: Drain guide 1/4 female threaded

Can be piped to the drain exhaust port.

Symbol R: IN-OUT reversal direction

Air flow in the separator is changed to right to left. (Air flow direction of the standard: Left to right.)

Symbol S: With differential pressure switch (with indicator)

Saturation of the separator can be observed visually or by an electrical signal. (Element life check)

Symbol U: With differential pressure switch (with indicator)

Saturation of the separator can be observed visually or by an electrical signal. (Element life check)

Symbol T: With element service indicator

Saturation of the separator can be observed visually. (Element life check)

* The rated contact voltage is different from "U".

Max. contact capacity: 10 VA AC, 10 W DC
Rated contact voltage (max. operating current): 125 V AC (0.08 A), 30 V DC (0.33 A)

* The rated contact voltage is different from "S".

Max. contact capacity: 10 W DC
Rated contact voltage (max. operating current): 30 V DC (0.33 A)

Symbol V: Degreasing wash, white vaseline

Body/housing is degreasing washed. The lubrication grease for O-ring and gasket is changed to white vaseline.

Reed switch

Reed switch



How to Order

AM650/850

AM **650** - [] **10** [] [] - [] - []

Body size

Symbol	Applicable compressor output (guide)
650	37 kW
850	75 kW

Thread type

Symbol	Type
Nil	Rc
F	G
N	NPT

Port size

Symbol	Size	Applicable body size	
		650	850
10	1	●	—
14	1 1/2	●	●
20	2	—	●

Accessory

Symbol	Description
Nil	—
B	Bracket *1

*1 Bracket is included, (but not assembled).

Made to Order

("How to Order" and the applicable models are different from those shown on this page. Be sure to refer to "Made to Order".)

Symbol	Description	Page for details
Nil	—	—
X6	With differential pressure gauge (GD40-2-01)	P.68
X37	With differential pressure switch (With indicator, 125 VAC, 30 VDC)	P.68
X15	With IN-OUT flange	P.69
X17	With differential pressure gauge (GD40-2-01) and IN-OUT flange	P.69
X26	N.C., N.O. auto drain, drain piping type	P.70
X12	White vaseline specifications	P.70

Option *2

Symbol	Description
Nil	—
J	Drain guide 1/4 female threaded *4
R	IN-OUT reversal direction
T	With element service indicator

*4 Drain piping and piping for a stop valve such as ball valve are required.

Auto drain *2

Symbol	Description
Nil	Drain cock (Without auto drain) *3
D	N.O. auto drain

*2 Refer to "Auto Drain Specifications/Option Combinations".

*3 Body size 850 is equipped with a ball valve (Rc3/8 female threaded). Mount a piping adapter IDF-AP609 (page 62) to the ball valve if NPT3/8 female threaded is required.



Note) Refer to "How to Order Bowl Assembly" on page 63.

Auto Drain Specifications/Option Combinations

○ : Available □ : Not available

Auto drain specifications/Option			Auto drain specifications		Option			Applicable model	
			D	J	R	T	AM650	AM850	
Auto drain specifications	N.O. auto drain	D	□	□	○	○	○	○	
	Drain guide 1/4	J	□	□	○	○	○	□	
Option	IN-OUT reversal direction	R	○	○	□	○	○	○	
	With element service indicator	T	○	○	○	□	○	○	

Series AM

Flow Characteristics (Element oil saturation)



Note) Compressed air over max. flow line in the table below may not meet the specifications of the product. It may cause damage to the element.

AM150C

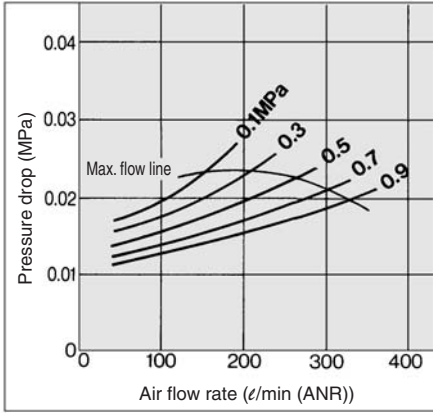

AM450C

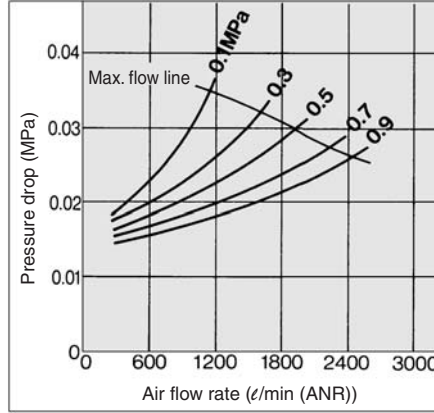

AM850

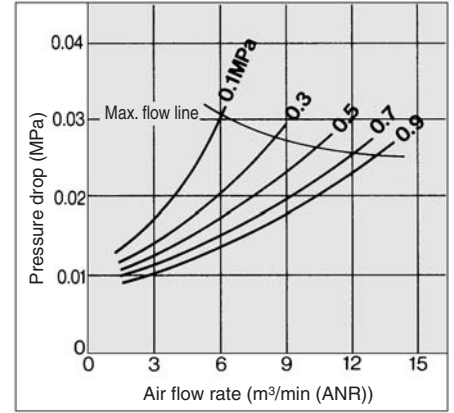

AM250C

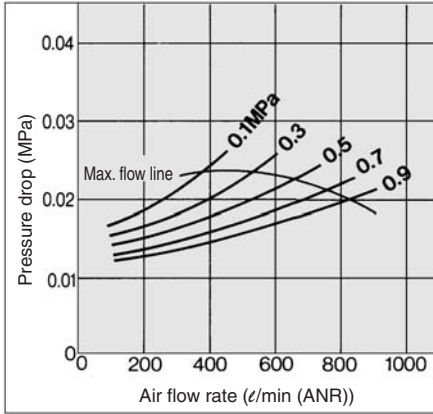

AM550C

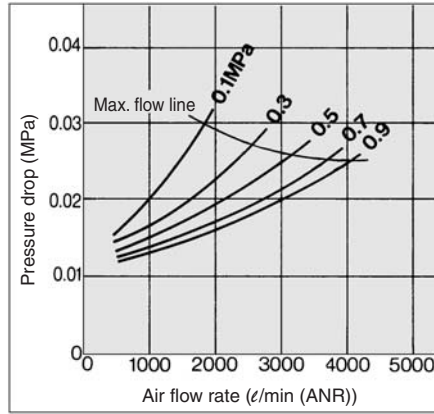

AM350C

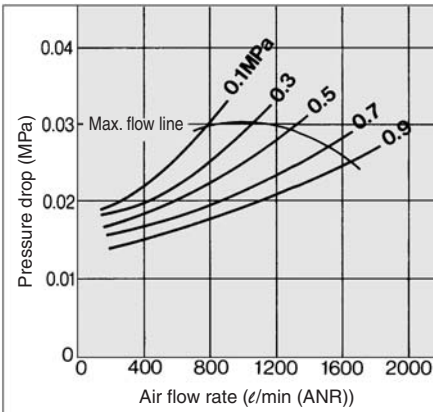

AM650

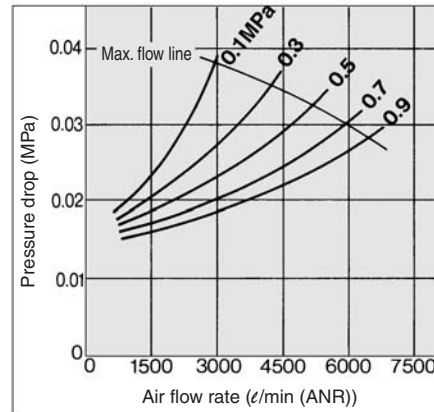

Construction

AM150C to 550C, AM650

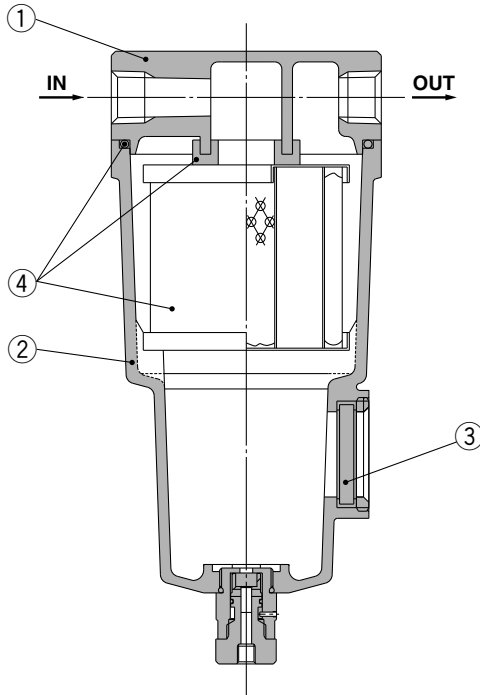

AM850

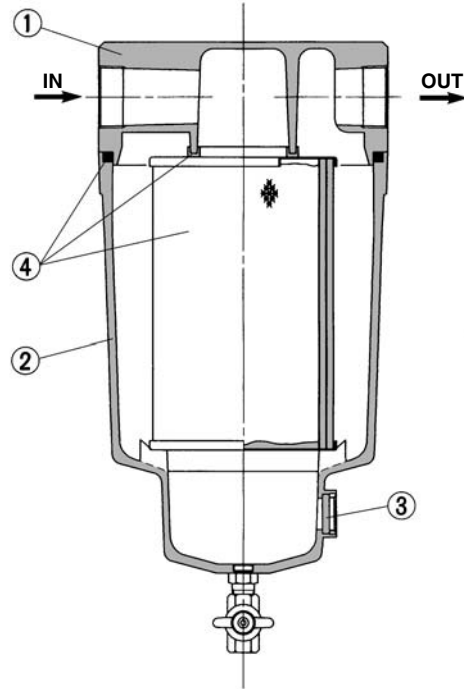

Component Parts

No.	Description	Material	Note
1	Body	Aluminum die-casted	Chrome treated
2	Housing	Aluminum die-casted*	Epoxy coating on inner surface
3	Sight glass	Tempered glass	—

* The AM850 is aluminum casted.



Note) Refer to "How to Order Bowl Assembly" on page 63.



Note) Sight glass is indicated in the figure for easy understanding of component parts. However, it differs from the actual construction. Refer to dimensions on pages 23 through to 25 for details.

Replacement Parts

No.	Description	Material	Applicable model	Model						
				AM150C	AM250C	AM350C	AM450C	AM550C	AM650	AM850
4	Element assembly	Glass fiber, others	Except option F	AM-EL150	AM-EL250	AM-EL350	AM-EL450	AM-EL550	AM-EL650	AM-EL850
			For option F	AM-EL150-F	AM-EL250-F	AM-EL350-F	AM-EL450-F	AM-EL550-F	—	—

* Element assembly: With gasket (1 pc.) and O-ring (1 pc.)

* Refer to back page 6 for replacement of auto drain.

* Element assemblies for Made to Order (X6, X12, X15, X17, X20, X26, X37) are same as those for standard (see the above table).

Maximum Air Flow

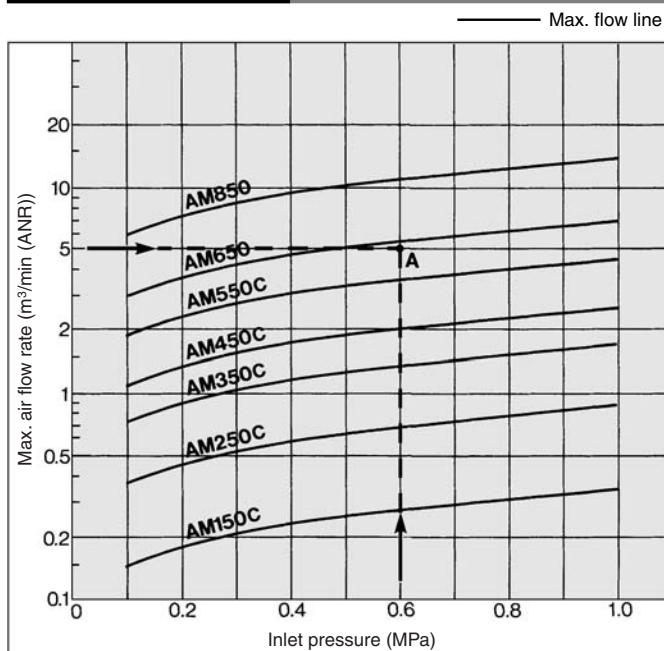

Model Selection

Select a model in accordance with the following procedure taking the inlet pressure and the max. air flow rate into consideration.

(Example) Inlet pressure: 0.6 MPa

Max. air flow rate: 5 m³/min (ANR)

1. Obtain the intersecting point A of inlet pressure and max. air flow rate in the graph.
2. The AM650 is obtained when the max. flow line is above the intersecting point A in the graph.



Note) Make sure to select a model that has the max. flow line above the obtained intersecting point. With a model that has the max. flow line below the obtained intersecting point, the flow rate will be exceeded, thus leading to a problem such as being unable to satisfy the specifications.

Series AM

Dimensions

AM150C to 550C

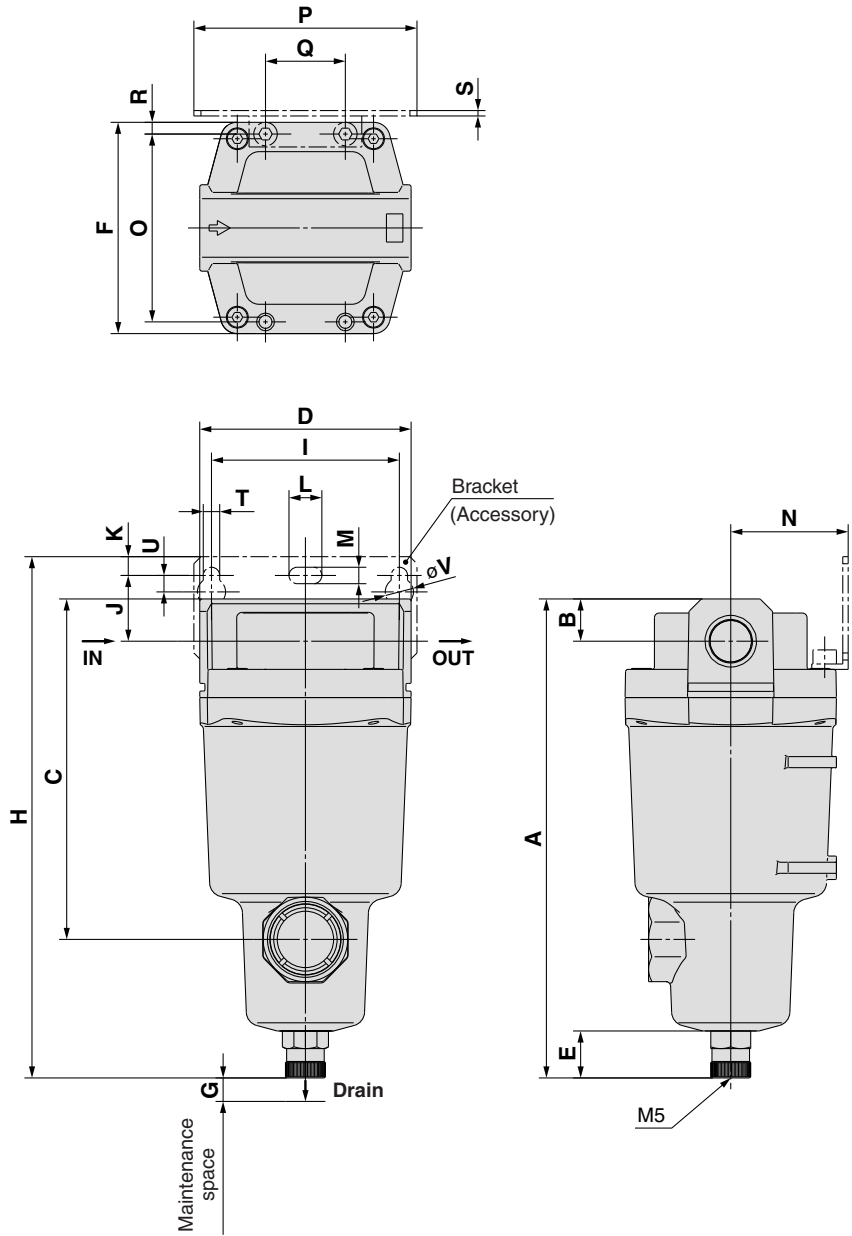

Auto drain

C: With auto drain (N.C.)
D: With auto drain (N.O.)

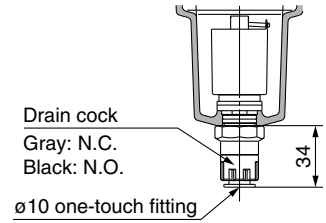

Combination of D: With auto drain (N.O.)
and H: For medium air pressure

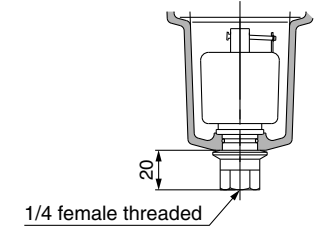

Option

J: Drain guide 1/4 female threaded

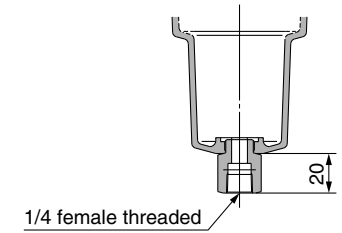

S, U: With differential pressure switch (with indicator)

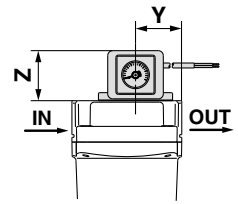

T: With element service indicator

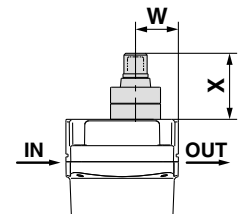

Model	Port size	A	B	C	D	E	F	G	Bracket related dimensions													Element service indicator related dimensions		Differential pressure switch related dimensions			
									H	I	J	K	T	U	L	M	V	N	O	P	Q	R	S	W	X	Y	Z
AM150C	1/8, 1/4	158	10	99	63	20	63	10	173	56	20	5	6	6	12	6	10	35	54	70	26	4.5	1.6	24	37	32	41
AM250C	1/4, 3/8	172	14	113	76	20	76	10	190	66	24	8	6	6	12	6	10	40	66	80	28	5	2	27	37	36	41
AM350C	3/8, 1/2	204	18	145	90	20	90	10	222	80	28	8	7	7	14	7	12	50	80	95	34	5	2.3	32	37	42	41
AM450C	1/2, 3/4	225	20	166	106	20	106	10	246	90	31	10	9	9	18	9	15	55	88	111	50	9	3.2	37	37	43	41
AM550C	3/4, 1	259	24	200	122	20	122	15	278	100	33	10	9	9	18	9	15	65	102	126	60	10	3.2	39	37	51	41

Dimensions

AM650

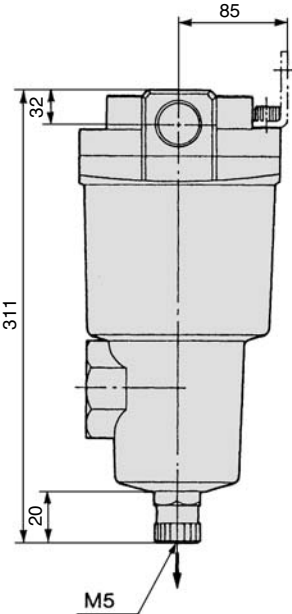
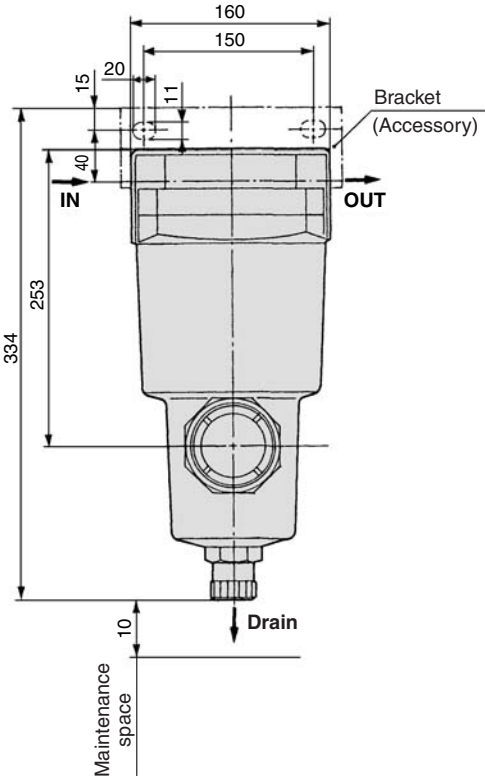
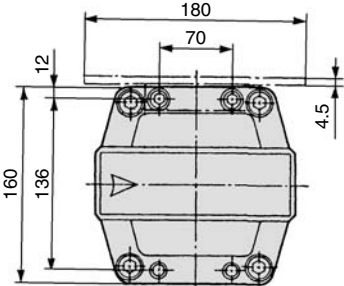

Auto drain

D: With auto drain (N.O.)

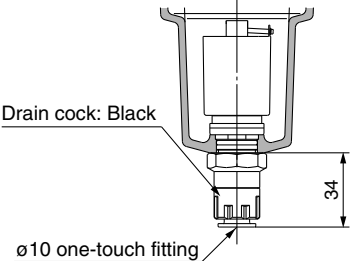

Option

J: Drain guide 1/4 female threaded

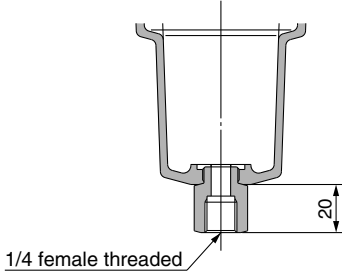

T: With element service indicator

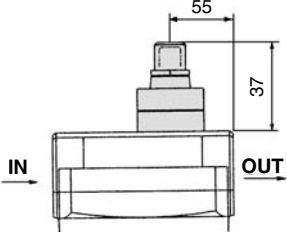

Series AM

Dimensions

AM850

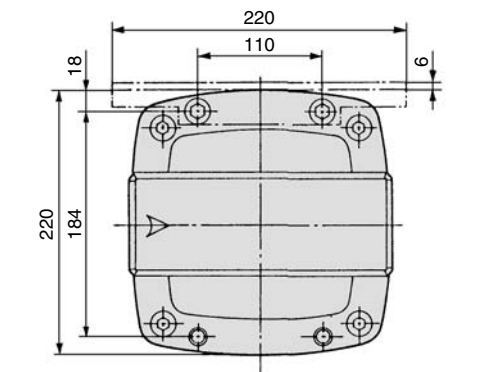

Auto drain

D: With auto drain (N.O.)
for AM850

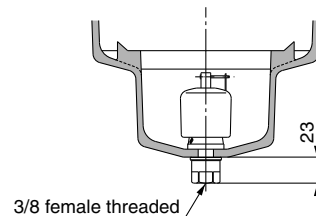

Option

T: With element service indicator

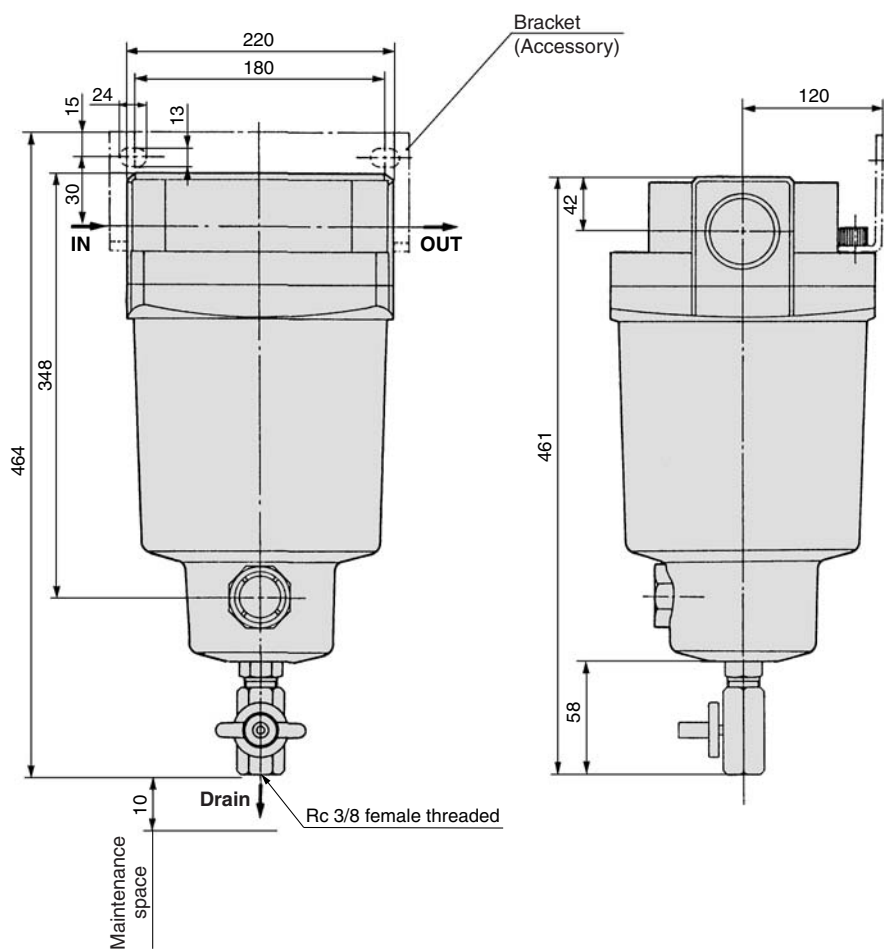
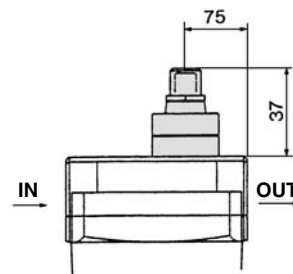

Series AMF

Spacer for Modular Connection

Select a spacer from those listed below when combining modular type AFF2C to 22C, AM□150C to 550C. The spacer must be ordered separately.

(Note: Spacer with bracket (Y200T to Y600T) cannot be used.)



⚠ Caution

- Modular connection
- Mount the attached bracket on one side when connecting 2 sets.
- Mount the attached brackets on both sides when connecting 3 sets or more.
- As a guideline for the number of brackets, one bracket should be mounted for every 2 products.

Combination examples of modular applicable products

Arrangement example

- AMH250C-□□B — 1 pc.
- AME250C — 1 pc.
- Y300 — 1 pc.

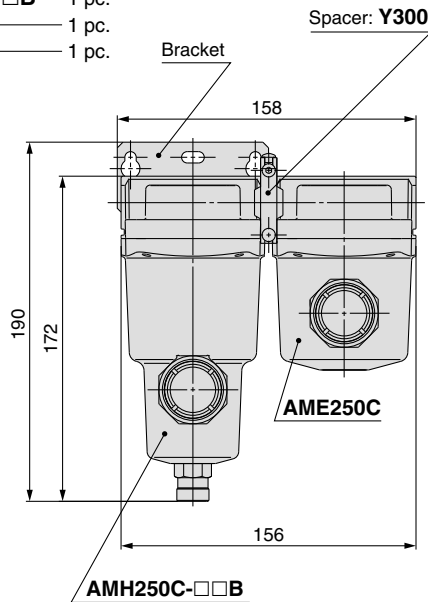

Arrangement example

- AMH250C-□□B — 1 pc.
- AME250C — 1 pc.
- AMF250C-□□B — 1 pc.
- Y300 — 2 pcs.

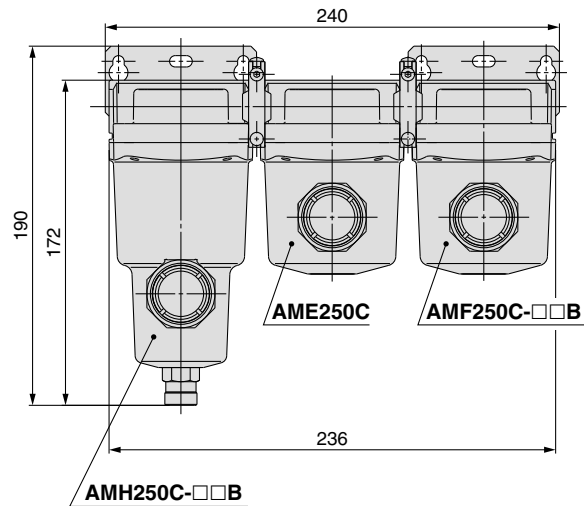

Spacer

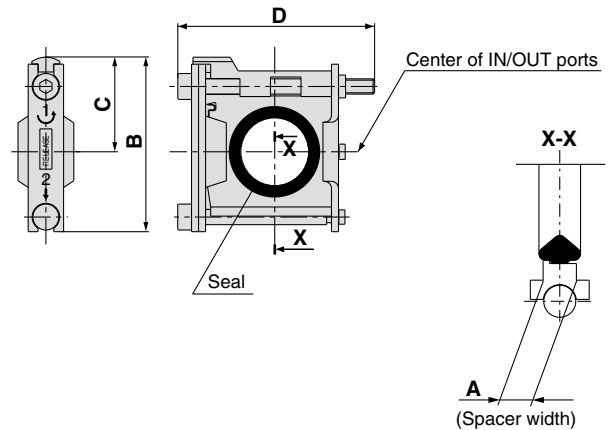
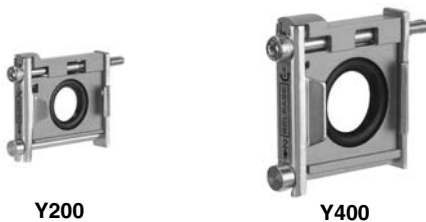

Model	A	B	C	D	Model
Y200	3	35.5	18.5	48	AFF2C, AM□150C
Y300	4	47	26	59	AFF4C, AM□250C
Y400	5	57	31	65	AFF8C, AM□350C
Y500	5	61	33	75	AFF11C, AM□450C
Y600	6	75.5	41	86	AFF22C, AM□550C

Replacement Parts

Description	Material	Part no.				
		Y200	Y300	Y400	Y500	Y600
Seal	HNBR	Y200P-061S	Y300P-060S	Y400P-060S	Y500P-060S	Y600P-060S

Piping Adapter

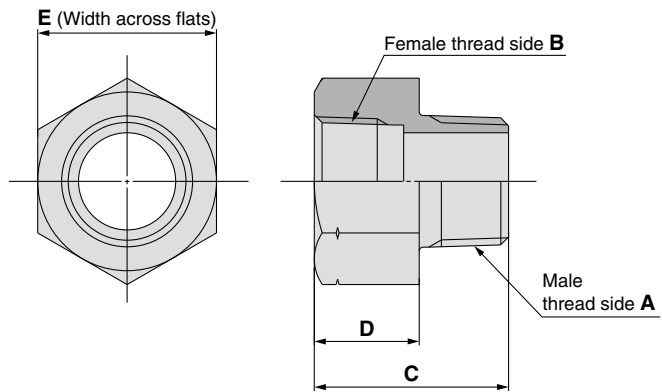

Dimensions

(mm)

Part no.	Thread type and port size		C	D	E	Material
	Male thread side A	Female thread side B				
IDF-AP609	R 3/8	NPT 3/8	30	15	22	Brass

Bowl Assembly

AFF-CA□/AM□-CA□

Bowl Assembly

Bowl assembly for the AFF and AM□ series can be replaced without removing the main body from piping if the drain exhaust specification is to be changed from the drain cock type to the auto drain type or if the bowl has been damaged.

How to Order Bowl Assembly

■ AFF2C to 22C, AM, AMD, AMH, AMG150C to 550C

AM - CA □ - □ - □ - □

Body size

150C
250C
350C
450C
550C

Option

Symbol	Description
Nil	—
F	Rubber material: Fluororubber
H	For medium air pressure (1.6 MPa)
V	Degreasing wash, white vaseline

Drain exhaust

Symbol	Description
A	With drain cock
C	With N.C. auto drain
D	With N.O. auto drain
J	With drain guide ^{Note 1)}

Note 1) Drain piping and piping for a stop valve such as a ball valve are required.

Thread type ^{Note 2)}

Symbol	Type
Nil	Rc
F ^{Note 3)}	G
N	NPT

Note 2) Corresponded to the drain exhaust symbol C, D and J. Select according to the body thread type.

Note 3) Not corresponded to the drain exhaust symbol C and D. Select no symbol when the body thread symbol is F.

Applicable Model

Bowl assembly model	Applicable model
AM-CA150C	AFF2C, AM150C, AMD150C, AMH150C, AMG150C
AM-CA250C	AFF4C, AM250C, AMD250C, AMH250C, AMG250C
AM-CA350C	AFF8C, AM350C, AMD350C, AMH350C, AMG350C
AM-CA450C	AFF11C, AM450C, AMD450C, AMH450C, AMG450C
AM-CA550C	AFF22C, AM550C, AMD550C, AMH550C, AMG550C

Auto Drain Specifications/ Option Combinations

⊙ : Available □ : Not available
△ : Plural options cannot be selected.
(i.e. Combinations such as C-FV, D-FHV are not possible.)

Symbol	F	H	V
A	⊙	⊙	⊙
C	△	□	△
D	△	△	△
J	⊙	⊙	⊙

■ AFF37B/75B

AFF - CA 37B - □ - □

Body size

37B
75B

Thread type ^{Note 3)}

Symbol	Type
Nil	Rc
F ^{Note 4)}	G
N	NPT

Note 3) Corresponded to the drain exhaust symbol D and J. Select according to the body thread type.

Note 4) Not corresponded to the drain exhaust symbol C and D. Select no symbol when the body thread symbol is F.

Drain exhaust

Symbol	Description
A	With drain cock ^{Note 1)}
D	With N.O. auto drain
J	With drain guide ^{Note 2)}

Note 1) Body size 75B is equipped with a ball valve (Rc3/8 female threaded). Mount a piping adapter IDF-AP609 (page 62) to the ball valve if NPT3/8 female threaded is required.

Note 2) Drain piping and piping for a stop valve such as a ball valve are required. For body size 75B, substitute with a ball valve. (symbol: A)

How to Order Bowl Assembly

■ AM, AMD, AMH, AMG Series

AM - CA 650 - □ □
AMD
AMH
AMG

Body size

650
850

Thread type Note 3)

Symbol	Type
Nil	Rc
F	G
N	NPT

Note 3) Corresponded to the drain exhaust symbol D and J. Select according to the body thread type.

Drain exhaust

Symbol	Description
A	With drain cock <small>Note 1)</small>
D	With N.O. auto drain
J	With drain guide <small>Note 2)</small>

Note 1) Body size 850 is equipped with a ball valve (Rc3/8 female threaded). Mount a piping adapter IDF-AP609 (page 62) to the ball valve if NPT3/8 female threaded is required.

Note 2) Drain piping and piping for a stop valve such as a ball valve are required.
 For body size 850, substitute with a ball valve. (symbol: A)

■ AME, AMF150C to 550C

AME - CA □ - **A** - □

Body size

150C
250C
350C
450C
550C

Option Note)

Symbol	Description
Nil	—
F	Rubber material: Fluororubber
H	For medium air pressure (1.6 MPa)
V	Degreasing wash, white vaseline

Note) Combination of FH is not available.

Applicable Model

Bowl assembly model	Applicable model
AME-CA150C	AME150C, AMF150C
AME-CA250C	AME250C, AMF250C
AME-CA350C	AME350C, AMF350C
AME-CA450C	AME450C, AMF450C
AME-CA550C	AME550C, AMF550C

■ AME, AMF650/850

AME - CA 650 - A
AMF

Body size

650
850

AFF-CA□/AM□-CA□

Dimensions: AFF, AM, AMD, AMH, AMG Series

Size: AFF2C to 22C, AFF37B, AM□150C to 550C, AM□650

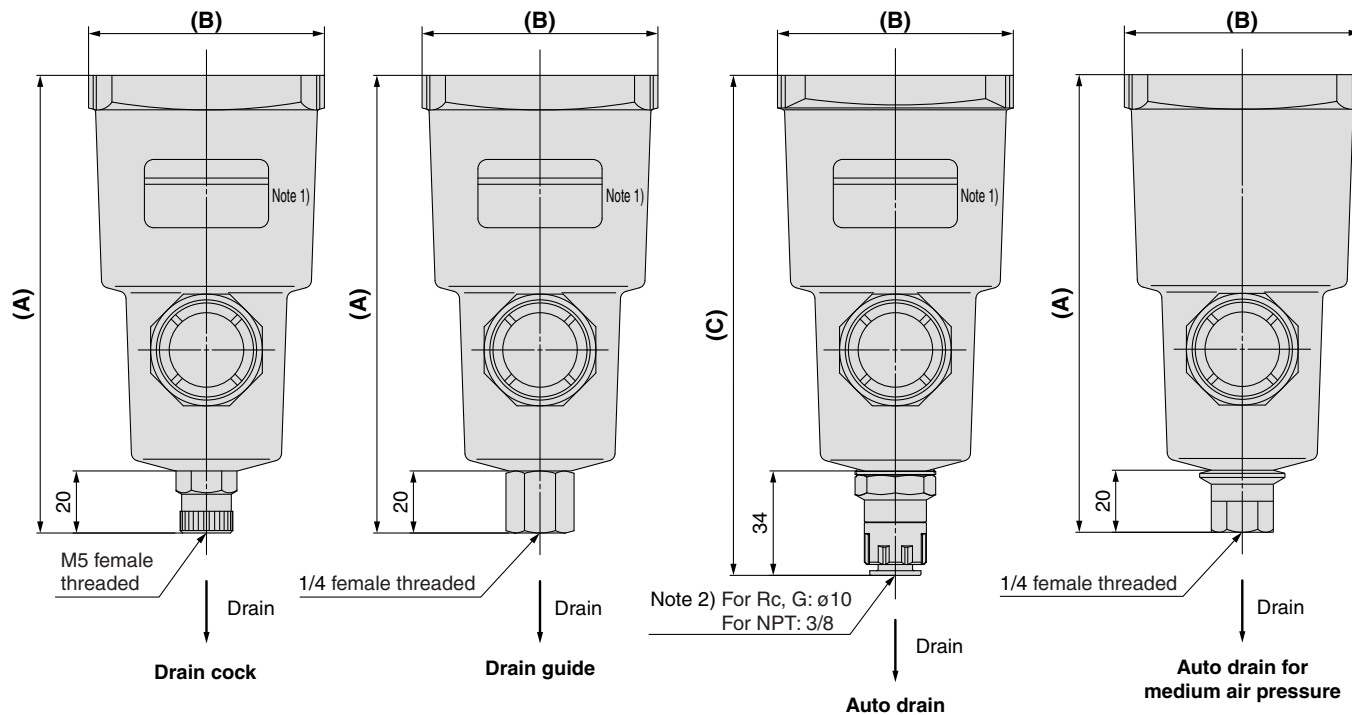

(mm)

AFF series	AM, AMD, AMG, AMH series	A	B	C
Size	Size			
2C	150C	134	63	148
4C	250C	139	76	153
8C	350C	162	90	176
11C	450C	178	106	192
22C	550C	202	122	216
37B	650	245	160	259

Note 1) Model no. labels are not affixed to the AM-CA150C to 550C.

Note 2) Select according to the body thread type.

Applicable tubing size for one-touch fitting

Rc, G: ø10

NPT: ø3/8 inch

Size: AFF75B, AM□850

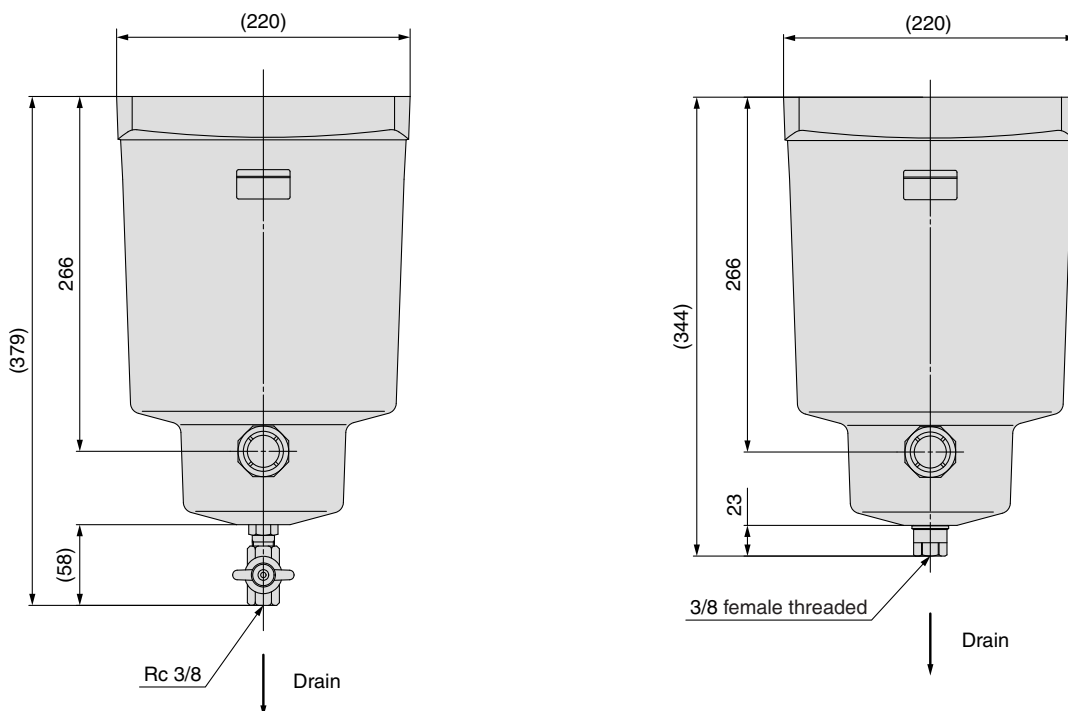

Dimensions: AME, AMF Series

■ AME150C to 550C, AMF150C to 550C

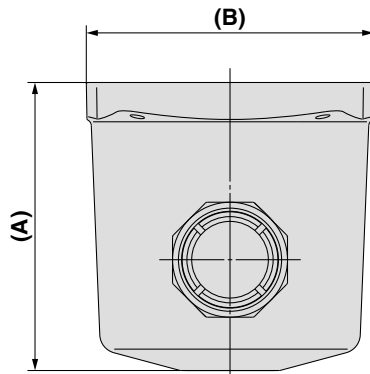

(mm)

AME, AMF series Size	A	B
150	60	63
250	70	76
350	90	90
450	104	106
550	130	122

■ AME650/850, AMF650/850

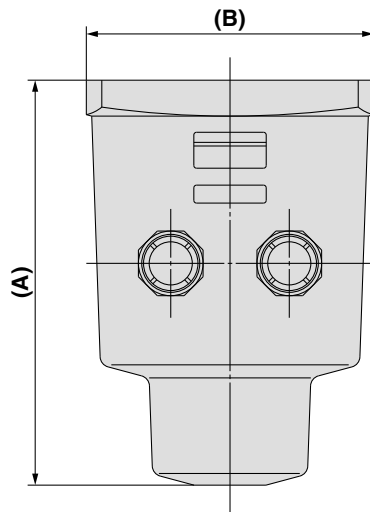

(mm)

AME, AMF series Size	A	B
650	225	160
850	319	120

Compressed Air Cleaning Filter Series

Made to Order/Special Specifications



Please consult with SMC for detailed specifications, size and delivery.

Made to Order

Contents	Symbol	Applicable model							Reference page
		AFF	AM	AMD	AME	AMF	AMG	AMH	
1. With Differential Pressure Gauge (GD40-2-01)	X6	●	●	●	—	—	—	●	P.68
2. With Differential Pressure Switch (With Indicator)	X37	●	●	●	—	—	—	●	
3. With IN-OUT Flange	X15	●	●	●	—	—	●	●	P.69
4. With Pressure Differential Gauge (GD40-2-01), IN-OUT Flange	X17	●	●	●	—	—	—	●	
5. N.C., N.O. Auto Drain, Drain Piping Type	X26	●	●	●	—	—	●	●	P.70
6. White Vaseline Specifications	X12	●	●	●	●	●	●	●	
7. Mist Separator for High Flow Rate (0.3 μm)	X13	●	—	—	—	—	—	—	P.71

Special Specifications

Contents	Applicable model							Reference page
	AFF	AM	AMD	AME	AMF	AMG	AMH	
Clean Series (10-Series)	●	●	●	●	●	—	●	P.72
Copper-free, Fluorine-free (20-Series)	●	●	—	—	—	●	—	

Compressed Air Cleaning Filter Series

Made to Order 1



Please consult with SMC for detailed specifications, size and delivery.

1. With Differential Pressure Gauge (GD40-2-01)

A differential pressure gauge that keeps track of the filter life is installed on the filter itself. This facilitates piping and achieves a compact design.

Specifications

Applicable model	AFF2C to 22C, 37B, 75B
------------------	-------------------------------

How to Order



* Refer to "How to Order" for standard specifications.

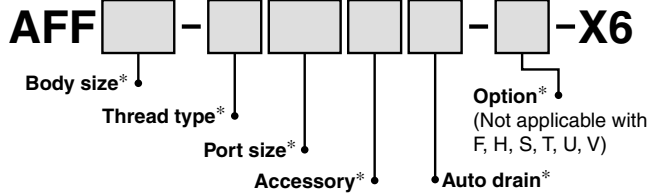

Specifications

Applicable model	AM150C to 550C, 650, 850, AMD150C to 550C, 650, 850, AMH150C to 550C, 650, 850
------------------	---

How to Order



* Refer to "How to Order" for standard specifications.

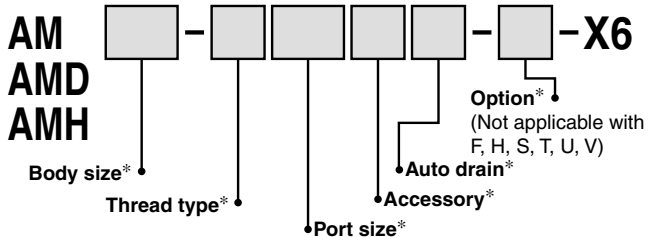

- Note) • The AMG series is not applicable since water drops could ingress inside its differential pressure gauge, resulting in malfunction or damage to the product.
• Cannot be mounted to the AME and AMF series. (It affects the cleanliness at the outlet.)

Dimensions

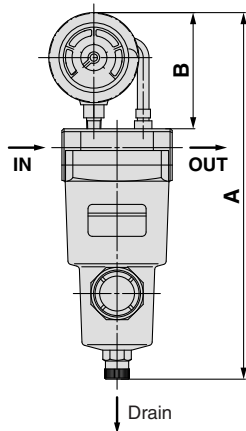

(mm)

AFF series	AM, AMD, AMH series	Port size	A	B
Size	Size			
2C	150C	1/8, 1/4	239	80
4C	250C	1/4, 3/8	252	80
8C	350C	3/8, 1/2	284	80
11C	450C	1/2, 3/4	305	80
22C	550C	3/4, 1	339	80
37B	650	1, 1 1/2	391	80
75B	850	1 1/2, 2	541	80

2. With Differential Pressure Switch (With indicator) (125 VAC, 30 VDC)

Allows visual confirmation of differential pressure which indicates the element life. The built-in contact enables remote control.

Specifications

Applicable model	AFF37B, 75B
------------------	--------------------

How to Order



* Refer to "How to Order" for standard specifications.

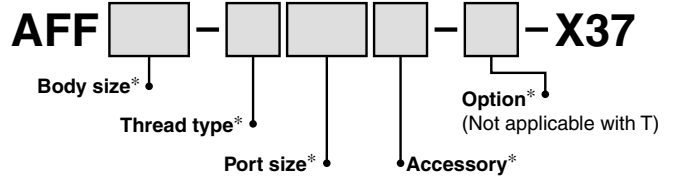

Specifications

Applicable model	AM650, 850, AMD650, 850, AMH650, 850
------------------	---

How to Order



* Refer to "How to Order" for standard specifications.

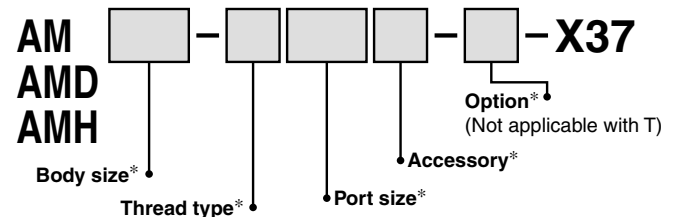

- Note) • The AMG series is not applicable since water drops could ingress inside its differential pressure gauge, resulting in malfunction or damage to the product.

Dimensions

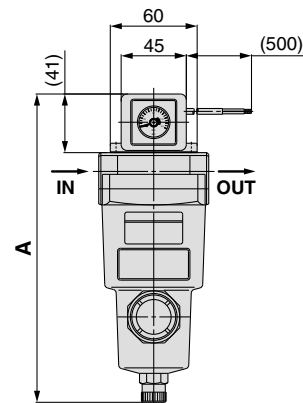

(mm)

AFF series	AM, AMD, AMH series	Port size	A
Size	Size		
37B	650	1, 1 1/2	352
75B	850	1 1/2, 2	501

Compressed Air Cleaning Filter Series

Made to Order 2



Please consult with SMC for detailed specifications, size and delivery.

3. With IN-OUT Flange

Makes flange piping easier when filter ports on IN and OUT are flange connection. (Flange material: Carbon steel)

Specifications

Applicable model	AFF11C, 22C, 37B, 75B
------------------	------------------------------

How to Order * Refer to "How to Order" for standard specifications.

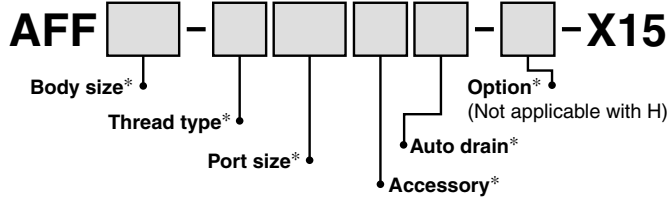

Specifications

Applicable model	AM450C, 550C, 650, 850, AMD450C, 550C, 650, 850, AMH450C, 550C, 650, 850, AMG450C, 550C, 650, 850
------------------	--

How to Order * Refer to "How to Order" for standard specifications.

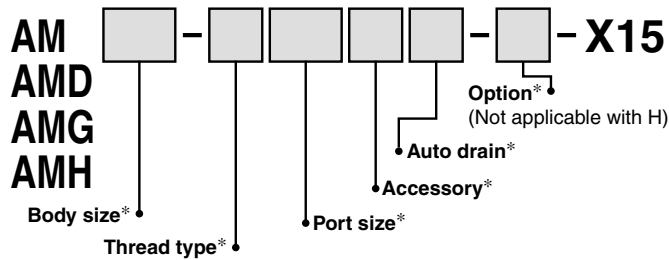

Dimensions

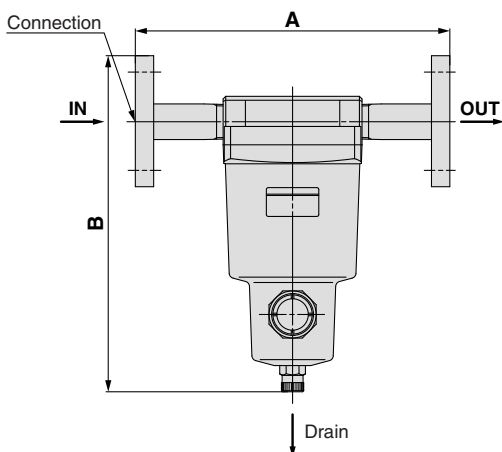

AFF series Size	AM, AMD, AMG, AMH series Size	Connection	(mm)	
			A	B
11C	450C	15(1/2B), 20(3/4B), 25(1B) JIS 10K FF flange	240	255
22C	550C	20(3/4B), 25(1B) JIS 10K FF flange	260	297
37B	650	25(1B), 40(1 1/2B) JIS 10K FF flange	300	349
75B	850	40(1 1/2B), 50(2B) JIS 10K FF flange	380	497

4. With Differential Pressure Gauge (GD40-2-01), IN-OUT Flange

The differential pressure gauge is mounted on the main body to monitor the life of a filter by checking its clogging status. Ports on IN and OUT are flange connection type. (Flange material: Carbon steel)

Specifications

Applicable model	AFF11C, 22C, 37B, 75B
------------------	------------------------------

How to Order * Refer to "How to Order" for standard specifications.

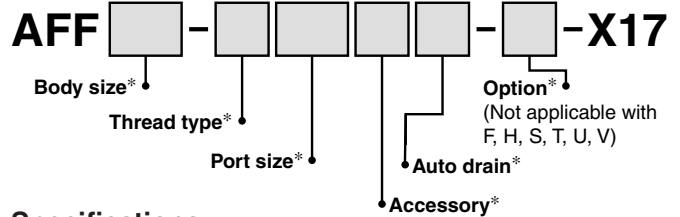

Specifications

Applicable model	AM450C, 550C, 650, 850, AMD450C, 550C, 650, 850, AMH450C, 550C, 650, 850
------------------	---

How to Order * Refer to "How to Order" for standard specifications.

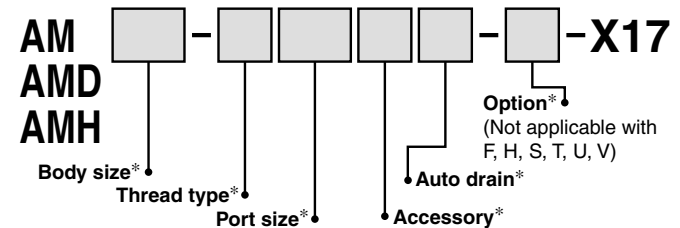

Note) • The AMG series is not applicable since water drops could ingress inside its differential pressure gauge, resulting in malfunction or damage to the product.

Dimensions

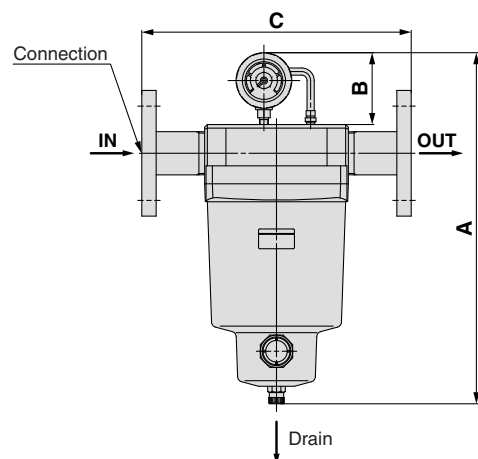

AFF series Size	AM, AMD, AMH series Size	Connection	(mm)		
			A	B	C
11C	450C	15(1/2B), 20(3/4B), 25(1B) JIS 10K FF flange	305	80	240
22C	550C	20(3/4B), 25(1B) JIS 10K FF flange	339		260
37B	650	25(1B), 40(1 1/2B) JIS 10K FF flange	391		300
75B	850	40(1 1/2B), 50(2B) JIS 10K FF flange	541		380

Compressed Air Cleaning Filter Series

Made to Order 3



Please consult with SMC for detailed specifications, size and delivery.

5. N.C., N.O. Auto Drain, Drain Piping Type

Drain piping type (drain guide specification) to the drain exhaust from N.C. auto drain and N.O. auto drain. N.C. type is not available for the AFF37B and AM□650.

Specifications

Applicable model	AFF2C to 22C, 37B
------------------	--------------------------

How to Order * Refer to "How to Order" for standard specifications.

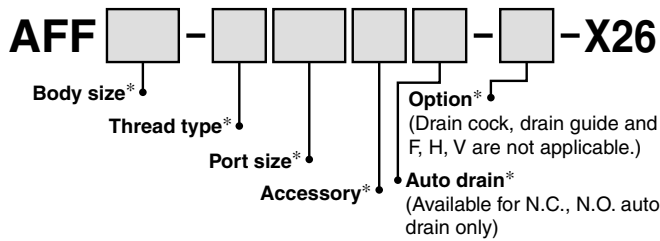

Specifications

Applicable model	AM□150 to 650
------------------	----------------------

How to Order * Refer to "How to Order" for standard specifications.

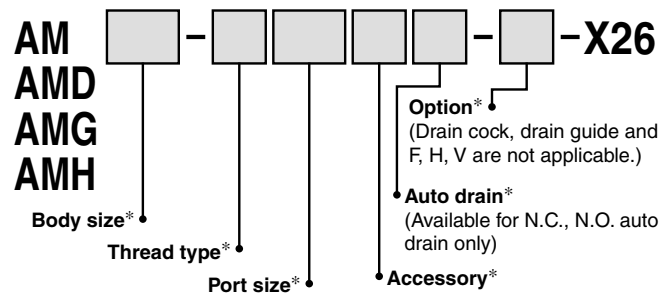

Dimensions

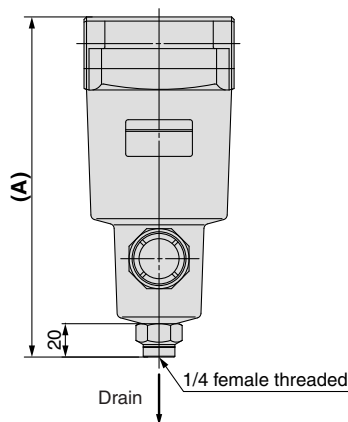

(mm)

AFF series	AM, AMD, AMG, AMH series	Port size	A
Size	Size		
2C	150C	1/8, 1/4	159
4C	250C	1/4, 3/8	172
8C	350C	3/8, 1/2	204
11C	450C	1/2, 3/4	225
22C	550C	3/4, 1	259
37B	650	1, 1 1/2	311

6. White Vaseline Specifications

Changed the grease for O-rings and gaskets as lubricant to white vaseline.

Specifications

Applicable model	AFF37B, 75B
------------------	--------------------

How to Order * Refer to "How to Order" for standard specifications.

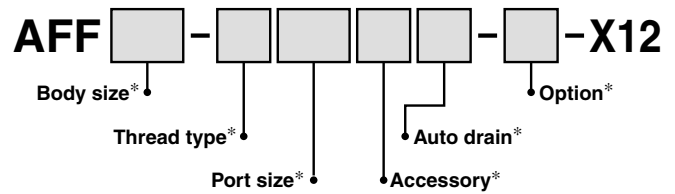

Specifications

Applicable model	AM650, 850, AMD650, 850, AME650, 850, AMF650, 850, AMG650, 850, AMH650, 850
------------------	--

How to Order * Refer to "How to Order" for standard specifications.

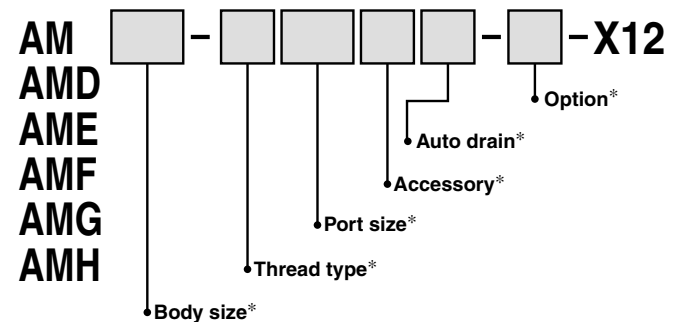

Compressed Air Cleaning Filter Series

Made to Order 4

Please consult with SMC for detailed specifications, size and delivery.



7. Mist Separator for High Flow Rate (0.3 μm)

Use this product when the conventional mist separator (AM series) cannot dispose of a high flow rate. The specifications other than the nominal filtration rating are all equivalent to that of the AFF75A to 220A.

Specifications

Applicable model	AFF75A to 220A
------------------	-----------------------

How to Order



* Refer to "How to Order" for standard specifications.

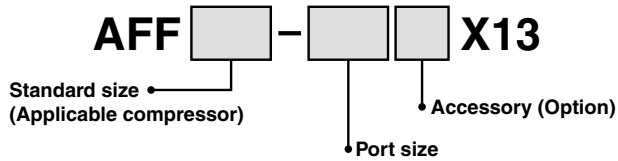

Compressed Air Cleaning Filter Series

Special Specifications

Please consult with SMC for detailed specifications, size and delivery.

Clean Series (10-Series)

Clean Series products are used in cleaner environments such as in clean rooms as compared to a general factory environment. For further details, refer to the Clean Series catalog.

Specifications

Applicable model	AFF2C to 22C, 37B, 75B
------------------	-------------------------------

How to Order  * Refer to "How to Order" for standard specifications.

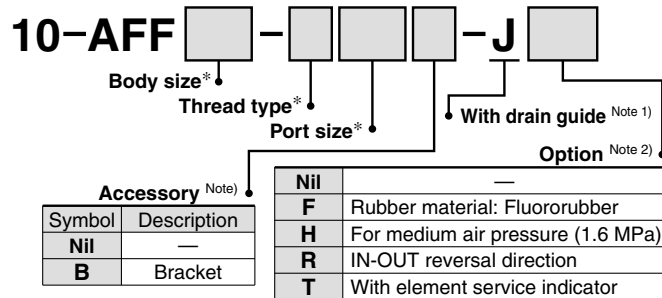

Note 1) "10-" is not applicable to standard product (with drain cock) and with auto drain.

Note 2) Combination of FT is not available.
F and H are only applicable to the AFF2C to 22C.

Specifications

Applicable model	AM150C to 550C, 650, 850, AMD150C to 550C, 650, 850, AMH150C to 550C, 650, 850
------------------	---

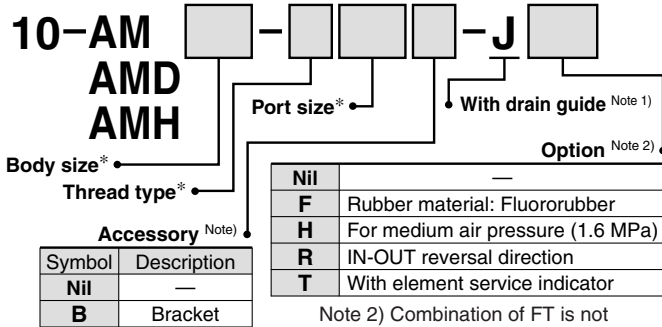

Note 1) "10-" is not applicable to standard product (with drain cock) and with auto drain.

Note 2) Combination of FT is not available.
F and H are only applicable to the AM□150C to 550C.

Specifications

Applicable model	AME150C to 550C, 650, 850, AMF150C to 550C, 650, 850
------------------	---

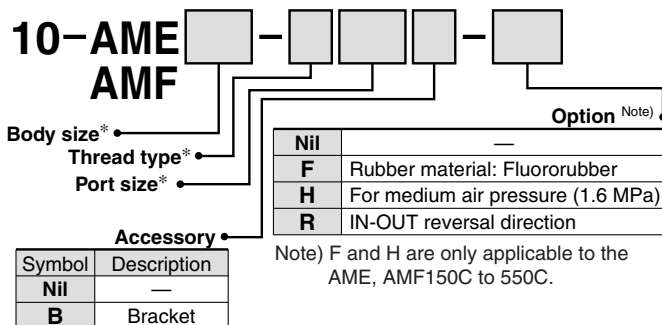

Copper-free, Fluorine-free (20-Series)

To eliminate effects on color CRTs, etc. by copper ion or fluorine resin, copper materials are electroless-nickel plated or changed to copper-free materials to prevent the generation of copper ions. (It is not applicable to the AMD, AME, AMF and AMH series because those include fluorine resin in the filter material of the element.)

Specifications

Applicable model	AFF2C to 22C, 37B
------------------	--------------------------

How to Order  * Refer to "How to Order" for standard specifications.

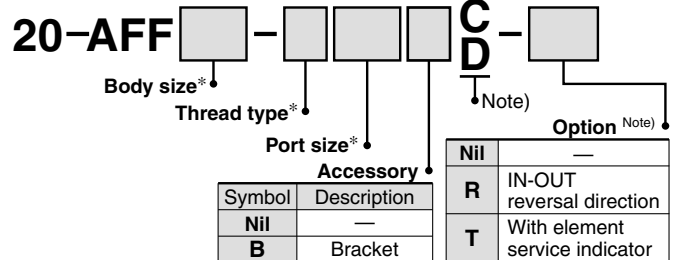

Note) "20-" is only applicable with N.C. auto drain (C) or N.O. auto drain (D). Drain cock and drain guide are copper-free, fluorine-free as standard.

Specifications

Applicable model	AFF75B
------------------	---------------

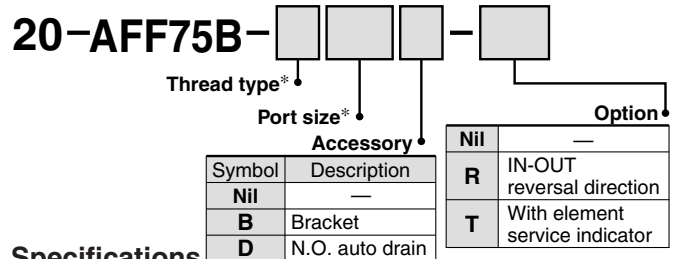

Specifications

Applicable model	AM150C to 550C, 650, AMG150C to 550C, 650
------------------	--

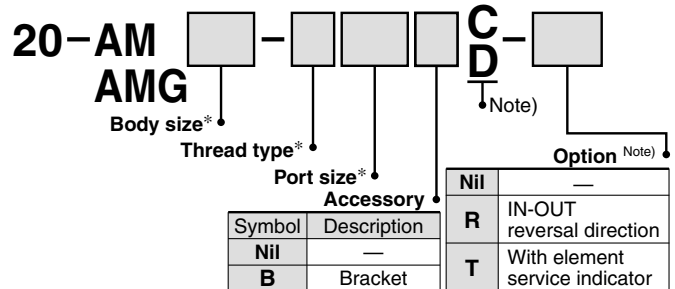

Note) "20-" is only applicable with N.C. auto drain (C) or N.O. auto drain (D). Drain cock and drain guide are copper-free, fluorine-free as standard.

Specifications

Applicable model	AM850, AMG850
------------------	----------------------

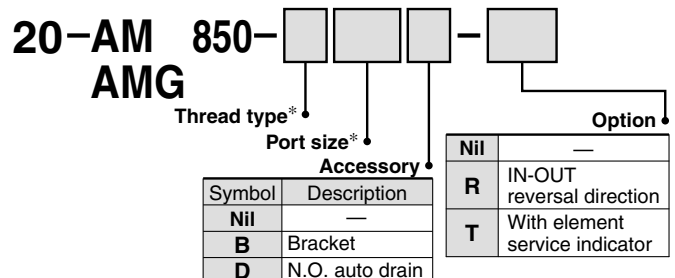

Related Products: Auto Drain Valve

Series AD402/600

Drain is automatically discharged in a reliable manner, without requiring human operators.

Highly resistant to dust and corrosion, operates reliably, and a bowl guard is provided as standard equipment.



AD402



AD600

JIS Symbol

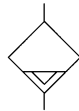

Model/Specifications

Model	AD402	AD600
Proof pressure	1.5 MPa	1.5 MPa
Max. operating pressure	1.0 MPa	1.0 MPa
Operating pressure range ^{Note)}	0.1 to 1.0 MPa	0.3 to 1.0 MPa
Ambient and fluid temperature	-5 to 60°C (No freezing)	-5 to 60°C (No freezing)
Port size	1/4, 3/8, 1/2	3/4, 1
Drain port size	3/8	3/4, 1
Mass (g)	620	2100

Note) 400 ℓ/min (ANR) or more

⚠ Specific Product Precautions

Be sure to read this before handling.

Refer to back pages 1 and 2 for Safety Instructions, "Precautions for Handling Pneumatic Devices" (M-03-E3A) for Common Precautions.

Selection

⚠ Warning

Use the auto drain under the following operating conditions in order to prevent malfunction.

- 1) Operate the compressor above 3.7 kw {400 ℓ/min (ANR)}.
- 2) Use the AD402 at an operating pressure above 0.1 MPa and AD600 above 0.3 MPa.

Piping

⚠ Warning

Piping should be done under the following conditions in order to prevent malfunction.

For drain piping, use a pipe whose I.D. is not less than ø10 and length not more than 5 m. Avoid riser piping.

How to Order

AD402 - [] 03 - []

Thread type

Nil	Rc
N	NPT
F	G

Port size

Symbol	IN	OUT
02	1/4	3/8
03	3/8	3/8
04	1/2	3/8

Option

Nil	—
2	Metal bowl

AD600 - [] 06

Thread type

Nil	Rc
N	NPT
F	G

Port size

Symbol	IN	OUT
06	3/4	3/4
10	1	1

Construction/Dimensions

AD402

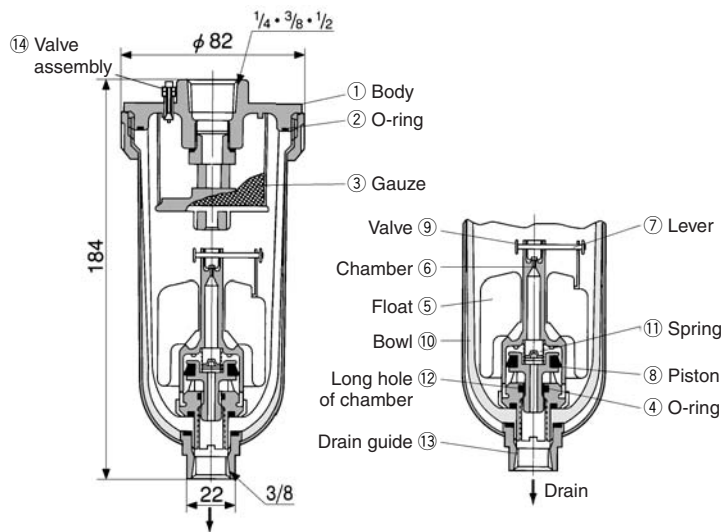

AD600

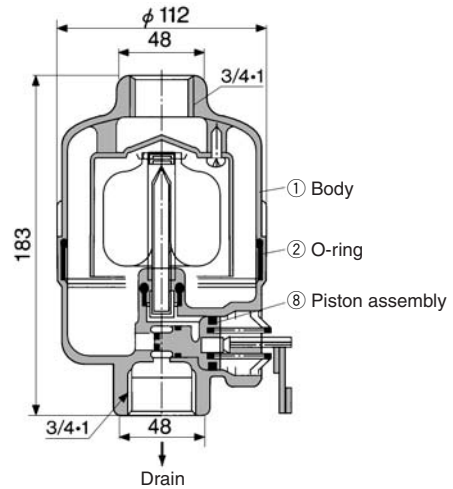

Working Principle (AD402)

- When no pressure is applied inside the bowl ⑩, float ⑤ descends of its own weight and valve ⑨ closes the chamber ⑥ hole. Piston ⑧ is pushed down by spring ⑪, and drain passes through the chamber's long hole ⑫ to enter the housing and is discharged.
- When pressure is applied inside the bowl:
When pressure is 0.1 MPa or more, it overcomes the force of spring ⑪, allowing the piston ⑧ to ascend, and comes in contact with O-ring ④. Thus, the inside of the bowl ⑩ is isolated from the outside.
- When drain has accumulated:
Float ⑤ ascends due to flotation and opens the chamber hole ⑥, allowing the pressure to enter the chamber ⑥. Piston ⑧ descends due to internal pressure and the force of spring ⑪, and the accumulated drain is discharged through drain guide ⑬.

Component Parts

No.	Description	Material
1	Body	Aluminum die-casted

Replacement Parts

No.	Description	Material	Model	
			AD402	AD600
2	O-ring	NBR	113136	JIS B2401G-100
3	Gauze	Stainless steel	20062	—
Note 1)	Internal assembly	—	AD34PA	—
8	Piston assembly	—	—	20025A

Note 1) Internal assembly: Assembly for parts ④ to ⑫ except ⑩.

Note 2) Part no. for bowl assembly: AD34

Note 3) Part no. for bowl ⑩: 201016

Related Products: Motor Operated Auto Drain Series ADM200

Reliably discharges even highly viscous drain

- Highly resistant to dust and highly viscous drain, the valve opens and closes reliably to discharge the drain.

High drain discharge capacity

- With a large discharge port, a large amount of drain can be discharged in a single operation.
- Elimination of residual drain inside the tank and pipes prevents the generation of foreign matter such as dried rust or drain, which could adversely affect the equipment located on the outlet side.

Low power consumption: 4 W

- A long pipe can also be connected to the discharge port.
- Can be connected directly to a compressor.



Model/Specifications

Model	ADM200-□□-□
Fluid	Air
Max. operating pressure	1.0 MPa
Proof pressure	1.5 MPa
Ambient and fluid temperature	-5 to 60°C (No freezing)
Operating cycle*	1 time in a minute (Standard)
Operating time	2 sec./time (Standard)
Power source	100, 200 VAC ^{50/60} Hz, Other
Power consumption	4 W
Port size	IN: 3/8, 1/2
	OUT: 3/8
Mass	550 g

* If the operating cycle is twice in a minute (operating time 2 sec. x 2) operating time is 4 sec. each minute.

⚠ Specific Product Precautions

Be sure to read before handling.

Refer to back pages 1 and 2 for Safety Instructions, "Precautions for Handling Pneumatic Devices" (M-03-E3A) for Common Precautions.

Mounting

⚠ Warning

1. Install this product after discharging the drainage that has already accumulated in the tank. Otherwise, it could lead to malfunction.
2. Install this product, so that the drain port could face downwards. Otherwise, it could lead to malfunction.

⚠ Caution

Provide a stop valve before the ADM200 to facilitate maintenance and inspection.

Piping

⚠ Warning

Piping should be done under the following conditions in order to prevent malfunction. For drain piping, use a pipe whose I.D. is not less than $\phi 5$ and length not more than 5 m. Avoid riser piping.

Maintenance

⚠ Caution

If the valve becomes clogged with debris, press the manual button to flush out the debris. Otherwise, it could lead to malfunction.

How to Order

ADM200 - □ 03 1 - □

Thread type

Nil	Rc
N	NPT
F	G

Port size

Symbol	IN	OUT
03	3/8	3/8
04	1/2	3/8

Operating time/Applicable compressor

Nil	2 sec/min (1 time/min) /3.7 to 37 kW
4	4 sec/min (2 times/min) /37 to 75 kW
6	6 sec/min (3 times/min) /75 to 110 kW
8	8 sec/min (4 times/min) /220 to 370 kW

Voltage

1	100 VAC ^{50/60} Hz
2	200 VAC ^{50/60} Hz
3	240 VAC ^{50/60} Hz
4	110 VAC ^{50/60} Hz
5	220 VAC ^{50/60} Hz
6	24 VDC
7	12 VDC

Mounting Example

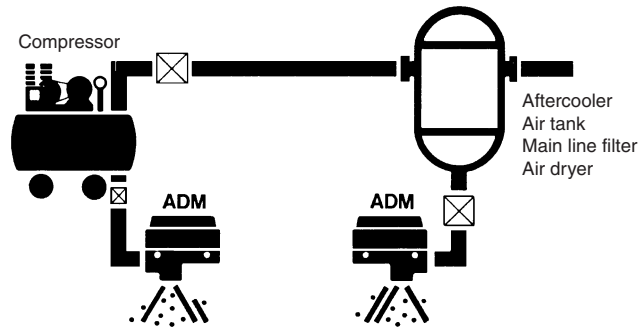

Construction/Dimensions

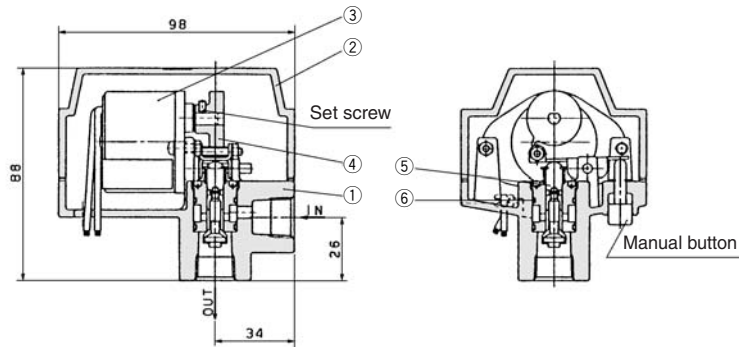

Component Parts

No.	Description	Material	Note
1	Body	Aluminum die-casted	Chrome treated
2	Cap	Aluminum die-casted	Chrome treated

Replacement Parts

No.	Description	Material	Part no.
3 ^{Note)}	Motor	—	812PG-voltage
4	Cam	Cast steel	Operating time 201324 (Nil) 201325 (4) 201326 (6) 201327 (8)
5	Valve assembly	Brass, NBR	20137-1A
6	O-ring	NBR	S-16

Note) Motor part no. in the case of 100 VAC: 812PG-AC100V

Related Products: Heavy Duty Auto Drain Series **ADH4000**

Easy maintenance

Can maintain without removing the existing piping.

No need for electric power and no waste of air.

Float type auto drain allows automatic drain discharge without electric power.

Mounting example

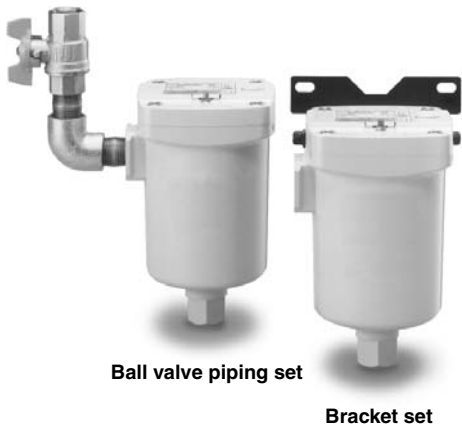
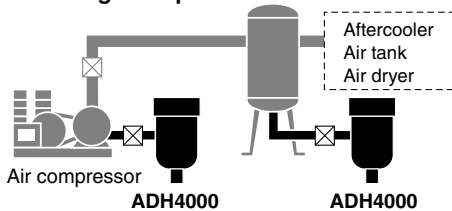

JIS Symbol

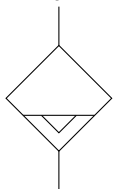

Specifications

Auto drain type	Float type
Auto drain valve type	N.O. (Normally open: Open in the case of pressure loss)
Proof pressure	2.5 MPa
Max. operating pressure	1.6 MPa
Operating pressure range ^{Note)}	0.05 to 1.6 MPa
Fluid	Compressed air
Ambient and fluid temperature	5 to 60°C (With no condensation) <Corrosive gas, flammable gas and organic solvents are not allowed.>
Max. drain discharge	400 cc/min (Pressure 0.7 MPa, in the case of water)
Mass	1.2 kg (With bracket: 1.3 kg)
Paint color	White



Note) Use for an air compressor with flow more than 50 ℓ/min (ANR).

Accessory (Option)

Description	Part no.	Contents
Bracket set	BM58	Bracket 1 pc. M6 x 10 ℓ (Hexagon socket head cap screw) ... 2 pcs.
Ball valve piping set	ADH-C400	Ball valve/Rc 1/2 1 pc. Barrel nipple/R 1/2 2 pcs. Elbow/Rc 1/2 1 pc.



Note) Accessory (Option) is included, but not assembled.

How to Order

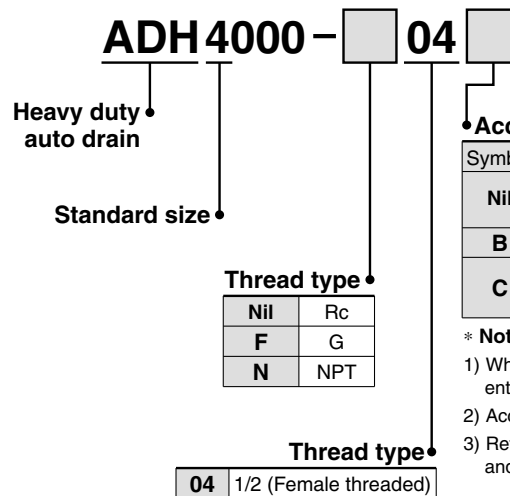

* Notes

- 1) When more than one option is desired, enter in alphabetical order.
- 2) Accessory is not assembled.
- 3) Refer to each drawing of dimensions and mounting methods for details.

Construction

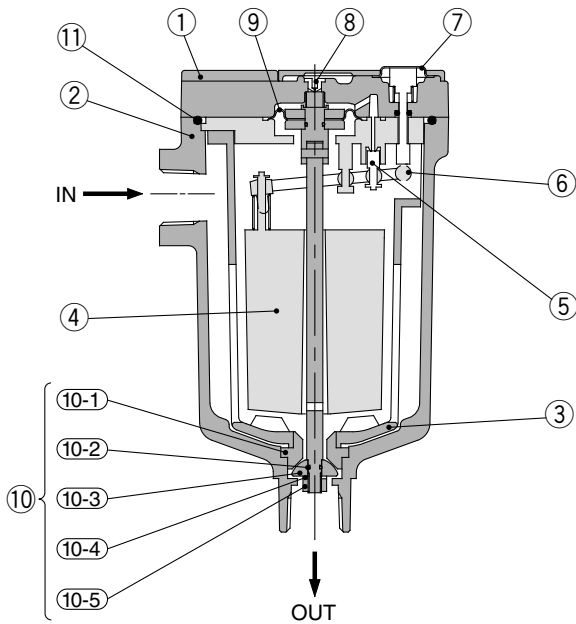

Component Parts

No.	Description	Material	Note
1	Body	Aluminum alloy	Baking finish
2	Housing	Aluminum alloy	Baking finish
3	Drain guard	Aluminum alloy	Baking finish
4	Float	Foam rubber	
5	Pilot valve	Stainless steel + Rubber	
6	Lever	Resin	
7	Flushing button	Brass	
8	Orifice		
9	Diaphragm	Rubber	

Replacement Parts

No.	Description	Part no.	Note
10	Repair kit for main valve	ADH-D400	Kit includes parts from (10-1) to (10-5)
11	O-ring	G85(B)	Material: NBR

Note) When changing parts, follow the operating manual.
Do not disassemble other parts.

⚠ Specific Product Precautions

Be sure to read this before handling. Refer to back pages 1 and 2 for Safety Instructions, "Precautions for Handling Pneumatic Devices" (M-03-E3A) for Common Precautions.

Design

⚠ Caution

- Use this product in an area where the air pressure does not exceed 1.6 MPa.
If exceeding 1.6 MPa, it could lead to an accident or malfunction.
- An air pressure of 0.05 MPa and an air compressor's discharge flow rates higher than 50 ℓ/min (ANR) are required.
Below these values, the air will be exhausted continuously from the drain exhaust port.
- Keep the compressed air and the ambient temperature of the location where this product is installed within the range of 5 to 60°C. Exceeding this range could lead to a failure or malfunction.
- Avoid using this product in an area where corrosive gases, flammable gases or organic solvents are contained in the compressed air or in the surrounding air.

Selection

⚠ Caution

- The maximum dischargeable drainage rate is 400 cc/min.
If using this product in excess of this value, there could be causing the drain to flow over to the outlet side.

Piping

⚠ Caution

- Use piping of 1/2^B or larger for drain inlet and avoid riser piping.
- For drain piping, use a pipe whose I.D. is not less than 8 mm and length not more than 10 m. Do not make any upward angles in drain line. Be sure to secure exhaust port piping since drain is under pressure.

Mounting

⚠ Caution

- Install with "out port" down in a vertical position.
Inclination from the vertical line should be less than 5°.
- Install with at least 200 mm of free space above the unit to allow for maintenance.
- To place this product near the air compressor, install in such a way that the vibrations will not be transmitted.
- Install a valve to drain inlet so that maintenance is possible.
Use a ball valve with a bore size of more than 15 mm. (Ball valve piping set is available as an accessory (option).)

Mounting

⚠ Caution

- When not draining sufficiently, open the bleed valve so that drain could run through easily.

Maintenance

⚠ Caution

- Check drain condition periodically (more than once a day).
Also, push the flushing button to open the exhaust valve.
- Pilot air is exhausted from the exhaust port indicated in "Dimensions". Do not cover this exhaust port. Clean the exhaust port so that port is not blocked by dust, etc.
- When solid foreign objects exceeding 1 mm come in, the main valve may become blocked. After recovering the internal pressure of this product to 0 MPa (atmospheric pressure), remove the hexagon socket head cap screw (M6) from the body part and wash inside with water to remove foreign solid objects blocking the main valve.
- When using this product, drain may not easily enter the product. In such a case, adjust the open angle of its bleed valve to lower the pressure a bit inside the bowl so that drain could run through easily.

Series ADH4000

Dimensions

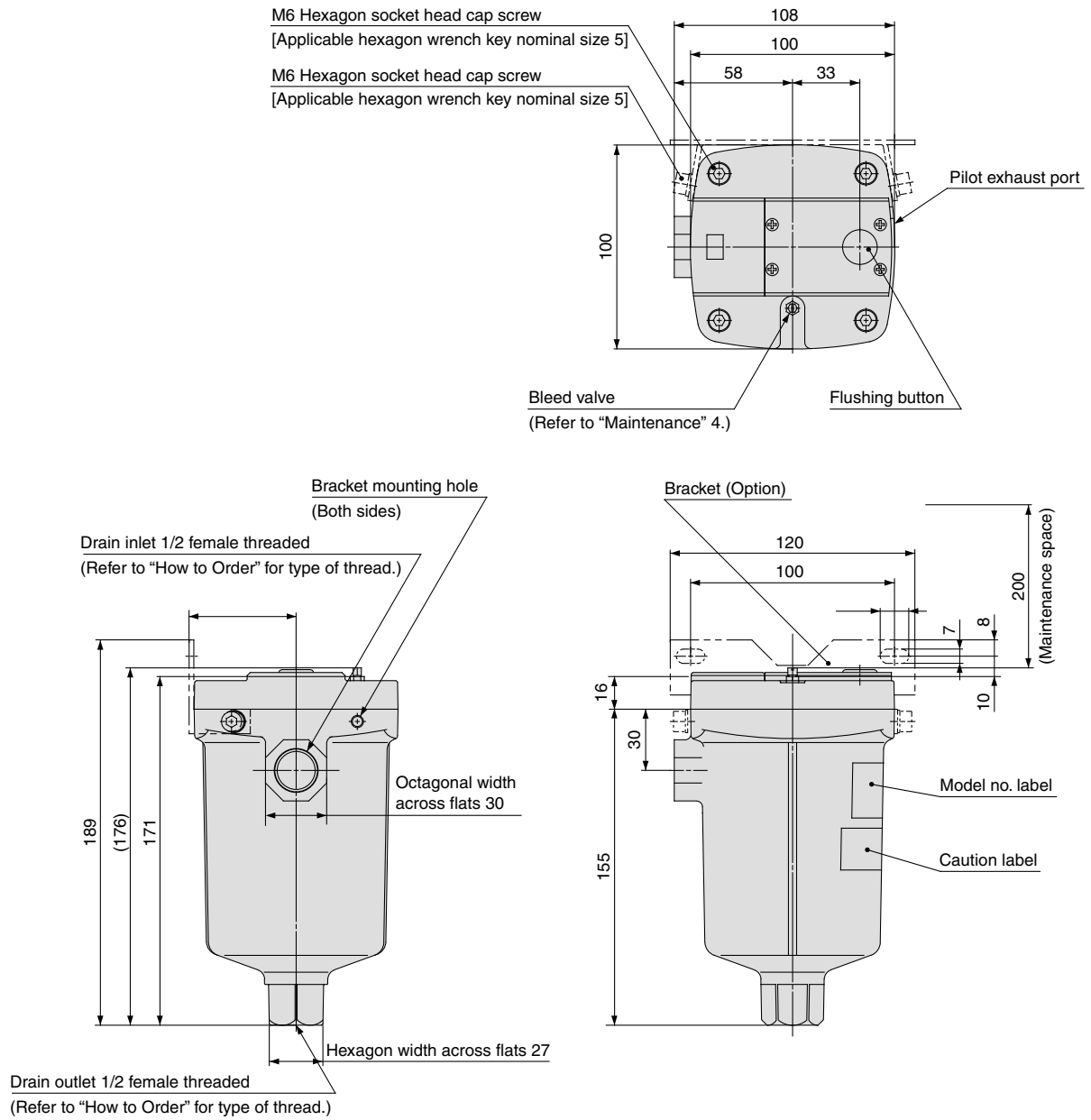

Option: Reference Figure of Assembly

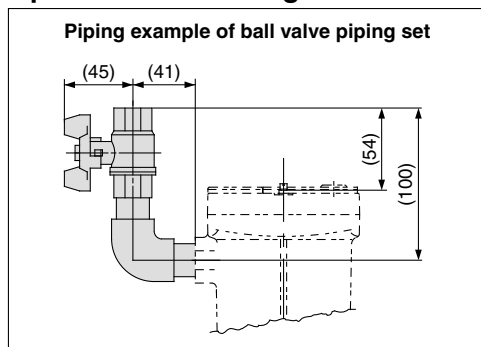

Related Products: Differential Pressure Gauge Series *GD40-2-01*

The pressure differential at the inlet and the outlet of compressed air equipment can be viewed at a glance on the differential pressure gauge. It is ideal for the maintenance control of filters.

Compact and lightweight
Can be installed easily by merely providing a bypass circuit.
Provided with a protective cover to prevent hazards.



JIS Symbol



Piping Example

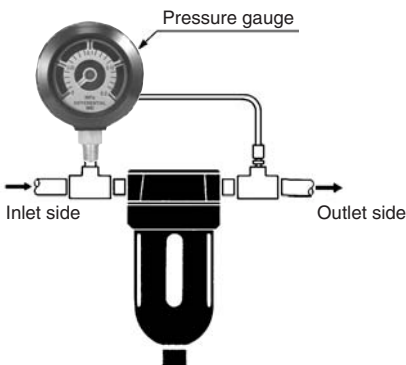

Model/Specifications

Model	GD40-2-01
Fluid	Compressed air
Max. operating pressure	1 MPa
Proof pressure	1.5 MPa
Ambient and fluid temperature	5 to 60°C
Port size Rc	1/8
Scale range	0 to 0.2 MPa
Accuracy	±0.006 MPa
Dial size	ø40
Mass (g)	300

Main Parts Material

Case	Zinc die-casted
Internal part	Brass, Phosphor bronze
Window	Polyester
Scale plate	Stainless steel

Accessory

Nylon tube	T0425 (0.5 m)
Male connector	H04-01 (1 pc.)
Male elbow	DL04-01 (1 pc.)

⚠ Specific Product Precautions

Be sure to read this before handling.

Refer to back pages 1 and 2 for Safety Instructions, "Precautions for Handling Pneumatic Devices" (M-03-E3A) for Common Precautions.

Design

⚠ Caution

1. This product cannot be used in a location where pulsations could occur frequently.

Mounting

⚠ Caution

1. Mounting
 - 1) The HIGH and LOW marks on the back of the differential pressure gauge indicate the high pressure and low pressure sides respectively. Connect the HIGH side to the inlet side of the filter or other devices and the LOW side to their outlet side. Do not use a stop valve to prevent damage to the differential pressure gauge if the valve is inadvertently left open or closed.
 - 2) Install the differential pressure gauge vertically.
 - 3) The piping of the differential pressure gauge must be connected securely because it will break if it becomes detached.

Dimensions

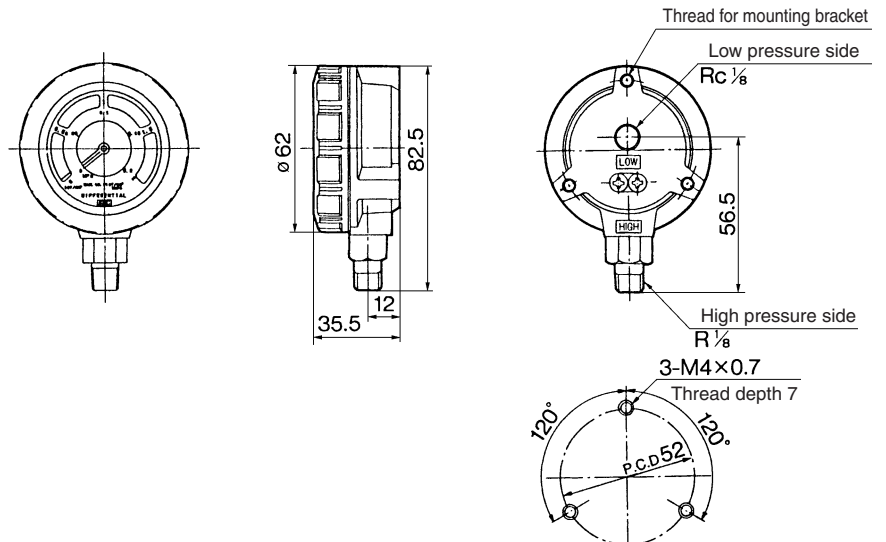





Safety Instructions

These safety instructions are intended to prevent hazardous situations and/or equipment damage. These instructions indicate the level of potential hazard with the labels of “**Caution**,” “**Warning**” or “**Danger**.” They are all important notes for safety and must be followed in addition to International Standards (ISO/IEC), Japan Industrial Standards (JIS)*1) and other safety regulations*2).

- * 1) ISO 4414: Pneumatic fluid power – General rules relating to systems.
ISO 4413: Hydraulic fluid power – General rules relating to systems.
IEC 60204-1: Safety of machinery – Electrical equipment of machines. (Part 1: General requirements)
ISO 10218-1992: Manipulating industrial robots -Safety.
JIS B 8370: General rules for pneumatic equipment.
JIS B 8361: General rules for hydraulic equipment.
JIS B 9960-1: Safety of machinery – Electrical equipment of machines. (Part 1: General requirements)
JIS B 8433-1993: Manipulating industrial robots - Safety.
etc.
- * 2) Labor Safety and Sanitation Law, etc.

 **Caution:** Operator error could result in injury or equipment damage.

 **Warning:** Operator error could result in serious injury or loss of life.

 **Danger :** In extreme conditions, there is a possibility of serious injury or loss of life.

Warning

1. The compatibility of the product is the responsibility of the person who designs the equipment or decides its specifications.

Since the product specified here is used under various operating conditions, its compatibility with specific equipment must be decided by the person who designs the equipment or decides its specifications based on necessary analysis and test results. The expected performance and safety assurance of the equipment will be the responsibility of the person who has determined its compatibility with the product. This person should also continuously review all specifications of the product referring to its latest catalog information, with a view to giving due consideration to any possibility of equipment failure when configuring the equipment.

2. Only personnel with appropriate training should operate machinery and equipment.

The product specified here may become unsafe if handled incorrectly. The assembly, operation and maintenance of machines or equipment including our products must be performed by an operator who is appropriately trained and experienced.

3. Do not service or attempt to remove product and machinery/equipment until safety is confirmed.

1. The inspection and maintenance of machinery/equipment should only be performed after measures to prevent falling or runaway of the driven objects have been confirmed.

2. When the product is to be removed, confirm that the safety measures as mentioned above are implemented and the power from any appropriate source is cut, and read and understand the specific product precautions of all relevant products carefully.

3. Before machinery/equipment is restarted, take measures to prevent unexpected operation and malfunction.

4. Contact SMC beforehand and take special consideration of safety measures if the product is to be used in any of the following conditions.

1. Conditions and environments outside of the given specifications, or use outdoors or in a place exposed to direct sunlight.

2. Installation on equipment in conjunction with atomic energy, railways, air navigation, space, shipping, vehicles, military, medical treatment, combustion and recreation, or equipment in contact with food and beverages, emergency stop circuits, clutch and brake circuits in press applications, safety equipment or other applications unsuitable for the standard specifications described in the product catalog.

3. An application which could have negative effects on people, property, or animals requiring special safety analysis.

4. Use in an interlock circuit, which requires the provision of double interlock for possible failure by using a mechanical protective function, and periodical checks to confirm proper operation.



Safety Instructions

Caution

The product is provided for use in manufacturing industries.

The product herein described is basically provided for peaceful use in manufacturing industries.

If considering using the product in other industries, consult SMC beforehand and exchange specifications or a contract if necessary. If anything is unclear, contact your nearest sales branch.

Limited Warranty and Disclaimer/Compliance Requirements

The product used is subject to the following “Limited Warranty and Disclaimer” and “Compliance Requirements”. Read and accept them before using the product.

Limited Warranty and Disclaimer

1. The warranty period of the product is 1 year in service or 1.5 years after the product is delivered.*3)

Also, the product may have specified durability, running distance or replacement parts. Please consult your nearest sales branch.

2. For any failure or damage reported within the warranty period which is clearly our responsibility, a replacement product or necessary parts will be provided.

This limited warranty applies only to our product independently, and not to any other damage incurred due to the failure of the product.

3. Prior to using SMC products, please read and understand the warranty terms and disclaimers noted in the specified catalog for the particular products.

*** 3) Vacuum pads are excluded from this 1 year warranty.**

A vacuum pad is a consumable part, so it is warranted for a year after it is delivered.

Also, even within the warranty period, the wear of a product due to the use of the vacuum pad or failure due to the deterioration of rubber material are not covered by the limited warranty.

Compliance Requirements

When the product is exported, strictly follow the laws required by the Ministry of Economy, Trade and Industry (Foreign Exchange and Foreign Trade Control Law).



Series AM□/AFF Specific Product Precautions 1

Be sure to read this before handling. Refer to back pages 1 and 2 for Safety Instructions, and "Precautions for Handling Pneumatic Devices" (M-03-E3A) for Common Precautions.

Design

⚠ Caution

1. Design the layout so that the mist separator should be installed in an area that is less susceptible to pulsations.

The element could be damaged if a difference between the inlet pressure and the outlet pressure exceeds 0.1 MPa.

2. Be careful of dust generation by the pneumatic equipment mounted on the outlet side.

When installing pneumatic equipment on the outlet side of the AM□ series, dust particles may come off from outlet equipment, which will lower the cleanliness of compressed air. Consider this impact upon the cleanliness of compressed air when installing pneumatic equipment on the outlet side.

3. About when to use N.C. auto drain and N.O. auto drain.

When using the AFF2C to 22C, 37B, 75B, AM□150C to 550C, 650, 850 with normally open (N.O.) auto drain, air may ceaselessly blow out of the drain discharge area when an air compressor with a small air discharge volume is used since the valve does not close unless the air pressure is 0.1 MPa or higher. Therefore, when using a compressor for 3.7 kW or less, make sure to use the normally closed (N.C.) auto drain. The minimum operating pressure is 0.15 MPa even with N.C. auto drain.

4. Use a tubing with proper size and length for drain piping of auto drain.

When using the AFF2C to 22C, 37B, AM□150C to 550C, 650 with auto drain:

Normally closed (N.C.) } Use tubing O.D. 10 mm and keep
Normally open (N.O.) } the whole length within 5 m.

When using the AFF75B and AM□850 with auto drain:

Normally open (N.O.): Use tubing I.D. 9 mm or more and keep the whole length within 2.8 m.

5. Provide a design that prevents back pressure and back flow.

Back pressure or back flow may damage an element.

6. Keep the certificate of Class 2 Pressure Vessel in a safe place.

Products below are subject to Class 2 Pressure Vessel Act. Certificate will be sent in 2 to 4 weeks later after the shipment of the product.

Main Line Filter AFF220A

Micro Mist Separator AMD9□0/10□0/9□1

⚠ Warning

1. Hold the female thread side and tighten to the recommended torque when screwing in the piping material.

Insufficient tightening torque may cause loosening or defective sealing. Over-tightening torque may damage the thread etc. If it is tightened without holding the female thread side, excessive force will be directly applied to the piping bracket resulting in a product failure.

Recommended Torque

Unit: N·m

Connection thread	1/8	1/4	3/8	1/2	3/4	1	1 1/2	2
Torque	1.5 to 2	7 to 9	12 to 14	28 to 30	28 to 30	36 to 38	48 to 50	48 to 50

* After tightening manually, tighten additionally by about 1/6 turn with a tightening tool.

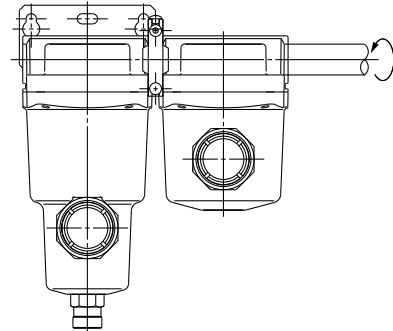

2. Do not apply torsional moment or bending moment (except the product's own weight) to the bracket. It may damage the bracket. Support external piping separately.

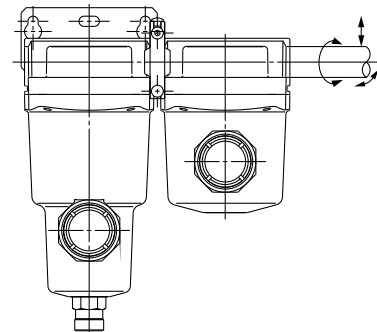

3. Inflexible piping such as steel piping tends to be affected by spread of excessive moment load or vibration from the piping side. Lay flexible tubing between the steel pipe and the product to prevent such effects.



Series AM□/AFF Specific Product Precautions 2

Be sure to read this before handling. Refer to back pages 1 and 2 for Safety Instructions, and “Precautions for Handling Pneumatic Devices” (M-03-E3A) for Common Precautions.

Selection

⚠ Caution

1. About the system composition of purifying compressed air

Compressed air generally contains particulate contaminants as listed below, though there are some variations due to the compressor type and specifications. Determine the system configuration according to the desired cleanliness of compressed air and application, while referring to the “Air Preparation Equipment Selection Guide” for the AM□ series (Best Pneumatics).

[Particulate contaminants in compressed air]

- Water (drainage)
- Dust sucked from ambient air
- Degenerated oil from compressor
- Solid foreign matter such as rust inside piping and oil

2. Select according to the maximum flow consumption.

When compressed air is used for air blow, etc., find the maximum air consumption before selecting the size of the AM□ series. (If compressed air exceeding the maximum flow rate is supplied, it can result in decline of the cleanliness of compressed air or element damage.)

Mounting

⚠ Caution

1. About the mounting orientation of the products

Make sure to install this product on horizontal piping. If it is installed diagonally, laterally, or upside down, the drain separated by the element will splash to the outlet side.

Piping

⚠ Caution

1. Connect it with IN and OUT ports in proper location. It does not work with the connection reversed.

In the case of the AFF2C to 22C, 37B, 75B, AM□150C to 550C, 650, 850

Verify the direction of the flow of the compressed air and the “⇨” or “▷” mark that indicates the inlet of the product before connecting. It cannot be used if connected in the opposite direction.

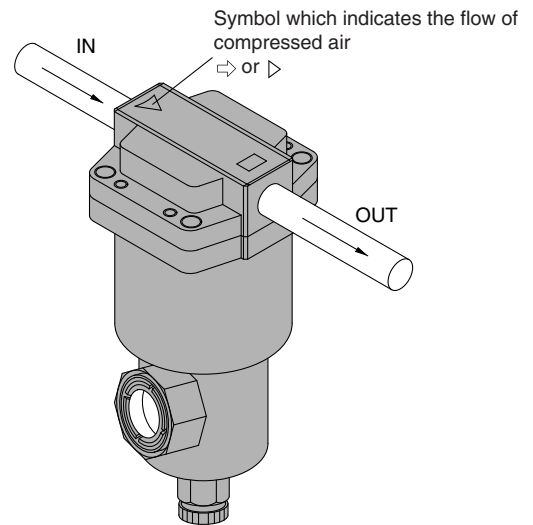

In the case of the AFF75A to 220A, AMD801, 901, 800, 900, 1000

INLET and OUTLET of compressed air is labeled on the side of flange. Be sure to connect correctly.

2. Use an air blower to flush the piping before connecting the piping.

Use an air blower to thoroughly flush the piping, or wash the piping to remove any cutting chips, cutting oil, or debris from inside the piping before connecting them.

3. Wrapping of sealant tape

When screwing in the pipes or fittings, make sure to prevent cutting chips or the sealant material on the threaded portion of the pipe from entering the piping. If sealant tape is to be used, leave about 1.5 to 2 ridges of threads uncovered.

4. Modular connection

Mount the attached bracket on one side when connecting 2 sets. Mount the attached brackets on both sides when connecting 3 sets or more. As a guideline for the number of brackets, one bracket should be mounted for every 2 products.



Series AM□/AFF Specific Product Precautions 3

Be sure to read this before handling. Refer to back pages 1 and 2 for Safety Instructions, and "Precautions for Handling Pneumatic Devices" (M-03-E3A) for Common Precautions.

Air Supply

⚠ Caution

1. The mist separator is not applicable to gases other than compressed air.

The mist separator is not applicable to gases other than compressed air (example: oxygen, hydrogen, flammable gas, mixed gas).

2. Do not use compressed air that contains chemicals, organic solvents, salt, or corrosive gases.

Do not use compressed gas containing chemicals, organic solvents, salt or corrosive gas. This can cause rust, damage to rubber and resin parts, or malfunction.

3. Operate within the specified operating pressure range.

Damage, failure, or malfunction may occur if the mist separator is operated above the maximum operating pressure.

If the mist separator is used below the minimum operating pressure, increase in the air-flow resistance due to clogging will have such influence that the desired flow rate cannot be obtained.

If the mist separator is used under a low pressure such as for a blower, conduct sufficient tests by users to confirm the specifications and performances.

Operating Environment

⚠ Caution

1. Do not use in the following environments, as this can cause failure.

- 1) In locations having corrosive gases, organic solvents, and chemical solutions, or in locations where these elements are likely to adhere to the equipment.
- 2) In locations where salt water, water, or water vapor could come in contact with the equipment.
- 3) In locations that is exposed to shocks and vibrations.

2. Be careful about the contamination of the workpieces due to entrainment of the ambient air.

If compressed air is used for air blow, compressed air blowing out from the blow nozzle may entrain foreign matter (solid particles and liquid particles) floating in the ambient air, blowing it against the workpieces and causing adhesion. Therefore, sufficient precautions must be taken about the ambient environment.

Maintenance

⚠ Caution

1. Replace the element immediately when the time for its replacement has arrived.

To replace the element, replace the O-ring and the gasket, too. For the replacement procedure, refer to the operating manual. (For element dimensions, refer to back page 6.)

<Element replacement>

In the case of the AFF2C to 22C, 37B, 75B, AM□150C to 550C, 650, 850

The replacement interval for the element is when the pressure drop reaches 0.1 MPa or after two years of operation, whichever comes first. A pressure drop can be verified with the element service indicator (-T) or with differential pressure gauge (Made to Order).

In the case of the AFF75A to 220A, AMD800 to 1000, AMD801, 901

The replacement interval for the element is when the pressure drop reaches 0.1 MPa or after one year of operation, whichever comes first. Confirm the pressure drop with a pressure gauge. (With pressure gauge: -G)

2. Be sure to exhaust the drain accumulated in the filter container.

Failure to discharge the drain will allow the accumulated drain to flow over to the outlet side.

When using the AFF2C to 22C, 37B, 75B, AM□150C to 550C, 650, 850 with drain cock, drain guide or ball valve, discharge the drain before the drainage level reaches the center of the sight glass. If the drain is not discharged properly, it will flow over to the outlet side.

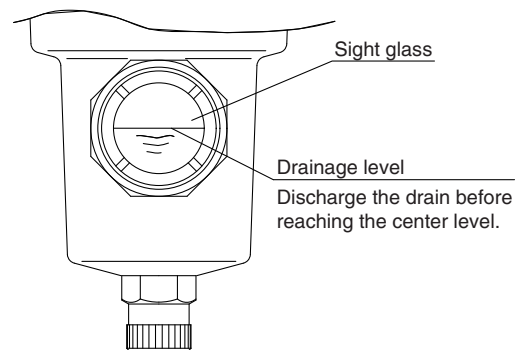



Series AM□/AFF Specific Product Precautions 4

Be sure to read this before handling. Refer to back pages 1 and 2 for Safety Instructions, and "Precautions for Handling Pneumatic Devices" (M-03-E3A) for Common Precautions.

Maintenance

⚠ Caution

3. In the case of a type with auto drain

- The auto drain operates when the drainage level reaches the top of the sight glass, and the drain will be discharged.
- When using the AFF2C to 22C, 37B, AM□150C to 550C, 650 with auto drain, the drain is automatically discharged with the knob tightened to the "S" side. Manual drain discharge, however, is also possible.

<Manual operation>

A manual knob attached to the auto drain end is tightened to the "S" side in normal operation. The drain can be discharged by loosening it to the "O" side. (Be careful, however, if pressure remains inside the filter when the drain is discharged, the drain will blow out from the drain port.)

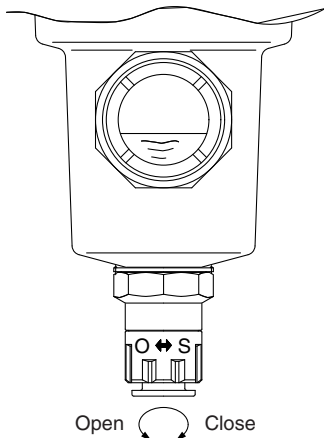

4. The drain exhaust parts replacement method and necessary parts are different depending on when it was manufactured.

Description	Necessary parts		Applicable size
	Manufactured Dec. 2002 or before [Up to manufacturing lot No. GZ]	Manufactured Jan. 2003 onwards [Manufacturing lot No. HO onwards]	
Drain cock	AM-SA002		2C to 22C 2B to 37B 150C to 550C 150 to 650
Drain guide	AM-SA003		
N.O. auto drain	Auto drains cannot be replaced alone since those cannot be assembled without dedicated assembly tools. The entire bowl assembly must be replaced. (Refer to "How to Order Bowl Assembly" on page 63.)	AD43PA-D	
N.C. auto drain		AD53PA-D	
Ball valve set	AM-SA004		75B, 850
N.O. auto drain	AD34PA-D ^{Note)}		

Note) Jig (AM-SA005) for replacing auto drain is necessary for the 75B or 850.

Others

⚠ Caution

1. Element interchange

Following is the element dimensions for the AFF and AM□ series:

Since elements for the same body size has the same dimensions, they are interchangeable.

However, do not interchange them easily since it can cause various kinds of problems.

If interchanging the elements is unavoidable, replace the product model number label, too.

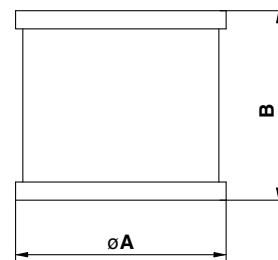

Element Dimensions

Model	Element dimensions (Reference value)	
	ϕA	B
AFF2C, AFF2B, AM150C, AM150 AMD150C, AMD150, AMH150C, AMH150	49	42
AFF4C, AFF4B, AM250C, AM250 AMD250C, AMD250, AMH250C, AMH250	58	52
AFF8C, AFF8B, AM350C, AM350 AMD350C, AMD350, AMH350C, AMH350	70	78
AFF11C, AFF11B, AM450C, AM450 AMD450C, AMD450, AMH450C, AMH450	82	88
AFF22C, AFF22B, AM550C, AM550 AMD550C, AMD550, AMH550C, AMH550	96	118
AFF37B, AM650 AMD650, AMH650	122	144
AFF75B, AM850 AMD850, AMH850	142	223

2. About oil-free products

The AFF and AM□ series includes parts (such as resin parts, rubber parts, and elements) that does not allow degreasing wash. Therefore, oil-free products with all parts degreasing washed is not available.

3. Degreasing wash

Certain parts such as the body and housing can be degreasing washed. Contact SMC after confirming the specifications. (available as Option or Made to Order)

4. Change of oil

On the AFF and AM□ series, no oil such as grease is applied to parts exposed to compressed air. However, for certain specifications, there are some parts to which oil is applied. It is possible to change the type of applied oil (as Option or Made to Order).



Series AM□/AFF Specific Product Precautions 5

Be sure to read this before handling. Refer to back pages 1 and 2 for Safety Instructions, and "Precautions for Handling Pneumatic Devices" (M-03-E3A) for Common Precautions.

Others

⚠ Caution

5. Internal volume of filter container

The product can be used as a small capacity air tank by removing the element.

Following is the volume of filter containers of the AFF and AM□ series (when the element is removed).

Volume Inside Filter

Model	Volume inside filter (Reference value) (cm ³)
AFF2C, AFF2B, AM150C, AM150 AMD150C, AMD150, AMH150C, AMH150	250
AFF4C, AFF4B, AM250C, AM250 AMD250C, AMD250, AMH250C, AMH250	300
AFF8C, AFF8B, AM350C, AM350 AMD350C, AMD350, AMH350C, AMH350	600
AFF11C, AFF11B, AM450C, AM450 AMD450C, AMD450, AMH450C, AMH450	1000
AFF22C, AFF22B, AM550C, AM550 AMD550C, AMD550, AMH550C, AMH550	1500
AFF37B, AM650 AMD650, AMH650	3000
AFF75B, AM850 AMD850, AMH850	9000

Discontinued Model and Equivalent Model

The AFF and AM□ series were remodeled to products introduced in this catalog in 1988.

Along with the new models, old models were provided mainly for the purpose of maintenance. However, due to the aging of metal dies and extreme decline in the quantity, the procurement of parts and consequently the maintenance of the production system became difficult. For this reason, old models were discontinued in 1994, as detailed in the table below. Use the equivalent model listed there.

Discontinued Model and Equivalent Model

Product name	Production discontinuance			Equivalent model			Page						
	Model	Period of production discontinuance for products	Period of production discontinuance for maintenance parts	External dimensions of product Width x Depth x Height	Model	External dimensions of product Width x Depth x Height							
Main Line Filter	AFF6	End of July '94	End of March '99	100 x 100 x 253	AFF4C	76 x 76 x 172	P.10						
	AFF22			150 x 140 x 446	AFF22C	122 x 122 x 259							
	AFF37			200 x 170 x 526	AFF37B	160 x 160 x 311							
	AFF55			280 x 280 x 497	AFF75B	220 x 220 x 461							
Mist Separator	AM200			End of July '94	End of March '99	63 x 63 x 191	AM150C	63 x 63 x 158	P.18				
	AM300					85 x 85 x 258	AM250C	76 x 76 x 172					
	AM400					120 x 120 x 236	AM350C	90 x 90 x 204					
	AM500					140 x 140 x 383	AM550C	122 x 122 x 259					
Micro Mist Separator	AM600					End of July '94	End of March '99	180 x 170 x 465	AM650	160 x 160 x 311	P.26		
	AMD100							63 x 63 x 136	AMD150C	63 x 63 x 158			
	AMD200							80 x 82 x 170	AMD250C	76 x 76 x 172			
	AMD300							90 x 90 x 233	AMD350C	90 x 90 x 204			
Odor Removal Filter	AMD400							End of July '94	End of March '99	140 x 140 x 380	AMD450C	106 x 106 x 225	P.52
	AMD500									140 x 140 x 490	AMD550C	122 x 122 x 259	
	AMD600									140 x 140 x 590	AMD650	160 x 160 x 311	
	AMF200									80 x 80 x 153	AMF250C	76 x 76 x 103	
	AMF300	End of July '94	End of March '99							90 x 90 x 216	AMF350C	90 x 90 x 132	P.52
	AMF400									140 x 140 x 250	AMF450C	106 x 106 x 151	
	AMF500									140 x 140 x 360	AMF550C	122 x 122 x 187	
	AMF600									140 x 140 x 460	AMF650	160 x 160 x 291	

Note) Some models have different heights depending on the port size. They are shown in parentheses.

SMC'S GLOBAL MANUFACTURING, DISTRIBUTION AND SERVICE NETWORK

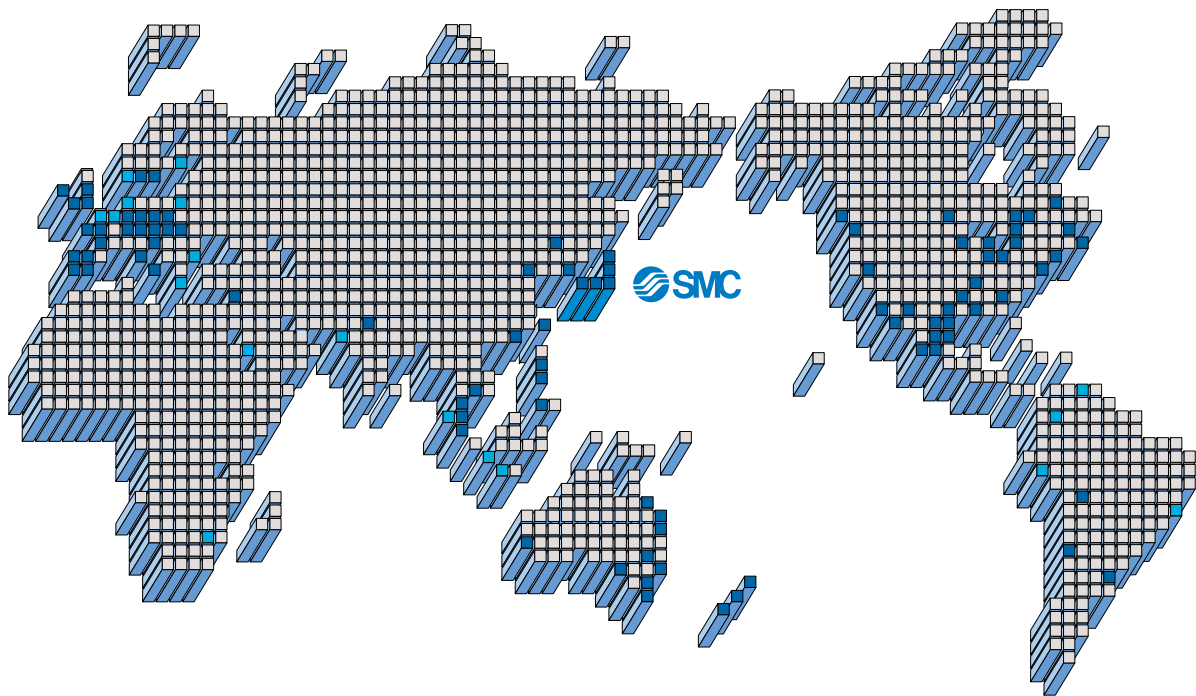

EUROPE

AUSTRIA

SMC Pneumatik GmbH (Austria)

BELGIUM

SMC Pneumatics N.V./S.A.

BULGARIA

SMC Industrial Automation Bulgaria Eood

CROATIA

SMC Industrijska Automatika d.o.o.

CZECH REPUBLIC

SMC Industrial Automation CZ s.r.o.

DENMARK

SMC Pneumatik A/S

ESTONIA

SMC Pneumatics Estonia OÜ

FINLAND

SMC Pneumatics Finland Oy

FRANCE

SMC Pneumatique SA

GERMANY

SMC Pneumatik GmbH

GREECE

SMC Hellas E.P.E.

HUNGARY

SMC Hungary Ipari Automatizálási Kft.

IRELAND

SMC Pneumatics (Ireland) Ltd.

ITALY

SMC Italia S.p.A.

LATVIA

SMC Pnuematics Latvia SIA

LITHUANIA

UAB "SMC Pneumatics"

NETHERLANDS

SMC Pneumatics B.V.

NORWAY

SMC Pneumatics Norway AS

POLAND

SMC Industrial Automation Polska Sp.z.o.o.

ROMANIA

SMC Romania S.r.l.

RUSSIA

SMC Pneumatik LLC

SLOVAKIA

SMC Priemyselná Automatizácia Spol s.r.o.

SLOVENIA

SMC Industrijska Avtomatika d.o.o.

SPAIN/PORTUGAL

SMC España S.A.

SWEDEN

SMC Pneumatics Sweden AB

SWITZERLAND

SMC Pneumatik AG

U.K.

SMC Pneumatics (U.K.) Ltd.

ASIA

CHINA

SMC (China) Co., Ltd.

HONG KONG

SMC Pneumatics (Hong Kong) Ltd.

INDIA

SMC Pneumatics (India) Pvt. Ltd.

MALAYSIA

SMC Pneumatics (S.E.A.) Sdn. Bhd.

PHILIPPINES

Shoketsu SMC Corporation

SINGAPORE

SMC Pneumatics (S.E.A.) Pte. Ltd.

SOUTH KOREA

SMC Pneumatics Korea Co., Ltd.

TAIWAN

SMC Pneumatics (Taiwan) Co., Ltd.

THAILAND

SMC (Thailand) Ltd.

NORTH AMERICA

CANADA

SMC Pneumatics (Canada) Ltd.

MEXICO

SMC Corporation (Mexico), S.A. de C.V.

U.S.A.

SMC Corporation of America

SOUTH AMERICA

ARGENTINA

SMC Argentina S.A.

BOLIVIA

SMC Pneumatics Bolivia S.r.l.

BRAZIL

SMC Pneumáticos do Brasil Ltda

CHILE

SMC Pneumatics (Chile) S.A.

VENEZUELA

SMC Neumatica Venezuela S.A.

OCEANIA

AUSTRALIA

SMC Pneumatics (Australia) Pty. Ltd.

NEW ZEALAND

SMC Pneumatics (N.Z.) Ltd.



Safety Instructions

Be sure to read "Precautions for Handling Pneumatic Devices" (M-03-E3A) before using.

SMC Corporation

Akihabara UDX 15F,
4-14-1, Sotokanda, Chiyoda-ku, Tokyo 101-0021, JAPAN
Phone: 03-5207-8249 Fax: 03-5298-5362
URL <http://www.smcworld.com>
© 2008 SMC Corporation All Rights Reserved

Specifications are subject to change without prior notice
and any obligation on the part of the manufacturer.

D-DN

1st printing MT printing MT 16400DN Printed in Japan.

This catalog is printed on recycled paper with concern for the global environment.