

Speed Controller with One-touch Fittings In-line Type/Panel Mount Type

AS□□□1F-3 Series



Panel mount thickness:
3.5 mm at the maximum

Easy installation and removal

Installation of hexagon nuts on panel nuts up and down in two locations enables user to mount or remove it depending upon the situation.

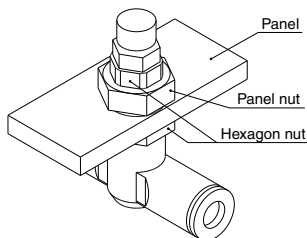

Symbol

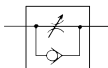

Flow Direction Symbols on Body

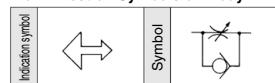

Made to Order
(For details, refer to page 622.)

Symbol	Specifications
-X12	Lubricant: Vaseline
-X21	Grease-free (Seal: Fluorine-coated) + Throttle valve (Without check valve)
-X214	Throttle valve (Without check valve)

Model

Model	Applicable tubing O.D.													
	Metric size						Inch size							
	3.2	4	6	8	10	12	1/8	5/32	3/16	1/4	5/16	3/8	1/2	
AS1001F	●	●					●							
AS2001F		●	●					●	●	●				
AS2051F			●	●					●	●	●			
AS3001F			●	●	●	●			●	●	●	●		
AS4001F						●	●					●	●	

Specifications

Fluid	Air
Proof pressure	1.5 MPa
Max. operating pressure	1 MPa
Min. operating pressure	0.1 MPa
Ambient and fluid temperature	-5 to 60°C (No freezing)
Applicable tubing material ⁽¹⁾	Nylon, Soft nylon, Polyurethane

Note 1) Use caution regarding the max. operating pressure when soft nylon or polyurethane tubing is used. (Refer to pages 464 and 465 for details.)

Note 2) Brass parts are all electroless nickel plated.

Flow Rate and Sonic Conductance

Model	AS1001F	AS2001F	AS2051F	AS3001F	AS4001F						
Tubing O.D.	Metric size	ø3.2, ø4, ø6	ø4, ø6	ø6, ø8	ø6, ø8, ø10, ø12, ø10, ø12						
	Inch size	ø1/8", ø3/32", ø3/16", ø1/4"	ø3/16", ø1/4"	ø3/16", ø5/16"	ø1/4", ø5/16", ø3/8", ø3/8", ø1/2"						
Controlled flow	Flow rate (L/min(ANR))	100	130	230	290	460	420	660	920	1050	1390
Free flow	Sonic conductance (dm ³ /(s·bar))	0.28	0.36	0.64	0.8	1.3	1.2	1.8	2.6	2.9	3.9
Critical pressure ratio	Controlled flow	0.2	0.2		0.2		0.2		0.2		0.2
	Free flow	0.25	0.25		0.25		0.25		0.25		0.25

Note) Flow rate values are measured at 0.5 MPa and 20°C.

How to Order

AS **200** 1 F - **06** - **3** - **□** - **□**

Body size

100	M5 standard
200	1/8 standard
205	1/4 standard
300	3/8 standard
400	1/2 standard

Panel mount type

Lock nut option

NII	Hexagon lock nut
J	Round lock nut

Made to Order
Refer to page 622 for details.

Applicable tubing O.D. (Note)

Metric size	Inch size
23	ø3.2"
04	ø4
06	ø6
08	ø8
10	ø10
12	ø12
01	ø1/8"
03	ø5/32"
05	ø3/16"
07	ø1/4"
09	ø5/16"
11	ø3/8"
13	ø1/2"

With One-touch fittings

Note) For applicable tubing O.D. selection, refer to the Model.
= Use ø1/8" tube.



AS□□□1F-3 Series

Needle Valve/Flow Rate Characteristics

Note) The flow rate characteristics are representative values.

AS1001F

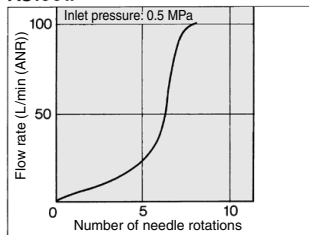

AS2001F

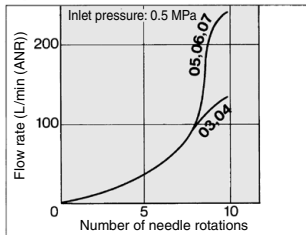

AS2051F

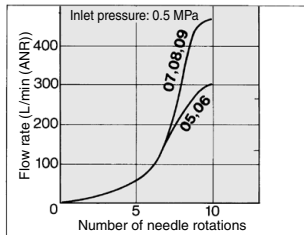

AS3001F

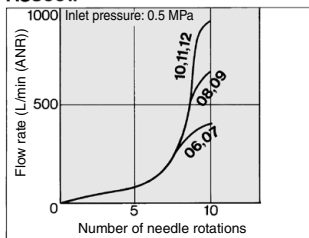

AS4001F

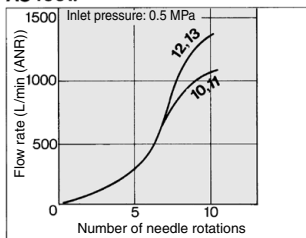

⚠ Caution

Be sure to read this before handling the products.
Refer to back page 50 for Safety Instructions and pages 543 to 546 for Flow Control Equipment Precautions.

Made to Order



Lubricant: Vaseline

X12

Grease-free (Seal: Fluorine Coating) + Throttle Valve (Without Check Valve)

X21

Ex.) AS2001F-04-3-X12

Ex.) AS2001F-04-3-X21

Note) Not particle-free

Throttle Valve (Without Check Valve)

X214

Ex.) AS2001F-04-3-X214

Speed Controller with One-touch Fittings In-line Type/Panel Mount Type **AS□□□1F-3 Series**

Construction

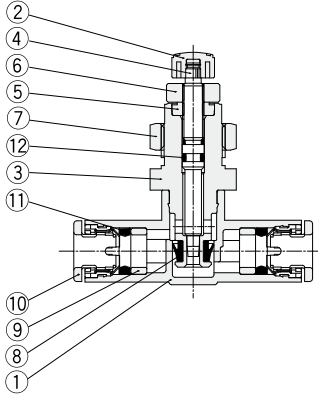

No.	Description	Material	Note
1	Body A	PBT	
2	Handle	PBT	
3	Body B	Brass	Electroless nickel plated
4	Needle	Brass	Electroless nickel plated
5	Needle guide	Brass	Electroless nickel plated
6	Lock nut	Steel ⁽¹⁾	Zinc chromated
7	Panel nut	Brass	Electroless nickel plated
8	U seal	HNBR	
9	Spacer	—	
10	Cassette	—	
11	Packing	NBR	
12	O-ring	NBR	

Note 1) Option: The round lock nut is made of electroless nickel plated brass.

Dimensions

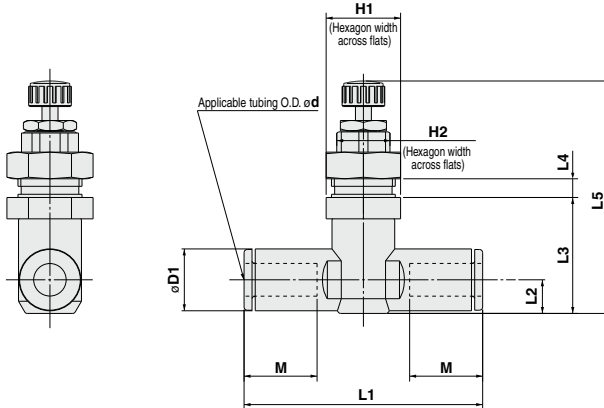

Metric Size

Model	d	D1	H1	H2	L1	L2	L3	L4		L5 ⁽¹⁾		M	Panel-cut dimension	Weight (g)
								Max.	Min.	Max.	Min.			
AS1001F-23-3	3.2	8.4			38	4.5	16.8			37.6	34.4			18
AS1001F-04-3	4	9.3	12	8	39.2	5.2	17.4	3.5		38.2	35	12.7	10.5	19
AS1001F-06-3	6	11.6			40.7	6.2	18.5			39.3	36.1	13.5		20
AS2001F-04-3	4	9.3		14	40.7	5.2	20.7	3.5		48	42.5	12.7	12.5	28
AS2001F-06-3	6	11.6			44.8	6.3	21.8			49.1	43.6	13.5		29
AS2051F-06-3	6	12.8		17	53.2	6.7	25.7	3.5		53.5	48.1	17	15.5	49
AS2051F-08-3	8	15.2			59.8	8.1	27			54.8	49.4	18		54
AS3001F-06-3	6	12.8			59	7.4	31.3			60.1	54.7	17		85
AS3001F-08-3	8	15.2	21	16	64.4	8.2	32.1	3.5		60.9	55.5	18	18.5	88
AS3001F-10-3	10	18.5			71.6	9.8	33.7			62.5	57.1	21		99
AS3001F-12-3	12	20.9			76	11	34.9			63.7	58.3	22		100
AS4001F-10-3	10	18.5			77.7		35	3.5		69.3	61	21	24.5	167
AS4001F-12-3	12	20.9	27	21	82.1	11.3	36			70.3	62	22		171

Note 1) Reference dimensions

Inch Size

Model	d	D1	H1	H2	L1	L2	L3	L4		L5 ⁽¹⁾		M	Panel-cut dimension	Weight (g)
								Max.	Min.	Max.	Min.			
AS1001F-01-3	1/8"	8.4			38	4.5	16.8			37.6	34.4			18
AS1001F-03-3	5/32"	9.3	12	8	39.2	5.2	17.4	3.5		38.2	35	12.7	10.5	19
AS1001F-05-3	3/16"	11.4			48.7	6.2	18.5			39.3	36.1	13.5		24
AS1001F-07-3	1/4"	12			40.7					48	42.5	12.7		21
AS2001F-03-3	5/32"	9.3			40.7	5.2	20.7	3.5		48	42.5	12.7	12.5	28
AS2001F-05-3	3/16"	11.4	14	10	50	6.2	21.6	3.5		48.9	43.4	16.5	12.5	34
AS2001F-07-3	1/4"	13.2			52.2	7.1	22.5			49.8	44.3	17		37
AS2051F-05-3	3/16"	11.4			52.2	6.2	25.2			53	47.6	16.5		47
AS2051F-07-3	1/4"	13.2	17	13	54.4	7.1	26	3.5		53.8	48.4	17	15.5	49
AS2051F-09-3	5/16"	15.2			59.8	8.1	27			54.8	49.4	18		54
AS3001F-07-3	1/4"	13.2			59	7.4	31.3			60.1	54.7	17		84
AS3001F-09-3	5/16"	15.2	21	16	64.4	8.2	32.1	3.5		60.9	55.5	18	18.5	88
AS3001F-11-3	3/8"	17.2			70.8	9.5	33.3			62.1	56.7	21		95
AS4001F-11-3	3/8"	17.9			76.9	10.3	34.9			69.2	60.9	21		175
AS4001F-13-3	1/2"	21.7	27	21	83.1	11.6	36.3	3.5		70.6	62.3	22	24.5	188

Note 1) Reference dimensions

Speed Controller with One-touch Fittings/Centralized Piping Type Made to Order Specifications AS-DPP00092/00093

Please contact SMC for details dimensions, specifications and lead times.

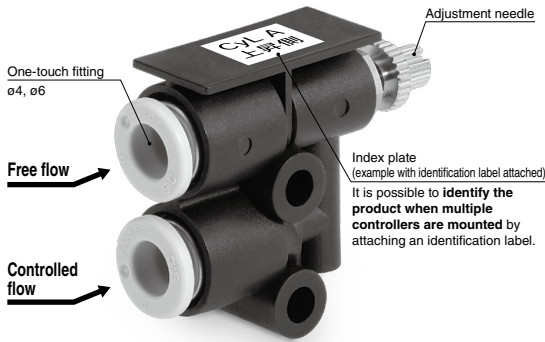

Installation example

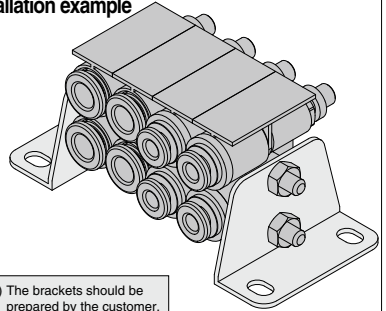

Specifications

Model	AS-DPP00092	AS-DPP00093
Applicable tubing O.D.	ø4	ø6
Fluid	Air	
Proof pressure	1.5 MPa	
Max. operating pressure	1 MPa (0.7 MPa (Note 1))	
Min. operating pressure	0.1 MPa	
Ambient and fluid temperature	-5 to 60°C (No freezing)	
Applicable tubing material (Note 1)	Nylon, Soft nylon, Polyurethane	

Note 1) Use caution at the max. operating pressure when soft nylon or polyurethane tubing is used.
(Refer to pages 464 and 465 for details.)

Note 2) Brass parts are all electroless nickel plated.

Flow Rate Characteristics

AS-DPP00092 AS-DPP00093

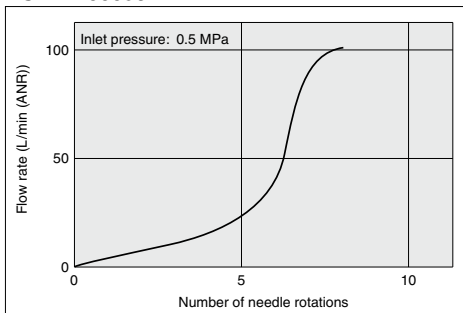

Dimensions

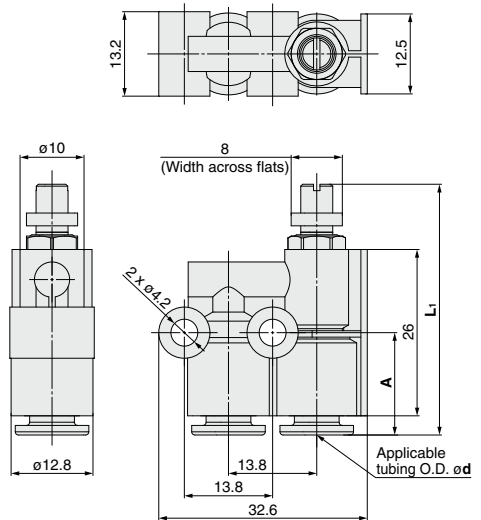

Dimensions

Model	Applicable tubing O.D. d	A	L ₁ (mm)	
			MAX.	MIN.
AS-DPP00092	4	19.4	46.9	42.7
AS-DPP00093	6	16	43.5	39.3