

Single Stage Regulator for Ultra High Purity

Low to intermediate flow

Series AZ1000

- For UHP gas delivery
- High inlet pressure type: Max. 3500 psig (24.1 MPa)
- Flow capacity Standard: to 30 slpm
HF (option): to 120 slpm
- Body material: 316L SS
- Hastelloy internals available for corrosion resistance



How to Order

Port Number

① ② ③ ④

AZ10 01 S 2PW FV4 FV4

Delivery pressure

Code	Delivery pressure
01	1 to 10 psig (0.007 to 0.07 MPa)
02	1 to 30 psig (0.007 to 0.2 MPa)
06	2 to 60 psig (0.014 to 0.4 MPa)
10	2 to 100 psig (0.014 to 0.7 MPa)
15	5 to 150 psig (0.034 to 1.0 MPa)

Material

Code	Body	Poppet	Diaphragm	Nozzle
S	316L SS	316L SS	316L SS	316L SS
SHP	316L SS	Hastelloy® C-22	Hastelloy® C-22	316L SS

Surface finish

Code	Surface finish Ra
No code	10 μin. (0.25 μm) Standard
Q	25 μin. (0.62 μm)

Ports

Code	Ports
2PW	2 ports
3PW	3 ports
4PW	4 ports

Connections (Inlet ①, Outlet ②)

Code	Connections
FV4	1/4 inch face seal (Female)
MV4	1/4 inch face seal (Male)
FV6	3/8 inch face seal (Female)
MV6	3/8 inch face seal (Male)
TW6	3/8 inch tube weld

Gauge port (Inlet ③, Outlet ④)

Code	Pressure gauge *1	
	psig/bar unit	MPa unit
No code	No pressure gauge	
0	No gauge port	
V3	-30 in.Hg to 30 psig -0.1 to 0.2 MPa	
L	-30 in.Hg to 60 psig -0.1 to 0.4 MPa	
1	-30 in.Hg to 100 psig -0.1 to 0.7 MPa	
H	-30 in.Hg to 160 psig -0.1 to 1.1 MPa	
2	0 to 200 psig	0 to 1.4 MPa
4	0 to 400 psig	0 to 3 MPa
10	0 to 1000 psig	0 to 7 MPa
40	0 to 4000 psig	0 to 28 MPa

*1 Refer to gauge guide (P.94) for gauge specifications.

Bonnet option

Code	Bonnet
No code	Standard
P	Panel installation *6)
BP	Bonnet port (NPT 1/8 inch)

*6) Panel mounting hole: dia. 1.56 inch (39.6 mm).

Option

Code	Specification
No code	Standard (Cv: 0.09)
HF	High flow (Cv: 0.15)

Seat material

Code	Material
No code	PCTFE (Standard)
VS	Vespe® *3)
TF	PTFE *4) *5)

*3) Not available with SHP material.
*4) PTFE recommended for applications such as within a process tool.
*5) Source pressure rating is limited to 300 psig (2.1 MPa) or less.

Pressure gauge unit *2)

Code	Unit
No code	psig/bar
MPA	MPa

*2) Pressure gauge unit MPa or psig/bar selectable. However under Japanese regulation, only MPa is available in Japan.

Porting Configuration

① IN ② OUT ③ Gauge port (Inlet) ④ Gauge port (Outlet)

Sample Order Number

Port	①	②	③	④
AZ1001S	2PW	FV4	FV4	
	3PW	FV4	FV4	V3 MPA
	4PW	FV4	FV4	1 V3 MPA

Specifications

Operating Parameters		AZ1001	AZ1002	AZ1006	AZ1010	AZ1015
Delivery pressure		1 to 10 psig (0.007 to 0.07 MPa)	1 to 30 psig (0.007 to 0.2 MPa)	2 to 60 psig (0.014 to 0.4 MPa)	2 to 100 psig (0.014 to 0.7 MPa)	5 to 150 psig (0.034 to 1.0 MPa)
Gas Select compatible materials of construction for the gas						
Source pressure		Vacuum to 300 psig (2.1 MPa)	Vacuum to 3500 psig (24.1 MPa) *1)			
Proof pressure (Inlet)		5000 psig (34.5 MPa)				
Burst pressure		10000 psig (69 MPa)				
Ambient and operating temperature		-40 to 160°C (-40 to 71°C) (No freezing) *2)				
Cv		0.09				
Leak rate	Inboard leakage	2 x 10 ⁻¹¹ Pa·m ³ /sec				
	Outboard leakage	2 x 10 ⁻¹⁰ Pa·m ³ /sec *3)				
Across the seat leak		4 x 10 ⁻⁹ Pa·m ³ /sec *4)				
Surface finish		Ra 10 μin. (0.25 μm) Option: 25 μin. (0.62 μm)				
Connections		Face seal, Tube weld				
Supply pressure effect		0.38 psig (0.0026 MPa) rise in delivery pressure per 100 psig (0.7 MPa) source pressure drop				
Installation		Bottom mount (Option: panel mount)				
Internal volume		0.49 in ³ (8 cm ³)				
Mass		2.76 lbs (1.25 kg) *5)				

*1) Max 300 psig (2.1MPa) for PTFE seat.

*2) 14 to 194°F (-10 to 90°C) for Vespe® seat.

*3) Tested with Helium gas inlet pressure 1500 psig (10.5 MPa).

*4) Tested with Helium gas inlet pressure 1000 psig (7 MPa).

*5) Mass, including individual boxed weight, may vary depending on connections or options.

Single Stage Regulator for Ultra High Purity *Series AZ1000*

Low to intermediate flow

Recommendations

Regulators

AP

SL

AZ

AK

KT

BP

Diaphragm Valves

Check Valves

Vacuum Generators

Flow Switches

Technical Data/
Glossary of Terms

Precautions

Option

High flow

Higher flow capacity with internal changes only, no change in external dimensions. Changes from the standard type are:

Option	Other Parameters	AZ1001	AZ1002	AZ1006	AZ1010	AZ1015
HF	Cv	0.15				
	Supply pressure effect	0.75 psig (0.0052 MPa) rise in delivery pressure per 100 psig (0.7 MPa) source pressure drop				

Wetted Parts Material

Wetted Parts	S	SHP
Body	316L SS	
Surface finish	Electropolish + Passivation	
Poppet	316L SS	Hastelloy® C-22
Diaphragm	316L SS	Hastelloy® C-22
Nozzle	316L SS	
Seat	PCTFE (Option: Vespel®, PTFE)	PCTFE (Option: PTFE)

Dimensions

inch (mm)

AZ1000

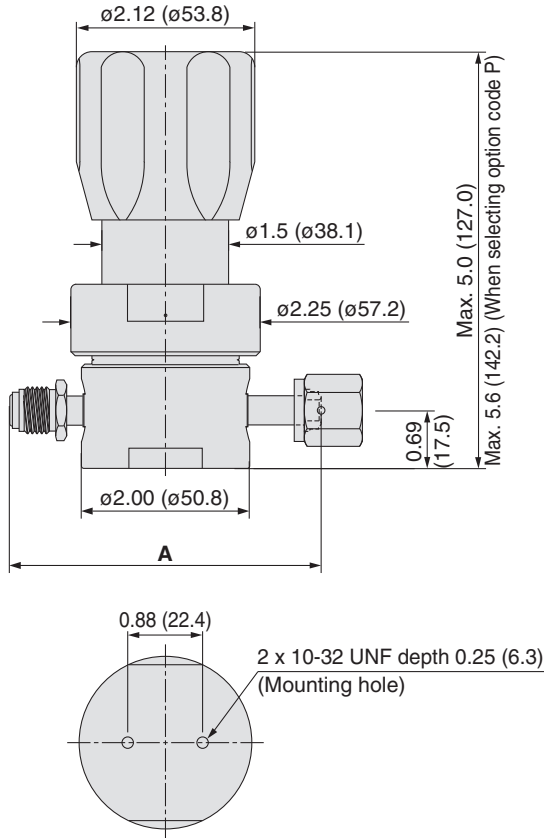

Connections	A	
	inch	(mm)
FV4	3.70	(94.0)
MV4	3.70	(94.0)
FV6	4.70	(119.4)
MV6	4.70	(119.4)
TW6	2.96	(75.2)

Flow Characteristics

AZ1000HF

Inlet pressure: --- 100 psig (0.69 MPa) - - - 50 psig (0.34 MPa)
— 30 psig (0.21 MPa)

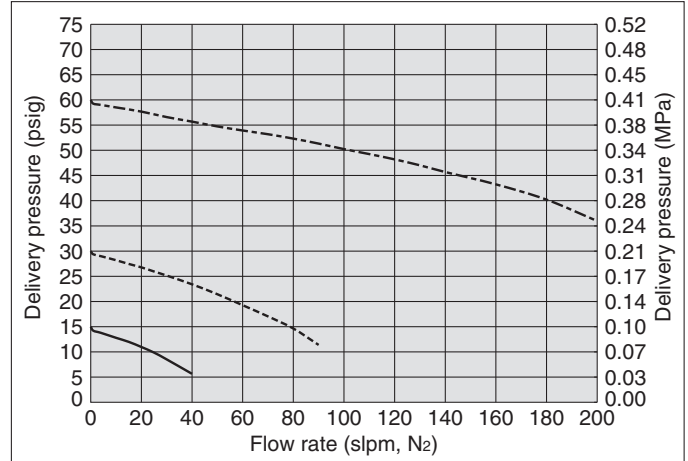

AZ1000

Inlet pressure: 100 psig (0.69 MPa) - - - 80 psig (0.55 MPa)
- - - 40 psig (0.28 MPa) — 20 psig (0.14 MPa)

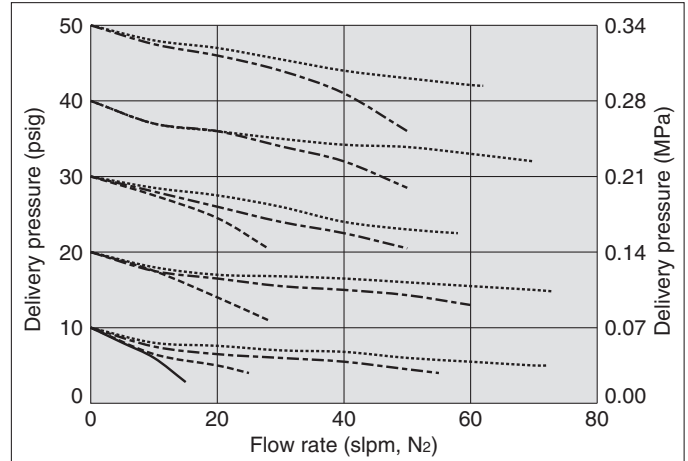

Hastelloy® is a registered trademark of Haynes International.
Vespel® is a registered trademark of DuPont.

Single Stage Regulator for Ultra High Purity

Low flow
(Tied-diaphragm)

Series AZ1500

- For UHP gas delivery
- High inlet pressure type: Max. 3500 psig (24.1 MPa)
- Body material: 316L SS
- Hastelloy internals available for corrosion resistance
- Tied-diaphragm design



How to Order

Port Number
① ② ③ ④

AZ15 02 S 2PW FV4 FV4

Delivery pressure

Code	Delivery pressure
02	1 to 30 psig (0.007 to 0.2 MPa)
06	2 to 60 psig (0.014 to 0.4 MPa)
10	2 to 100 psig (0.014 to 0.7 MPa)
15	5 to 150 psig (0.034 to 1.0 MPa)

Material

Code	Body	Poppet	Diaphragm	Nozzle
S		316L SS	316L SS	
SHP	316L SS	Hastelloy® C-22	Hastelloy® C-22	316L SS

Surface finish

Code	Surface finish Ra
No code	10 μin. (0.25 μm) Standard
Q	25 μin. (0.62 μm)

Ports

Code	Ports
2PW	2 ports
3PW	3 ports
4PW	4 ports

Connections (Inlet ①, Outlet ②)

Code	Connections
FV4	1/4 inch face seal (Female)
MV4	1/4 inch face seal (Male)
FV6	3/8 inch face seal (Female)
MV6	3/8 inch face seal (Male)
TW6	3/8 inch tube weld

Gauge port (Inlet ③, Outlet ④)

Code	Pressure gauge *1)	
	psig/bar unit	MPa unit
No code	No gauge port	
0	No pressure gauge (Connections: 1/4 inch face seal male)	
V3	-30 in.Hg to 30 psig	-0.1 to 0.2 MPa
L	-30 in.Hg to 60 psig	-0.1 to 0.4 MPa
1	-30 in.Hg to 100 psig	-0.1 to 0.7 MPa
H	-30 in.Hg to 160 psig	-0.1 to 1.1 MPa
2	0 to 200 psig	0 to 1.4 MPa
4	0 to 400 psig	0 to 3 MPa
10	0 to 1000 psig	0 to 7 MPa
40	0 to 4000 psig	0 to 28 MPa

Bonnet option

Code	Bonnet
No code	Standard
P	Panel installation *4)
BP	Bonnet port (NPT 1/8 inch)

*4) Panel mounting hole: dia. 1.56 inch (39.6 mm).

Seat material

Code	Material
No code	PCTFE(Standard)
VS	Vespe® *3)

*3) Not available with SHP material.

Pressure gauge unit *2)

Code	Unit
No code	psig/bar
MPA	MPa

*2) Pressure gauge unit MPa or psig/bar selectable. However under Japanese regulation, only MPa is available in Japan.

Porting Configuration

Sample Order Number

Port	①	②	③	④
AZ1510S	2PW/FV4	FV4		
	3PW/FV4	FV4	0	
	3PW/FV4	FV4	1	MPa
	4PW/FV4	FV4	40	1 MPa

① IN ② OUT ③ Gauge port (Inlet) ④ Gauge port (Outlet)

*1) Refer to gauge guide (P.94) for gauge specifications.

Specifications

Operating Parameters		AZ1502	AZ1506	AZ1510	AZ1515
Delivery pressure		1 to 30 psig (0.007 to 0.2 MPa)	2 to 60 psig (0.014 to 0.4 MPa)	2 to 100 psig (0.014 to 0.7 MPa)	5 to 150 psig (0.034 to 1.0 MPa)
Gas					
Select compatible materials of construction for the gas					
Source pressure		Vacuum to 3500 psig (24.1 MPa)			
Proof pressure (Inlet)		5000 psig (34.5 MPa)			
Burst pressure		10000 psig (69 MPa)			
Ambient and operating temperature		-40 to 160°C (-40 to 71°C) (No freezing) *1)			
Cv		0.09			
Leak rate	Inboard leakage	2 x 10 ⁻¹¹ Pa·m ³ /sec			
	Outboard leakage	2 x 10 ⁻¹⁰ Pa·m ³ /sec *2)			
Across the seat leak		4 x 10 ⁻⁹ Pa·m ³ /sec *3)			
Surface finish		Ra 10 μin.(0.25 μm) Option: 25 μin.(0.62 μm)			
Connections		Face seal, Tube weld			
Supply pressure effect		0.41 psig (0.0028 MPa) rise in delivery pressure per 100 psig (0.7 MPa) source pressure drop			
Installation		Bottom mount (Option: panel mount)			
Internal volume		0.51 in ³ (8.4 cm ³)			
Mass		2.8 lbs (1.27 kg) *4)			

*1) 14 to 194°F (-10 to 90°C) for Vespe® seat.

*2) Tested with Helium gas inlet pressure 1500 psig (10.5 MPa).

*3) Tested with Helium gas inlet pressure 1000 psig (7 MPa).

*4) Mass, including individual boxed weight, may vary depending on connections or options.

Single Stage Regulator for Ultra High Purity Series AZ1500

Low flow (Tied-diaphragm)

Wetted Parts Material

Wetted Parts	S	SHP
Body	316L SS	
Surface finish	Electropolish + Passivation	
Poppet	316L SS	Hastelloy® C-22
Diaphragm	316L SS	Hastelloy® C-22
Nozzle	316L SS	
Seat	PCTFE (Option: Vespel®)	PCTFE

Dimensions

inch (mm)

AZ1500

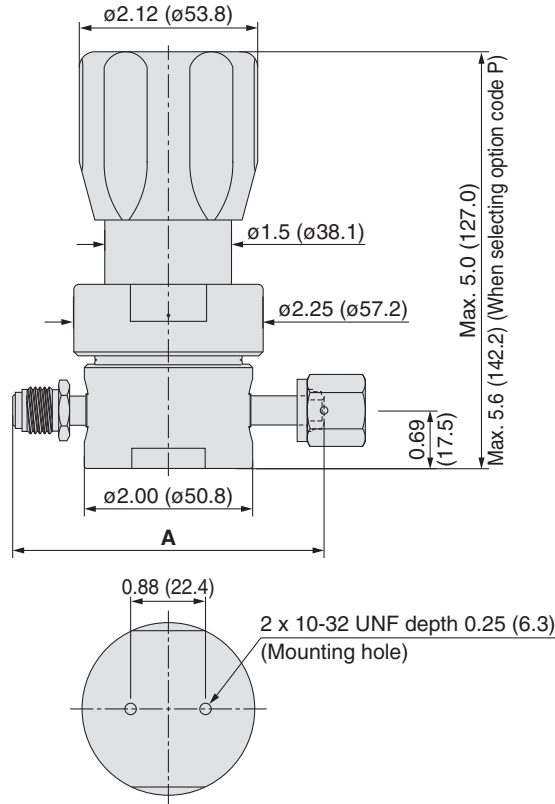

Connections	A	
	inch	(mm)
FV4	3.70	(94.0)
MV4		
FV6	4.70	(119.4)
MV6		
TW6	2.96	(75.2)

Flow Characteristics

AZ1500 Inlet pressure: 2000 to 3000 psig (13.8 to 20.7 MPa) --- 1000 psig (6.9 MPa)
 ----- 500 psig (3.4 MPa) ——— 200 psig (1.4 MPa)

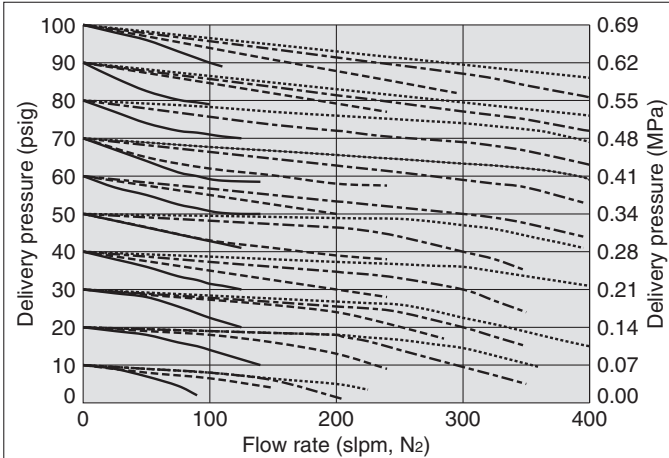

AZ1500 Inlet pressure: 100 psig (0.69 MPa) --- 80 psig (0.55 MPa)
 ----- 40 psig (0.28 MPa) ——— 20 psig (0.14 MPa)

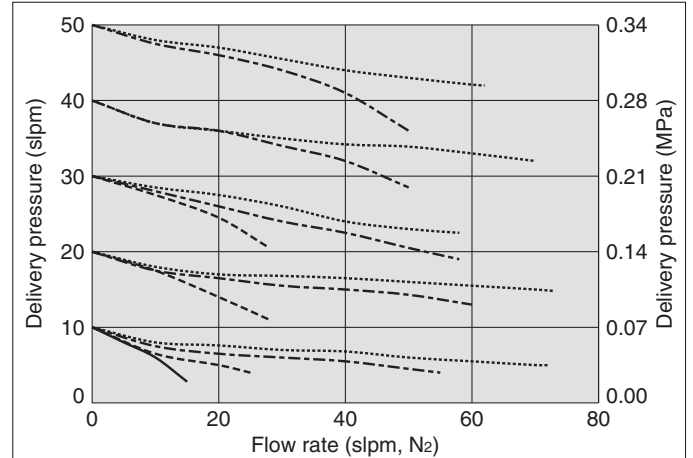

Hastelloy® is a registered trademark of Haynes International.
 Vespel® is a registered trademark of DuPont.

Single Stage Regulator for Ultra High Purity

Intermediate flow (Tied-diaphragm)

Series AZ1400T

- For UHP gas delivery
- High inlet pressure type Standard: Max. 2300 psig (15.9 MPa)
HR (option): Max. 3000 psig (20.7 MPa)
- Flow capacity to 400 slpm
- Body material: 316L SS
- Hastelloy internals standard
- Sub-atmospheric pressure delivery option
- Tied-diaphragm design



How to Order

Port Number
① ② ③ ④

AZ14 02 T S **2PW FV4 FV4**

Delivery pressure

Code	Delivery pressure
02	1 to 30 psig (0.007 to 0.2 MPa) Sub-atmospheric (A): 100 mm Hg absolute to 30 psig (-88kPa to 0.2 MPa)
06	2 to 60 psig (0.014 to 0.4 MPa)
10	2 to 100 psig (0.014 to 0.7 MPa)
15	5 to 150 psig (0.034 to 1.0 MPa)

Material

Code	Body	Poppet	Diaphragm
S	316L SS	Hastelloy® C-22	Hastelloy® C-22

Surface finish

Code	Surface finish Ra
No code	10 μin. (0.25 μm) Standard
Q	25 μin. (0.62 μm)

Range options *1)

Code	Specification
No code	Standard
A	Sub-atmospheric

*1) Only available with AZ1402T.

Connections (Inlet ①, Outlet ②)

Code	Connections
FV4	1/4 inch face seal (Female)
MV4	1/4 inch face seal (Male)
FV6	3/8 inch face seal (Female)
MV6	3/8 inch face seal (Male)
TW6	3/8 inch tube weld
FV8	1/2 inch face seal (Female)
MV8	1/2 inch face seal (Male)
TW8	1/2 inch tube weld

Gauge port (Inlet ③, Outlet ④)

Code	Pressure gauge *2)	
	psig/bar unit	MPa unit
No code	No gauge port	
0	No pressure gauge (Connections: 1/4 inch face seal male)	
V3	-30 in.Hg to 30 psig	-0.1 to 0.2 MPa
L	-30 in.Hg to 60 psig	-0.1 to 0.4 MPa
1	-30 in.Hg to 100 psig	-0.1 to 0.7 MPa
H	-30 in.Hg to 160 psig	-0.1 to 1.1 MPa
2	0 to 200 psig	0 to 1.4 MPa
4	0 to 400 psig	0 to 3 MPa
10	0 to 1000 psig	0 to 7 MPa
40	0 to 4000 psig	0 to 28 MPa

*2) Refer to gauge guide (P.94) for gauge specifications.

Bonnet option

Code	Bonnet
No code	Standard
P	Panel installation*5)
BP	Bonnet port (1/8inch)

*5) Panel mounting hole: dia. 1.56 inch (39.6 mm).

Option

Code	Specification
No code	Standard
HR	High inlet pressure (Max. inlet pressure 3000 psig (20.7 MPa)) *4)

*4) Not available with AZ1402T and AZ1406T.

Seat material

Code	Material
No code	PCTFE (Standard)
VS	VespeI®

Pressure gauge unit *3)

Code	Unit
No code	psig/bar
MPA	MPa

*3) Pressure gauge unit MPa or psig/bar selectable. However under Japanese regulation, only MPa is available in Japan.

Porting Configuration

Ports

Code	Ports
2PW	2 ports
3PW	3 ports
4PW	4 ports

① IN
② OUT
③ Gauge port (Inlet)
④ Gauge port (Outlet)

Sample Order Number

	Port ①	Port ②	Port ③	Port ④
AZ1402TS	2PW	FV4	FV4	
	3PW	FV4	FV4	0
	3PW	FV4	FV4	1 MPa
	4PW	FV4	FV4	40 1 MPa

Specifications

Operating Parameters	AZ1402T□□A	AZ1402T	AZ1406T	AZ1410T	AZ1415T
Delivery pressure	100 mm Hg absolute to 30 psig (-88 kPa to 0.2 MPa)	1 to 30 psig (0.007 to 0.2 MPa)	2 to 60 psig (0.014 to 0.4 MPa)	2 to 100 psig (0.014 to 0.7 MPa)	5 to 150 psig (0.034 to 1.0 MPa) (Source pressure 1000psig or less) *1)
Gas	Select compatible materials of construction for the gas				
Source pressure	Vacuum to 300 psig (2.1 MPa)	Vacuum to 2300 psig (15.9 MPa)			
Proof pressure (Inlet)	4000 psig (27.6 MPa)				
Burst pressure	8000 psig (55.2 MPa)				
Ambient and operating temperature	-40 to 160°F (-40 to 71°C) (No freezing) *2)				
Cv	0.45				
Leak rate	Inboard leakage	2 x 10 ⁻¹¹ Pa·m ³ /sec			
	Outboard leakage	2 x 10 ⁻¹⁰ Pa·m ³ /sec *3)			
Across the seat leak	4 x 10 ⁻⁹ Pa·m ³ /sec *4)				
Surface finish	Ra 10 μin. (0.25 μm) Option: 25 μin. (0.62 μm)				
Connection	Face seal, Tube weld				
Supply pressure effect	1.6 psig (0.011 MPa) rise in delivery pressure per 100 psig (0.7 MPa) source pressure drop				
Installation	Bottom mount (Option: panel mount)				
Internal volume	1.06 in ³ (17.4 cm ³)				
Mass	4.5 lbs (2.04 kg) *5)				

*1) Source pressure above 1000 psig (6.9 MPa) decreases maximum delivery pressure to less than 150 psig (1 MPa) due to supply pressure effect. When the source pressure is 2300 psig (15.9 MPa), achievable delivery pressure is around 129 psig (0.89 MPa).

*2) 14 to 194°F (-10 to 90°C) for VespeI® seat.

*3) Tested with Helium gas inlet pressure 1500 psig (10.5 MPa).

*4) Tested with Helium gas inlet pressure 1000 psig (7 MPa).

*5) Mass, including individual boxed weight, may vary depending on connections or options.

Single Stage Regulator for Ultra High Purity Series AZ1400T

Intermediate flow (Tied-diaphragm)

Option

High inlet pressure

Changes from the standard type are:

Option	Other Parameters	AZ1410T	AZ1415T
HR	Source pressure	Vacuum to 3000 psig (20.7 MPa)	
	Proof pressure (Inlet)	4500 psig (31 MPa)	
	Burst pressure	9000 psig (62 MPa)	

Wetted Parts Material

Wetted Parts	S
Body	316L SS
Surface finish	Electropolish + Passivation
Poppet	Hastelloy® C-22
Diaphragm	Hastelloy® C-22
Nozzle	316L SS
Seat	PCTFE (Option: Vespel®)

Dimensions

inch (mm)

AZ1400T

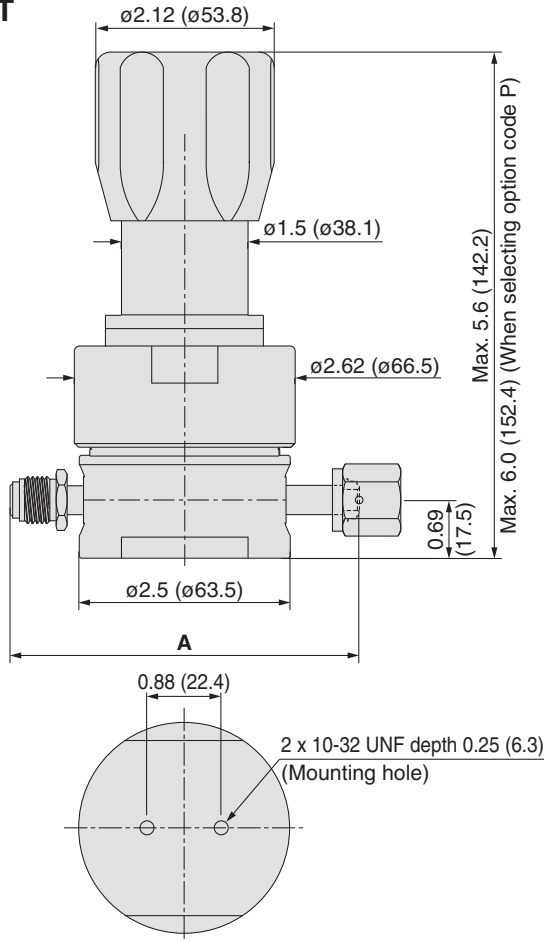

Connections	A	
	inch	(mm)
FV4	4.30	(109.2)
MV4		
FV6	5.22	(132.6)
MV6		
TW6	4.00	(101.6)
FV8	5.22	(132.6)
MV8		
TW8	4.34	(110.2)

Flow Characteristics

AZ1400T Inlet pressure: ---- 80 psig (0.55 MPa) — 60 psig (0.41 MPa)

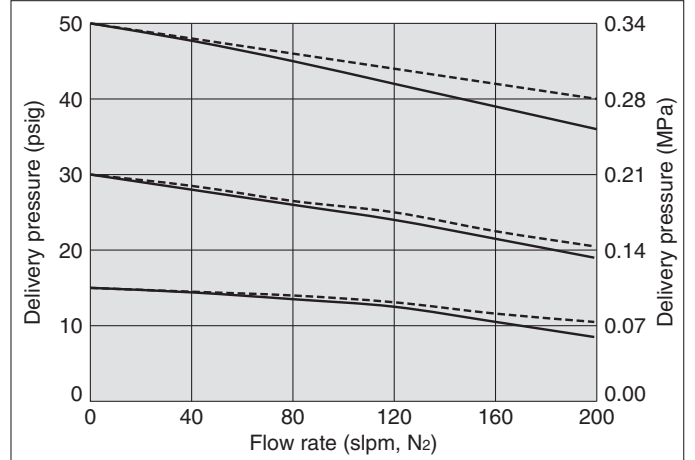

AZ1400T Inlet pressure: --- 2000 psig (13.8 MPa) ---- 600 psig (4.1 MPa) — 200 psig (1.4 MPa)

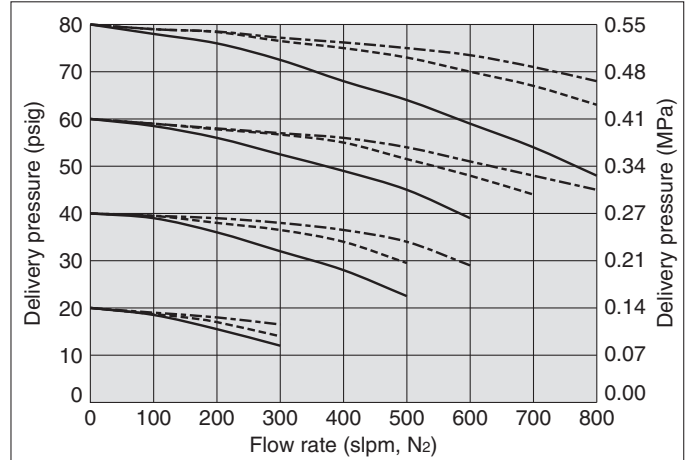

AZ1402TA

Inlet pressure: 2 psig (14 kPa)

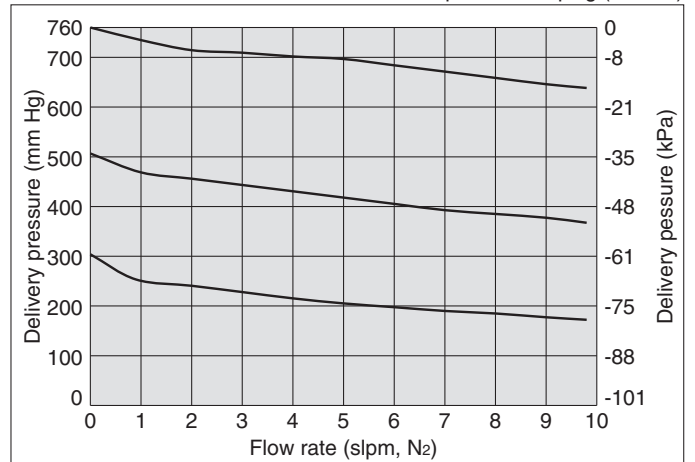

Hastelloy® is a registered trademark of Haynes International.
Vespel® is a registered trademark of DuPont.



Single Stage Regulator for Ultra High Purity High flow

Series AZ1300



- For UHP gas delivery
- Flow capacity to 1000 slpm
- Body material: 316L SS
- Inlet pressure: Max. 300 psig (2.1 MPa)

How to Order

Port Number
① ② ③ ④

AZ13 02 S 2PW FV8 FV8

Delivery pressure

Code	Delivery pressure
02	1 to 30 psig (0.007 to 0.2 MPa)
06	2 to 60 psig (0.014 to 0.4 MPa)
10	2 to 100 psig (0.014 to 0.7 MPa)
15	5 to 150 psig (0.034 to 1.0 MPa)

Material

Code	Body	Poppet	Diaphragm
S	316L SS	316L SS	Hastelloy® C-22

Surface finish

Code	Surface finish Ra
No code	10 μin. (0.25 μm) Standard
Q	25 μin. (0.62 μm)

Connections (Inlet ①, Outlet ②)

Code	Connections
FV4	1/4 inch face seal (Female)
MV4	1/4 inch face seal (Male)
FV6	3/8 inch face seal (Female)
MV6	3/8 inch face seal (Male)
TW6	3/8 inch tube weld
FV8	1/2 inch face seal (Female)
MV8	1/2 inch face seal (Male)
TW8	1/2 inch tube weld

Ports

Code	Ports
2PW	2 ports
3PW	3 ports
4PW	4 ports

Gauge port (Inlet ③, Outlet ④)

Code	Pressure gauge *1)	
	psig/bar unit	MPa unit
No code	No gauge port	
0	No pressure gauge (Connections: 1/4 inch face seal male)	
V3	-30 in.Hg to 30 psig	-0.1 to 0.2 MPa
L	-30 in.Hg to 60 psig	-0.1 to 0.4 MPa
1	-30 in.Hg to 100 psig	-0.1 to 0.7 MPa
H	-30 in.Hg to 160 psig	-0.1 to 1.1 MPa
2	0 to 200 psig	0 to 1.4 MPa
4	0 to 400 psig	0 to 3 MPa

*1) Refer to gauge guide (P.94) for gauge specifications.

Bonnet option

Code	Bonnet
No code	Standard
P	Panel installation*4)
BP	Bonnet port (NPT 1/8 inch)

*4) Panel mounting hole: dia. 1.56 inch (39.6 mm).

Seat material

Code	Material
No code	PCTFE (Standard)
TF	PTFE *3)

*3) PTFE recommended for applications such as within a process tool.

Pressure gauge unit *2)

Code	Unit
No code	psig/bar
MPA	MPa

*2) Pressure gauge unit MPa or psig/bar selectable. However under Japanese regulation, only MPa is available in Japan.

Porting Configuration

① IN ② OUT ③ Gauge port (Inlet)
④ Gauge port (Outlet)

Sample Order Number

	Port ①	Port ②	Port ③	Port ④
AZ1302S	2PW/FV8	FV8		
	3PW/FV8	FV8	0	
	3PW/FV8	FV8	V3	MPA
	4PW/FV8	FV8	H	V3 MPA

Specifications

Operating Parameters	AZ1302	AZ1306	AZ1310	AZ1315
Delivery pressure	1 to 30 psig (0.007 to 0.2 MPa)	2 to 60 psig (0.014 to 0.4 MPa)	2 to 100 psig (0.014 to 0.7 MPa)	5 to 150 psig (0.034 to 1.0 MPa)
Gas	Select compatible materials of construction for the gas			
Source pressure	Vacuum to 300 psig (2.1 MPa)			
Proof pressure (Inlet)	450 psig (3.1 MPa)			
Burst pressure	1200 psig (8.3 MPa)			
Ambient and operating temperature	-40 to 160°F (-40 to 71°C) (No freezing)			
Cv	1.1			
Leak rate	Inboard leakage	2 x 10 ⁻¹¹ Pa·m ³ /sec		
	Outboard leakage	1 x 10 ⁻¹⁰ Pa·m ³ /sec *1)		
Across the seat leak	4 x 10 ⁻⁹ Pa·m ³ /sec			
Surface finish	Ra 10 μin. (0.25 μm) Option: 25 μin. (0.62 μm)			
Connections	Face seal, Tube weld			
Supply pressure effect	4.6 psig (0.031 MPa) rise in delivery pressure per 100 psig (0.7 MPa) source pressure drop			
Installation	Bottom mount (Option: panel mount)			
Internal volume	1.19 in ³ (19.6 cm ³)			
Mass	4.4 lbs (2.0 kg) *2)			

*1) Tested with Helium gas inlet pressure 300 psig (2.1 MPa).

*2) Mass, including individual boxed weight, may vary depending on connections or options.

Single Stage Regulator for Ultra High Purity

High flow **Series AZ1300**

Wetted Parts Material

Wetted Parts	S
Body	316L SS
Surface finish	Electropolish + Passivation
Nozzle	316L SS
Poppet	316L SS
Diaphragm	Hastelloy® C-22
Seat	PCTFE (Option: PTFE)

Dimensions

inch (mm)

AZ1300

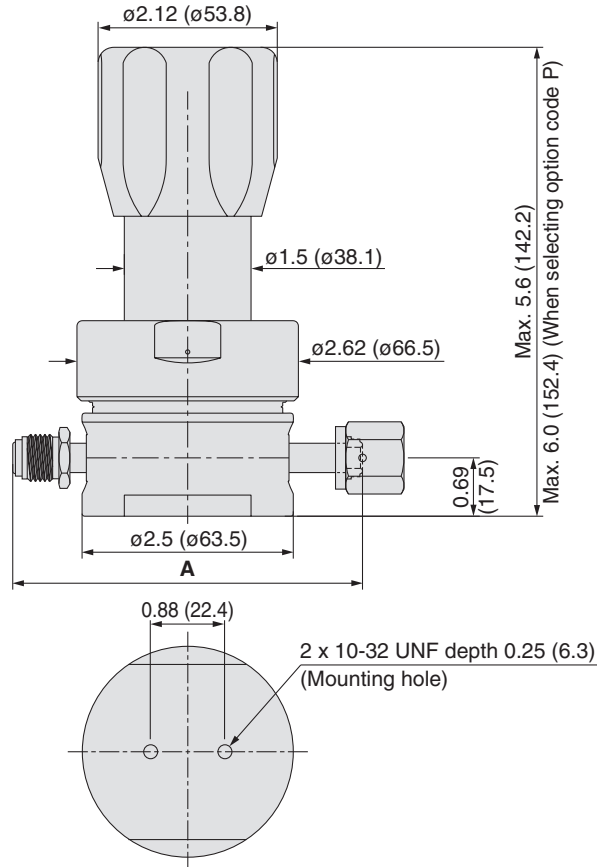

Connections	A	
	inch	(mm)
FV4	4.30	(109.2)
MV4		
FV6	5.22	(132.6)
MV6		
TW6	4.00	(101.6)
FV8	5.22	(132.6)
MV8		
TW8	4.34	(110.2)

Flow Characteristics

AZ1300

Inlet pressure: --- 150 psig (1.0 MPa) --- 100 psig (0.69 MPa)
 — 75 psig (0.52 MPa)

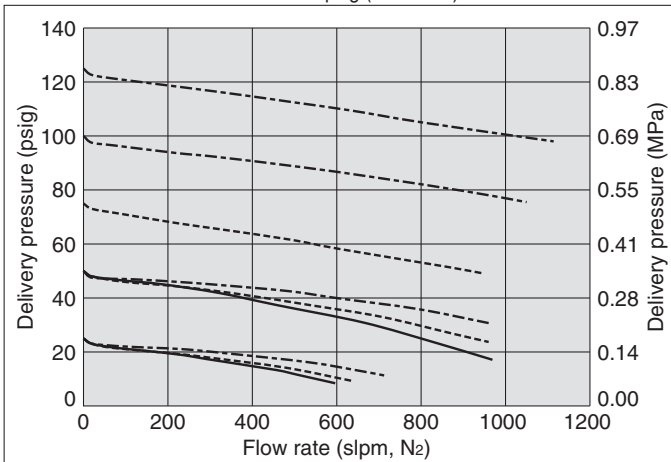

AZ1300

Inlet pressure: --- 75 psig (0.52 MPa) --- 50 psig (0.34 MPa)
 — 25 MPa (0.17MPa)

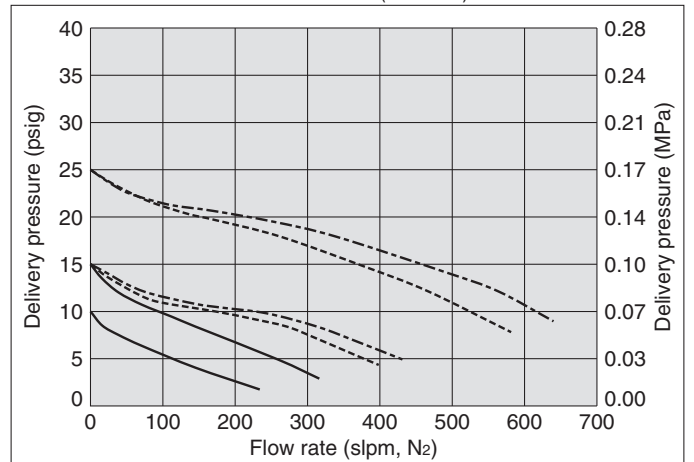

Single Stage Regulator for Ultra High Purity

High flow (Tied-diaphragm)

Series AZ1200

- For UHP gas delivery
- High inlet pressure type Standard: Max. 1700 psig (11.7 MPa)
HR (option): Max. 3000 psig (20.7 MPa)
- Flow capacity Standard to 800 slpm
HF (option): to 1000 slpm
FC (option): to 1500 slpm

- Body material: 316L SS
- Hastelloy internals available for corrosion resistance



How to Order

Port Number
① ② ③ ④

AZ12 02 S 2PW FV8 FV8

Delivery pressure

Code	Delivery pressure
02	1 to 30 psig (0.007 to 0.2 MPa)
06	2 to 60 psig (0.014 to 0.4 MPa)
10	2 to 100 psig (0.014 to 0.7 MPa)
15	5 to 150 psig (0.034 to 1.0 MPa)
25	Preset to 250 psig (1.7 MPa (Preset))

Material

Code	Body	Poppet	Diaphragm
S	316L SS	316L SS	Hastelloy®
SHP		Hastelloy® C-22	C-22

Surface finish

Code	Surface finish Ra
No code	10 μin. (0.25 μm) Standard
Q	25 μin. (0.62 μm)

Ports

Code	Ports
2PW	2 ports
3PW	3 ports
4PW	4 ports

Connections (Inlet ①, Outlet ②)

Code	Connections
FV4	1/4 inch face seal (Female)
MV4	1/4 inch face seal (Male)
FV6	3/8 inch face seal (Female)
MV6	3/8 inch face seal (Male)
TW6	3/8 inch tube weld
FV8	1/2 inch face seal (Female)
MV8	1/2 inch face seal (Male)
TW8	1/2 inch tube weld

Gauge port (Inlet ③, Outlet ④)

Code	Pressure gauge *1)	
	psig/bar unit	MPa unit
No code	No gauge port	
0	No pressure gauge (Connections: 1/4 inch face seal male)	
V3	-30 in.Hg to 30 psig	-0.1 to 0.2 MPa
L	-30 in.Hg to 60 psig	-0.1 to 0.4 MPa
1	-30 in.Hg to 100 psig	-0.1 to 0.7 MPa
H	-30 in.Hg to 160 psig	-0.1 to 1.1 MPa
2	0 to 200 psig	0 to 1.4 MPa
4	0 to 400 psig	0 to 3 MPa
10	0 to 1000 psig	0 to 7 MPa
40	0 to 4000 psig	0 to 28 MPa

*1) Refer to gauge guide (P.94) for gauge specifications.

Bonnet option

Code	Bonnet
No code	Standard
P	Panel installation*6)
BP	Bonnet port (NPT 1/8 inch)

*6) Panel mounting hole: dia. 1.56 inch (39.6 mm).

Option

Code	Specification
No code	Standard (Cv: 0.65)
HF	High flow (Cv: 1.1)
FC	Force compensation (Cv: 0.65) *4)*5)
HR	High inlet pressure (Max. inlet pressure 3000 psig (20.7 MPa)) *4)

*4) FC and HR options are not available with AZ1202, AZ1206 and AZ1225.
*5) FC option is available with 1/2 inch tube seal or 1/2 inch tube weld.

Seat material

Code	Material
No code	PCTFE (Standard)
VS	Vespel® *3)

*3) Not available with SHP material.

Pressure gauge unit *2)

Code	Unit
No code	psig/bar
MPA	MPa

*2) Pressure gauge unit MPa or psig/bar selectable. However under Japanese regulation, only MPa is available in Japan.

Porting Configuration

2PW

3PW

4PW

① IN ② OUT ③ Gauge port (Inlet)
④ Gauge port (Outlet)

Sample Order Number

	Port ①	Port ②	Port ③	Port ④
AZ1210S	2PW	FV8	FV8	
	3PW	FV8	FV8	0
	3PW	FV8	FV8	1 MPA
	4PW	FV8	FV8	40 1 MPA

Specifications

Operating Parameters		AZ1202	AZ1206	AZ1210	AZ1215	AZ1225
Delivery pressure		1 to 30 psig (0.007 to 0.2 MPa)	2 to 60 psig (0.014 to 0.4 MPa)	2 to 100 psig (0.014 to 0.7 MPa)	5 to 150 psig (0.034 to 1.0 MPa)	Preset to 250 psig (1.7 MPa) *2)
Gas Select compatible materials of construction for the gas						
Source pressure Vacuum to 1700 psig (11.7 MPa)						
Proof pressure (Inlet)		2550 psig (17.6 MPa)				
Burst pressure		8000 psig (55.2 MPa)				
Ambient and operating temperature -40 to 160°F (-40 to 71°C) (No freezing) *3)						
Cv 0.65						
Leak rate	Inboard leakage	2 x 10 ⁻¹¹ Pa·m ³ /sec				
	Outboard leakage	2 x 10 ⁻¹⁰ Pa·m ³ /sec *4)				
Across the seat leak		4 x 10 ⁻⁹ Pa·m ³ /sec *5)				
Surface finish		Ra 10 μin.(0.25 μm) Option: 25 μin.(0.62 μm)				
Connections Face seal, Tube weld						
Supply pressure effect 3.5 psig (0.024 MPa) rise in delivery pressure per 100 psig (0.7 MPa) source pressure drop						
Installation Bottom mount (Option: panel mount)						
Internal volume 1.07 in ³ (17.6 cm ³)						
Mass 4.4 lbs (2.0 kg) *6)						

- *1) Source pressure above 1000 psig (6.9 MPa) decreases maximum delivery pressure to less than 150 psig (1 MPa) due to supply pressure effect. When the source pressure is 1700 psig (11.7 MPa), achievable delivery pressure is around 125 psig (0.86 MPa) (HF and FC option 120 psig (0.83 MPa)).
- *2) 250 psig outlet pressure preset at 800 psig (5.5MPa) inlet pressure. Custom inlet/outlet pressure settings available. Please contact SMC.
- *3) 14 to 194°F (-10 to 90°C) for Vespel® seat.
- *4) Tested with Helium gas inlet pressure 1500 psig (10.5 MPa).
- *5) Tested with Helium gas inlet pressure 1000 psig (7 MPa).
- *6) Mass, including individual boxed weight, may vary depending on connections or options.

Single Stage Regulator for Ultra High Purity **Series AZ1200**

High flow (Tied-diaphragm)

Options

1. High flow

Higher flow capacity with internal changes only, no change in external dimensions. Changes from the standard type are:

Option	Other Parameters	AZ1202	AZ1206	AZ1210	AZ1215	AZ1225
HF	Cv	1.1				
	Supply pressure effect	4.2 psig (0.029 MPa) rise in delivery pressure per 100 psig (0.7 MPa) source pressure drop				

2. Force compensation

Force compensation feature added to HF option and has wider flow capacity than HF option.

Changes from the standard type are:

Option	Other Parameters	AZ1210	AZ1215
FC	Source pressure	Vacuum to 300 psig (2.1 MPa)	
	Cv	0.65	
	Supply pressure effect	4.2 psig (0.029 MPa) rise in delivery pressure per 100 psig (0.7 MPa) source pressure drop	
	Connections	1/2 inch face seal 1/2 inch tube weld	

3. High inlet pressure

Changes from the standard type are:

Option	Other Parameters	AZ1210	AZ1215
HR	Source pressure	Vacuum to 3000 psig (20.7 MPa)	
	Proof pressure (Inlet)	4500 psig (31 MPa)	
	Burst pressure	9000 psig (62 MPa)	

Dimensions

inch (mm)

AZ1200

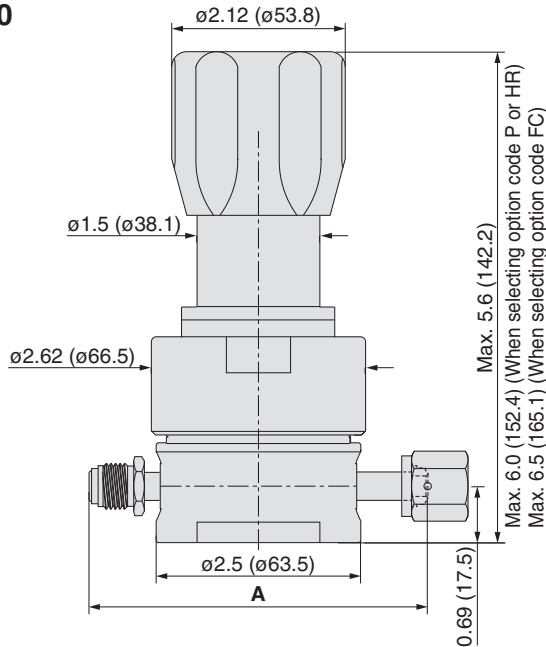

Connections	A	
	inch	(mm)
FV4	4.30	(109.2)
MV4	4.30	(109.2)
FV6	5.22	(132.6)
MV6	5.22	(132.6)
TW6	4.00	(101.6)
FV8	5.22	(132.6)
MV8	5.22	(132.6)
TW8	4.34	(110.2)

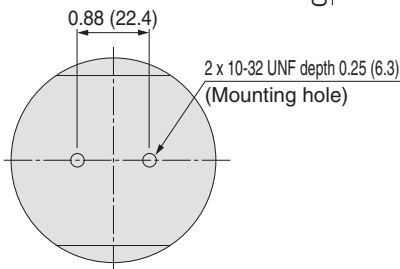

Hastelloy® is a registered trademark of Haynes International.
VespeI® is a registered trademark of DuPont.

Wetted Parts Material

Wetted Parts	S	SH
Body	316L SS	
Surface finish	Electropolish + Passivation	
Poppet	316L SS	Hastelloy® C-22
Diaphragm	Hastelloy® C-22	
Nozzle	316L SS	
Seat	PCTFE (Option: VespeI®)	PCTFE

Flow Characteristics

AZ1200 Inlet pressure: ---- 80 psig (0.55 MPa) — 60 psig (0.41 MPa)
1/2 inch connections *

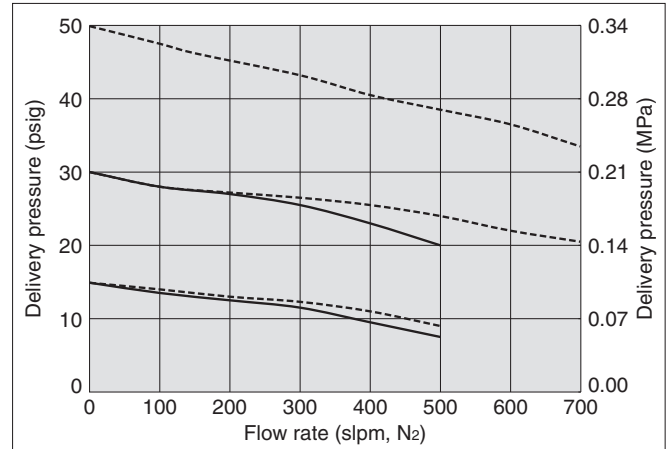

AZ1200HF

Inlet pressure: --- 150 psig (1.0 MPa) ---- 100 psig (0.69 MPa)
50 psig (0.34 MPa)

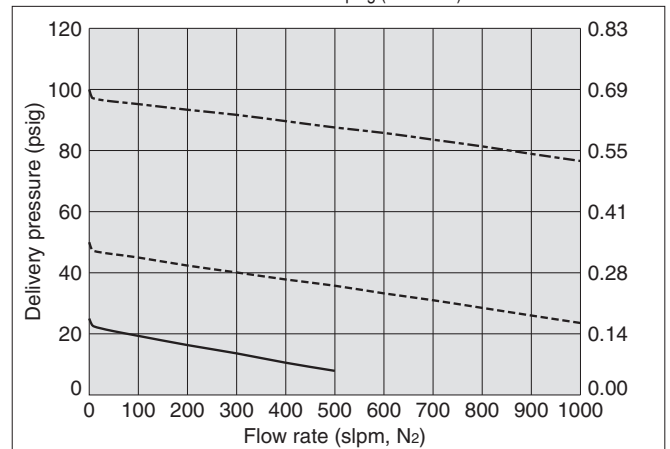

AZ1200FC

Inlet pressure: 150 psig (1.0 MPa)
3/4 inch connections *

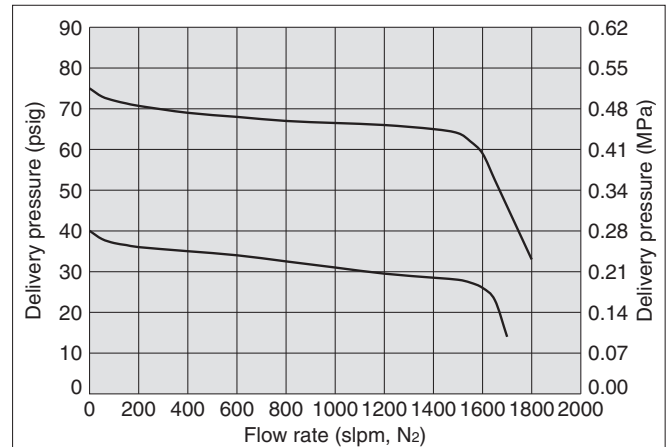

* If connection size differs, flow characteristics also differ.

Single Stage Regulator for Ultra High Purity

High flow (Tied-diaphragm)

Series AZ9200

- For UHP gas delivery
- Inlet pressure : Max. 300 psig (2.1 MPa)
- Flow capacity to 2000 slpm
- Body material: 316L SS

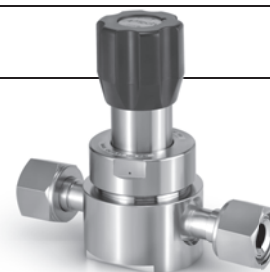

How to Order

①
②
③

AZ92 **02** **S** **2PW** **FV12** **FV12**

Delivery pressure

Code	Delivery pressure
02	1 to 30 psig (0.007 to 0.2 MPa)
06	2 to 60 psig (0.014 to 0.4 MPa)
10	2 to 100 psig (0.014 to 0.7 MPa)
15	5 to 150 psig (0.034 to 1.0 MPa)

Material

Code	Body	Poppet	Diaphragm
S	316L SS	316L SS	Hastelloy® C-22

Ports

Code	Ports
2PW	2 ports
3PW	3 ports

Porting Configuration

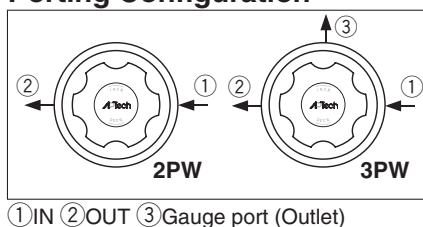

Connections (Inlet①, Outlet②)

Code	Connections
FV12	3/4 inch face seal (Female)
MV12	3/4 inch face seal (Male)
TW12	3/4 inch tube weld
FV16	1 inch face seal (Female)
MV16	1 inch face seal (Male)
TW16	1 inch tube weld

Bonnet option

Code	Bonnet
No code	Standard
P	Panel Installation *3)
BP	Bonnet port (NPT 1/8 inch)

*3) Panel mounting hole: dia.39.6 mm.

Pressure gauge unit *2)

Code	Unit
No code	psig/bar
MPA	MPa

*2) Pressure gauge unit MPa or psig/bar selectable. However under Japanese regulation, only MPa is available in Japan.

Gauge port *1) (Outlet③)

Code	Pressure gauge	
	psig/bar unit	MPa unit
No code	No gauge port	
0	No pressure gauge (Connections: 1/4 inch face seal male)	
V3	-30 in.Hg to 30 psig	-0.1 to 0.2 MPa
L	-30 in.Hg to 60 psig	-0.1 to 0.4 MPa
1	-30 in.Hg to 100 psig	-0.1 to 0.7 MPa
H	-30 in.Hg to 160 psig	-0.1 to 1.1 MPa

*1) Other range available. Refer to gauge guide (P.94).

Specifications

Operating Parameters		AZ9202	AZ9206	AZ9210	AZ9215
Delivery pressure		1 to 30 psig (0.007 to 0.2 MPa)	2 to 60 psig (0.014 to 0.4 MPa)	2 to 100 psig (0.014 to 0.7 MPa)	5 to 150 psig (0.034 to 1.0 MPa)
Gas					
Select compatible materials of construction for the gas					
Source pressure		Vacuum to 300psig (2.1 MPa)			
Proof pressure (Inlet)		450 psig (3.1 MPa)			
Burst pressure		1500 psig (10.3 MPa)			
Ambient and operating temperature		-40 to 160°F (-40 to 71°C) (No freezing)			
Cv		1.6			
Leak rate	Inboard leakage	2 x 10 ⁻¹¹ Pa·m ³ /sec			
	Outboard leakage	1 x 10 ⁻¹⁰ Pa·m ³ /sec			
Across the seat leak		4 x 10 ⁻⁹ Pa·m ³ /sec			
Surface finish		Ra 10 μin. (0.25 μm)			
Connections		Face seal, Tube weld			
Supply pressure effect		7 psig (0.048 MPa) rise in delivery pressure per 100 psig (0.7 MPa) source pressure drop			
Installation		Bottom mount (Option: panel mount)			
Internal volume		2.2 in ³ (36 cm ³)			

Single Stage Regulator for Ultra High Purity *Series AZ9200*

High flow(Tied-diaphragm)

Recommendations

Regulators

AP

SL

AZ

AK

KT

BP

Diaphragm Valves

Check Valves

Vacuum Generators

Flow Switches

Technical Data/
Glossary of Terms

Precautions

Wetted Parts Material

Wetted Parts	S
Body	316L SS
Surface finish	Electropolish + Passivation
Nozzle	316L SS
Poppet	316L SS
Diaphragm	Hastelloy® C-22
Seat	PFA

Dimensions

inch (mm)

AZ9200

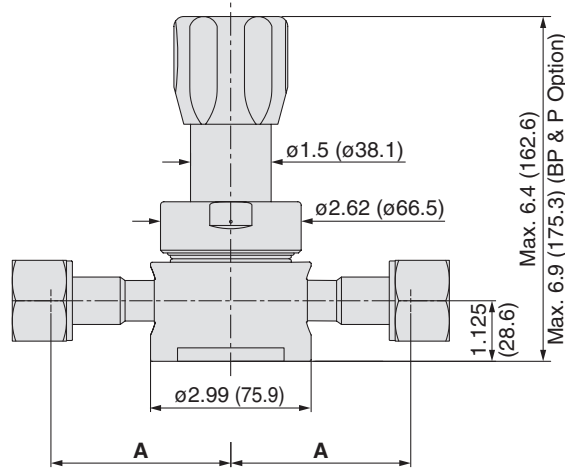

Connections	A	
	inch	(mm)
FV12	3.39	(86.1)
MV12	3.00	(76.2)
FV16	3.67	(93.2)
MV16	3.00	(76.2)

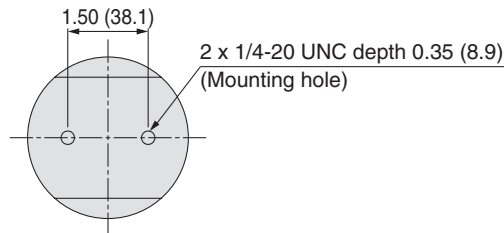

Flow Characteristics

AZ9200 Inlet pressure: - - - - 150 psig (1.0 MPa) — 100 psig (0.69 MPa)

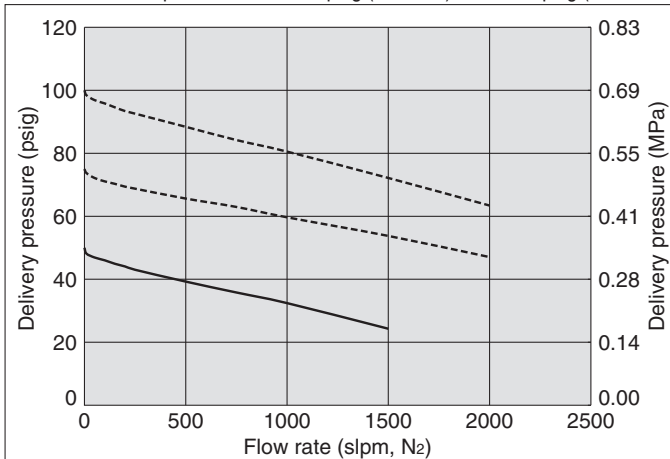

Single Stage Regulator for Ultra High Purity

Delivery of sub-atmospheric pressure

Series AZ1100

- For UHP gas delivery
- Sub-atmospheric to low positive pressure delivery
- Flow capacity to 0.5 slpm
- Body material: 316L SS
- Hastelloy internals available for corrosion resistance



How to Order

Port Number
① ② ③ ④

AZ11 01 S [] 2PW FV4 FV4 [] [] [] []

Delivery pressure

Code	Delivery pressure
01	100 mm Hg absolute to 10 psig (-88 kPa to 0.07 MPa)

Material

Code	Body	Poppet	Diaphragm	Nozzle
S	316L SS	316L SS	316L SS	316L SS
SHP	316L SS	Hastelloy® C-22	Hastelloy® C-22	316L SS

Surface finish

Code	Surface finish Ra
No code	10 μin. (0.25 μm) Standard
Q	25 μin. (0.62 μm)

Ports

Code	Ports
2PW	2 ports
3PW	3 ports
4PW	4 ports

Connections (Inlet ①, Outlet ②)

Code	Connections
FV4	1/4 inch face seal (Female)
MV4	1/4 inch face seal (Male)
FV6	3/8 inch face seal (Female)
MV6	3/8 inch face seal (Male)
TW6	3/8 inch tube weld

Bonnet option

Code	Bonnet
No code	Standard
P	Panel installation *4)
BP	Bonnet port (NPT 1/8 inch)

*4) Panel mounting hole: dia. 1.56 inch (39.6 mm).

Seat material

Code	Material
No code	PCTFE (Standard)
TF	PTFE *3)

*3) PTFE recommended for applications such as within a process tool.

Pressure gauge unit *2)

Code	Unit
No code	psig/bar
MPA	MPa

*2) Pressure gauge unit MPa or psig/bar selectable. However under Japanese regulation, only MPa is available in Japan.

Gauge port (Inlet ③, Outlet ④)

Code	Pressure gauge *1)	
	psig/bar unit	MPa unit
No code	No gauge port	
0	No pressure gauge (Connections: 1/4 inch face seal male)	
V3	-30 in.Hg to 30 psig	-0.1 to 0.2 MPa
L	-30 in.Hg to 60 psig	-0.1 to 0.4 MPa

*1) Other range available. Refer to gauge guide (P.94).

Porting Configuration

① IN ② OUT ③ Gauge port (Inlet)
④ Gauge port (Outlet)

Sample Order Number

	Port ①	Port ②	Port ③	Port ④
AZ1101S	2PW	FV4	FV4	
	3PW	FV4	FV4	0
	3PW	FV4	FV4	V3 MPA
	4PW	FV4	FV4	V3 V3 MPA

Specifications

Operating Parameters		AZ1101
Delivery pressure		100 mm Hg absolute to 10 psig (-88 kPa to 0.07 MPa)
Gas		Select compatible materials of construction for the gas
Source pressure		Vacuum to 300 psig (2.1 MPa)
Proof pressure (Inlet)		500 psig (3.4 MPa)
Burst pressure		8000 psig (55.2 MPa)
Ambient and operating temperature		-40 to 160°F (-40 to 71°C) (No freezing)
Cv		0.05
Leak rate	Inboard leakage	2 x 10 ⁻¹¹ Pa·m ³ /sec
	Outboard leakage	2 x 10 ⁻¹⁰ Pa·m ³ /sec *1)
Across the seat leak		4 x 10 ⁻⁹ Pa·m ³ /sec *1)
Surface finish		Ra 10 μin. (0.25 μm) Option: 25 μin. (0.62 μm)
Connections		Face seal, Tube weld
Installation		Bottom mount (Option: panel mount)
Internal volume		0.49 in ³ (8 cm ³)
Mass		2.76 lbs (1.25 kg) *2)

*1) Tested with Helium gas inlet pressure 300 psig (2.1 MPa).

*2) Mass, including individual boxed weight, may vary depending on connections or options.

Single Stage Regulator for Ultra High Purity *Series AZ1100*

Delivery of sub-atmospheric pressure

Wetted Parts Material

Wetted Parts	S	SHP
Body	316L SS	
Surface finish	Electropolish + Passivation	
Poppet	316L SS	Hastelloy® C-22
Diaphragm	316L SS	Hastelloy® C-22
Nozzle	316L SS	
Seat	PCTFE (Option: PTFE)	

Dimensions

inch (mm)

AZ1100

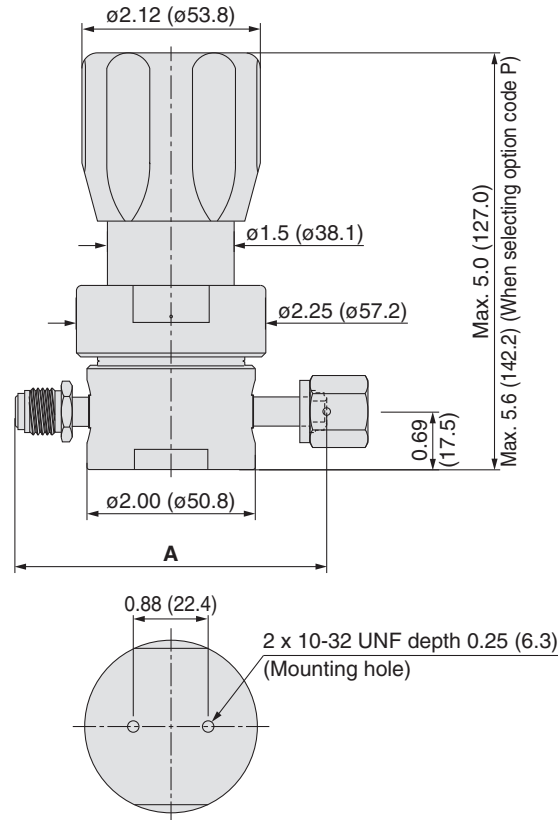

Connections	A	
	inch	(mm)
FV4	3.70	(94.0)
MV4		
FV6	4.70	(119.4)
MV6		
TW6	2.96	(75.2)

Flow Characteristics

AZ1100

Inlet pressure: 2 psig (14 kPa)

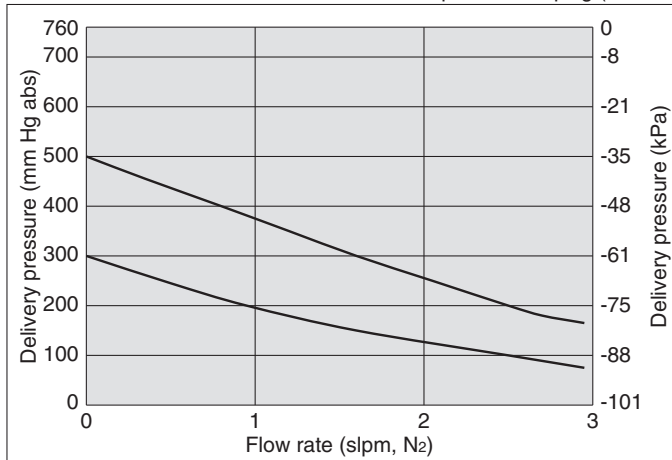

Hastelloy® is a registered trademark of Haynes International.



Regulator Pressure Gauges Guide

For AP/SL/AZ series (Installed before shipment^{*1)} / Order separately)

Specifications

Installation	Lower mount	
Gas	Select compatible materials of construction for the gas	
Connections	1/4 inch face seal (Female)	
Temperature range	-40 to 140°F (-40 to 60°C) (No freezing)	
Accuracy	25% to 75% of the scale: ±1%F.S. Other than above: ±2%F.S. (ASME B40.1 Grade A)	
Cleanliness	ASME B40.1 level IV	
No oil	No oil	
Material	Case	Stainless steel
	Window	Polycarbonate
	Socket	316L SS
	Bourdon tube	316L SS

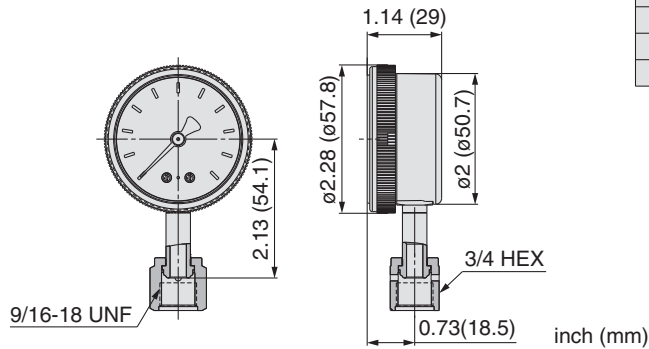

Model

Regulator Code ^{*2)}		Pressure range	Unit	Part number ^{*3)}		
gauge port	unit					
V3	(No code)	-30 in.Hg to 30 psig	psig/bar ^{*4)}	00-83000023		
L		-30 in.Hg to 60 psig		00-83000026		
1		-30 in.Hg to 100 psig		00-83000021		
H		-30 in.Hg to 160 psig		00-83000116		
2		0 to 200 psig		00-83000020		
4		0 to 400 psig		00-83000007		
10		0 to 1000 psig		00-83000022		
40		0 to 4000 psig		00-83000024		
V3		MPa		-0.1 to 0.2 MPa	MPa	00-83000304
L				-0.1 to 0.4 MPa		00-83000305
1	-0.1 to 0.7 MPa		00-83000300			
H	-0.1 to 1.1 MPa		00-83000297			
2	0 to 1.4 MPa		00-83000299			
4	0 to 3 MPa		00-83000301			
10	0 to 7 MPa		00-83000302			
40	0 to 28 MPa		00-83000303			

For AK/BP series (Installed before shipment / Order separately)

Stainless steel / Lower mount

Specifications

Installation	Lower mount	
Gas	Select compatible materials of construction for the gas	
Connections	NPT 1/4 inch	
Temperature range	-40 to 140°F (-40 to 60°C) (No freezing)	
Accuracy	25% to 75% of the scale: ±2%F.S. Other than above: ±3%F.S. (ASME B40.1 Grade B or better)	
Cleanliness	ASME B40.1 level IV	
No oil	No oil	
Material	Case	Stainless steel
	Window	Polycarbonate
	Socket	316L SS
	Bourdon tube	316L SS

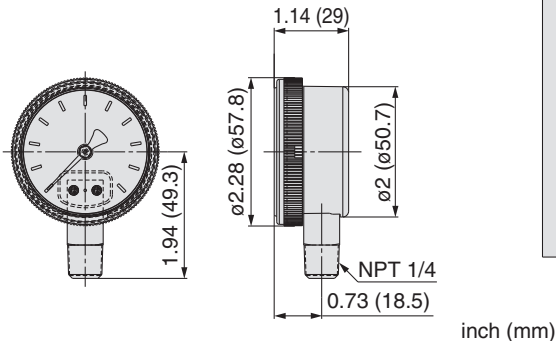

Model

Regulator Code ^{*2)}		Pressure range	Unit	Part number ^{*3)}	
material	gauge port				
S SH	V15	(No code)	psig/bar ^{*4)}	00-83000102	
	V3			-30 in.Hg to 30 psig	00-83000184
	L			-30 in.Hg to 60 psig	00-83000181
	1			-30 in.Hg to 100 psig	00-83000182
	H			-30 in.Hg to 160 psig	00-83000196
	V2			-30 in.Hg to 200 psig	00-83000033
	2			0 to 200 psig	00-83000193
	4			0 to 400 psig	00-83000194
	10			0 to 1000 psig	00-83000187
	30			0 to 3000 psig	00-83000234
	40	0 to 4000 psig	00-83000183		
	V15	MPa	MPa	00-83000287	
	V3			-0.1 to 0.2 MPa	00-83000288
	L			-0.1 to 0.4 MPa	00-83000289
	1			-0.1 to 0.7 MPa	00-83000290
	H			-0.1 to 1.1 MPa	00-83000291
	V2			-0.1 to 1.4 MPa	00-83000292
	2			0 to 1.5 MPa	00-83000286
	4			0 to 3 MPa	00-83000285
	10			0 to 7 MPa	00-83000284
30	0 to 21 MPa			00-83000283	
40	0 to 28 MPa	00-83000282			

*1) If one prefers shipment with the pressure gauges installed on the regulator, the material of gasket to be used on the connections will be Nickel (no plated). Please contact SMC for details if one prefers changing this material.

*2) When pressure gauge needs to be assembled with regulator when shipment, put this code as gauge port in How to Order.

Regulator / Pressure Gauges Guide

For **AK/BP** series (Installed before shipment / Order separately)

Stainless steel / Center back mount

Specifications

Installation	Center back mount	
Gas	Select compatible materials of construction for the gas	
Connections	NPT 1/4 inch	
Temperature range	-40 to 140°F (-40 to 60°C) (No freezing)	
Accuracy	25% to 75% of the scale: ±2%F.S. Other than above: ±3%F.S. (ASME B40.1 Grade B or better)	
Cleanliness	ASME B40.1 level IV	
No oil	No oil	
Material	Case	Stainless steel
	Window	Polycarbonate
	Socket	316L SS
	Bourdon tube	316L SS

Model

Regulator Code	Pressure range	Unit	Part number *3)
*5)	-30 in.Hg to 100 psig	psig/bar *4)	00-83000224
	-30 in.Hg to 160 psig		00-83000272
	-0.1 to 0.7 MPa	MPa	00-83000293
	-0.1 to 1.1 MPa		00-83000294

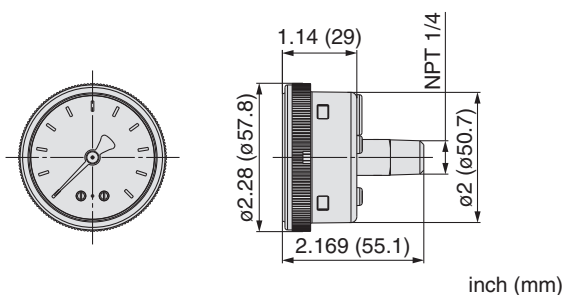

Brass / Lower mount

Specifications

Installation	Lower mount	
Gas	Select compatible materials of construction for the gas	
Connections	NPT 1/4 inch	
Temperature range	-40 to 140°F (-40 to 60°C) (No freezing)	
Accuracy	25% to 75% of the scale: ±2%F.S. Other than above: ±3%F.S. (ASME B40.1 Grade B or better)	
Cleanliness	ASME B40.1 level IV	
No oil	No oil	
Material	Case	Brass
	Window	Polycarbonate
	Socket	Brass
	Bourdon tube	Phosphor bronze

Model

Regulator Code *2)	material gauge port	unit	Pressure range	Unit	Part number *3)		
						B	V3
	L	-30 in.Hg to 60 psig	00-83000177				
	1	-30 in.Hg to 100 psig	00-83000178				
	H	-30 in.Hg to 160 psig	00-83000239				
	2	0 to 200 psig	00-83000218				
	4	0 to 400 psig	00-83000205				
	10	0 to 1000 psig	00-83000186				
	40	0 to 4000 psig	00-83000179				
	V3	MPA	-0.1 to 0.2 MPa	MPa	00-83000278		
	L		-0.1 to 0.4 MPa		00-83000279		
	1		-0.1 to 0.7 MPa		00-83000280		
	H		-0.1 to 1.1 MPa		00-83000281		
	2		0 to 1.5 MPa		00-83000277		
	4		0 to 3 MPa		00-83000276		
	10		0 to 7 MPa		00-83000275		
	40		0 to 28 MPa		00-83000274		

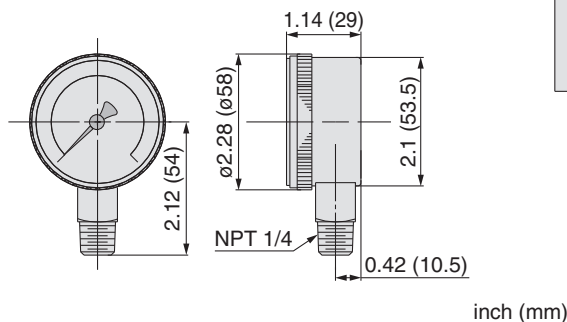

*3) Part number of pressure gauge itself. Gauge are shipped separately.
*4) Under Japanese regulation, psig/bar unit gauge is not sold in Japan.
*5) Available for special order. Please contact SMC.



Process Gas Equipment / Regulator Specific Product Precautions

Be sure to read before handling. Refer to back cover for Safety Instructions and P. 145 and 146 and the "Operation Manual" for common precautions. Operation manual is available from the SMC web site. <http://www.smcworld.com>

Selection

Warning

1. Confirm the specifications.

When selecting the product, confirm the operating conditions, such as type of gas, operating pressure (inlet and outlet), flow rate, operating temperature etc., and use within the operating range specified in the catalog. The product may not be suitable for use with specific gases and applications/ environments. Check the compatibility of the product materials with the process gas.

Design the equipment and select the product by understanding the characteristics of gas.

2. Confirm allowable pressure of any pressure gauges.

When installing a pressure gauge to the product, operating pressure should not exceed the maximum allowable pressure of the pressure gauge.

Mounting

Warning

1. Confirm the mounting direction of the product.

The high pressure (inlet) port is labeled with an "HP" mark and the low pressure (outlet) port is labeled with an "LP" mark. In the case of two stage regulator, the monitor port of first stage outlet pressure is labeled with "MP" mark.

Make sure to connect the port labeled with "HP" mark, to the high pressure. If any of the ports, other than "HP", are connected to the high pressure, it may cause damage or gas leakage.

2. After installation, check internal leakage (leakage across seat) of the product.

Check internal leakage (leakage across seat) with inert gases such as nitrogen, etc., and select the most appropriate test method depending on the application. The following procedures are an example of how a test may be performed. It is intended as an overview and not as an all inclusive description.

- 1) Rotate the adjustment wheel counterclockwise (DECR) completely to relieve spring force. Then gradually open the valve at inlet side to supply gas to the regulator.
- 2) Close the valves on the inlet and outlet side and hold for at least 10 minutes. Then confirm the outlet pressure.
- 3) Rotate the adjustment wheel clockwise (INCR) until the outlet pressure reaches the outlet pressure setting. Then hold for at least 10 minutes and confirm the outlet pressure.

If outlet pressure continues increasing in steps 2) and 3) above, the regulator may have internal leakage (leakage across seat) and you should stop using the regulator immediately and contact SMC or sales representative.

3. Purge hazardous gases from system before removing regulator from system.

Before removing regulators from system, fully open regulator by turning adjustment wheel clockwise (INCR), and follow proper procedures to flush system with inert gas such as nitrogen to remove any residual hazardous gases.

Maintenance

Warning

1. If a regulator requires repair, contact SMC.

Operation

Warning

1. Do not use the regulator as shutoff valve or safety valve.

2. Do not rotate the adjustment wheel counterclockwise (DECR) under no flow conditions.

If the adjustment wheel is rotated counterclockwise (DECR) under no flow conditions but there is residual pressure remaining in outlet side, it may cause damage to the regulator. Decreasing of the setting pressure should be done under flow conditions.

3. Do not pressurize the regulator from outlet side. If high pressure, which exceeds the setting pressure, is supplied from outlet side, it may cause damage to the regulator.

4. Supply gas to the regulator.

Rotate the adjustment wheel counterclockwise (DECR) completely to relieve spring force. Then, gradually open the valve at inlet side to supply gas to the regulator. When operating the valve, do not stand in front of the regulator and pressure gauge. If the valve at inlet side is opened rapidly, high pressure gas might be supplied into outlet side of the regulator and it may cause severe damage or burst the device.

5. Adjust pressure.

When rotating the adjustment wheel clockwise (INCR), outlet pressure will increase.

In order to adjust precisely, the wheel should be adjusted at the desired flow conditions.

6. Decreasing the setting pressure under flow conditions.

When decreasing the setting pressure, make sure to open the valve at outlet side to keep flow conditions. When rotating the adjustment wheel counterclockwise (DECR) under flow conditions, setting pressure will decrease.

7. Stop using the regulator immediately if resonance occurs.

Loud audible noise as well as vibration of device or fluctuation of outlet pressure (resonance) may occur depending on operating conditions etc. If this situation occurs, stop using the regulator immediately and contact SMC or sales representative.



Process Gas Equipment / Back Pressure Regulator Specific Product Precautions

Be sure to read before handling. Refer to back cover for Safety Instructions and P. 145 and 146 and the “Operation Manual” for common precautions. Operation manual is available from the SMC web site. <http://www.smcworld.com>

Selection

Warning

1. Confirm the specifications.

When selecting the product, confirm the operating conditions, such as type of gas, operating pressure (inlet and outlet), flow rate, operating temperature etc., and use within the operating range specified in the catalog. Verify flow capacity of regulator and vent or return line, are large enough to vent off gas source without creating excessive backpressure. The product may not be suitable for use with specific gases and applications/environments. Check the compatibility of the product materials with the process gas. Design the equipment and select the product by understanding the characteristics of gas.

2. Confirm allowable pressure of any pressure gauges.

When installing pressure gauges to the product, operating pressure should not exceed the maximum allowable pressure of the pressure gauge.

Mounting

Warning

1. Confirm the mounting direction of the product.

The high pressure (inlet) port is labeled with an “IN” mark and the low pressure (outlet) port is labeled with an “OUT” mark. Make sure to connect the port labeled with “IN” mark, to the high pressure. If any of the ports, other than “IN”, is connected to the high pressure, it may cause damage or gas leakage.

Maintenance

Warning

1. If a back pressure regulator requires repair, contact SMC.

Operation

Warning

1. Do not use the back pressure regulator as shutoff valve or safety valve.

2. Pressure control

- 1) Rotate the adjustment wheel counterclockwise completely to relieve spring force.
- 2) Partially open the valve at inlet side to supply gas to the back pressure regulator.
- 3) Increase the inlet pressure to the setting pressure by rotating the adjustment wheel clockwise.
- 4) Continue opening the valve at inlet side monitoring the inlet pressure. When the inlet pressure increases above the setting pressure, rotate the adjustment wheel counterclockwise to relieve the inlet pressure to the setting pressure.
- 5) Open the valve at inlet side completely and confirm that the inlet pressure reaches the setting pressure.

3. Decreasing the setting pressure.

When decreasing the setting pressure, make sure to gradually rotate the adjustment wheel counterclockwise until the inlet pressure reaches the setting pressure.

4. Stop using the regulator immediately if resonance occurs.

Loud audible noise as well as vibration of device or fluctuation of outlet pressure (resonance) may occur depending on operating conditions, etc. If this situation occurs, stop using the regulator immediately and contact SMC or sales representative.

Recommendations

Regulators

AP

SL

AZ

AK

KT

BP

Diaphragm Valves

Check Valves

Vacuum Generators

Flow Switches

Technical Data/
Glossary of Terms

Precautions

Technical Data/Glossary of Terms

1. Applications

[Process Gas]

A generic term describing gases used in manufacturing which contact the product being manufactured (processed).

[Specialty Gas]

A generic term describing gases stored in cylinders (bottles). These gases range from non-hazardous inert to hazardous - corrosive, poisonous, flammable, oxidizer and pyrophoric.

[Bulk Gas]

A generic term used to describe gases stored in large vessels. The most common bulk gases are stored in liquid phase, such as nitrogen and oxygen.

[CDA]

Clean dry air, generally supplied by a compressor rather than a cylinder (bottle).

[Ultra High Purity (UHP)]

A term common to the semiconductor industry and other clean industries such as solar, LED and flat panel display, used to describe extremely high purity and very low contamination requirements. Gases are of the highest level of purity attainable and gas handling systems and components are designed to maintain such purity without contributing contamination to the gas stream.

[General Applications]

This term indicates all industries other than semiconductor and clean industries such as solar, LED and flat panel display, and applications that are not UHP.

[Source (Cylinder) Applications]

Defines products used at gas storage vessel, such as a cylinder (bottle) pressure regulator used to decrease source pressure to a lower line pressure. For the purposes of this catalog, components are defined as 'source' if they are the cylinder pressure regulator or upstream of the cylinder regulator.

[Distribution Applications]

Defines products used downstream of source regulator which includes point of use, distribution panels such as valve manifold boxes (VMB) and within the process tool. For the purposes of this catalog, components downstream of the source regulator are defined as 'distribution'.

[Bulk Gas Applications]

Defines products used for source and distribution applications of bulk gases, including BSGS (bulk specialty gas systems).

[Sub-atmospheric Applications]

Source and distribution applications where pressure delivery is less than atmospheric pressure. This is common for low vapor pressure specialty gas delivery.

2. Products

[Regulator]

A control valve that works by reducing the valve inlet pressure and delivering a lower outlet pressure. Most AP Tech regulators are non-relieving type, which means pressure above set point is not vented automatically.

[Single stage]

Single stage pressure regulators drop pressure only once in a single step.

[Two stage]

Two stage regulation drops pressure twice, in two steps. A two stage regulator is simply two regulators in series with a common body. Two stage regulations are two separate regulators in series.

[Tied-diaphragm]

This is a regulator design in which the diaphragm and poppet are linked together. The tied diaphragm feature pulls the poppet closed as the pressure rises above set point and stops leak due to contamination or some other failures.

[Springless Regulator]

These are pressure regulators which do not have wetted springs below the poppet. The diaphragm and poppet are linked, as with the tied diaphragm, but it also does not have a poppet spring.

[Back pressure regulator]

This is a control valve that if the pressure on the inlet side exceeds a set level, the over pressure is vented to outlet side to keep the inlet pressure stable.

[Diaphragm valve]

This is a shut off valve which uses a diaphragm for a moving element to open and close the valve. Springless diaphragm valves do not have a wetted spring. Diaphragm valves from AP Tech are two way valves, available with multiple ports.

[LOTO]

Stands for Lock-out/Tag-out and is used to ensure worker's safety. Lock-out refers to physically locking the device to shutoff gas supply to equipment. Tag-out refers to the practice of attaching a warning tag to the device to prevent potential accidents caused by erroneous operations.

[Purge port]

Purge ports can be located on the inlet and/or outlet side of the valve. It can be used in applications, such as applying purge gas when welding on the line or maintenance service while valve is closed.

[Check valve]

A check valve is a safety device intended to prevent reverse flow. The AP 64 is a unique design with only one moving part in the gas stream, an O-ring. It is a springless design, free of springs and poppets.

[Vacuum generator]

A venturi device that creates vacuum by flowing gas through a nozzle. The AP 71 and 72 are module devices which combine a supply valve and check valve with the venturi.

[Constant bleed]

A feature that provides a continuous flow of gas through the valve via an orifice when it is closed. This feature is used with the AP 71 and AP 72 series to keep exhaust lines inert. It is also available as an option to certain standard shut off valves to provide a bleed to keep the cylinder connection inert while disconnected from a cylinder.

[Flow switch]

A sensor that detects excess flow above a given flow rate, caused by pipe breakage etc.

Note that the AP 4 and AP 74B series are simple switches and do not have a flow rate display function.

3. Materials

[316 SS]

An austenitic stainless steel with a higher nickel content to improve its corrosion resistance.

[316L SS]

A low-carbon form of 316 SS which has better intergranular corrosion resistance than 316 SS.

Technical Data/Glossary of Terms

[316L SS secondary remelt]

A high-grade form of 316L SS to reduce impurities to the utmost limit.

AP Tech 316L SS secondary remelt steel conforms to the SEMI standard F20 UHP grade.

[Hastelloy®] Trademark of Haynes International

A nickel-chromium-molybdenum alloy with excellent corrosion resistance.

[Elgiloy®] Trademark of Elgiloy Specialty Metals

A cobalt-chromium-nickel alloy with excellent corrosion resistance and superelasticity. This material is used as diaphragm of the diaphragm valves.

[PCTFE]

Poly Chloro Tri Furuoro Ethylene. This is high transparency fluoroplastic material with mechanically superior in rigidity and excellent low temperature. This material is used as standard seat material of the regulators and diaphragm valves.

[PTFE]

Fully fluorinated material. This is virtually chemically inert. PTFE should have equivalent or superior chemical compatibility compared to PCTFE in every application. PTFE (TF) option available for the AP 500, AP, AZ & AK 1000 & 1100 and AZ & AK 1300. The primary application for this material is for pressure regulators inside process tools.

[VespeI®] Trademark of DuPont

Plastic with excellent heat resistance (polyimide resin). This material has excellent heat and wear resistance. This seat is available as an option for high temperature applications or specific gas applications, such as N₂O or CO₂.

[PEEK]

Polyetheretherketone. This material has excellent heat, fatigue and chemical resistances as thermoplastic resin. This seat is available as an option for the regulators.

[Viton®] Trademark of DuPont

Fluoro-rubber (FKM). This material has excellent heat and chemical resistances.

[Kalrez®] Trademark of DuPont

Perfluoroelastomer (FFKM). This material has excellent heat and chemical resistances compared to fluoro-rubber (FKM).

4. Surface treatment

[Electropolish]

Commonly referred to as EP, is an electrolytic process for metals to enhance a surface chemistry and smooth the surface finish.

[Passivation]

A process for metals to form a passivation layer on the surface, typically by removing surface Fe in a nitric acid bath.

5. Connections

[Face seal fitting]

A fitting type in which a metal gasket effects a seal with mating fittings, forming high leak integrity, metal to metal seal. The most common face seal fitting is VCR® compatible type.

[Tube weld]

Components with tube stubs are installed by welding into the piping system directly without using fittings.

[Compression fitting]

A self aligning tube fitting that uses a ferrule to compress on the tubing effecting a seal when the nut is tightened. A common compression fitting is that of Swagelok®.

[NPT]

A tapered pipe thread which is a U.S.A standard (ANSI).

6. Specifications

[Surface finish Ra]

Surface finish of the inner surface (wetted parts). A standard for measuring surface roughness which averages the peak to valley of the surface profile over a given distance (stroke). Multiple readings on a part are also averaged for Ra, but for Ra max, the worst reading is the value for that part.

[Cv factor]

The flow coefficient, Cv, is defined as the volume of 15.6°C water passing through a valve with specific differential inlet to outlet pressures. Cv is calculated in accordance with the SEMI standard F32. Cv measurements of regulators are taken with the orifice of the regulators wide open.

[Cracking pressure]

This is the pressure at which a check valve first opens and achieves a given flow rate as pressure increase.

[Ultimate vacuum]

The maximum vacuum generated by a vacuum generator.

[slpm]

Abbreviation for standard liter per minute.

Indicates the volumetric flow in liters per minute of time at standard conditions of a temperature of 0°C and a pressure of 1 atmosphere.

[Supply pressure effect]

The change in a pressure regulator's outlet pressure resulting from a change in source (supply) pressure. The most typical is an increase in outlet pressure as the inlet pressure decays – often stated as a given rise per a given drop in pressure.

[Inboard leakage]

Leakage rate from outside to inside of the products occurring when an internal pressure is less than the external pressure. This can be detected by spraying helium on outside of the products and detecting helium entering into the products from any leak path while internal cavities are evacuated. This detection method conforms to the SEMI standard F1.

[Outboard leakage]

Leakage rate from inside to outside of the products occurring when an internal pressure is more than the external pressure. This can be detected by pressurizing helium inside the products and detecting helium leaking outside from the products. This detection method conforms to the SEMI standard F1.

[Across the seat leak]

Leak rate from inlet to outlet of a device in the closed position. Often also referred to as 'internal leakage' meaning leak is only internal from inlet to outlet side.

[SEMI standards]

Voluntary standards issued by Semiconductor Equipment and Materials International (SEMI) an international industry association made up of companies that supply manufacturing equipment, materials and related services to the semiconductor, flat panel display, nanotechnology, MEMS, solar power generation and other related industries.



Process Gas Equipment Common Precautions 1

Be sure to read before handling.

Design

⚠ Warning

1. Confirm the specifications.

The compatibility of the product with specific equipment must be decided by the person who designs the equipment or decided its specifications based on necessary analysis and test results. The expected performance and safety assurance of the equipment will be the responsibility of the person who has determined its compatibility with the product.

Selection

⚠ Warning

1. Confirm the specifications.

When selecting the product, confirm the operating conditions, such as type of gas, operating pressure (inlet and outlet), flow rate, operating temperature etc., and use within the operating range specified in the catalog. The product may not be suitable for use with specific gases and applications/ environments. Check the compatibility of the product materials with the process gas.

Design the equipment and select the product by understanding the characteristics of gas.

2. Follow the regulations and laws, defined by the country or local government, or organization standards.

Reference: High Pressure Gas Safety Act, Labor Safety and Sanitation Law etc.

Mounting

⚠ Warning

1. Operation Manual

Mount and operate the product after reading the manual carefully and understanding its contents. Also keep the manual where it can be referred to as necessary.

⚠ Caution

1. Flush the piping thoroughly with inert gas before installing the products.

Remove any dust or scales thoroughly as they could cause malfunction or failure of the product. Do not flush with gas other than inert gas, as this could cause dangerous situations.

2. Do not touch the fitting or the wetted parts of the products by hand. Do not apply grease or oil to the products.

3. Unpack the hermetically-sealed package under clean environment (other than AK series).

The products intended for high purity processes are double packed inside the clean room. Make sure to unpack the sealed inner bag inside the clean room or clean environment.

4. Ensure sufficient space for maintenance activities.

Ensure sufficient space for maintenance activities.

Mounting

⚠ Caution

5. Connect face seal fittings.

Follow the procedures, recommended from the fitting manufacturer, to connect properly. Typically 1/8 turn past finger tight of the nut.

6. Connect tube welds.

Follow the industry standards (refer to SEMI F78) to weld the piping.

7. Connect compression fittings.

Follow the procedures, recommended from the fitting manufacturer, to connect properly.

Typically 1-1/4 turn past finger tight of the nut after inserting the tube into the fitting.

8. Connect NPT thread fittings.

Thread fitting or piping into body and tighten it at recommended torque. When holding the product, hold its body section.

Apply PTFE tape or sealant on the thread of the piping, fitting, etc. When using the sealant, other than the PTFE, it will be difficult to fully remove the sealant and this could cause malfunction or failure of the product.

9. After installation, perform a leak test.

Perform a leak test, such as helium leak test, pressure decay test, bubble leak test, etc., depending on the application. It is recommended to perform a helium leak test on all face seal connections and tube welds per the industry standards (refer to SEMI F1).

Storage and Operating Environment

⚠ Warning

1. Do not use in an area having chemicals, sea water or water, or where there is direct contact with any of these.

2. Do not use in a place subject to heavy vibration and/or shock.

3. Keep ambient temperature and use gas within the specified operating temperature. Remove any sources of excessive heat.

4. Do not keep the products in stock in an area, where any dust or water coming in, and keep in dry conditions, where there is no contact with humidity.



Process Gas Equipment Common Precautions 2

Be sure to read before handling.

Maintenance

Warning

1. Perform a routine maintenance.

Perform a routine maintenance at customer's responsibility by taking into consideration the operating conditions of the equipment. It is recommended to perform a routine maintenance for the following:
External leakage, Internal leakage (Across the seat leak), Performance etc.

2. Shut down system before removing the product from system for repair or replacement.

Follow the proper procedures to shut off the process gas supply and vent the system.

3. Purge hazardous gases from system before removing the product from system.

4. Do not disassemble products under warranty.

The warranty may be voided if product is disassembled.

Operation

Warning

1. Do not put the heavy objects on the products. Do not use the products as scaffold.

2. Do not use the products in conditions that do not meet the product specifications.

Product Returns

When returning the product to SMC, make sure to properly purge to remove all hazardous materials and return the product complying with SMC specified procedures.
For details, please contact SMC.

Export

Warning

The products fall within the United States Export Administration Regulations (EAR) regarding sale, export and re-exports. It is the exporter's responsibility to assure that these regulations are followed when the products are exported. Export Control Classification Number (ECCN) related to the products is as follows.

Regulations (including ECCN) are subject to change with amendment of law.

Latest information regarding these regulations should be checked by customer.

Reference: Bureau of Industry and Security (USA)
<http://www.bis.doc.gov/>

1) **2B350.g.2** <Applicable conditions>

- (1) Product name : Regulator, Diaphragm valve
- (2) Body material : Hastelloy®
- (3) Connection size : 1/2 inch or more

2) **2B999.g** <Applicable conditions>

- (1) Product name : Regulator, Back pressure regulator, Diaphragm valve, Check valve, Vacuum generator module (integrated with valve and check valve)
- (2) Body material : 316 SS, 316L SS, 316L SS secondary remelt, Hastelloy* regardless of connection size.



* 2B350.g.2 supersedes for regulator and diaphragm valve of Hastelloy body with 1/2 or more connection size.

3) **EAR99** <Applicable conditions>

- (1) Regulator and Back pressure regulator with brass bodies
- (2) Vacuum generator, Flow switch, Other options (Pressure gauge, LOTO)

Safety Instructions

These safety instructions are intended to prevent hazardous situations and/or equipment damage. These instructions indicate the level of potential hazard with the labels of “**Caution**”, “**Warning**” or “**Danger**”. They are all important notes for safety and must be followed in addition to International Standards (ISO)*¹, Japan Industrial Standards (JIS)*² and other safety regulations*³.

-  **Caution:** Operator error could result in injury or equipment damage.
-  **Warning:** Operator error could result in serious injury or loss of life.
-  **Danger :** In extreme conditions, there is a possibility of serious injury or loss of life.

- *1) ISO 4414: Pneumatic fluid power -- General rules relating to systems.
- *2) JIS B 8370: General rules for pneumatic equipment.
- *3) High Pressure Gas Safety Act, Labor Safety and Sanitation Law etc.

Warning

1. The compatibility of the product is the responsibility of the person who designs the equipment or decides its specifications.

Since the product specified here is used under various operating conditions, its compatibility with fluid and specific equipment must be decided by the person who designs the equipment or decided its specifications based on necessary analysis and test results.

The expected performance and safety assurance of the equipment will be the responsibility of the person who has determined its compatibility with the product. This person should also thoroughly review all specifications of the product referring to its latest catalog information, with a view to giving due consideration to any possibility of equipment failure when configuring the equipment.

2. Only personnel with appropriate training should install and operate machinery and equipment.

The product specified here may become unsafe if handled incorrectly. The assembly, installation operation maintenance of the given equipment including our products must be performed by an operator who is appropriately trained and experienced.

3. Do not service or attempt to remove product and machinery/equipment until safety is confirmed.

1. The inspection and maintenance of machinery/equipment should only be performed after measures to prevent falling or runaway of the driven objects have been confirmed.
2. When the product is to be removed, confirm that the safety measures as mentioned above are implemented and the power from any appropriate source is cut, and read and understand the specific product precautions of all relevant products carefully.
3. Before machinery/equipment is restarted, take measures to prevent unexpected operation and malfunction.

4. Contact SMC beforehand and take special consideration of safety measures if the product is to be used in any of the following conditions.

1. Conditions and environments outside of the given specifications, or outdoors (use in a place protected from adverse environmental).
2. Installation on equipment in conjunction with atomic energy, railways, air navigation, space, shipping, vehicles, military, medical treatment, combustion, or recreation, or equipment in contact with food and beverages, emergency stop circuits, clutch and brake circuits in press applications, safety equipment or other applications unsuitable for the standard specifications described in the product catalog.
3. An application which could have negative effects on people, property, or animals requiring special safety analysis.

Caution

1. The product is provided for use in manufacturing industries.

The product herein described is basically provided for peaceful use in manufacturing industries.

If considering using the product in other industries, consult SMC beforehand and exchange specifications or a contract if necessary.

If anything is unclear, contact your nearest sales branch.

Limited Warranty and Disclaimer/ Compliance Requirements

The product used is subject to the following “Limited Warranty and Disclaimer” and “Compliance Requirements”.

Read and accept them before using the product.

Limited Warranty and Disclaimer

1. The warranty period of the product is 1 year after the product is delivered to customer from SMC.
2. For any failure or damage reported within the warranty period which is clearly our responsibility, a replacement product or necessary parts will be provided.
This limited warranty applies only to our product independently, and not to any other damage incurred due to the failure of the product.
3. Prior to using the products, please read and understand the warranty terms and disclaimers noted in the specified catalog for the particular products.

Compliance Requirements

1. When the product is exported, strictly follow the laws required by the Ministry of Economy, Trade and Industry (Foreign Exchange and Foreign Trade Control Law).
2. The products printed in the catalog are USA manufactured products of AP Tech. As such, they fall within the United States Export Administration Regulations (EAR) regarding re-exports.
It is the exporter’s responsibility to assure that these regulations are followed when the products are exported.

 Safety Instructions Be sure to read “Operation Manual” before using.