

Compact Hydraulic Cylinder

CHQ Series

CHQ

CHK

CHN

CHM

CHS

CH2

CHA

Related
Products

D-

CHQ Series



Nominal pressure: **3.5 MPa**

Bore size (mm): 20, 32, 40, 50, 63, 80, 100

Compact Hydraulic Cylinder Double Acting/Single Rod

CH□QB Series

∅20, ∅32, ∅40, ∅50, ∅63, ∅80, ∅100

3.5 MPa

How to Order

CHQB **50** - **30** **D** □ - □

With Auto Switch **CHDQB** **50** - **30** **D** □ - **M9BW** □ - □

With auto switch (built-in magnet)

Mounting: Basic type

Bore size

20	20 mm
32	32 mm
40	40 mm
50	50 mm
63	63 mm
80	80 mm
100	100 mm

Number of auto switches

Nil	2 pcs.
S	1 pc.
n	"n" pcs.

Auto switch type

Nil	Without auto switch
-----	---------------------

* Select applicable auto switch models from the table below.

Cylinder stroke (mm)
Refer to the standard stroke table on page 243.

Action: Double acting

Auto switch type

Nil	Female thread
M	Male thread

* Rod end nut is provided standard for male thread type.

Rod end thread type

Built-in Magnet Cylinder Model
 If a built-in magnet cylinder without auto switch is required, there is no need to enter the symbol for the auto switch. (Example) CHDQB50-100D

Applicable Auto Switches

Refer to pages 431 to 490 for further details on each auto switch.

Type	Special function	Electrical entry	Indicator light	Wiring (output)	Load voltage		Auto switch model		Lead wire length (m)					Pre-wired connector	Applicable load		
					DC	AC	Perpendicular	In-line	0.5 (Nil)	1 (M)	3 (L)	5 (Z)	None (N)				
Solid state auto switch		Grommet	Yes	3-wire (NPN)	5 V, 12 V	—	M9NV	M9N	●	●	●	○	○	—	IC circuit		
				3-wire (PNP)			M9PV	M9P	●	●	●	○	○	—			
		Connector		2-wire	12 V		M9BV	M9B	●	●	○	○	○	—	—		
				J79C	—		●	—	●	●	—	—	—	—	—		
		Diagnostic indication (2-color indicator)		Grommet	3-wire (NPN)		5 V, 12 V	M9NWV	M9NW	●	●	○	○	○	—	IC circuit	
	3-wire (PNP)		24 V		M9PWV		M9PW	●	●	●	○	○	—				
	Connector		2-wire	12 V	M9BWV		M9BW	●	●	●	○	○	○	—			
			3-wire (NPN)	5 V, 12 V	M9NAV ^{*1}		M9NA ^{*1}	○	○	○	○	○	○	IC circuit			
			3-wire (PNP)	12 V	M9PAV ^{*1}		M9PA ^{*1}	○	○	○	○	○	○				
	Diagnostic output (2-color indicator)	Grommet	Yes	2-wire	12 V		M9BAV ^{*1}	M9BA ^{*1}	○	○	○	○	○	—	—		
4-wire				5 V, 12 V	—	F79F	●	—	●	○	○	—	IC circuit				
Reed auto switch		Grommet	Yes	2-wire	24 V	—	A96V	A96	●	—	—	—	—	—	IC circuit		
							—	A72	A72H	●	—	●	—	—		—	
							12 V	100 V	A93V ^{*2}	A93	●	●	●	●		—	—
							5 V, 12 V	100 V or less	A90V	A90	●	—	●	—		—	—
		Connector				Yes	12 V	A73C	—	●	—	●	●	●	—	—	IC circuit
						No	5 V, 12 V	A80C	—	●	—	●	●	●	—	—	IC circuit
						Yes	24 V or less	A79W	—	●	—	●	—	—	—	—	
						No	5 V, 12 V	A79W	—	●	—	●	—	—	—	—	

*1 Water resistant type auto switches can be mounted on the above models, but in such case SMC cannot guarantee water resistance. Consult with SMC regarding water resistant types with the above model numbers.

*2 1 m type lead wire is only applicable to D-A93.

* Lead wire length symbols: 0.5 m Nil (Example) M9NW
 1 m M (Example) M9NWV
 3 m L (Example) M9NWL
 5 m Z (Example) M9NWX
 None N (Example) J79CN

* Solid state auto switches marked "○" are produced upon receipt of order.

* Since there are applicable auto switches other than listed, refer to page 258 for details.

* For details about auto switches with pre-wired connector, refer to pages 474 and 475.

* For mounting D-A93(V), M9C(V), M9C(W), M9C(AV) with ∅2 to ∅50 to a surface other than the port surface, order an auto switch mounting bracket separately. Refer to page 259 for details.

Compact Hydraulic Cylinder **CH□QB Series**

Double Acting/Single Rod: 3.5 MPa

Specifications



Made to order specifications
(For details, refer to page 249)

Symbol	Specifications
-XB10	Intermediate stroke (Using exclusive body)

Bore size (mm)	20	32	40	50	63	80	100
Action	Double acting/Single rod						
Fluid	Hydraulic fluid						
Nominal pressure	3.5 MPa						
Proof pressure	5.0 MPa						
Maximum allowable pressure	3.5 MPa						
Minimum operating pressure	0.3 MPa						
Ambient and fluid temperature	Without auto switch: -10° to 80°C						
	With auto switch: -10° to 60°C						
Piston speed	8 to 100 mm/s						
Cushion	None						
Rod end thread	Standard: Female thread, Male thread						
Stroke length tolerance	$\begin{matrix} +1.0 \\ 0 \end{matrix}$ mm						
Mounting type	Basic type						
Mounting	Through hole						

Note) Refer to page 214 for definitions of terms related to pressure.

Standard Strokes



Bore size (mm)	Standard strokes (mm)
20	5, 10, 15, 20, 25, 30, 35, 40, 45, 50
32	5, 10, 15, 20, 25, 30, 35, 40, 45, 50, 75, 100
40	5, 10, 15, 20, 25, 30, 35, 40, 45, 50, 75, 100
50	10, 15, 20, 25, 30, 35, 40, 45, 50, 75, 100
63	10, 15, 20, 25, 30, 35, 40, 45, 50, 75, 100
80	10, 15, 20, 25, 30, 35, 40, 45, 50, 75, 100
100	10, 15, 20, 25, 30, 35, 40, 45, 50, 75, 100

Note) Consult with SMC regarding the manufacture of strokes other than the above.

Hydraulic Fluid Compatibility

Hydraulic fluid	Compatibility
Standard mineral hydraulic fluid	Compatible
W/O hydraulic fluid	Compatible
O/W hydraulic fluid	Compatible
Water/Glycol hydraulic fluid	Not compatible
Phosphate hydraulic fluid	Not compatible

CHQ

CHK□

CHN

CHM

CHS□

CHZ□

CHA

Related Products

D-□

Theoretical Output

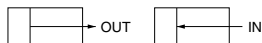

Unit: N

Bore size (mm)	Rod size (mm)	Operating direction	Piston area (mm ²)	Operating pressure (MPa)					
				1	1.5	2	2.5	3	3.5
20	10	OUT	314	314	471	628	785	942	1099
		IN	235	235	352	470	587	705	822
32	16	OUT	804	804	1206	1608	2010	2412	2814
		IN	603	603	904	1206	1507	1809	2110
40	16	OUT	1256	1256	1884	2512	3140	3768	4396
		IN	1055	1055	1582	2110	2637	3165	3692
50	20	OUT	1963	1963	2944	3926	4907	5889	6870
		IN	1649	1649	2473	3298	4122	4947	5771
63	20	OUT	3117	3117	4675	6234	7792	9351	10909
		IN	2803	2803	4204	5606	7007	8409	9810
80	25	OUT	5026	5026	7539	10052	12565	15078	17591
		IN	4535	4535	6802	9070	11337	13605	15872
100	30	OUT	7853	7853	11779	15706	19632	23559	27485
		IN	7147	7147	10720	14294	17867	21441	25014

Theoretical output (N) = Pressure (MPa) x Piston area (mm²)

Weight

Unit: g

Bore size (mm)	Cylinder stroke (mm)										Male thread additional weight		
	5	10	15	20	25	30	35	40	45	50		75	100
20	180	200	220	240	260	280	300	320	340	360	—	—	10
32	330	350	370	390	410	430	450	470	490	510	610	710	52
40	480	500	520	540	560	580	600	620	640	660	760	860	52
50	—	860	890	920	950	980	1010	1040	1070	1100	1250	1400	100
63	—	1250	1290	1330	1370	1410	1450	1490	1530	1570	1770	1970	100
80	—	2380	2470	2560	2650	2740	2830	2920	3010	3100	3550	4000	172
100	—	3520	3630	3740	3850	3960	4070	4180	4290	4400	4950	5500	283

⚠ Specific Product Precautions

Be sure to read this before handling the products.

Refer to back page 50 for Safety Instructions and pages 214 to 221 for Hydraulic Cylinder and Auto Switch Precautions.

Usage

⚠ Caution

- Use hexagon socket head cap screws (JISB1176, strength class 10.9 or higher) for cylinder mounting. (ø20: 2 pcs.; ø32 to ø100: 4 pcs.)
- Since a lateral load (eccentric load) cannot be applied to the piston rod, build the mounting jig in such a way that a lateral load will not be applied to the piston rod.
- Make sure that the interlocking length of the rod end thread (male or female thread) and the mounting material is at least 80% of the thread diameter.

- When operating a cylinder for the first time, be sure to release the air inside the cylinder and the piping. When the air release is complete, operate the cylinder at reduced pressure, then gradually increase it to the normal operating pressure.
- Since CH□QB series does not have an air release plug, release air from other components (e.g. from piping, etc.) as well.
- When mounting the cylinder body with mounting bolts, use the tightening torques in the table at right as a guide.

Body mounting bolt tightening torques

Bore size (mm)	Mounting bolt		Tightening torque N·m
	Size	Qty.	
20	M5 x 0.8	2	3
32	M5 x 0.8	4	3
40	M5 x 0.8	4	3
50	M6 x 1	4	6
63	M8 x 1.25	4	11.5
80	M10 x 1.5	4	24
100	M10 x 1.5	4	34

- Do not use two cylinders facing one another horizontally or vertically in such a way that their piston rods strike each other.
- When the cylinder head side contains hydraulic fluid or is in a normally pressurized condition, the applied load must not be allowed to strike the piston rod end. Avoid such applications.

Mounting Bolts for CH□QB

Mounting: Through hole type mounting bolts are available.
 Refer to the following for ordering procedures.
 Order the actual number of bolts that will be used.

Example) CQ-M5x55L 4 pcs.

Mounting bolt diagram

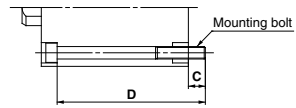

Model	C	D	Mounting bolt part no.	Model	C	D	Mounting bolt part no.			
CH□QB20-5D (M)	7	55	CQ-M5 x 55L	CH□QB63-10D (M)	15.5	95	CQ-M8 x 95L			
-10D (M)		60	x 60L	-15D (M)		100	x 100L			
-15D (M)		65	x 65L	-20D (M)		105	x 105L			
-20D (M)		70	x 70L	-25D (M)		110	x 110L			
-25D (M)		75	x 75L	-30D (M)		115	x 115L			
-30D (M)		80	x 80L	-35D (M)		120	x 120L			
-35D (M)		85	x 85L	-40D (M)		125	x 125L			
-40D (M)		90	x 90L	-45D (M)		130	x 130L			
-45D (M)		95	x 95L	-50D (M)		135	x 135L			
-50D (M)		100	x 100L	-75D (M)		160	x 160L			
CH□QB32-5D (M)	7	70	CQ-M5 x 70L	-100D (M)	185	x 185L	CH□QB80-10D (M)	14.5	100	CQ-M10 x 100L
-10D (M)		75	x 75L	-15D (M)	105	x 105L				
-15D (M)		80	x 80L	-20D (M)	110	x 110L				
-20D (M)		85	x 85L	-25D (M)	115	x 115L				
-25D (M)		90	x 90L	-30D (M)	120	x 120L				
-30D (M)		95	x 95L	-35D (M)	125	x 125L				
-35D (M)		100	x 100L	-40D (M)	130	x 130L				
-40D (M)		105	x 105L	-45D (M)	135	x 135L				
-45D (M)		110	x 110L	-50D (M)	140	x 140L				
-50D (M)		115	x 115L	-75D (M)	165	x 165L				
-75D (M)	140	x 140L	-100D (M)	190	x 190L					
-100D (M)	165	x 165L	CH□QB100-10D (M)	13.5	105	CQ-M10 x 105L				
CH□QB40-5D (M)	10	75	CQ-M5 x 75L		-15D (M)	110	x 110L			
-10D (M)		80	x 80L		-20D (M)	115	x 115L			
-15D (M)		85	x 85L		-25D (M)	120	x 120L			
-20D (M)		90	x 90L		-30D (M)	125	x 125L			
-25D (M)		95	x 95L		-35D (M)	130	x 130L			
-30D (M)		100	x 100L		-40D (M)	135	x 135L			
-35D (M)		105	x 105L		-45D (M)	140	x 140L			
-40D (M)		110	x 110L		-50D (M)	145	x 145L			
-45D (M)		115	x 115L		-75D (M)	170	x 170L			
-50D (M)		120	x 120L	-100 (M)	195	x 195L				
-75D (M)	145	x 145L								
-100D (M)	170	x 170L								
CH□QB50-10D (M)	12	90	CQ-M6 x 90L							
-15D (M)		95	x 95L							
-20D (M)		100	x 100L							
-25D (M)		105	x 105L							
-30D (M)		110	x 110L							
-35D (M)		115	x 115L							
-40D (M)		120	x 120L							
-45D (M)		125	x 125L							
-50D (M)		130	x 130L							
-75D (M)		155	x 155L							
-100D (M)	180	x 180L								

- CHQ**
- CH□
- CHN**
- CHM**
- CHS□
- CH2□
- CHA**
- Related Products
- D-□

CH□QB Series

Construction

CH□QB20

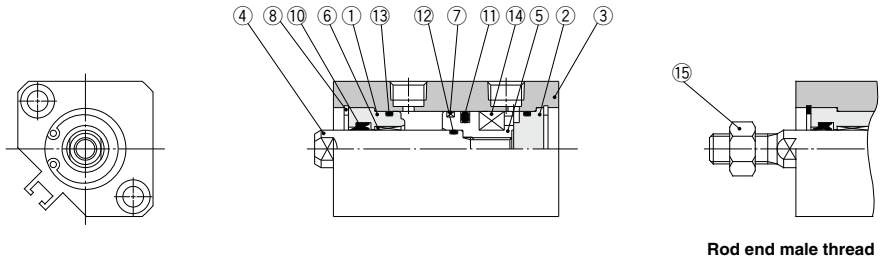

Rod end male thread

CH□QB32 to CH□QB100

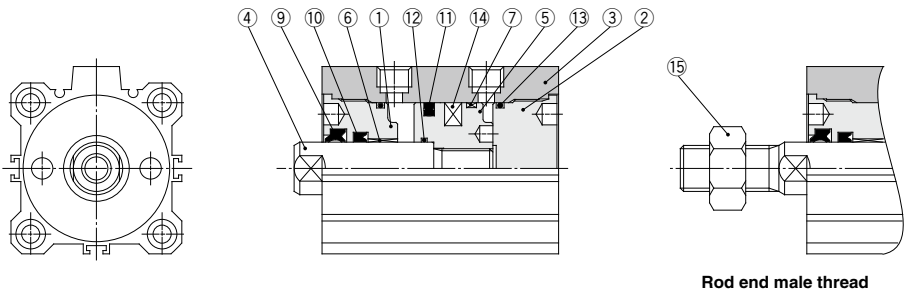

Rod end male thread

Parts List

No.	Description	Material	Note
1	Rod cover	Aluminum alloy	Black anodized
2	Head cover	Aluminum alloy	Black anodized
3	Cylinder tube	Aluminum alloy	Hard anodized
4	Piston rod	ø20: Stainless steel ø32 to ø100: Carbon steel	Hard chromium electroplated
5	Piston	Aluminum alloy	Chromated
6	Bushing	Copper alloy	
7	Wear ring	Resin	
8	Retaining ring (ø20 only)	Carbon tool steel	Black zinc chromated
9	Scraper	NBR	
10	Rod seal	NBR	
11	Piston seal	NBR	
12	Piston gasket	NBR	
13	Tube gasket	NBR	
14	Magnet	—	
15	Rod end nut	Carbon steel	Nickel plated

Replacement Parts: Seal Kit

Bore size (mm)	Seal kit no.	Content
20	CHQ20-PS	Nos. ⑨, ⑩, ⑪ and ⑬ from the chart at left
32	CHQ32-PS	
40	CHQ40-PS	
50	CHQ50-PS	
63	CHQ63-PS	
80	CHQ80-PS	
100	CHQ100-PS	

* Seal kit consists of items ⑨, ⑩, ⑪ and ⑬ and can be ordered by using the seal kit number for each bore size.

* Special tool required for disassembly. Contact SMC for recommended tool designs and dimensions.

Dimensions

ø20

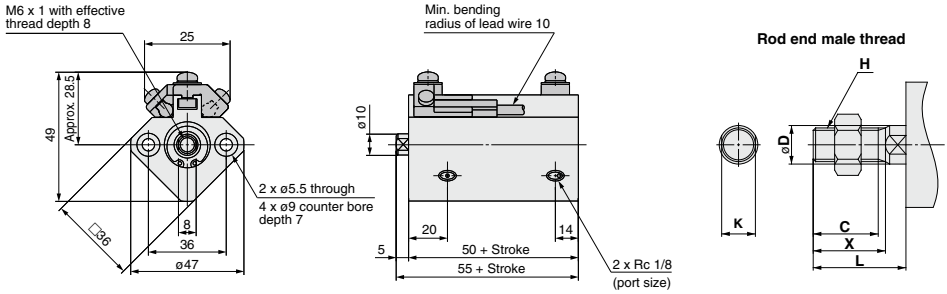

ø32 to ø100

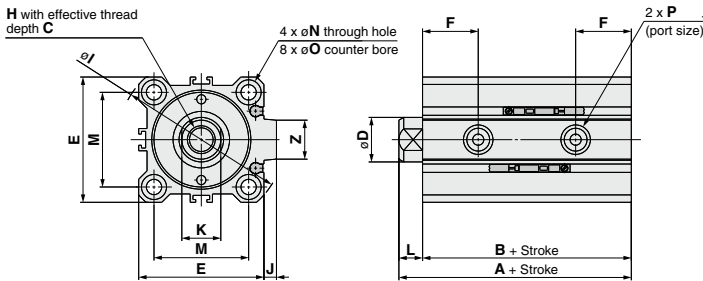

Note) The auto switches above are shown for a D-M9□(W) solid state auto switch.

Bore size (mm)	A	B	C	D	E	F	H	I	J	K	L	M	N	O	P	S	U	Z
32	73.5	65	12	16	45	20	M10 x 1.5	60	4.5	14	8.5	34	5.5	9 depth 7	Rc1/8	58.5	31.5	14
40	75.5	67	12	16	52	22	M10 x 1.5	69	5	14	8.5	40	5.5	9 depth 7	Rc1/8	66	35	14
50	87	76	15	20	64	25	M12 x 1.75	86	7	18	11	50	6.6	11 depth 8	Rc1/4	80	41	19
63	91	80	15	20	77	27	M12 x 1.75	103	7	18	11	60	9	14 depth 10.5	Rc1/4	93	47.5	19
80	100	89	20	25	98	28	M16 x 2	132	6	22	11	77	11	17.5 depth 13.5	Rc3/8	112.5	57.5	26
100	107	95	24	30	117	29	M20 x 2.5	156	6.5	26	12	94	11	17.5 depth 13.5	Rc3/8	132.5	67.5	26

Rod end male threads

Bore size (mm)	C	X	D	H	L	K
20	15.5	18	10	M8 x 1.25	23	8
32	27	30	16	M14 x 1.5	38.5	14
40	27	30	16	M14 x 1.5	38.5	14
50	32	35	20	M18 x 1.5	46	18
63	32	35	20	M18 x 1.5	46	18
80	37	40	25	M22 x 1.5	51	22
100	37	40	30	M26 x 1.5	52	26

Accessory (Standard)

Rod end nut

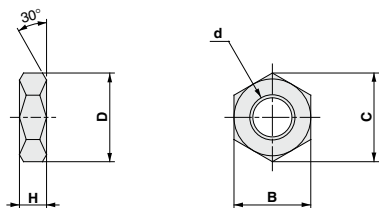

Material: Carbon steel

Part no.	Bore size (mm)	B	C	d	D	H
NT-02	20	13	15	M8 x 1.25	12.5	5
NT-04	32	22	25.4	M14 x 1.5	21	8
NT-04	40	22	25.4	M14 x 1.5	21	8
NT-05	50	27	31.2	M18 x 1.5	26	11
NT-05	63	27	31.2	M18 x 1.5	26	11
NT-08	80	32	37	M22 x 1.5	31	13
NT-10	100	41	47.3	M26 x 1.5	39	16



1 Intermediate Strokes (Using Exclusive Body)

Symbol

-XB10

CH □ QB Bore size - Stroke D □ - XB10

Rod end thread type	
Nil	Female thread
M	Male thread

* Rod end nut is provided as standard for male thread type.

Intermediate stroke (Using exclusive body)

Specifications

Model	CH□QB
Action	Double acting/Single rod
Bore size (mm)	32, 40, 50, 63, 80, 100
Mounting	Through hole
Auto switch	Mountable
Other specifications	Same as standard double acting single rod

When using an intermediate stroke other than the compact hydraulic cylinder (CH□QB series) standard strokes, it is possible to shorten the overall length and reduce the mounting space by using an exclusive body that does not have spacers installed.

Dimensions

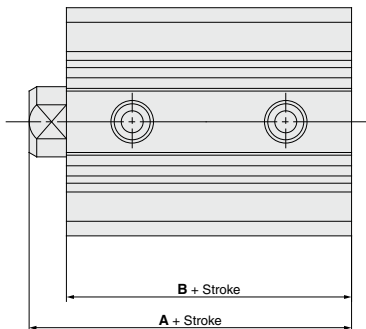

Bore size (mm)	(mm)	
	A	B
	55 to 100 mm strokes	55 to 100 mm strokes
32	73.5	65
40	75.5	67
50	87	76
63	91	80
80	100	89
100	107	95

* Dimensions other than the above are the same as the standard double acting single rod type.

Note) Applicable strokes are available in 5 mm increments.

CHQ

CHK□

CHN

CHM

CHS□

CH2□

CHA

Related Products

D-□

Compact Hydraulic Cylinder Double Acting/Double Rod

CH□QWB Series

3.5 MPa

∅20, ∅32, ∅40, ∅50, ∅63, ∅80, ∅100

How to Order

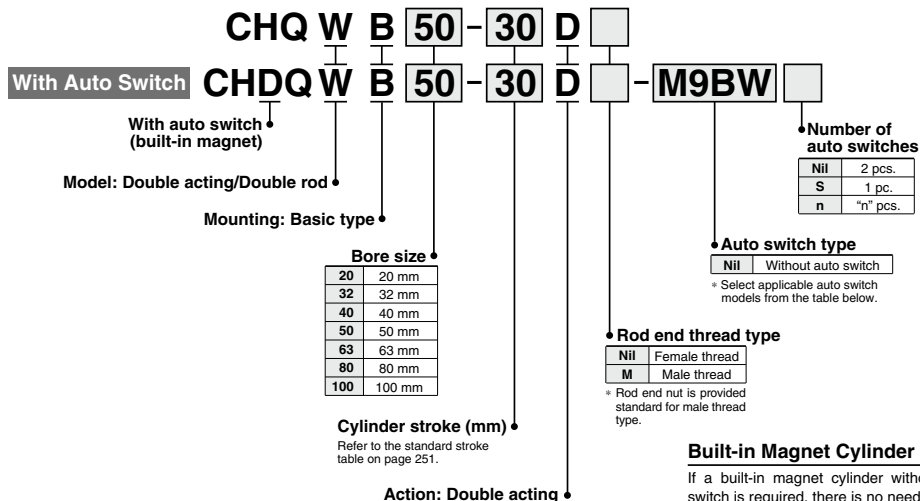

Built-in Magnet Cylinder Model

If a built-in magnet cylinder without auto switch is required, there is no need to enter the symbol for the auto switch.
(Example) CHDQWB50-100D

Applicable Auto Switches

Refer to pages 431 to 490 for further details on each auto switch.

Type	Special function	Electrical entry	Indicator light	Wiring (output)	Load voltage		Auto switch model		Lead wire length (m)					Pre-wired connector	Applicable load
					DC	AC	Perpendicular	In-line	0.5 (Nil)	1 (M)	3 (L)	5 (Z)	None (N)		
Solid state auto switch	—	Grommet	Yes	3-wire (NPN)	5 V, 12 V	—	M9NV	M9N	●	●	●	○	—	—	IC circuit
				3-wire (PNP)			M9PV	M9P	●	●	●	○	—		
		2-wire		M9BV	M9B	●	●	●	○	—	—	—			
		—		J79C	—	●	●	●	●	—	—				
	Diagnostic indication (2-color indicator)	Grommet	Yes	3-wire (NPN)	5 V, 12 V	—	M9NVV	M9NV	●	●	●	○	—	—	IC circuit
				3-wire (PNP)			M9PVV	M9PV	●	●	●	○	—		
		2-wire		M9BWW	M9BW	●	●	●	○	—	—	—			
		3-wire (NPN)		M9NAV ^{*1}	M9NA ^{*1}	○	○	●	○	—	—				
Water resistant (2-color indicator)	Grommet	Yes	3-wire (PNP)	5 V, 12 V	—	M9PAV ^{*1}	M9PA ^{*1}	○	○	●	○	—	—	IC circuit	
			2-wire			M9BAV ^{*1}	M9BA ^{*1}	○	○	○	○	—	—		
	4-wire		—	F79F	●	●	●	○	—	—	IC circuit				
	Diagnostic output (2-color indicator)		—	A96V	●	—	●	—	—	—					
Reed auto switch	—	Grommet	Yes	2-wire (NPN equiv.)	5 V	—	A96V	A96	●	—	●	—	—	—	—
				—	200 V	A72	A72H	●	—	●	—	—			
		—		12 V	100 V	A93V ^{*2}	A93	●	●	●	●	—	—		
		—		5 V, 12 V	100 V or less	A90V	A90	●	—	●	—	—			
	Diagnostic indication (2-color indicator)	Connector	No	Yes	2-wire	24 V	—	A73C	—	●	—	●	●	—	IC circuit
				No	5 V, 12 V	24 V or less	A80C	—	●	—	●	●	—		
		Grommet		Yes	—	—	—	A79W	—	●	—	●	—	—	—
					—	—	—	—	—	●	—	●	—	—	

*1 Water resistant type auto switches can be mounted on the above models, but in such case SMC cannot guarantee water resistance.

Consult with SMC regarding water resistant types with the above model numbers.

*2 1 m type lead wire is only applicable to D-A93.

* Lead wire length symbols: 0.5 m Nil (Example) M9NV
1 m M (Example) M9NVW
3 m L (Example) M9NVWL
5 m Z (Example) M9NVWZ
None N (Example) J79CN

* Solid state auto switches marked "□" are produced upon receipt of order.

* Since there are applicable auto switches other than listed, refer to page 258 for details.

* For details about auto switches with pre-wired connector, refer to pages 474 and 475.

* For mounting D-A9□(V), M9□(V), M9□(V), M9□(A)(V) with ∅2 to ∅50 to a surface other than the port surface, order an auto switch mounting bracket separately.

Refer to page 259 for details.

Compact Hydraulic Cylinder **CH□QWB Series**

Double Acting/Double Rod: 3.5 MPa

Specifications



Double acting/Double rod

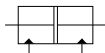

Bore size (mm)	20	32	40	50	63	80	100
Action	Double acting/Double rod						
Fluid	Hydraulic fluid						
Nominal pressure	3.5 MPa						
Proof pressure	5.0 MPa						
Maximum allowable pressure	3.5 MPa						
Minimum operating pressure	0.3 MPa						
Ambient and fluid temperature	Without auto switch: -10° to 80°C						
	With auto switch: -10° to 60°C						
Piston speed	8 to 100 mm/s						
Cushion	None						
Rod end thread	Standard: Female thread, Male thread						
Stroke length tolerance	+1.0 0 mm						
Mounting type	Basic type						
Mounting	Through hole						

Note) Refer to page 214 for definitions of terms related to pressure.

CHQ

CHK□

CHN

CHM

CHS□

CH2□

CHA

Related
Products

D-□

Hydraulic Fluid Compatibility

Hydraulic fluid	Compatibility
Standard mineral hydraulic fluid	Compatible
W/O hydraulic fluid	Compatible
O/W hydraulic fluid	Compatible
Water/Glycol hydraulic fluid	Not compatible
Phosphate hydraulic fluid	Not compatible

Standard Strokes

Bore size (mm)	Standard strokes (mm)
20	5, 10, 15, 20, 25, 30, 35, 40, 45, 50
32	5, 10, 15, 20, 25, 30, 35, 40, 45, 50, 75, 100
40	5, 10, 15, 20, 25, 30, 35, 40, 45, 50, 75, 100
50	10, 15, 20, 25, 30, 35, 40, 45, 50, 75, 100
63	10, 15, 20, 25, 30, 35, 40, 45, 50, 75, 100
80	10, 15, 20, 25, 30, 35, 40, 45, 50, 75, 100
100	10, 15, 20, 25, 30, 35, 40, 45, 50, 75, 100

Note) Consult with SMC regarding the manufacture of strokes other than the above.

Theoretical Output

Unit: N

Bore size (mm)	Rod size (mm)	Piston area (mm ²)	Operating pressure (MPa)					
			1.0	1.5	2.0	2.5	3.0	3.5
20	10	235	235	352	470	587	705	822
32	16	603	603	904	1206	1507	1809	2110
40	16	1055	1055	1582	2110	2637	3165	3692
50	20	1649	1649	2473	3298	4122	4947	5771
63	20	2803	2803	4204	5606	7007	8409	9810
80	25	4535	4535	6802	9070	11337	13605	15872
100	30	7147	7147	10720	14294	17867	21441	25014

Theoretical output (N) = Pressure (MPa) x Piston area (mm²)

Weight

Unit: g

Bore size (mm)	Cylinder stroke (mm)											Male thread additional weight	
	5	10	15	20	25	30	35	40	45	50	75		100
20	205	230	255	280	305	330	355	380	405	430	—	—	20
32	410	445	480	515	550	585	620	655	690	725	900	1075	104
40	570	605	640	675	710	745	780	815	850	885	1060	1235	104
50	—	1030	1080	1130	1180	1230	1280	1330	1380	1430	1680	1930	200
63	—	1430	1485	1540	1595	1650	1705	1760	1815	1870	2145	2420	200
80	—	2680	2805	2930	3055	3180	3305	3430	3555	3680	4305	4930	344
100	—	4075	4235	4395	4555	4715	4875	5035	5195	5355	6155	6955	566

⚠ Specific Product Precautions

- Be sure to read this before handling the products.
Refer to back page 50 for Safety Instructions and pages 214 to 221 for Hydraulic Cylinder and Auto Switch Precautions.

Usage

⚠ Caution

- Use hexagon socket head cap screws (JISB1176, strength class 10.9 or higher) for cylinder mounting. (ø20: 2pcs, ø32 to ø100: 4pcs.)
- Since a lateral load (eccentric load) cannot be applied to the piston rod, build your mounting jig in such a way that a lateral load will not be applied to the piston rod.
- Make sure that the interlocking length of the rod end threads (male or female thread) and the mounting material is at least 80% of the thread diameter.
- Be sure to release the air inside the cylinder and the piping before operating the cylinder for the first time. When the air release is complete, operate the cylinder at reduced pressure, then gradually increase it to the normal operating pressure.

- Since CH□QWB series does not have an air release plug, release air from components other than the cylinder (e.g. from piping, etc.) as well.
- When mounting the cylinder body with mounting bolts, use tightening torques in the table below as a guide.

Body mounting bolt tightening torques

Bore size (mm)	Mounting bolt		Tightening torque N·m
	Size	No.	
20	M5 x 0.8	2	3
32	M5 x 0.8	4	3
40	M5 x 0.8	4	3
50	M6 x 1	4	6
63	M8 x 1.25	4	11.5
80	M10 x 1.5	4	24
100	M10 x 1.5	4	34

- When tightening the piston rod end threads, be sure to use the wrench flats of the rod on the side where the threads are being tightened. Use care, as damage may occur if rotational force is applied to both ends of the piston rod.
- Do not use two cylinders facing one another horizontally or vertically in such a way that their piston rods strike each other.
- When the cylinder head contains fluid or is in a normally pressurized condition, the load should not be allowed to strike the piston rod end. Avoid such applications.

Mounting Bolts for CH□QWB

Mounting: Through hole type mounting bolts are available.
 Refer to the following for ordering procedures.
 Order the actual number of bolts that will be used.

Example) CQ-M5x65L 4 pcs.

Mounting bolt diagram

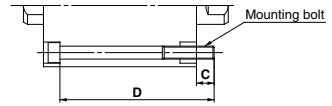

Mounting Bolts

Model	C	D	Mounting bolt part no.	Model	C	D	Mounting bolt part no.			
CH□QWB20-5D (M)	10	65	CQ-M5 x 65L	CH□QWB63-10D (M)	15.5	95	CQ-M8 x 95L			
-10D (M)		70	x 70L	-15D (M)		100	x 100L			
-15D (M)		75	x 75L	-20D (M)		105	x 105L			
-20D (M)		80	x 80L	-25D (M)		110	x 110L			
-25D (M)		85	x 85L	-30D (M)		115	x 115L			
-30D (M)		90	x 90L	-35D (M)		120	x 120L			
-35D (M)		95	x 95L	-40D (M)		125	x 125L			
-40D (M)		100	x 100L	-45D (M)		130	x 130L			
-45D (M)		105	x 105L	-50D (M)		135	x 135L			
-50D (M)		110	x 110L	-75D (M)		160	x 160L			
CH□QWB32-5D (M)	7	70	CQ-M5 x 70L	-100D (M)	185	x 185L	CH□QWB80-10D (M)	14.5	100	CQ-M10 x 100L
-10D (M)		75	x 75L	-15D (M)	105	x 105L				
-15D (M)		80	x 80L	-20D (M)	110	x 110L				
-20D (M)		85	x 85L	-25D (M)	115	x 115L				
-25D (M)		90	x 90L	-30D (M)	120	x 120L				
-30D (M)		95	x 95L	-35D (M)	125	x 125L				
-35D (M)		100	x 100L	-40D (M)	130	x 130L				
-40D (M)		105	x 105L	-45D (M)	135	x 135L				
-45D (M)		110	x 110L	-50D (M)	140	x 140L				
-50D (M)		115	x 115L	-75D (M)	165	x 165L				
-75D (M)	140	x 140L	-100D (M)	190	x 190L	CH□QWB100-10D (M)	13.5	105	CQ-M10 x 105L	
-100D (M)	165	x 165L	-15D (M)	110	x 110L					
CH□QWB40-5D (M)	10	75	CQ-M5 x 75L	-20D (M)	115	x 115L				
-10D (M)		80	x 80L	-25D (M)	120	x 120L				
-15D (M)		85	x 85L	-30D (M)	125	x 125L				
-20D (M)		90	x 90L	-35D (M)	130	x 130L				
-25D (M)		95	x 95L	-40D (M)	135	x 135L				
-30D (M)		100	x 100L	-45D (M)	140	x 140L				
-35D (M)		105	x 105L	-50D (M)	145	x 145L				
-40D (M)		110	x 110L	-75D (M)	170	x 170L				
-45D (M)		115	x 115L	-100D (M)	195	x 195L	CH□QWB50-10D (M)	12	90	CQ-M6 x 90L
-50D (M)		120	x 120L	-15D (M)	95	x 95L				
-75D (M)	145	x 145L	-20D (M)	100	x 100L					
-100D (M)	170	x 170L	-25D (M)	105	x 105L					
CH□QWB50-10D (M)	12	90	CQ-M6 x 90L	-30D (M)	110	x 110L				
-15D (M)		95	x 95L	-35D (M)	115	x 115L				
-20D (M)		100	x 100L	-40D (M)	120	x 120L				
-25D (M)		105	x 105L	-45D (M)	125	x 125L				
-30D (M)		110	x 110L	-50D (M)	130	x 130L				
-35D (M)		115	x 115L	-75D (M)	155	x 155L				
-40D (M)		120	x 120L	-100D (M)	180	x 180L				
-45D (M)		125	x 125L							
-50D (M)		130	x 130L							
-75D (M)		155	x 155L							
-100D (M)	180	x 180L								

- CHQ**
- CHK□
- CHN**
- CHM
- CHS□
- CH2□
- CHA**
- Related Products
- D-□

CH□QWB Series

Construction

CH□QWB20

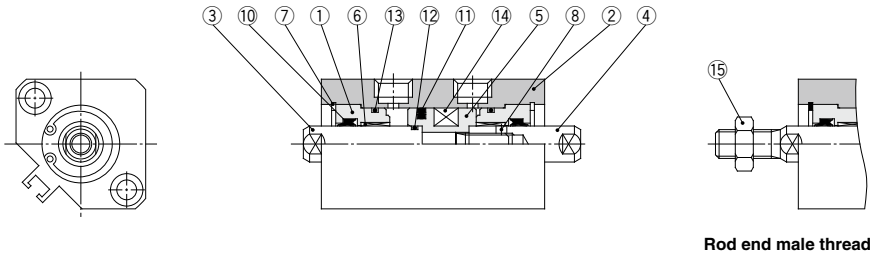

CH□QWB32 to CH□QWB100

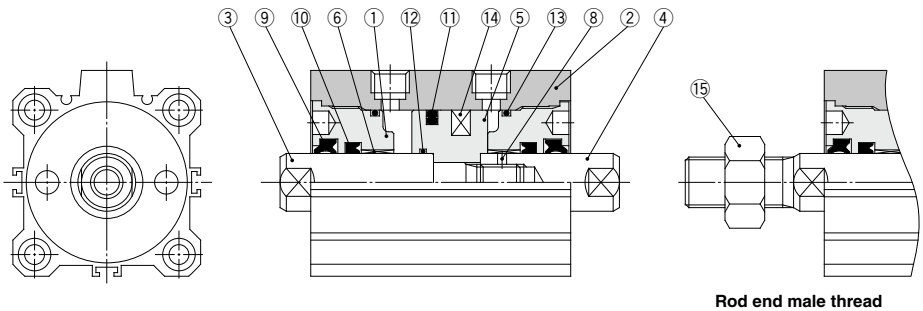

Parts List

No.	Description	Material	Note
1	Rod cover	Aluminum alloy	Black anodized
2	Cylinder tube	Aluminum alloy	Hard anodized
3	Piston rod A	ø20: Stainless steel ø32 to ø100: Carbon steel	Hard chromium electroplated
4	Piston rod B	ø20: Stainless steel ø32 to ø100: Carbon steel	Hard chromium electroplated
5	Piston	Aluminum alloy	Chromated
6	Bushing	Copper alloy	
7	Retaining ring (ø20 only)	Carbon tool steel	Black zinc chromated
8	Spring pin		
9	Scraper	NBR	
10	Rod seal	NBR	
11	Piston seal	NBR	
12	Piston gasket	NBR	
13	Tube gasket	NBR	
14	Magnet	—	
15	Rod end nut	Carbon steel	Nickel plated

Replacement Parts: Seal Kit

Bore size (mm)	Seal kit no.	Content
20	CHQW20-PS	Nos. ⑨, ⑩, ⑪ and ⑬ from the chart at left
32	CHQW32-PS	
40	CHQW40-PS	
50	CHQW50-PS	
63	CHQW63-PS	
80	CHQW80-PS	
100	CHQW100-PS	

* Seal kit consists of items ⑨, ⑩, ⑪ and ⑬ and can be ordered by using the seal kit number for each bore size.

* Special tool required for disassembly. Contact SMC for recommended tool designs and dimensions.

Compact Hydraulic Cylinder **CH□QWB Series**

Double Acting/Double Rod: 3.5 MPa

Dimensions

ø20

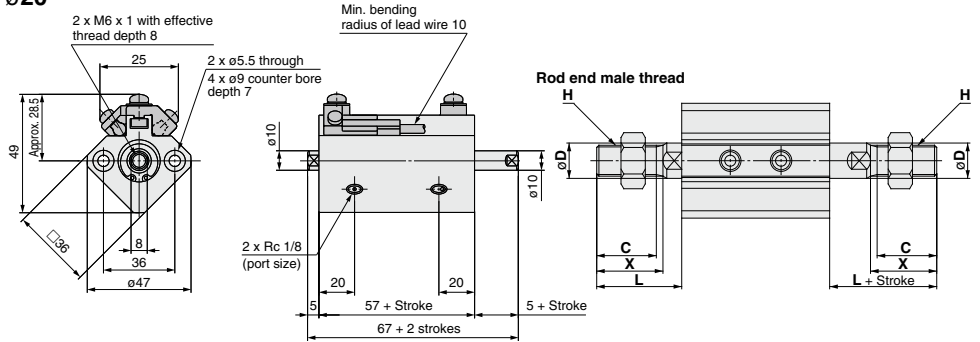

ø32 to ø100

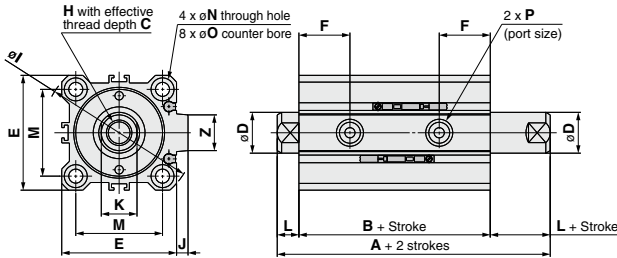

Note) The auto switches above are shown for a D-M9□(W) solid state auto switch.

Bore size (mm)	A	B	C	D	E	F	H	I	J	K	L	M	N	O	P	S	U	Z
32	82	65	12	16	45	20	M10 x 1.5	60	4.5	14	8.5	34	5.5	9 depth 7	Rc1/8	58.5	31.5	14
40	84	67	12	16	52	22	M10 x 1.5	69	5	14	8.5	40	5.5	9 depth 7	Rc1/8	66	35	14
50	98	76	15	20	64	25	M12 x 1.75	86	7	18	11	50	6.6	11 depth 8	Rc1/4	80	41	19
63	102	80	15	20	77	27	M12 x 1.75	103	7	18	11	60	9	14 depth 10.5	Rc1/4	93	47.5	19
80	111	89	20	25	98	28	M16 x 2	132	6	22	11	77	11	17.5 depth 13.5	Rc3/8	112.5	57.5	26
100	119	95	24	30	117	29	M20 x 2.5	156	6.5	26	12	94	11	17.5 depth 13.5	Rc3/8	132.5	67.5	26

Rod end male threads

Bore size (mm)	C	X	D	H	L	K
20	15.5	18	10	M8 x 1.25	23	8
32	27	30	16	M14 x 1.5	38.5	14
40	27	30	16	M14 x 1.5	38.5	14
50	32	35	20	M18 x 1.5	46	18
63	32	35	20	M18 x 1.5	46	18
80	37	40	25	M22 x 1.5	51	22
100	37	40	30	M26 x 1.5	52	26

CHQ

CHK□

CHN

CHM

CHS□

CH2□

CHA

Related Products

D-□

Accessory (Standard)

Rod end nut

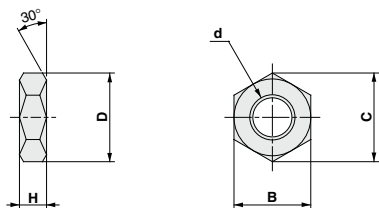

Material: Carbon steel

Part no.	Bore size (mm)	B	C	d	D	H
NT-02	20	13	15	M8 x 1.25	12.5	5
NT-04	32	22	25.4	M14 x 1.5	21	8
NT-04	40	22	25.4	M14 x 1.5	21	8
NT-05	50	27	31.2	M18 x 1.5	26	11
NT-05	63	27	31.2	M18 x 1.5	26	11
NT-08	80	32	37	M22 x 1.5	31	13
NT-10	100	41	47.3	M26 x 1.5	39	16

CH□QB/CH□QWB Series Auto Switch Mounting

Refer to pages 431 to 490 for detailed specifications.

Auto Switches: Proper Mounting Positions and Mounting Heights for Stroke End Detection

D-M9□
D-M9□W
D-M9□AL
D-A9□

D-M9□V
D-M9□WV
D-M9□AV
D-A9□V

ø20

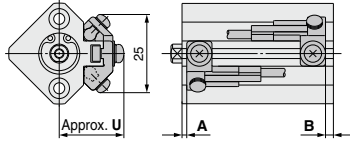

ø32 to ø100

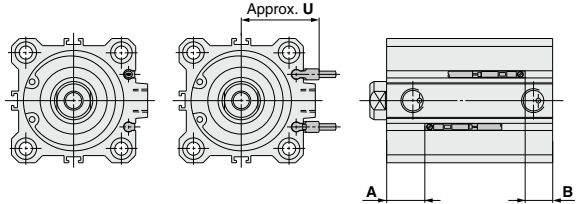

D-F7□
D-F7□W
D-J79
D-J79W
D-A7□
D-A7□H
D-A8□
D-A8□H

D-F7□V
D-F7□WV
D-F7BA
D-F7BAV
D-F7NT
D-F79F
D-J79C
D-A73C
D-A80C

ø32 to ø100

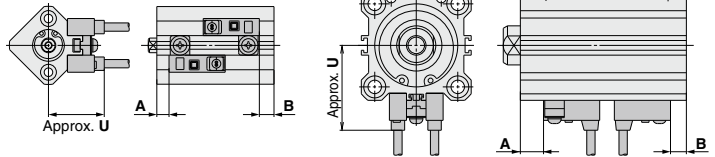

Auto Switch Proper Mounting Positions

(mm)

Bore size (mm)	Solid state auto switch						Reed auto switch							
	D-M9□/M9□V D-M9□W/M9□WV D-M9□A/M9□AV		D-F7□/J79 D-F7□V/J79C D-F7□W/F7□WV D-F7BA/F7BAV D-F79F/J79W		D-F7NT		D-A9□/A9□V		D-A73/A80		D-A7□H/A80H D-A73C/A80C D-A72		D-A79W	
	A	B	A	B	A	B	A	B	A	B	A	B	A	B
20	24.5	10.5	23.5	9.5	28.5	14.5	20.5	6.5	23	9	23.5	9.5	20.5	6.5
32	30	23	27.5	20.5	32.5	25.5	26	19	27	20	27.5	20.5	24.5	17.5
40	29	26	26.5	23.5	31.5	28.5	25	22	26	23	26.5	23.5	23.5	20.5
50	36.5	27.5	34	25	39	30	32.5	23.5	33.5	24.5	34	25	31	22
63	36.5	31.5	34	29	39	34	32.5	27.5	33.5	28.5	34	29	31	26
80	44	33	41.5	30.5	46.5	35.5	40	29	41	30	41.5	30.5	38.5	27.5
100	47.5	35.5	45	33	50	38	43.5	31.5	44.5	32.5	45	33	42	30

Note) Adjust the auto switch after confirming the operating conditions in the actual setting.

Auto Switch Mounting Heights

(mm)

Bore size (mm)	D-M9□ D-M9□W D-M9□A D-A9□	D-M9□V D-M9□WV D-M9□AV	D-A9□V	D-A7□ D-A80	D-F7□ D-F7□W D-J79 D-J79W D-F7BA D-F7BAV D-F7NT D-F79F D-A7□H D-A80H	D-A73C D-A80C	D-F7□V D-F7□WV D-F7BAV	D-J79C	D-A79W
	U	U	U	U	U	U	U	U	U
20	26.5	26.5	26.5	24.5	25.5	31.5	28	31	27
32	24.5	29	27	31.5	32.5	38.5	35	38	34
40	28	32.5	30.5	35	36	42	38.5	41.5	37.5
50	34	38.5	36.5	41	42	48	44.5	47.5	43.5
63	37.5	42	40	47.5	48.5	54.5	51	54	50
80	47.5	52	50	57.5	58.5	64.5	61	64	60
100	57.5	62	60	67.5	68.5	74.5	71	74	70

CH□QB/CH□QWB Series

Minimum Auto Switch Mounting Stroke

(mm)						
Auto switch mounting number	D-M9□ D-M9□V D-F7□V D-J79C	D-A9□ D-A9□V D-A7□ D-A80 D-A7□H D-A80H D-A73C D-A80C	D-F7□ D-J79	D-M9□WV D-M9□AV D-F7□W D-F7□WV D-J79W D-F7BAV	D-M9□W D-M9□A D-F7BAL D-F7NT D-F79F	D-A79W
1 pc.	5	5	10(5)	10	15(10)	15
2 pcs.	5	10	10	15	15	20

Note) The dimension stated in () shows the minimum stroke for the auto switch mounting when the auto switch does not project from the end surface of the cylinder body and hinder the lead wire bending space. (Refer to the figure below.)
The auto switch and auto switch mounting bracket are ordered separately.

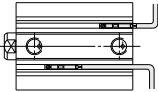

Operating Range

Auto switch model	Bore size						
	20	32	40	50	63	80	100
D-M9□/M9□V D-M9□W/M9□WV D-M9□A/M9□AV	5.5	6.5	6	6.5	6	7	7.5
D-F7□/J79 D-F7□V/J79C D-F7□W/F7□WV D-F7BA/F7BAV D-F79F/J79W/F7NT	5.5	6	5.5	6	6.5	6.5	6.5
D-A9□/A9□V	9	9	9	8.5	10.5	10	10.5
D-A7□/A80 D-A7□H/A80H D-A73C/A80C	11.5	11.5	11.5	11.5	13.5	12.5	14
D-A79W	15	15	15	15	17	16	17.5

* Since this is a guideline including hysteresis, not meant to be guaranteed. (Assuming approximately ±30% dispersion.)
There may be the case it will vary substantially depending on an ambient environment.

Besides the models listed in "How to Order," the following auto switches are applicable.
Refer to pages 431 to 490 for detailed auto switch specifications.

Auto switch type	Part no.	Electrical entry	Features
Solid state	D-F7NV, F7PV, F7BV	Grommet (perpendicular)	—
	D-F7NWV, F7BWV		Diagnostic indication (2-color indicator)
	D-F7BAV		Water resistant (2-color indicator)
	D-F79, F7P, J79	Grommet (in-line)	—
	D-F79W, F7PW, J79W		Diagnostic indication (2-color indicator)
	D-F7BA		Water resistant (2-color indicator)
	D-F7NT		With timer
Reed	D-A73	Grommet (perpendicular)	—
	D-A80		Without indicator light
	D-A73H, A76H	Grommet (in-line)	—
	D-A80H		Without indicator light

* Solid state switches are also available with pre-wired connector. Refer to pages 474 and 475 for details.

* Normally closed (N.C. = b contact), solid state auto switches (D-F9G, F9H) are also available. For details, refer to page 443.

Auto Switch Mounting Brackets: Part Nos.

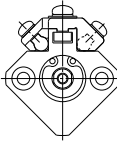
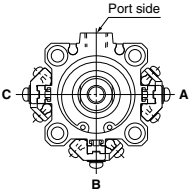
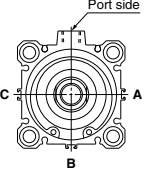
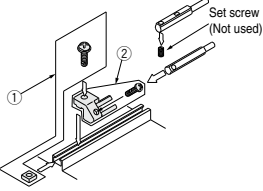
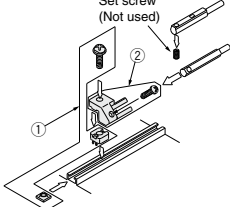
Auto switch mounting surface	Bore size (mm)		
	φ20	φ32, φ40, φ50	φ63, φ80, φ100
			
	Auto switch mounting surface	Auto switch mounting surface	Auto switch mounting surface
Auto switch models	Auto switch mounting rail surface only	Port side A, B, C	Port, A, B, C sides
	<p>① BQ-1 ② BQ2-012 Two types of auto switch mounting bracket are used as a set.</p> 	<p>① BQ-2 ② BQ2-012 Two types of auto switch mounting bracket are used as a set.</p>  <p style="text-align: center;">Auto switch mounting bracket not required.</p>	<p style="text-align: center;">Auto switch mounting bracket not required.</p>
<p>D-M9□ D-M9□V D-M9□W D-M9□WV D-M9□A D-M9□AV D-A9□ D-A9□V</p>			

Note 1) To mount a compact auto switch on either of the three sides (A, B, and C above) other than the port side, mounting brackets are required separately other than the auto switch mounting brackets in the table above, so please order them separately from the cylinder.

(This is the same for when mounting a compact auto switch using an auto switch mounting rail, instead of using a compact auto switch mounting groove for φ63 to φ100.)

Example

CHDQB32-50-M9NW.....1 unit

BQ-2.....2 pcs.

BQ2-012.....2 pcs.

Note 2) Auto switch mounting brackets and auto switches are packed together at cylinder shipment.

Auto switch models	Bore size (mm)	
	φ20	φ32 to φ100
<p>D-F7□J79 D-F7□V D-J79C D-F7□W/J79W D-F7□WV D-F7BAL/F7BAV D-F79F/F7NT D-A7□A80 D-A73C/A80C D-A7□H/A80H D-A79W</p>	BQ-1	BQ-2

Note 3) Auto switch mounting brackets and auto switches are packed together at cylinder shipment.

[Stainless steel mounting screw kits]

The following stainless mounting screw kits (including nuts) are available for use depending on the operating environment. (Auto switch spacers (for BQ-2) are not included. Please order BQ-2 separately.)

BBA2: For D-A7/A8/F7/J7 types

When D-F7BA and F7BAV auto switches are shipped mounted on a cylinder, the above stainless steel screws are used. Also when switches are shipped separately, BBA2 is included.

Note 4) Refer to the table below for details on BBA2.

Note 5) When an additional D-M9□A(V) is required, order stainless steel screw kit BBA2 or BQ2-012S as a set separately.

Stainless mounting screw kit details

Part no.	No.	Description	Contents		Applicable auto switch mounting bracket part nos.	Applicable auto switches
			Size	Pcs.		
BBA2	1	Auto switch mounting screws	M3 x 0.5 x 6L	1	BMU-1-025	D-A7/A8 D-F7/J7
			M3 x 0.5 x 8L	1	BQ-1	
			M3 x 0.5 x 10L	1	BQ-2	
	2	Auto switch mounting nuts (square nut)	M3 x 0.5	1	BQ-1	
	3	Auto switch mounting nuts (convex)	M3 x 0.5	1	BQ-2	

Note 6) Spacers (black resin) for BQ-2 are not included.

Note 7) Also when using BQ2-012 with D-A9□(V)/M9□(V)/M9□W(V), or M9□A(V) auto switches, use stainless steel screws equivalent to the auto switch mounting brackets appropriate for each cylinder series.

Weight of auto switch mounting bracket

Mounting bracket part no.	Applicable cylinder I.D.	Weight (g)
BQ-1	φ20	1.5
BQ-2	φ32 to φ100	1.5
BQ2-012	φ20	5

CHQ

CHK□

CHN

CHM

CHS□

CH2□

CHA

Related Products

D-□

CH□QB/CH□QWB Series

How to Mount and Move the Auto Switch

<Applicable auto switch>

Solid state D-M9N(V), D-M9P(V), D-M9B(V)
 D-M9NW(V), D-M9PW(V), D-M9BW(V)
 D-M9NA(V), D-M9PA(V), D-M9BA(V)
 Reed D-A90(V), A93(V), A96(V)

ø20

1. Insert the square nut for BQ-1 in the auto switch mounting rail and set it at the approximate auto switch mounting position.
2. Fit the convex part of the auto switch mounting bracket arm over the concave part of the rail, and slide the arm to the nut position.
3. Push the auto switch mounting screw (M3 for BQ-1) lightly into the square nut through the hole of the auto switch mounting arm.
4. Remove the set screw (M2.5) attached to the auto switch.
5. Insert the auto switch in the auto switch attachment part of the auto switch mounting bracket.
6. Secure the auto switch mounting screw (M2.5). (Tightening torque of M2.5 screw: 0.1 to 0.2 N·m)
7. Secure the auto switch mounting screw (3) after confirming the detecting position. (Tightening torque of M3 screw: 0.5 to 0.7 N·m)
8. Modify the detecting position while the auto switch is secured at the position of (3) in the figure.

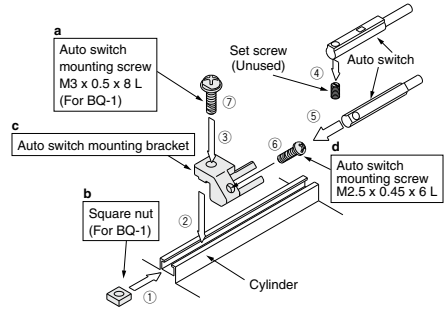

- BQ-1 and BMU1-025 are a set of a and b shown above.
- BQ2-012 is a set of c and d shown above.

ø32 to ø100

1. Insert the square nut for BQ-2 in the auto switch mounting rail and set it at the approximate auto switch mounting position.
2. Fit the protruding part of the auto switch mounting spacer over the concave part of the rail, and slide the spacer to the nut position.
3. Fit the convex part of the auto switch mounting bracket arm over the concave part of the switch spacer.
4. Turn the auto switch mounting screw (M3 for BQ-2) lightly into the square nut through the mounting holes of the auto switch mounting arm and switch spacer.
5. Remove the set screw (M2.5) attached to the auto switch.
6. Insert the auto switch in the auto switch attachment part of the auto switch mounting bracket.
7. Secure the auto switch mounting screw (M2.5). (Tightening torque of M2.5 screw: 0.1 to 0.2 N·m)
8. Secure the auto switch mounting screw (4) after confirming the detecting position. (Tightening torque of M3 screw: 0.5 to 0.7 N·m)
9. Modify the detecting position while the auto switch is secured at the position of (4) in the figure.

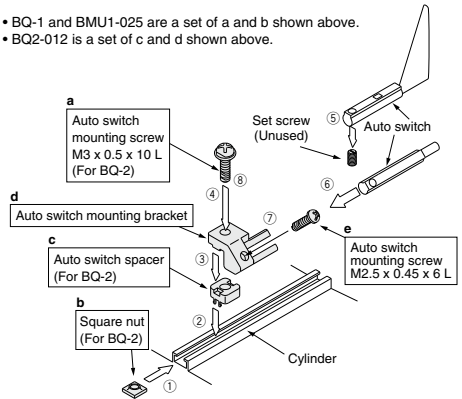

- BQ-2 is a set of a, b and c shown above.
- BQ2-012 is a set of d and e shown above.

ø32 to ø100

- When tightening an auto switch mounting screw, use a watchmaker's screwdriver with a grip diameter of 5 to 6 mm.

Tightening torque for

auto switch mounting screw (N·m)

Auto switch model	Tightening torque
D-A9□(V)	0.10 to 0.20
D-M9□(V)	0.05 to 0.15
D-M9□W(V)	

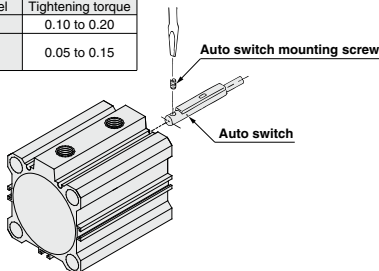

<Applicable auto switch>

- Solid state** D-F79, D-F7P, D-J79, D-F7NV
 D-F7PV, D-F7BV, D-J79C
 D-F79W, D-F7PW, D-J79W
 D-F7NWV, D-F7BWV
 D-F79F, D-F7BA, D-F7BAV
 D-F7NT
- Reed** D-A72, D-A73, D-A80, D-A72H
 D-A73H, D-A76H, D-A80H
 D-A73C, D-A80C, D-A79W

1. Slide the auto switch mounting nut inserted into the mounting rail and set it at the auto switch mounting position.
2. Fit the convex part of auto switch mounting arm into the concave part of auto switch mounting rail. Then slide the switch over the nut.
 (CDQ2 series: Fit the convex part of auto switch mounting arm through the auto switch spacer into the concave part of auto switch mounting rail.)
3. Push the auto switch mounting screw lightly into the mounting nut through the hole of auto switch mounting arm.
4. After reconfirming the detecting position, tighten the mounting screw to secure the auto switch.
 (Tightening torque of M3 screw should be 0.5 to 0.7 N·m.)
5. Modification of the detecting position should be made in the condition of 3.

∅20

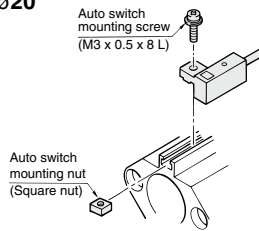

∅32 to ∅100

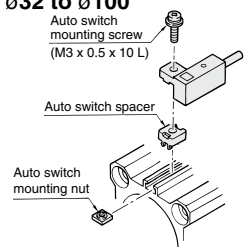

CHQ
CHK□
CHN
CHM
CHS□
CH2□
CHA
Related Products
D-□