

Compact Cylinder/Guide Rod Type

Series CQM

ø12, ø16, ø20, ø25, ø32, ø40, ø50, ø63, ø80, ø100

How to Order

Without auto switch

CQM B 20 10

With auto switch

CDQM B 20 10 M9B S

With auto switch

Mounting

B	Through-hole (Standard)
A	Both ends tapped (ø32 to ø100)

Note 1) Cylinder bodies of ø12 to ø25 are common for both B (through hole) and A (both ends tapped) types. Symbol to order is unified to "B" for those sizes.
Note 2) Contact SMC for the other mounting types.

Number of auto switches

-	2 pcs.
S	1 pc.
n	"n" pcs.

Auto switch type

-	Without auto switch (Built-in magnet cylinder)
---	--

* Refer to the table below for auto switch model numbers.

* Auto switches are packed together when shipped (unassembled). (Except for D-P5DWL)

Bore size

12	12mm	40	40mm
16	16mm	50	50mm
20	20mm	63	63mm
25	25mm	80	80mm
32	32mm	100	100mm

Port thread type

-	M thread	ø12 to ø25
-	Rc	
TN	NPT	ø32 to ø100
TF	G	

Note 3) M thread to be used for without auto switch type of ø32, 5 stroke exceptionally.

Cylinder stroke (mm)

Refer to the next page for standard and intermediate strokes.

Applicable Auto Switches/Refer to Best Pneumatics for detailed auto switch specifications.

Type	Special function	Electrical entry	Indicator/light	Wiring (output)	Load voltage			Rail mounting		Direct mounting		Lead wire length (m)*				Applicable load		
					DC		AC	ø32 to ø100		ø12 to ø100		0.5 (Nil)	3 (L)	5 (Z)	None (N)			
								Perpendicular	In-line	Perpendicular	In-line							
Reed switch	-	Grommet	Yes	3-wire (NPN equiv.)	-	5 V	-	-	A76H	A96V	A96	●	●	-	-	IC circuit	-	
					-	-	200 V	A72	A72H	-	-	●	●	-	-	-	-	
					2-wire	24 V	100 V	12 V	A73	A73H	-	-	●	●	●	-	-	-
								5 V, 12 V	A80	A80H	A90V	A90	●	●	-	-	IC circuit	Relay, PLC
								12 V	-	-	A93V	A93	●	●	-	-	-	
								12 V	A73C	-	-	-	●	●	●	●	-	
					Connector	No	-	5 V, 12 V	A80C	-	-	-	●	●	●	●	-	IC circuit
5 V, 12 V	A79W	-	-	-				●	●	-	-	-						
Diagnostic indication (2-colour display)	Grommet	Yes	-	A79W	-	-	-	●	●	-	-	-	-					
Solid state switch	-	Grommet	Yes	3-wire (NPN)	24 V	5 V, 12 V	-	F7NV	F79	M9NV	M9N	●	●	○	-	IC circuit	Relay, PLC	
				3-wire (PNP)				F7PV	F7P	M9PV	M9P	●	●	○	-			
				2-wire				F7BV	J79	M9BV	M9B	●	●	○	-			
				2-wire				J79C	-	-	-	●	●	●	●	-		
				3-wire (NPN)				F7NWW	F79W	M9NWW	M9NW	●	●	○	-			
		Connector	No	-	3-wire (PNP)	5 V, 12 V	-	F7PW	M9PW	M9PW	●	●	○	-	IC circuit			
					3-wire (PNP)	5 V, 12 V	-	F7BWW	J79W	M9BWW	M9BW	●	●	○	-			
					2-wire	12 V	-	F7BAV	-	-	-	●	○	-				
					2-wire	12 V	-	-	-	-	-	●	○	-				
					5 V, 12 V	-	P5DW	-	-	-	-	●	●	-				

* Lead wire length symbols: 0.5 m..... Nil (Example) A73C
3 m..... L A73CL
5 m..... Z A73CZ
None..... N A73CN

* Solid state switches marked with a "○" symbol are produced upon receipt of order.

- In addition to the models in the above table, there are some other auto switches that are applicable. For more information, please refer to page 12.
- D-P5DWL type: ø40 to ø100 only available.

Made to Order Specifications → Refer to Best Pneumatics.

- -50 Without indicator light
- -61 Flexible lead wire
- Pre-wired connector

Compact Cylinder/Guide Rod Type **Series CQM**



⚠ Caution

- ① Do not use the product as a stopper.
- ② Do not disassemble and modify the product.

Specifications

Model	Pneumatic (non-lube) type	
Action	Double acting, Single rod	
Fluid	Air	
Proof pressure	1.5 MPa	
Maximum operating pressure	1.0 MPa	
Minimum operating pressure	ø12, ø16	0.12 MPa
	ø20 to ø100	0.1 MPa
Ambient and fluid temperature	Without auto switch: -10°C to 70°C (with no freezing) With auto switch: -10°C to 60°C (with no freezing)	
Cushion	Rubber bumper on both ends	
Stroke length tolerance	+1.0 mm 0	
Mounting	Through-holes	
Piston speed	ø12 to ø40	50 to 500 mm/s
	ø50 to ø100	50 to 300 mm/s

Standard Stroke

Bore size (mm)	Standard stroke (mm)
12,16	5, 10, 15, 20, 25, 30
20,25	5, 10, 15, 20, 25, 30, 35, 40, 45, 50
32,40	5, 10, 15, 20, 25, 30, 35, 40, 45, 50, 75, 100
50,63,80,100	10, 15, 20, 25, 30, 35, 40, 45, 50, 75, 100

Manufacture of Intermediate Stroke

Description		Intermediate stroke range	
Spacers are installed in a cylinder with standard stroke.		Bore size (mm)	Intermediate stroke range (mm)
		12, 16	1 to 29
		20, 25	1 to 49
		32	1 to 99
		40 to 100	5 to 95
Bore size (mm)	Description		
12 to 32	Available in 1 mm stroke increments		
40 to 100	Available in 5 mm stroke increments		

Example) Part number: CQMB32-57

Constructed by installing an 18 mm spacer in the standard stroke cylinder CQMB32-75. B dimension: 108 mm.

Theoretical Output

Unit: N

Bore size (mm)	Operating direction	Operating pressure (MPa)		
		0.3	0.5	0.7
12	IN	25	42	59
	OUT	34	57	79
16	IN	45	75	106
	OUT	60	101	141
20	IN	71	118	165
	OUT	94	157	220
25	IN	113	189	264
	OUT	147	245	344
32	IN	181	302	422
	OUT	241	402	563
40	IN	317	528	739
	OUT	377	628	880
50	IN	495	825	1150
	OUT	589	982	1370
63	IN	840	1400	1960
	OUT	936	1560	2184
80	IN	1362	2270	3178
	OUT	1509	2515	3521
100	IN	2145	3575	5005
	OUT	2355	3925	5495

Auto Switch Mounting Bracket Weight

Mounting bracket part no.	Applicable cylinder bore size	Weight (g)
BQ-2	ø32 to ø100	1.5
BQP1-050	ø40 to ø100	16

Weight

Without Auto Switch

Unit: g

Bore size (mm)	Cylinder stroke (mm)											
	5	10	15	20	25	30	35	40	45	50	75	100
12	44	52	60	69	77	86	—	—	—	—	—	—
16	56	67	77	87	97	108	—	—	—	—	—	—
20	92	107	122	137	152	167	183	198	213	227	—	—
25	125	143	162	180	198	216	234	252	270	288	—	—
32	182	205	228	250	274	297	320	343	366	389	553	669
40	269	295	320	345	370	396	421	446	471	497	692	823
50	—	500	540	580	620	661	701	740	780	821	1133	1341
63	—	745	795	845	894	944	993	1043	1093	1143	1535	1791
80	—	1400	1479	1559	1639	1719	1800	1880	1959	2039	2671	3067
100	—	2365	2468	2571	2674	2776	2880	2983	3086	3188	4053	4574

With Auto Switch (Built-in magnet)

Unit: g

Bore size (mm)	Cylinder stroke (mm)											
	5	10	15	20	25	30	35	40	45	50	75	100
12	52	59	68	77	84	93	—	—	—	—	—	—
16	66	77	87	97	107	118	—	—	—	—	—	—
20	122	138	153	168	182	197	213	227	242	257	—	—
25	168	186	205	223	240	258	277	295	313	331	—	—
32	241	264	287	309	333	356	379	401	425	448	564	680
40	345	371	396	421	447	473	498	523	548	574	705	836
50	—	618	658	698	738	779	819	858	898	939	1147	1355
63	—	903	953	1003	1052	1102	1152	1201	1251	1301	1557	1813
80	—	1661	1740	1820	1900	1980	2061	2141	2220	2300	2695	3090
100	—	2745	2848	2950	3053	3156	3260	3362	3465	3568	4088	4609

Add each weight of auto switches and mounting brackets.

Refer to pages 16 to 19 for auto switch weight.

Plate Non-rotating Accuracy

Non-rotating accuracy without load is designed to be same or less than the figures shown in the table below at the retracted cylinder end (plate).

Bore size (mm)	Non-rotating accuracy
12, 16	±0.2°
20 to 100	±0.1°

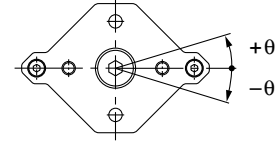
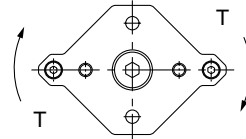

Plate Allowable Rotational Torque

Make sure to operate strictly within the allowable rotation torque range to the plate.

Operation outside of this range may result in shorter service life or damage to the device.



Unit: N·m

Bore size (mm)	Cylinder stroke (mm)											
	5	10	15	20	25	30	35	40	45	50	75	100
12	0.11	0.10	0.08	0.07	0.07	0.06	—	—	—	—	—	—
16	0.15	0.12	0.11	0.10	0.09	0.08	—	—	—	—	—	—
20	0.37	0.32	0.28	0.25	0.23	0.21	0.19	0.18	0.17	0.16	—	—
25	0.40	0.35	0.31	0.28	0.25	0.23	0.21	0.20	0.18	0.17	—	—
32	0.66	0.59	0.53	0.49	0.45	0.42	0.39	0.36	0.34	0.32	0.25	0.20
40	1.06	0.96	0.88	0.81	0.75	0.70	0.65	0.61	0.58	0.55	0.43	0.36
50	—	1.70	1.56	1.45	1.35	1.26	1.19	1.12	1.06	1.01	0.80	0.67
63	—	3.90	3.62	3.37	3.15	2.96	2.80	2.65	2.51	2.39	1.92	1.61
80	—	7.44	6.98	6.56	6.20	5.87	5.57	5.31	5.07	4.84	3.98	3.37
100	—	11.85	11.19	10.61	10.08	9.60	9.17	8.77	8.41	8.07	6.73	5.77

Plate Allowable Lateral Load

Make sure to operate strictly within the allowable lateral load range to the plate.

Operation outside of this range may result in shorter service life or damage to the device.

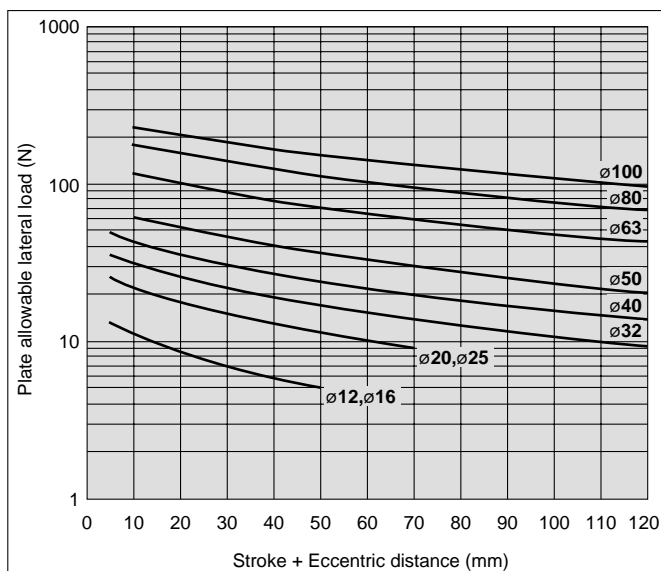
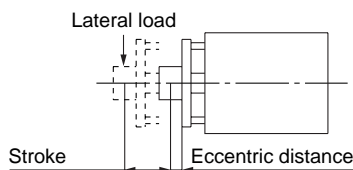

Allowable Kinetic Energy

Make sure to operate strictly within the allowable range of the load weight and maximum speed.

Operation outside of this range may cause excessive impact, which may result in the damage to the device.

Operating pressure: 0.5 MPa

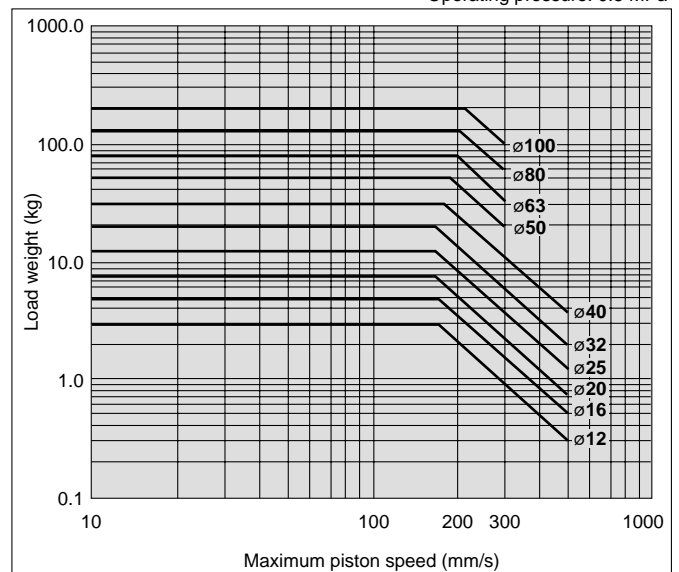

Construction

ø12 to ø25

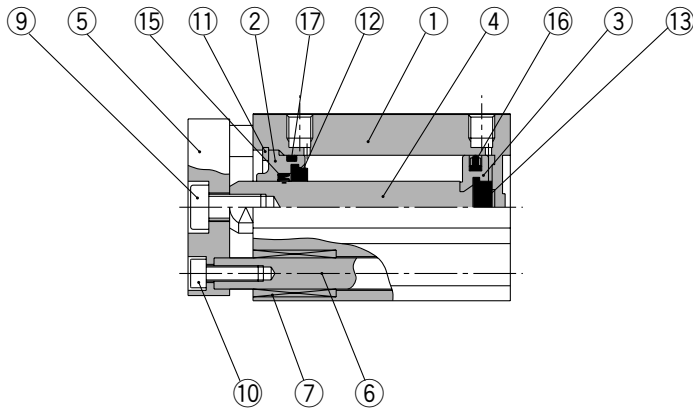

**With auto switch
(Built-in magnet)**

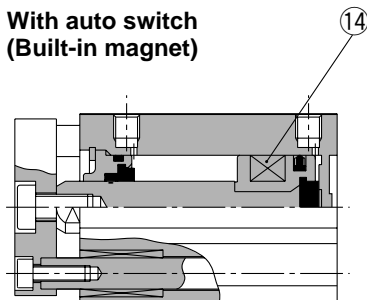

ø32 to ø100

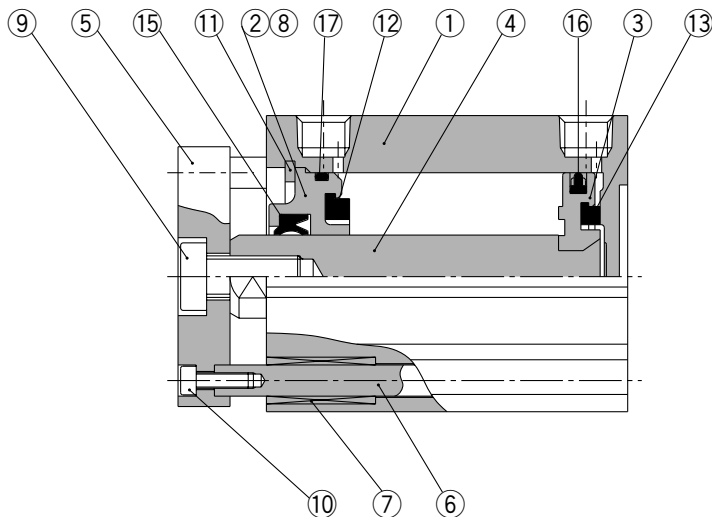

**With auto switch
(Built-in magnet)**

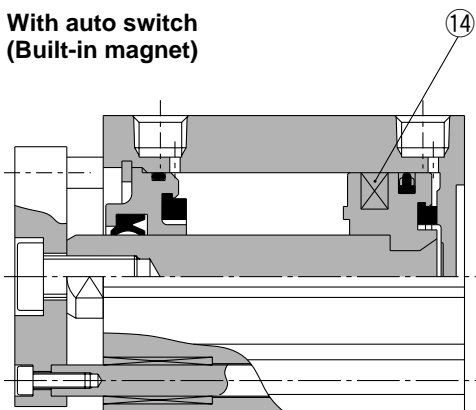

ø50 to ø100

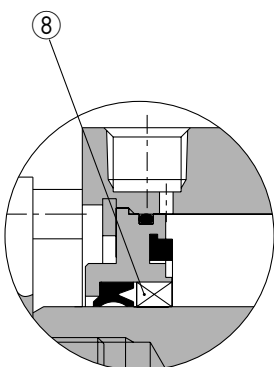

Component Parts

No.	Description	Material	Note
1	Cylinder tube	Aluminum alloy	Hard anodized
2	Collar	Aluminum alloy	ø12 to ø40 Anodized
		Aluminum alloy casted	ø50 to ø100 Chromated, Coated
3	Piston	Aluminum alloy	Chromated
4	Piston rod	Stainless steel	ø12 to ø25
		Carbon steel	ø32 to ø100 Hard chrome plated
5	Plate	Aluminum alloy	Anodized
6	Guide rod	Stainless steel	Hard chrome plated
7	Bushing	Oil-impregnated sintered alloy	
8	Bushing	Bronze alloy	ø50 to ø100
9	Hexagon socket head cap screw	Carbon steel	Nickel plated
10	Hexagon socket head cap screw	Carbon steel	Nickel plated
11	Snap ring	Carbon tool steel	Phosphate coated
12	Bumper A	Urethan	
13	Bumper B	Urethan	
14	Magnet	—	
15	Rod seal	NBR	
16	Piston seal	NBR	
17	Gasket	NBR	

Series CQM

Mounting Bolt

Mounting method: Mounting bolt for through-hole style of CQMB is available as an option.

Ordering: Add the word "Bolt" in front of the bolts to be used.

Example) Bolt M3 x 25ℓ 2 pcs.

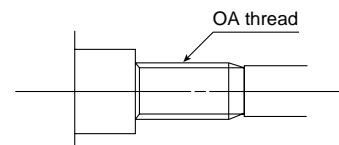
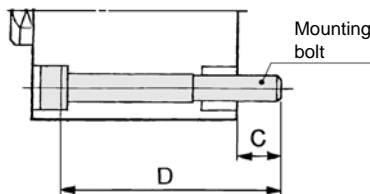

Note) To install a cylinder with bore size 12 to 25 mm with through-hole, be sure to use the attached flat washer.

Mounting Bolt for CQM/Without Auto Switch

Model	C	D	Mounting bolt
CQMB12- 5	6.5	25	M3 x 25ℓ
-10		30	x 30ℓ
-15		35	x 35ℓ
-20		40	x 40ℓ
-25		45	x 45ℓ
-30		50	x 50ℓ
CQMB16- 5	6.5	25	M3 x 25ℓ
-10		30	x 30ℓ
-15		35	x 35ℓ
-20		40	x 40ℓ
-25		45	x 45ℓ
-30		50	x 50ℓ
CQMB20- 5	6.5	25	M5 x 25ℓ
-10		30	x 30ℓ
-15		35	x 35ℓ
-20		40	x 40ℓ
-25		45	x 45ℓ
-30		50	x 50ℓ
-35		55	x 55ℓ
-40		60	x 60ℓ
-45		65	x 65ℓ
-50		70	x 70ℓ
CQMB25- 5		8.5	30
- 10	35		x 35ℓ
- 15	40		x 40ℓ
- 20	45		x 45ℓ
- 25	50		x 50ℓ
- 30	55		x 55ℓ
- 35	60		x 60ℓ
- 40	65		x 65ℓ
- 45	70		x 70ℓ
- 50	75		x 75ℓ

Model	C	D	Mounting bolt	
CQMB32- 5	9	30	M5 x 30ℓ	
- 10		35	x 35ℓ	
- 15		40	x 40ℓ	
- 20		45	x 45ℓ	
- 25		50	x 50ℓ	
- 30		55	x 55ℓ	
- 35		60	x 60ℓ	
- 40		65	x 65ℓ	
- 45		70	x 70ℓ	
- 50		75	x 75ℓ	
- 75	110	x 110ℓ		
-100	135	x 135ℓ		
CQMB40- 5	7.5	35	M5 x 35ℓ	
- 10		40	x 40ℓ	
- 15		45	x 45ℓ	
- 20		50	x 50ℓ	
- 25		55	x 55ℓ	
- 30		60	x 60ℓ	
- 35		65	x 65ℓ	
- 40		70	x 70ℓ	
- 45		75	x 75ℓ	
- 50		80	x 80ℓ	
- 75		115	x 115ℓ	
-100		140	x 140ℓ	
CQMB50- 10		12.5	45	M6 x 45ℓ
- 15			50	x 50ℓ
- 20	55		x 55ℓ	
- 25	60		x 60ℓ	
- 30	65		x 65ℓ	
- 35	70		x 70ℓ	
- 40	75		x 75ℓ	
- 45	80		x 80ℓ	
- 50	85		x 85ℓ	
- 75	120		x 120ℓ	
-100	145		x 145ℓ	

Model	C	D	Mounting bolt
CQMB63- 10	14.5	50	M8 x 50ℓ
- 15		55	x 55ℓ
- 20		60	x 60ℓ
- 25		65	x 65ℓ
- 30		70	x 70ℓ
- 35		75	x 75ℓ
- 40		80	x 80ℓ
- 45		85	x 85ℓ
- 50		90	x 90ℓ
- 75		125	x 125ℓ
-100	150	x 150ℓ	
CQMB80- 10	15	55	M10 x 55ℓ
- 15		60	x 60ℓ
- 20		65	x 65ℓ
- 25		70	x 70ℓ
- 30		75	x 75ℓ
- 35		80	x 80ℓ
- 40		85	x 85ℓ
- 45		90	x 90ℓ
- 50		95	x 95ℓ
- 75		130	x 130ℓ
-100	155	x 155ℓ	
CQMB100- 10	15.5	65	M10 x 65ℓ
- 15		70	x 70ℓ
- 20		75	x 75ℓ
- 25		80	x 80ℓ
- 30		85	x 85ℓ
- 35		90	x 90ℓ
- 40		95	x 95ℓ
- 45		100	x 100ℓ
- 50		105	x 105ℓ
- 75		140	x 140ℓ
-100	165	x 165ℓ	

Mounting Bolt for CDQM/With Auto Switch (Built-in magnet)

Model	C	D	Mounting bolt
CDQMB12- 5	6.5	30	M3 x 30ℓ
-10		35	x 35ℓ
-15		40	x 40ℓ
-20		45	x 45ℓ
-25		50	x 50ℓ
-30		55	x 55ℓ
CDQMB16- 5	6.5	30	M3 x 30ℓ
-10		35	x 35ℓ
-15		40	x 40ℓ
-20		45	x 45ℓ
-25		50	x 50ℓ
-30		55	x 55ℓ
CDQMB20- 5	6.5	35	M5 x 35ℓ
-10		40	x 40ℓ
-15		45	x 45ℓ
-20		50	x 50ℓ
-25		55	x 55ℓ
-30		60	x 60ℓ
-35		65	x 65ℓ
-40		70	x 70ℓ
-45		75	x 75ℓ
-50		80	x 80ℓ
CDQMB25- 5	8.5	40	M5 x 40ℓ
-10		45	x 45ℓ
-15		50	x 50ℓ
-20		55	x 55ℓ
-25		60	x 60ℓ
-30		65	x 65ℓ
-35		70	x 70ℓ
-40		75	x 75ℓ
-45		80	x 80ℓ
-50	85	x 85ℓ	

Model	C	D	Mounting bolt	
CDQMB32- 5	9	40	M5 x 40ℓ	
- 10		45	x 45ℓ	
- 15		50	x 50ℓ	
- 20		55	x 55ℓ	
- 25		60	x 60ℓ	
- 30		65	x 65ℓ	
- 35		70	x 70ℓ	
- 40		75	x 75ℓ	
- 45		80	x 80ℓ	
- 50		85	x 85ℓ	
- 75	110	x 110ℓ		
-100	135	x 135ℓ		
CDQMB40- 5	7.5	45	M5 x 45ℓ	
- 10		50	x 50ℓ	
- 15		55	x 55ℓ	
- 20		60	x 60ℓ	
- 25		65	x 65ℓ	
- 30		70	x 70ℓ	
- 35		75	x 75ℓ	
- 40		80	x 80ℓ	
- 45		85	x 85ℓ	
- 50		90	x 90ℓ	
- 75		115	x 115ℓ	
-100		140	x 140ℓ	
CDQMB50- 10		12.5	55	M6 x 55ℓ
- 15			60	x 60ℓ
- 20	65		x 65ℓ	
- 25	70		x 70ℓ	
- 30	75		x 75ℓ	
- 35	80		x 80ℓ	
- 40	85		x 85ℓ	
- 45	90		x 90ℓ	
- 50	95		x 95ℓ	
- 75	120		x 120ℓ	
-100	145	x 145ℓ		

Model	C	D	Mounting bolt
CDQMB63- 10	14.5	60	M8 x 60ℓ
- 15		65	x 65ℓ
- 20		70	x 70ℓ
- 25		75	x 75ℓ
- 30		80	x 80ℓ
- 35		85	x 85ℓ
- 40		90	x 90ℓ
- 45		95	x 95ℓ
- 50		100	x 100ℓ
- 75		125	x 125ℓ
-100	150	x 150ℓ	
CDQMB80- 10	15	65	M10 x 65ℓ
- 15		70	x 70ℓ
- 20		75	x 75ℓ
- 25		80	x 80ℓ
- 30		85	x 85ℓ
- 35		90	x 90ℓ
- 40		95	x 95ℓ
- 45		100	x 100ℓ
- 50		105	x 105ℓ
- 75		130	x 130ℓ
-100	155	x 155ℓ	
CDQMB100- 10	15.5	75	M10 x 75ℓ
- 15		80	x 80ℓ
- 20		85	x 85ℓ
- 25		90	x 90ℓ
- 30		95	x 95ℓ
- 35		100	x 100ℓ
- 40		105	x 105ℓ
- 45		110	x 110ℓ
- 50		115	x 115ℓ
- 75		140	x 140ℓ
-100	165	x 165ℓ	

Series CQM

Dimensions

ø12 to ø25

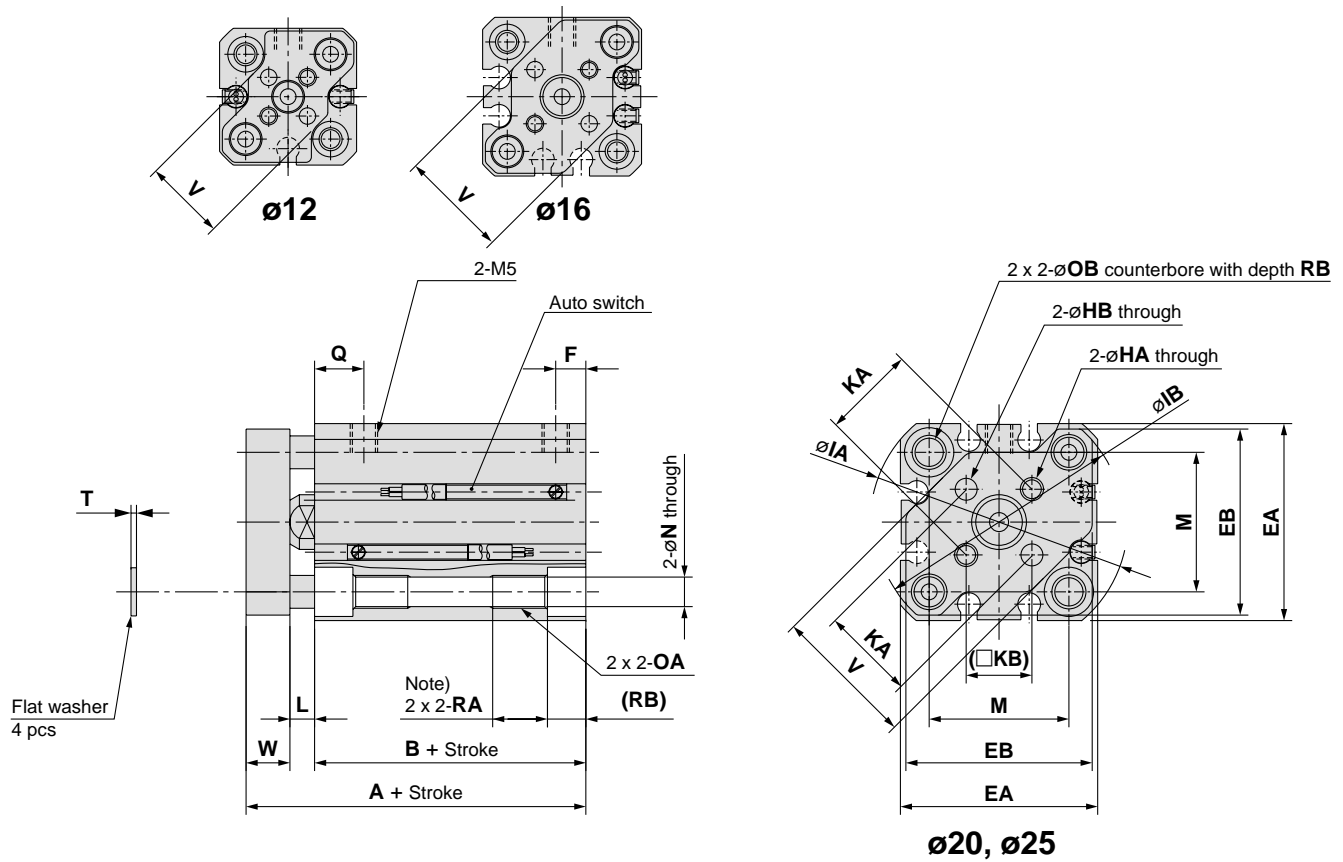

(mm)

Bore size (mm)	Stroke range (mm)	Without auto switch		With auto switch		EA	EB	F	HA	OA	HB	IA	IB
		A	B	A	B								
12	5 to 30	26.5	17	31.5	22	25	24	5	M3	M4	$3^{+0.2}_0$	32	31.5
16	5 to 30	26.5	17	31.5	22	29	28	5	M3	M4	$3^{+0.2}_0$	38	37
20	5 to 50	32	19.5	42	29.5	36	34	5.5	M4	M6	$4^{+0.2}_0$	47	45.5
25	5 to 50	35.5	22.5	45.5	32.5	40	38	5.5	M5	M6	$5^{+0.2}_0$	52	50.5

Bore size (mm)	KA	KB	L	M	N	OB	Q	RA	RB	T	V	W
12	10 ± 0.1	7.1	3.5	15.5	3.5	6.5	7.5	7	4	0.5	14.9	6
16	14 ± 0.1	9.9	3.5	20	3.5	6.5	7.5	7	4	0.5	20	6
20	17 ± 0.1	12	4.5	25.5	5.4	9	9	10	7	1	26	8
25	22 ± 0.1	15.6	5	28	5.4	9	11	10	7	1	30	8

Note) For the following bore/stroke sizes, the through-hole is threaded.

Standard without auto switch: ø12 and ø16; 5 stroke, ø20; 5 to 15 stroke, ø25; 5 and 10 stroke, ø20; 5 stroke

Built-in magnet with auto switch: ø20; 5 stroke

Dimensions

ø32 to ø50

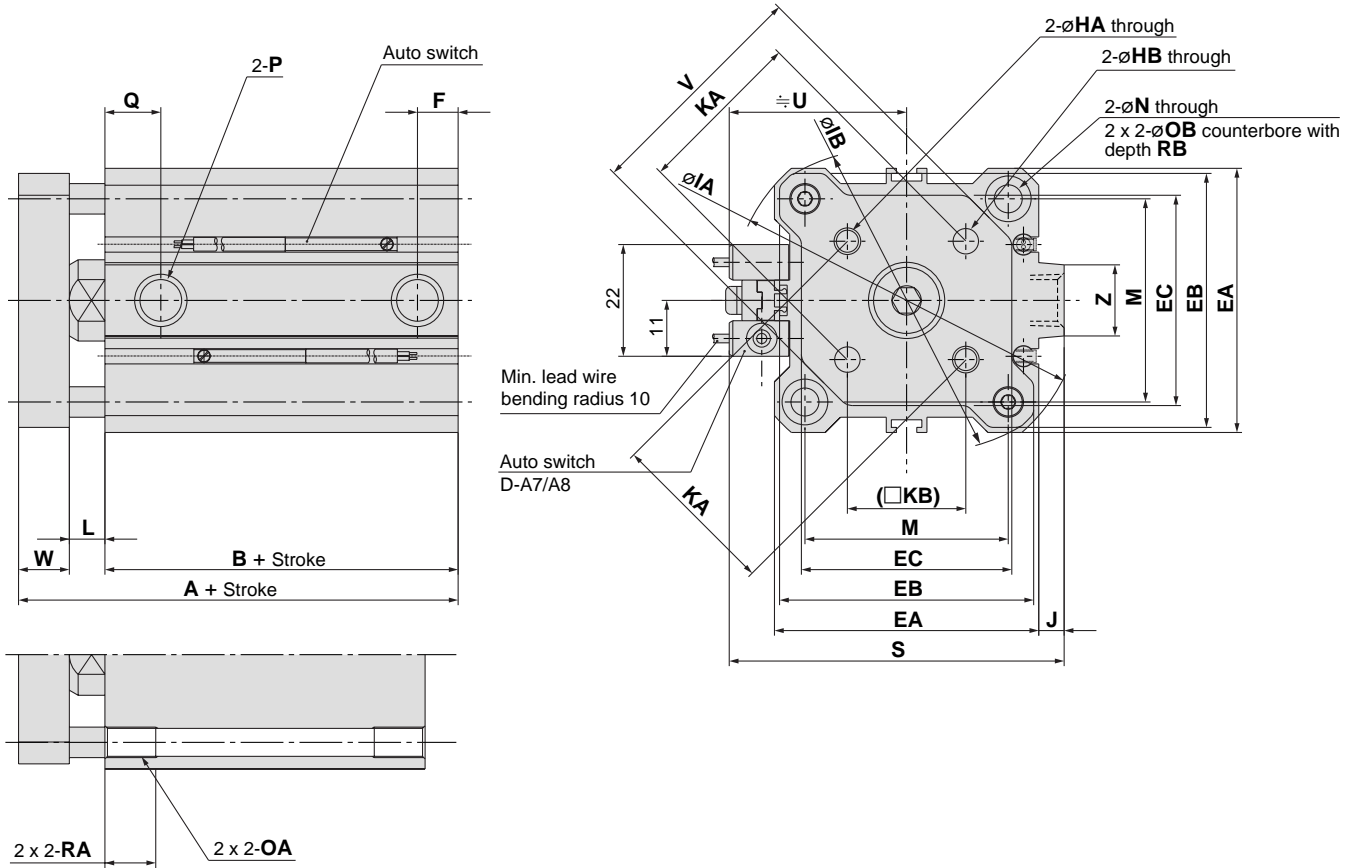

Both ends tapped (CQMA)

Bore size (mm)	Stroke range (mm)	Without auto switch							With auto switch							EA	EB	EC
		A	B	F	Q	P			A	B	F	Q	P					
						—	TN	TF					—	TN	TF			
32	5	40	23	5.5	11.5	M5	—	—	50	33	7.5	10.5	Rc1/8	NPT1/8	G1/8	45	43	34.4
	10 to 50			7.5	10.5	Rc1/8	NPT1/8	G1/8										
	75,100	50	33															
40	5 to 50	46.5	29.5	8	11	Rc1/8	NPT1/8	G1/8	56.5	39.5	8	11	Rc1/8	NPT1/8	G1/8	52	50	41.4
	75,100	56.5	39.5															
50	10 to 50	50.5	30.5	10.5	10.5	Rc1/4	NPT1/4	G1/4	60.5	40.5	10.5	10.5	Rc1/4	NPT1/4	G1/4	64	62	53.4
	75,100	60.5	40.5															

Bore size (mm)	HA	OA	HB	IA	IB	J	KA	KB	L	M	N	OB	RA	RB	S	U	V	W	Z
32	M5	M6	5 ^{+0.2} ₀	60	58.5	4.5	28 ± 0.2	19.8	7	34	5.5	9	10	7	58.5	31.5	38	10	14
40	M5	M6	5 ^{+0.2} ₀	69	67.5	5	33 ± 0.2	23.3	7	40	5.5	9	10	7	66	35	46	10	14
50	M6	M8	6 ^{+0.2} ₀	86	84.5	7	42 ± 0.2	29.7	8	50	6.6	11	14	8	80	41	58	12	19

Series CQM

Dimensions

ø63 to ø100

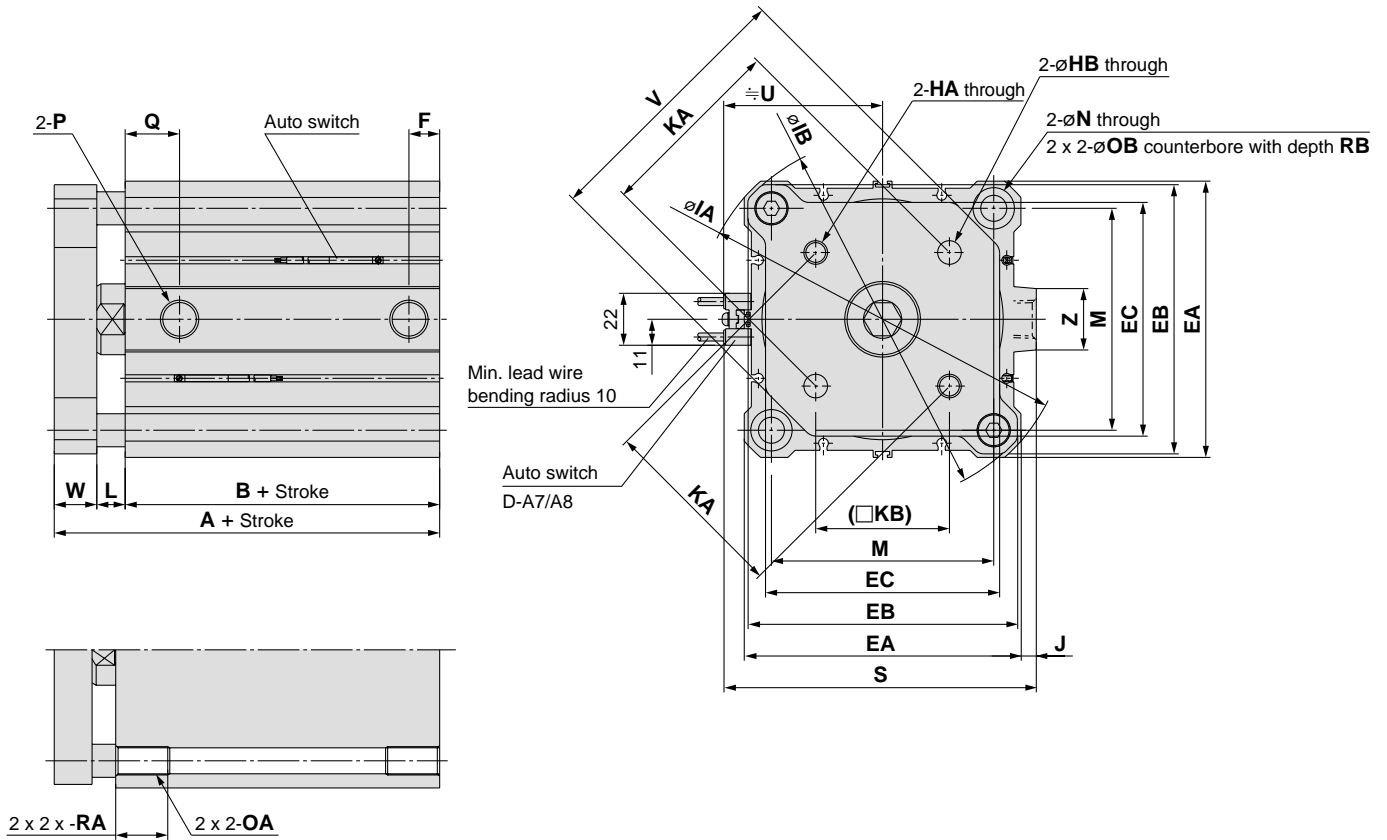

Both ends tapped (CQMA)

Bore size (mm)	Stroke range (mm)	Without auto switch		With auto switch		EA	EB	EC	F	HA	HB	IA	IB	J	KA	KB	L	M
		A	B	A	B													
63	10 to 50	56	36	66	46	77	74	59.6	10.5	M6	6 ^{+0.2} ₀	103	100	7	50 ± 0.2	35.4	8	60
	75,100	66	46															
80	10 to 50	67.5	43.5	77.5	53.5	98	95	79.5	12.5	M8	8 ^{+0.2} ₀	132	129	6	65 ± 0.2	46	10	77
	75,100	77.5	53.5															
100	10 to 50	79	53	89	63	117	114	99	13	M10	10 ^{+0.2} ₀	156	153	6.5	80 ± 0.2	56.6	10	94
	75,100	89	63															

Bore size (mm)	N	OA	OB	P			Q	RA	RB	S	U	V	W	Z
				—	TN	TF								
63	9	M10	14	Rc1/4	NPT1/4	G1/4	15	18	10.5	93	47.5	69	12	19
80	11	M12	17.5	Rc3/8	NPT3/8	G3/8	16	22	13.5	112.5	57.5	89	14	26
100	11	M12	17.5	Rc3/8	NPT3/8	G3/8	23	22	13.5	132.5	67.5	113	16	26

Auto Switches/Proper Mounting Positions and Height for Stroke End Detection

Reed switch
D-A9□

Solid state switch
D-M9□
D-M9BAL
D-M9□W

ø12

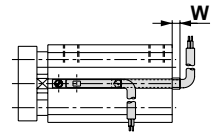
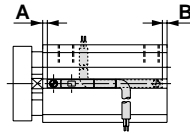

ø16, ø20, ø25

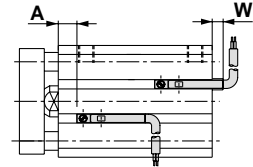
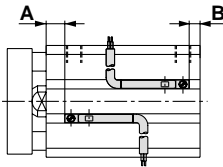

ø32 to ø100

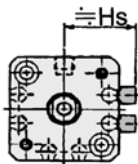
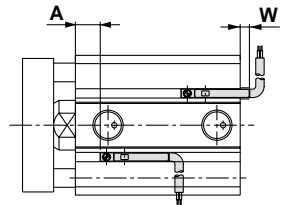
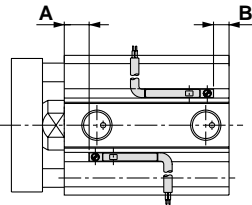

* Mounting height "Hs" exists only for the D-M9BAL type.

Auto switch model		D-A9□			D-M9□ D-M9□W			D-M9BAL			
Symbol		A	B	W	A	B	W	A	B	W	HS
Bore size (mm)	12	1.5	0.5	1.5 (4)	5.5	4.5	5.5	4.5	3.5	14.5	16.5
	16	2	0	2 (4.5)	6	4	6	5	3	15	18.5
	20	6	3.5	-1.5 (1)	10	7.5	2.5	9	6.5	11.5	22
	25	7	5.5	-3.5 (-1)	11	9.5	0.5	10	8.5	9.5	24
	32	8	5	-3 (-0.5)	12	9	1	11	8	10	26.5
	40	12	7.5	-5.5 (-3)	16	11.5	-1.5	15	10.5	7.5	30
	50	10	10.5	-8.5 (-6)	14	14.5	-4.5	13	13.5	4.5	36
	63	12.5	13.5	-11.5 (-9)	16.5	17.5	-7.5	15.5	16.5	1.5	39.5
	80	15.5	18	-16 (-13.5)	19.5	22	-12	18.5	21	-3	49.5
100	20	23	-21 (-18.5)	24	27	-17	23	26	-8	59.5	

Note 1) The dimension inside () is for D-A93.

Note 2) Minus in "W" column signifies the inner mounting from the edge of a cylinder.

Reed switch
D-A7□H
D-A80H

Solid state switch
D-F7□
D-J79
D-F7□W
D-J79W
D-F7BAL
D-F79F
D-F7NTL

ø32 to ø100

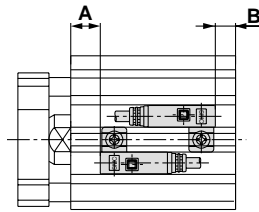
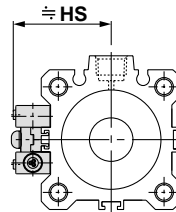

Auto switch model		D-A7□H D-A80H			D-F7□ D-J79 D-F7□W			D-J79W D-F7BAL D-F79F			D-F7NTL		
Symbol		A	B	Hs	A	B	Hs	A	B	Hs	A	B	Hs
Bore size (mm)	32	9.5	6.5	32.5	9.5	6.5	32.5	14.5	11.5	32.5	14.5	11.5	32.5
	40	13.5	9	36	13.5	9	36	18.5	14	36	18.5	14	36
	50	11.5	12	42	11.5	12	42	16.5	17	42	16.5	17	42
	63	14	15	48.5	14	15	48.5	15	16	48.5	15	16	48.5
	80	18	18.5	58.5	18	18.5	58.5	19	19.5	58.5	19	19.5	58.5
	100	21.5	24.5	68.5	21.5	24.5	68.5	22.5	25.5	68.5	22.5	25.5	68.5

Solid state switch
D-P5DW

ø40 to ø100

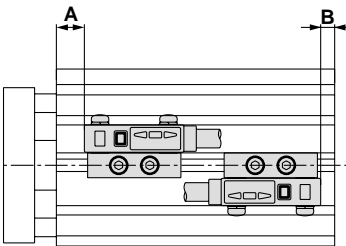
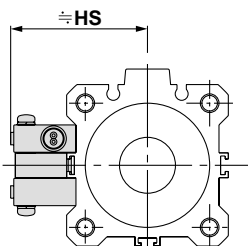

Auto switch model		D-P5DW		
Symbol		A	B	Hs
Bore size (mm)	40	9	4.5	44
	50	7	7.5	50
	63	9.5	10.5	56.5
	80	13.5	14	66.5
100	17	20	76.5	

Series CQM

Auto Switches/Proper Mounting Positions and Height for Stroke End Detection

Reed switch
D-A9□V

Solid state switch
D-M9□V
D-M9□WV

∅12

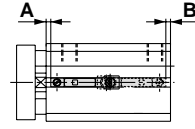
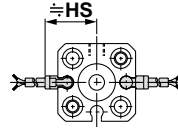

∅16, ∅20, ∅25

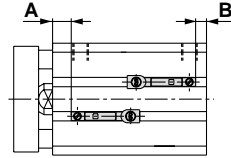
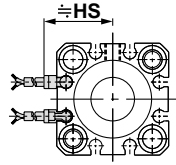

∅32 to ∅100

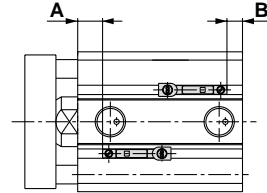
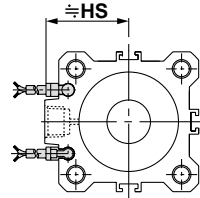

(mm)

Auto switch model		D-A9□V			D-M9□V D-M9□WV		
Symbol		A	B	Hs	A	B	Hs
Bore size (mm)	12	1.5	0.5	17	5.5	4.5	19
	16	2	0	19	6	4	21
	20	6	3.5	22.5	10	7.5	24
	25	7	5.5	24.5	11	9.5	26
	32	8	5	27	12	9	29
	40	12	7.5	30.5	16	11.5	32.5
	50	10	10.5	36.5	14	14.5	42
	63	12.5	13.5	40	16.5	17.5	42
80	16.5	17	50	20.5	21	52	
100	20	23	60	24	27	62	

Reed switch
D-A7□
D-A80
D-A73C
D-A80C
D-A79W

Solid state switch
D-F7□V
D-J79C
D-F7□WV
D-F7BAVL

∅32 to ∅100

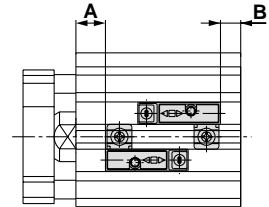
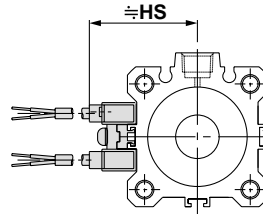

(mm)

Auto switch model		D-A7□ D-A80			D-A73C D-A80C			D-A79W			D-F7□V D-F7BAVL D-F7□WV			D-J79C		
Symbol		A	B	Hs	A	B	Hs	A	B	Hs	A	B	Hs	A	B	Hs
Bore size (mm)	32	9(9.5)	6(6.5)	31.5	9.5	6.5	38.5	6.5	3.5	34	9.5	6.5	35	9.5	6.5	38
	40	13(13.5)	8.5(9)	35	13.5	9	42	10.5	6	37.5	13.5	9	38.5	13.5	9	41.5
	50	11(11.5)	11.5(12)	41	11.5	12	48	12	8.5	43.5	11.5	12	44.5	11.5	12	47.5
	63	13.5(14)	14.5(15)	47.5	14	15	54.5	11	12	50	14	15	51	14	15	54
	80	17.5(18)	18(18.5)	57.5	18	18.5	64.5	15	15.5	60	18	18.5	61	18	18.5	64
100	21(21.5)	24(24.5)	67.5	21.5	24.5	74.5	18.5	21.5	70	21.5	24.5	71	21.5	24.5	74	

The dimension inside () is for D-A72.

The number of surfaces and grooves where an auto switch can be mounted (as direct mounting).

The number of the surfaces and grooves where the auto switch can be mounted, by switch type, are shown in the table below.

View from piston rod end

Switch type	D-A9□(V), M9□(V), M9□W(V)				D-A7□, A8□, F7□, J7□			
	A (Mounting groove no.)	B (Mounting groove no.)	C (Mounting groove no.)	D (Mounting groove no.)	A (Mounting groove no.)	B (Mounting groove no.)	C (Mounting groove no.)	D (Mounting groove no.)
Bore size (mm)								
12	—	○ (1)	○ (1)	○ (1)	—	—	—	—
16	—	○ (2)	○ (2)	○ (2)	—	—	—	—
20	○ (2)	○ (2)	○ (2)	○ (2)	—	—	—	—
25	○ (2)	○ (2)	○ (2)	○ (2)	—	—	—	—
32	○ (2)	—	—	—	—	○	○	○
40	○ (2)	—	—	—	—	○	○	○
50	○ (2)	—	—	—	—	○	○	○
63	○ (2)	○ (2)	○ (2)	○ (2)	—	○	○	○
80	○ (2)	○ (2)	○ (2)	○ (2)	—	○	○	○
100	○ (2)	○ (2)	○ (2)	○ (2)	—	○	○	○

Operating Range

Auto switch model	Bore size (mm)									
	12	16	20	25	32	40	50	63	80	100
D-F7□, D-F7□V D-J79, D-J79C D-F7□W, D-F7□WV D-J79W D-F7BAL, D-F7BAVL D-F7NTL, D-F79F	—	—	—	—	6	6	6	6.5	6.5	7
D-M9□W, D-M9□WV D-M9BAL	3	4	5	5.5	5.5	5.5	5.5	6.5	5.5	6.5
D-A7□, D-A80	—	—	—	—	12	11	10	12	12	13
D-A9□(V)	6	7.5	10	10	9.5	9.5	9.5	11.5	9	11.5
D-M9□, D-M9□(V)	2	2.5	3.5	3.5	4	4	4	5	5	5.5

* The operating ranges are provided as guidelines including hystereses and are not guaranteed values (assuming approximately ±30% variations). They may vary significantly with ambient environments.

Auto Switch Mounting Bracket/Part No.

Bore size (mm)	Mounting bracket part no.	Note	Applicable switch	
			Reed switch	Solid state switch
32, 40 50, 63 80, 100	BQ-2	<ul style="list-style-type: none"> Switch mounting screw (M3 x 0.5 x 10 ℓ) Switch spacer Switch mounting nut 	D-A7□, A80 D-A73C, A80C D-A7□H, A80H D-A79W	D-F7□, J79 D-F7□V D-J79C D-F7□W, J79W D-F7□WV D-F7BAL, F7BAVL D-F79F D-F7NTL
40, 50 63, 80 100	BQP1-050	<ul style="list-style-type: none"> Switch mounting bracket Switch mounting nut Hexagon socket head cap bolt (M3 x 0.5 x 14 ℓ, spring washer 2 pcs.) Round head Phillips screw (M3 x 0.5 x 16 ℓ, spring washer 2 pcs.) 	—	D-P5DWL

[Mounting screws set made of stainless steel]

The following set of mounting screws (nut included) made of stainless steel is also available. Use it in accordance with the operating environment. (Please order the auto switch spacer separately, since it is not included.)

For BBA2: D-A7/A8/F7/J7

"D-F7BAL/F7BAVL" switch is set on the cylinder with the stainless steel screws above when shipped. When a switch is shipped independently, "BBA2" screws are attached.

Minimum Auto Switch Mounting Stroke

Bore size (mm)	Auto switch model Number of auto switch	(mm)						
		D-A9□	D-A9□V	D-M9□	D-M9□W	D-M9□V	D-M9□WV	D-M9BAL
12 to 25	2 pcs.	10	10	15	15	5	10	25
	1 ps.	10	5	15	15	5	10	25
32, 40, 50, 63, 80, 100	2 pcs.	10	10	10	15	5	15	20
	1 pc.	10	5	10	15	5	10	20

Bore size (mm)	Auto switch model Number of auto switches	(mm)							
		D-F7□V D-J79C	D-A7□ D-A8□ D-A73C D-A80C	D-F7□WV D-F7BAVL	D-A80H D-F7□ D-J79	D-A79W	D-F7□W D-J79W D-F7BAL D-F7NT D-F79F	D-P5DW	
32, 40, 50, 63, 80, 100	2 pcs.	5	10	15	15	20	20	15	
	1 pc.	5	5	10	15	15	20	15	

Besides the models listed in "How to Order," the following auto switches are applicable. Refer to Best Pneumatics for detailed specifications.

Type	Model	Electrical entry	Features	Applicable bore size
Solid state switch	D-F7NTL	Grommet (In-line)	With timer	ø32 to ø100

* With pre-wire connector is available for D-F7NTL type, too. Contact SMC for details. For details, refer to Best Pneumatics.

* Contact SMC for detailed normally closed solid (N.C. = b contact) state auto switches such as D-F9G and D-F9H. For details, refer to Best Pneumatics.

Auto Switch Mounting

To mount auto switches, follow the instruction illustrated below.

ø12 to ø100/Direct mounting

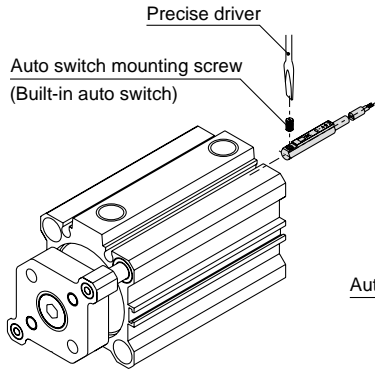

- Use a watchmakers screwdriver with a handle 5 to 6 mm in diameter when tightening the auto switch mounting screw. Tightening torque should be set 0.10 to 0.20 N·m.

ø32 to ø100/Rail mounting

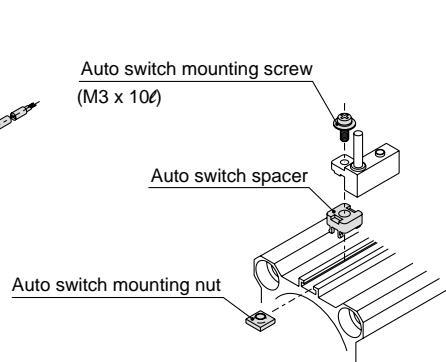

- Tightening torque of auto switch mounting screw should be set 0.5 to 0.7 N·m.
- * In the case of cylinders with built-in magnets, unassembled auto switch mounting brackets are packed together when shipped.

ø40 to ø100/D-P5DWL

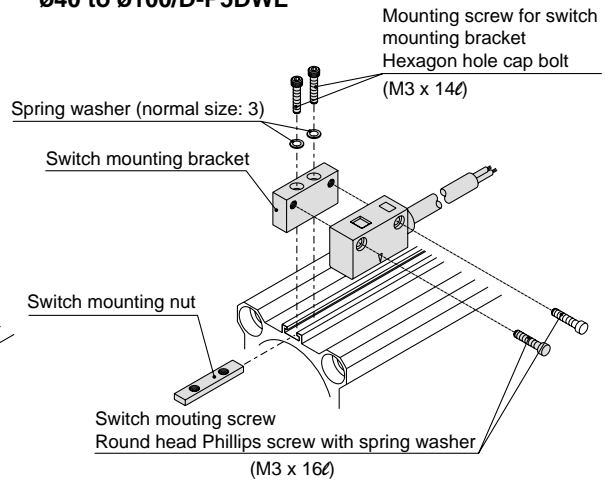

1. Mount the switch mounting bracket onto the switch mounting nut by tightening mounting screw for bracket fixing lightly through the mounting hole on the top of bracket.
2. Insert the switch mounting bracket assembly (bracket + nut) into the mounting groove and set it at the auto switch mounting position.
3. Push the auto switch mounting screw lightly into the auto switch through the mounting hole to fix switch mounting bracket tentatively.
4. After reconfirming the detecting position, tighten the mounting screw for switch mounting bracket and switch mounting screw, and fix the auto switch. (Tightening torque should be 0.5 to 0.7 N·m.)

Series CQM

Auto Switch Specifications

Auto Switch Common Specifications

Type	Reed switch	Solid state switch
Leakage current	None	3-wire: 100 μ A or less, 2-wire: 0.8 mA or less
Operating time	1.2 ms	1 ms or less ^{Note 2)}
Impact resistance	300 m/s ²	1000 m/s ²
Insulation resistance	50 M Ω or more at 500 VDC Mega (between lead wire and case)	
Withstand voltage	1500 VAC for 1 min. ^{Note 1)} (between lead wire and case)	1000 VAC for 1 min. (between lead wire and case)
Ambient temperature	-10 to 60°C	
Enclosure	IEC529 standard IP67, watertight (JIS C 0920)	

Note1) Connector style (D-A73C/A80C) and A9/A9 □V style: 1000 V AC/min. (between lead wire and the case)

Note 2) Except for solid state switch with timer (F7NTL) and solid state switch for strong magnetic field resistant 2-colour display (D-P5DWL).

Lead Wire Length

Lead wire length indication

(Example) **D-M9P****L**

Lead wire length

Nil	0.5 m
L	3 m
Z	5 m
N*	None

* Applicable for the connector style (D-□□C) only.

Note 1) Lead wire length Z: 5 m applicable auto switches

Reed switch: D-A73 (C) (H), A80C

Solid state switch: All types are produced upon receipt of order.

Note 2) The standard lead wire length of solid state switch with timer or with water tight 2-colour display is 3 metres. (Not available 0.5 m)

Note 3) The standard lead wire length of solid state switch for strong magnetic fields resistant 2-colour display is 3 m and 5 m.

Note 4) For solid state switches with flexible wire specification, add "61" at the end of the lead wire length.

(Example) **D-M9PVL-61**

Flexible specification

Part no. of lead wires with connectors

(applicable only for connector type)

Model	Lead wire length
D-LC05	0.5 m
D-LC30	3 m
D-LC50	5 m

Auto Switch Hysteresis

Hysteresis is the distance between the position at which piston movement operates an auto switch to the position at which reverse movement turns the switch off. This hysteresis is included in part of the operating range (one side).

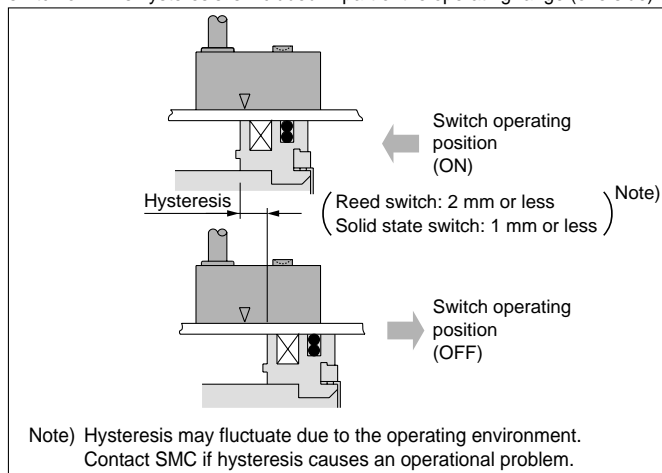

Contact Protection Box/CD-P11, CD-P12

<Applicable switch type>

D-A9 and D-A9□V, D-A7□(H), (C) and D-A80□(H), (C) type switches do not have internal contact protection circuits.

① The operated load is an induction load.

② The length of wiring to the load is 5 m or more.

③ The load voltage is 100 VAC and 200 VAC.

A contact protection box should be used in any of the above situations. The lifetime of the contact may be shortened.

D-A72 (H) must be used with the contact protection box regardless of load styles and lead wire length.

Specifications

Part No.	CD-P11		CD-P12
Load voltage	100 VAC	200 VAC	24 VDC
Max. load current	25 mA	12.5 mA	50 mA

* Lead wire length — Switch connection side: 0.5 m
Load connection side: 0.5 m



Internal Circuit

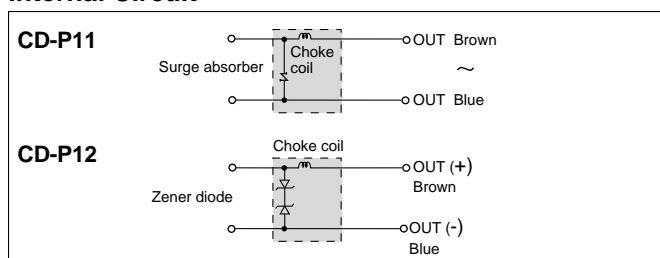

Dimensions

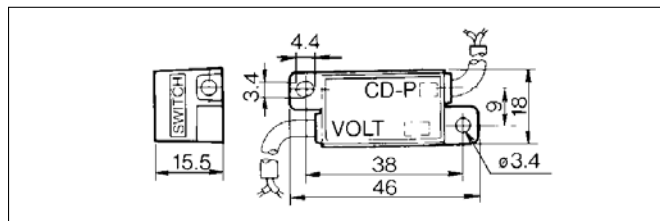

Contact Protection Box/Connection

To connect a switch unit to a contact protection box, connect the lead wire from the side of the contact protection box marked SWITCH to the lead wire coming out of the switch unit. The switch unit should be kept as close as possible to the contact protection box with a lead wire that is no more than 1 metre in length.

Series CQM Auto Switch Connections and Examples

Basic Wiring

Solid state 3-wire, NPN

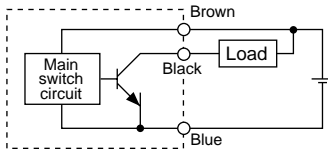

Solid state 3-wire, PNP

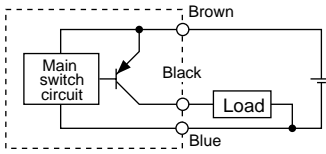

2-wire (Solid state)

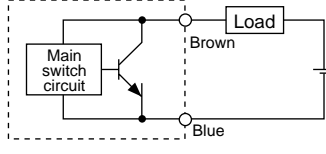

2-wire (Reed)

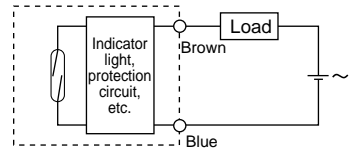

(When power supply for switch and load are separate.)

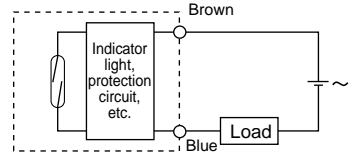
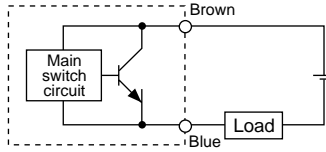
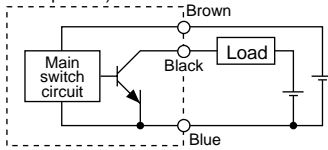

Examples of Connection to PLC

Sink input specifications

3-wire, NPN

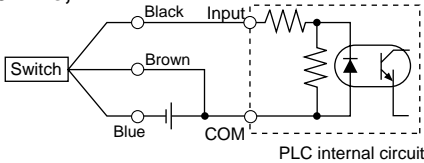

2-wire

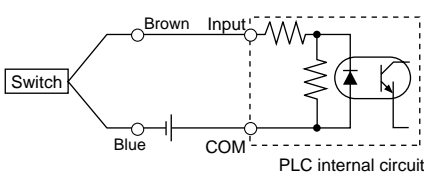

Source input specifications

3-wire, PNP

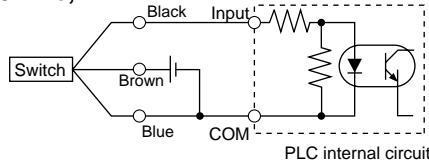

2-wire

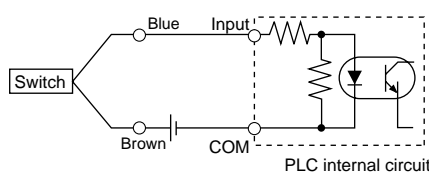

Connect according to the applicable PLC input specifications, as the connection method will vary depending on the PLC input specifications.

Connection Examples for AND (Series) and OR (Parallel)

3-wire

AND connection for NPN output (using relays)

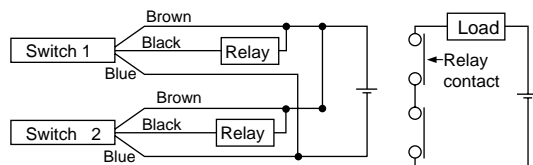

AND connection for NPN output (performed with switches only)

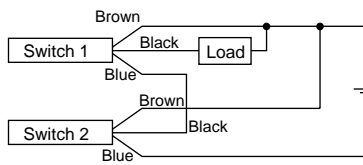

OR connection for NPN output

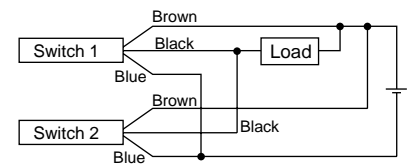

The indicator lights will light up when both switches are turned ON.

2-wire with 2 switches AND connection

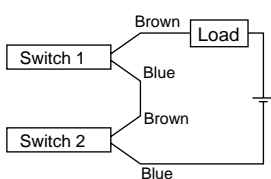

When two switches are connected in series, a load may malfunction because the load voltage will decline when in the ON state. The indicator lights will light up if both of the switches are in the ON state.

2-wire with 2 switches OR connection

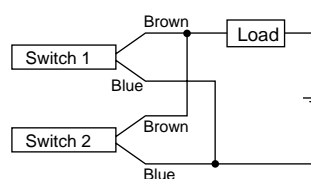

(Solid state)

When two switches are connected in parallel, malfunction may occur because the load voltage will increase when in the OFF state.

(Reed)

Because there is no current leakage, the load voltage will not increase when turned OFF. However, depending on the number of switches in the ON state, the indicator lights may sometimes get dark or not light up, because of dispersion and reduction of the current flowing to the switches.

$$\begin{aligned} \text{Load voltage at ON} &= \text{Power supply voltage} - \text{Residual voltage} \times 2 \text{ pcs.} \\ &= 24\text{V} - 4\text{V} \times 2 \text{ pcs.} \\ &= 16\text{V} \end{aligned}$$

Example: Power supply voltage is 24VDC
Voltage decline in switch is 4V

$$\begin{aligned} \text{Load voltage at OFF} &= \text{Leakage current} \times 2 \text{ pcs.} \times \text{Load impedance} \\ &= 1\text{mA} \times 2 \text{ pcs.} \times 3\text{k}\Omega \\ &= 6\text{V} \end{aligned}$$

Example: Load impedance is 3kΩ
Leakage current from switch is 1mA

Reed Switch: Direct Mounting Style D-A90(V)/D-A93(V)/D-A96(V)



For details about certified products conforming to international standards, visit us at www.smcworld.com.

Auto Switch Specifications

PLC: Abbreviation for Programmable Logic Controller

D-A90/D-A90V (Without indicator light)			
Auto switch part no.	D-A90/D-A90V		
Applicable load	IC circuit, Relay, PLC		
Load voltage	24 V AC/DC or less	48 V AC/DC or less	100 V AC/DC or less
Maximum load current	50 mA	40 mA	20 mA
Contact protection circuit	None		
Internal resistance	1 Ω or less (including lead wire length of 3 m)		
D-A93/D-A93V/D-A96/D-A96V (With indicator light)			
Auto switch part no.	D-A93/D-A93V		D-A96/D-A96V
Applicable load	Relay, PLC		IC circuit
Load voltage	24 VDC	100 VAC	4 to 8 VDC
Load current range and max. load current	Note 3) 5 to 40 mA	5 to 20 mA	20 mA
Contact protection circuit	None		
Internal voltage drop	D-A93 — 2.4 V or less (to 20 mA)/3 V or less (to 40 mA) D-A93V — 2.7 V or less		0.8 V or less
Indicator light	Red LED lights when ON		

Grommet Electrical entry: In-line



Caution

Operating Precautions

Fix the switch with the existing screw installed on the switch body. The switch may be damaged if a screw other than the one supplied, is used.

Auto Switch Internal Circuit

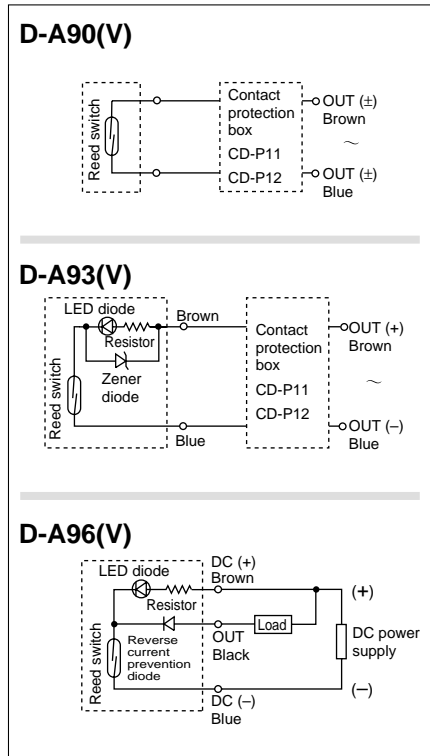

- Note) ① In a case where the operation load is an inductive load.
② In a case where the wiring load is greater than 5 m.
③ In a case where the load voltage is 100 VAC.

Please use the auto switch with a contact protection box any of the above mentioned cases. (For details about the contact protection box, refer to page 14.)

Lead wires

D-A90(V)/D-A93(V) — Oilproof vinyl heavy-duty cord: $\phi 2.7$, 0.18 mm² x 2 cores (Brown, Blue), 0.5 m
D-A96(V) — Oilproof vinyl heavy-duty cord: $\phi 2.7$, 0.15 mm² x 3 cores (Brown, Black, Blue), 0.5 m

Note 1) Refer to page 14 for reed switch common specifications.

Note 2) Refer to page 14 for lead wire lengths.

Weight

Unit: g

Model	D-A90	D-A90V	D-A93	D-A93V	D-A96	D-A96V
Lead wire length: 0.5 m	6	6	6	6	8	8
Lead wire length: 3 m	30	30	30	30	41	41

Dimensions

Unit: mm

D-A90/D-A93/D-A96

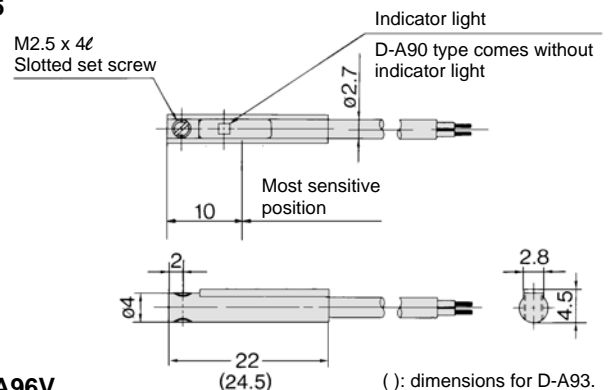

D-A90V/D-A93V/D-A96V

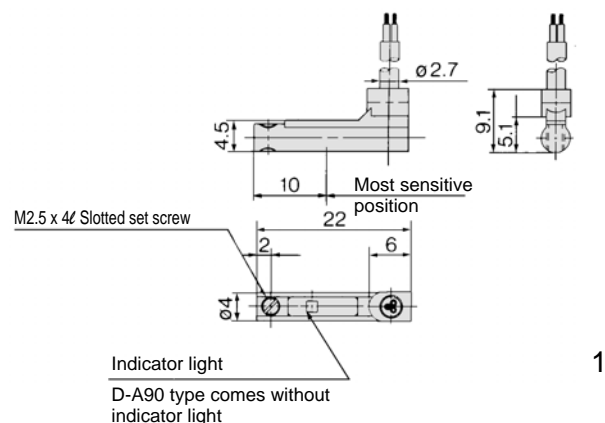

Indicator light
D-A90 type comes without indicator light

Solid State Switch: Direct Mounting Style D-M9N(V)/D-M9P(V)/D-M9B(V)



For details about certified products conforming to international standards, visit us at www.smcworld.com.

Auto Switch Specifications

PLC: Abbreviation of Programmable Logic Controller

D-M9□, D-M9□V (With indicator light)						
Auto switch part no.	D-M9N	D-M9NV	D-M9P	D-M9PV	D-M9B	D-M9BV
Electrical entry direction	In-line	Perpendicular	In-line	Perpendicular	In-line	Perpendicular
Wiring type	3-wire			2-wire		
Output type	NPN		PNP		—	
Applicable load	IC circuit, Relay, PLC				24 VDC relay, PLC	
Power supply voltage	5, 12, 24 VDC (4.5 to 28 V)				—	
Current consumption	10 mA or less				—	
Load voltage	28 VDC or less		—		24 VDC (10 to 28 VDC)	
Load current	40 mA or less				2.5 to 40 mA	
Internal voltage drop	0.8 V or less				4 V or less	
Leakage current	100 μA or less at 24 VDC				0.8 mA or less	
Indicator light	Red LED lights when ON.					

Lead wires

Oilproof vinyl heavy-duty cord: $\phi 2.7 \times 3.2$ ellipse, 0.15 mm²,

D-M9B(V) 0.15 mm² x 2 cores

D-M9N(V), D-M9P(V) 0.15 mm² x 3 cores

Note 1) Refer to page 14 for auto switch common specifications.

Note 2) Refer to page 14 for lead wire lengths.

Grommet

- 2-wire load current is reduced (2.5 to 40 mA)
- Lead-free
- UL certified (style 2844) lead cable is used.



Caution

Operating Precautions

Fix the switch with the existing screw installed on the switch body. The switch may be damaged if a screw other than the one supplied, is used.

Auto Switch Internal Circuit

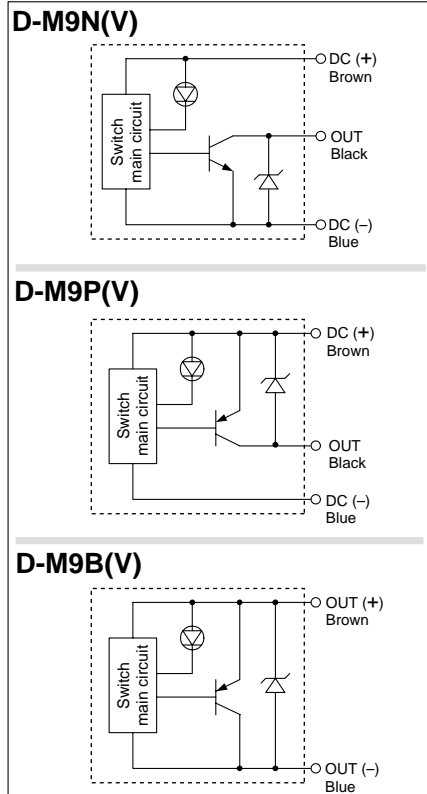

Weight

Unit: g

Auto switch part no.	D-M9N(V)	D-M9P(V)	D-M9B(V)
Lead wire length (m)	0.5	8	7
	3	41	38
	5	68	63

Dimensions

Unit: mm

D-M9□

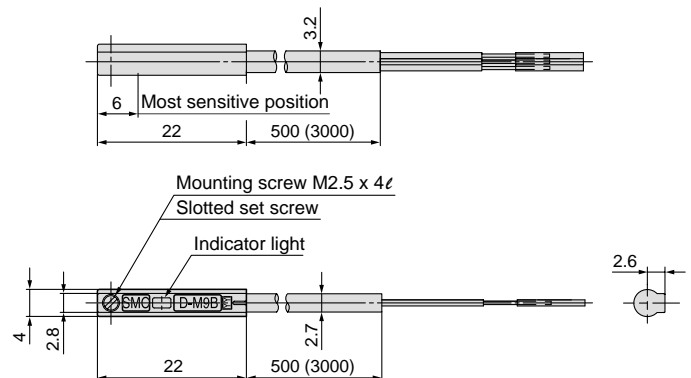

D-M9□V

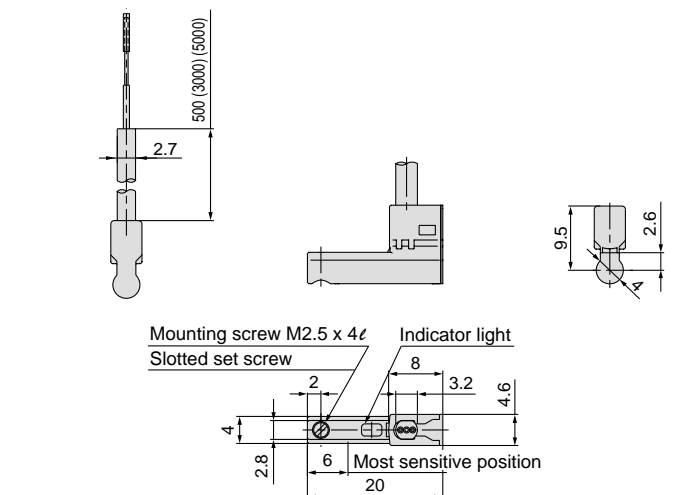

2-colour Indication Type, Solid State Switch: Direct Mounting Style D-F9NW(V)/D-F9PW(V)/D-F9BW(V)



For details about certified products conforming to international standards, visit us at www.smcworld.com.

Auto Switch Specifications

PLC: Abbreviation for Programmable Logic Controller

D-F9□W/D-F9□WV (With indicator light)						
Auto switch part no.	D-F9NW	D-F9NWV	D-F9PW	D-F9PWV	D-F9BW	D-F9BWV
Electrical entry direction	In-line	Perpendicular	In-line	Perpendicular	In-line	Perpendicular
Wiring type	3-wire			2-wire		
Output type	NPN		PNP		—	
Applicable load	IC circuit, Relay, PLC				24 VDC relay, PLC	
Power supply voltage	5, 12, 24 VDC (4.5 to 28 VDC)				—	
Current consumption	10 mA or less				—	
Load voltage	28 VDC or less		—		24 VDC (10 to 28 VDC)	
Load current	40 mA or less		80 mA or less		5 to 40 mA	
Internal voltage drop	1.5 V or less (0.8 V or less at 10 mA load current)		0.8 V or less		4 V or less	
Leakage current	100 μA or less at 24 VDC				0.8 mA or less	
Indicator light	Operating position Red LED lights up Optimum operating position Green LED lights up					

Grommet



Caution

Operating Precautions

Fix the switch with the existing screw installed on the switch body. The switch may be damaged if a screw other than the one supplied, is used.

Auto Switch Internal Circuit

D-F9NW(V)

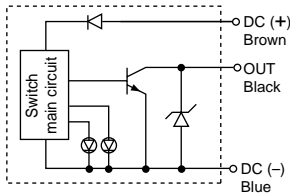

D-F9PW(V)

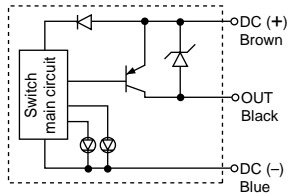

D-F9BW(V)

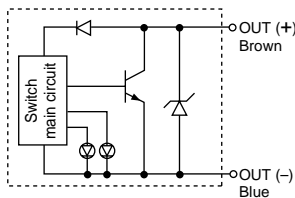

Indicator light/Display method

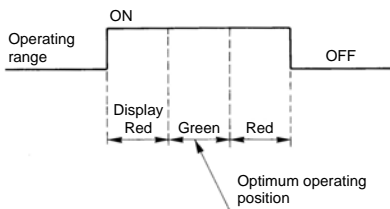

- Lead wires
Oilproof vinyl heavy-duty cord: $\phi 2.7$, 0.15 mm² x 3 cores (Brown, Black, Blue), 0.18 mm² x 2 cores (Brown, Blue), 0.5 m
- Note 1) Refer to page 14 for auto switch common specifications.
- Note 2) Refer to page 14 for lead wire lengths.

Weight

Unit: g

Auto switch part no.	D-F9NW(V)	D-F9PW(V)	D-F9BW(V)
Lead wire length (m)	0.5	7	7
	3	34	32
	5	56	52

Dimensions

Unit: mm

D-F9□W

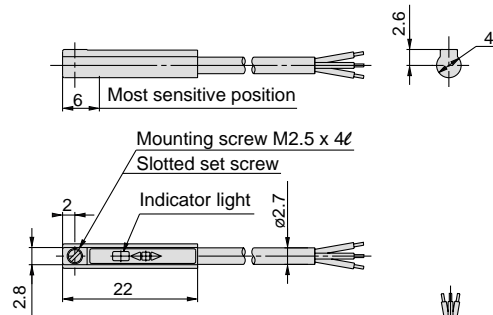

D-F9□WV

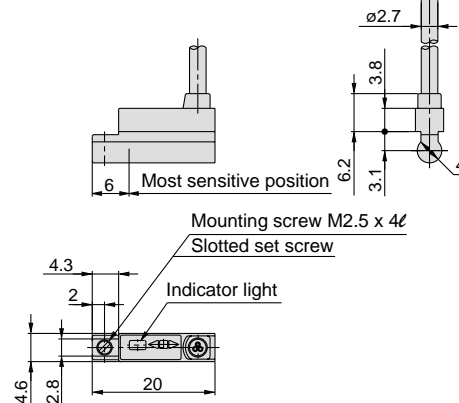

Water Resistant 2-colour Inducation Type Solid State Switch: Direct Mounting Style D-M9BAL



Refer to www.smcworld.com for details of products compatible with overseas standards.

Auto Switch Specifications

PLC: Programmable Logic Controller

D-M9BAL (With indicator light)	
Auto switch part no.	D-M9BAL
Wiring type	2-wire
Output type	—
Applicable load	24 VDC relay, PLC
Power supply voltage	—
Current consumption	—
Load voltage	24 VDC (10 to 28 VDC)
Load current	5 to 30 mA
Internal voltage drop	5 V or less
Leakage current	1 mA or less at 24 VDC
Indicator light	Operating position Red LED lights up Optimum operating position Green LED lights up

Grommet

Water (coolant) resistant type



Caution

Operating Precautions

- Consult with SMC if using coolant liquid other than water based solution.
- Do not use anything other than the mounting screws attached to the auto switch body to secure the switch. If screws other than those specified are used, it may cause the switch to be damaged.

Lead wires

Oilproof vinyl heavy-duty cord, $\phi 2.7$, 0.5 m
0.18 mm² x 2 cores (Brown, Blue)

Note 1) Refer to page 14 for auto switch common specifications.

Note 2) Refer to page 14 for lead wire lengths.

Weight

Unit: g

Model		D-M9BA
Lead wire length (m)	0.5	—
	3	37
	5	57

Auto Switch Internal Circuit

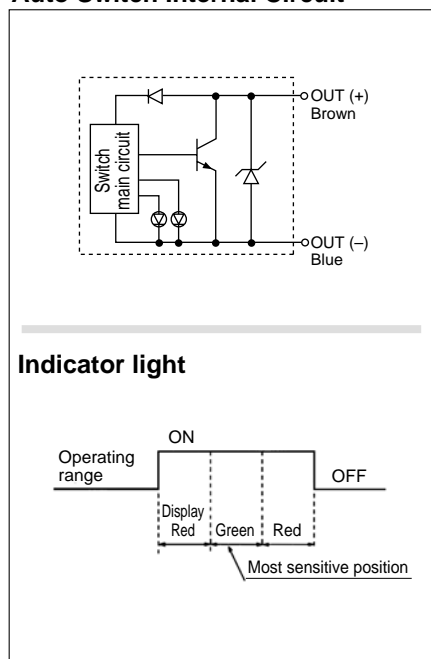

Indicator light

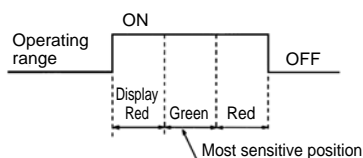

Dimensions

Unit: mm

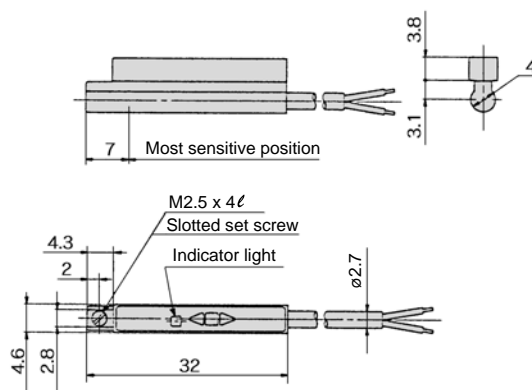



Series CQM

Safety Instructions

These safety instructions are intended to prevent a hazardous situation and/or equipment damage. These instructions indicate the level of potential hazard by a label of "**Caution**", "**Warning**" or "**Danger**". To ensure safety, be sure to observe ISO 4414 Note 1), JIS B 8370 Note 2) and other safety practices.

⚠ Caution : Operator error could result in injury or equipment damage.

⚠ Warning : Operator error could result in serious injury or loss of life.

⚠ Danger : In extreme conditions, there is a possible result of serious injury or loss of life.

Note 1) ISO 4414 : Pneumatic fluid power --General rules relating to systems

Note 2) JIS B 8370: Pneumatic system axiom

⚠ Warning

1. The compatibility of pneumatic equipment is the responsibility of the person who designs the pneumatic system or decides its specifications.

Since the products specified here are used in various operating conditions, their compatibility for the specific pneumatic system must be based on specifications or after analysis and/or tests to meet your specific requirements. The expected performance and safety assurance will be the responsibility of the person who has determined the compatibility of the system. This person should continuously review the suitability of all items specified. Referring to the latest catalogue information with a view to giving due consideration to any possibility of equipment failure when constructing a system.

2. Only trained personnel should operate pneumatically operated machinery and equipment.

Compressed air can be dangerous if handled incorrectly. Assembly, handling or repair of pneumatic systems should be performed by trained and experienced operators.

3. Do not service machinery/equipment or attempt to remove components until safety is confirmed.

1. Inspection and maintenance of machinery/equipment should only be performed after confirmation of safe locked-out control positions.
2. When equipment is to be removed, confirm the safety process as mentioned above. Cut the supply pressure for this equipment and exhaust all residual compressed air in the system.
3. Before machinery/equipment is restarted, take measures to prevent shooting-out of cylinder piston rod, etc. (Bleed air into the system gradually to create back pressure.)

4. Contact SMC if the product is to be used in any of the following conditions:

1. Conditions and environments beyond the given specifications, or if product is used outdoors.
2. Installation on equipment in conjunction with atomic energy, railway, air navigation, vehicles, medical equipment, food and beverages, recreation equipment, emergency stop circuits, press applications, or safety equipment.
3. An application which has the possibility of having negative effects on people, property, or animals, requiring special safety analysis.



Series CQM Actuator Precautions 1

Be sure to read before handling.

Design

⚠ Warning

1. There is a danger of sudden action by air cylinders if sliding parts of machinery are twisted, etc. and changes in forces occur.

In such cases, human injury may occur; e.g., by catching hands or feet in the machinery, or damage to the machinery itself may occur. Conduct adjustment to ensure smooth movement of the machine and plan a design to avoid human injury.

2. A protective cover is recommended to minimize the risk of human injury.

If a driven object or moving parts of the cylinder pose a danger of personal injury, design the structure to avoid contact with the human body.

3. Securely tighten all stationary parts and connected parts so that they will not become loose.

When a cylinder operates at a high frequency or is installed where there is a lot of vibration, ensure that all parts remain secure.

4. A deceleration circuit or shock absorber, etc., may be required.

When a driven object is operated at a high speed or the load is heavy, the cylinder's cushion will not be sufficient to absorb the impact. Install a deceleration circuit to reduce the speed before cushioning, or install an external shock absorber to relieve the impact. In this case, the rigidity of the machinery should also be examined.

5. Consider a possible drop in operating pressure due to a power outage, etc.

When a cylinder is used in a clamping mechanism, there is a danger of work pieces dropping if there is a decrease in clamping force due to a drop in circuit pressure caused by a power outage, etc. Therefore, safety equipment should be installed to prevent damage to machinery and/or human injury. Suspension mechanisms and lifting devices also require consideration for drop prevention.

6. Consider a possible loss of power source.

Measures should be taken to protect against human injury and equipment damage in the event that there is a loss of power to equipment controlled by pneumatics, electricity or hydraulics, etc.

7. Design circuitry to prevent sudden lurching of driven objects.

When a cylinder is driven by an exhaust centre type directional control valve or when it starts-up after residual pressure is exhausted from the circuit, etc., the piston and its driven object will shoot out at a high speed if pressure is applied to one side of the cylinder because of the absence of air pressure inside the cylinder. Therefore, equipment should be selected and circuits designed to prevent sudden shoot-outs because, there is a danger of human injury and/or damage to equipment when this occurs.

8. Consider emergency stops.

Design so that human injury and/or damage to machinery and equipment will not be caused when machinery is stopped by a safety device under abnormal conditions, a power outage or a manual emergency stop.

9. Consider the action when operation is restarted after an emergency stop or abnormal stop.

Design the machinery so that human injury or equipment damage will not occur upon restart of operation. When the cylinder has to be reset at the starting position, install manual safety equipment.

Selection

⚠ Warning

1. Confirm the specifications.

The products advertised in this catalogue are designed according to use in industrial compressed air systems. If the products are used in conditions where pressure, temperature, etc., are out of specifications, damage and/or malfunction may be caused. Do not use in these conditions. (Refer to specifications.)

Consult with SMC if you use a fluid other than compressed air.

2. Intermediate stops

When intermediate stopping of a cylinder piston is performed with a 3-position closed centre type directional control valve, it is difficult to achieve stopping positions as accurate and precise as with hydraulic pressure due to the compressibility of air.

In addition, since valves and cylinders are not guaranteed for zero air leakage, it may not be possible to hold a stopped position for an extended period of time. Consult with SMC in cases where you need to hold a stopped position for long periods.

⚠ Caution

1. Operate within the limits of the maximum usable stroke.

The piston rod will be damaged if operated beyond the maximum stroke. Refer to the air cylinder model selection procedure for the maximum useable stroke.

2. Operate the piston within a range such that collision damage will not occur at the stroke end.

3. Use a speed controller to adjust the cylinder drive speed, gradually increasing from a low speed to the desired speed setting.

Mounting

⚠ Caution

1. Be certain to match the rod shaft centre with the direction of the load and movement when connecting.

When not properly matched, problems may arise with the rod and tube, and damage may be caused due to friction on areas such as the inner tube surface, bushings, rod surface and seals.

2. When an external guide is used, connect the rod end and the load in such a way that there is no interference at any point within the stroke.

3. Do not scratch or gouge the sliding parts of the cylinder tube or tube rod, etc., by striking or grasping them with other objects.

Cylinder bores are manufactured to precise tolerances, so that even a slight deformation may cause malfunction. Also, scratches or gouges, etc., in the tube rod may lead to damaged seals and cause air leakage.

4. Prevent the seizure of rotating parts.

Prevent the seizure of rotating parts (pins, etc.) by applying grease.



Series CQM Actuator Precautions 2

Be sure to read before handling.

Mounting

⚠ Caution

5. Do not use until you can verify that equipment can operate properly.

Verify correct mounting by suitable function and leakage inspections after compressed air and power are connected following mounting, maintenance or conversions.

6. Instruction manual

The product should be mounted and operated after thoroughly reading the manual and understanding its contents.

Keep the instruction manual where it can be referred to as needed.

Piping

⚠ Caution

1. Preparation before piping

Before piping is connected, it should be thoroughly blown out with air (flushing) or washed to remove chips, cutting oil and other debris from inside the pipe.

2. Wrapping of pipe tape

When screwing in pipes and fittings, etc., be certain that chips from the pipe threads and sealing material will not ingress inside the piping.

Also, when pipe tape is used, leave 1.5 to 2 thread ridges exposed at the end of the threads.

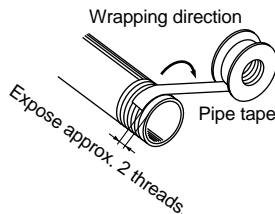

Lubrication

⚠ Caution

1. Lubrication of non-lube type cylinder

The cylinder is lubricated for life at the factory and can be used without any further lubrication.

However, in the event that it is lubricated additionally, be sure to use class 1 turbine oil (with no additives) ISO VG32.

Stopping lubrication later may lead to malfunctions because the new lubricant will cancel out the original lubricant. Therefore, lubrication must be continued once it has been started.

Air Supply

⚠ Warning

1. Use clean air.

If compressed air includes chemicals, synthetic oils containing organic solvents, salt or corrosive gases, etc., it can cause damage or malfunction.

⚠ Caution

1. Install air filters.

Install air filters at the upstream side of valves. The filtration degree should be 5 µm or finer.

Air Supply

2. Install an after cooler, air dryer or water separator (Drain Catch), etc.

Air that contains excessive drainage may cause malfunction of valves and other pneumatic equipment. To prevent this, install an after cooler, air dryer or water separator (Drain Catch).

3. Use the product within the specified range of fluid and ambient temperature.

Take measures to prevent freezing, since moisture in the circuit will be frozen below 5°C, and this may cause damage to seals and lead to malfunction.

Refer to SMC's Best Pneumatics for further details on compressed air quality.

Operating Environment

⚠ Warning

1. Do not use in environments where there is a danger of corrosion.

2. In dusty locations or where water, oil, etc. splash on the equipment, take suitable measures to protect rod.

3. When using auto switches, do not operate in an environment with strong magnetic fields.

Maintenance

⚠ Warning

1. Maintenance should be performed according to the procedure indicated in the instruction manual.

If handled improperly, malfunction and damage of machinery or equipment may occur.

2. Removal of equipment, and supply/exhaust of compressed air

When equipment is removed, first take measures to prevent dropping of driven objects and run-away of equipment, etc. Then cut off the supply pressure and electric power, and exhaust all compressed air from the system.

When machinery is restarted, proceed with caution after confirming measures to prevent cylinder lurching.

⚠ Caution

1. Drain flushing

Remove drainage from air filters regularly.



Series CQM Auto Switch Precautions 1

Be sure to read before handling.

Design and Selection

Warning

1. Confirm the specifications.

Read the specifications carefully and use this product appropriately. The product may be damaged or malfunction if it is used outside the range of specifications of current load, voltage, temperature or impact.

2. Take precautions when multiple cylinders are used close together.

When two or more auto switch cylinders are lined up in close proximity to each other, magnetic field interference may cause the switches to malfunction. Maintain a minimum cylinder separation of 40 mm. (When the allowable interval is specified for each cylinder series, use the indicated value.)

3. Pay attention to the length of time that a switch is on at an intermediate stroke position.

When an auto switch is placed at an intermediate position of the stroke and a load is driven at the time the piston passes, the auto switch will operate, but if the speed is too great, the operating time will be shortened and the load may not operate properly. The maximum detectable piston speed is:

$$V \text{ (mm/s)} = \frac{\text{Auto switch operating range (mm)}}{\text{Load operating time (ms)}} \times 1000$$

4. Keep wiring as short as possible.

<Reed switch>

As the length of the wiring to a load gets longer, the rush current at switching ON becomes greater, and this may shorten the product's life. (The switch will stay ON all the time.)

- 1) Use a contact protection box when the wire length is 5 m or longer.

<Solid state switch>

- 2) Although wire length should not affect switch function, use a wire that is 100 m or shorter.

5. Take precautions for the internal voltage drop of the switch.

<Reed switch>

- 1) Switches with an indicator light (Except D-A96, A96V, D-A76H)

- If auto switches are connected in series as shown below, take note that there will be a large voltage drop because of internal resistance in the light emitting diodes. (Refer to internal voltage drop in the auto switch specifications.)

[The voltage drop will be "n" times larger when "n" auto switches are connected.]

Even though an auto switch operates normally, the load may not operate.



- Similarly, when operating below a specified voltage, it is possible that the load may be ineffective even though the auto switch function is normal. Therefore, the formula below should be satisfied after confirming the minimum operating voltage of the load.

$$\text{Supply voltage} - \text{Internal voltage drop of switch} > \text{Minimum operating voltage of load}$$

- 2) If the internal resistance of a light emitting diode causes a problem, select a switch without an indicator light (Model A90, A90V, A80 (H), (C)).

<Solid state switch>

- 3) Generally, the internal voltage drop will be greater with a 2-wire solid state auto switch than with a reed switch. Take the same precautions as in 1) above.

Also, note that a 12 VDC relay is not applicable.

6. Pay attention to leakage current.

<Solid state switch>

With a 2-wire solid state auto switch, current (leakage current) flows to the load to operate the internal circuit even when in the OFF state.

$$\text{Current to operate load (OFF condition)} > \text{Leakage current}$$

If the condition given in the above formula is not met, it will not reset correctly (stays ON). Use a 3-wire switch if this specification cannot be satisfied.

Moreover, leakage current flow to the load will be "n" times larger when "n" auto switches are connected in parallel.

7. Do not use a load that generates surge voltage.

<Reed switch>

If driving a load such as a relay that generates a surge voltage, use a contact protection box.

<Solid state switch>

Although a zener diode for surge protection is connected at the output side of a solid state auto switch, damage may still occur if a surge is applied repeatedly. When directly driving a load which generates surge, such as a relay or solenoid valve, use a type of switch with a built-in surge absorbing element.

8. Cautions for use in an interlock circuit

When an auto switch is used for an interlock signal requiring high reliability, device a double interlock system to safeguard against malfunctions by providing a mechanical protection function, or by also using another switch (sensor) together with the auto switch. Also perform periodic inspection and confirm proper operation.

9. Ensure sufficient clearance for maintenance activities.

When designing an application, be sure to allow sufficient clearance for maintenance and inspections.



Series CQM Auto Switch Precautions 2

Be sure to read before handling.

Mounting and Adjustment

Warning

1. Do not drop or bump.

Do not drop, bump or apply excessive impacts (300m/s² or greater for reed switches and 1000m/s² or greater for solid state switches) while handling.

Although the body of the switch may not be damaged, the inside of the switch could be damaged and cause a malfunction.

2. Do not carry an actuator by the auto switch lead wires.

Never carry a cylinder by its lead wires. This may not only cause broken lead wires, but it may cause internal elements of the switch to be damaged by the stress.

3. Mount switches using the proper tightening torque.

When a switch is tightened above the torque specification, the mounting screws, or switch may be damaged. On the other hand, tightening below the torque specification may allow the switch to slip out of position.

4. Mount a switch at the centre of the operating range.

Adjust the mounting position of an auto switch so that the piston stops at the centre of the operating range (the range in which a switch is ON). (The mounting positions shown in the catalogue indicate the optimum position at the stroke end.) If mounted at the end of the operating range (around the borderline of ON and OFF), operation will be unstable.

<D-M9□>

When the D-M9 auto switch is used to replace old series auto switch, it may not activate depending on operating condition because of its shorter operating range.

Such as

- Application where the stop position of actuator may vary and exceed the operating range of the auto switch, for example, pushing, pressing, clamping operation, etc.
- Application where the auto switch is used for detecting an intermediate stop position of the actuator. (In this case the detecting time will be reduced.)

In these applications, please set the auto switch to the centre of the required detecting range.

Caution

1. Fix the switch with the appropriate screw installed on the switch body. The switch may be damaged if other screws are used.

Wiring

Warning

1. Avoid repeatedly bending or stretching lead wires.

Broken lead wires will result from repeatedly applying bending stress or stretching force to the lead wires.

2. Be sure to connect the load before power is applied.

<2-wire type>

If the power is turned ON when an auto switch is not connected to a load, the switch will be instantly damaged because of excess current.

Wiring

3. Confirm proper insulation of wiring.

Be certain that there is no faulty wiring insulation (such as contact with other circuits, ground fault, improper insulation between terminals, etc.). Damage may occur due to excess current flow into a switch.

4. Do not wire in conjunction with power lines or high voltage lines.

Wire separately from power lines or high voltage lines, avoiding parallel wiring or wiring in the same conduit with these lines. Control circuits containing auto switches may malfunction due to noise from these lines.

5. Do not allow short circuit of loads.

<Reed switch>

If the power is turned ON with a load in a short circuited condition, the switch will be instantly damaged because of excess current flow into the switch.

<Solid state switch>

D-M9□ and all models of PNP output type switches do not have built-in short circuit protection circuits. If loads are short circuited, the switches will be instantly damaged, as in the case of reed switches.

Take special care to avoid reverse wiring with the brown [red] power supply line and the black [white] output line on 3-wire type switches.

6. Avoid incorrect wiring.

<Reed switch>

A 24 VDC switch with indicator light has polarity. The brown [red] lead wire is (+), and the blue [black] lead wire is (-).

1) If connections are reversed, the switch will still operate, but the light emitting diode will not light up.

Also note that a current greater than the maximum specified one will damage a light emitting diode and make it inoperable.

Applicable models: D-A93, A93V, D-A73, D-A73H, D-A73C

<Solid state switch>

1) Even if connections are reversed on a 2-wire type switch, the switch will not be damaged because it is protected by a protection circuit, but it will remain in a normally ON state. But reverse wiring in a short circuit load condition should be avoided to protect the switch from being damaged.

2) Even if (+) and (-) power supply line connections are reversed on a 3-wire type switch, the switch will be protected by a protection circuit. However, if the (+) power supply line is connected to the blue [black] wire and the (-) power supply line is connected to the black [white] wire, the switch will be damaged.

<D-M9□>

D-M9□ does not have built-in short circuit protection circuit. Be aware that if the power supply connection is reversed (e.g. (+) power supply wire and (-) power supply wire connection is reversed), the switch will be damaged.

* Lead wire colour changes

Lead wire colours of SMC switches have been changed in order to meet NECA Standard 0402 for production beginning September, 1996 and thereafter. Please refer to the tables provided. Special care should be taken regarding wire polarity during the time that the old colours still coexist with the new colours.

2-wire

	Old	New
Output (+)	Red	Brown
Output (-)	Black	Blue

3-wire

	Old	New
Power supply	Red	Brown
GND	Black	Blue
Output	White	Black



Series CQM Auto Switch Precautions 3

Be sure to read before handling.

Wiring

⚠ Caution

1. When the cable sheath is stripped, confirm the stripping direction. The insulator may be split or damaged depending on the direction. (D-M9□ only)

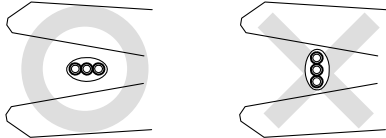

Recommended tool

Manufacturer	Model name	Model no.
VESSEL	Wire stripper	No 3000G
TOKYO IDEAL CO., LTD	Strip master	45-089

* Stripper for a round cable (ø2.0) can be used for a 2-wire type cable.

Operating Environment

⚠ Warning

1. Never use in an atmosphere of explosive gases.
The construction of the auto switch is not intended to prevent explosion. Never use in an atmosphere with an explosive gas since this may cause a serious explosion.
2. Do not use in an area where a magnetic field is generated.
The auto switch will malfunction or the magnets inside of an actuator will become demagnetized if used in such an environment.
3. Do not use in an environment where the auto switch will be continually exposed to water.
The switch satisfies the IEC standard IP67 construction (JIS C 0920: watertight construction). Nevertheless, it should not be used in applications where it is continually exposed to water splash or spray. This may cause deterioration of the insulation or swelling of the potting resin inside switch causing a malfunction.
4. Do not use in an environment with oil or chemicals.
Consult with SMC if the auto switch will be used in an environment laden with coolant, cleaning solvent, various oils or chemicals. If the auto switch is used under these conditions for even a short time, it may be adversely affected by a deterioration of the insulation, a malfunction due to swelling of the potting resin, or hardening of the lead wires.
5. Do not use in an environment with temperature cycles.
Consult with SMC if the switch is used where there are temperature cycles other than normal temperature changes, as they may adversely affected the switch internally.

Operating Environment

6. Do not use in an environment where there is excessive impact shock.

<Reed switch>

When excessive impact (300 m/s² or more) is applied to a reed switch during operation, the contact point may malfunction and generate a signal momentarily (1 ms or less) or cut off. Consult with SMC regarding the need to use a solid state switch in a specific environment.

7. Do not use in an area where surges are generated.

<Solid state switch>

When there are units (such as solenoid type lifters, high frequency induction furnaces, motors, etc.) that generate a large amount of surge in the area around an actuator with a solid state auto switch, their proximity or pressure may cause deterioration or damage to the internal circuit of the switch. Avoid sources of surge generation and crossed lines.

8. Avoid accumulation of iron debris or close contact with magnetic substances.

When a large accumulated amount of ferrous waste such as machining chips or welding spatter, or a magnetic substance (something attracted by a magnet) is brought into close proximity to a cylinder with auto switches, this may cause the auto switches to malfunction due to a loss of the magnetic force inside the cylinder.

Maintenance

⚠ Warning

1. Perform the following maintenance periodically in order to prevent possible danger due to unexpected auto switch malfunction.
 - 1) Securely tighten switch mounting screws.
If screws become loose or the mounting position is dislocated, retighten them after readjusting the mounting position.
 - 2) Confirm that there is no damage to the lead wires.
To prevent faulty insulation, replace switches or repair lead wires, etc., if damage is discovered.
 - 3) Confirm that the green light on the 2-colour display type switch lights up.
Confirm that the green LED is ON when stopped at the set position. If the red LED is ON, when stopped at the set position, the mounting position is not appropriate. Readjust the mounting position until the green LED lights up.

Other

⚠ Warning

1. Consult with SMC concerning water resistance, elasticity of lead wires, usage at welding sites, etc.



Series CQM

Specific Product Precautions

Be sure to read before handling.

Mounting

⚠ Warning

1. Do not put hands or fingers between the plate and cylinder tubing.

Never put hands or fingers in the gap between the plate and cylinder tubing when the piston rods are retracted. Due to the heavy power output of the cylinder, failure to comply with this directive may result in trapping and subsequent injury to the human body.

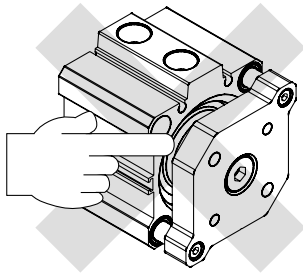

⚠ Caution

1. Do not scratch or dent the sliding parts of the piston rod and guide rods.

Damage to seals may cause air leakage or faulty operation.

2. Mounting of work piece

When screwing a bolt onto the threaded portion of the plate surface, be certain that the guide rods are fully extended to the end.

Also, be careful that the tightening torque is not applied to the guide rods.

Others

⚠ Caution

1. This product should not be used as a stopper.
2. Do not disassemble and modify the product.
3. For example, in a pressing application, the cylinder thrust is directly applied to the plate, therefore, make sure that the pressing force is applied to the plate directly on the extended axial line of a rod. (Below figures.)

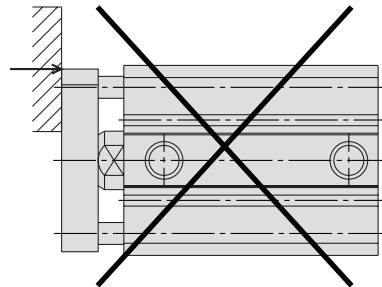
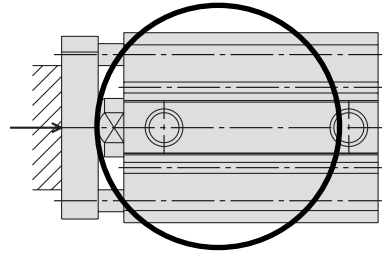

EUROPEAN SUBSIDIARIES:

Austria

SMC Pneumatik GmbH (Austria).
Girakstrasse 8, A-2100 Korneuburg
Phone: +43 2262-62280, Fax: +43 2262-62285
E-mail: office@smc.at
http://www.smc.at

France

SMC Pneumatique, S.A.
1, Boulevard de Strasbourg, Parc Gustave Eiffel
Bussy Saint Georges F-77607 Marne La Vallee Cedex 3
Phone: +33 (0)1-6476 1000, Fax: +33 (0)1-6476 1010
E-mail: contact@smc-france.fr
http://www.smc-france.fr

Netherlands

SMC Pneumatics BV
De Ruyterkade 120, NL-1011 AB Amsterdam
Phone: +31 (0)20-5318888, Fax: +31 (0)20-5318880
E-mail: info@smcpneumatics.nl
http://www.smcpneumatics.nl

Spain

SMC España, S.A.
Zuazobidea 14, 01015 Vitoria
Phone: +34 945-184 100, Fax: +34 945-184 124
E-mail: post@smc.smces.es
http://www.smces.es

Belgium

SMC Pneumatics N.V./S.A.
Nijverheidsstraat 20, B-2160 Wommelgem
Phone: +32 (0)3-355-1464, Fax: +32 (0)3-355-1466
E-mail: post@smcpneumatics.be
http://www.smcpneumatics.be

Germany

SMC Pneumatik GmbH
Boschring 13-15, D-63329 Egelsbach
Phone: +49 (0)6103-4020, Fax: +49 (0)6103-402139
E-mail: info@smc-pneumatik.de
http://www.smc-pneumatik.de

Norway

SMC Pneumatics Norway A/S
Vollsveien 13 C, Granfos Næringspark N-1366 Lysaker
Tel: +47 67 12 90 20, Fax: +47 67 12 90 21
E-mail: post@smc-norge.no
http://www.smc-norge.no

Sweden

SMC Pneumatics Sweden AB
Ekhagsvägen 29-31, S-141 71 Huddinge
Phone: +46 (0)8-603 12 00, Fax: +46 (0)8-603 12 90
E-mail: post@smcpneumatics.se
http://www.smc.nu

Bulgaria

SMC Industrial Automation Bulgaria EOOD
16 kiment Ohridski Blvd., fl.13 BG-1756 Sofia
Phone: +359 2 9744492, Fax: +359 2 9744519
E-mail: office@smc.bg
http://www.smc.bg

Greece

S. Parianosopoulos S.A.
7, Konstantinoupolis Street, GR-11855 Athens
Phone: +30 (0)1-3426076, Fax: +30 (0)1-3455578
E-mail: parianos@hol.gr
http://www.smceu.com

Poland

SMC Industrial Automation Polska Sp.z.o.o.
ul. Konstruktorska 11A, PL-02-673 Warszawa,
Phone: +48 22 548 5085, Fax: +48 22 548 5087
E-mail: office@smc.pl
http://www.smc.pl

Switzerland

SMC Pneumatik AG
Dorfstrasse 7, CH-8484 Weisslingen
Phone: +41 (0)52-396-3131, Fax: +41 (0)52-396-3191
E-mail: info@smc.ch
http://www.smc.ch

Croatia

SMC Industrijska automatika d.o.o.
Cromerec 12, 10000 ZAGREB
Phone: +385 1 377 66 74, Fax: +385 1 377 66 74
E-mail: office@smc.hr
http://www.smceu.com

Hungary

SMC Hungary Ipari Automatizálási Kft.
Budafoki út 107-113, H-1117 Budapest
Phone: +36 1 371 1343, Fax: +36 1 371 1344
E-mail: office@smc-automation.hu
http://www.smc-automation.hu

Portugal

SMC Sucursal Portugal, S.A.
Rua de Engº Ferreira Dias 452, 4100-246 Porto
Phone: +351 22-610-89-22, Fax: +351 22-610-89-36
E-mail: postpt@smc.smces.es
http://www.smces.es

Turkey

Entek Pnömatik San. ve Tic Ltd. Sti.
Perpa Tic. Merkezi Kat: 11 No: 1625, TR-90270 Okmeydanı Istanbul
Phone: +90 (0)212-221-1512, Fax: +90 (0)212-221-1519
E-mail: smc-entek@entek.com.tr
http://www.entek.com.tr

Czech Republic

SMC Industrial Automation CZ s.r.o.
Hudcova 78a, CZ-61200 Brno
Phone: +420 5 414 24611, Fax: +420 5 412 18034
E-mail: office@smc.cz
http://www.smc.cz

Ireland

SMC Pneumatics (Ireland) Ltd.
2002 Citywest Business Campus, Naas Road, Saggart, Co. Dublin
Phone: +353 (0)1-403 9000, Fax: +353 (0)1-464-0500
E-mail: sales@smcpneumatics.ie
http://www.smcpneumatics.ie

Romania

SMC Romania srl
Str Frunzei 29, Sector 2, Bucharest
Phone: +40 213205111, Fax: +40 213261489
E-mail: smcromania@smcromania.ro
http://www.smcromania.ro

UK

SMC Pneumatics (UK) Ltd
Vincent Avenue, Crownhill, Milton Keynes, MK8 0AN
Phone: +44 (0)800 1382930 Fax: +44 (0)1908-555064
E-mail: sales@smcpneumatics.co.uk
http://www.smcpneumatics.co.uk

Denmark

SMC Pneumatik A/S
Knudsminde 4B, DK-8300 Odder
Phone: +45 70252900, Fax: +45 70252901
E-mail: smc@smc-pneumatik.dk
http://www.smc-pneumatik.com

Italy

SMC Italia S.p.A
Via Garibaldi 62, I-20061Carugate, (Milano)
Phone: +39 (0)2-92711, Fax: +39 (0)2-9271365
E-mail: mailbox@smcitalia.it
http://www.smcitalia.it

Russia

SMC Pneumatik LLC.
Sredny pr. 36/40, St. Petersburg 199004
Phone: +812 118 5445, Fax: +812 118 5449
E-mail: marketing@smc-pneumatik.ru
http://www.smc-pneumatik.ru

Estonia

SMC Pneumatics Estonia OÜ
Laki 12-101, 106 21 Tallinn
Phone: +372 (0)6 593540, Fax: +372 (0)6 593541
E-mail: smc@smcpneumatics.ee
http://www.smcpneumatics.ee

Latvia

SMC Pneumatics Latvia SIA
Smerļa 1-705, Rīga LV-1006, Latvia
Phone: +371 (0)777-94-74, Fax: +371 (0)777-94-75
E-mail: info@smclv.lv
http://www.smclv.lv

Slovakia

SMC Priemysel'na' Automatizacia', s.r.o.
Námestie Martina Benku 10, SK-81107 Bratislava
Phone: +421 2 444 56725, Fax: +421 2 444 56028
E-mail: office@smc.sk
http://www.smc.sk

Finland

SMC Pneumatics Finland OY
PL72, Tiistinniityntie 4, SF-02031 ESPOO
Phone: +358 207 513513, Fax: +358 207 513595
E-mail: smcfi@smc.fihttp://www.smc.fi

Lithuania

UAB Ottensten Lietuva
Savanoriu pr. 180, LT-2600 Vilnius, Lithuania
Phone/Fax: +370-2651602

Slovenia

SMC industrijska Avtomatika d.o.o.
Grajski trg 15, SLO-8360 Zuzemberk
Phone: +386 738 85240 Fax: +386 738 85249
E-mail: office@smc-ind-avtom.si
http://www.smc-ind-avtom.si

OTHER SUBSIDIARIES WORLDWIDE:

ARGENTINA, AUSTRALIA, BOLIVIA, BRASIL, CANADA, CHILE,
CHINA, HONG KONG, INDIA, INDONESIA, MALAYSIA, MEXICO,
NEW ZEALAND, PHILIPPINES, SINGAPORE, SOUTH KOREA,
TAIWAN, THAILAND, USA, VENEZUELA

<http://www.smceu.com>
<http://www.smcworld.com>