

SMC Pneumatic Clean Series

Particle generation level of SMC pneumatic clean series equipment can be classified into 1-4 grades by the particle generation measurement test, and each equipment can be used according to the clean room cleanliness class.

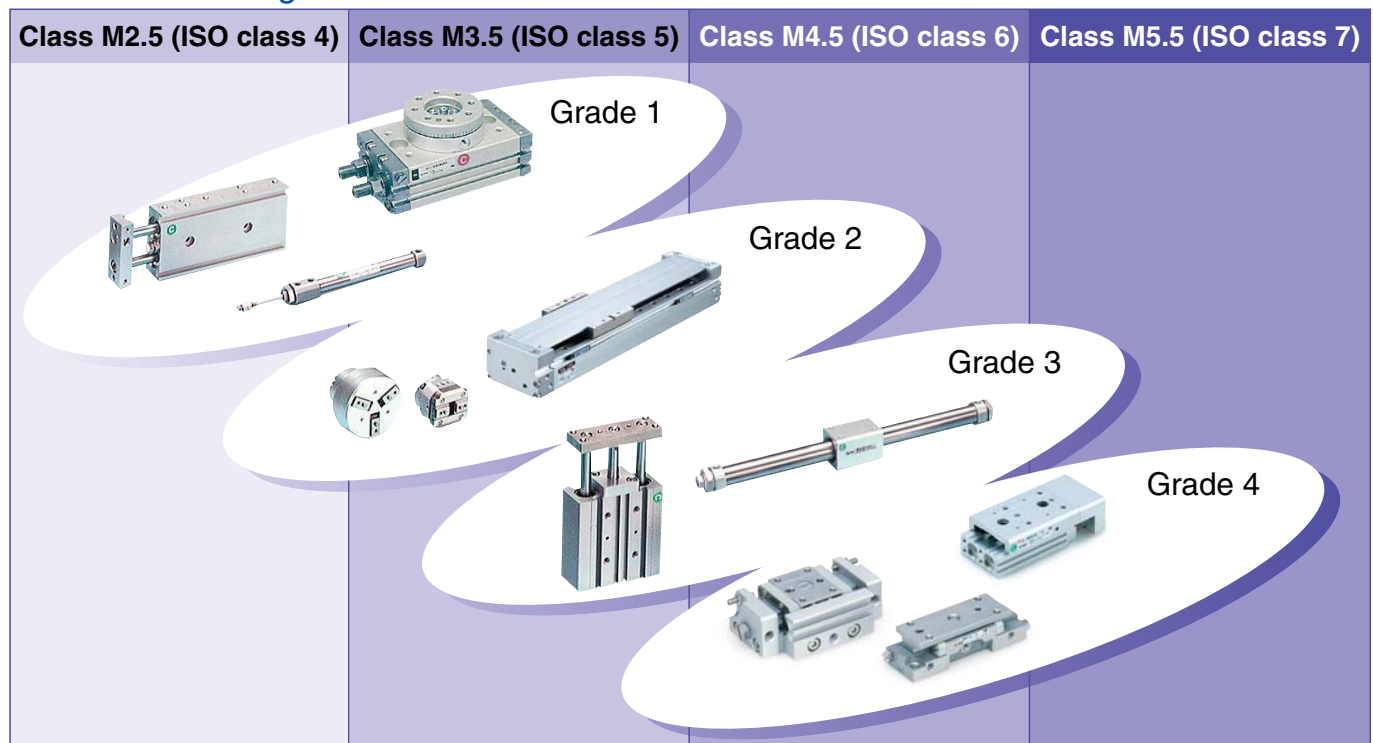

The view above shows an image. Refer to front matter 13 to 22 and the specifications for particle generation grade of each equipment.

Clean Series

Series 10-/11-/12-/13-

Available for clean environment.
Particle generation in a clean room can be prevented.

Applicable model

Actuator, (Air cylinder, Rotary actuator, Air gripper), Directional control valve, Flow control equipment, Filter & Pressure control equipment, Fittings & Tubing, Air preparation equipment, Pressure switch, Clean gas filter

Note) 11-/12-/13- are available only for actuators.

Special Clean Series

Special clean series pursues improvement of cleanliness than the clean series.
This series was developed considering construction, material and assembly environment for use in a clean environment.

Applicable model

Clean rodless cylinder, Clean regulator, Clean one-touch fitting, Clean tubing,
Clean gas filter

Copper, Fluorine, and Silicon free + Low particle generation

Series 21-/22-

For the environment in which the use of copper, fluorine and silicon are restricted.
The same structure as clean series. (Grease and package style are different.)

Applicable model

Actuator (Air cylinder, Rotary actuator, Air gripper), Directional control valve, Flow control equipment, Pressure control equipment, Fittings & Tubing

Note) 22-: Available only for actuators.

Particle generation grade classification

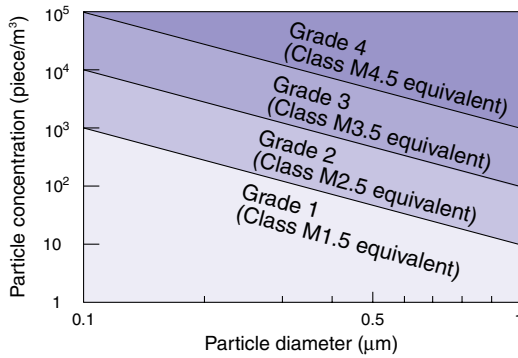

Cleanliness class

SMC	Fed.Std.209E	ISO 14644-1
	SI unit	
Grade 1	M1.5	ISO class 3
Grade 2	M2.5	ISO class 4
Grade 3	M3.5	ISO class 5
Grade 4	M4.5	ISO class 6
	M5.5	ISO class 7
	M6.5	ISO class 8

The grade classification is the SMC original method. The smaller the grade no., the less the particle generation.

The upper concentration limit of the cleanliness class based on Fed. Std. 209E-1992 is shown in parentheses.

(Refer to Front matter 23 "Particle generation measuring method" and Front matter 24 "Comparison of cleanliness standards" for details.)

Note) Do not use one-touch fittings 10-KQ (including solenoid valves with built-in one-touch fittings and speed controllers with one-touch fittings) in Grade 1 or Grade 2 areas because internal pressure change may move the collet chuck slightly, which may cause particle generation. This does not apply to insert fittings (KF), miniature fittings (M, MS), clean one-touch fittings (KP, KPQ, KPG) and speed controllers with clean one-touch fittings (AS-FPQ/FPG).

No dust is carried into the clean room.

After inspection, products are blown with high purity air (clean bench/class M3.5) in a clean environment. Products are sealed and shipped in anti-static double bags.



10-/11-/12-/13- (Clean series.)

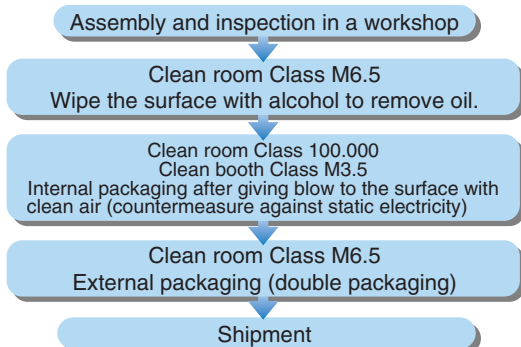

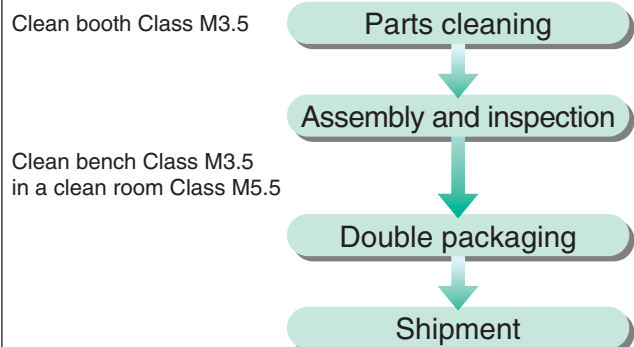

Products assembled in a clean room (Special clean series)





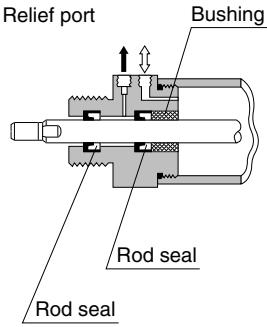
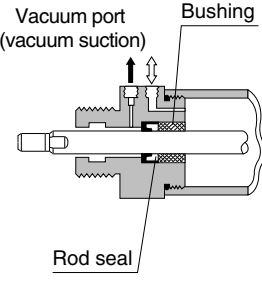

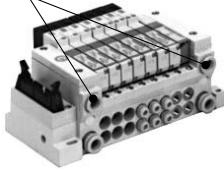

21-/22-series are packed in an usual manner (assembly and inspection in a workshop — packaging — shipment). Please contact SMC for clean packaging.

Basic specifications of actuator

	Series 10-	Series 11-	Series 12-	
Construction	<ul style="list-style-type: none"> • Double seal type / release to atmosphere 	<ul style="list-style-type: none"> • Single seal type / vacuum suction 	<ul style="list-style-type: none"> • Guide cylinder • Dual rod cylinder <p>Double seal type / release to atmosphere (Series 10- equivalent) and specially treated guide</p>  <p>Ball bushing guide Linear guide</p>	<ul style="list-style-type: none"> • Rodless cylinder <p>Specially treated cylinder tube exterior</p>  <p>Cylinder tube</p>
Restricted material	No			
Grease	Fluorine grease			
Assembly environment	General environment (Assembly and inspection in a workshop)			
Packaging style	Clean packaging: Products are sealed in anti-static double bags after giving			

Basic specifications of other equipment

	Series 10-			
Construction	<ul style="list-style-type: none"> • Directional control valve <p>Main valve and pilot valve common exhaust</p>  <ul style="list-style-type: none"> • Pressure control equipment  <p>Relief port With fitting in bleed port</p>	<ul style="list-style-type: none"> • Air filter  <p>Drain guide With female thread</p> <p>Fitting, speed controller, pressure switch, etc. have the same structure as those of standard.</p>	<ul style="list-style-type: none"> • Clean regulator <p>All wetted parts are made of stainless steel, FPM and PTFE, and exterior metal parts are made of anodized aluminum, which provides high corrosion resistance.</p> 	<ul style="list-style-type: none"> • Clean one-touch fittings(for blow)  <p>Wetted part Nonmetal</p> <p>Polypropylene resin</p> <ul style="list-style-type: none"> • Clean tubing <p>Polyolefin Resin</p>
Restricted material	No			
Grease	Fluorine grease		—	—
Assembly environment	General environment (Assembly and inspection in a workshop)		Parts are cleaned and	
Packaging style	Clean packaging: Products are sealed in anti-static double bags after			

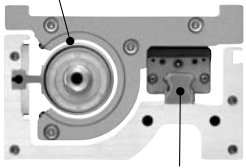
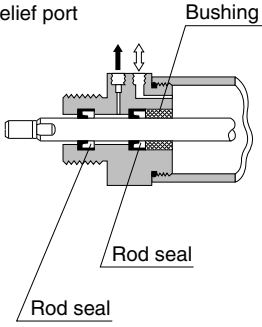
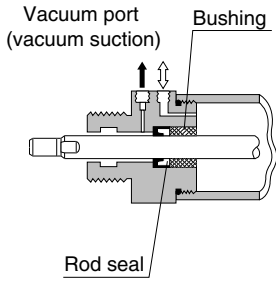
Series 13-	Special clean series	Series 21-	Series 22-
<ul style="list-style-type: none"> • Guide cylinder • Air slide table <p>Single seal type/ vacuum suction (Series 11- equivalent) and specially treated guide</p>  <p>Ball bushing guide Linear guide</p>	<ul style="list-style-type: none"> • Clean rodless cylinder <p>No contact between the cylinder tube exterior and the slider interior</p>  <p>Linear guide Special treatment</p>	<ul style="list-style-type: none"> • Double seal type / release to atmosphere 	<ul style="list-style-type: none"> • Single seal type/ vacuum suction 
	No	Copper, fluorine and silicon-free	
	Fluorine grease	Lithium soap base grease	
	Parts are cleaned and assembled in a clean room.	General environment (Assembly and inspection in a workshop)	
blow to the surface with clean air.		Standard packaging ^(Note)	

Note) Contact SMC for clean packaging.

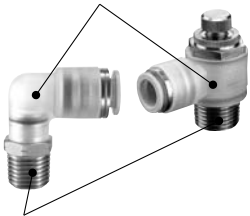
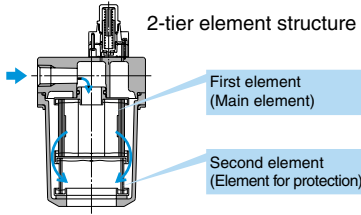
Special clean	Series 21-
<ul style="list-style-type: none"> • Clean one-touch fittings(for drive system air piping) • Clean speed controller <p>Polypropylene resin</p>  <p>Metal part Brass (Electroless nickel plated) or Stainless steel 304</p>	<ul style="list-style-type: none"> • Exhaust cleaner for clean room • Clean gas filter PTFE membrane element  <p>2-tier element structure First element (Main element) Second element (Element for protection)</p> <p>Possible to exhaust in a clean room.</p>
No	<ul style="list-style-type: none"> • Directional control valve • Pressure control equipment • The same construction as Series 10-
Fluorine grease	No seal to the thread parts * Available for uni thread. (Made to Order)
assembled in a clean room.	General environment (Assembly and inspection in a workshop)
giving blow to the surface with clean air.	Parts are cleaned and assembled in a clean room.
	Standard packaging ^(Note)

Note) Contact SMC for clean packaging.

Clean Series INDEX

Cylinder

Air Cylinder		P.2
		
Type	Model	Size
Standard	10-/11-21-/22- CJ2	6, 10, 16
Double rod	10-/11-21-/22- CJ2W	10, 16
Direct mount type	10-/11-21-/22- CJ2RA	

Air Cylinder		P.14
		
Type	Model	Size
Standard	10-/11-21-/22- CM2	20, 25
Double rod	10-/11-21-/22- CM2W	
Direct mount type	10-/11-21-/22- CM2R	32, 40
End lock	10-/11-21-/22- CBM2	

Air Cylinder		P.34
		
Type	Model	Size
Standard	10-/11-21-/22- CG1	20, 25, 32
Double rod	10-/11-21-/22- CG1W	40, 50, 63
Direct mount type	10-/11-21-/22- CG1R	20, 25, 32
		40, 50, 63

Air Cylinder		P.46
		
Model	Size	
10-/11-21-/22- CA2	40, 50, 63	

Mini-free Mount Cylinder		P.50
		
Model	Size	
10-11- CUJ	6, 8, 10	

Free Mount Cylinder		P.53
		
Model	Size	
10-/11-21-/22- CDU	6, 10, 16, 20, 25	

Compact Cylinder		P.56
		
Model	Size	
10-/11-21-/22- CQS	12, 16, 20, 25	

Compact Cylinder		P.64
		
Model	Size	
10-/11-21-/22- CQ2	32, 40, 50, 63, 80, 100	

Sine Cylinder		P.72
		
Model	Size	
10-11- REC	20, 25, 32, 40	

Dual Rod Cylinder		P.76
		
Model	Size	
11-/12-21-/22- CXSJ	6, 10	

Dual Rod Cylinder		P.80
		
Model	Size	
10-/11-/12-21-/22- CXS	6, 10, 15, 20, 25, 32	

Compact Guide Cylinder		P.89
		
Model	Size	
12-/13-21-/22- MGPL	12, 16, 20, 25, 32, 40, 50, 63	

System Circuit in Clean Room

Following are the actuator driving system and circuit configuration of blow system employed to reduce particle generation when using pneumatic equipment in a clean room.

• Actuator driving system

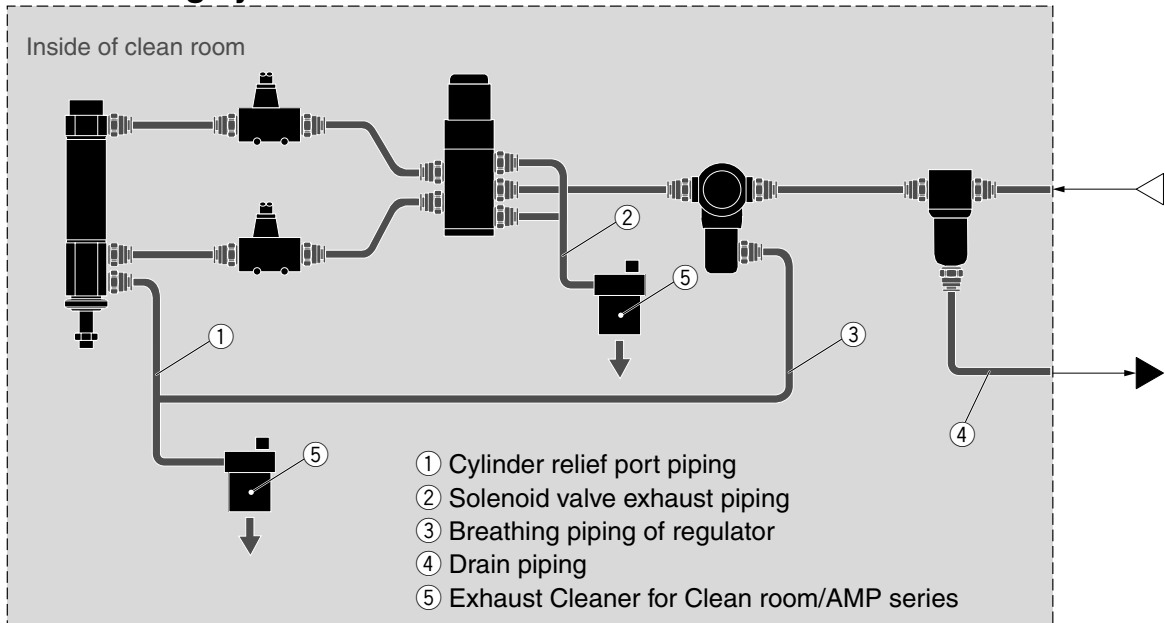

• Cylinder relief port piping

Series 10-/12-/21- (atmospheric release type)

Connect the relief port piping with the dedicated duct piping installed outside the clean room or with the exhaust cleaner for clean room/AMP series.

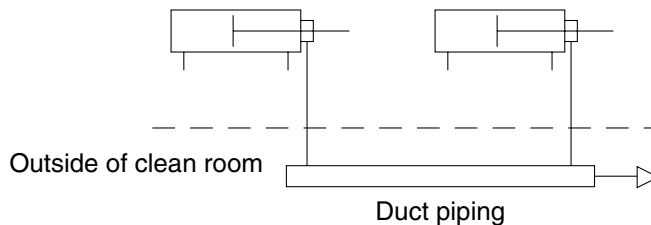

Series 11-/13-/22- (Vacuum suction type)

With a vacuum pump

When several air cylinders are used together or a model with high vacuum suction flow is used.

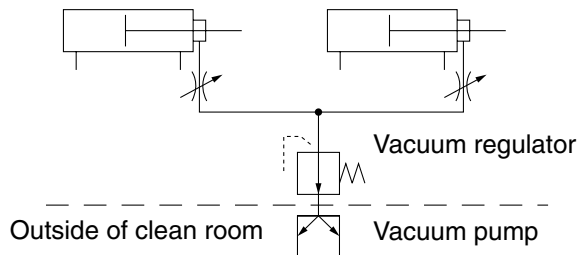

With an ejector

When a few air cylinders are locally used.

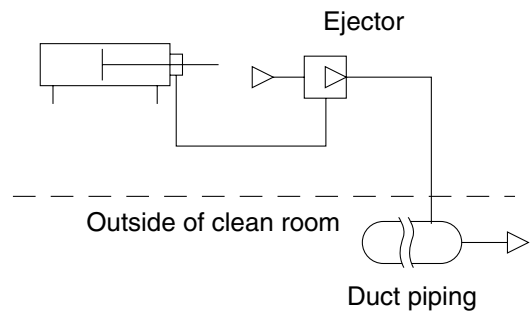

System Circuit in Clean Room

• Clean blow system

Example of equipment to suit each clean blow grade

- Line A: For oil-free air blow
- Line B: For clean blow
- Line C: For clean blow
(With clean gas filter)
- Line D: For N₂ blow

Change in particle generation with time

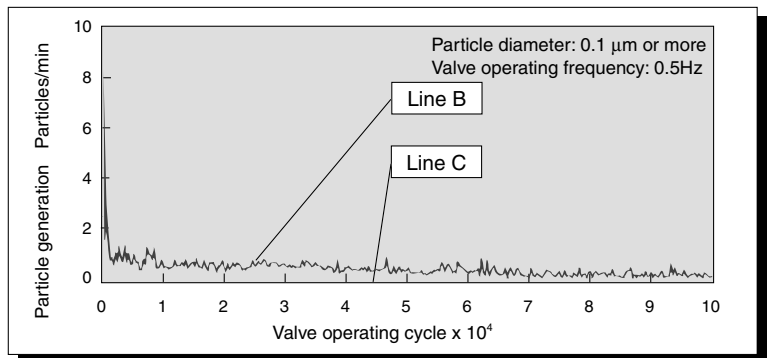
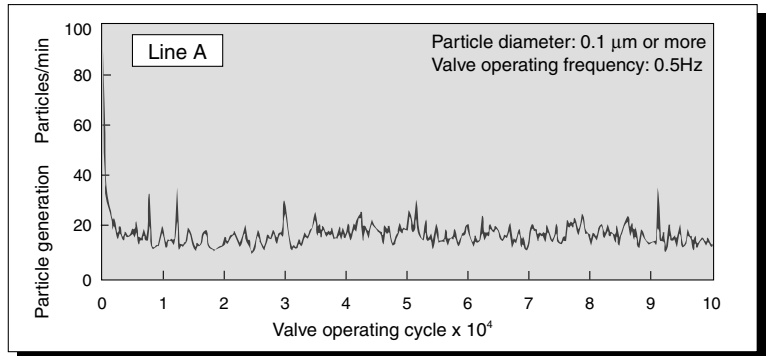

• Example of air line equipment

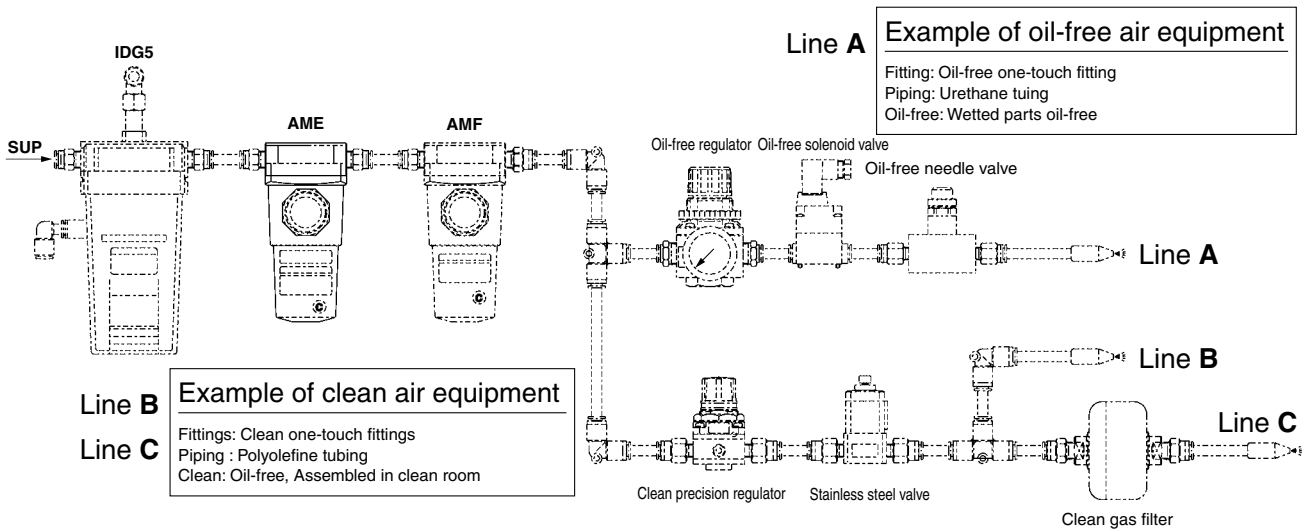

• Example of N₂ equipment

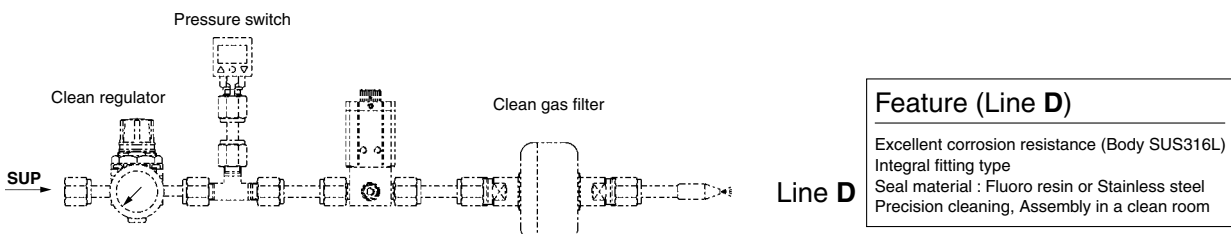

How to Use Clean Series

The position of the pneumatic equipment to the workpiece is determined by the particle generation degree.

$$\boxed{\text{Particle generation grade no. of the pneumatic equipment}} \leq \boxed{\text{The article concentration grade no. around the workpiece}}$$

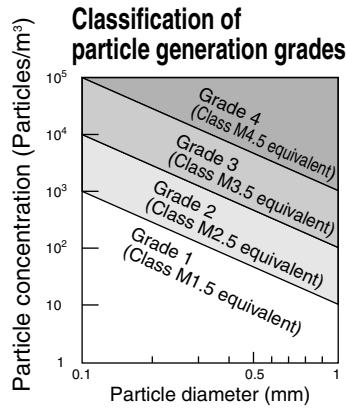

The grade classification is the SMC original method. The smaller the grade number, the less the particle generation. The upper concentration limit of the cleanliness class based on Fed. Std. 209E-1992 is shown in parentheses. (Refer to Front matter 23 "Particle generation measuring method" and Front matter 24 "Comparison of cleanliness standards" for details.)

Note) Do not use one-touch fittings 10-KQ (including solenoid valves with built-in one-touch fittings and speed controllers with one-touch fittings) in Grade 1 or Grade 2 areas because internal pressure change may cause slight move of the collet chuck, which may cause particle generation. This does not apply to insert fittings (KF), miniature fittings (M, MS), clean one-touch fittings (KP, KPQ, KPG) and speed controllers with clean one-touch fittings (AS-FPQ/FPG).

Cleanliness class

SMC	Fed.Std.209E	ISO 14644-1
	SI unit	
Grade 1	M1.5	ISO class 3
Grade 2	M2.5	ISO class 4
Grade 3	M3.5	ISO class 5
Grade 4	M4.5	ISO class 6
-	M5.5	ISO class 7
-	M6.5	ISO class 8

Selection procedure

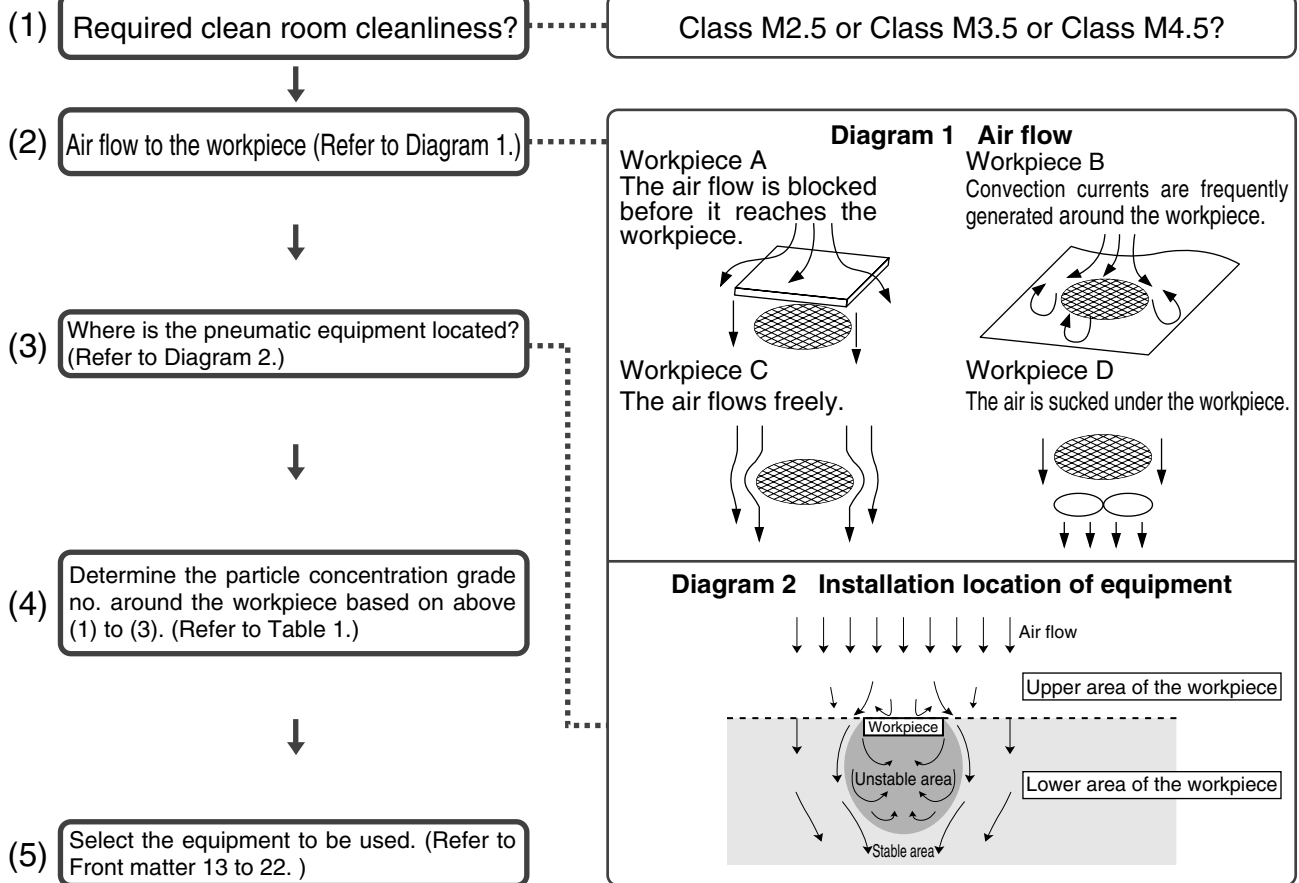













Table 1 Particle concentration grade around the workpiece

(2) Workpiece		A,B			C			D		
		Upper area of the workpiece	Lower area of the workpiece		Upper area of the workpiece	Lower area of the workpiece		Upper area of the workpiece	Lower area of the workpiece	
	Unstable area		Stable area	Unstable area		Stable area	Unstable area		Stable area	
(1) Cleanliness	Class M2.5				Grade 1	Grade 2		Grade 1	Grade 2	
	Class M3.5					Grade 2	Grade 3			Grade 3
	Class M4.5	Grade 1	Grade 2	Grade 3	Grade 2	Grade 3	Grade 4	Grade 2	Grade 3	Grade 4

: Class M2.5 and M3.5 levels of cleanliness cannot be achieved in area due to dust accumulation or flotation.

Particle Generation Grade

Cylinder

Description			Model	Particle generation grade by series						
				Standard	10-	11-	12-	13-	21-	22-
	Air Cylinder	Standard	10-/11- 21-/22- CJ2	3	2	1			2	1
		Double rod	10-/11- 21-/22- CJ2W							
		Direct mount type	10-/11- 21-/22- CJ2RA							
	Air Cylinder	Standard	10-/11- 21-/22- CM2	3	2	1			3	1
		Double rod	10-/11- 21-/22- CM2W							
		Direct mount type	10-/11- 21-/22- CM2R							
		End lock	10-/11- 21-/22- CBM2							
	Air Cylinder	Standard	10-/11- 21-/22- CG1	3	2	1			3	1
		Double rod	10-/11- 21-/22- CG1W							
		Direct mount type	10-/11- 21-/22- CG1R							
	Air Cylinder Standard		10-/11- 21-/22- CA2	3	2	1			3	1
	Mini-free Mount Cylinder		10- 11- CUJ	3	2	1				
	Free Mount Cylinder		10-/11- 21-/22- CDU	3	2	1			3	1
	Compact Cylinder		10-/11- 21-/22- CQS	3	2	1			2	1
			10-/11- 21-/22- CQ2	3	2	1			2	1
	Sine Cylinder		10- 11- REC	3	2	1				
	Dual Rod Cylinder		11-/12- 21-/22- CXSJ	3, 4 ^{Note)}		1	2		3	1
			10-/11-/12- 21-/22- CXS	3, 4 ^{Note)}	2	1	2		3	1

Note) Grade is different depending on the type of the ball bearing.

Values in show grades.

No grade applies to the blanks.

CXSJ

Model	Bearing type	Standard
CXSJL	Ball bushing bearing	3
CXSJM	Slide bearing	4

CXS

Model	Bearing type	Standard
CXSL	Ball bushing bearing	3
CXSM	Slide bearing	4

Particle Generation Measuring Method

The particle generation data for SMC CLEAN SERIES are measured in the following test method.

Test method (Example)

Place the specimen in the acrylic resin chamber and operate it while supplying the same flow rate of clean air as the suction flow rate of the measuring instrument (15ℓ/min). Measure the changes of the particle concentration over time until the number of cycles reaches the specified point. The chamber is placed in a Class M3.5 clean bench.

Measuring conditions

Chamber	Internal volume	15ℓ
	Supply air quality	Same quality as the supply air for driving
Measuring instrument	Description	Laser dust monitor (Automatic particle counter by light-scattering method)
	Model no.	TS-1500
	Minimum measurable particle diameter	0.17μm
	Suction flow rate	15ℓ/min
	Manufacturer	Hitachi Electronics Engineering Co. Ltd.
Setting conditions	Sampling time	5min
	Interval time	55min
	Sampling air flow	75ℓ

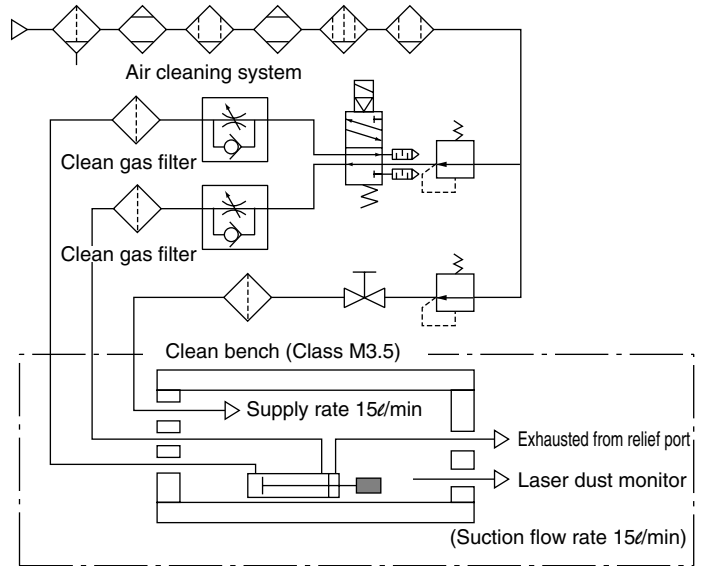

Particle generation measuring circuit

Evaluation method

To obtain the measured values of particle concentration, the accumulated value ^{Note 1)} of particles captured every 5 minutes, by the laser dust monitor, is converted into the particle concentration in every 1m³.

When determining particle generation grades, the 95% upper confidence limit of the average particle concentration (average value), when each specimen is operated at a specified number of cycles ^{Note 2)} is considered.

The plots in the graphs indicate the 95% upper confidence limit of the average particle concentration of particles with a diameter within the horizontal axis range.

Note 1) Sampling air flow rate: Number of particles contained in 75ℓ of air

Note 2) Actuator: 1 million cycles

Solenoid valve: 2 million cycles

Particle generation characteristics of CM2

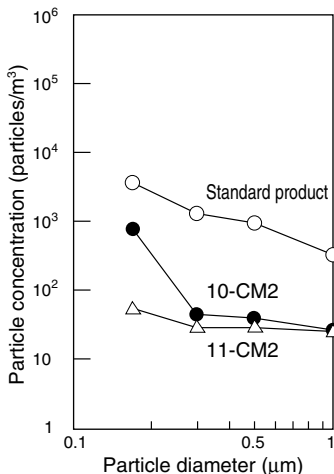

Particle generation characteristics of CXSL

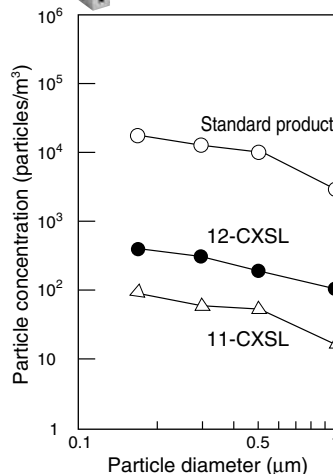

Particle generation characteristics of CY1B

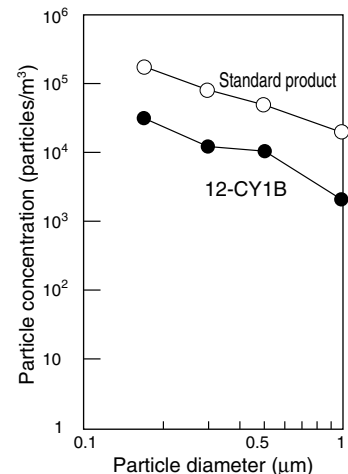

Comparison of Cleanliness Standards

Standard	Fed.Std.209E	ISO 14644-1	
Cleanliness classes	British unit: Class 1 to 100.000 SI unit: Class M1 to M7 U descriptor: Particles diameter smaller than 0.1 µm	ISO Cass 1 to 9 Intermediate classes available U descriptor: Particles smaller than 0.1 µm M descriptor: Particles larger than 5.0 µm	
	(British unit)	(SI unit)	
			ISO Class 1
			ISO Class 2
	1	M1.5	ISO Class 3
	10	M2.5	ISO Class 4
	100	M3.5	ISO Class 5
	1000	M4.5	ISO Class 6
	10000	M5.5	ISO Class 7
100000	M6.5	ISO Class 8	
		ISO Class 9	
Cleanliness class indication	The number of particles diameter larger than 0.5 µm in an air volume of 1m ³ is expressed in 10M or coefficient Nc. Cleanliness class: Nc or M	The number of particles larger than 0.1 µm in an air volume of 1m ³ is expressed in 10 ^N . ISO Class N: Occupancy state: Considered particle size	
Calculation of the maximum permitted concentration of particulate cleanliness classes	British unit: Number of particles/ft ³ = Nc x (0.5/D) ²² SI unit: Number of particles/m ³ = 10M x (0.5/D) ²²	Cn = 10 ^N x (0.1/D) ^{2.08}	
Evaluation method using a simple sampling	① Number of sampling locations: 2 to 9 95% UCL of the mean and the mean of the averages ② Number of sampling locations: 10 or more The mean	① Number of sampling locations: 2 to 9 95% UCL of the mean and the mean of the averages ② Number of sampling locations: 1, or 10 or more The mean	
Number of sampling locations	① Non-unidirectional airflow: at least two locations N _L = A x 64/(10M) ^{0.5} ② Unidirectional airflow: at least two locations Smaller value between N _L =A/2.32 and N _L =A x 64/(10M) ^{0.5}	Derive it from the area of the cleanroom or clean air controlled space. The number of sampling locations N _L = (A) ^{0.5} At least one location	
Min. sampling air flow volume	2 liters or a sufficient volume of air that a minimum of 20 particles could be counted if the particle concentration were at the class limit.	2 liters or a sufficient volume of air that a minimum of 20 particles could be counted if the particle concentration were at the class limit. Min. sampling time: 1 minute	
Number of samplings	Total number of samplings in each clean zone: 5 times or more	Where only one sampling location is required, take a minimum of three single sample volumes at that location.	
Sampling method	5.0 µm and larger: Constant velocity and suction in the same direction of the air flow 0.5 to 5 µm: Correction possible when it is sucked at a nonconstant velocity	Suction in the same direction as the airflow If the direction of the airflow is not predictable, the inlet of the sampling probe shall be directed vertically upward.	

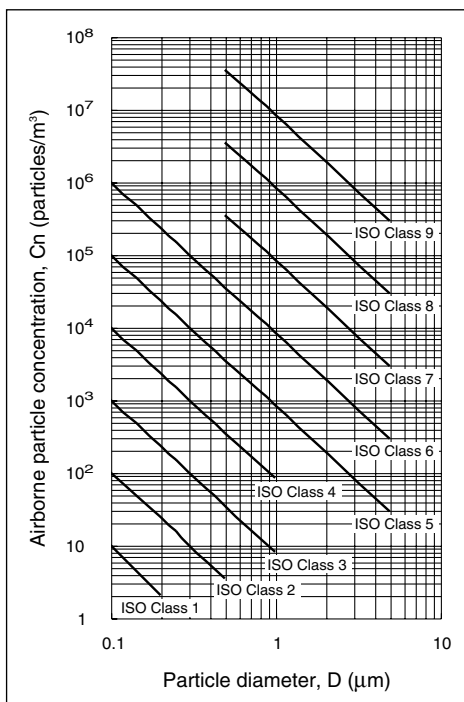

Cleanliness class (N)	Maximum concentration limit (particles/m ³)						
	Considered particle diameter (µm)						
	0.1	0.2	0.3	0.5	1	5	
ISO Class	1	10	2				
	2	100	24	10	4		
	3	1000	237	102	35	8	
	4	10000	2370	1020	352	83	
	5	100000	23700	10200	3520	832	29
	6	1000000	237000	102000	35200	8320	293
	7				352000	83200	2930
	8				3520000	832000	29300
	9				35200000	8320000	293000

Note) Concentration data with no more than three significant figures be used in determining the classification level.

$$C_n = 10^N \times (0.1/D)^{2.08}$$

C_n: The maximum permitted concentration of airborne particles that are equal to or larger than the considered particle size (D). C_n is rounded down to the nearest whole number, using no more than three significant figures.

N: Class no.(1 to 9), intermediate class (1.1 to 8.9)

D: Measured particle diameter (µm)

0.1: Constant number (µm)

Series 10-11-REC

Sine Cylinder / ø20, ø25, ø32, ø40

How to Order



10 - R E C L 25 - 150 - H7B

● Clean series

10	Relief type
11	Vacuum suction type

● Mounting style

B	Basic style
L	Axial foot style
F	Rod side flange style
G	Head side flange style

● Bore size (mm)

20	25	32	40
----	----	----	----

● Port type

Nil	Rc
TN	NPT
TF	G

● Cylinder stroke (mm)

100	150	200	250	300	350	400	450	500
-----	-----	-----	-----	-----	-----	-----	-----	-----

● Number of auto switches

Nil	2 pcs.
S	1 pc.
n	n pcs.

● Type of auto switch

Reed switch	C73
Solid state switch	H7B,H7NW

Model

	Model	Bore size (mm)	Port size	Lubrication	Action	Standard stroke (mm)	Auto switch mounting	Cushion	Effective cushioning stroke (mm)	
Relief type	10-REC□20	20	1/8	Non-lube	Double acting single rod	150 to 700	○	Air cushion (Both sides)	45	
	10-REC□25	25								
	10-REC□32	32	1/4			150 to 1000				60
	10-REC□40	40								
Vacuum suction type	11-REC□20	20	1/8			150 to 700			45	
	11-REC□25	25								
	11-REC□32	32	1/4			150 to 1000			50	
	11-REC□40	40								200 to 1000

Specifications

Item	Bore size (mm)
	20/25/32/40
Proof pressure	1.5MPa
Maximum operating pressure	1.0MPa
Minimum operating pressure	0.2MPa
Ambient and fluid temperature	-10°C to 60°C (With no freezing)
Piston speed	50 to 400mm/s
Cushion	Air cushion
Stroke length tolerance	to 250ST: $^{+1.0}_0$, 251 to 1,000ST: $^{+1.4}_0$
Mounting style	Basic style / Axial foot style / Rod side flange style / Head side flange style
Grease	Fluorine grease
Particle generation grade	10-: Grade 2
(Refer to front matter pages 13 to 22 for details.)	11-: Grade 1

Suction flow rate of vacuum suction type (Reference values)

Size	Suction flow rate l/min (ANR)
20	1
25/32/40	2

Auto switch specifications (Refer to Best Pneumatics catalog for detailed specifications and auto switches not in the following table.)

Style	Auto switch part no.	Load voltage	Load current range	Indicator light	Application
Reed switch	D-C73	24 VDC, 100 VAC	5 to 40mA, 5 to 20mA	○	Relay, PLC
Solid state switch	2-wire type D-H7B	24 VDC (10 to 28 VDC)	5 to 40mA	○	24 VDC, PLC
	3-wire type D-H7NW	28 VDC or less	40mA or less	○	IC circuit, Relay, PLC

Refer to applicable auto switch list — Page 182.

PLC: Programmable Logic Controller

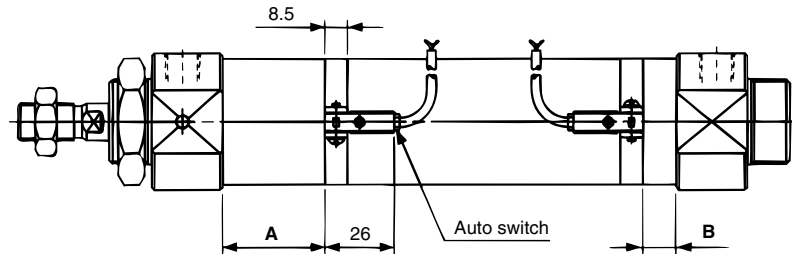
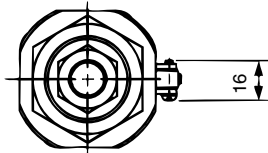
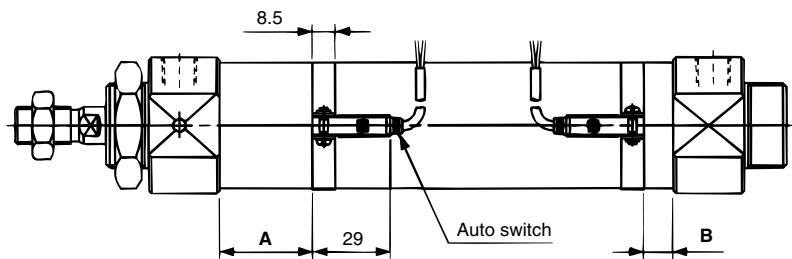
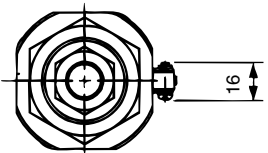
Auto switches / Proper mounting position for stroke end detection**D-C73****D-H7B / H7NW**

(mm)

Bore size	D-C73		D-H7B, D-H7NW	
	A	B	A	B
20	56.0	31.0	55.0	30.0
25	56.0	31.0	55.0	30.0
32	59.5	36.5	58.5	35.5
40	70.0	39.0	69.0	38.0

Note) The above-mentioned values are indicated as a guide for auto switch mounting position for stroke end detection. When actually mounting an autoswitch, adjust the position after confirming the operating state of the auto switch.

**Specific Product Precautions**

Be sure to read before handling.

Speed adjustment**⚠ Caution**

1. Throttle speed controller, such as Series AS, is recommended for speed adjustment.

Recommended speed controllers

Model	Model		
	Elbow type	Straight type	In-line type
⚠: REC20	10-AS2201F-01-06-X214	10-AS2301F-01-06-X214	10-AS2001F-06-X214
⚠: REC25	10-AS2201F-01-06-X214	10-AS2301F-01-06-X214	10-AS2001F-06-X214
⚠: REC32	10-AS2201F-01-06-X214	10-AS2301F-01-06-X214	10-AS3001F-08-X214
⚠: REC40	10-AS3201F-02-08-X214	10-AS3301F-02-08-X214	10-AS3001F-08-X214

2. Speed control is possible with meter-in and meter-out styles of speed controllers. However, smooth acceleration and deceleration may not be obtained by these speed controllers.
3. For installation other than horizontal mounting, it is recommended to use a system with reduced pressure supply circuit on the downward side. (This system is also effective for a start delay at rise and air reduction.)

Cushion adjustment**⚠ Caution**

1. Cushion adjustment mechanism is not provided. Cushion adjustment is not necessary because the model can perform smooth acceleration and deceleration in a wide range of strokes without an adjusting cushion.

Relief Port**⚠ Caution**

1. Hexagon socket set screw is not prepared for clean room specifications, and use it as relieving port accordingly.

Dimensions

Basic style (B) / ¹⁰/₁₁-RECB

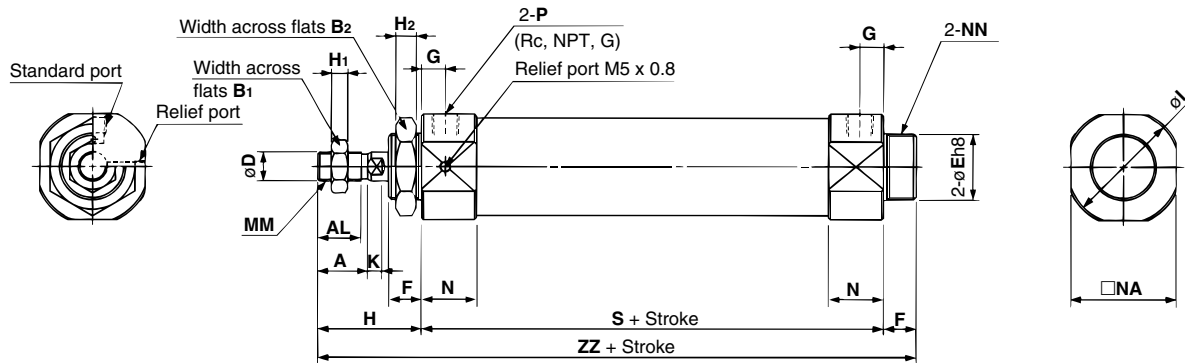

Bore size	Stroke range	A	AL	B ₁	B ₂	D	E	F	G	H	H ₁	H ₂	I	K	MM	N	NA	NN	P	S	ZZ
20	150 to 700	18	15.5	13	26	8	20 ⁰ _{-0.033}	13	10	41	5	8	33.5	5	M8 x 1.25	20	30	M20 x 1.5	1/8	146	200
25	150 to 700	22	19.5	17	32	10	26 ⁰ _{-0.033}	13	10	45	6	8	37.5	5.5	M10 x 1.25	20	34.5	M26 x 1.5	1/8	146	204
32	150 to 1000	22	19.5	17	32	12	26 ⁰ _{-0.033}	13	11	45	6	8	46.5	5.5	M10 x 1.25	22	42.5	M26 x 1.5	1/8	159	217
40	200 to 1000	24	21	22	41	14	32 ⁰ _{-0.039}	16	12.5	50	8	10	56.2	7	M14 x 1.5	26.5	51	M32 x 2	1/4	181	247

Axial foot style (L): ¹⁰/₁₁-RECL

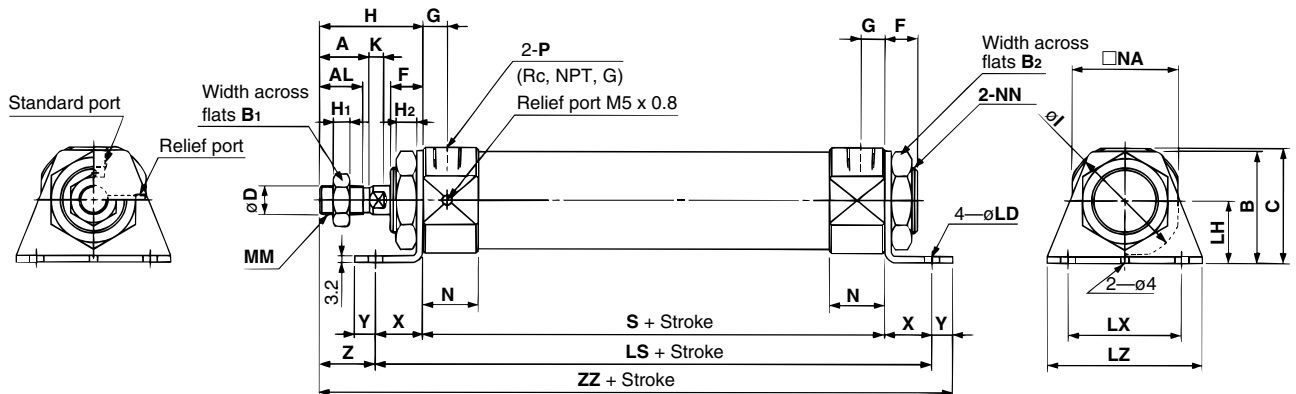

Bore size	Stroke range	A	AL	B	B ₁	B ₂	C	D	F	G	H	H ₁	H ₂	I	K	LD	LH	LS	LX	LZ	MM	N	NA
20	150 to 700	18	15.5	40	13	26	40	8	13	10	41	5	8	33.5	5	6.8	25	186	40	55	M8 x 1.25	20	30
25	150 to 700	22	19.5	47	17	32	45.5	10	13	10	45	6	8	37.5	5.5	6.8	28	186	40	55	M10 x 1.25	20	34.5
32	150 to 1000	22	19.5	47	17	32	49.5	12	13	11	45	6	8	46.5	5.5	6.8	28	199	40	55	M10 x 1.25	22	42.5
40	200 to 1000	24	21	54	22	41	55.5	14	16	12.5	50	8	10	56.2	7	7	30	227	55	75	M14 x 1.5	26.5	51

Bore size	Stroke range	NN	P	S	X	Y	Z	ZZ
20	150 to 700	M20 x 1.5	1/8	146	20	8	21	215
25	150 to 700	M26 x 1.5	1/8	146	20	8	25	219
32	150 to 1000	M26 x 1.5	1/8	159	20	8	25	232
40	200 to 1000	M32 x 2	1/4	181	23	10	27	264

Rod side flange style (F) / 10-RECF

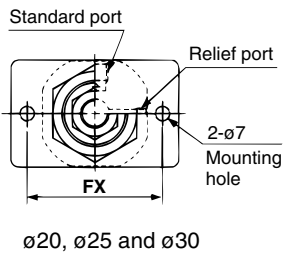
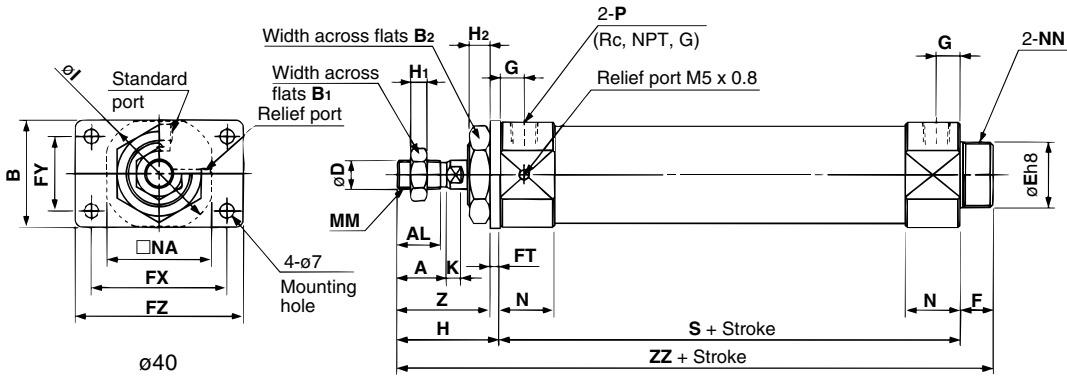

Bore size	Stroke range	A	AL	B	B ₁	B ₂	D	E	F	FT	FX	FY	FZ	G	H
20	150 to 700	18	15.5	34	13	26	8	20 ⁰ _{-0.033}	13	4	60	—	75	10	41
25	150 to 700	22	19.5	40	17	32	10	26 ⁰ _{-0.033}	13	4	60	—	75	10	45
32	150 to 1000	22	19.5	40	17	32	12	26 ⁰ _{-0.033}	13	4	60	—	75	11	45
40	200 to 1000	24	21	52	22	41	14	32 ⁰ _{-0.039}	16	5	66	36	82	12.5	50

Bore size	Stroke range	H ₁	H ₂	I	K	MM	N	NA	NN	P	S	Z	ZZ
20	150 to 700	5	8	33.5	5	M8 x 1.25	20	30	M20 x 1.5	1/8	146	37	200
25	150 to 700	6	8	37.5	5.5	M10 x 1.25	20	34.5	M26 x 1.5	1/8	146	41	204
32	150 to 1000	6	8	46.5	5.5	M10 x 1.25	22	42.5	M26 x 1.5	1/8	159	41	217
40	200 to 1000	8	10	56.2	7	M14 x 1.5	26.5	51	M32 x 2	1/4	181	45	247

Head side flange style (G) / 10-RECG

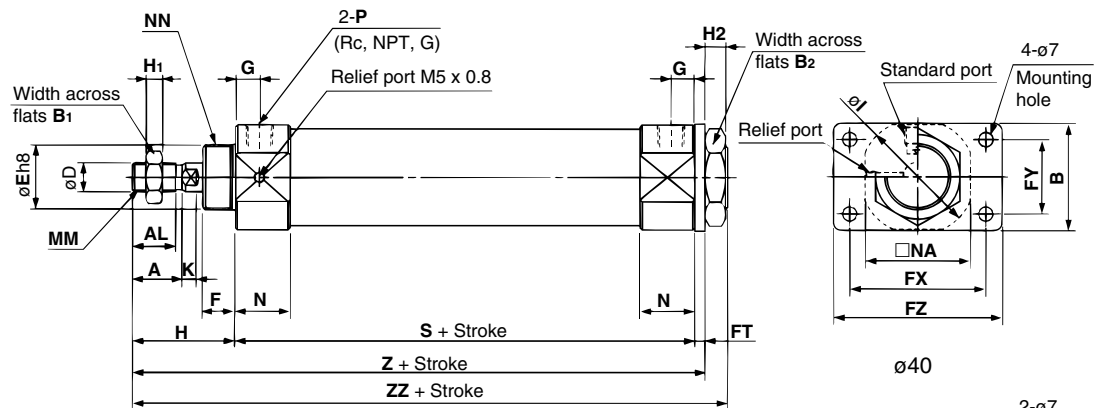

Bore size	Stroke range	A	AL	B	B ₁	B ₂	D	E	F	FT	FX	FY	FZ	G	H
20	15 to 700	18	15.5	34	13	26	8	20 ⁰ _{-0.033}	13	4	60	—	75	10	41
25	150 to 700	22	19.5	40	17	32	10	26 ⁰ _{-0.033}	13	4	60	—	75	10	45
32	150 to 1000	22	19.5	40	17	32	12	26 ⁰ _{-0.033}	13	4	60	—	75	11	45
40	200 to 1000	24	21	52	22	41	14	32 ⁰ _{-0.039}	16	5	66	36	82	12.5	50

Bore size	Stroke range	H ₁	H ₂	I	K	MM	N	NA	NN	P	S	Z	ZZ
20	150 to 700	5	8	33.5	5	M8 x 1.25	20	30	M20 x 1.5	1/8	146	191	200
25	150 to 700	6	8	37.5	5.5	M10 x 1.25	20	34.5	M26 x 1.5	1/8	146	195	204
32	150 to 1000	6	8	46.5	5.5	M10 x 1.25	22	42.5	M26 x 1.5	1/8	159	208	217
40	200 to 1000	8	10	56.2	7	M14 x 1.5	26.5	51	M32 x 2	1/4	181	236	247

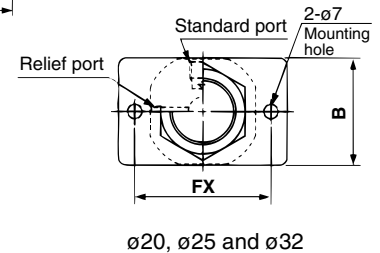





Safety Instructions

These safety instructions are intended to prevent hazardous situations and/or equipment damage. These instructions indicate the level of potential hazard with the labels of “**Caution,**” “**Warning**” or “**Danger.**” They are all important notes for safety and must be followed in addition to International Standards (ISO/IEC), Japan Industrial Standards (JIS)*1) and other safety regulations*2).

- * 1) ISO 4414: Pneumatic fluid power – General rules relating to systems.
ISO 4413: Hydraulic fluid power – General rules relating to systems.
IEC 60204-1: Safety of machinery – Electrical equipment of machines. (Part 1: General requirements)
ISO 10218-1992: Manipulating industrial robots -Safety.
JIS B 8370: General rules for pneumatic equipment.
JIS B 8361: General rules for hydraulic equipment.
JIS B 9960-1: Safety of machinery – Electrical equipment of machines. (Part 1: General requirements)
JIS B 8433-1993: Manipulating industrial robots - Safety.
etc.
- * 2) Labor Safety and Sanitation Law, etc.

 **Caution:** Operator error could result in injury or equipment damage.

 **Warning:** Operator error could result in serious injury or loss of life.

 **Danger :** In extreme conditions, there is a possibility of serious injury or loss of life.

Warning

1. The compatibility of the product is the responsibility of the person who designs the equipment or decides its specifications.

Since the product specified here is used under various operating conditions, its compatibility with specific equipment must be decided by the person who designs the equipment or decides its specifications based on necessary analysis and test results. The expected performance and safety assurance of the equipment will be the responsibility of the person who has determined its compatibility with the product. This person should also continuously review all specifications of the product referring to its latest catalog information, with a view to giving due consideration to any possibility of equipment failure when configuring the equipment.

2. Only personnel with appropriate training should operate machinery and equipment.

The product specified here may become unsafe if handled incorrectly. The assembly, operation and maintenance of machines or equipment including our products must be performed by an operator who is appropriately trained and experienced.

3. Do not service or attempt to remove product and machinery/equipment until safety is confirmed.

1. The inspection and maintenance of machinery/equipment should only be performed after measures to prevent falling or runaway of the driven objects have been confirmed.

2. When the product is to be removed, confirm that the safety measures as mentioned above are implemented and the power from any appropriate source is cut, and read and understand the specific product precautions of all relevant products carefully.

3. Before machinery/equipment is restarted, take measures to prevent unexpected operation and malfunction.

4. Contact SMC beforehand and take special consideration of safety measures if the product is to be used in any of the following conditions.

1. Conditions and environments outside of the given specifications, or use outdoors or in a place exposed to direct sunlight.

2. Installation on equipment in conjunction with atomic energy, railways, air navigation, space, shipping, vehicles, military, medical treatment, combustion and recreation, or equipment in contact with food and beverages, emergency stop circuits, clutch and brake circuits in press applications, safety equipment or other applications unsuitable for the standard specifications described in the product catalog.

3. An application which could have negative effects on people, property, or animals requiring special safety analysis.

4. Use in an interlock circuit, which requires the provision of double interlock for possible failure by using a mechanical protective function, and periodical checks to confirm proper operation.



Safety Instructions

Caution

The product is provided for use in manufacturing industries.

The product herein described is basically provided for peaceful use in manufacturing industries.

If considering using the product in other industries, consult SMC beforehand and exchange specifications or a contract if necessary. If anything is unclear, contact your nearest sales branch.

Limited Warranty and Disclaimer/Compliance Requirements

The product used is subject to the following “Limited Warranty and Disclaimer” and “Compliance Requirements”. Read and accept them before using the product.

Limited Warranty and Disclaimer

1. The warranty period of the product is 1 year in service or 1.5 years after the product is delivered.*3)

Also, the product may have specified durability, running distance or replacement parts. Please consult your nearest sales branch.

2. For any failure or damage reported within the warranty period which is clearly our responsibility, a replacement product or necessary parts will be provided.

This limited warranty applies only to our product independently, and not to any other damage incurred due to the failure of the product.

3. Prior to using SMC products, please read and understand the warranty terms and disclaimers noted in the specified catalog for the particular products.

* 3) Vacuum pads are excluded from this 1 year warranty.

A vacuum pad is a consumable part, so it is warranted for a year after it is delivered.

Also, even within the warranty period, the wear of a product due to the use of the vacuum pad or failure due to the deterioration of rubber material are not covered by the limited warranty.

Compliance Requirements

When the product is exported, strictly follow the laws required by the Ministry of Economy, Trade and Industry (Foreign Exchange and Foreign Trade Control Law).



Clean series: Common Precautions 1

Be sure to read before handling.

Refer to the main text for detailed precautions on every series.

Air Supply

Caution

System Configuration

Refer to the "Air Preparation System" below for the quality of compressed air before configuring the system.

Main line

Sub-line

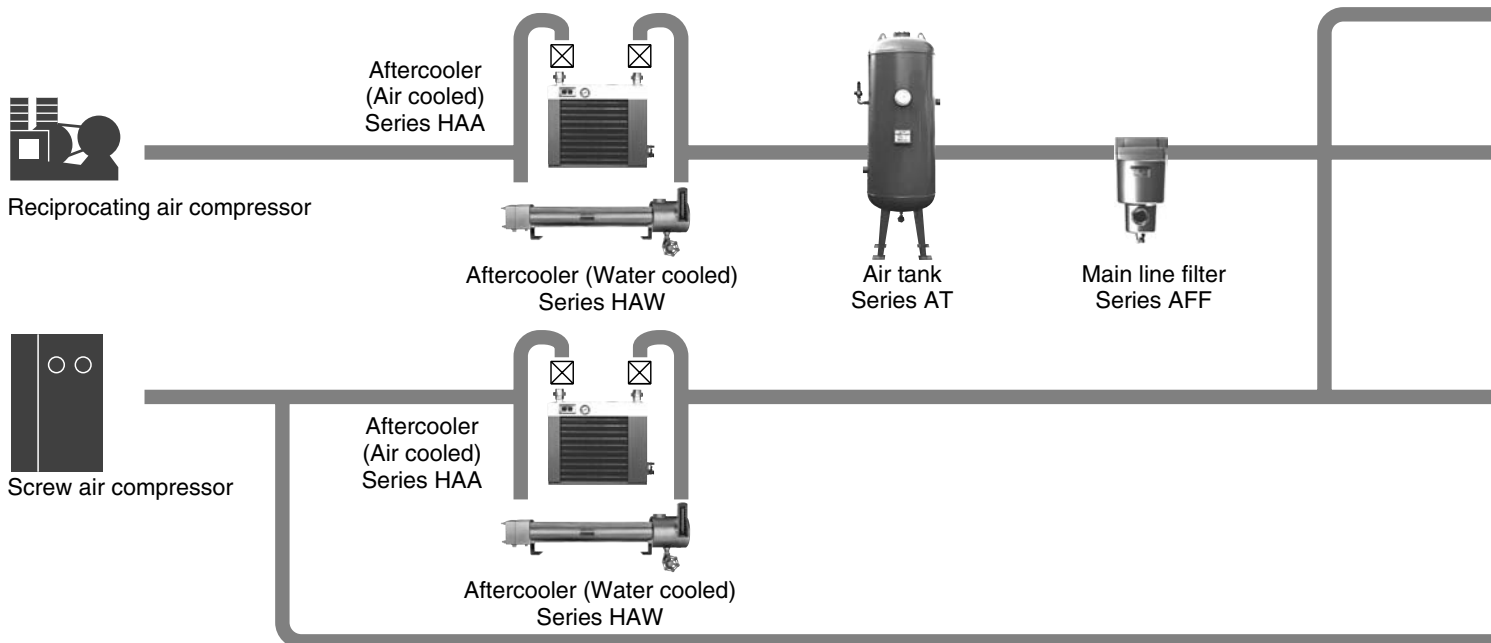

Piping

1. Provide an inclination of 1cm per meter in the direction of the air flow to the main piping.
2. If there is a line branching from the main piping, provide an outlet of compressed air on top using a tee so that drainage accumulated in the piping will not flow out.
3. Provide a drainage mechanism at every recessed point or dead end to prevent drain accumulation.
4. For future piping extensions, plug the end of the piping with a tee.
5. Before piping
Before piping, the piping should be thoroughly blown out with air (flushed) or washed to remove chips, cutting oil and other debris from inside the pipe.
6. Wrapping of pipe tape
When screwing piping or fittings into ports, ensure that chips from the pipe threads or sealing material do not get inside the valve. Also, when pipe tape is used, leave 1.5 to 2 thread ridges exposed at the end of the threads.

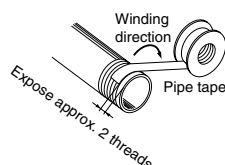

7. If air with a low dew point (-40°C or less) is required, do not use nylon tube or resin fitting (except for fluorine resin) for the outlet side of the membrane air dryer or heatless air dryer. Nylon tubing could be affected by the ambient air and it thus might not be possible to achieve the prescribed low dew point at the end of the tube. Therefore, for low dew point air, use stainless steel or fluorine tube.

Maintenance

1. If the heatless air dryer Series ID is left unused for a long period, the absorbent may be moistened. Prior to use, close the valve on the outlet side of the dryer for regeneration and drying.

Caution on Design

Employ a safe design, so that the following unexpected conditions will not occur.

Warning

1. Provide a design that prevents high-temperature compressed air from flowing into the outlet side of the cooling equipment.
If the flow of the coolant water in a water-cooled aftercooler is stopped or if the fan motor of an air cooled aftercooler is stopped, the high-temperature compressed air will flow to the outlet side of the cooling equipment, causing the equipment on the outlet side (such as the AFF, AM, AD, or IDF series) to be damaged or to malfunction.
2. Provide a design in which interruptions in the supply of compressed air are taken into consideration.

Air Supply

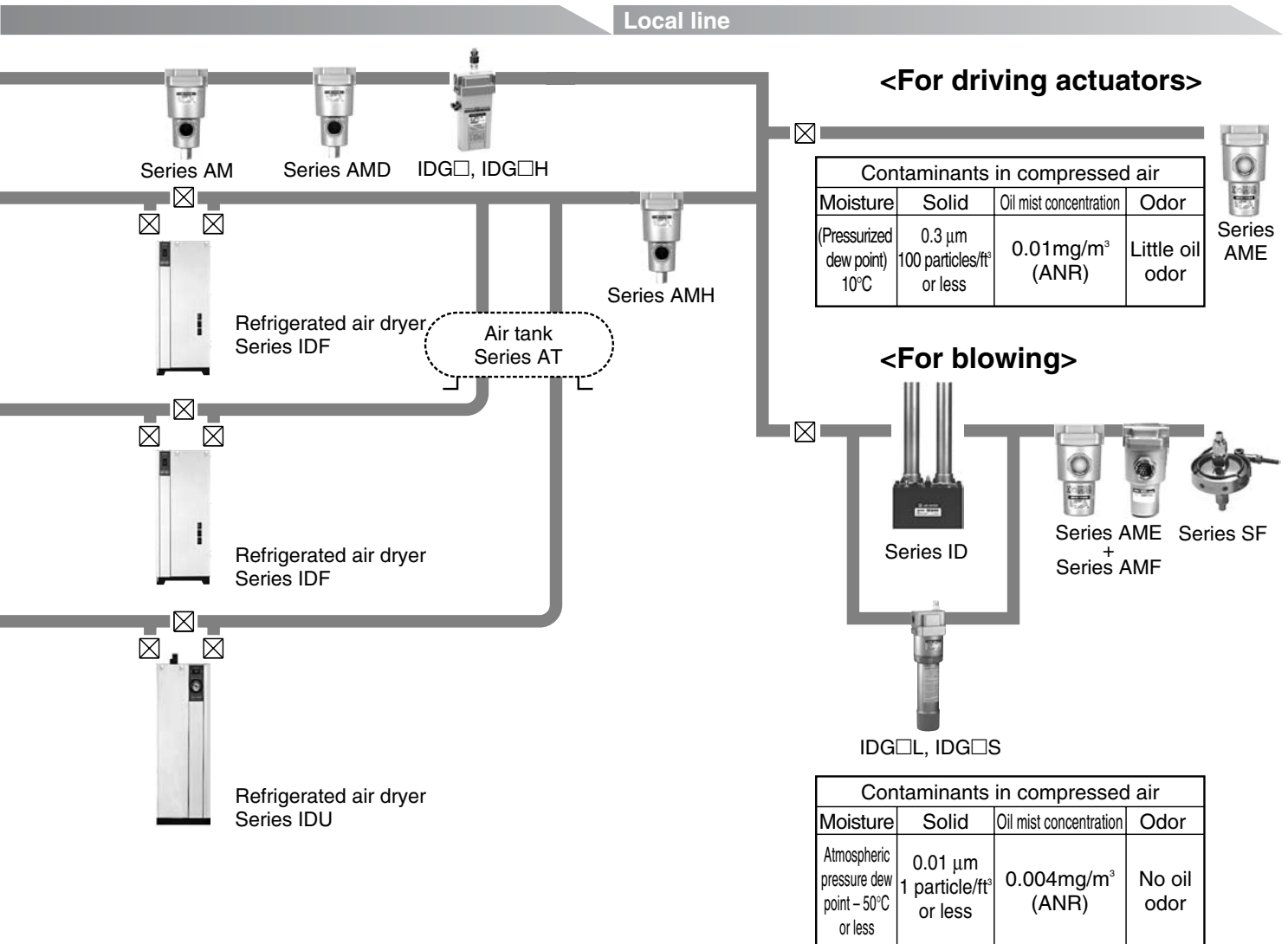

There are cases in which compressed air cannot flow due to the freezing of the refrigerated air dryer or a malfunction (heatless dryer) in the switching valve.

⚠ Caution

3. Design a layout in which the leakage of the coolant water and the dripping of condensation are taken into consideration.

A water-cooled aftercooler that uses coolant water could lead to water leakage due to freezing. Depending on the operating conditions, the refrigerated air dryer and its downstream pipes could create a dripping of water droplets due to condensation formed by supercooling.

4. Provide a design that prevents back pressure and backflow.

The generation of back pressure and backflow could lead to

equipment damage.

Take appropriate safety measures, including the proper installation methods.

5. Depending on the model and operating conditions, the life span of air cylinders may be shortened when they are used in an environment of super dry air (atmospheric pressure dew point: -50°C) or high-purity nitrogen gas or when such super dry air or high-purity nitrogen gas is used as the fluid.

Please contact with SMC for further details on applicable series, models, operating conditions and life spans.

6. Blowing system

Even a small amount of dust can be a problem for blowing systems.

Install Clean Gas Filter Series SF to the end of the blowing line.



Clean series: Common Precautions 2

Be sure to read before handling.

Refer to the main text for detailed precautions on every series.

Piping: Inside of Clean Room

⚠ Caution

1. Do not make the piping for the air cylinder relief port and regulator breathing vent piping common with solenoid valve exhaust piping.

This can cause malfunctions in the air cylinder or regulator pressure change.

2. Arrange the piping so that the exhaust air of the solenoid valves is exhausted outside of the clean room.

3. Air filter drain piping

Exhaust drainage outside the clean room through piping from the drain guide of the air filter.

4. Arrange the membrane dryer air purge piping using a standard size tubing so that air is exhausted outside the clean room.

5. Take precautions so that the threaded portion of the piping connection or the tubing connection will not be loosened.

Take sufficient precautions against the piping shaking along with the vibration of the equipment.

6. Use polyurethane tubing containing no plasticizer.

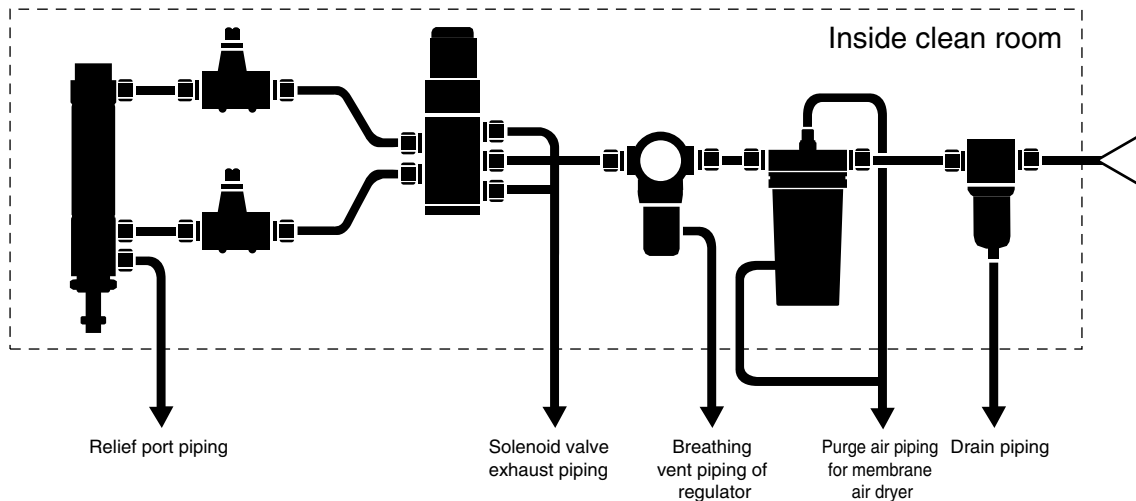

Handling

⚠ Caution

1. The inner bag of a double-packed clean series package should be opened in a clean room or clean environment.
2. When standard pneumatic equipment is brought into a clean room, spray high-purity air upon it and remove dust thoroughly by wiping the external surfaces of the cylinder tube, solenoid valves and air line equipment with alcohol.
3. To replace parts or disassemble the product in a clean room, first exhaust the compressed air inside the piping to the outside of the clean room before the work.
4. Do not use rotation type mounting brackets such as clevises, trunnions, etc.. They will generate a considerable amount of particulate matter due to the sliding friction between the metal parts.

Lubrication / In the Case of Actuator

⚠ Warning

Be sure to wash your hands after handling fluoro-resin grease. The grease itself is not hazardous but it can produce a hazardous gas at temperatures exceeding 260°C.

⚠ Caution

1. Do not use any greases but those specified by SMC. Use of greases not specified will cause malfunctions or particle generation.
2. Do not lubricate the products since they are of a nonlubricant type. As the clean series actuators are lubricated at the factory with fluoro-resin grease, the product specifications may not be satisfied if turbine oil or other such lubricants are applied.

Piston speed

⚠ Caution

The cylinder speed upper limit that retains the particle generation grade is 400 mm/s.



Clean series: Common Precautions 3

Be sure to read before handling.

Refer to the main text for detailed precautions for every series.

Suction flow rate of vacuum suction types

⚠ Caution

For the vacuum suction types (Series 11-/13-/22-), perform vacuum suction at the vacuum port to retain the particle generation grade.

The optimum suction flow rate varies depending on series and sizes. Refer to "Suction flow rate of vacuum suction type (Reference values)" for each series. (The vacuum pressure will be approximately -27 kPa at around 1 m from the vacuum suction port.) Please consult SMC for further details.

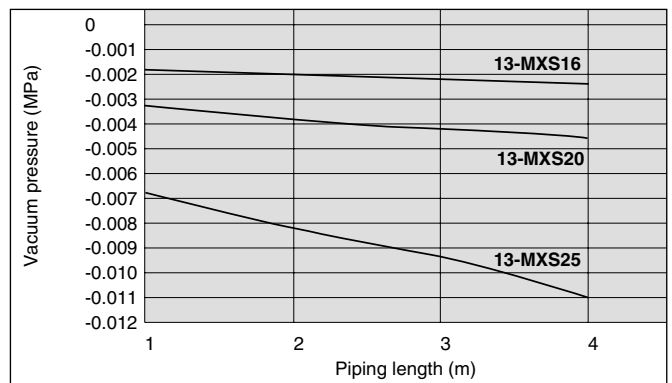
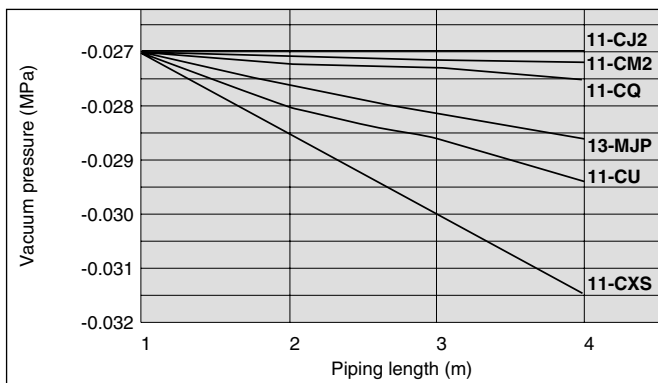
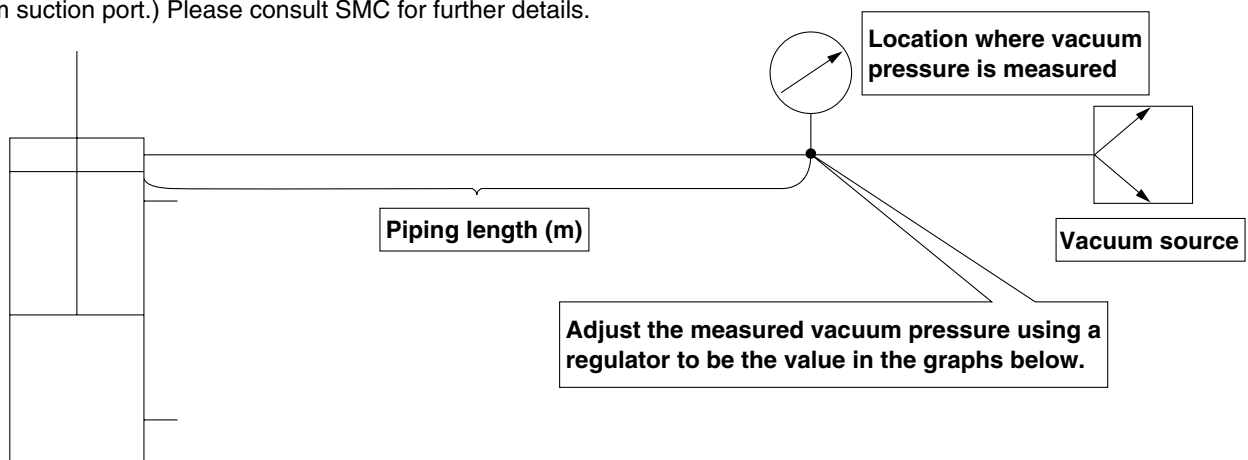



SMC Corporation

Akihabara UDX 15F,
4-14-1, Sotokanda, Chiyoda-ku, Tokyo 101-0021, JAPAN
Phone: 03-5207-8249 FAX: 03-5298-5362
URL <http://www.smcworld.com>
© 2008 SMC Corporation All Rights Reserved

Specifications are subject to change without prior notice
and any obligation on the part of the manufacturer.

D-SZ 1st printing MT printing MT 16400SZ Printed in Japan.