

# Pocket Leak Detector

New



LED indicators

## Catch the leaks, in the palm of your hand!

**Compact/lightweight: Body 125 g (including batteries)**

One-handed operation helps prevent fatigue

**Notifications with LED indicators and vibration**

Vibration makes notifications more clear even in noisy environments

**Simple operation**

Just hold it up and check for air leaks more easily

Contributes  
to CO<sub>2</sub>  
reduction!

## Air leak locations in factories/facilities

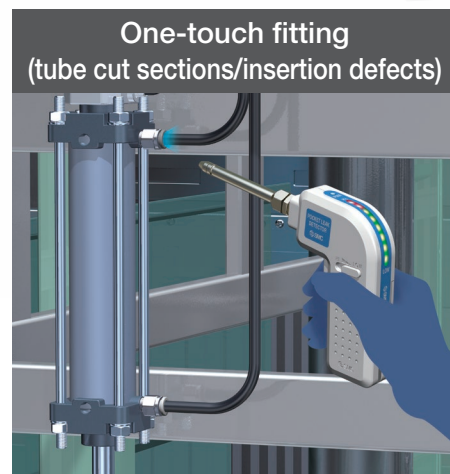

**PLD Series**



CAT.ES100-182A

# Simple! Just hold it up and check for air leaks more easily

## Conventional air leak confirmation methods

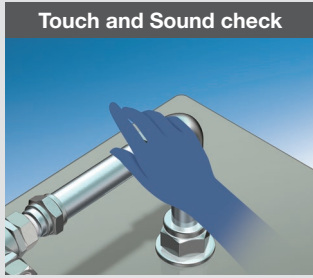

Touch and Sound check

**Problems**

- Hard to hear in noisy environments
- Individual differences occur



Soapy water bubbles

**Problems**

- Time-consuming preparation and work
- Can't be applied in some locations
- Effects on equipment/wiring



Commercial air leak detectors

**Problems**

- Heavy/large/complex operation
- Notification sound is hard to hear
- Wearing headphones onsite

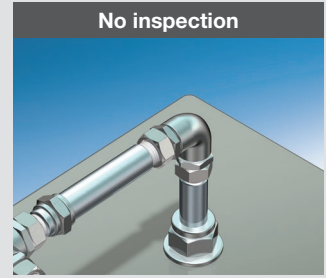

No inspection

**Problems**

- Lost opportunities to save air
- Countermeasures for device problems not taken

Problems with work hours, usability, safety, etc. We need to detect it more easily and conveniently!

With the Pocket Leak Detector...

Maintenance hours/  
costs reduced

Equipment quality/  
productivity improved

Maintainability  
improved

Power costs/CO<sub>2</sub>  
emissions reduced

Air leaks can be confirmed anywhere, on the spot, easily

**Work time is reduced**

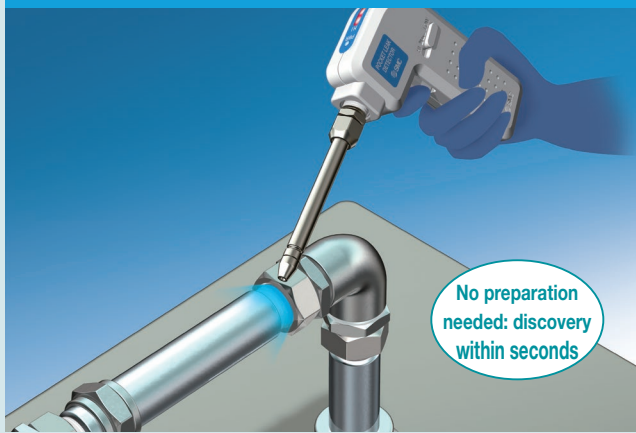

No preparation  
needed: discovery  
within seconds

**Usable as a tool for everyday air-saving/  
improvement measures**



Easily portable,  
requiring no setup

**Reduction of labor costs and production opportunity losses / Improvement of  
equipment quality and productivity (preventive maintenance)**

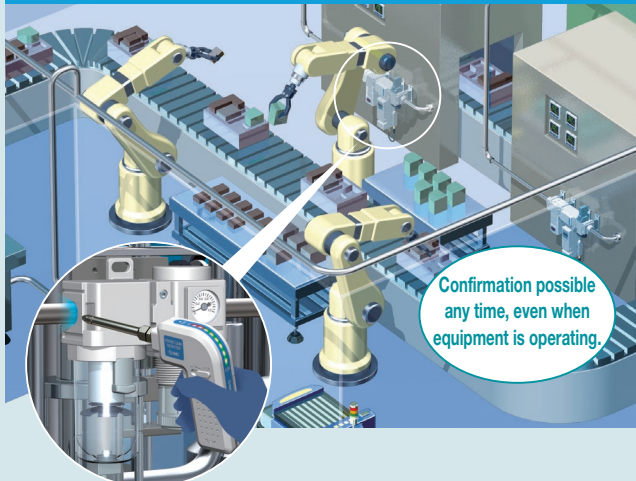

Confirmation possible  
any time, even when  
equipment is operating.

**Workload reduced**

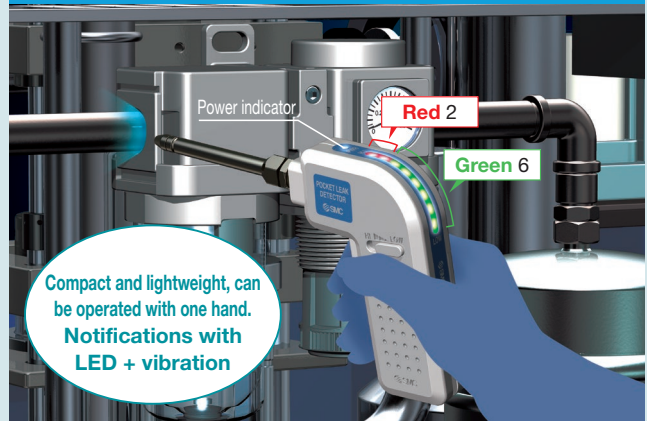

Compact and lightweight, can  
be operated with one hand.  
Notifications with  
LED + vibration

# Compact and lightweight, operated with one hand to reduce fatigue

**Easy operation**

Simply pull the trigger and move the detection nozzle along the pipe!



**Lightweight**

Approx. 125 g (body: 75 g, batteries: approx. 50 g)  
 +42 g when short nozzle is attached  
 +80 g when long nozzle is attached

**Power indicator + low battery voltage indicator**

Power indicator (blue)



In use: LED ON

Notifies user when batteries need replacing



Low batteries: Flashing

**Height** 121.2 mm

**Notifications with LED indicator (8-LED level meter) + Vibration**

Notifications with LED + vibration when an air leak is detected.  
 \* Vibration only at maximum level (all LED's ON).

How to use: **p. 4**

**Trigger (power switch)**

Pull the trigger to turn the power ON.

How to use: **p. 4**

**Sensitivity selector switch (Hi/Mid/Lo)**

3 levels selectable

How to use: **p. 4**

**Battery-powered (AA x 2)**

\* Batteries are not included with the product.

**Depth** 76.6 mm

**Width** 24 mm

**Protective cover (included)**

Absorbs impact when dropped, preventing damage or malfunction of the product. Be sure to attach the cover when using the long nozzle.

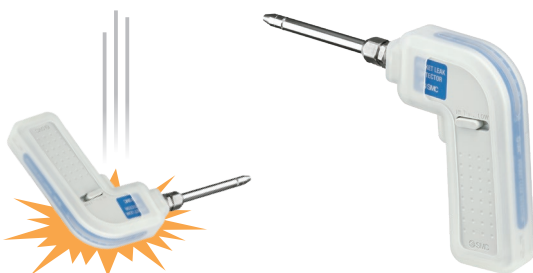

No worries about accidental dropping!

**With handstrap (included)**

Peace of mind with a drop-prevention strap included.



..... Detection principles .....

Detects air leaks even in noisy factory environments!

■ **Microphone Catches Ultrasonic Waves**

When compressed air leaks from a pipe, it generates a fairly strong ultrasonic wave around 40 kHz. The microphone picks up this sound and detects the air leak.

■ **Unique Signal Processing eliminates noise other than the air leak.**

Proprietary processing circuits and signal processing techniques are used to extract only the air leak location frequency, a detection method that is less likely to be affected by other frequencies such as ambient noise.

⇒ **Stable detection method less likely to be affected by other frequencies!**

■ **Leakage Rate: Several tens of cc/min or more**

As a guideline, use this product for small to medium air leaks (approximately 100 to 300cc/min) which are difficult to detect manually or by ear. It may be difficult to detect and identify the leak location if the operating pressure is 0.1 MPa or less, the leakage amount is a small leak of a few cc, or a large leak of 500 cc/min or more (which can be heard by ear or touch), or in a narrow space or where there is an obstruction.



..... Nozzle variations .....

**Nozzle used to pinpoint leak locations**

Two detection nozzle types are available. (Main body connection: Rc1/4 female thread)  
Ultrasonic waves caused by air leaks are more easily captured and the influence of surrounding noise is reduced.

● **Short nozzle (100 mm) p. 7**

Ideal for detection in narrow spaces at close range.

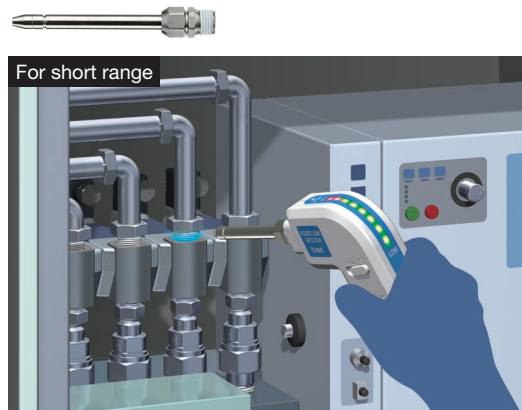

● **Long nozzle (300 mm) p. 7**

Ideal for detection in locations where the short type can't reach.



**Reference** Use of a nozzle prepared by the customer is also possible in accordance with the detection location.

● **Example: One-touch fitting + tube**

Can be used as a simple nozzle  
\* Material, length and diameter may affect detection sensitivity.

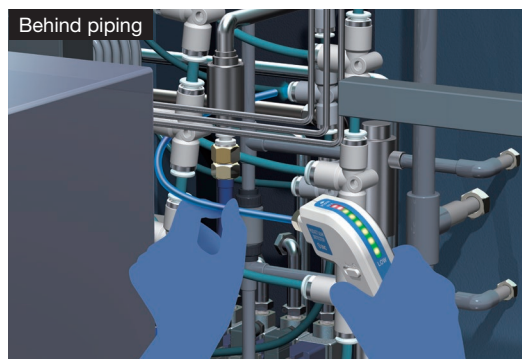

## How to use

While holding down the power switch (trigger), move the unit along the area where air leaks are to be detected. Notifies the user with the LED indicators ON (Green/Red) + vibration (all LED's ON) when an air leak is detected.

## LED indicator patterns

The LED indicator visually indicates the presence and degree of air leakage.



The LED indicators turn ON in accordance with the strength (sound pressure) of the detected ultrasonic waves. As the detection level increases, the LED's shift from Green to Red; when the meter is at it's maximum (all LED's ON), the product vibrates for 0.3 seconds. The intensity (sound pressure) of ultrasonic waves varies according to conditions such as the detection distance, leakage amount and operating pressure.

Use the **LED indicator as a guide to intuitively identify and locate air leaks.** \* This does not indicate the amount of air leakage.

## Sensitivity setting

Sensitivity can be adjusted to suit the air leak detection level using the sensitivity selector switch (Hi/Mid/Lo).

### Sensitivity adjustment procedure

Begin use at Hi/Mid and adjust the sensitivity after detecting air leaks. Shifting gradually from Hi/Mid to Low enables identification of air leak locations.

Note: Search for air leaks with the product as close to the piping as possible, moving it gradually over the areas around potential leaks.

### Sensitivity adjustment image

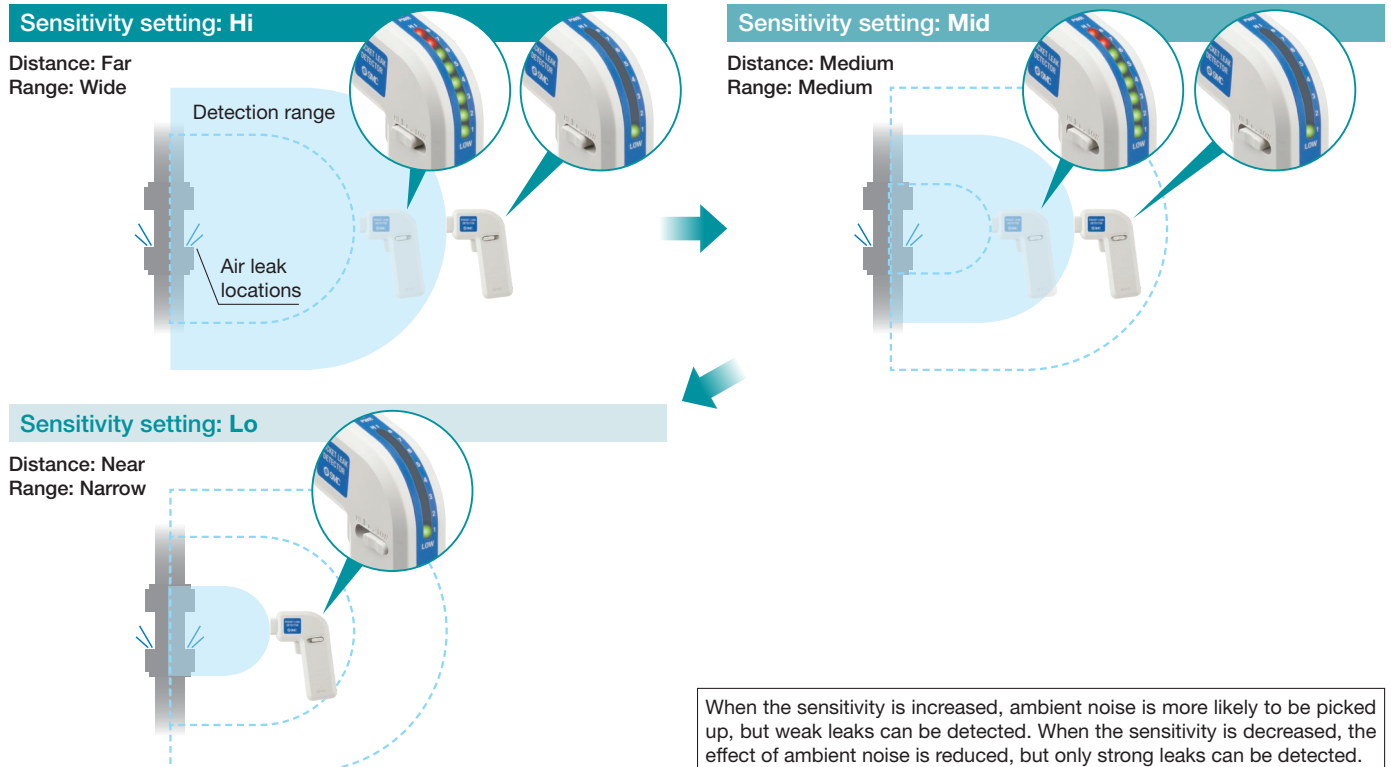

Reference: Target locations

**Fittings/tubes**

Sealing defects due to leaks at piping joints

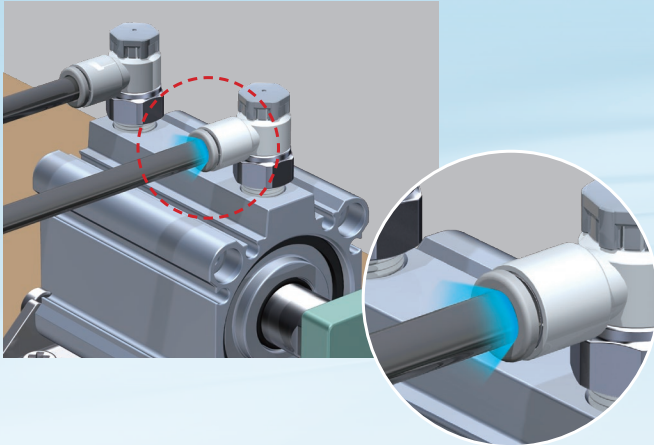

**Actuators**

Leaks due to gasket wear/deterioration

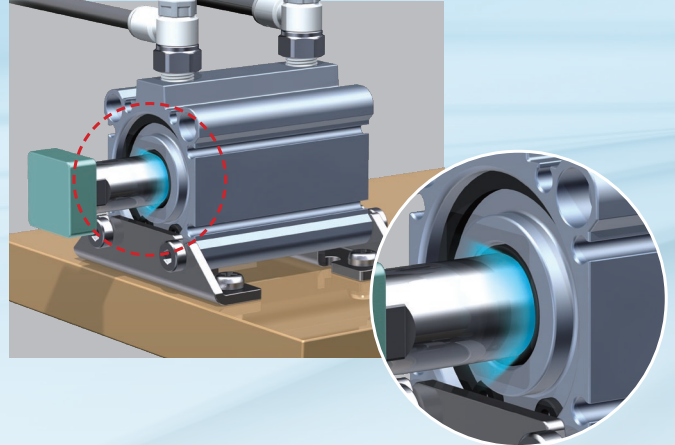

**Valves**

Leaks due to gasket wear/deterioration

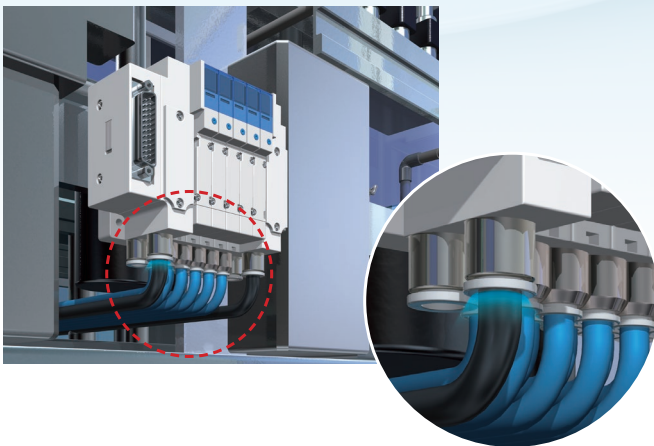

**Regulator**

Leaks in threaded parts due to poor installation

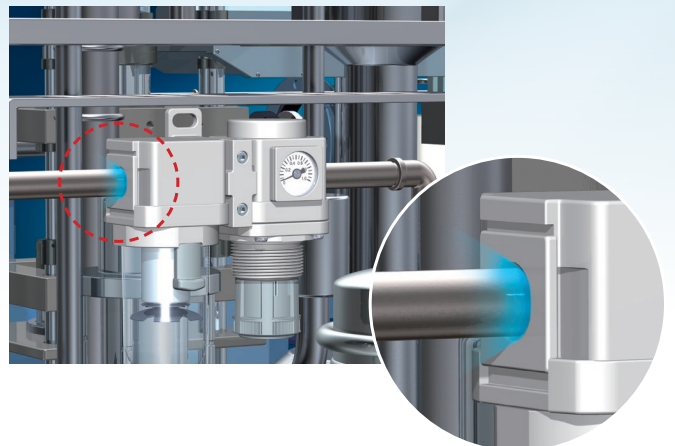

**Air tanks**

Leaks in threaded parts due to poor installation

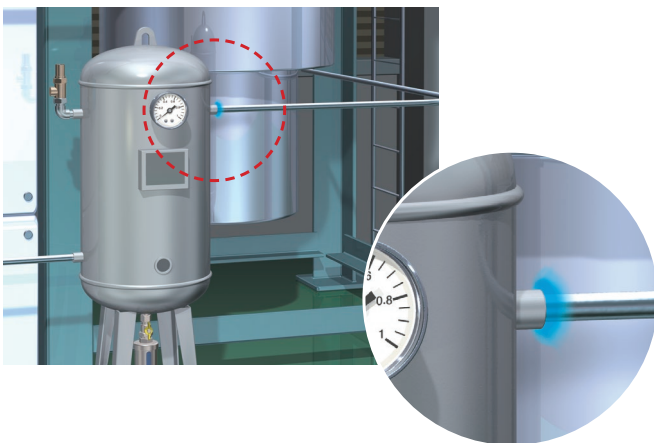

**Steel tube piping**

Leaks in threaded parts due to aging

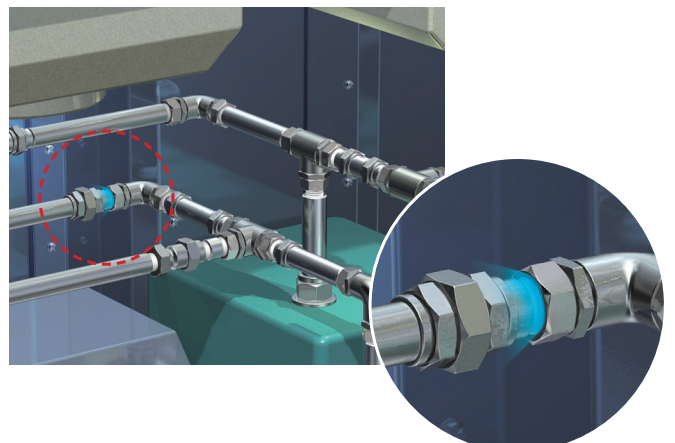

# CONTENTS

---

## Pocket Leak Detector *PLD Series*



How to Order .....	p. 7
Specifications .....	p. 7
Detection Characteristics .....	p. 8
Dimensions .....	p. 9
Precautions for Use .....	p. 10
Safety Instructions .....	Back Cover

# Pocket Leak Detector

## PLD Series

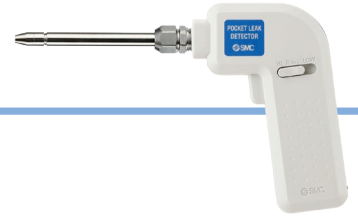

### How to Order

PLD - **100**

①

#### ① Nozzle type

Symbol	Nozzle type	Nozzle length
<b>No symbol</b>	No nozzle	
<b>100</b>	Short nozzle set*	100 mm
<b>300</b>	Long nozzle set*	300 mm

\* Part number for a set of nozzle and fitting. The nozzle and fitting are included (unassembled). Refer to "Nozzle mounting method" in the operation manual for the assembly method.

#### Individual nozzle (order separately)

Model	Length
<b>VMG1-08-350-100</b>	100 mm
<b>VMG1-08-350-300</b>	300 mm

### Specifications

<b>Power voltage</b>	3 VDC; 2 AA batteries* <sup>1</sup>
<b>Battery life guidelines</b>	75 days when operating 100 times a day* <sup>2</sup>
<b>Pipe connection size</b>	Rc1/4
<b>Operating temperature range</b>	In operation: 5 to 45°C; in storage: -10 to 60°C (no condensation or freezing)* <sup>3</sup>
<b>Operating humidity range</b>	In operation/storage: 35 to 85% RH (no condensation)
<b>Enclosure</b>	IP40
<b>Weight</b>	Approx. 125 g (body: 75 g, batteries: approx. 50 g)
<b>Standards</b>	CE/UKCA marking

\*<sup>1</sup> Prepare 2 AA batteries separately, as they are not included.

\*<sup>2</sup> When a standard alkaline battery of capacity 2000 mAh is used. Fluctuates depending on operating environment and conditions.

\*<sup>3</sup> Dry batteries are not included in storage condition.

# PLD Series

## Technical Information

### Detection Characteristics

The following simple graph shows the relationship between the detection distance from the air leak location and when the LED indicator is ON (air leak detection level). The graphs below are examples from verifications by SMC; the results may fluctuate depending on various conditions, so please use them as a reference only.

### Relationship Graphs: Detection Distance / Sensitivity / LED Indicators (Air leak detection level)

[Verification conditions] No nozzle

[Air leak conditions] Operating pressure: 0.1 MPa/0.3 MPa/0.5 MPa    Leak location orifice diameters:  $\phi 0.1/\phi 0.2/\phi 0.3$

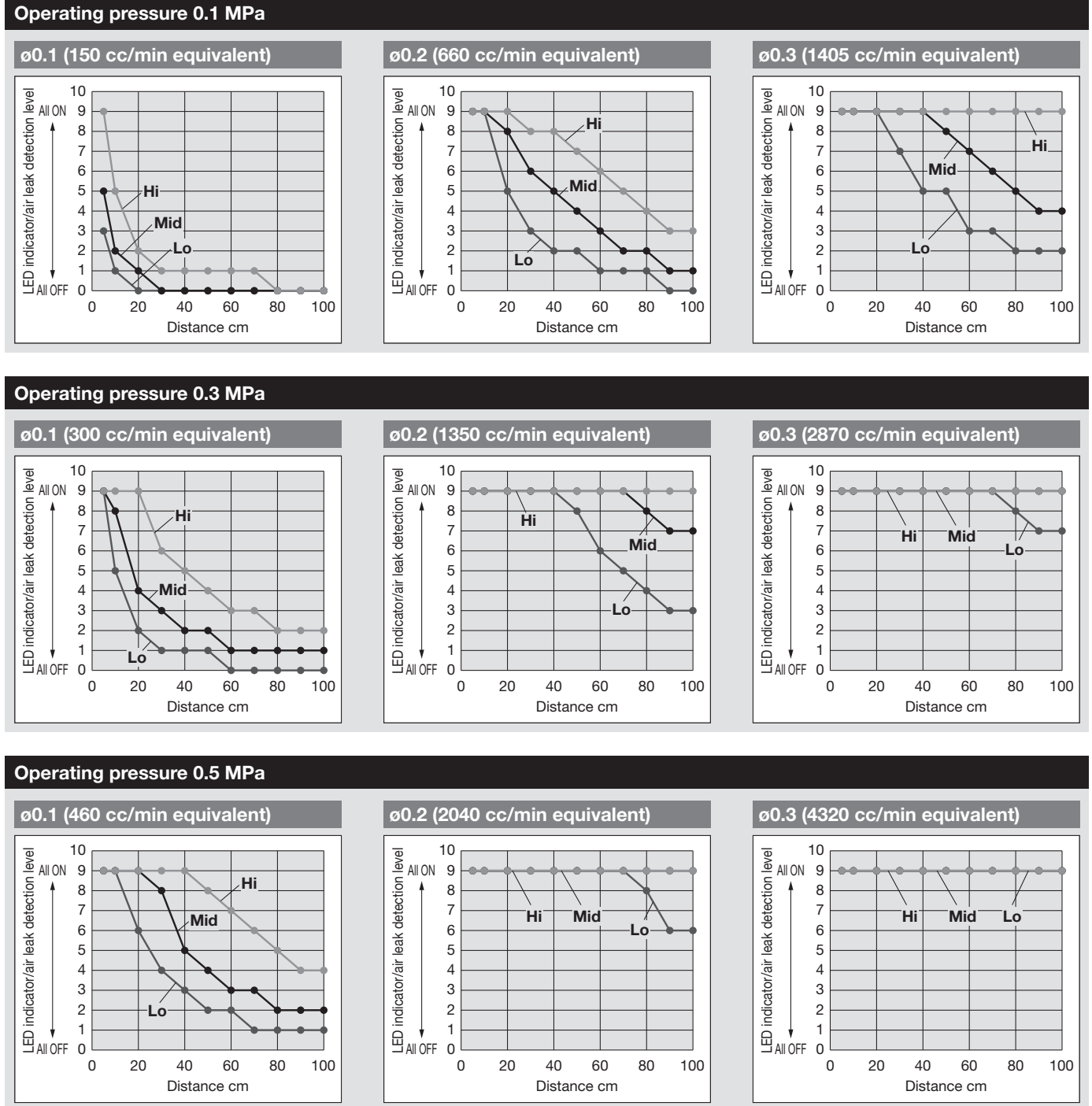

### ⚠ Caution

LED indicator turns ON to indicate the air leak detection strength (sound pressure) according to the air leak conditions (pressure, leak location dimensions/shape, etc.); and does not indicate the flow rate values.

# PLD Series

## Dimensions

### No nozzle

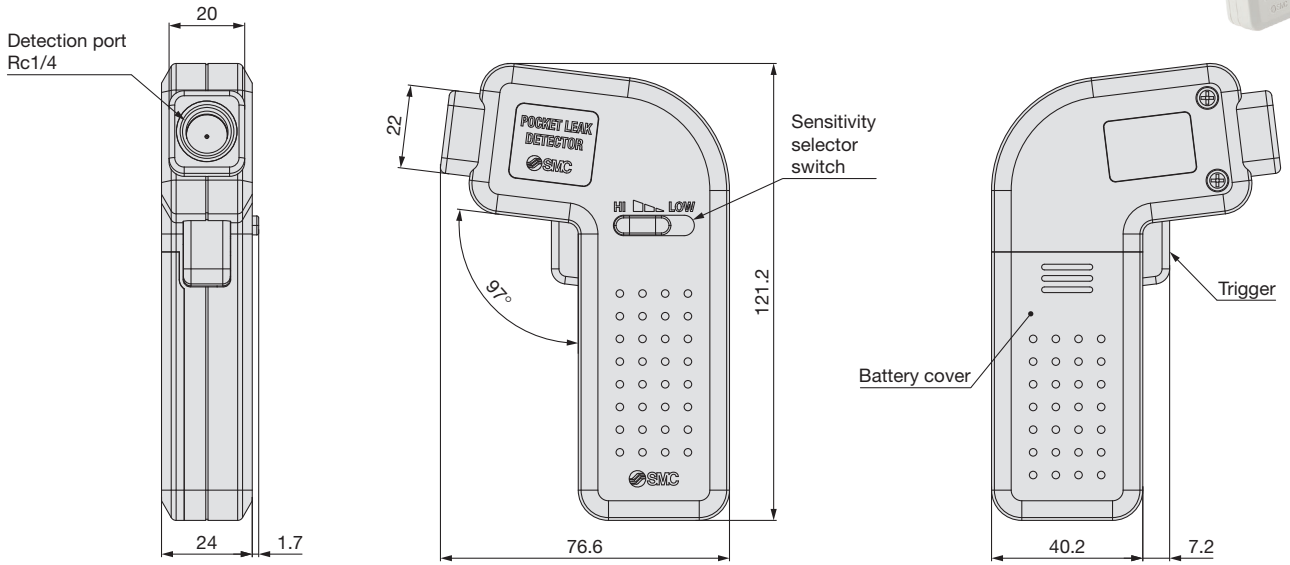

### PLD-100

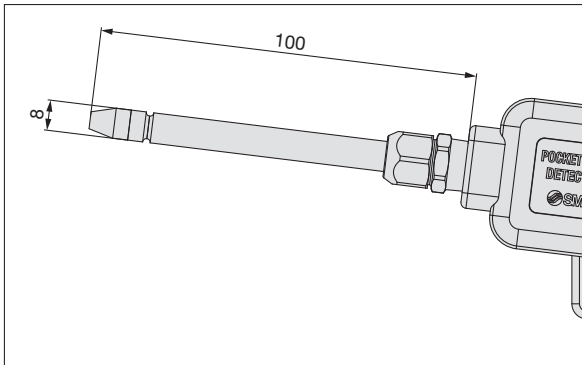

### PLD-300

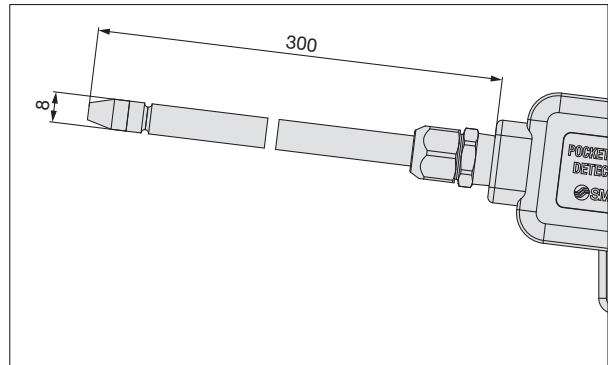

### Precautions for Use

- **Use by moving close to and along the piping**

Use as near as possible to suspected air leak locations.

- **For pinpoint detection, use with a nozzle attached**

By attaching a nozzle, it is possible to narrow down the location of the air leak.

- **As a guideline, use the product for small to medium leaks of several tens of cc/min or more**

This product is designed for small to medium leaks of several tens of cc/min or more, and may not react to minimal leaks of a few cc/min or less.

Except for very small leaks, if there is no reaction at high sensitivity, the possibility of an air leak is extremely low.

- **The easiest direction to detect is from the front, within an angle of 90°**

When using a nozzle to make it easier to pick up ultrasonic waves, detection is easier if used from the front and directed at the leak location.

If the detection is unstable, try changing the angle within a range of approximately 90°.

- **Avoid noise and air blow when in use**

The product may react in environments where other frequencies around 40 kHz are generated, such as air blowers, noise, or ultrasonic equipment.

Be careful to use as far away as possible from air blow locations and at times when noise is low.

- **Use the LED indicators as a simple leak level meter**

The LED indicators act as a simple display of detected ultrasonic wave levels; they can be used as a level meter providing a rough understanding of leak location size. Since flow rate varies depending on the diameter and pressure of the leak location, the flow rate value cannot be displayed or converted.

(refer to the "Detection characteristics graph" for an image of the relationship between detection distance and LED indicators).

- **Detectable fluids: Compressed air**

Use the product for the detection of compressed air. For fluids other than compressed air contact SMC.

Leaks of fluids other than compressed air may not be detected, as their frequency characteristics may differ.

The product cannot be used with flammable gases.

### Precautions

**This product is intended to reduce the time required to identify the presence and location of air leaks; it does not provide precise measurements of leak quantities.**

## Safety Instructions

These safety instructions are intended to prevent hazardous situations and/or equipment damage. These instructions indicate the level of potential hazard with the labels of “**Caution**,” “**Warning**” or “**Danger**.” They are all important notes for safety and must be followed in addition to International Standards (ISO/IEC)\*1), and other safety regulations.

 **Danger :** **Danger** indicates a hazard with a high level of risk which, if not avoided, will result in death or serious injury.

 **Warning:** **Warning** indicates a hazard with a medium level of risk which, if not avoided, could result in death or serious injury.

 **Caution:** **Caution** indicates a hazard with a low level of risk which, if not avoided, could result in minor or moderate injury.

\*1) ISO 4414: Pneumatic fluid power - General rules and safety requirements for systems and their components  
ISO 4413: Hydraulic fluid power - General rules and safety requirements for systems and their components  
IEC 60204-1: Safety of machinery - Electrical equipment of machines - Part 1: General requirements  
ISO 10218-1: Robots and robotic devices - Safety requirements for industrial robots - Part 1: Robots etc.

### Warning

#### 1. The compatibility of the product is the responsibility of the person who designs the equipment or decides its specifications.

Since the product specified here is used under various operating conditions, its compatibility with specific equipment must be decided by the person who designs the equipment or decides its specifications based on necessary analysis and test results. The expected performance and safety assurance of the equipment will be the responsibility of the person who has determined its compatibility with the product. This person should also continuously review all specifications of the product referring to its latest catalog information, with a view to giving due consideration to any possibility of equipment failure when configuring the equipment.

#### 2. Only personnel with appropriate training should operate machinery and equipment.

The product specified here may become unsafe if handled incorrectly. The assembly, operation and maintenance of machines or equipment including our products must be performed by an operator who is appropriately trained and experienced.

#### 3. Do not service or attempt to remove product and machinery/equipment until safety is confirmed.

1. The inspection and maintenance of machinery/equipment should only be performed after measures to prevent falling or runaway of the driven objects have been confirmed.
2. When the product is to be removed, confirm that the safety measures as mentioned above are implemented and the power from any appropriate source is cut, and read and understand the specific product precautions of all relevant products carefully.
3. Before machinery/equipment is restarted, take measures to prevent unexpected operation and malfunction.

#### 4. SMC products cannot be used beyond their specifications. They are not developed, designed, and manufactured to be used under the following conditions or environments. Use under such conditions or environments is not allowed.

1. Conditions and environments outside of the given specifications, or use outdoors or in a place exposed to direct sunlight.
2. Use for nuclear power, railways, aviation, space equipment, ships, vehicles, military application, equipment affecting human life, body, and property, combustion equipment, entertainment equipment, emergency shut-off circuits, press clutches, brake circuits, safety equipment, etc., and use for applications that do not conform to standard specifications such as catalogs and operation manuals.
3. Use for interlock circuits, except for use with double interlock such as installing a mechanical protection function in case of failure. Please periodically inspect the product to confirm that the product is operating properly.

### Caution

**SMC develops, designs, and manufactures products to be used for automatic control equipment, and provides them for peaceful use in manufacturing industries.**

**Use in non-manufacturing industries is not allowed.**

Products SMC manufactures and sells cannot be used for the purpose of transactions or certification specified in the Measurement Act of each country. The new Measurement Act prohibits use of any unit other than SI units in Japan.

### Limited warranty and Disclaimer/ Compliance Requirements

The product used is subject to the following “Limited warranty and Disclaimer” and “Compliance Requirements”.

Read and accept them before using the product.

#### Limited warranty and Disclaimer

1. The warranty period of the product is 1 year in service or 1.5 years after the product is delivered, whichever is first.\*2)  
Also, the product may have specified durability, running distance or replacement parts. Please consult your nearest sales branch.
2. For any failure or damage reported within the warranty period which is clearly our responsibility, a replacement product or necessary parts will be provided. This limited warranty applies only to our product independently, and not to any other damage incurred due to the failure of the product.
3. Prior to using SMC products, please read and understand the warranty terms and disclaimers noted in the specified catalog for the particular products.

\*2) **Suction cups (Vacuum pads) are excluded from this 1 year warranty.**

A suction cup (vacuum pad) is a consumable part, so it is warranted for a year after it is delivered.

Also, even within the warranty period, the wear of a product due to the use of the suction cup (vacuum pad) or failure due to the deterioration of rubber material are not allowed by the limited warranty.

#### Compliance Requirements

1. The use of SMC products with production equipment for the manufacture of weapons of mass destruction (WMD) or any other weapon is strictly prohibited.
2. The exports of SMC products or technology from one country to another are governed by the relevant security laws and regulations of the countries involved in the transaction. Prior to the shipment of a SMC product to another country, assure that all local rules governing that export are known and followed.

## Safety Instructions

Be sure to read the “Handling Precautions for SMC Products” (M-E03-3) and “Operation Manual” before use.