

Circulating Fluid Temperature Controller Thermo-chiller



Dual Channel Thermo-chiller for Lasers

Temperatures for **2 fluid channel systems** can be controlled individually by one chiller.

New A water-cooled refrigeration type has been added to the HRL100/200 series.

	Oscillator CH1	Optical system CH2
Cooling capacity [kW]	9, 19, 26	1 (Max. 5)
Temperature stability [°C]	±0.1	±0.5
Set temperature range [°C]	5 to 35	10 to 40*1

*1 CH2 ≥ CH1

Space saving, Reduced wiring

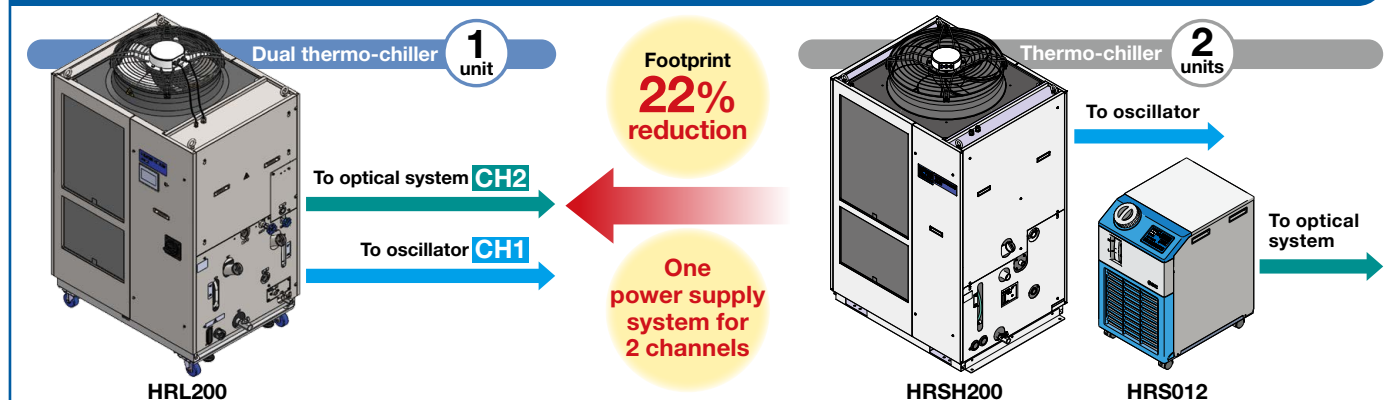

Energy saving

Power consumption reduced by **30%**

1 compressor, 1 fan and 2 pumps are controlled by inverter.

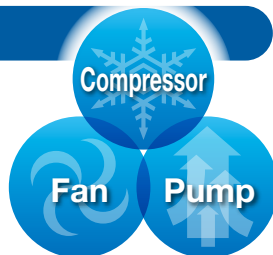

Touch panel pp. 5, 28

- Numeric keypad inputs
- Notice for alarms and maintenance
- Temperature waveform can be displayed.

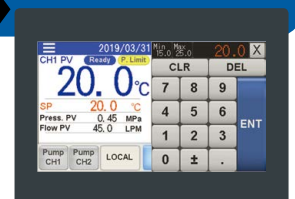

Numeric keypad display

HRL Series



CAT.ES40-68B

Space saving

Keeping the size similar to the (HRSH series) single chiller, the temperature of 2 fluid channel systems are controlled individually.



	[mm]		
	Height	Width	Depth
HRL100	1538	954	715
HRL200			
HRL300	1839	1079	850

Reduced wiring/labor

One power supply system for temperature control of 2 channels
 Less work-hour for wiring



Energy saving

Inverter control

The inverter respectively controls the number of motor rotations of the compressor, fan and pump depending on the load from the user's equipment.

Power consumption reduced by 30%*1 compared with a thermo-chiller without the inverter

With the inverter, it is possible to operate with the same performance even with the power supply of 50 Hz.

*1 For HRL300-A-20

Conditions

- Outdoor air temperature: 32°C
- Circulating fluid temperature setting: 20°C/25°C (CH1/CH2)
- Heat load in the user's equipment: 26 kW/1 kW (CH1/CH2)
- Power supply: 200 V, 60 Hz
- Circulating fluid flow rate: 125 LPM/10 LPM (CH1/CH2) to the user's equipment
- External piping: The shortest distance assumed to the user's equipment
- Values shown in the graph for a thermo-chiller without inverter are found by calculation based on an assumption that a thermo-chiller is operated with a general refrigerant circuit that controls the compressor by turning the power ON/OFF, and with a bypass to the circulating fluid circuit.

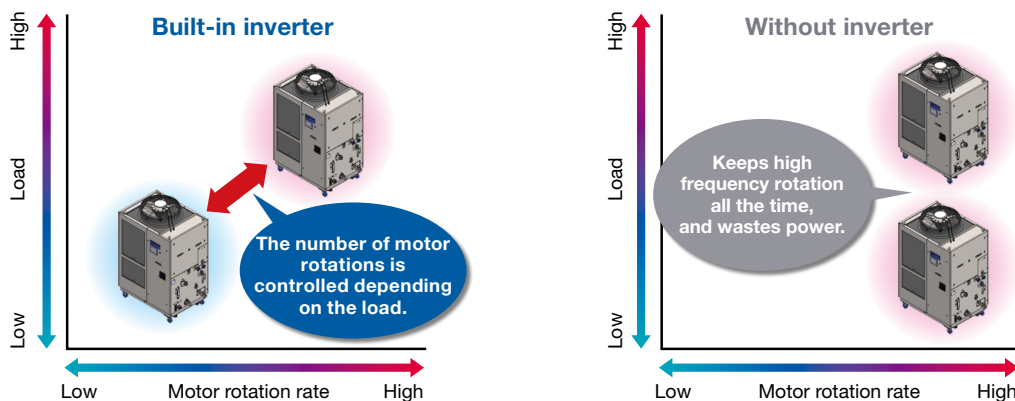

Circulating fluid can be heated without a heater.

(Circulates the hot discharged gas through expansion valve B)

Heaterless heating function

Hot discharge gas is recycled for heating.
 Energy saving by heaterless heating function

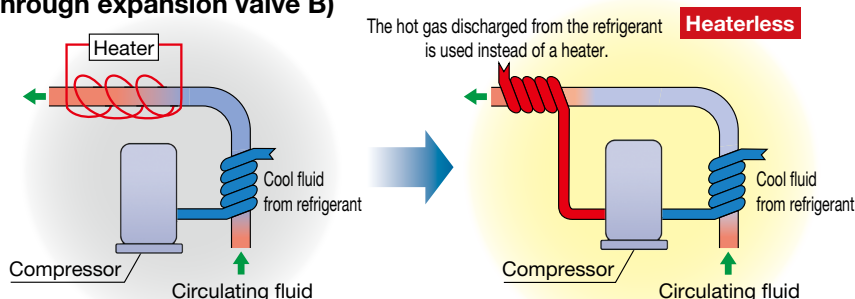

* This is just an example diagram. Existing model

HRL

One compressor controls 2 channels.

For HRL□-W-□

For HRL□-A-□

Temperature of **CH1: Oscillator** and **CH2: Optical system** is controlled individually.

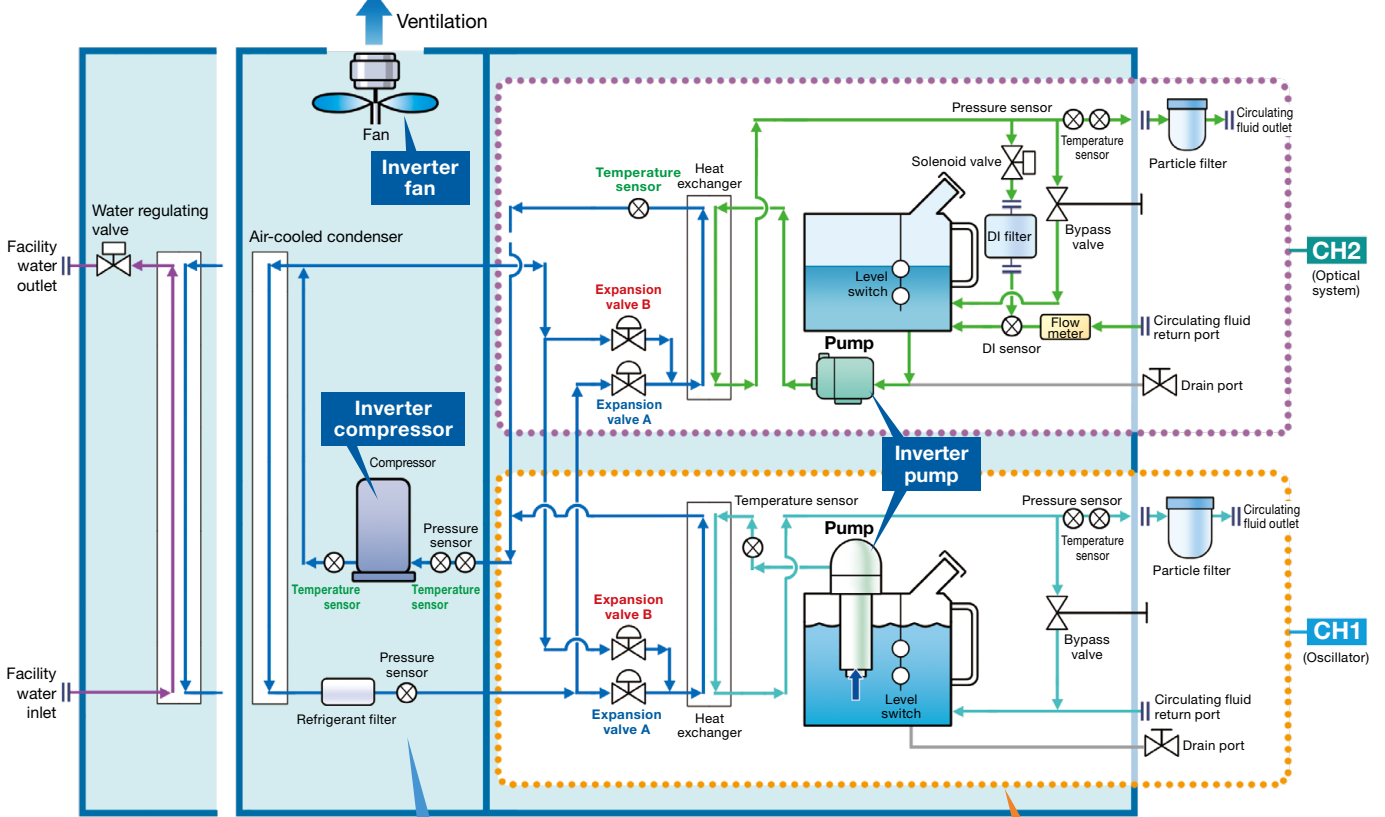

Refrigeration circuit

- The inverter compressor compresses the refrigerant gas and discharges high-temperature, high-pressure refrigerant gas.
- In the case of air-cooled refrigeration, the high-temperature, high-pressure refrigerant gas is cooled down by inverter fan ventilation in the air-cooled condenser, where it is then liquefied. In the case of water-cooled refrigeration, the refrigerant gas is cooled by a water-cooled condenser with the facility water in the facility water circuit, and becomes a liquid.
- The liquefied high-pressure refrigerant gas expands and its temperature lowers when it passes through expansion valve A, where it vaporizes after receiving heat from the circulating fluid in the evaporator.
- The vaporized refrigerant gas is sucked into the inverter compressor and compressed again.
- When heating the circulating fluid, the high-pressure, high-temperature refrigerant gas is bypassed into the evaporator by expansion valve B to heat the circulating fluid.

POINT The combination of inverter control of the compressor and fan, and the precise control of expansion valves A and B realizes energy saving operation without waste and high temperature stability.

POINT One compressor controls 2 channels which realize the independent temperature control of 2 systems.

Circulating fluid circuit

- After the circulating fluid discharged from the inverter pump is heated or cooled by the user's equipment, it returns to the tank.
- The circulating fluid is sent to the evaporator by the inverter pump, and is controlled to a set temperature by the refrigeration circuit, to be discharged to the user's equipment side again by the thermo-chiller.

POINT Adjusting the discharge pressure by pump inverter control eliminates wasteful discharge of the circulating fluid and realizes energy saving operation.

POINT Since the refrigeration circuit is controlled by the signals from 2 temperature sensors (for return and discharge), precise temperature control of the circulating fluid can be achieved. Therefore, there is no need for a tank with a large capacity to absorb the circulating fluid temperature difference, as high temperature stability can be achieved even with a small-size tank. This also contributes to space saving.

Temperature stability: $\pm 0.1^\circ\text{C}$ (CH1) When a load is stable

By controlling the inverter compressor, inverter fan, and electronic expansion valve simultaneously, it maintains the good temperature stability when the heat load fluctuates.

* For HRL300-A-20

- Conditions**
- Outdoor air temperature: 32°C
 - Circulating fluid temperature setting: $20^\circ\text{C}/25^\circ\text{C}$ (CH1/CH2)
 - Heat load in the user's equipment: 26 kW/1 kW (CH1/CH2)
 - Power supply: 200 V 60 Hz
 - Circulating fluid flow rate: 125 LPM/10 LPM (CH1/CH2)
 - External piping: Bypass piping + Heat load

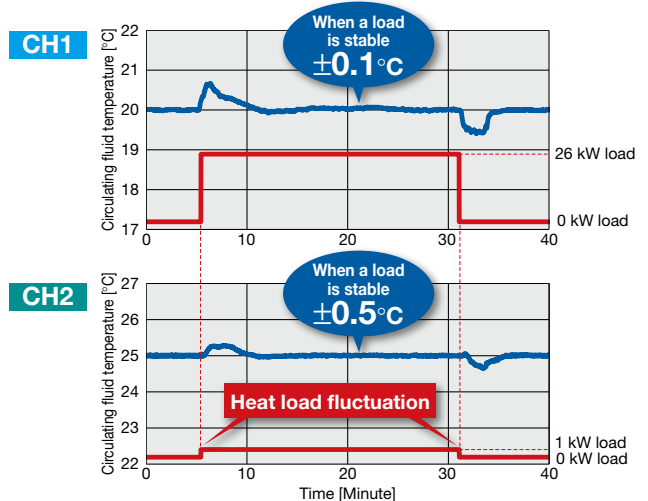

3 operation modes of the circulating fluid pump

The pump operation mode can be selected by the touch panel.

- ① Pressure control mode
 - ② Flow control mode
 - ③ Pump operating frequency (rotation) control mode
- Upper limit of the pressure can be set.

Operation screen
 Set values can be entered from the touch panel.

CH1 Pump Setting		
Press. SP	0.45	MPa
Flow SP	45.0	LPM
Output SP	50.0	%
Control Mode	PRESS FLOW %	
Press. Limit	OFF ON	0.45 MPa

<Example of the pressure control mode>

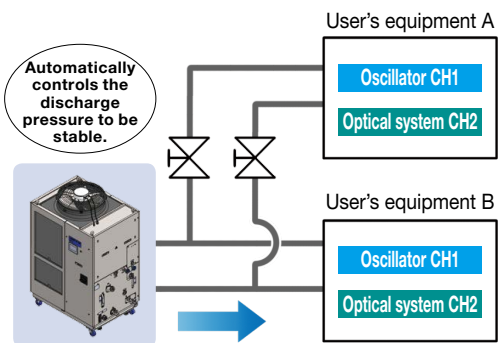

When the product is used with the flow path switched for maintenance, the pressure adjusting function controls the discharge pressure to be stable. (Secure the specified minimum flow for each branch circuit.)

Reduced maintenance hours for the pump

Both channels use the mechanical sealless type pump.

As the pump has no external leakage of the circulating fluid, a periodic check of the pump leakage and replacement of the mechanical seal are not necessary.

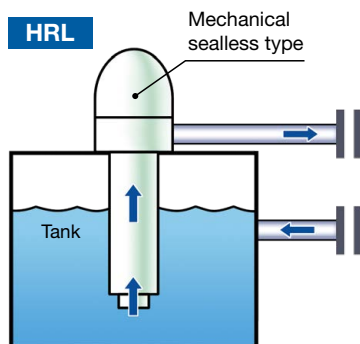

CH1: Vertical pump

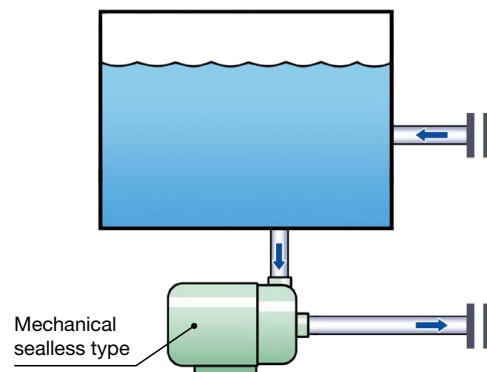

CH2: Horizontal pump

Variations

Model	Cooling method	Cooling capacity		Power supply
		CH1	CH2	
HRL100	Air-cooled refrigeration	9 kW	1 kW (Max. 5 kW)	3-phase 200 VAC (50 Hz)
HRL200	Water-cooled refrigeration	19 kW		3-phase 200 to 230 VAC (60 Hz)
HRL300	Air-cooled refrigeration	26 kW		3-phase 380 to 415 VAC (50/60 Hz)
HRL400		37 kW		3-phase 460 to 480 VAC (60 Hz)
				3-phase 380 to 415 VAC (50/60 Hz)
				3-phase 460 to 480 VAC (60 Hz)

Options in demand are standardized.

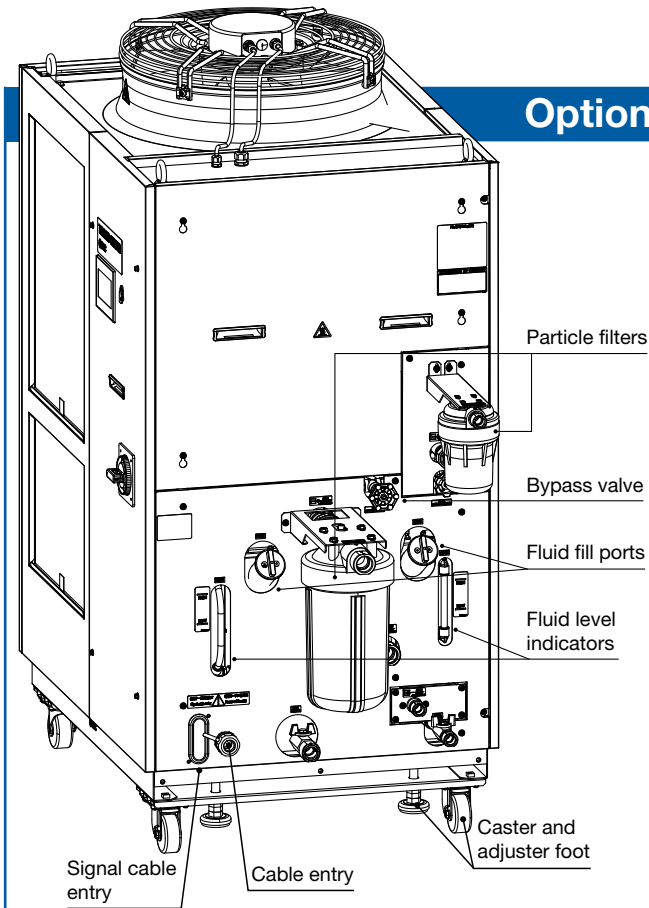

Built-in bypass circuit (CH1: Oscillator and CH2: Optical system) (Standard)

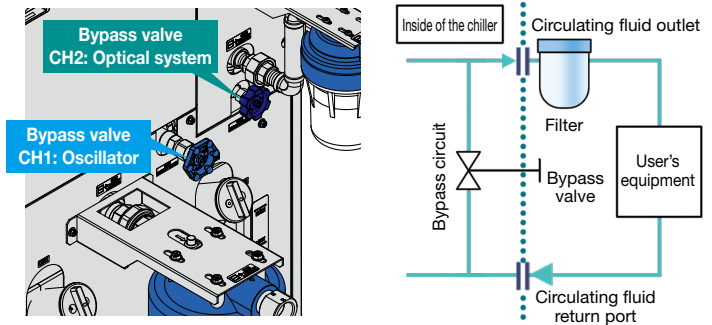

With electric conductivity control (CH2: Optical system)

DI filter + Built-in solenoid valve for control (Standard)

The electric conductivity of the circulating fluid can be set with the touch panel arbitrarily.

Set control range: 0.5 to 45.0 $\mu\text{S/cm}$

CH2 DI Setting	
Electric Conductivity SP	25.0 $\mu\text{S/cm}$
Hysteresis	0.5 $\mu\text{S/cm}$
Control	AUTO OPEN CLOSE
High Electric Conductivity Alarm	OFF WRN 45.0 $\mu\text{S/cm}$
DI Valve Status	CLOSE

Set the electrical conductivity to be set by the touch panel.

Particle filter set (Standard)

Removes foreign matter in the circulating fluid

Effective in preventing foreign matter from entering the user's equipment

Transparent bowl

Easy to visually confirm a dirty element

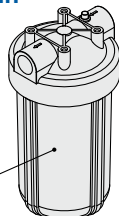

With casters and adjuster feet (Standard)

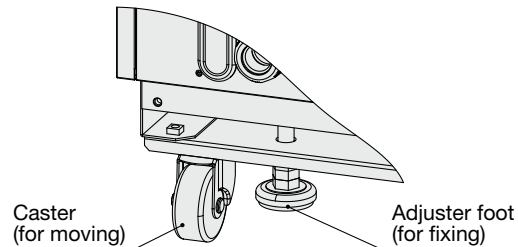

Communication functions p. 29

Serial communication (RS232C/RS485), Ethernet Modbus/TCP communication (RJ45), contact I/Os (3 inputs and 6 outputs), and analog output (2 outputs) are equipped as standard. This allows for communication with the user's equipment and system construction, depending on the application. A 24 VDC output can be also provided and is available for use with flow switches (SMC's PF3W, etc.).

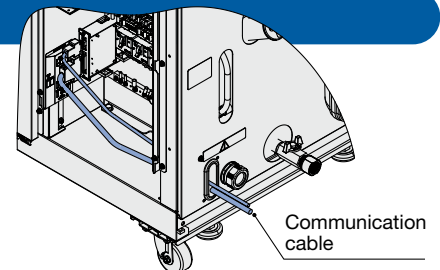

Ex. 1 Remote signal I/O through serial communication or Ethernet Modbus/TCP communication

Remote operation is enabled (to start and stop operation) through serial communication.

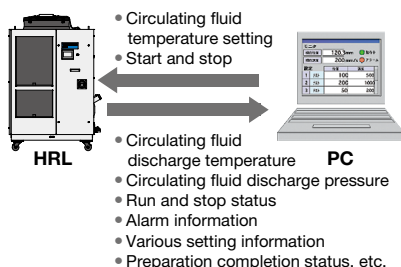

Ex. 2 Remote operation signal input

One of the contact inputs is used for remote operation and the other is used to monitor the flow of a flow switch. This is where their alarm outputs are taken in.

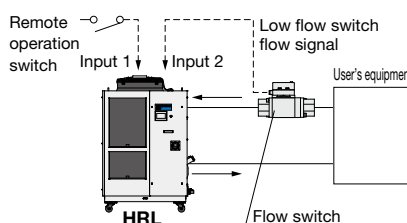

Power for flow switches (24 VDC) can be supplied by the thermo-chiller.

Ex. 3 Alarm and operation status (start, stop, etc.) signal output

The alarm and status generated in the product can be output.

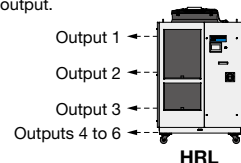

Output examples

- Output 1 : Operation status (start, stop, etc.)
- Output 2 : Outputted when alarm "FLT (operation stopped)" is generated
- Output 3 : Outputted when alarm "WRN (operation continues)" is generated
- Outputs 4 to 6 : Assigned for specified type of signals

Touch panel p. 28

Improved usability and visibility

Home screen
 2019/02/05 17:41:30
 CH1 PV Ready P. Limit 20.0 °C
 CH2 PV Ready P. Limit 30.0 °C
 SP 20.0 °C
 Press. PV 0.50 MPa
 Flow PV 40.0 LPM
 Pump CH1 Pump CH2 RUN Run / Stop

Menu screen
 2019/03/31 12:00:00
 Home Status Info. Run Time About
 CH1 Setting CH2 Setting Func. Setting Comm. Setting Graph
 Pump Pump LOCAL STOP Run / Stop

Information screen
 2019/02/05 17:44:12
 Refrigerant High Press. 2.40 MPa
 Low Press. 0.85 MPa
 Compressor 60.0 %
 Ambient Temp. 35.0 °C
 CH1 Press. 0.50 MPa PV 20.0 °C Flow 50.0 LPM
 CH2 Press. 0.50 MPa PV 30.0 °C Flow 5.0 LPM
 DI 3.0 μS/cm

Navigation callouts:
 - To status screen (from Home screen menu icon)
 - To information screen (from Menu screen Info.)
 - To check operation time screen (from Menu screen Run Time)
 - To software version screen (from Menu screen About)
 - To temperature waveform display screen (from Menu screen Graph)
 - To home screen (from Menu screen Home)
 - To CH1 setting screen (from Menu screen CH1 Setting)
 - To CH2 setting screen (from Menu screen CH2 Setting)
 - To function setting screen (from Menu screen Func. Setting)
 - To communication setting screen (from Menu screen Comm. Setting)

Numeric keypad display

Numeric data input

2019/03/31 Min 15.0 Max 25.0 20.0 X
 CH1 PV Ready P. Limit 20.0 °C
 SP 20.0 °C
 Press. PV 0.45 MPa
 Flow PV 45.0 LPM
 CLR DEL
 7 8 9
 4 5 6
 1 2 3
 0 ± . ENT
 Pump CH1 Pump CH2 LOCAL

Temperature waveform display screen

Circulating fluid temperature waveform is displayed.

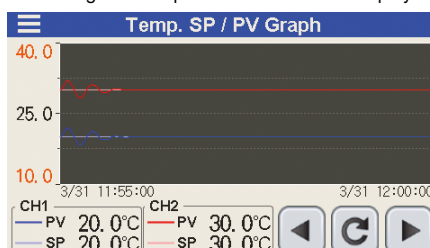

Status screen

Provides details of the temperatures, flow rates, pressures and status in the chiller

2019/02/05 17:44:12
 Refrigerant High Press. 2.40 MPa
 Low Press. 0.85 MPa
 Compressor 60.0 %
 Ambient Temp. 35.0 °C
 CH1 Press. 0.50 MPa PV 20.0 °C Flow 50.0 LPM
 CH2 Press. 0.50 MPa PV 30.0 °C Flow 5.0 LPM
 DI 3.0 μS/cm

Status indicators:
 - Sufficient (Blue)
 - Low (Yellow)
 - Insufficient (Red)

When any alarm is generated, the screen automatically moves to the information screen and displays alarm codes and alarm contents.

Information screen

2019/03/31 12:00:00
 Message
 AL01 CH1 Low Level FLT
 AL02 CH1 Low Level WRN
 AL03 CH2 Low Level FLT
 AL04 CH2 Low Level WRN
 MT01 CH1 Pump
 MT02 Compressor
 Alarm Reset History Display Alarm Maint. Alarm Maint.

Alarm information details

AL01 CH1 Low Level FLT
Trouble shooting
 The circulating fluid level in CH1 tank has decreased.
 • Fill CH1 tank with the circulating fluid.
 OK

Notice for maintenance is given when a part reaches its replacement period (operation time).

Information screen

Message is displayed when the replacement time (specified operation time) comes.

2019/03/31 12:00:00
 Message
 AL01 CH1 Low Level FLT
 AL02 CH1 Low Level WRN
 AL03 CH2 Low Level FLT
 AL04 CH2 Low Level WRN
 MT01 CH1 Pump
 MT02 Compressor
 Alarm Reset History Display Alarm Maint. Alarm Maint.

Notice for maintenance

Check operation time screen

		Run Time		
Pump	CH1	100 / 20000h	RESET	◀ Operating time for pump (CH1)
	CH2	100 / 20000h	RESET	◀ Operating time for pump (CH2)
Compressor		100 / 30000h	RESET	◀ Operating time for compressor
Fan		100 / 30000h	RESET	◀ Operating time of a fan
DI Filter		100 / 500h	RESET	◀ Usage time of a DI filter
Dustproof Filter		100 / 500h	RESET	◀ Usage time of a dustproof filter
Run Time		100h		◀ Operation time of a chiller

CONTENTS

HRL Series Dual Channel Thermo-chiller for Lasers



Thermo-chiller HRL Series

**3-phase 200 VAC (50 Hz)
3-phase 200 to 230 VAC (60 Hz)**

How to Order/Specifications	
Air-cooled refrigeration	p. 7
Water-cooled refrigeration	p. 8
Cooling Capacity	p. 9
Pump Capacity	p. 10
Dimensions	p. 11
Parts Description	p. 15

**3-phase 380 to 415 VAC (50/60 Hz)
3-phase 460 to 480 VAC (60 Hz)**

How to Order/Specifications	
Air-cooled refrigeration	p. 17
Water-cooled refrigeration	p. 18
Cooling Capacity	p. 19
Pump Capacity	p. 20
Dimensions	p. 21
Parts Description	p. 26

Recommended External Piping Flow	p. 27
Cable Specifications	p. 27
Operation Display Panel	p. 28
Alarm	p. 28
Communication Functions	p. 29

● Options

CH1, CH2 Electric Conductivity Control	p. 33
CH2 High-Pressure Pump Mounted	p. 33

Optional Accessories	p. 36
----------------------	-------

● Cooling Capacity Calculation

Required Cooling Capacity Calculation	p. 37
Precautions on Cooling Capacity Calculation	p. 38
Circulating Fluid Typical Physical Property Values	p. 38

Specific Product Precautions	p. 39
------------------------------	-------

Thermo-chiller Dual Channel Thermo-chiller for Lasers

3-phase 200 VAC (50 Hz)
3-phase 200 to 230 VAC (60 Hz)

HRL Series



How to Order

Air-cooled refrigeration

HRL 100 - A - 20 -

Cooling capacity

	CH1	CH2
100	9 kW	1 kW
200	19 kW	1 kW
300	26 kW	1 kW

Cooling method

A Air-cooled refrigeration

Pipe thread type

	Rc
Nil	Rc
F	G (with Rc-G conversion fitting)
N	NPT (with Rc-NPT conversion fitting)

Option

Symbol	Options
Nil	None
D1*1	CH1, CH2 Electric conductivity control

*1 CH2 has electric conductivity control as standard.

Power supply

20	3-phase 200 VAC (50 Hz) 3-phase 200 to 230 VAC (60 Hz)
-----------	---

Specifications

Model	HRL100-A□-20		HRL200-A□-20		HRL300-A□-20		
	CH1	CH2	CH1	CH2	CH1	CH2	
Cooling method	Air-cooled refrigeration						
Refrigerant	R410A (HFC)						
Refrigerant charge	kg		2.2		3.0		
Control method	PID control						
Ambient temperature	°C						
Circulating fluid*1	CH1: Tap water, Deionized water*9/CH2: Tap water, Deionized water						
Set temperature range	°C						
Cooling capacity*2	kW						
Heating capacity*3	kW						
Temperature stability*4	°C						
Pump capacity	Rated flow (Outlet)	L/min	45 (0.43 MPa)	10 (0.45 MPa)	45 (0.45 MPa)	10 (0.45 MPa)	
	Maximum flow rate	L/min	120	16	130	16	
	Maximum pump head	m	50	49	55	49	
	Settable pressure range*5	MPa	0.10 to 0.50	0.10 to 0.49	0.10 to 0.55	0.10 to 0.49	0.10 to 0.68
Minimum operating flow rate*6	L/min	20	2	25	2	40	
Tank capacity	L	42	7	42	7	60	
Bypass circuit (With valve)	Installed						
Electric conductivity setting range	μS/cm	—	0.5 to 45.0	—	0.5 to 45.0	—	
Particle filter nominal filtration rating (Accessory)	μm	5				—	0.5 to 45.0
Circulating fluid outlet, circulating fluid return port	CH1: Rc1 (Symbol F: G1, Symbol N: NPT1) CH2: Rc1/2 (Symbol F: G1/2, Symbol N: NPT1/2)						
Tank drain port	CH1: Rc3/4 (Symbol F: G3/4, Symbol N: NPT3/4) CH2: Rc1/2 (Symbol F: G1/2, Symbol N: NPT1/2)						
Fluid contact material (Metal/Resin)	CH1: Stainless steel, Copper (Heat exchanger brazing)*10, Brass*10, Fluororesin, PP, PBT, POM, PU, PC, PVC, EPDM, NBR, Ion replacement resin*9 CH2: Stainless steel, Alumina ceramic, Carbon, Fluororesin, PP, PBT, POM, PU, PVC, PPS, AS, PS, EPDM, NBR, Ion replacement resin						
Power supply	3-phase 200 VAC (50 Hz), 3-phase 200 to 230 VAC (60 Hz) Allowable voltage range ±10% (No continuous voltage fluctuation)						
Earth leakage breaker	Rated current	A	30	40	50	—	
	Sensitivity current	mA	30			—	
	Rated operating current*4	A	17	32	41	—	
Rated power consumption*4	kW(kVA)	5.4 (5.9)	10.5 (11.0)	13.1 (14.2)	—	—	
Noise level (Front 1 m/Height 1 m)*4	dB(A)	75	75	75	71	—	
Accessories	Operation Manual (for installation/operation) 2 pcs. (English 1 pc./Japanese 1 pc.), Particle filter set for CH1, Particle filter set for CH2, Anchor bolt fixing brackets 2 pcs. (including 6 M8 bolts)*7						
Weight (dry state)*11	kg	Approx. 222		Approx. 251		Approx. 315	

- *1 Use fluid in condition below as the circulating fluid.
Tap water: please refer to "Specific Product Precautions".
Deionized water: Electric conductivity 1 μS/cm or higher (Electric resistivity 1 MΩ·cm or lower)
- *2 ① Ambient temperature: 32°C, ② Circulating fluid: Tap water, ③ Circulating fluid temperature: CH1 20°C/CH2 25°C, ④ Circulating fluid flow rate: Rated flow, ⑤ Power supply: 200 VAC
- *3 ① Ambient temperature: 32°C, ② Circulating fluid: Tap water, ③ Circulating fluid flow rate: Rated flow, ④ Power supply: 200 VAC
- *4 ① Ambient temperature: 32°C, ② Circulating fluid: Tap water, ③ Circulating fluid temperature: CH1 20°C/CH2 25°C, ④ Load: Same as the cooling capacity, ⑤ Circulating fluid flow rate: Rated flow, ⑥ Power supply: 200 VAC, ⑦ Piping length: Shortest
- *5 With the pressure control mode by inverter. If the pressure control

- mode is not necessary, use the flow control function or the pump output setting function.
- *6 Fluid flow rate to maintain the cooling capacity. If the actual flow rate is lower than this, adjust the bypass valve.
- *7 The anchor bolt fixing brackets (including 6 M8 bolts) are used for fixing to wooden skids when packaging the thermo-chiller. No anchor bolt is included.
- *8 Max. 1.5 kW. When 1.5 kW is applied, the cooling capacity of CH1 decreases by 0.5 kW.
- *9 For Option D1 (With electric conductivity control) only
- *10 Not included for Option D1 (With electric conductivity control)
- *11 The product weight increases by 1 kg for Option D1 (With electric conductivity control).



How to Order

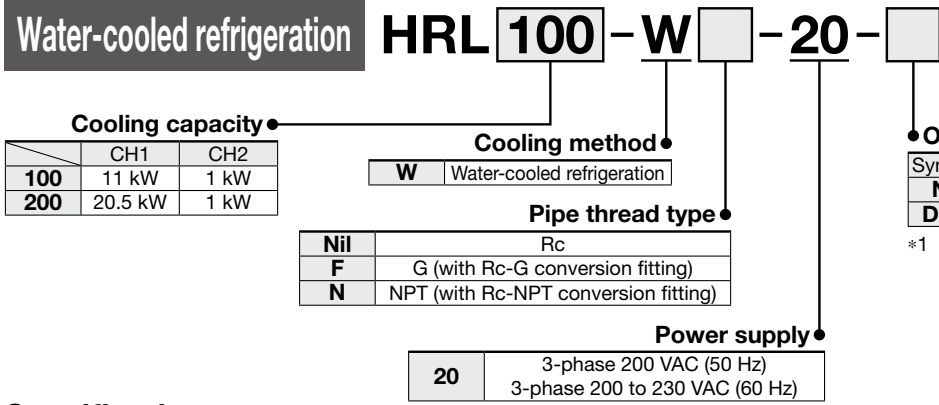

Option

Symbol	Options
Nil	CH2 Electric conductivity control
D1*1	CH1, CH2 Electric conductivity control

*1 CH2 has electric conductivity control as standard.

Specifications

Model	HRL100-W[]-20				HRL200-W[]-20				
	CH1		CH2		CH1		CH2		
Cooling method	Water-cooled refrigeration								
Refrigerant	R410A (HFC)								
Refrigerant charge	2 kg								
Control method	PID control								
Ambient temperature	2 to 45 °C								
Circulating fluid*1	CH1: Tap water*1, Deionized water*9/CH2: Tap water*1, Deionized water								
Set temperature range	CH1: 5 to 35/CH2: 10 to 40 °C								
Cooling capacity*2	11 kW		1*8 kW		20.5 kW		1*8 kW		
Heating capacity*3	4 kW		1 kW		4 kW		1 kW		
Temperature stability*4	CH1: ±0.1/CH2: ±0.5 °C								
Pump capacity	Rated flow (Outlet pressure)	45 (0.43 MPa) L/min		10 (0.45 MPa) L/min		45 (0.45 MPa) L/min		10 (0.45 MPa) L/min	
	Maximum flow rate	120 L/min		16*12 L/min		130 L/min		16*12 L/min	
	Maximum pump head	50 m		49 m		55 m		49 m	
Settable pressure range*5	0.10 to 0.50 MPa		0.10 to 0.49 MPa		0.10 to 0.55 MPa		0.10 to 0.49 MPa		
Minimum operating flow rate*6	20 L/min		2 L/min		25 L/min		2 L/min		
Tank capacity	42 L		7 L		42 L		7 L		
Bypass circuit (With valve)	Installed								
Electric conductivity setting range	0.5 to 45*9 μS/cm		0.5 to 45 μS/cm		0.5 to 45*9 μS/cm		0.5 to 45 μS/cm		
Particle filter nominal filtration rating (Accessory)	5 μm		5 μm		5 μm		5 μm		
Circulating fluid outlet, circulating fluid return port	CH1: Rc1 (Symbol F: G1, Symbol N: NPT1)/CH2: Rc1/2 (Symbol F: G1/2, Symbol N: NPT1/2)								
Tank drain port	CH1: Rc3/4 (Symbol F: G3/4, Symbol N: NPT3/4)/CH2: Rc1/2 (Symbol F: G1/2, Symbol N: NPT1/2)								
Fluid contact material	CH1: Stainless steel, Copper (Heat exchanger brazing)*10, Brass*10, Bronze*10, Fluororesin, PP, PBT, POM, PU, PC, PVC, EPDM, NBR, Ion replacement resin*9 CH2: Stainless steel, Alumina ceramic, Carbon, Fluororesin, PP, PBT, POM, PU, PVC, PPS, AS, PS, EPDM, NBR, Ion replacement resin								
Temperature range	5 to 40 °C								
Pressure range	0.3 to 0.5 MPa								
Required flow rate*12	25 L/min				50 L/min				
Inlet-outlet pressure differential of facility water	0.3 or more MPa								
Facility water inlet/outlet	Rc1 (Symbol F: G1, Symbol N: NPT1)								
Port size	Rc1 (Symbol F: G1, Symbol N: NPT1)								
Fluid contact material	Stainless steel, Copper (Heat exchanger brazing), Bronze, Brass, PTFE, NBR, EPDM								
Power supply	3-phase 200 VAC (50 Hz), 3-phase 200 to 230 VAC (60 Hz) Allowable voltage range ±10% (No continuous voltage fluctuation)								
Electrical system	Earth leakage breaker	Rated current	40 A						
		Sensitivity current	30 mA						
		Rated operating current*4	15.5 A		24.7 A				
	Rated power consumption*4	4.8 (5.4) kW (kVA)		7.9 (8.5) kW (kVA)					
Noise level (Front 1 m/Height 1 m)*4	61 dB (A)								
Accessories	Operation Manual (for installation/operation) 2 pcs. (English 1 pc./Japanese 1 pc.), Particle filter set for CH1, Particle filter set for CH2, Anchor bolt fixing brackets 2 pcs. (including 6 M8 bolts)*7								
Weight (dry state)*11	235 kg								

*1 Use fluid in condition below as the circulating fluid.
Tap water: please refer to "Specific Product Precautions".
Deionized water: Electric conductivity 1 μS/cm or higher (Electric resistivity 1 MΩ·cm or lower)

*2 ① Ambient temperature: 32°C, ② Circulating fluid: Tap water, ③ Circulating fluid temperature: CH1 20°C/CH2 25°C, ④ Circulating fluid flow rate: Rated flow, ⑤ Power supply: 200 VAC

*3 ① Ambient temperature: 32°C, ② Circulating fluid: Tap water, ③ Circulating fluid flow rate: Rated flow, ④ Power supply: 200 VAC

*4 ① Ambient temperature: 32°C, ② Circulating fluid: Tap water, ③ Circulating fluid temperature: CH1 20°C/CH2 25°C, ④ Load: Same as the cooling capacity, ⑤ Circulating fluid flow rate: Rated flow, ⑥ Power supply: 200 VAC, ⑦ Piping length: Shortest

*5 With the pressure control mode by inverter. If the pressure control mode is not necessary, use the flow control function or the pump output setting function.

*6 Fluid flow rate to maintain the cooling capacity. If the actual flow rate is lower than this, adjust the bypass valve.

*7 The anchor bolt fixing brackets (including 6 M8 bolts) are used for fixing to wooden skids when packaging the thermo-chiller. No anchor bolt is included.

*8 Max. 1.5 kW. When 1.5 kW is applied, the cooling capacity of CH1 decreases by 0.5 kW.

*9 For Option D1 (With electric conductivity control) only

*10 Not included for Option D1 (With electric conductivity control)

*11 The product weight increases by 1 kg for Option D1 (With electric conductivity control).

*12 The actual facility water flow rate will vary depending on the operating conditions.

Cooling Capacity

*1 This is the cooling capacity of the CH1 side when 1 kW heat load is applied to the CH2 side.
 *2 Max. 1.5 kW. When 1.5 kW is applied, the cooling capacity of CH1 decreases by 0.5 kW.

HRL100-A□-20 (CH1)*1

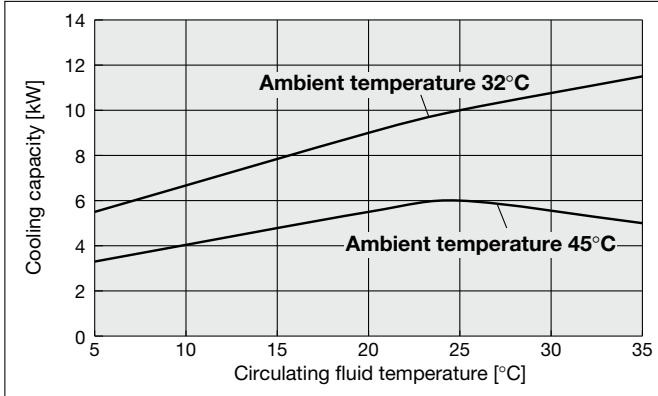

HRL100-W□-20 (CH1)

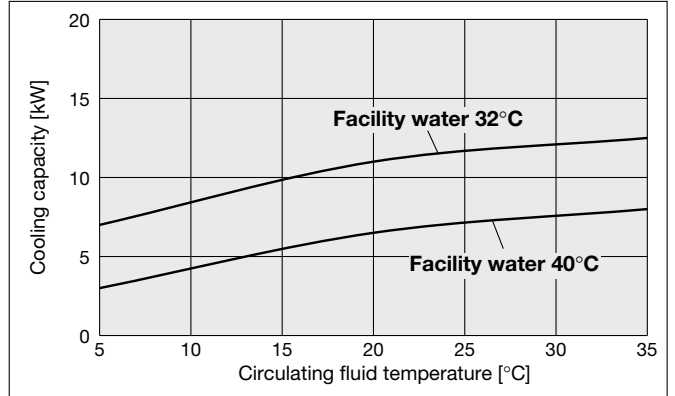

HRL200-A□-20 (CH1)*1

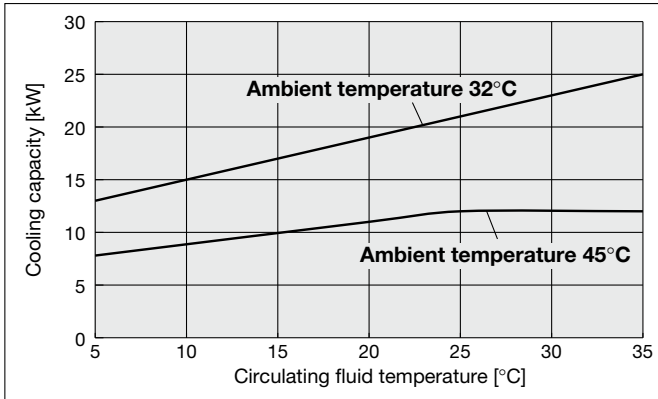

HRL200-W□-20 (CH1)

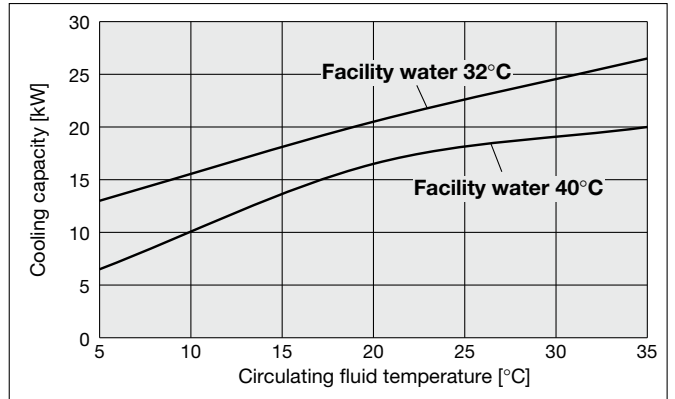

HRL300-A□-20 (CH1)*1

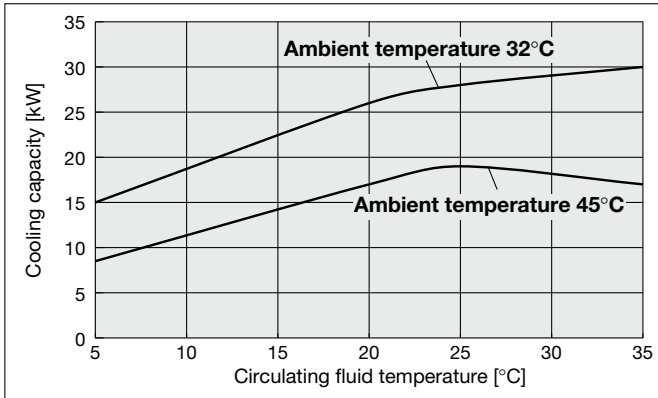

HRL100/200/300-A/W□-20 (CH2)

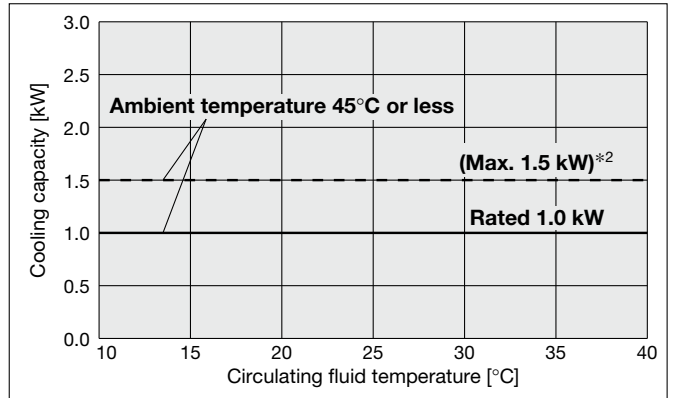

Pump Capacity

HRL100-A/W□-20 (CH1)

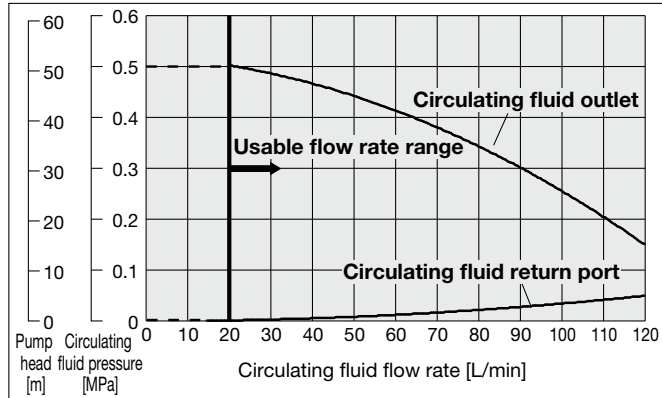

HRL200-A/W□-20 (CH1)

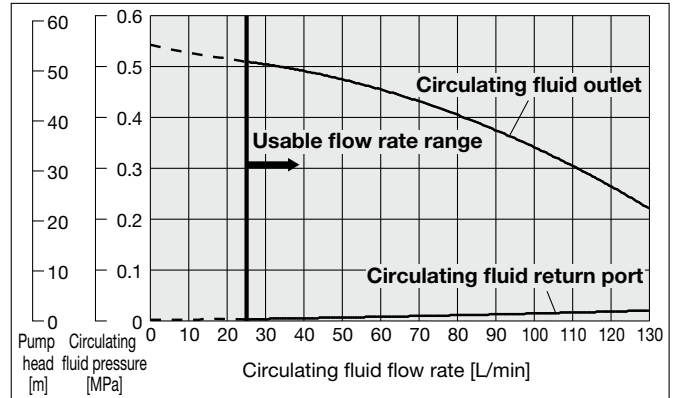

HRL300-A□-20 (CH1)

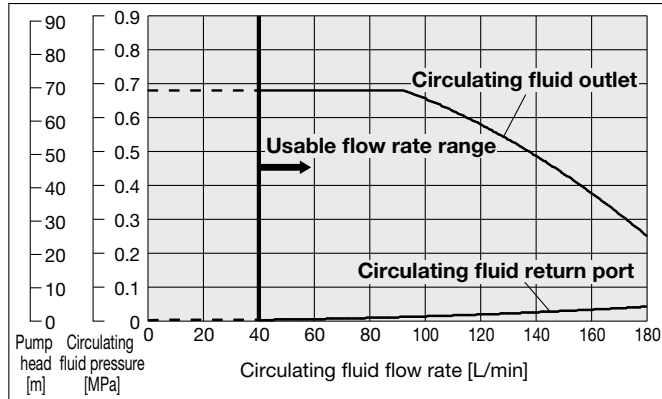

HRL100/200/300-A/W□-20 (CH2)

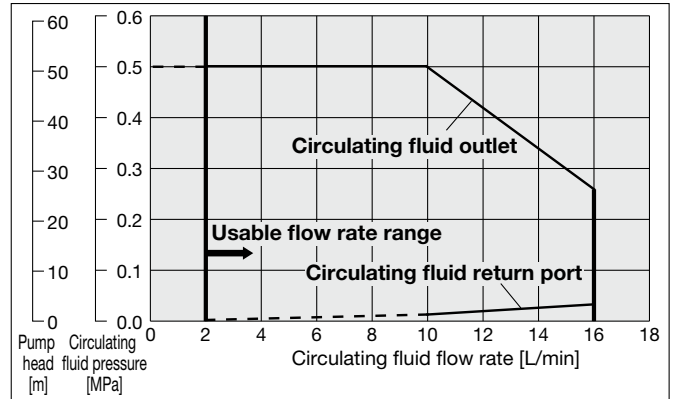

Dimensions

HRL100-A□-20

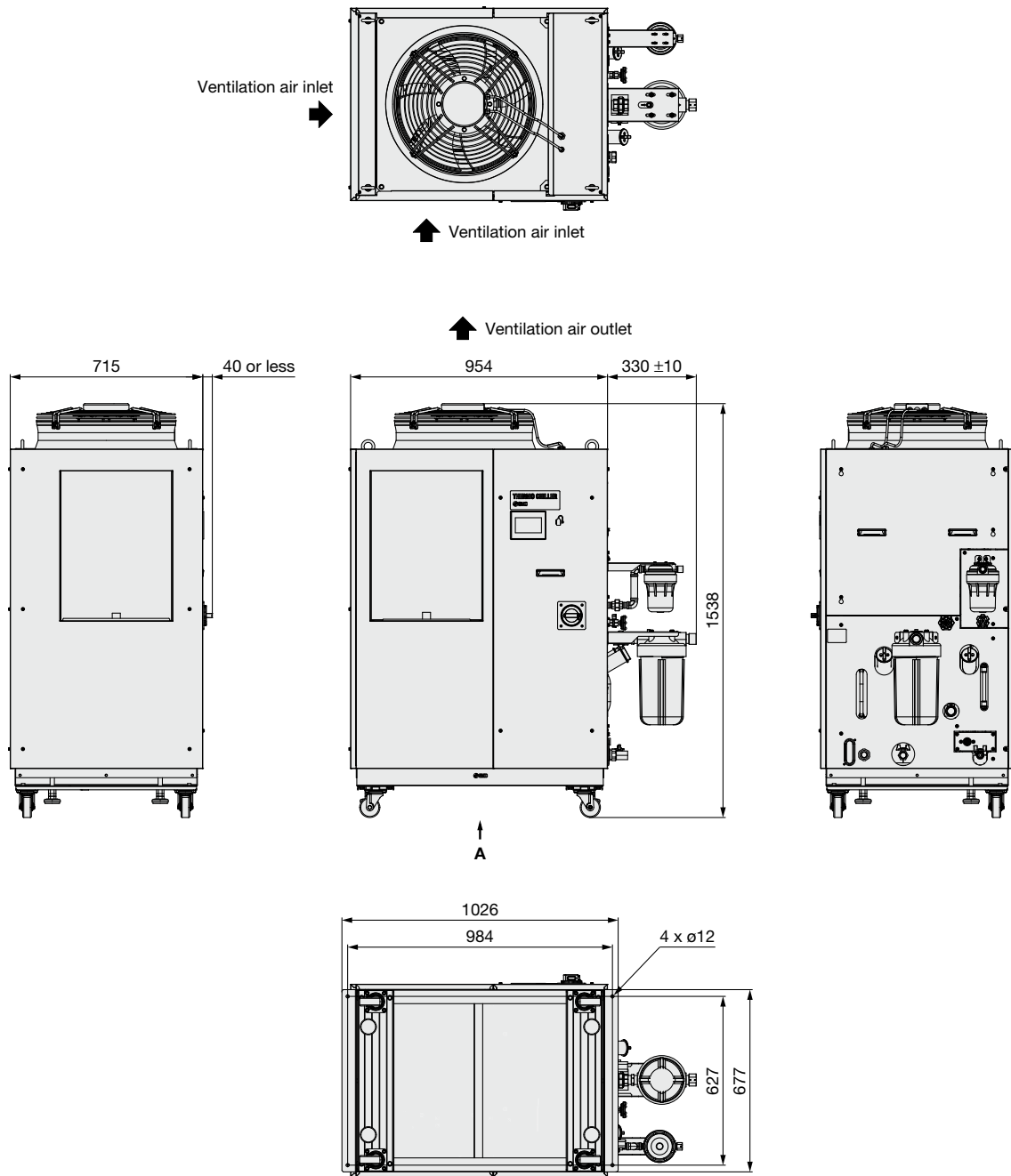

Anchor bolt mounting position (View A)

For piping port sizes, refer to the "Parts Description" on page 15.

Dimensions

HRL100/200-W□-20

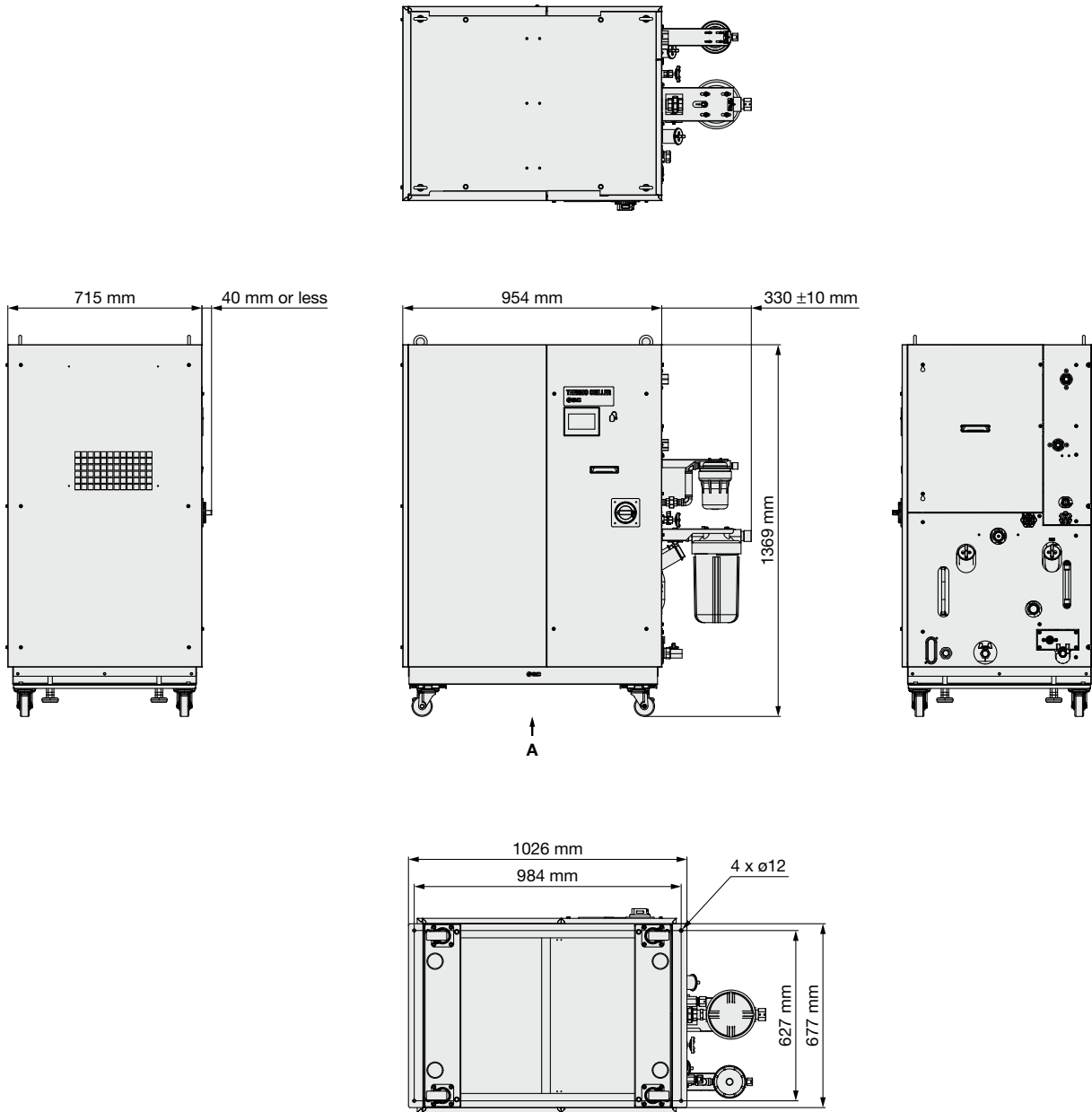

Anchor bolt mounting position (View A)

For piping port sizes, refer to the "Parts Description" on page 15.

Dimensions

HRL200-A□-20

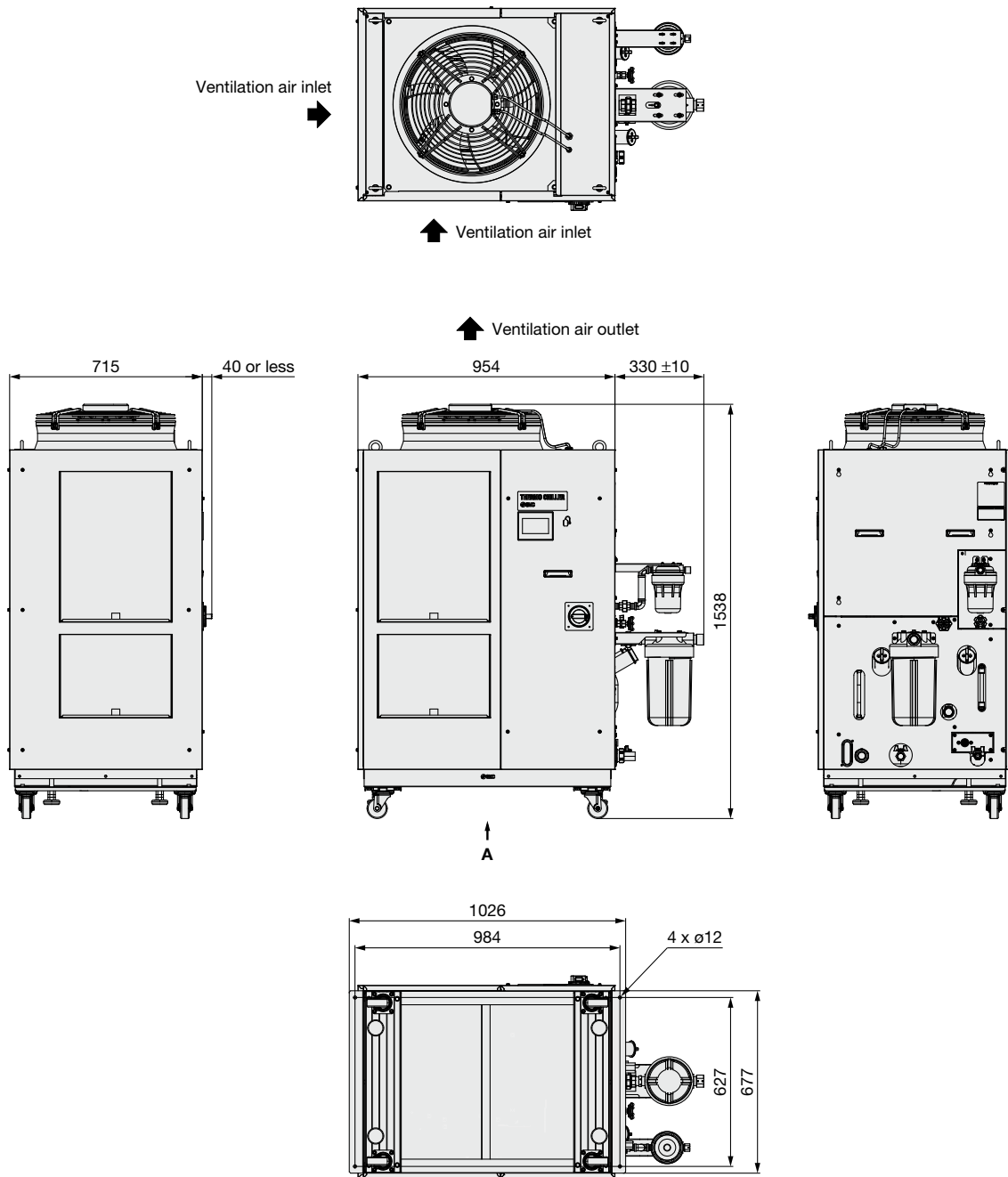

Anchor bolt mounting position (View A)

For piping port sizes, refer to the "Parts Description" on page 15.

Dimensions

HRL300-A□-20

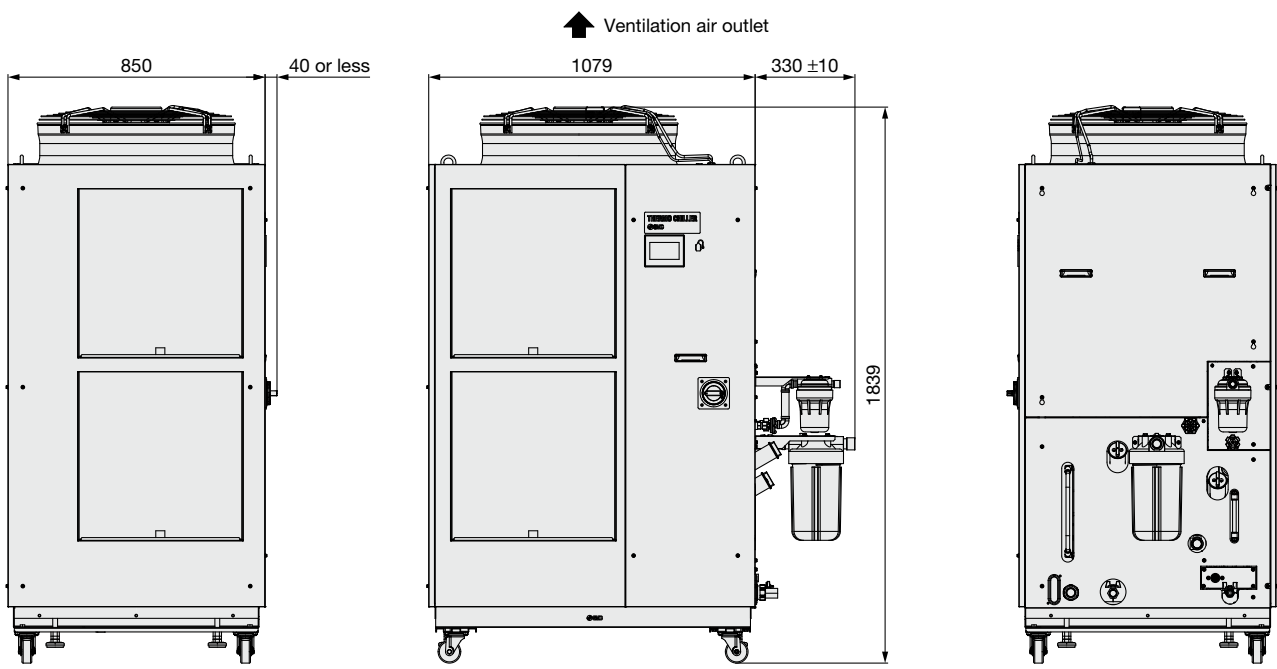
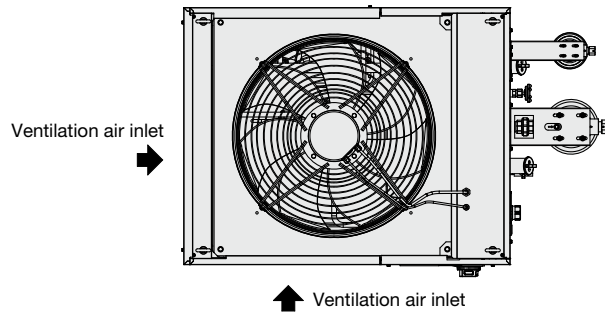

↑
A

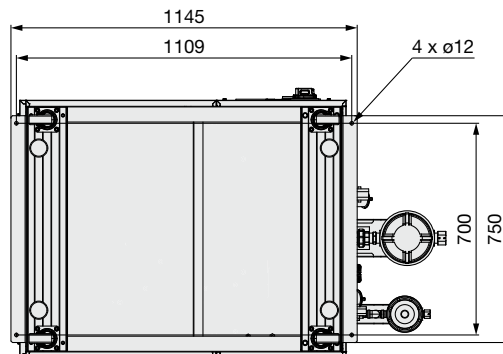

Anchor bolt mounting position (View A)

For piping port sizes, refer to the "Parts Description" on page 15.

Parts Description

Air-cooled refrigeration

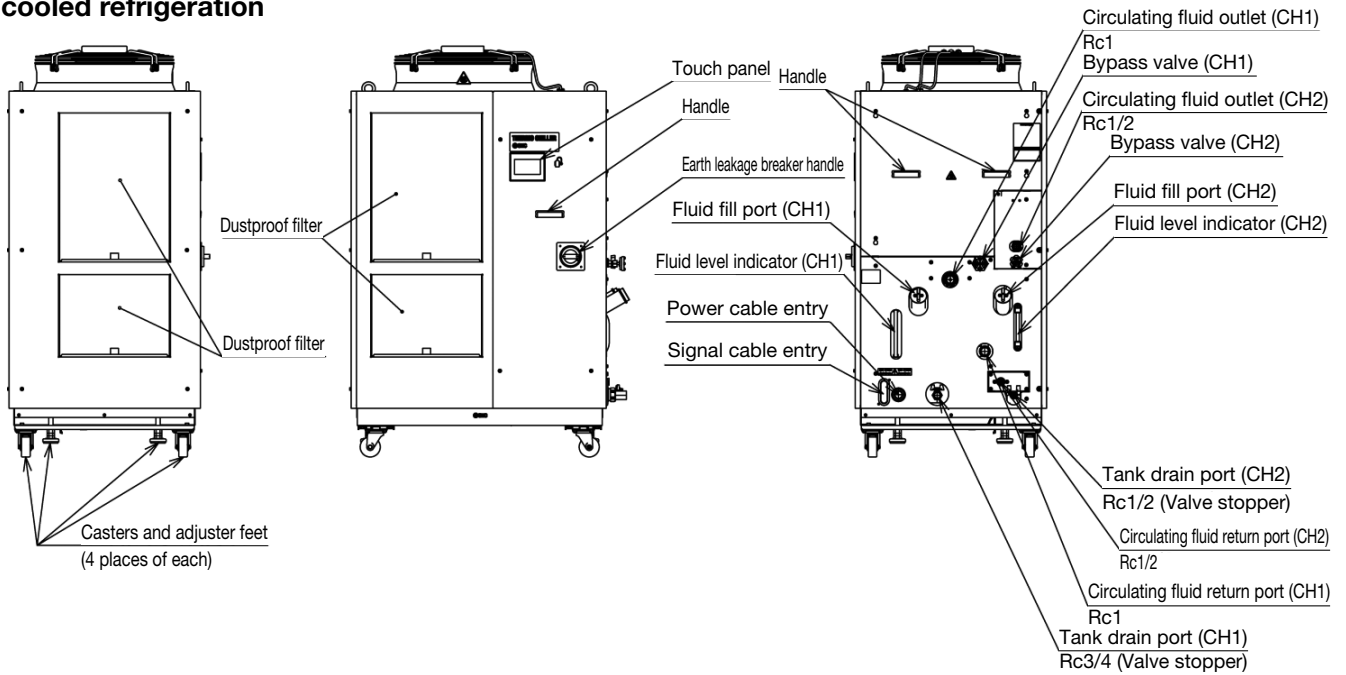

Water-cooled refrigeration

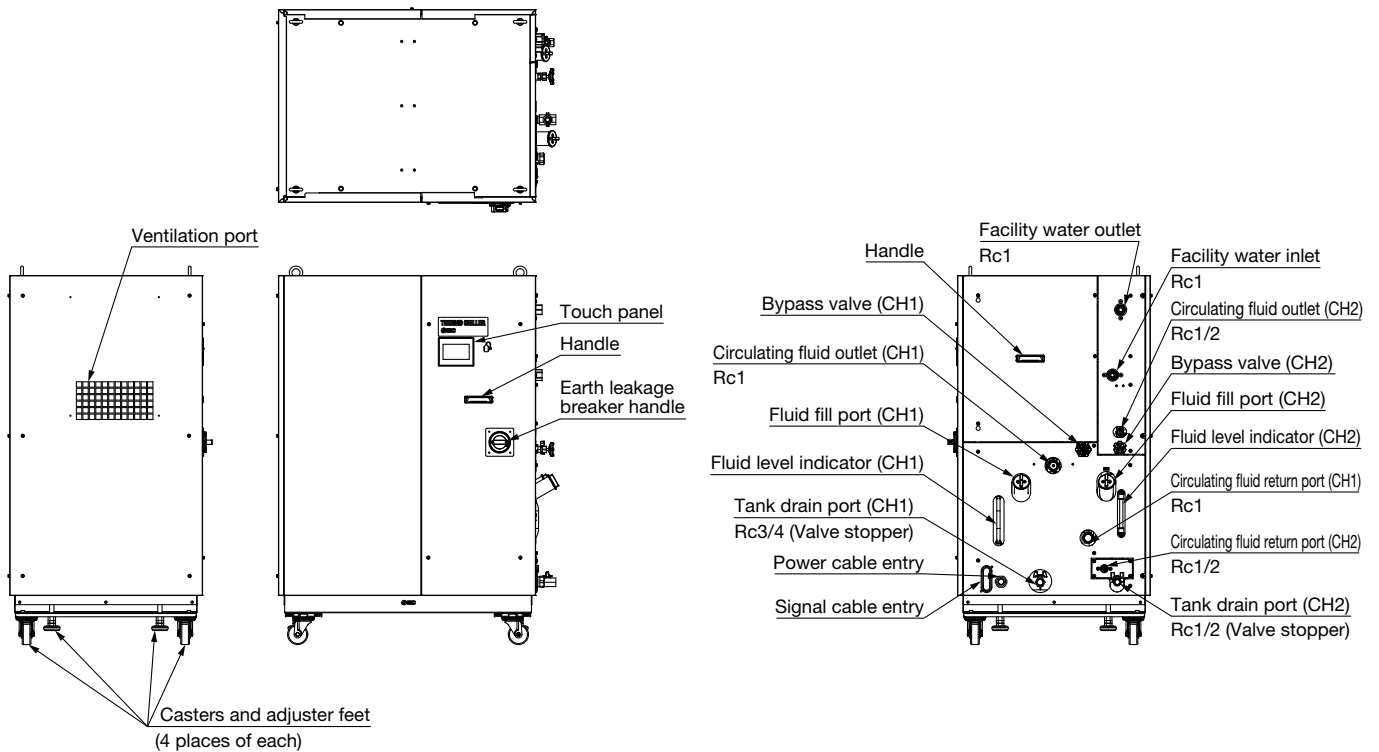

Thermo-chiller Dual Channel Thermo-chiller for Lasers

3-phase 380 to 415 VAC (50/60 Hz)
3-phase 460 to 480 VAC (60 Hz)



HRL Series



How to Order

Air-cooled refrigeration

HRL 100 - A - 40 -

	CH1	CH2
100	9 kW	1 kW
200	19 kW	1 kW
300	26 kW	1 kW
400	37 kW	1 kW

Cooling method	
A	Air-cooled refrigeration

Pipe thread type	
Nil	Rc
F	G (with Rc-G conversion fitting)
N	NPT (with Rc-NPT conversion fitting)

Power supply	
40	3-phase 380 to 415 VAC (50/60 Hz) 3-phase 460 to 480 VAC (60 Hz)

Symbol	Options
Nil	None
D1*1	CH1, CH2 Electric conductivity control
T2*2	CH2 High-pressure pump mounted (Max. cooling capacity: 3 kW)
T3*3	CH2 High-pressure pump mounted (Max. cooling capacity: 5 kW)

- *1 CH2 has electric conductivity control as standard.
- *2 For details, refer to "Options" on pages 33 and 34.
- *3 Option "T3" is only selectable for the HRL300/400. For details, refer to "Options" on page 35.

Specifications

Model	HRL100-A□-40		HRL200-A□-40		HRL300-A□-40		HRL400-A□-40		
	CH1	CH2	CH1	CH2	CH1	CH2	CH1	CH2	
Cooling method	Air-cooled refrigeration								
Refrigerant	R410A (HFC)								
Refrigerant charge kg	1.4		1.8		2.5		3.7		
Control method	PID control								
Ambient temperature °C	2 to 45								
Circulating fluid	CH1: Tap water*1, Deionized water*9/CH2: Tap water*1, Deionized water								
Set temperature range °C	CH1: 5 to 35/CH2: 10 to 40								
Cooling capacity *2 kW	9	1*8	19	1*8	26	1*8	37	1*8	
Heating capacity *3 kW	1.5	1	4.0	1	6.0	1	7.5	1	
Temperature stability *4 °C	CH1: ±0.1/CH2: ±0.5								
Pump capacity *13	Rated flow (Outlet pressure) L/min	45 (0.43 MPa)	10 (0.45 MPa)	45 (0.45 MPa)	10 (0.45 MPa)	125 (0.45 MPa)	10 (0.45 MPa)	125 (0.45 MPa)	10 (0.45 MPa)
	Maximum flow rate L/min	120	16*12	130	16*12	180	16*12	180	16*12
	Maximum pump head m	50	49	55	49	68	49	68	49
	Settable pressure range *5 MPa	0.10 to 0.50	0.10 to 0.49	0.10 to 0.55	0.10 to 0.49	0.10 to 0.68	0.10 to 0.49	0.10 to 0.68	0.10 to 0.49
Minimum operating flow rate *6 L/min	20	2	25	2	40	2	40	2	
Tank capacity *14 L	42	7	42	7	60	7	60	12	
Bypass circuit (With valve)	Installed								
Electric conductivity setting range μS/cm	0.5 to 45*9	0.5 to 45	0.5 to 45*9	0.5 to 45	0.5 to 45*9	0.5 to 45	0.5 to 45*9	0.5 to 45	
Particle filter nominal filtration rating (Accessory) μm	5	5	5	5	5	5	5	5	
Circulating fluid outlet, circulating fluid return port *14	CH1: Rc1 (Symbol F: G1, Symbol N: NPT1)/CH2: Rc1/2 (Symbol F: G1/2, Symbol N: NPT1/2)								
Tank drain port *14	CH1: Rc3/4 (Symbol F: G3/4, Symbol N: NPT3/4)/CH2: Rc1/2 (Symbol F: G1/2, Symbol N: NPT1/2)								
Fluid contact material	CH1: Stainless steel, Copper (Heat exchanger brazing)*10, Fluororesin, PP, PBT, POM, PU, PC, PVC, EPDM, NBR, FKM, Ion replacement resin*9 CH2: Stainless steel, Alumina ceramic, Carbon, Fluororesin, PP, PBT, POM, PU, PVC, PPS, AS, PS, EPDM, NBR, FKM, Ion replacement resin, PA*15								
Power supply	3-phase 380 to 415 VAC (50/60 Hz) Allowable voltage range ±10% (No continuous voltage fluctuation) 3-phase 460 to 480 VAC (60 Hz) Allowable voltage range +4%, -10% (Max. voltage less than 500 V and no continuous voltage fluctuation)								
Electrical system	Earth leakage breaker	20		30		40		40	
	Rated current A	20		30		40		40	
	Sensitivity current mA	30							
Rated operating current *4 A	8.5		15		19		23		
Rated power consumption *4 kW (kVA)	5.6 (5.9)		9.4 (10.2)		12.3 (13.0)		15.1 (16.0)		
Noise level (Front 1 m/Height 1 m) *4 dB (A)	75		75		71		71		
Accessories	Operation Manual (for installation/operation) 2 pcs. (English 1 pc./Japanese 1 pc.), Particle filter set for CH1, Particle filter set for CH2, Anchor bolt fixing brackets 2 pcs. (including 6 M8 bolts)*7								
Weight (dry state) *11 kg	Approx. 240		Approx. 260		Approx. 330		Approx. 380		

- *1 Use fluid in condition below as the circulating fluid.
Tap water: please refer to "Specific Product Precautions".
- *2 ① Ambient temperature: 32°C, ② Circulating fluid: Tap water,
③ Circulating fluid temperature: CH1 20°C/CH2 25°C, ④ Circulating fluid flow rate: Rated flow, ⑤ Power supply: 400 VAC
In the case of option T2 or T3 "CH2 High-Pressure Pump Mounted", refer to pages 33 to 35.
- *3 ① Ambient temperature: 32°C, ② Circulating fluid: Tap water,
③ Circulating fluid flow rate: Rated flow, ④ Power supply: 400 VAC
- *4 ① Ambient temperature: 32°C, ② Circulating fluid: Tap water,
③ Circulating fluid temperature: CH1 20°C/CH2 25°C, ④ Load: Same as the cooling capacity, ⑤ Circulating fluid flow rate: Rated flow, ⑥ Power supply: 400 VAC, ⑦ Piping length: Shortest
- *5 With the pressure control mode by inverter. If the pressure control mode is not necessary, use the flow control function or the pump output setting function.
- *6 Fluid flow rate to maintain the cooling capacity. If the actual flow rate is lower than this, adjust the bypass valve. In the case of option T2 or T3 "CH2 High-Pressure Pump Mounted", refer to pages 33 to 35.
- *7 The anchor bolt fixing brackets (including 6 M8 bolts) are used for fixing to wooden skids when packaging the thermo-chiller. No anchor bolt is included.
- *8 Max. 5 kW (for option "T3") However, if 1 kW is exceeded, the cooling capacity of CH1 will decrease by that amount.
- *9 For Option D1 (With electric conductivity control) only
- *10 Not included for Option D1 (With electric conductivity control)
- *11 The weight will increase by 1 kg when option "D1" (CH1, CH2 electric conductivity control) or option "T2" (CH2 high-pressure pump mounted) is selected. The weight will increase by 18 kg when option "T3" (CH2 high-pressure pump mounted) is selected for the HRL300, and 15 kg when it is selected for the HRL400.
- *12 The usable flow rate range is varied depending on the pump control mode. For details, refer to pump capacity curve on page 20.
- *13 In the case of option T2 or T3 "CH2 High-Pressure Pump Mounted", refer to pages 33 to 35.
- *14 In the case of option T3 "CH2 High-Pressure Pump Mounted", refer to page 35.
- *15 Included in options "T2" and "T3" as well as the HRL400



How to Order

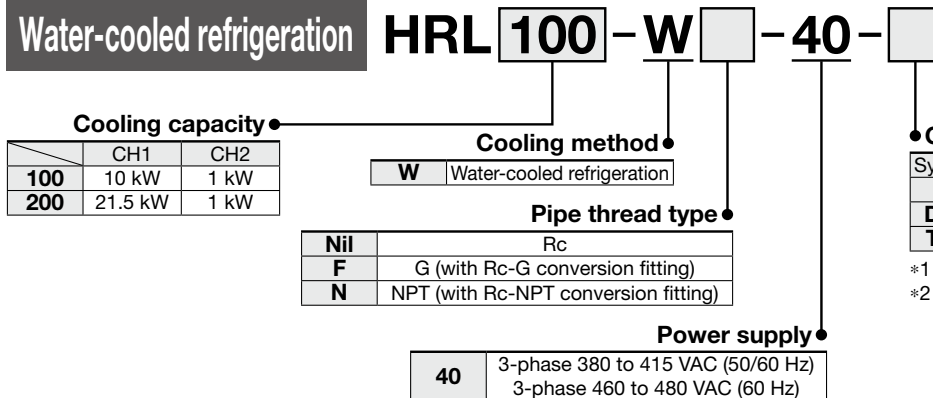

Specifications

Model	HRL100-W□-40		HRL200-W□-40	
	CH1	CH2	CH1	CH2
Cooling method	Water-cooled refrigeration			
Refrigerant	R410A (HFC)			
Refrigerant charge kg	1.8			
Control method	PID control			
Ambient temperature °C	2 to 45			
Circulating fluid	CH1: Tap water*1, Deionized water*9/CH2: Tap water*1, Deionized water			
Set temperature range °C	CH1: 5 to 35/CH2: 10 to 40			
Cooling capacity *2 kW	10	1*8	21.5	1*8
Heating capacity *3 kW	1.5	1	4.0	1
Temperature stability *4 °C	CH1: ±0.1/CH2: ±0.5			
Pump capacity *13	Rated flow (Outlet pressure) L/min	45 (0.43 MPa)	10 (0.45 MPa)	45 (0.45 MPa)
	Maximum flow rate L/min	120	16*12	130
	Maximum pump head m	50	49	55
Settable pressure range *5 MPa	0.10 to 0.50	0.10 to 0.49	0.10 to 0.55	0.10 to 0.49
Minimum operating flow rate *6 L/min	20	2	25	2
Tank capacity L	42	7	42	7
Bypass circuit (With valve)	Installed			
Electric conductivity setting range μS/cm	0.5 to 45*9	0.5 to 45	0.5 to 45*9	0.5 to 45
Particle filter nominal filtration rating (Accessory) μm	5	5	5	5
Circulating fluid outlet, circulating fluid return port	CH1: Rc1 (Symbol F: G1, Symbol N: NPT1)/CH2: Rc1/2 (Symbol F: G1/2, Symbol N: NPT1/2)			
Tank drain port	CH1: Rc3/4 (Symbol F: G3/4, Symbol N: NPT3/4)/CH2: Rc1/2 (Symbol F: G1/2, Symbol N: NPT1/2)			
Fluid contact material	CH1: Stainless steel, Copper (Heat exchanger brazing)*10, Fluororesin, PP, PBT, POM, PU, PC, PVC, EPDM, NBR, FKM, Ion replacement resin*9 CH2: Stainless steel, Alumina ceramic, Carbon, Fluororesin, PP, PBT, POM, PU, PVC, PPS, AS, PS, EPDM, NBR, Ion replacement resin, PA*14			
Temperature range °C	5 to 35			
Pressure range MPa	0.3 to 0.5			
Required flow rate *15 L/min	25		50	
Inlet-outlet pressure differential of facility water MPa	0.3 or more			
Facility water inlet/outlet	Rc1 (Symbol F: G1, Symbol N: NPT1)			
Port size	Rc1 (Symbol F: G1, Symbol N: NPT1)			
Fluid contact material	Stainless steel, Copper (Heat exchanger brazing), Bronze, Brass, PTFE, NBR, EPDM			
Power supply	3-phase 380 to 415 VAC (50/60 Hz) Allowable voltage range ±10% (No continuous voltage fluctuation) 3-phase 460 to 480 VAC (60 Hz) Allowable voltage range +4%, -10% (Max. voltage less than 500 V and no continuous voltage fluctuation)			
Earth leakage breaker	Rated current A	30		
	Sensitivity current mA	30		
Rated operating current *4 A	12.7		13.3	
Rated power consumption *4 kW (kVA)	7.9 (8.8)		8.6 (9.2)	
Noise level (Front 1 m/Height 1 m)*4 dB (A)	72			
Accessories	Operation Manual (for installation/operation) 2 pcs. (English 1 pc./Japanese 1 pc.), Particle filter set for CH1, Particle filter set for CH2, Anchor bolt fixing brackets 2 pcs. (including 6 M8 bolts)*7			
Weight (dry state)*11 kg	Approx. 250			

- *1 Use fluid in condition below as the circulating fluid.
Tap water: please refer to "Specific Product Precautions".
- *2 ① Facility water temperature: 32°C, ② Circulating fluid: Tap water, ③ Circulating fluid temperature: CH1 20°C/CH2 25°C, ④ Circulating fluid flow rate: Rated flow, ⑤ Power supply: 400 VAC
In the case of option T2 "CH2 High-Pressure Pump Mounted", refer to page 33 and 34.
- *3 ① Facility water temperature: 32°C, ② Circulating fluid: Tap water, ③ Circulating fluid flow rate: Rated flow, ④ Power supply: 400 VAC
- *4 ① Facility water temperature: 32°C, ② Circulating fluid: Tap water, ③ Circulating fluid temperature: CH1 20°C/CH2 25°C, ④ Load: Same as the cooling capacity, ⑤ Circulating fluid flow rate: Rated flow, ⑥ Power supply: 400 VAC, ⑦ Piping length: Shortest
- *5 With the pressure control mode by inverter. If the pressure control mode is not necessary, use the flow control function or the pump output setting function.
- *6 Fluid flow rate to maintain the cooling capacity. If the actual flow rate is lower than this, adjust the bypass valve. In the case of option T2 "CH2 High-Pressure Pump Mounted", refer to page 33 and 34.
- *7 The anchor bolt fixing brackets (including 6 M8 bolts) are used for fixing to wooden skids when packaging the thermo-chiller. No anchor bolt is included.
- *8 Max. 3 kW (for option "T2") However, if 1 kW is exceeded, the cooling capacity of CH1 will decrease by that amount.
- *9 For Option D1 (With electric conductivity control) only
- *10 Not included for Option D1 (With electric conductivity control)
- *11 The weight will increase by 1 kg when option D1 "With electrical conductivity control" and option T2 "CH2 High-Pressure Pump Mounted" is selected.
- *12 The usable flow rate range is varied depending on the pump control mode. For details, refer to pump capacity curve on page 20.
- *13 In the case of option T2 "CH2 High-Pressure Pump Mounted", refer to page 33 and 34.
- *14 Included in option "T2"
- *15 The actual facility water flow rate will vary depending on the operating conditions.

Cooling Capacity

*1 This is the cooling capacity of the CH1 side when 1 kW heat load is applied to the CH2 side.

*2 Max. 1.5 kW. When 1.5 kW is applied, the cooling capacity of CH1 decreases by 0.5 kW.

HRL100-A□-40 (CH1)*1

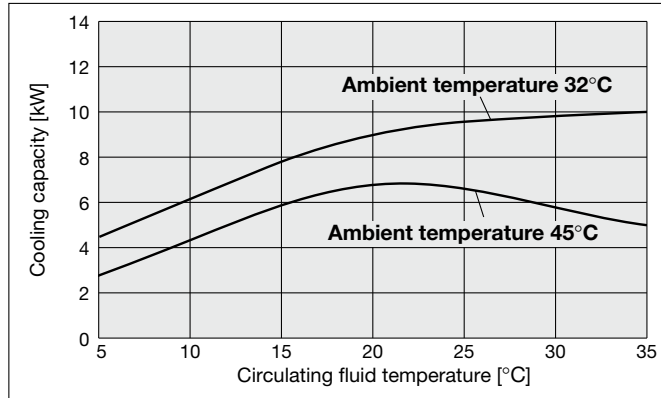

HRL100-W□-40 (CH1)*1

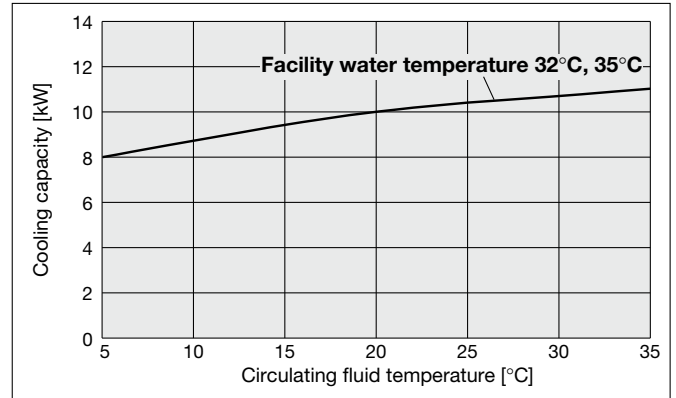

HRL200-A□-40 (CH1)*1

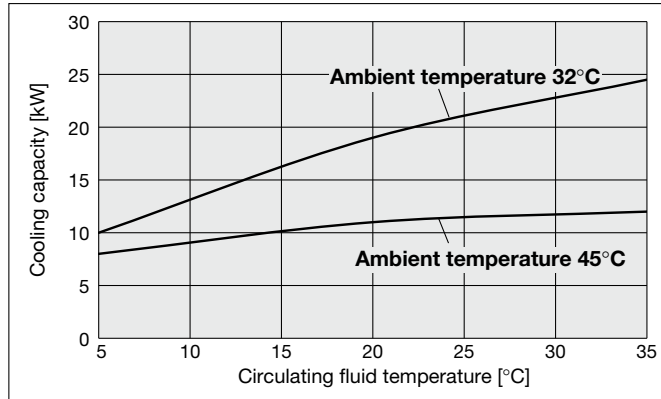

HRL200-W□-40 (CH1)*1

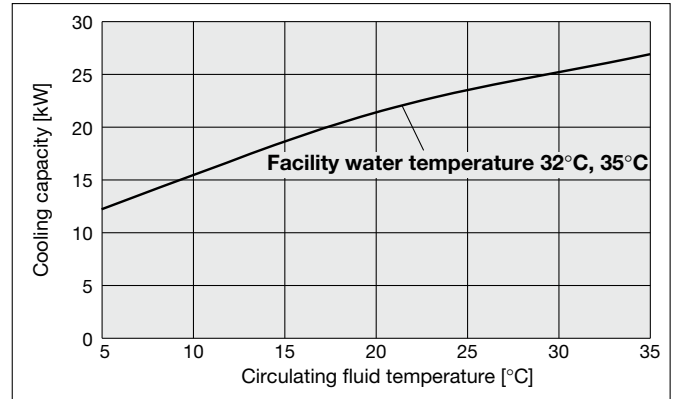

HRL300-A□-40 (CH1)*1

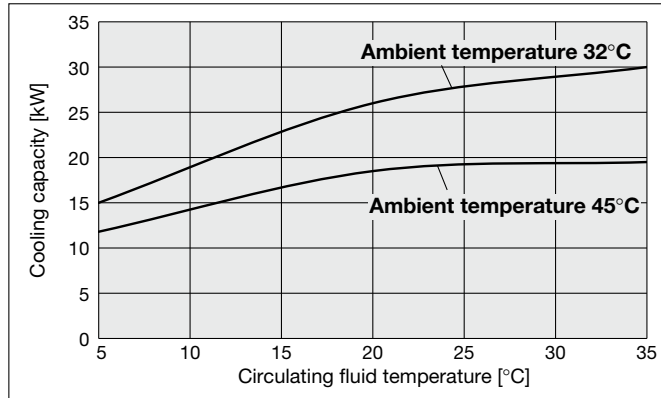

HRL100/200/300/400-A/W□-40 (CH2)*2

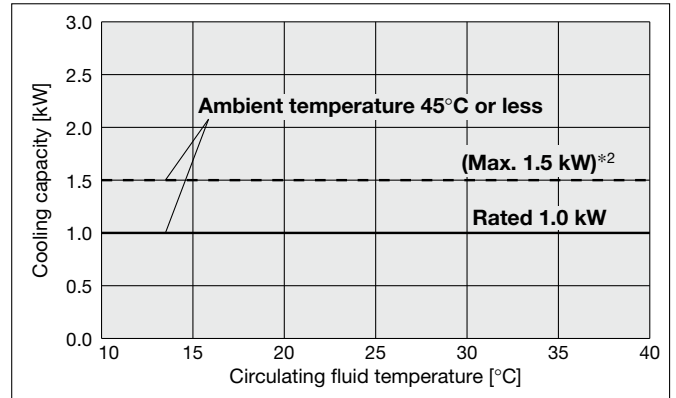

HRL400-A□-40 (CH1)*1

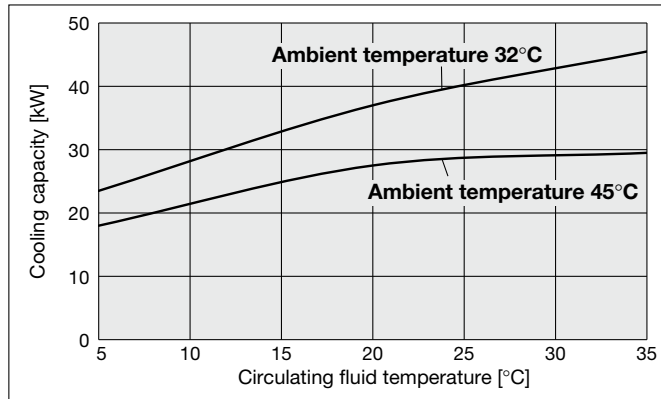

Pump Capacity

HRL100-A/W□-40 (CH1)

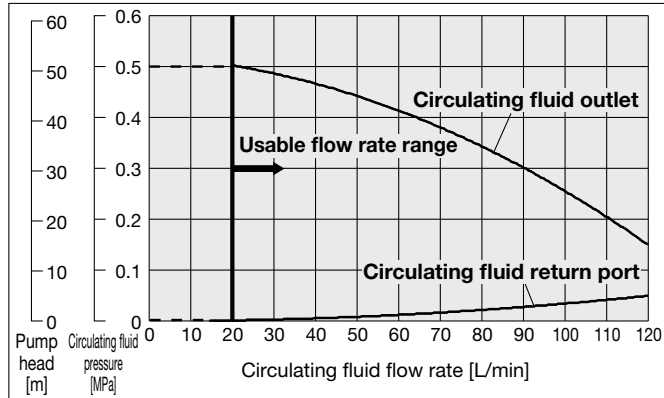

HRL200-A/W□-40 (CH1)

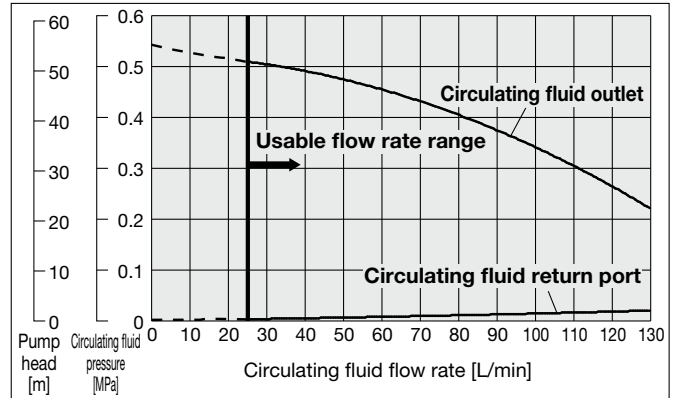

HRL300/400-A□-40 (CH1)

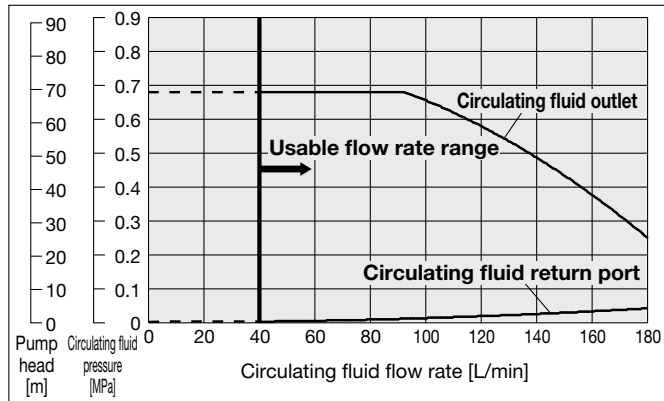

HRL100/200/300/400-A/W□-40 (CH2)

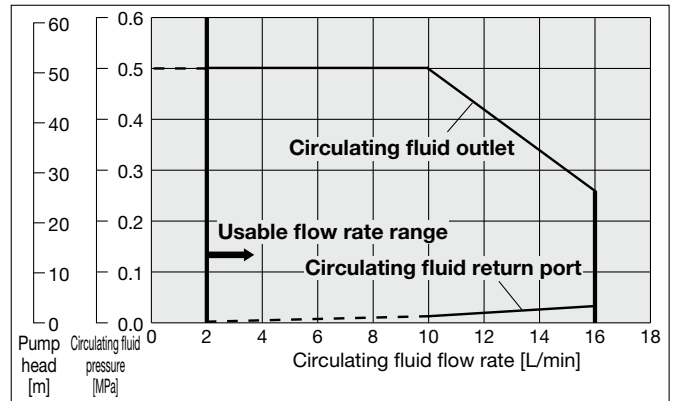

Dimensions

HRL100-A□-40

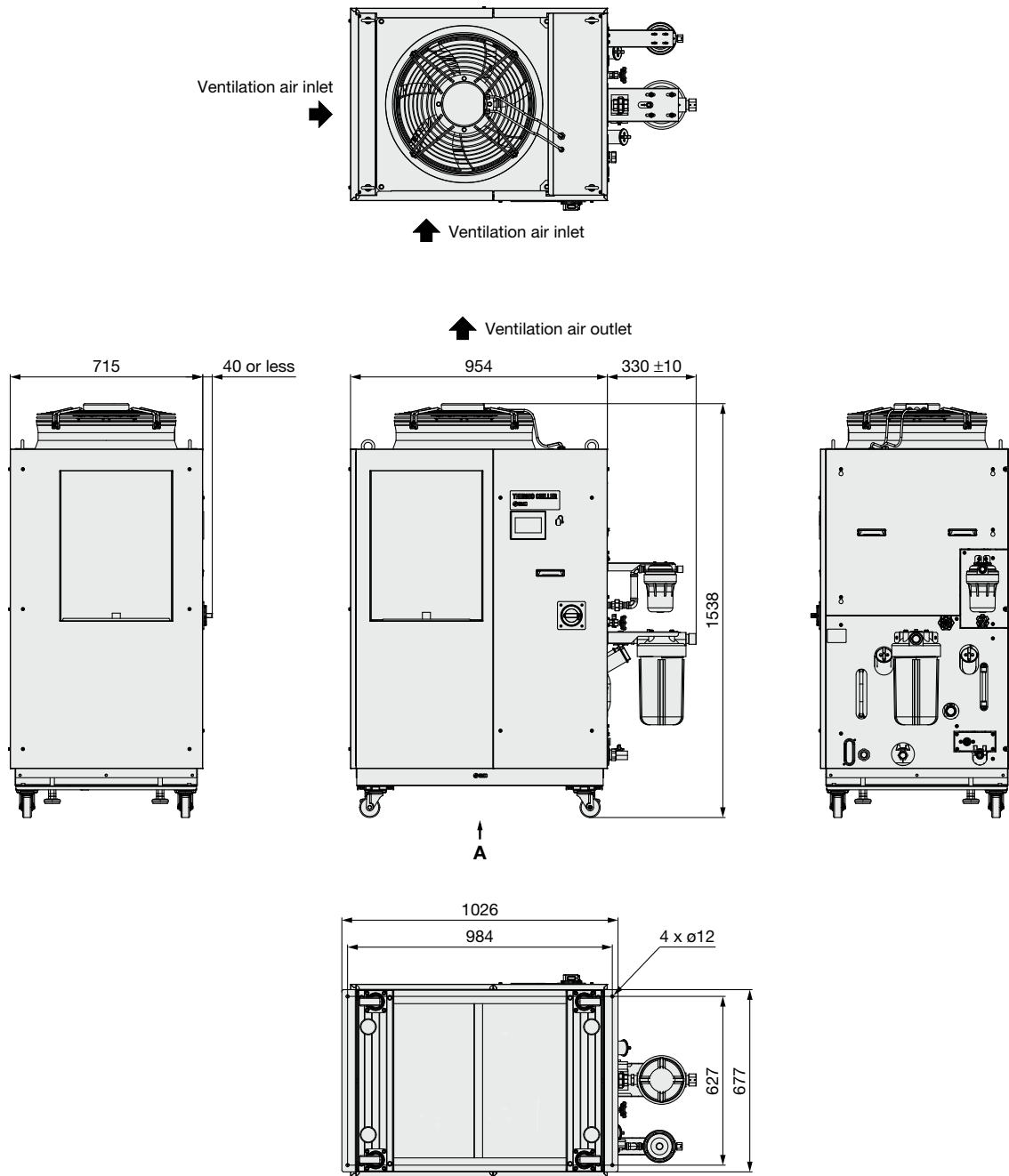

Anchor bolt mounting position (View A)

For piping port sizes, refer to the "Parts Description" on page 26.

Dimensions

HRL100/200-W□-40

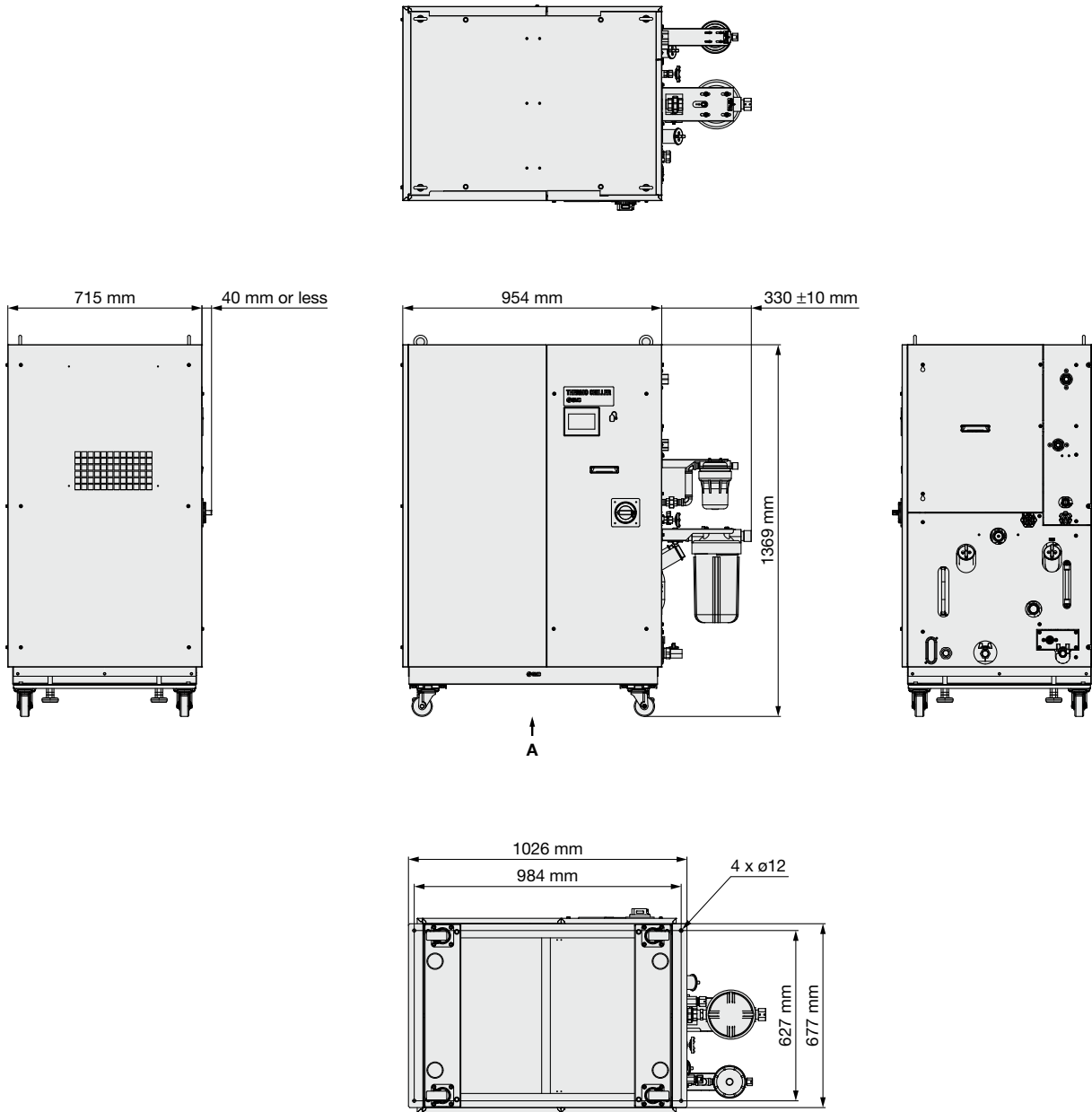

Anchor bolt mounting position (View A)

For piping port sizes, refer to the "Parts Description" on page 26.

Dimensions

HRL200-A□-40

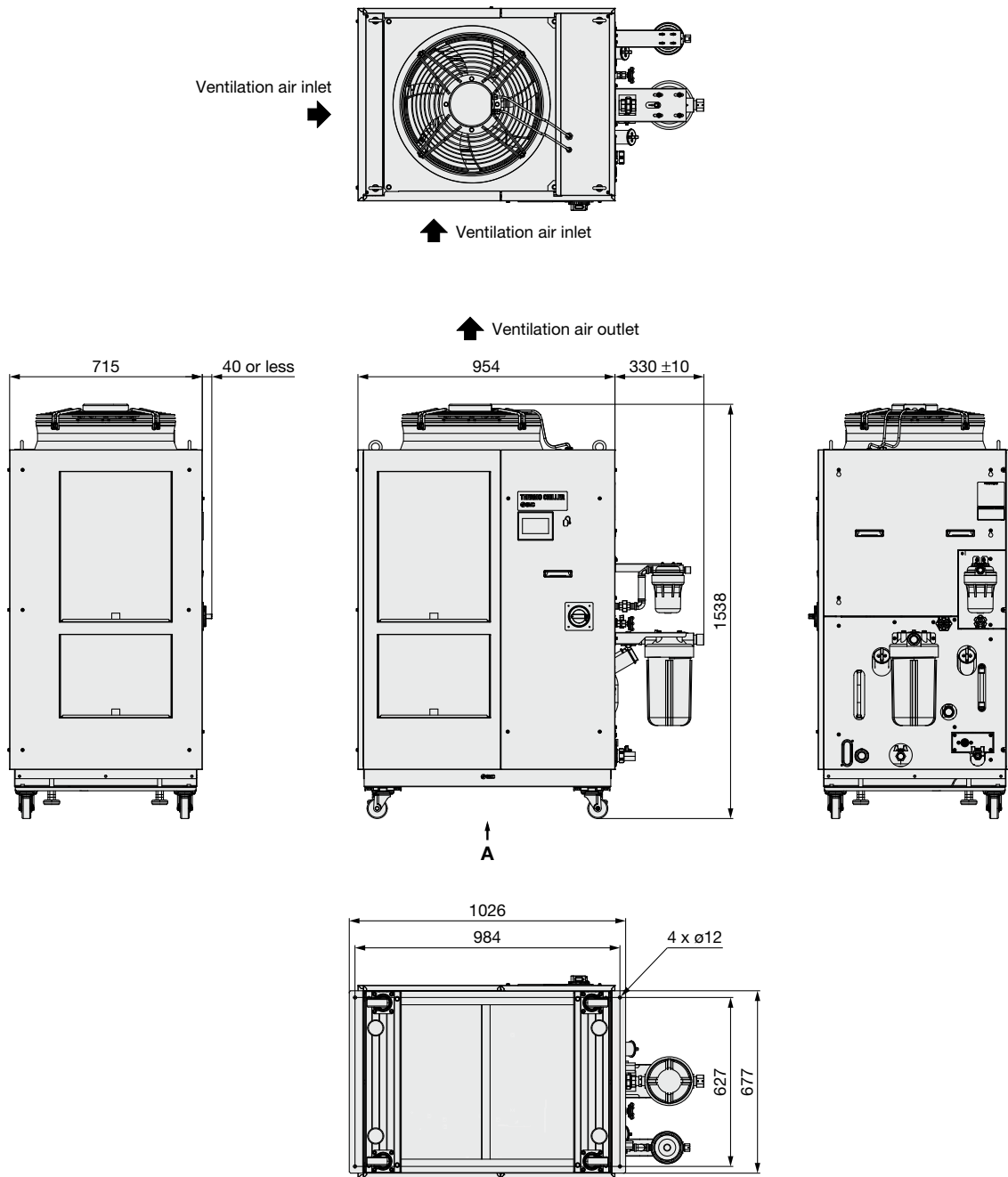

Anchor bolt mounting position (View A)

For piping port sizes, refer to the "Parts Description" on page 26.

Dimensions

HRL300-A□-40

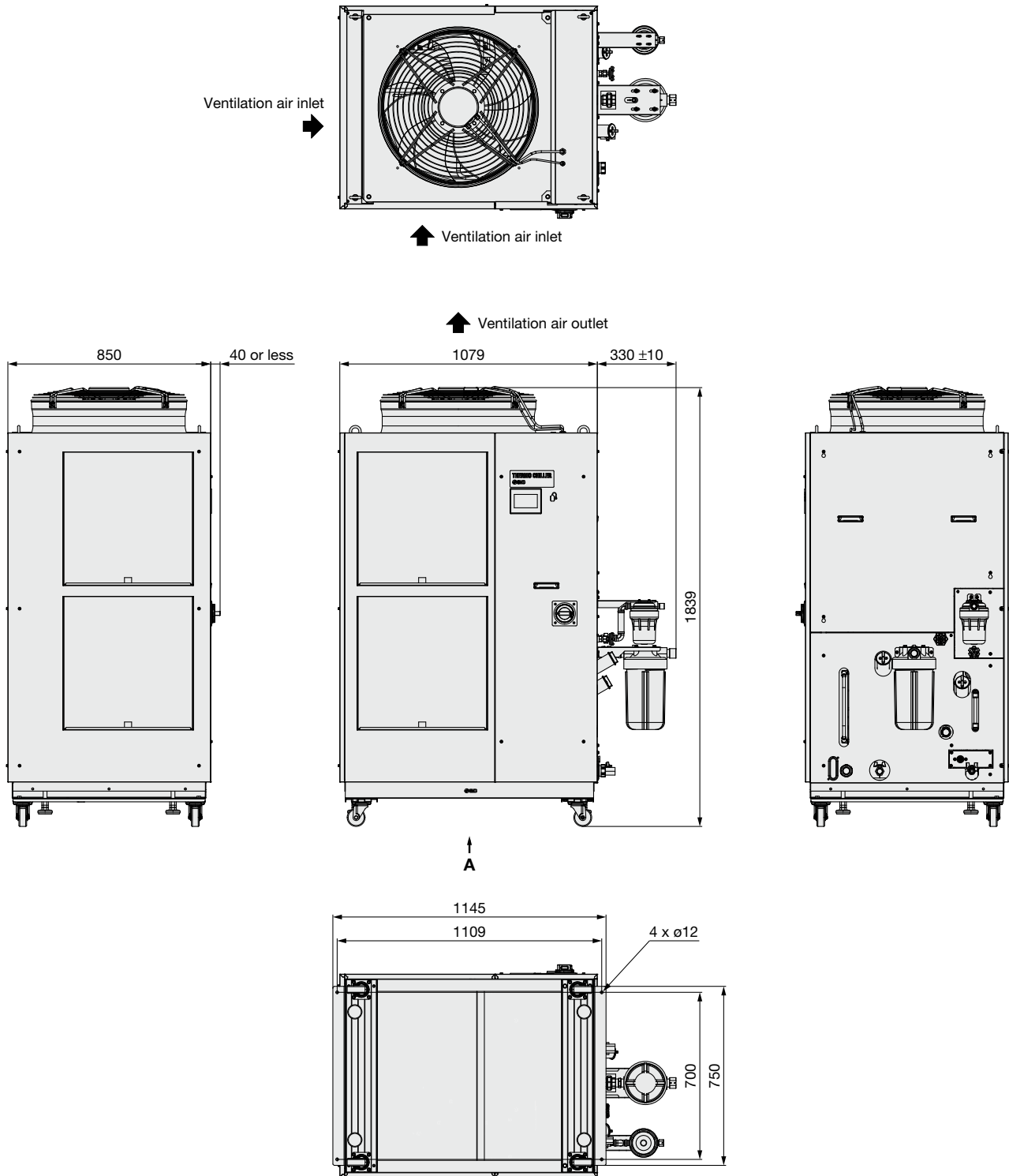

Anchor bolt mounting position (View A)

For piping port sizes, refer to the "Parts Description" on page 26.

Dimensions

HRL400-A□-40

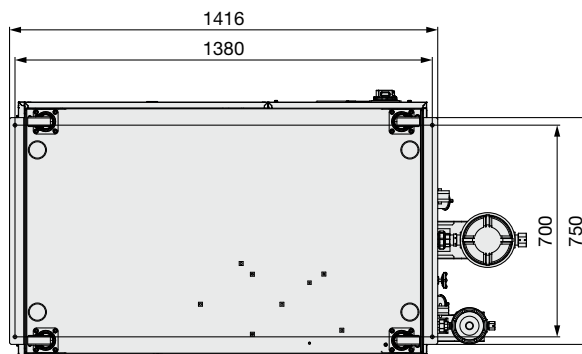
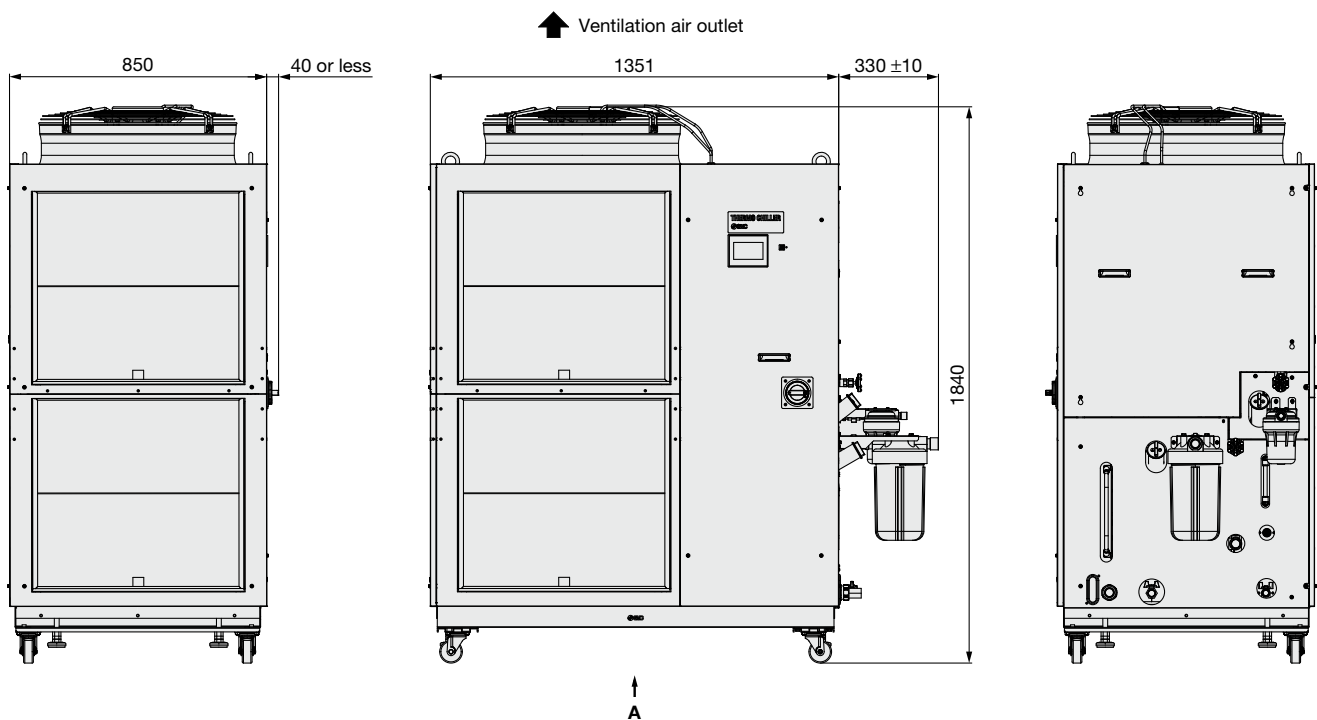
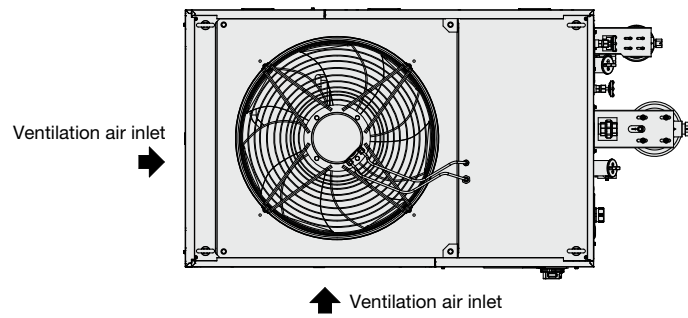

Anchor bolt mounting position (View A)

For piping port sizes, refer to the "Parts Description" on page 26.

Parts Description

Air-cooled refrigeration

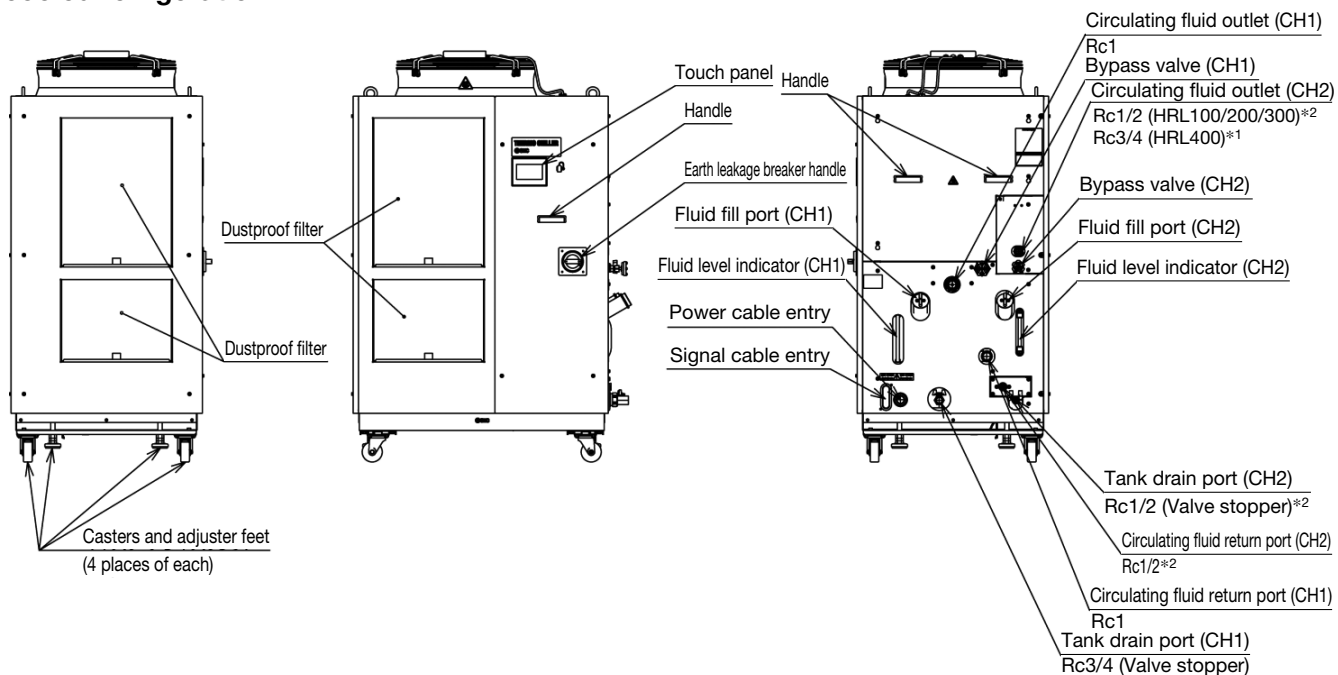

*1 When connecting a particle filter, the port size will be Rc1/2.*2
 *2 For option "T3," the piping size varies. For details, refer to page 423.

Water-cooled refrigeration

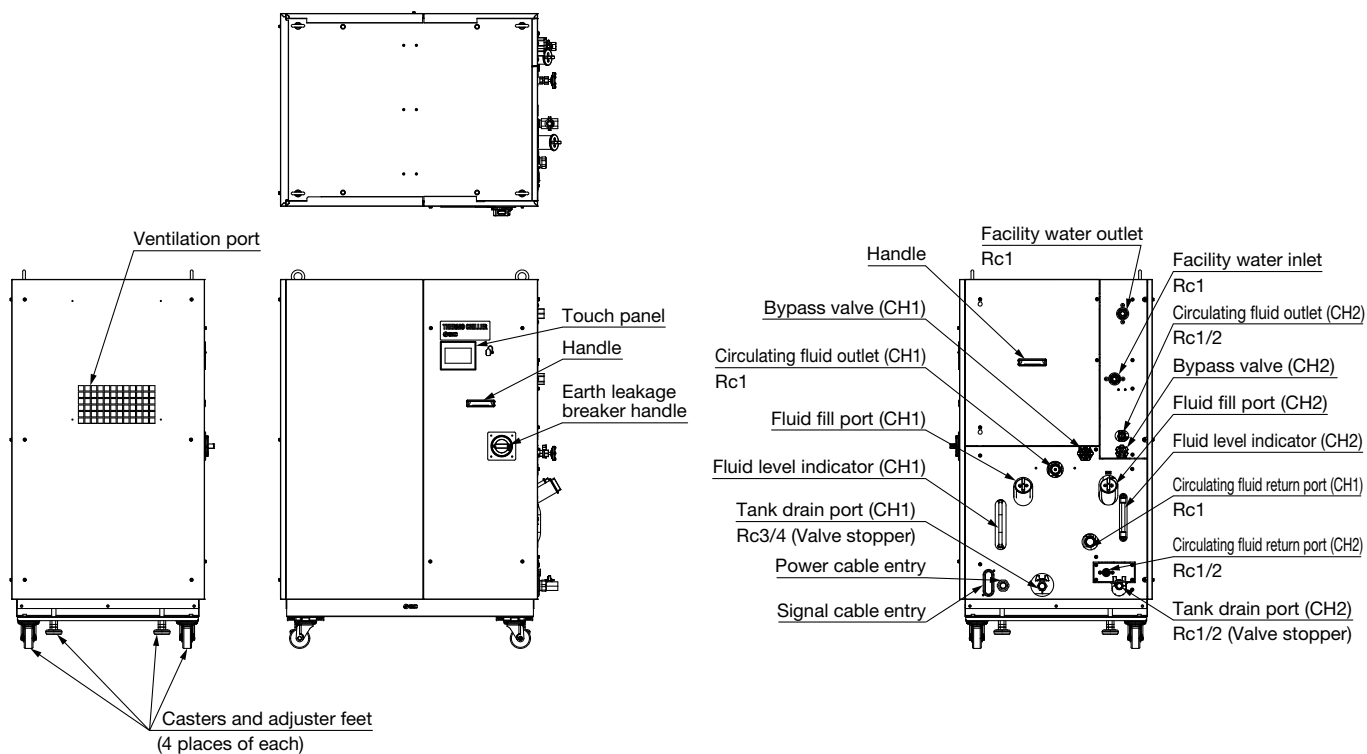

Recommended External Piping Flow

External piping circuit is recommended as shown below.

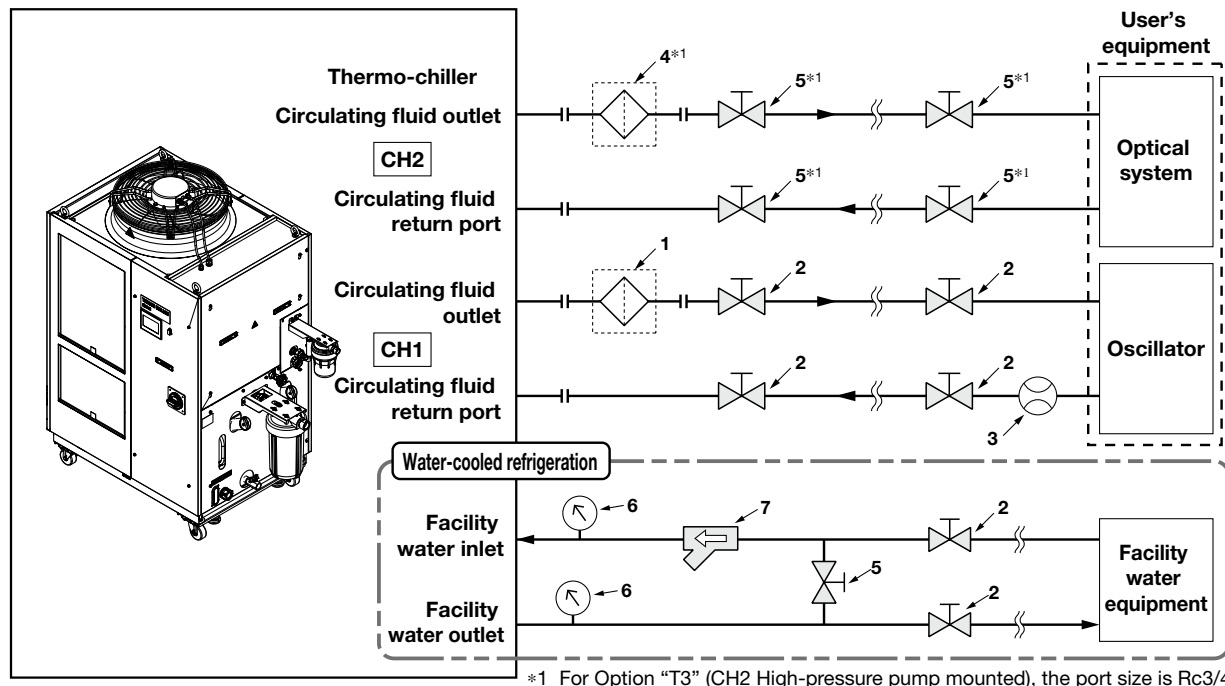

No.	Description	Size	Recommended part no.	Note
1	Particle filter	Rc1 (5 μm)	Accessory	The value in () shows the nominal filtration accuracy.
2	Valve	Rc1	—	—
3	Flow meter	Rc1	—	Prepare a flow meter with an appropriate flow range.
4	Particle filter	Rc1/2 (5 μm)	Accessory	The value in () shows the nominal filtration accuracy.
5	Valve	Rc1/2	—	—
6	Pressure gauge	0 to 1.0 MPa	—	—
7	Y-strainer	Rc1 #40	HRS-S0212	Install either the strainer or filter. If foreign matter with a size of 20 μm or more are likely to enter, install the particle filter. For the recommended filter, refer to the table below (*1).
	Filter	Rc1 (20 μm)	Refer to the table below	

*1 Recommended filters for facility water inlet

Applicable model	Recommended filter
HRL100	FQ1012N-10-T020-B-X61
HRL200	FGESA-10-T020A-G2

*2 The filter shown above cannot be directly connected to the thermo-chiller. Install it in the user's piping system.

Cable Specifications

Power Supply Cable and Earth Leakage Breaker (Recommended)

Model	Power supply voltage specifications	Terminal block screw diameter	Recommended crimped terminal	Cable specifications*1	Earth leakage breaker	
					Breaker size [A]	Sensitivity current [mA]
HRL100-A□-20	3-phase 200 VAC (50 Hz) 3-phase 200 to 230 VAC (60 Hz)	M5	R5.5.5	4 cores x 5.5 mm ² (4 cores x AWG 10) * Including grounding cable	30	30
HRL100-W□-20					40	
HRL200-A□-20			50			
HRL200-W□-20			20			
HRL100-A□-40	3-phase 380 to 415 VAC (50/60 Hz) 3-phase 460 to 480 VAC (60 Hz)	M5	R5.5-5	4 cores x 5.5 mm ² (4 cores x AWG 10) * Including grounding cable	30	30
HRL200-A□-40					40	
HRL100/200-W□-40			40			
HRL300-A□-40 HRL400-A□-40			30			

*1 An example of the cable specifications is when two kinds of vinyl insulated wires with a continuous allowable operating temperature of 70°C at 600 V, are used at an ambient temperature of 30°C. Select the proper size of cable according to an actual condition.

Operation Display Panel

Items displayed on the home screen and setting items are shown in List of check items in inspection monitor menu.

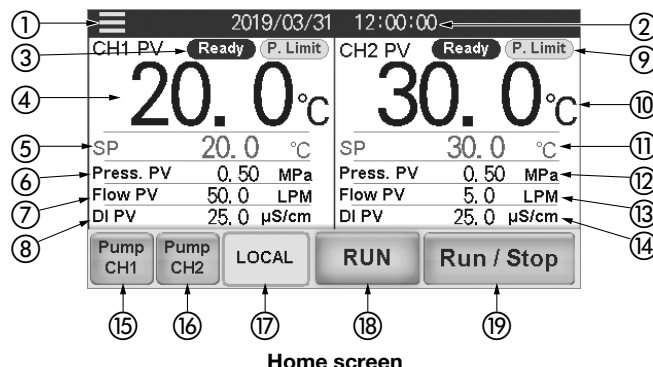

List of Check Items in Inspection Monitor Menu

No.	CH no.	Item	Explanation
①	Common	Menu key	Touch the key to display the menu.
②		Date and time display	Displays the date and time. Press the numeric section to set the date and time.
③	CH1	Operating condition display	Displays TEMP READY status. Displays the control status of the circulating fluid pressure.
④		Circulating fluid present temperature	Displays the current temperature of circulating fluid.
⑤		Circulating fluid set temperature	It indicates the set temperature. Press the numeric section to change the set temperature
⑥		Circulating fluid discharge pressure	It indicates the discharge pressure.
⑦		Circulating fluid flow rate	It indicates the fluid flow rate. This value is not measured by a flow meter. It should be used as a reference value (rough indication). It includes the flow rate in the bypass circuit.
⑧		Circulating fluid electric conductivity	It indicates the electric conductivity.*1
⑨	CH2	Operating condition display	Displays TEMP READY status. Displays the control status of the circulating fluid pressure.
⑩		Circulating fluid present temperature	Displays the circulating fluid temperature.
⑪		Circulating fluid set temperature	It indicates the set temperature. Press the numeric section to change the set temperature.
⑫		Circulating fluid discharge pressure	It indicates the discharge pressure.
⑬		Circulating fluid flow rate	It indicates the flow rate measured by a flow meter. It does not include the flow rate in the bypass circuit.
⑭	Circulating fluid electric conductivity	It indicates the electric conductivity.	
⑮	CH1	Independent pump operation	CH1 pump operates independently while the button is pressed.
⑯	CH2	Independent pump operation	CH2 pump operates independently while the button is pressed.
⑰	Common	Operation mode	To select a operation mode from the touch panel (LOCAL mode), contact input (DIO mode), serial communication (SERIAL mode), or Ethernet communication (Ethernet mode).
⑱		Operating condition display	It indicates the run and stop status of the product.
⑲		Run/Stop	To run/stop the product

*1 Displayed for Option D1 (CH1 With electric conductivity control)

Alarm

This unit displays 39 types of alarms.

Alarm No.	Indication	Explanation	Alarm No.	Indication	Explanation
AL01	CH1 Low Level FLT	CH1 abnormal low tank fluid level	AL24	CH2 Low Press.	CH2 circulating fluid discharge pressure drop
AL02	CH1 Low Level WRN	CH1 low tank fluid level	AL25	CH2 Low Press. Error	CH2 abnormal drop in circulating fluid discharge pressure
AL03	CH2 Low Level FLT	CH2 abnormal low tank fluid level	AL26	CH2 Flow Sensor	CH2 failure of circulating fluid discharge flow sensor
AL04	CH2 Low Level WRN	CH2 low tank fluid level	AL27	CH2 High Electric Conductivity	CH2 electric conductivity increase
AL06	Fan Inverter	Fan failure*1	AL28	CH1 High Electric Conductivity	CH2 electric conductivity increase (Option D1 only)
AL07	Internal Cooling Fan	Internal cooling fan failure*2	AL30	Digital Input 1	Contact input 1 signal detection
AL09	CH1 High Temp. FLT	CH1 abnormal rise of circulating fluid temperature	AL31	Digital Input 2	Contact input 2 signal detection
AL10	CH1 High Temp.	CH1 circulating fluid temperature rise	AL33	CH2 Low Flow FLT	CH2 abnormal drop in circulating fluid flow rate
AL11	CH1 Low Temp.	CH1 circulating fluid temperature drop	AL34	Communication	Communication error
AL12	CH1 TEMP READY Alarm	CH1 TEMP READY alarm	AL35	Ambient Temp.	Outside of the ambient temperature range
AL13	CH2 High Temp. FLT	CH2 abnormal rise in circulating fluid temperature	AL36	Maintenance	Maintenance alarm
AL14	CH2 High Temp.	CH2 circulating fluid temperature rise	AL37	Refrigeration Circuit	Compressor circuit failure
AL15	CH2 Low Temp.	CH2 circulating fluid temperature drop	AL38	Sensor	Sensor failure
AL16	CH2 TEMP READY Alarm	CH2 TEMP READY alarm	AL39	Controller	Controller failure
AL17	CH1 HX In High Temp. FLT	CH1 abnormal rise in heat exchanger inlet temperature	AL40	Compressor Inverter	Compressor inverter error
AL18	CH1 Press. Sensor	CH1 failure of circulating fluid discharge pressure sensor	AL41	Compressor Inverter Comm.	Compressor inverter communication error
AL19	CH1 High Press.	CH1 circulating fluid discharge pressure rise	AL42	CH1 Pump Inverter	CH1 pump inverter error
AL20	CH1 Low Press.	CH1 circulating fluid discharge pressure drop	AL43	CH1 Pump Inverter Comm.	CH1 pump inverter communication error
AL21	CH2 Press. Sensor	CH2 failure of circulating fluid discharge pressure sensor	AL44	CH2 Pump Inverter	CH2 pump inverter error
AL22	CH2 High Press. Error	CH2 abnormal rise in circulating fluid discharge pressure	AL45	CH2 Pump Inverter Comm.	CH2 pump inverter communication error
AL23	CH2 High Press.	CH2 circulating fluid discharge pressure rise			

*1 Does not occur on the product of water-cooled refrigeration type. *2 Does not occur on the product of air-cooled refrigeration type.

Communication Functions

Contact Input/Output

Contact Input/Output, Analog Output Communication Specifications

Item		Specifications	
Contact input signal 1, 2, 3	Insulation method	Photocoupler	
	Rated input voltage	24 VDC	
	Operating voltage range	21.6 to 26.4 VDC	
	Rated input current	5 mA TYP	
	Input impedance	4.7 kΩ	
Contact output signal 1, 2, 3, 4, 5, 6	Rated load voltage	48 VAC or less/30 VDC or less	
	Maximum load current	800 mA AC/DC or less*1	
	Minimum load current	5 VDC 10 mA	
	Output voltage range	0 to +10 V	
Analog output signal 1, 2	Maximum output current	10 mA	
	Output accuracy	±0.4% F.S. or less	
	Output voltage	24 VDC ±10% 200 mA MAX*1 (No inductive load)	

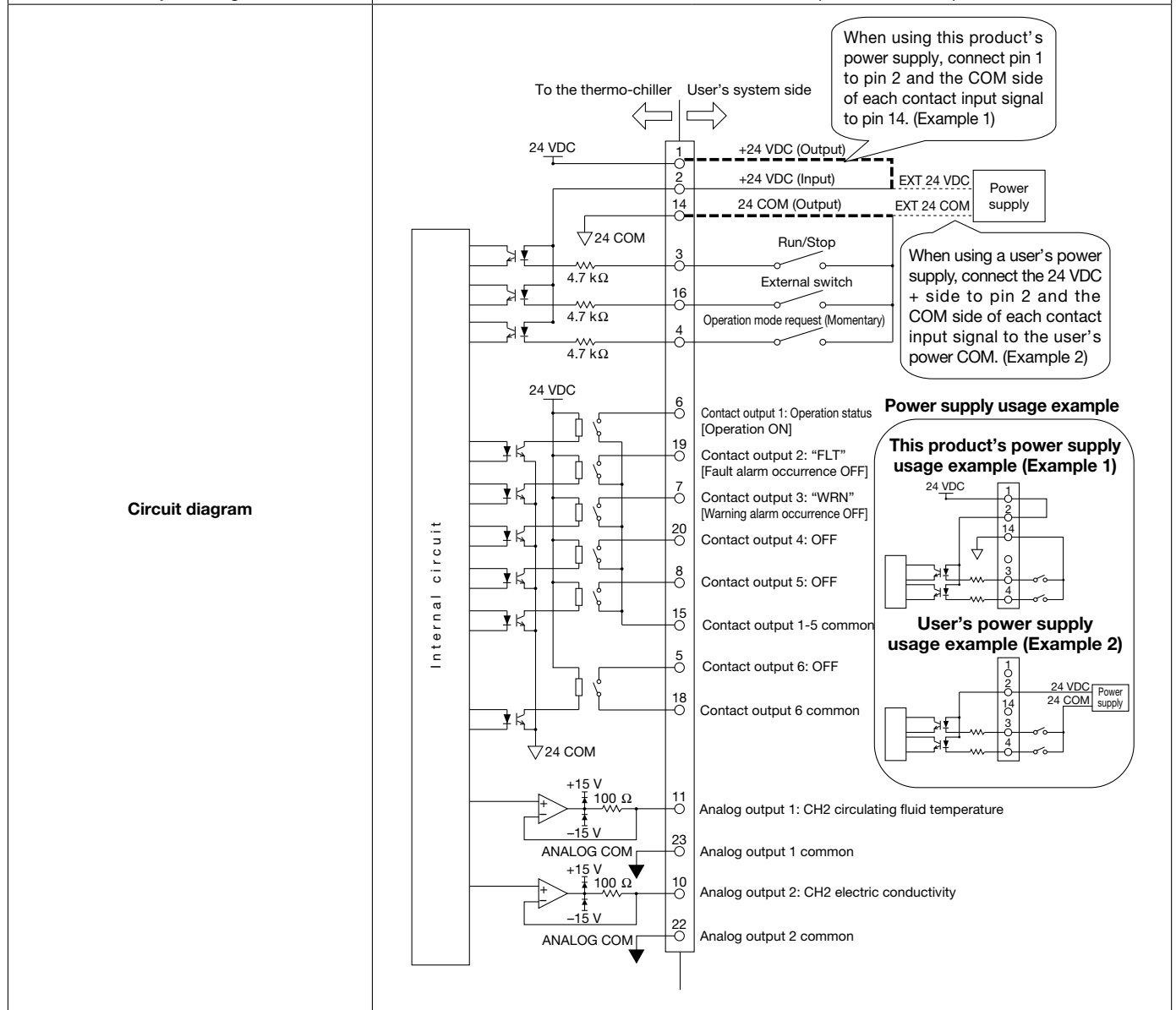

*1 Make sure that the total load current is 800 mA or less. When using the power supply of this product, make sure that the total load current is 200 mA or less.

Communication Functions

Contact Input/Output, Analog Output Pin Nos.

Pin no.	Application	Division	Default setting
1	24 VDC output	Output	—
2	24 VDC input	Input	—
3	Contact input signal 1	Input	Run/Stop*1
4	Contact input signal 3	Input	Operation mode request signal (fix)*2
5	Contact output signal 6	Output	OFF*1
6	Contact output signal 1	Output	Run status signal [N.O. type] (fix)*2
7	Contact output signal 3	Output	Operation continuation “WRN” alarm signal [N.C. type] (fix)*2
8	Contact output signal 5	Output	OFF*1
9	None	—	Cannot be connected*3
10	Analog output signal 2	Output	CH2 electric conductivity*1
11	Analog output signal 1	Output	CH2 circulating fluid temperature*1
12	None	—	Cannot be connected*3
13	None	—	Cannot be connected*3
14	24 COM output (Common of contact input signal)	Output	—
15	Common of contact output signal 1, 2, 3, 4, 5	Output	—
16	Contact input signal 2	Input	External switch signal*1
17	None	—	Cannot be connected*3
18	Common of contact output signal 6	Output	—
19	Contact output signal 2	Output	Operation stop “FLT” alarm signal [N.C. type] (fix)*2
20	Contact output signal 4	Output	OFF*1
21	None	—	Cannot be connected*3
22	Common of analog output signal 2	Output	—
23	Common of analog output signal 1	Output	—
24	None	—	Cannot be connected*3
25	None	—	Cannot be connected*3

*1 It is possible to change the setting.

*2 It is not possible to change the setting. (“N.O. type/N.C. type” can be changed.)

*3 Do not connect wiring.

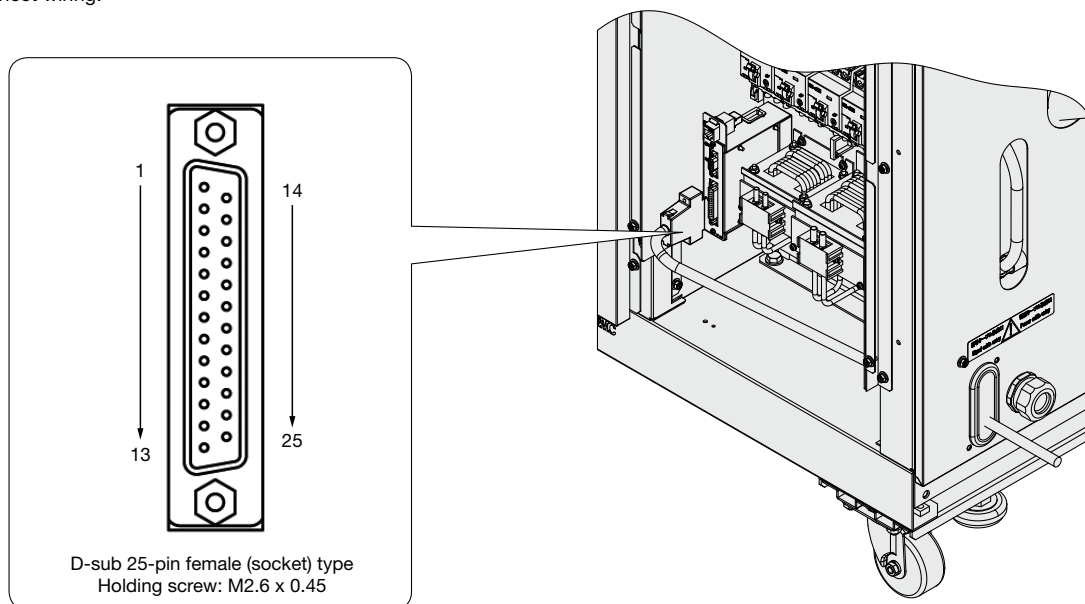

Communication Functions

Serial Communication

The following operations can be performed by the serial communication RS-232C/RS-485.

Writing

To run/stop the product
To change the set value of circulating fluid temperature

Readout

To readout the circulating fluid temperature, pressure, flow rate and electrical conductivity (CH1*¹)
To readout the circulating fluid temperature, pressure, flow rate and electrical conductivity (CH2)
To readout the status of respective parts of the product (e.g., operation status and content of alarm)

*1 For Option D1 (CH1 With electric conductivity control)

Wiring of Interface Cable for Serial Communication

Item	Specifications
Connector type	D-sub 9-pin female (socket) type
Configuration of connection	RS-485 One thermo-chiller for one host computer, or multiple thermo-chillers for one host computer. (31 thermo-chillers can be connected at maximum.)
Circuit diagram	<p style="text-align: center;">* Do not connect with other pins.</p>
Standards	RS-232C One thermo-chiller for one master
Circuit diagram	<p style="text-align: center;">* Do not connect with other pins.</p>

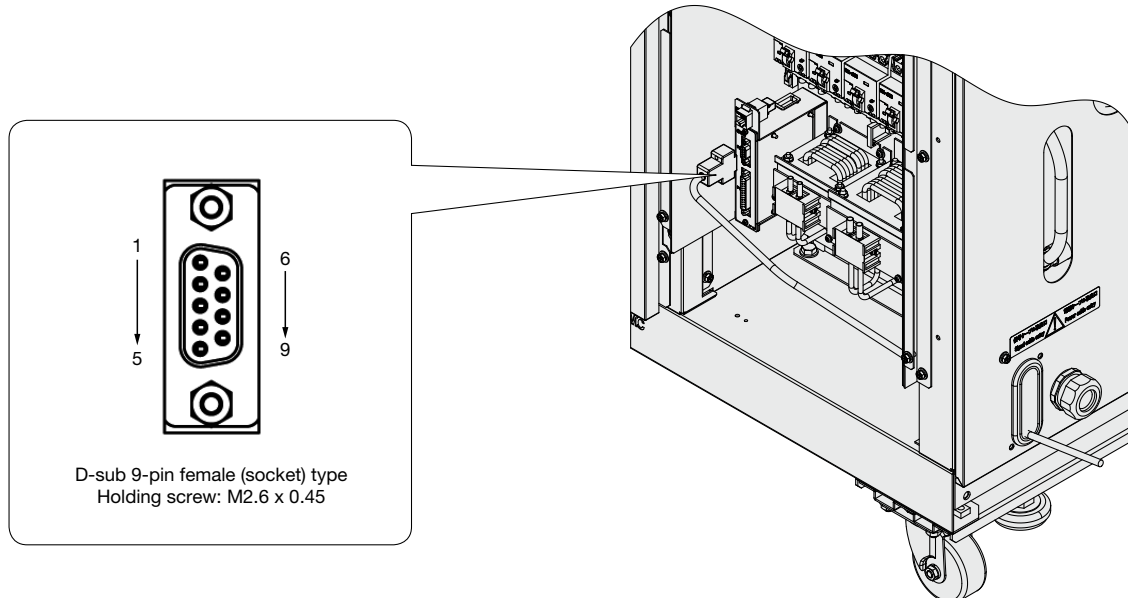

Communication Functions

Ethernet Modbus/TCP Communication

The following operations can be performed by the Ethernet Modbus/TCP communication.

Writing

To run/stop the product
To change the set value of circulating fluid temperature

Readout

To readout the circulating fluid temperature, pressure, flow rate and electrical conductivity (CH1*1)
To readout the circulating fluid temperature, pressure, flow rate and electrical conductivity (CH2)
To readout the status of respective parts of the product (e.g., operation status and content of alarm)
To readout the product model and serial number

*1 For Option D1 (CH1 With electric conductivity control)

Communication Cable Wiring for Ethernet Modbus/TCP Communication

Item	Specifications
Connector type	RJ45
Circuit diagram	<p>The user's equipment (client) and this product (server) can be connected via a hub. Up to 4 of the user's equipment can be connected at once.</p> <p>The diagram shows a central Hub with four ports. Two ports are connected to a box labeled 'User's equipment (Client)'. Two other ports are connected to a box labeled 'This product (Server)'. The Hub is represented by a rectangle with four small squares inside, and the connections are shown as lines leading to circles representing connection points on the client and server boxes.</p>

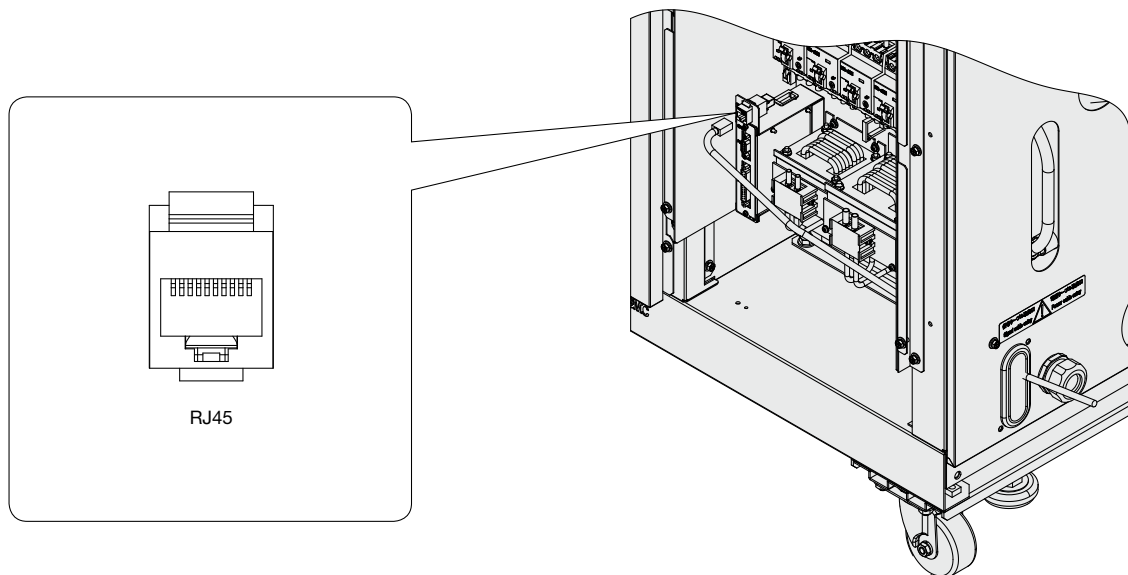

HRL Series Options

* Options have to be selected when ordering the thermo-chiller. It is not possible to add them after purchasing the unit.

D1 Option symbol

CH1, CH2 Electric Conductivity Control

HRL - - - D1

● CH1, CH2 Electric conductivity control

- For the standard model, only CH2 has electric conductivity control. However, if option “D1” is selected, CH1 also has electric conductivity control.
- Contact material of the circulating fluid circuit is made from non-copper materials.

* When the CH1, CH2 electric conductivity control option is selected, the weight increases by 1 kg.

T2 Option symbol

CH2 High-Pressure Pump Mounted

HRL - - 40 - T2

● CH2 High-pressure pump mounted

Possible to choose a high-pressure pump in accordance with user’s piping resistance
Total cooling capacity of CH1 and CH2 will decrease by heat generated in the pump.

Applicable model		HRL <input type="checkbox"/> - A/W <input type="checkbox"/> - 40 - T2	
		CH1	CH2
Pump	Rated flow rate (Outlet) L/min	Same as standard product	20 (0.45 MPa)
	Maximum flow rate L/min	Same as standard product	30
	Maximum pump head m	Same as standard product	Same as standard product
Minimum operating flow rate L/min		Same as standard product	5
Tank capacity L		Same as standard product	Same as standard product
Cooling capacity W		It differs from the standard cooling capacity. Refer to the table below for the details.	

* When the CH2 high-pressure pump mounted option is selected, the weight increases by 1 kg.

Pump Capacity

HRL - A/W - 40 - T2

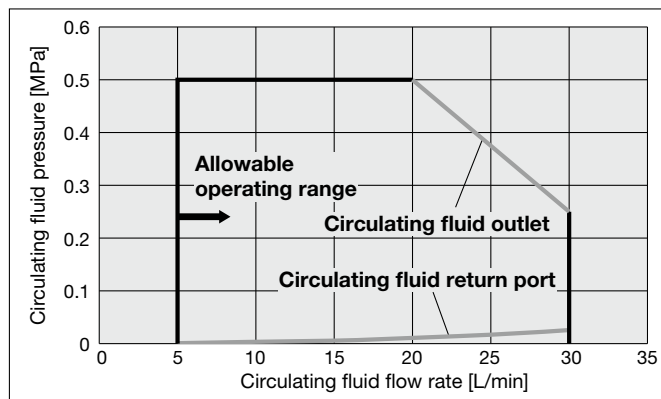

T2

Option symbol

CH2 High-Pressure Pump Mounted

Cooling Capacity

HRL100-A□-40-T2 (CH1)*1

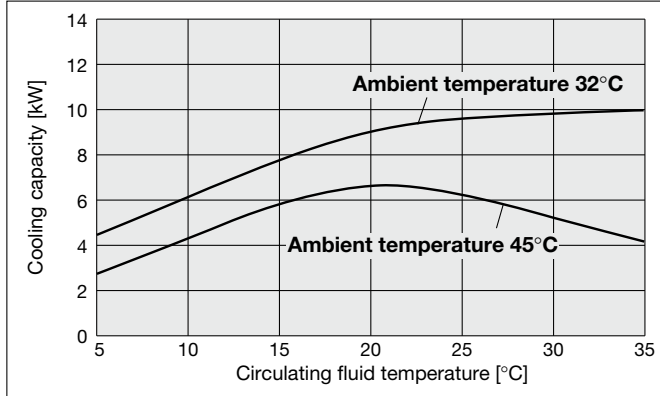

HRL200-A□-40-T2 (CH1)*1

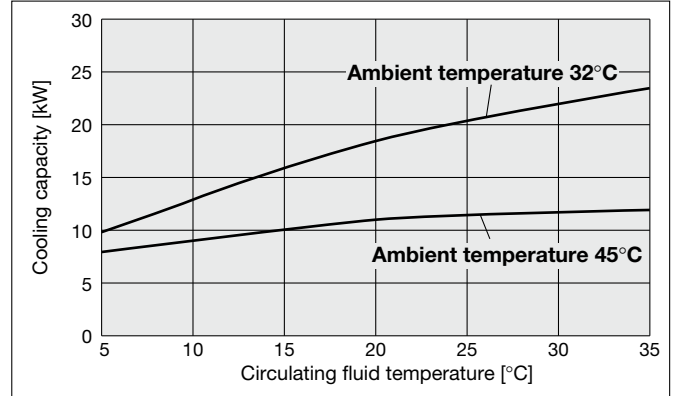

HRL300-A□-40-T2 (CH1)*1

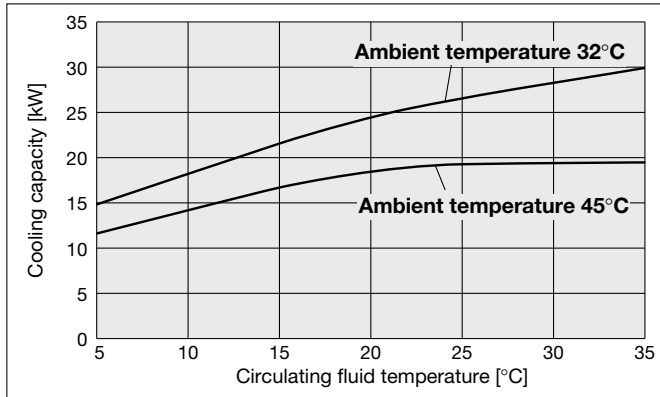

HRL□-A/W□-40-T2 (CH2)*2

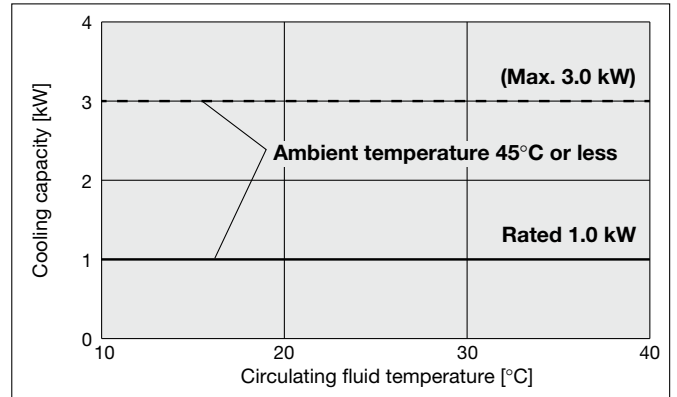

HRL100-W□-40-T2 (CH1)*1

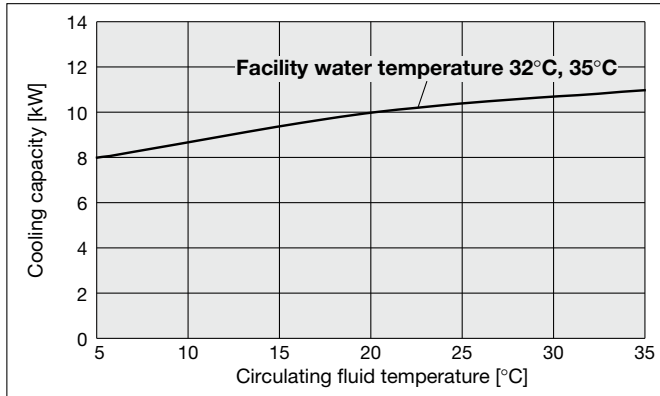

HRL200-W□-40-T2 (CH1)*1

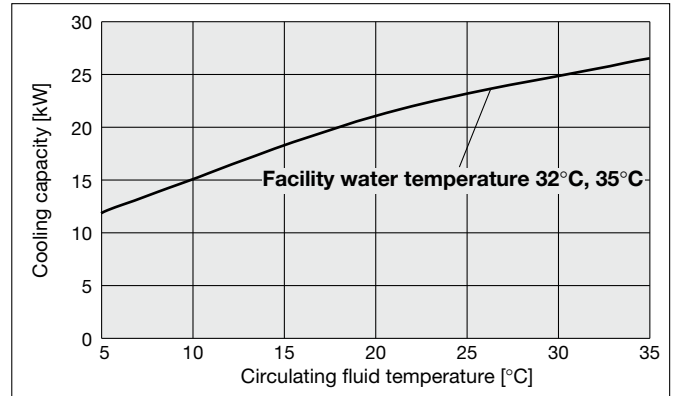

HRL400-A□-40-T2 (CH1)*1

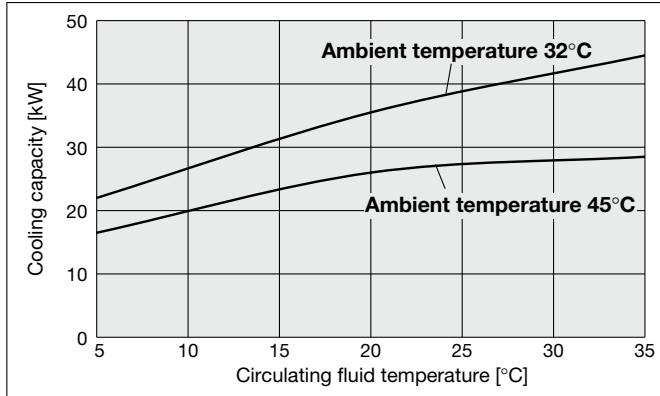

*1 This is the cooling capacity of the CH1 side when 1 kW heat load is applied to the CH2 side.

*2 Up to 3.0 kW. However, when 3.0 kW heat load is applied, the cooling capacity of CH1 will decrease by 2.0 kW.

HRL Series

T3

Option symbol

CH2 High-Pressure Pump Mounted

HRL - - 40 - T3

● CH2 High-pressure pump mounted

Possible to choose a high-pressure pump in accordance with user's piping resistance
Total cooling capacity of CH1 and CH2 will decrease by heat generated in the pump.

- The CH2 pump used for option T3 uses a mechanical seal.
- We will inform you of the inspection time in the maintenance notice. Please contact to service center to ask for maintenance of the pump and mechanical seal.

* The HRL100/200 cannot be selected.

Applicable model		HRL300-A□-40-T3		HRL400-A□-40-T3	
		CH1	CH2	CH1	CH2
Pump	Rated flow rate (Outlet) L/min	Same as standard product	38 (0.45 MPa)	Same as standard product	38 (0.45 MPa)
	Maximum flow rate L/min	Same as standard product	60	Same as standard product	60
	Maximum pump head m	Same as standard product	49	Same as standard product	49
Minimum operating flow rate L/min		Same as standard product	10	Same as standard product	10
Tank capacity L		Same as standard product	12	Same as standard product	Same as standard product
Cooling capacity W		There is a cooling capacity decrease of approx. 2 kW compared with the standard model. Refer to the table below for the details.			

* When the CH2 high-pressure pump mounted option is selected, the weight increases by 18 kg for the HRL300 and 15 kg for the HRL400.

Port Layout (CH2)

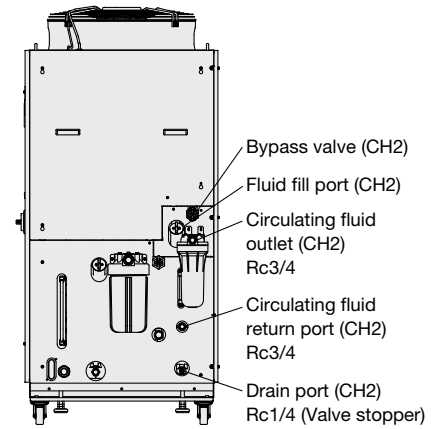

* CH1 port layout unchanged.

Pump Capacity

HRL300-A□-40-T3 (CH2)

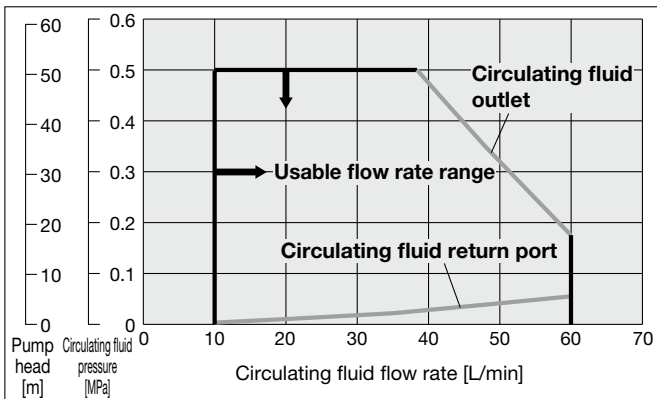

Cooling Capacity

HRL300-A□-40-T3 (CH1)*1

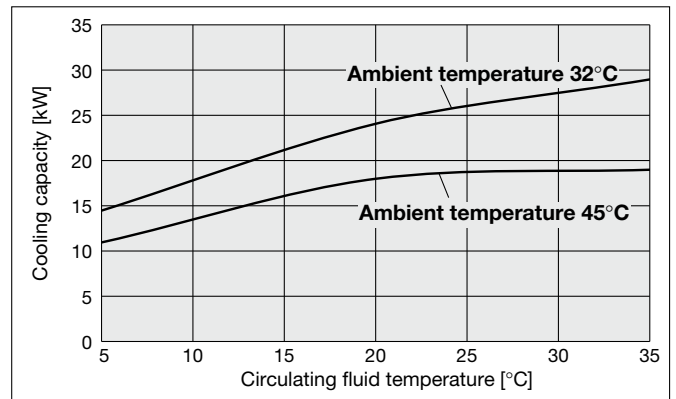

Cooling Capacity

HRL300/400-A□-40-T3 (CH2)*2

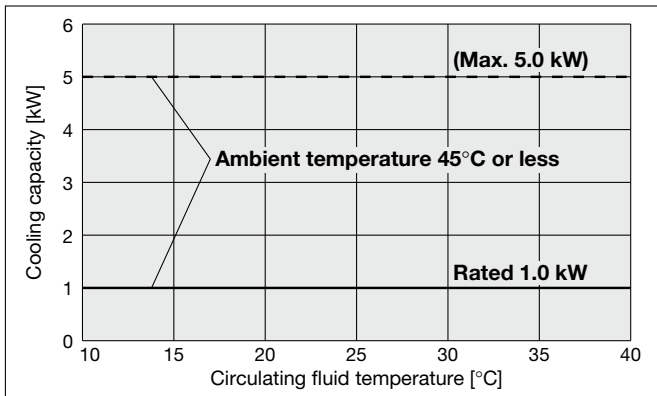

HRL400-A□-40-T3 (CH1)*1

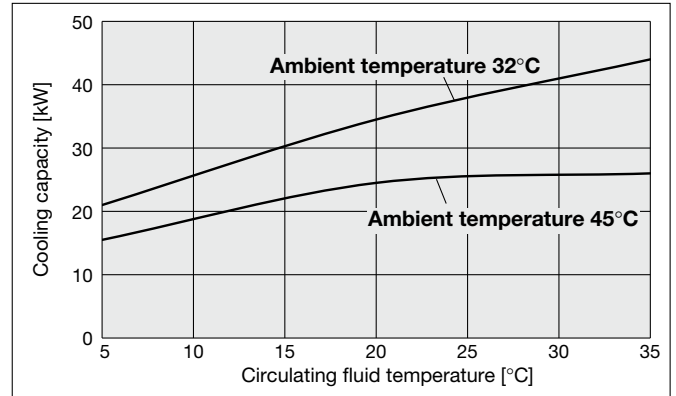

*1 This is the cooling capacity of the CH1 side when 1 kW heat load is applied to the CH2 side.

*2 Up to 5.0 kW. However, when 5.0 kW heat load is applied, the cooling capacity of CH1 will decrease by 4.0 kW.

HRL Series

Optional Accessories

Consumables List

Part no.	Description	Qty.	Note
HRS-S0213	Dustproof filter (Lower)	1	For HRL200-A: 2 pcs. are used per unit.
HRS-S0214	Dustproof filter (Upper)	1	For HRL100/200-A: 2 pcs. are used per unit.
HRS-S0185	Dustproof filter	1	For HRL300-A: 4 pcs. are used per unit.
HRL-S0153	Dustproof filter	1	For HRL400-A: 4 pcs. are used per unit.
HRS-PF006	Particle filter element	1	Common to each model: For CH1
EJ202S-005X11	Particle filter element	1	Common to each model: For CH2 (Except option-T3)
EJ302S-005X11	Particle filter element	1	For option-T3: For CH2
HRR-DF001	DI filter replacement cartridge	1	Common to each model: For CH2
HRR-DF002	DI filter replacement cartridge	1	Common to each model: For CH1 Option D1 only

Cooling Capacity Calculation

Required Cooling Capacity Calculation

Example 1: When the heat generation amount in the user's equipment is known.

The heat generation amount can be determined based on the power consumption or output of the heat generating area — i.e. the area requiring cooling — within the user's equipment.*1

① Derive the heat generation amount from the power consumption.

Power consumption **P**: 20 [kW]

$$Q = P = 20 \text{ [kW]}$$

Cooling capacity = Considering a safety factor of 20%, $20 \text{ [kW]} \times 1.2 = 24 \text{ [kW]}$

② Derive the heat generation amount from the power supply output.

Power supply output **VI**: 20 [kVA]

$$Q = P = V \times I \times \text{Power factor}$$

In this example, using a power factor of 0.85:

$$= 20 \text{ [kVA]} \times 0.85 = 17 \text{ [kW]}$$

Cooling capacity = Considering a safety factor of 20%,

$$17 \text{ [kW]} \times 1.2 = 20.4 \text{ [kW]}$$

③ Derive the heat generation amount from the output.

Output (shaft power, etc.) **W**: 13 [kW]

$$Q = P = \frac{W}{\text{Efficiency}}$$

In this example, using an efficiency of 0.7:

$$= \frac{13}{0.7} = 18.6 \text{ [kW]}$$

Cooling capacity = Considering a safety factor of 20%,

$$18.6 \text{ [kW]} \times 1.2 = 22.3 \text{ [kW]}$$

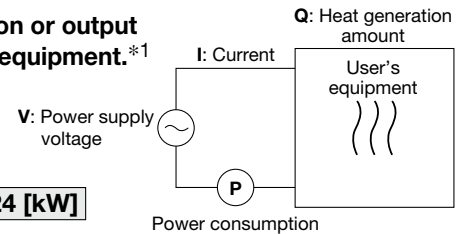

*1 The examples above calculate the heat generation amount based on the power consumption. The actual heat generation amount may differ due to the structure of the user's equipment. Be sure to check it carefully.

④ Calculate based on the laser output.

Laser output power **6 [kW]**, conversion efficiency **30%**

The oscillator's power consumption is,

$$6 \text{ [kW]} \div 0.3 = 20 \text{ [kW]}$$

The cooling capacity required for the oscillator is,

$$20 \text{ [kW]} - 6 \text{ [kW]} = 14 \text{ [kW]}$$

Considering a safety factor of 20%,

$$14 \text{ [kW]} \times 1.2 = 16.8 \text{ [kW]}$$

Example 2: When the heat generation amount in the user's equipment is not known.

Obtain the temperature difference between inlet and outlet by circulating the circulating fluid inside the user's equipment.

Heat generation amount by user's equipment **Q** : Unknown [W] (J/s)
 Circulating fluid : Tap water*1
 Circulating fluid mass flow rate **qm** : (= $\rho \times qv \div 60$) [kg/s]
 Circulating fluid density ρ : 1 [kg/L]
 Circulating fluid (volume) flow rate **qv** : 70 [L/min]
 Circulating fluid specific heat **C** : 4.186×10^3 [J/(kg·K)]
 Circulating fluid outlet temperature **T1** : 293 [K] (20 [°C])
 Circulating fluid return temperature **T2** : 297 [K] (24 [°C])
 Circulating fluid temperature difference ΔT : 4 [K] (= $T_2 - T_1$)
 Conversion factor: minutes to seconds (SI units): 60 [s/min]

*1 Refer to page 426 for the typical physical property value of tap water or other circulating fluids.

$$Q = qm \times C \times (T_2 - T_1)$$

$$= \frac{\rho \times qv \times C \times \Delta T}{60} = \frac{1 \times 70 \times 4.186 \times 10^3 \times 4.0}{60}$$

$$= 19535 \text{ [J/s]} \approx 19535 \text{ [W]} = 19.5 \text{ [kW]}$$

Cooling capacity = Considering a safety factor of 20%,

$$19.5 \text{ [kW]} \times 1.2 = 23.4 \text{ [kW]}$$

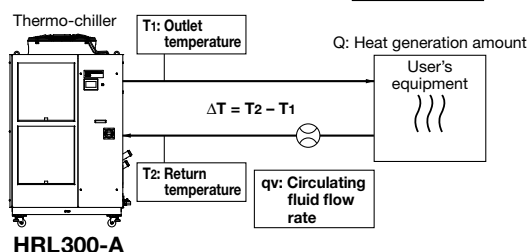

Example of conventional units (Reference)

Heat generation amount by user's equipment **Q**: Unknown [cal/h] → [W]
 Circulating fluid : Tap water*1
 Circulating fluid weight flow rate **qm** : (= $\rho \times qv \times 60$) [kgf/h]
 Circulating fluid weight volume ratio γ : 1 [kgf/L]
 Circulating fluid (volume) flow rate **qv** : 70 [L/min]
 Circulating fluid specific heat **C** : 1.0×10^3 [cal/(kgf·°C)]
 Circulating fluid outlet temperature **T1**: 20 [°C]
 Circulating fluid return temperature **T2**: 24 [°C]
 Circulating fluid temperature difference ΔT : 4 [°C] (= $T_2 - T_1$)
 Conversion factor: hours to minutes : 60 [min/h]
 Conversion factor: kcal/h to kW : 860 [(cal/h)/W]

$$Q = \frac{qm \times C \times (T_2 - T_1)}{860}$$

$$= \frac{\gamma \times qv \times 60 \times C \times \Delta T}{860}$$

$$= \frac{1 \times 70 \times 60 \times 1.0 \times 10^3 \times 4.0}{860}$$

$$= \frac{16800000 \text{ [cal/h]}}{860}$$

$$\approx 19534 \text{ [W]} = 19.5 \text{ [kW]}$$

Cooling capacity = Considering a safety factor of 20%,

$$19.5 \text{ [kW]} \times 1.2 = 23.4 \text{ [kW]}$$

Required Cooling Capacity Calculation

Example 3: When there is no heat generation, and when cooling the object below a certain temperature and period of time.

Heat quantity by cooled substance (per unit time) **Q** : Unknown [W] [(J/s)]
 Cooled substance : Water
 Cooled substance mass **m** : (= $\rho \times V$) [kg]
 Cooled substance density ρ : 1 [kg/L]
 Cooled substance total volume **V** : 250 [L]
 Cooled substance specific heat **C** : 4.186×10^3 [J/(kg·K)]
 Cooled substance temperature when cooling begins **To** : 305 [K] (32 [°C])
 Cooled substance temperature after t hour **Tt** : 293 [K] (20 [°C])
 Cooling temperature difference ΔT : 12 [K] (= $T_o - T_t$)
 Cooling time Δt : 900 [s] (= 15 [min])

* Refer to the following for the typical physical property values by circulating fluid.

$$Q = \frac{m \times C \times (T_o - T_t)}{\Delta t} = \frac{\rho \times V \times C \times \Delta T}{\Delta t}$$

$$= \frac{1 \times 250 \times 4.186 \times 10^3 \times 12}{900} = 13953 \text{ [J/s]} \approx 14.0 \text{ [kW]}$$

Cooling capacity = Considering a safety factor of 20%,

$$14.0 \text{ [kW]} \times 1.2 = \mathbf{16.8 \text{ [kW]}}$$

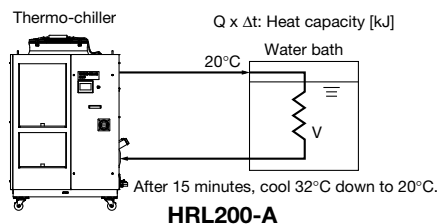

Example of conventional units (Reference)

Heat quantity by cooled substance (per unit time) **Q** : Unknown [cal/h] → [W]
 Cooled substance : Water
 Cooled substance weight **m** : (= $\rho \times V$) [kgf]
 Cooled substance weight volume ratio γ : 1 [kgf/L]
 Cooled substance total volume **V** : 250 [L]
 Cooled substance specific heat **C** : 1.0×10^3 [cal/(kgf·°C)]
 Cooled substance temperature when cooling begins **To** : 32 [°C]
 Cooled substance temperature after t hour **Tt** : 20 [°C]
 Cooling temperature difference ΔT : 12 [°C] (= $T_o - T_t$)
 Cooling time Δt : 15 [min]
 Conversion factor: hours to minutes : 60 [min/h]
 Conversion factor: kcal/h to kW : 860 [(cal/h)/W]

$$Q = \frac{m \times C \times (T_o - T_t)}{\Delta t \times 860} = \frac{\gamma \times V \times 60 \times C \times \Delta T}{\Delta t \times 860}$$

$$= \frac{1 \times 250 \times 60 \times 1.0 \times 10^3 \times 12}{15 \times 860}$$

$$\approx 13953 \text{ [W]} = 14.0 \text{ [kW]}$$

Cooling capacity = Considering a safety factor of 20%,

$$14.0 \text{ [kW]} \times 1.2 = \mathbf{16.8 \text{ [kW]}}$$

* This is the calculated value by changing the fluid temperature only. Thus, it varies substantially depending on the water bath or piping shape.

Precautions on Cooling Capacity Calculation

1. Heating capacity

When the circulating fluid temperature is set above room temperature, it needs to be heated by the thermo-chiller. The heating capacity depends on the circulating fluid temperature. Consider the radiation rate and heat capacity of the user's equipment and check beforehand if the required heating capacity is provided.

2. Pump capacity

<Circulating fluid flow rate>

Circulating fluid flow rate varies depending on the circulating fluid discharge pressure. Consider the installation height difference between the thermo-chiller and the user's equipment, and the piping resistance such as circulating fluid pipings, or piping size, or piping curves in the machine. Check beforehand if the required flow is achieved, using the pump capacity curves.

<Circulating fluid discharge pressure>

Circulating fluid discharge pressure has the possibility to increase up to the maximum pressure in the pump capacity curves. Check beforehand if the circulating fluid pipings or circulating fluid circuit of the user's equipment are fully durable against this pressure.

Circulating Fluid Typical Physical Property Values

1. This catalog uses the following values for density and specific heat in calculating the required cooling capacity.

Density ρ : 1 [kg/L] (or, using conventional units, weight volume ratio $\gamma = 1$ [kgf/L])

Specific heat **C**: 4.19×10^3 [J/(kg·K)] (or, using conventional units, 1×10^3 [cal/(kgf·°C)])

2. Values for density and specific heat change slightly according to temperature shown below. Use this as a reference.

Water

Physical property value Temperature	Density ρ [kg/L]	Specific heat C [J/(kg·K)]	Conventional units	
			Weight volume ratio γ [kgf/L]	Specific heat C [cal/(kgf·°C)]
5°C	1.00	4.2×10^3	1.00	1×10^3
10°C	1.00	4.19×10^3	1.00	1×10^3
15°C	1.00	4.19×10^3	1.00	1×10^3
20°C	1.00	4.18×10^3	1.00	1×10^3
25°C	1.00	4.18×10^3	1.00	1×10^3
30°C	1.00	4.18×10^3	1.00	1×10^3
35°C	0.99	4.18×10^3	0.99	1×10^3
40°C	0.99	4.18×10^3	0.99	1×10^3



HRL Series

Specific Product Precautions 1

Be sure to read this before handling the products. Refer to the back cover for safety instructions. For temperature control equipment precautions, refer to the “Handling Precautions for SMC Products” and the “Operation Manual” on the SMC website: <https://www.smworld.com>

Design

Warning

1. This catalog shows the specifications of a single unit.

- 1) Check the specifications of the single unit (contents of this catalog) and thoroughly consider the adaptability between the user’s system and this unit.
- 2) Although a protection circuit as a single unit is installed, prepare a drain pan, water leakage sensor, discharge air facility, and emergency stop equipment, depending on the user’s operating conditions. Also, the user is requested to carry out a safety design for the whole system.

2. When attempting to cool areas that are open to the atmosphere (tanks, pipes), plan your piping system accordingly.

When cooling open-air external tanks, arrange the piping so that there are coil pipes for cooling inside the tanks and to carry back the entire flow volume of circulating fluid that is released.

3. Use non-corrosive material for circulating fluid contact parts.

Using corrosive materials such as aluminum or iron for fluid contact parts such as piping may cause clogging or leakage in the circulating fluid circuit. Provide protection against corrosion when you use the product.

Selection

Warning

Model selection

When selecting a thermo-chiller model, the amount of heat generation from the user’s equipment must be known. Obtain this value, referring to “Cooling Capacity Calculation” on pages 37 and 38 before selecting a model.

Handling

Warning

Thoroughly read the operation manual.

Read the operation manual completely before operation, and keep this manual where it can be referred to as necessary.

Operating Environment/Storage Environment

Warning

1. Do not use in the following environment as it will lead to a breakdown.

- 1) In locations where water vapor, salt water, and oil may splash on the product
- 2) In locations where there are dust and particles
- 3) In locations where corrosive gases, organic solvents, chemical fluids, or flammable gases are present (This product is not explosion proof.)
- 4) In locations where the ambient temperature exceeds the limits as mentioned below
 - During transportation/storage: -15°C to 50°C (But as long as water or circulating fluid are not left inside the pipings)
 - During operation (Air-cooled type): 2°C to 45°C
- 5) In locations where condensation may occur
- 6) In locations which receive direct sunlight or radiated heat
- 7) In locations where there is a heat source nearby and the ventilation is poor
- 8) In locations where temperature substantially changes
- 9) In locations where strong magnetic noise occurs (In locations where strong electric fields, strong magnetic fields, and surge voltage occur)
- 10) In locations where static electricity occurs, or conditions which make the product discharge static electricity
- 11) In locations where high frequency occurs
- 12) In locations where damage is likely to occur due to lightning
- 13) In locations at an altitude of 3000 m or higher (Except during storage and transportation)

* For altitudes of 1000 m or higher

Because of lower air density, the heat radiation efficiencies of the devices in the product will be lower in the location at an altitude of 1000 m or higher. Therefore, the maximum ambient temperature to use and the cooling capacity will lower according to the descriptions in the table below.

Select the thermo-chiller considering the descriptions.

- ① Upper limit of ambient temperature: Use the product in ambient temperature of the described value or lower at each altitude.
- ② Cooling capacity coefficient: The product’s cooling capacity will lower to one that multiplied by the described value at each altitude.

Altitude [m]	① Upper limit of ambient temperature [°C]	② Cooling capacity coefficient
Less than 1000 m	45	1.00
Less than 1500 m	42	0.85
Less than 2000 m	38	0.80
Less than 2500 m	35	0.75
Less than 3000 m	32	0.70

- 14) In locations where strong impacts or vibrations occur
- 15) In locations where a massive force strong enough to deform the product is applied or the weight from a heavy object is applied
- 16) In locations where there is not sufficient space for maintenance
- 17) Insects or plants may enter the unit

2. The product is not designed for clean room usage. It generates particles internally.

3. The product is not dust-proof.

If used in an environment with dust, it may accumulate inside the product and cause not only a malfunction but also a fire hazard.



HRL Series Specific Product Precautions 2

Be sure to read this before handling the products. Refer to the back cover for safety instructions. For temperature control equipment precautions, refer to the "Handling Precautions for SMC Products" and the "Operation Manual" on the SMC website: <https://www.smcworld.com>

Transportation/Carriage/Movement

Warning

1. This product will require an acceptance with the product not unloaded from the truck, and the user will need to unload the product by himself. Prepare a forklift.

The product will be delivered in the packaging shown below.

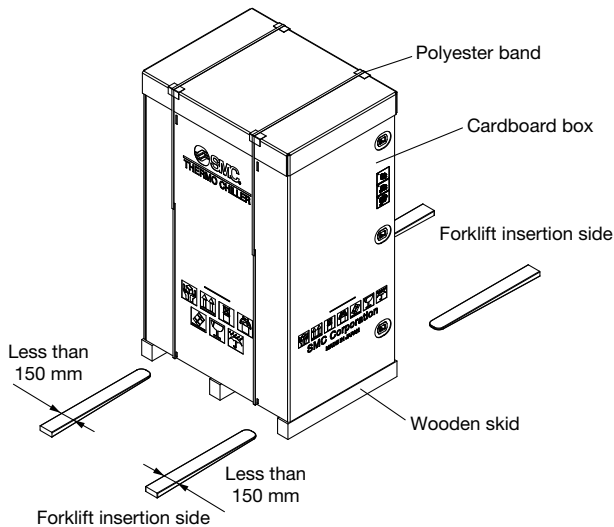

Weights and Dimensions When Packaged

Model	Weight [kg]	Dimensions [mm]
HRL100-A□-20	301	Height 2020 x Width 1200 x Depth 893
HRL200-A□-20	330	
HRL300-A□-20	418	Height 2120 x Width 1400 x Depth 1060
HRL100-A□-40	319	Height 2020 x Width 1200 x Depth 893
HRL200-A□-40	339	
HRL300-A□-40	433	Height 2120 x Width 1400 x Depth 1060
HRL400-A□-40	475	Height 2020 x Width 1650 x Depth 1060
HRL100-W□-20	314	Height 2020 x Width 1200 x Depth 893
HRL200-W□-20		
HRL100-W□-40	329	
HRL200-W□-40		

* For models with an option, the weight increases as shown below.

Option symbol	Description	Product series	Additional weight
F	G (with Rc-G conversion fitting set)	All series	+1 kg
N	NPT (with Rc-NPT conversion fitting set)	All series	+1 kg
-D1	CH1, CH2 Electric conductivity control	All series	+1 kg
-T2	CH2 High-pressure pump mounted	HRL200	+1 kg
-T3	CH2 High-pressure pump mounted	HRL300	+18 kg
		HRL400	+15 kg

2. Transporting with forklift

- 1) A licensed driver should drive the forklift.
- 2) The proper place to insert the tines of the forklift differs depending on the model of cooler. Check the insert position, and be sure to drive the fork in far enough for it to come out the other side.
- 3) Be careful not to bump the fork to the cover panel or piping ports.

Transportation/Carriage/Movement

Warning

3. Hanging transportation

- 1) Crane manipulation and slinging work should be done by an eligible person.
- 2) Do not grip the piping on the right side or the handles of the panel.
- 3) When hanging by the eye bolts, be sure to use a 4-point hanging method. For the hanging angle, use caution regarding the position of the center of gravity and hold it within 60°.

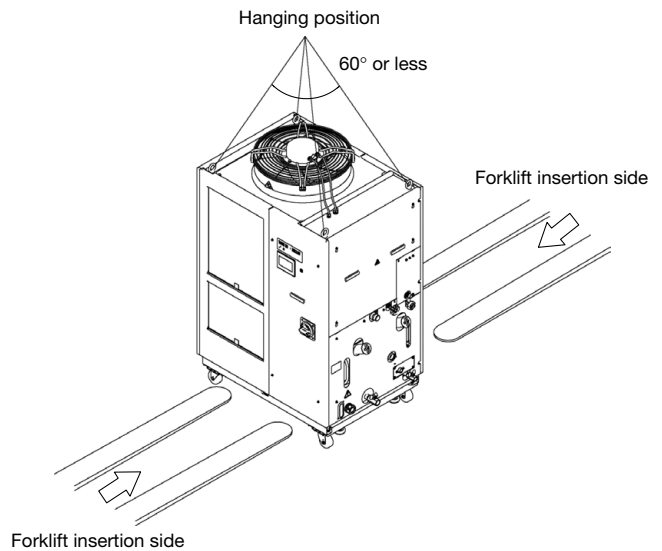

4. Transporting with casters

- 1) This product is heavy and should be moved by at least two people.
- 2) Do not grip the piping port on the right side or the handles of the panel.
- 3) When transporting using a forklift, be sure not to let it hit the casters or adjusters, and drive the fork all the way through until it comes out the other side.
- 4) Do not get across steps with casters.

Caution

If this product is to be transported after delivery, please use the original packaging the product was delivered in. If other packaging is to be used, carefully package the product so as to prevent the product from incurring any damage during transport.

Mounting/Installation

Warning

Do not place heavy objects on top of this product, or step on it.

The external panel can be deformed and danger can result.

Caution

1. Install on a rigid floor which can withstand this product's weight.
2. Secure with bolts, anchor bolts, etc.



HRL Series Specific Product Precautions 3

Be sure to read this before handling the products. Refer to the back cover for safety instructions. For temperature control equipment precautions, refer to the “Handling Precautions for SMC Products” and the “Operation Manual” on the SMC website: <https://www.smcworld.com>

Mounting/Installation

⚠ Caution

3. Refer to the operation manual for this product, and secure an installation space that is necessary for the maintenance and ventilation.

<Air-cooled refrigeration>

1. The air-cooled type product exhausts heat using the fan that is mounted to the product. If the product is operated with insufficient ventilation, ambient temperature may exceed 45°C, and this will affect the performance and life of the product. To prevent this ensure that suitable ventilation is available (see below).
2. For installation indoors, ventilation ports and a ventilation fan should be equipped as needed.

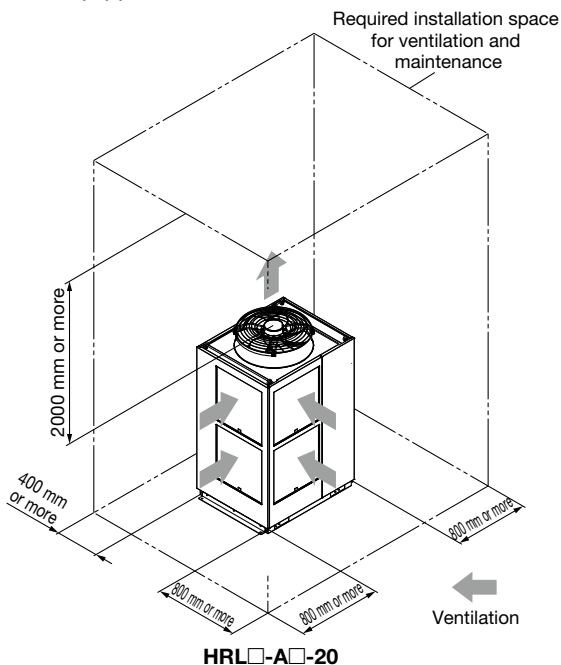

3. If it is impossible to exhaust heat from the installation area indoors, or when the installation area is conditioned, provide a duct for heat exhaustion to the air outlet port of this product for ventilation. Do not mount the inlet of the duct (flange) directly to the air vent of the product, and keep a space larger than the diameter of the duct. Additionally, consider the resistance of the duct when making the air vent port for the duct.

<Heat radiation amount/Required ventilation rate>

Model	Heat radiation amount [kW]	Required ventilation rate [m ³ /min]	
		Differential temp. of 3°C between inside and outside of installation area	Differential temp. of 6°C between inside and outside of installation area
HRL100-A□-□	Approx. 18	305	155
HRL200-A□-□	Approx. 35	590	295
HRL300-A□-□	Approx. 45	760	380
HRL400-A□-40	Approx. 55	930	465

Piping

⚠ Caution

1. Regarding the circulating fluid piping, consider carefully the suitability for operating pressure, temperature and circulating fluid.

If the operating performance is not sufficient, the pipings may burst during operation. Also, the use of corrosive materials such as aluminum or iron for fluid contact parts, such as piping, may not only lead to clogging or leakage in the circulating fluid circuit but also refrigerant leakage and other unexpected problems. Provide protection against corrosion when you use the product.

2. Select the piping port size which can exceed the rated flow.

For the rated flow, refer to the pump capacity table.

3. When tightening at the drain port of this product, use a pipe wrench to clamp the connection ports.

4. For the circulating fluid piping connection, install a drain pan and wastewater collection pit just in case the circulating fluid may leak.

5. This product series are constant-temperature fluid circulating machines with built-in tanks.

Do not install equipment on your system side such as pumps that forcibly return the circulating fluid to the unit. Also, if you attach an external tank that is open to the air, it may become impossible to circulate the circulating fluid. Proceed with caution.



HRL Series Specific Product Precautions 4

Be sure to read this before handling the products. Refer to the back cover for safety instructions. For temperature control equipment precautions, refer to the "Handling Precautions for SMC Products" and the "Operation Manual" on the SMC website: <https://www.smcworld.com>

Electrical Wiring

Warning

Grounding should never be connected to a water line, gas line or lightning rod.

Caution

1. Power supply and communication cables should be prepared by user.
2. Provide a stable power supply which is not affected by surge or distortion.

If the voltage increase ratio (dV/dt) at the zero cross should exceed $40 \text{ V}/200 \mu\text{sec.}$, it may result in malfunction.

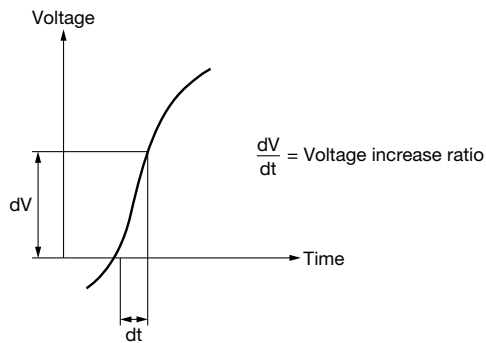

3. This product is installed with a breaker with the following operating characteristics.

For the user's equipment (on the upstream side), use a breaker whose operating time is equal to or longer than the breaker of this product. If a breaker with shorter operating time is connected, the user's equipment could be cut off due to the inrush current of the motor of this product.

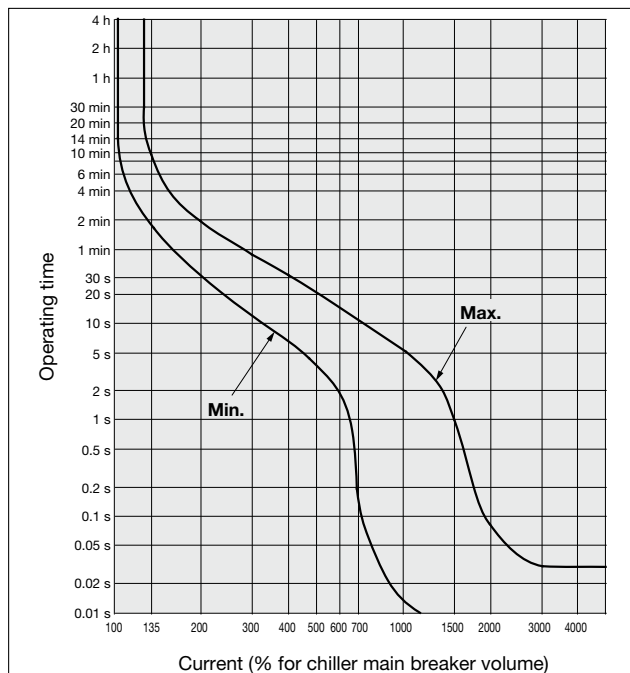

Circulating Fluid

Caution

1. Avoid oil or other foreign matter entering the circulating fluid.
2. When water is used as a circulating fluid, SMC recommends the water quality shown in the following table as reference.

- Including water used for dilution of ethylene glycol aqueous solutions.
- In most areas, tap water can be used. However, if the tap water in the area is hard, there is a possibility of failure or performance decline due to limescale build-up. To soften the water and avoid problems, consider using water hardness filters.

Tap Water (as a Circulating Fluid) Quality Standards

The Japan Refrigeration and Air Conditioning Industry Association
JRA GL-02-1994 "Cooling water system - Circulation type - Make-up water"

	Item	Unit	Standard value	Influence	
				Corrosion	Scale generation
Standard item	pH (at 25°C)	—	6.0 to 8.0	○	○
	Electric conductivity (25°C)	[$\mu\text{S}/\text{cm}$]	100^{*1} to 300^{*1}	○	○
	Chloride ion (Cl^-)	[mg/L]	50 or less	○	
	Sulfuric acid ion (SO_4^{2-})	[mg/L]	50 or less	○	
	Acid consumption amount (at pH4.8)	[mg/L]	50 or less		○
	Total hardness	[mg/L]	70 or less		○
Reference item	Calcium hardness (CaCO_3)	[mg/L]	50 or less		○
	Ionic state silica (SiO_2)	[mg/L]	30 or less		○
	Iron (Fe)	[mg/L]	0.3 or less	○	○
	Copper (Cu)	[mg/L]	0.1 or less	○	
	Sulfide ion (S_2^-)	[mg/L]	Should not be detected.	○	
	Ammonium ion (NH_4^+)	[mg/L]	0.1 or less	○	
	Residual chlorine (Cl)	[mg/L]	0.3 or less	○	
	Free carbon (CO_2)	[mg/L]	4.0 or less	○	

*1 In the case of [$\text{M}\Omega\text{-cm}$], it will be 0.003 to 0.01.

○: Factors that have an effect on corrosion or scale generation.

• Even if the water quality standards are met, complete prevention of corrosion is not guaranteed.

3. When deionized water is used, the electric conductivity should be $1 \mu\text{S}/\text{cm}$ or higher (Electric resistivity: $1 \text{ M}\Omega\text{-cm}$ or lower).

Operation

Warning

1. Confirmation before operation

1) The fluid level of a tank should be within the specified range of "HIGH" and "LOW." When exceeding the specified level, the circulating fluid will overflow.

- 2) Remove the air.

Conduct a trial operation, looking at the fluid level.

Since the fluid level will go down when the air is removed from the user's piping system, supply water once again when the fluid level is reduced. When there is no reduction in the fluid level, the job of removing the air is completed. Pump can be operated independently.

2. Confirmation during operation

- Check the circulating fluid temperature.

The operating temperature range of the circulating fluid is between 15 and 25°C.

When the amount of heat generated from the user's equipment is greater than the product's capability, the circulating fluid temperature may exceed this range. Use caution regarding this matter.

3. Emergency stop method

- When an abnormality is confirmed, stop the machine immediately. After the machine has stopped, make sure to turn off the breaker of the user's equipment (on the upstream side).



HRL Series

Specific Product Precautions 5

Be sure to read this before handling the products. Refer to the back cover for safety instructions. For temperature control equipment precautions, refer to the “Handling Precautions for SMC Products” and the “Operation Manual” on the SMC website: <https://www.smcworld.com>

Operation Restart Time/Operation and Suspension Frequency

⚠ Caution

1. Wait five minutes or more before restarting operation after it has been stopped. If the operation is restarted within five minutes, the protection circuit may activate and the operation may not start properly.
2. Operation and suspension frequency should not exceed 10 times per day. Frequently switching between operation and suspension may result in the malfunction of the refrigeration circuit.

Protection Circuit

⚠ Caution

If operating in the conditions below, the protection circuit will activate and an operation may not be performed or will stop.

- Power supply voltage is not within the rated voltage range of $\pm 10\%$.
- In case the water level inside the tank is reduced abnormally.
- Circulating fluid temperature is too high.
- Compared to the cooling capacity, the heat generation amount of the user's equipment is too high.
- Ambient temperature is over 45°C.
- Ventilation grille is clogged with dust or dirt

Maintenance

⚠ Caution

<Periodical inspection every one month>

Clean the ventilation grille.

If the dustproof filter of air-cooled type product becomes clogged with dust or debris, a decline in cooling performance can result. In order to avoid deforming or damaging the dustproof filter, clean it with a long-haired brush or air gun.

<Periodical inspection every three months>

Inspect the circulating fluid.

1. When using tap water or deionized water
 - Replacement of circulating fluid
 Failure to replace the circulating fluid can lead to the development of bacteria or algae. Replace it regularly depending on your usage conditions.

<Periodical inspection during the winter season>

1. Make water-removal arrangements beforehand.

If there is a risk of the circulating fluid freezing when the product is stopped, release the circulating fluid in advance.

2. Contact a professional.

This product has an “anti-freezing function” and “warming-up function.” Read the operation manual carefully, and if any additional anti-freezing function (e.g. tape heater) is needed, ask for it from the vendor.

■ Refrigerant with GWP reference

Refrigerant	Global Warming Potential (GWP)		
	Regulation (EU) 2024/573, AIM Act 40 CFR Part 84	Fluorocarbon Emissions Control Act (Japan) GWP value labeled on products	GWP value to be used for reporting the calculated amount of leakage
R134a	1,430	1,430	1,300
R404A	3,922	3,920	3,940
R407C	1,774	1,770	1,620
R410A	2,088	2,090	1,920
R448A	1,386	1,390	1,270
R454C	146	145	146

* This product is hermetically sealed and contains fluorinated greenhouse gases (HFC). When this product is sold on the market in the EU after January 1, 2017, it needs to be compliant with the quota system of the F-Gas Regulation in the EU.

* See specification table for refrigerant used in the product.

Temperature Control Equipment

These safety instructions are intended to prevent hazardous situations and/or equipment damage. These instructions indicate the level of potential hazard with the labels of “**Caution**,” “**Warning**” or “**Danger**.” They are all important notes for safety and must be followed in addition to International Standards (ISO/IEC), and other safety regulations.

Safety Instructions

- Danger** : **Danger** indicates a hazard with a high level of risk which, if not avoided, will result in death or serious injury.
- Warning** : **Warning** indicates a hazard with a medium level of risk which, if not avoided, could result in death or serious injury.
- Caution** : **Caution** indicates a hazard with a low level of risk which, if not avoided, could result in minor or moderate injury.

Compliance Requirements

1. The use of SMC products with production equipment for the manufacture of weapons of mass destruction (WMD) or any other weapon is strictly prohibited.
2. The exports of SMC products or technology from one country to another are governed by the relevant security laws and regulations of the countries involved in the transaction. Prior to the shipment of a SMC product to another country, assure that all local rules governing that export are known and followed.

Limited warranty and Disclaimer/ Compliance Requirements

The product used is subject to the following “Limited warranty and Disclaimer” and “Compliance Requirements”.

Read and accept them before using the product.

Limited warranty and Disclaimer

- 1. Period**
The warranty period of the product is 1 year in service or 1.5 years after the product is delivered, whichever is first.
- 2. Scope**
For any failure reported within the warranty period which is clearly our responsibility, replacement parts will be provided. In that case, removed parts shall become the property of SMC.
This guarantee applies only to our product independently, and not to any other damage incurred due to the failure of the product.
- 3. Content**
The following situations are out of scope of this warranty.
 1. The product was incorrectly installed or connected with other equipment.
 2. The product was modified or altered in construction.
 3. The failure was a secondary failure of the product caused by the failure of equipment connected to the product.
 4. The failure was caused by a natural disaster such as an earthquake, typhoon, or flood, or by an accident or fire.
 5. The failure was caused by operation different from that shown in the Operation Manual or outside of the specifications.
 6. The checks and maintenance specified (daily checks and regular checks) were not performed.
 7. The failure was caused by the use of circulating fluid or facility water other than those specified.
 8. The failure occurred naturally over time (such as discoloration of a painted or plated face).
 9. The failure does not affect the functioning of the product (such as new sounds, noises and vibrations).
 10. The failure was due to the “Installation Environment” specified in the Operation Manual.
- 4. Disclaimer**
 1. Expenses for daily and regular checks
 2. Expenses for repairs performed by other companies
 3. Expenses for transfer, installation and removal of the product
 4. Expenses for replacement of parts other than those in this product, or for the supply of liquids
 5. Inconvenience and loss due to product failure (such as telephone bills, compensation for workplace closure, and commercial losses)

For warranted repair, please contact the supplier you purchased this product from.

Warning

1. The compatibility of the product is the responsibility of the person who designs the equipment or decides its specifications.

Since the product specified here is used under various operating conditions, its compatibility with specific equipment must be decided by the person who designs the equipment or decides its specifications based on necessary analysis and test results. The expected performance and safety assurance of the equipment will be the responsibility of the person who has determined its compatibility with the product. This person should also continuously review all specifications of the product referring to its latest catalog information, with a view to giving due consideration to any possibility of equipment failure when configuring the equipment.

2. Only personnel with appropriate training should operate machinery and equipment.

The product specified here may become unsafe if handled incorrectly. The assembly, operation and maintenance of machines or equipment including our products must be performed by an operator who is appropriately trained and experienced.

3. SMC products cannot be used beyond their specifications. They are not developed, designed, and manufactured to be used under the following conditions or environments. Use under such conditions or environments is not allowed.

1. Conditions and environments outside of the given specifications, or use outdoors or in a place exposed to direct sunlight.
2. Use for nuclear power, railways, aviation, space equipment, ships, vehicles, military application, equipment affecting human life, body, and property, combustion equipment, entertainment equipment, emergency shut-off circuits, press clutches, brake circuits, safety equipment, etc., and use for applications that do not conform to standard specifications such as catalogs and operation manuals.
3. Use for interlock circuits, except for use with double interlock such as installing a mechanical protection function in case of failure. Please periodically inspect the product to confirm that the product is operating properly.

Caution

SMC develops, designs, and manufactures products to be used for automatic control equipment, and provides them for peaceful use in manufacturing industries.

Use in non-manufacturing industries is not allowed.

Products SMC manufactures and sells cannot be used for the purpose of transactions or certification specified in the Measurement Act of each country.

The new Measurement Act prohibits use of any unit other than SI units in Japan.

Revision History

- | | |
|------------------|--|
| Edition B | <ul style="list-style-type: none">• A water-cooled refrigeration type has been added to the HRL100/200 series.• The number of pages has been increased from 28 to 45. |
|------------------|--|

 **Safety Instructions** Be sure to read the “Handling Precautions for SMC Products” (M-E03-3) and “Operation Manual” before use.