

Pressure Gauge for General Purpose /With limit indicator

G36, GA36

O.D.: ø37



G36-10-01

• Be sure to read the precautions on page 14-11-15 for selection and installation.

Standard Specifications

Model		G36	GA36
Type		Back side thread	Vertical side thread
Port size ⁽¹⁾		R 1/8 (Option M: With M5 female thread)	
Fluid ⁽²⁾		Air	
Indication precision		±3% F.S. (Full span)	
Material	Case (Surface treatment)	Aluminum die-casted (Black disulfide molybdenum coat treated)	Rolled steel (Black melamine painted)
	Clear cover	Polycarbonate (Part no.: G36-00-00-3)	
	Stud (Surface treatment)	Aluminum die-casted (Black disulfide molybdenum coat treated)	Brass
	Bourdon tube	Brass	
Weight (kg)		0.04	0.05
Applicable model		AC2000/2500/3000 AR2000/2500/3000 AW2000/3000	—

Note 1) When installing a pressure gauge, be careful not to fasten too tight. Excessive tightening will result in damage. Use a pipe tape for sealing. Recommended tightening torque is R 1/8: Set between 7 and 9 N·m.

Note 2) Not applicable to water as fluid because its stud is made from aluminum die-casted. Water may cause corrosion and block the air passage. Use a pressure gauge with wetted parts made from stainless steel, G46-□-X3. (Note: Take care when using G36-□-01M, whose wetted part is made from brass. Some corrosion may result.) Design system to not be affected by water hammer when using water as fluid. Similarly, when using other fluids, please consult with SMC, to prevent corrosion-related problems.

Model (Standard)

Model	Pressure range ^{Note)}	Indication unit	Connection thread	Note
	MPa			
G36-2-01	0 to 0.2	MPa	R 1/8	—
G36-4-01	0 to 0.4			
G36-7-01	0 to 0.7			
G36-10-01	0 to 1.0			
GA36-10-01	0 to 1.0			

Note) Do not apply pressure more than the maximum display pressure. This will cause a malfunction.

Model (Made to Order)

Other versions of this unit can be made on a made-to-order basis. Please consult with SMC for details, as delivery times may be extended.

Model	Pressure range ^{Note)}	Indication unit	Connection thread	Note
	MPa			
G36-10-01-X2	0 to 1.0	MPa	R 1/8	Plated stem (Ni)
G36-15-01	0 to 1.5			—

Note) Do not apply pressure more than the maximum display pressure. This will cause a malfunction.

How to Order

G **□** **36** — **10** — **01** **M** — **X2**

Pressure gauge • Size • Connection thread • Max. display pressure • Option

Symbol	Type
Nil	Back side thread
A	Vertical side thread

Symbol	Size
36	ø37.5

Symbol	Size
01	R1/8

Symbol	Unit: MPa
2	0.2
4	0.4
7	0.7
10	1.0
15	1.5

Symbol	Specifications
Nil	—
X2	Nickel plated
X4	Oil-free (Wetted parts degrease washing)

Note 1) X3 (wetted parts SUS) specifications is not available.
 Note 2) Cover ring assembly is not available.
 Note 3) Part number for pressure gauge with MPa-psi units is G□36-P**-*X30. This will no longer be sold for use in Japan after the new Weight and Measure Act has been implemented (October, 1999).

Symbol	Specifications
Nil	—
M	M5 (Female thread)

Note) Use M5 female thread when piping onto a panel.

Dimensions

G36

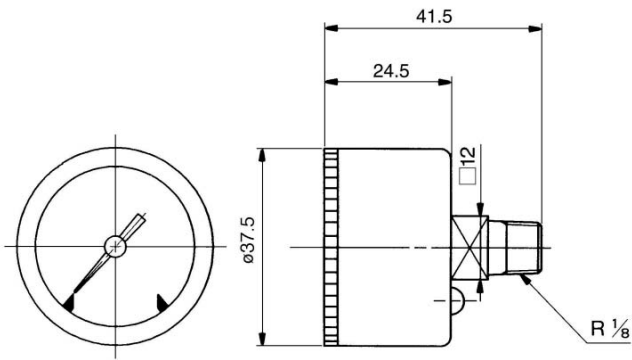

GA36

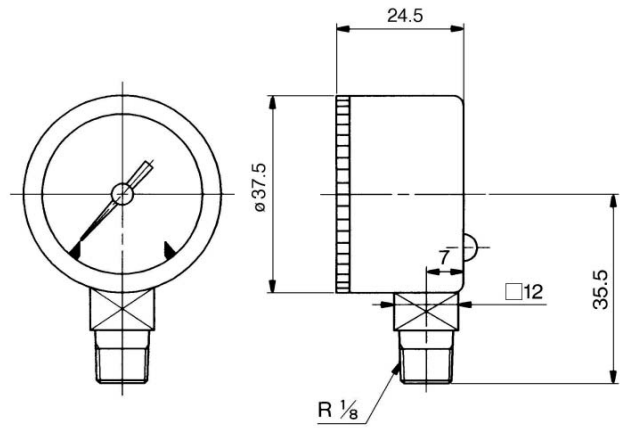



- F.R.L.
- AV
- AU
- AF
- AR
- IR
- VEX
- AMR
- ITV
- IC
- VBA
- VE□
- VY1
- G**
- PPA
- AL



Safety Instructions

These safety instructions are intended to prevent a hazardous situation and/or equipment damage. These instructions indicate the level of potential hazard by labels of "Caution", "Warning" or "Danger". To ensure safety, be sure to observe ISO 4414 ^{Note 1)}, JIS B 8370 ^{Note 2)} and other safety practices.

 **Caution** : Operator error could result in injury or equipment damage.

 **Warning** : Operator error could result in serious injury or loss of life.

 **Danger** : In extreme conditions, there is a possible result of serious injury or loss of life.

Note 1) ISO 4414: Pneumatic fluid power--General rules relating to systems.

Note 2) JIS B 8370: General Rules for Pneumatic Equipment

Warning

1. The compatibility of pneumatic equipment is the responsibility of the person who designs the pneumatic system or decides its specifications.

Since the products specified here are used in various operating conditions, their compatibility for the specific pneumatic system must be based on specifications or after analysis and/or tests to meet your specific requirements. The expected performance and safety assurance will be the responsibility of the person who has determined the compatibility of the system. This person should continuously review the suitability of all items specified, referring to the latest catalog information with a view to giving due consideration to any possibility of equipment failure when configuring a system.

2. Only trained personnel should operate pneumatically operated machinery and equipment.

Compressed air can be dangerous if an operator is unfamiliar with it. Assembly, handling or repair of pneumatic systems should be performed by trained and experienced operators.

3. Do not service machinery/equipment or attempt to remove components until safety is confirmed.

1. Inspection and maintenance of machinery/equipment should only be performed once measures to prevent falling or runaway of the driver objects have been confirmed.
2. When equipment is to be removed, confirm the safety process as mentioned above. Cut the supply pressure for this equipment and exhaust all residual compressed air in the system.
3. Before machinery/equipment is restarted, take measures to prevent shooting-out of cylinder piston rod, etc.

4. Contact SMC if the product is to be used in any of the following conditions:

1. Conditions and environments beyond the given specifications, or if product is used outdoors.
2. Installation on equipment in conjunction with atomic energy, railway, air navigation, vehicles, medical equipment, food and beverages, recreation equipment, emergency stop circuits, clutch and brake circuits in press applications, or safety equipment.
3. An application which has the possibility of having negative effects on people, property, or animals, requiring special safety analysis.



Common Precautions

Be sure to read before handling.

For detailed precautions on every series, refer to main text.

Selection

Warning

1. Confirm the specifications.

Products represented in this catalog are designed for use in compressed air applications only (including vacuum), unless otherwise indicated.

Do not use the product outside their design parameters.

Please contact SMC when using the products in applications other than compressed air (including vacuum).

Mounting

Warning

1. Instruction manual

Install the products and operate them only after reading the instruction manual carefully and understanding its contents. Also keep the manual where it can be referred to as necessary.

2. Securing the space for maintenance

When installing the products, please allow access for maintenance.

3. Tightening torque

When installing the products, please follow the listed torque specifications.

Piping

Caution

1. Before piping

Make sure that all debris, cutting oil, dust, etc., are removed from the piping.

2. Wrapping of pipe tape

When screwing piping or fittings into ports, ensure that chips from the pipe threads or sealing material do not get inside the piping. Also, when the pipe tape is used, leave 1.5 to 2 thread ridges exposed at the end of the threads.

Air Supply

Warning

1. Operating fluid

Please consult with SMC when using the product in applications other than compressed air (including vacuum).

Regarding products for general fluid, please ask SMC about applicable fluids.

2. Install an air dryer, aftercooler, etc.

Excessive condensate in a compressed air system may cause valves and other pneumatic equipment to malfunction.

Installation of an air dryer, after cooler etc. is recommended.

3. Drain flushing

If condensate in the drain bowl is not emptied on a regular basis, the bowl will over flow and allow the condensate to enter the compressed air lines.

If the drain bowl is difficult to check and remove, it is recommended that a drain bowl with the auto-drain option be installed.

For compressed air quality, refer to "Air Preparation Equipment" catalog.

4. Use clean air

If the compressed air supply is contaminated with chemicals, synthetic materials, corrosive gas, etc., it may lead to break down or malfunction.

Operating Environment

Warning

1. Do not use in environments where the product is directly exposed to corrosive gases, chemicals, salt water, water or steam.

2. Do not expose the product to direct sunlight for an extended period of time.

3. Do not use in a place subject to heavy vibrations and/or shocks.

4. Do not mount the product in locations where it is exposed to radiant heat.

Maintenance

Warning

1. Maintenance procedures are outlined in the operation manual.

Not following proper procedures could cause the product to malfunction and could lead to damage to the equipment or machine.

2. Maintenance work

If handled improperly, compressed air can be dangerous.

Assembly, handling and repair of pneumatic systems should be performed by qualified personnel only.

3. Drain flushing

Remove drainage from air filters regularly. (Refer to the specifications.)

4. Shut-down before maintenance

Before attempting any kind of maintenance make sure the supply pressure is shut of and all residual air pressure is released from the system to be worked on.

5. Start-up after maintenance and inspection

Apply operating pressure and power to the equipment and check for proper operation and possible air leaks. If operation is abnormal, please verify product set-up parameters.

6. Do not make any modifications to be product.

Do not take the product apart.