

Low Profile Guide Cylinder with Lock

Series *MLGP*

ø20, ø25, ø32, ø40, ø50, ø63, ø80, ø100



Drop prevention when supply pressure falls or residual pressure is released

Drop prevention for press fitting jig

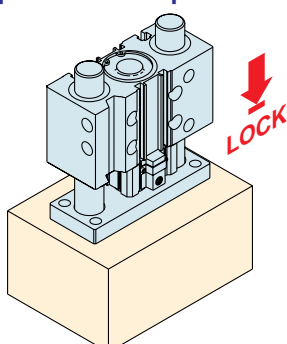

Drop prevention for lifter

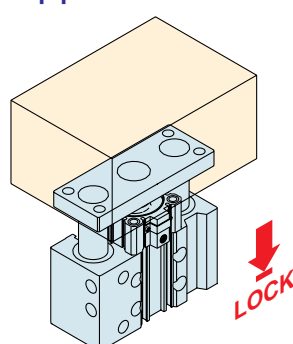

Holding a clamped condition

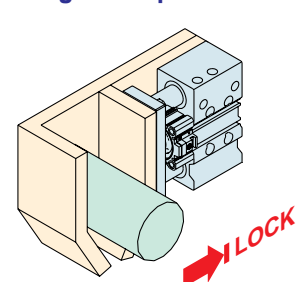

Locking is possible at any

Can be locked at any desired position

- Drop prevention for mid-stroke emergency stops
- Locking position can be changed to accommodate external stopper positions and thickness of clamped work pieces

← Extension locking

Retraction locking →

Drop prevention for press fitting jig

Drop prevention for lifter

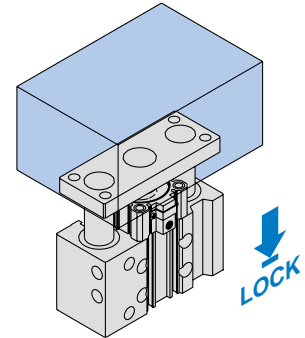
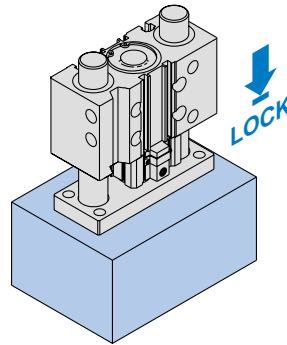

Holding a clamped condition

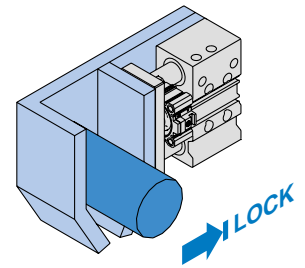

Low Profile Guide Cylinder with Lock

Series *MLGP*

∅20, ∅25, ∅32, ∅40, ∅50, ∅63, ∅80, ∅100

Simple construction

Simple and reliable locking system

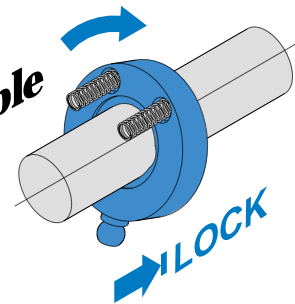

Locked

Unlocked

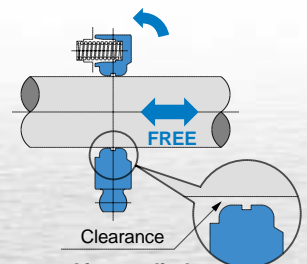
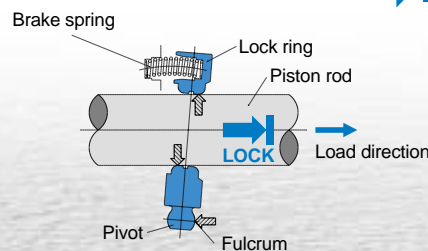

Unlocking port: Air exhausted

1. The lock ring is tilted by the spring force.
2. The tilting is increased by the load and the piston rod is securely locked.

Unlocking port: Air supplied

1. The lock ring becomes perpendicular to the piston rod, creating clearance between the piston rod and lock ring, which allows the piston rod to move freely.

position within the entire stroke

Low profile with compact lock unit

Lock unit length: A/26.5mm to 51.5mm

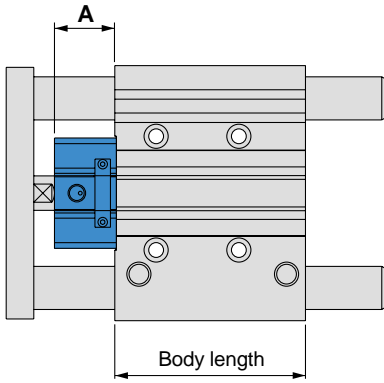

Bore size (mm)	A (mm)
20	26.5
25	30.5
32	31.5
40	34
50	35
63	38
80	43
100	51.5

Body length is the same as the standard MGP

Easy manual unlocking

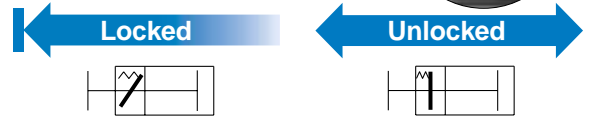

Ø40 to Ø100

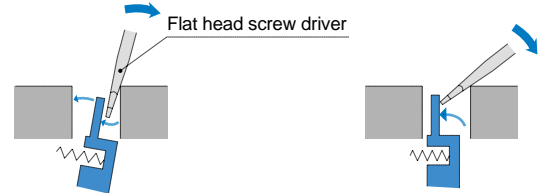

Ø20 to Ø32

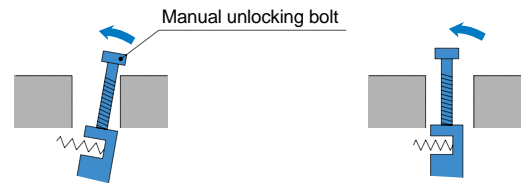

Locking direction is selectable

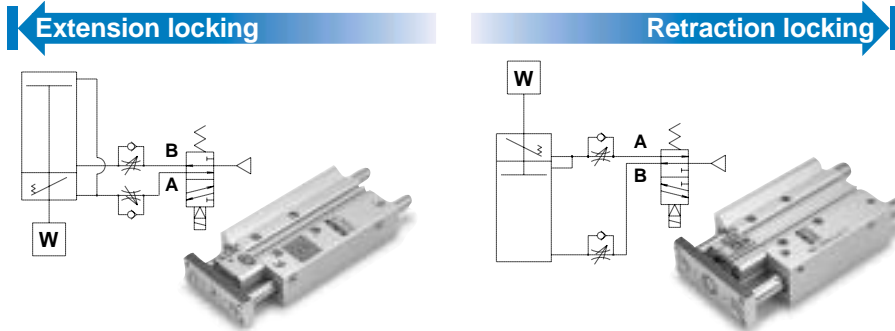

Four types of mounting

- Easy positioning
- Knock pin holes provided on each mounting surface

Top mount Side mount
Side mount using T-slot
Bottom mount

Two types of guide rod bearing for different applications

Slide bearing

Excellent wear resistance allows use with high loads.

Ball bushing

Provides high precision and smooth operation.

Wide variations from Ø20 to Ø100

Series	Bearing	Locking direction	Bore size (mm)	Standard stroke (mm)														
				20	25	30	40	50	75	100	125	150	175	200	250	300	350	
MLGP	Slide bearing	Extension locking	20	•		•	•	•	•	•	•	•	•	•	•	•	•	
			25	•		•	•	•	•	•	•	•	•	•	•	•	•	
			32		•			•	•	•	•	•	•	•	•	•	•	•
			40		•			•	•	•	•	•	•	•	•	•	•	•
	Ball bushing	Retraction locking	50		•			•	•	•	•	•	•	•	•	•	•	
			63		•			•	•	•	•	•	•	•	•	•	•	
			80		•			•	•	•	•	•	•	•	•	•	•	•
			100					•	•	•	•	•	•	•	•	•	•	•

Series MLGP Model Selections

Model Selection Precautions

⚠ Caution

1. To prevent exceeding the maximum speed during the selection, be sure to adjust the speed controller so that moving the entire load transfer distance takes no less than the transfer time.
2. For an intermediate stroke product with spacers installed, select using the base model stroke.

Step 1 Find the maximum load speed V.

Find the maximum load speed V [mm/s] with formula (1) below.

The maximum load speed V [mm/s] is approximately equal to $V_1 \times 1.4$ (1)

V_1 : Average load speed [mm/s]

$$V_1 = st/t$$

st: Load transfer distance [mm]

t: Load transfer time [s]

Step 2 Find the cylinder bore size.

1. For vertical mounting

- (1) From Table 1, find applicable selection graphs based on the maximum load speed "V", mounting orientation, and bearing type.
- (2) From the graphs chosen in (1), select the appropriate graph based on the stroke, and then find the intersecting point of the load weight "m" and eccentric distance " λ ".
- (3) Compare the intersecting point with the line chart for the operating pressure "P". Select the bore size from the line chart above the intersecting point.

2. For horizontal mounting

- (1) From Table 1, find applicable selection graphs based on the maximum load speed "V" and bearing type.
- (2) From the graphs chosen in (1), select the appropriate graph based on the distance " λ " between the plate and load center of gravity, then find the intersecting point of the load weight "m" and stroke.
- (3) Compare the intersecting point with the line chart. Select the bore size from the line chart above the intersecting point.

Selecting Conditions/Table 1

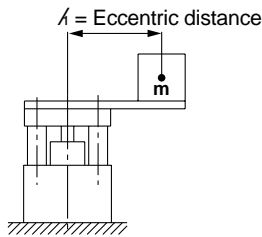
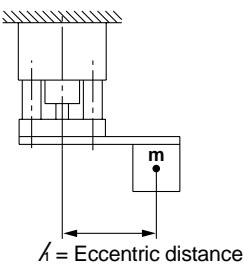
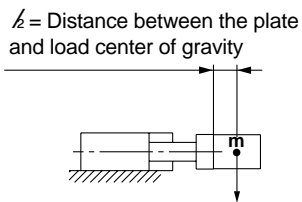
	Vertical				Horizontal	
	Upward facing		Downward facing			
Mounting orientation						
Maximum load speed V	50 to 200mm/s	201 to 400mm/s	50 to 200mm/s	201 to 400mm/s	50 to 200mm/s	201 to 400mm/s
Graph (Slide bearing type)	1, 2	3, 4	13, 14	15, 16	25, 26	27, 28
Graph (Ball bushing type)	5 to 8	9 to 12	17 to 20	21 to 24	29, 30	31, 32

Selection Example 1 (Vertical Upward Mounting)

Selecting conditions

- Mounting:** Vertical upward facing
- Bearing type:** Ball bushing
- Stroke:** 50mm
- Load transfer time t:** 0.5s
- Load weight m:** 15kg
- Eccentric distance λ :** 50mm
- Operating pressure P:** 0.5MPa

- Step 1:** Find the maximum load speed "V" from formula (1).
Based on the stroke (load transfer distance) of 50mm and load transfer time of 0.5s, the maximum load speed is approximately equal to $50/0.5 \times 1.4$, which is approximately 140mm/s.
- Step 2:** Based on the maximum load speed found in Step 1, mounting orientation, and guide type, graphs 5 to 8 are selected. Then, based on the 50mm stroke, graph 7 is selected from the group. Find the intersecting point of the load weight of 15kg and the eccentric distance of 50mm. Since the operating pressure is 0.5MPa, the bore size of $\phi 80$ mm, model MLGPL80-50-B, is selected.

7 50mm stroke or less $V = 200\text{mm/s}$ — 0.4MPa
----- 0.5MPa or more

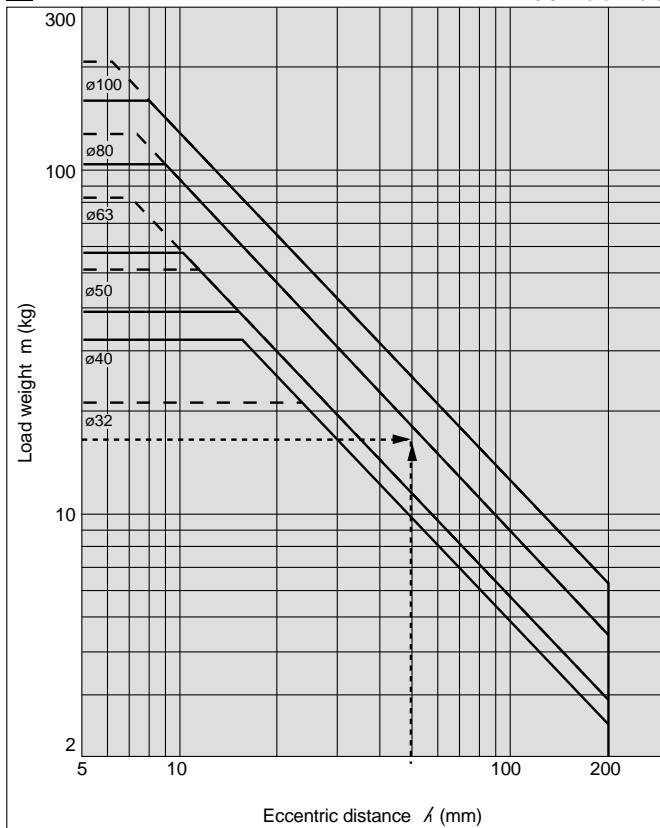

Selection Example 2 (Horizontal Mounting)

Selecting conditions

- Mounting:** Horizontal
- Bearing type:** Slide bearing
- Stroke:** 100mm
- Load transfer time t:** 0.5s
- Load weight m:** 6kg
- Eccentric distance between the plate and load center of gravity λ :** 50mm
- Operating pressure P:** 0.4MPa

- Step 1:** Find the maximum load speed "V" from formula (1).
Based on the stroke (load transfer distance) of 100mm and load transfer time of 0.5s, the maximum load speed is approximately equal to $100/0.5 \times 1.4$, which is approximately 280mm/s.
- Step 2:** Based on the maximum load speed found in Step 1, mounting orientation, and guide type, graphs 27 and 28 are selected. Then, based on the distance of 50mm between the plate and load center of gravity, graph 27 is selected from the two graphs. Find the intersecting point of the load weight of 6kg and the 100mm stroke. The bore size of $\phi 40$ mm, model MLGPM40-50-□, is selected.

27 $\lambda = 50\text{mm}$ $V = 400\text{mm/s}$ Horizontal mounting

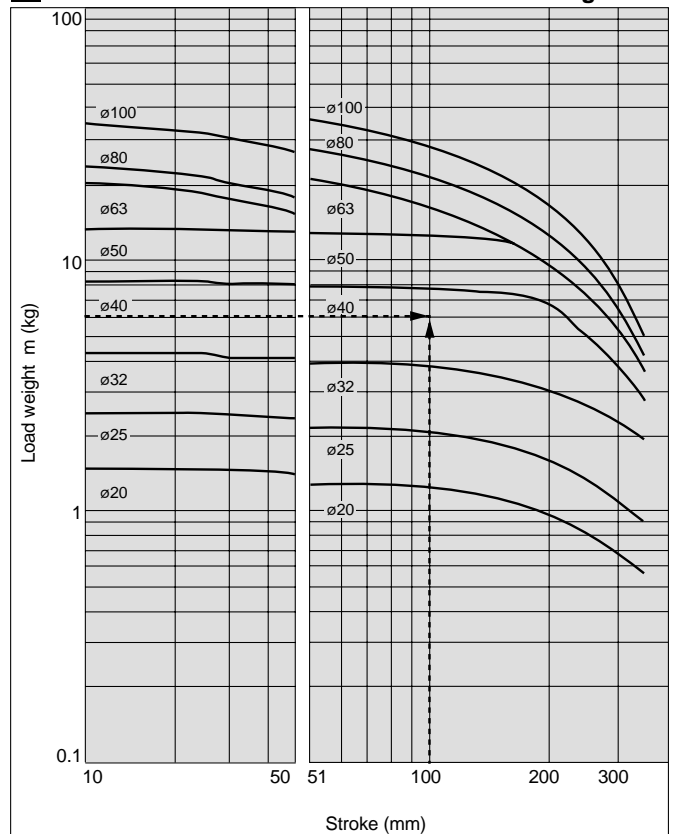

Series MLGP

Vertical Upward Mounting Slide Bearing

Operating pressure: 0.4MPa
 Operating pressure: 0.5MPa or more

MLGPM20 to 100

1 50mm stroke or less V = 200mm/s

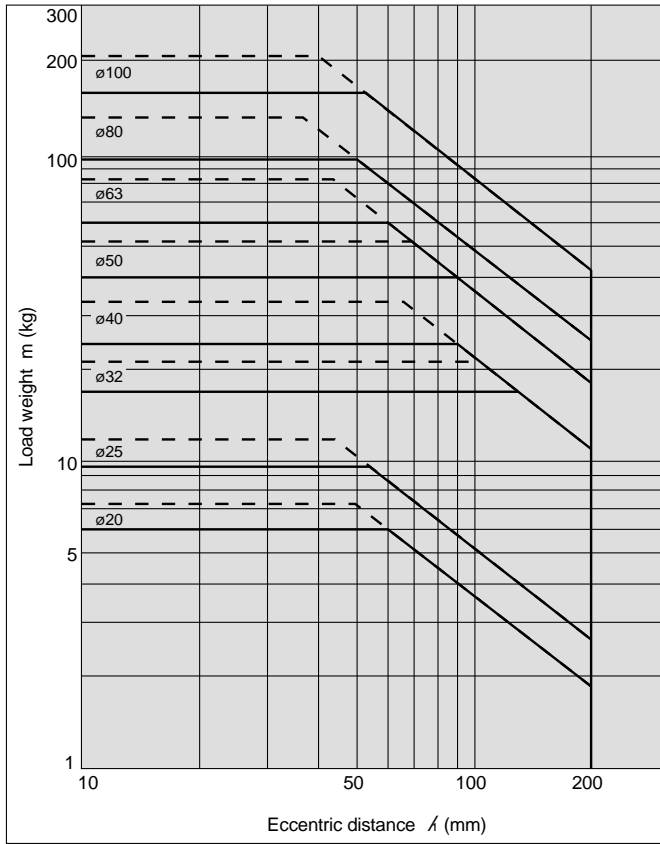

2 Over 50mm stroke V = 200mm/s

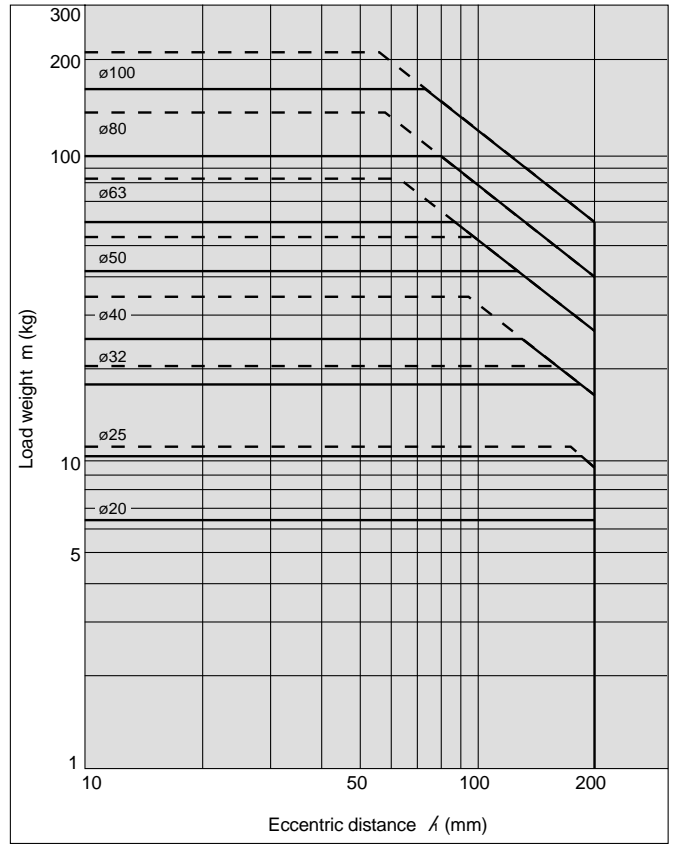

3 50mm stroke or less V = 400mm/s

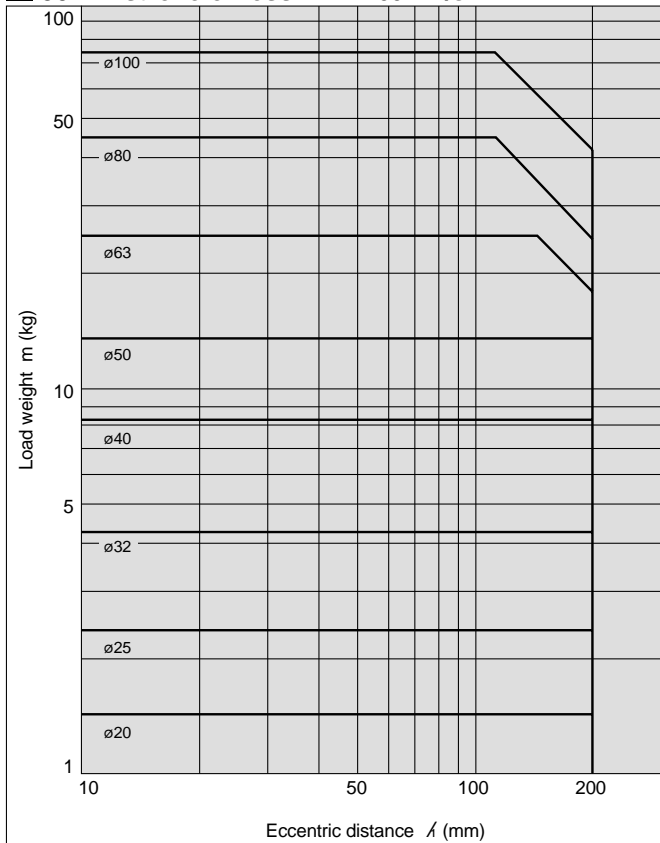

4 Over 50mm stroke V = 400mm/s

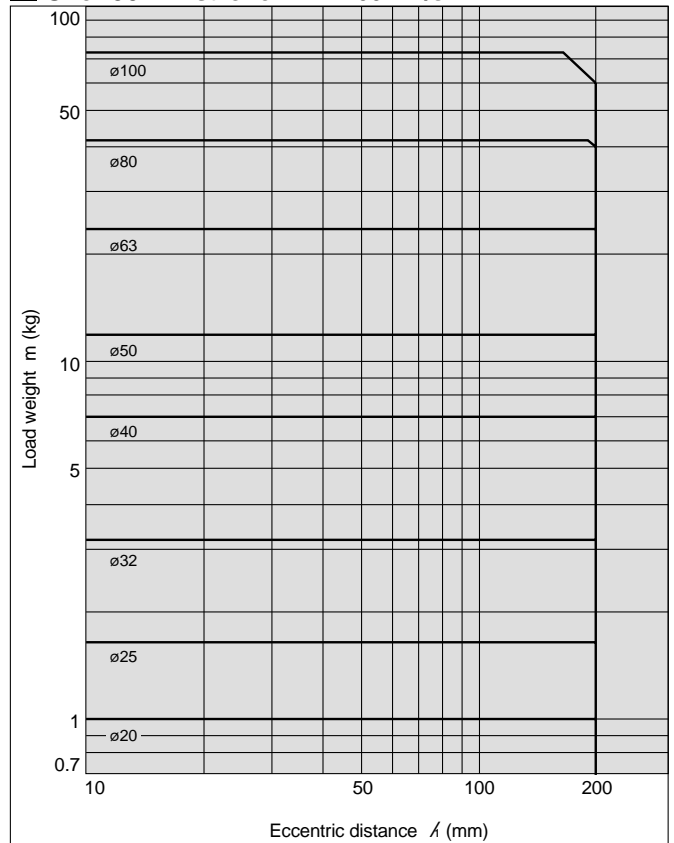

Vertical Upward Mounting **Ball Bushing**

—— Operating pressure: 0.4MPa
 - - - - Operating pressure: 0.5MPa or more

MLGPL20, 25

5 30mm stroke or less V = 200mm/s

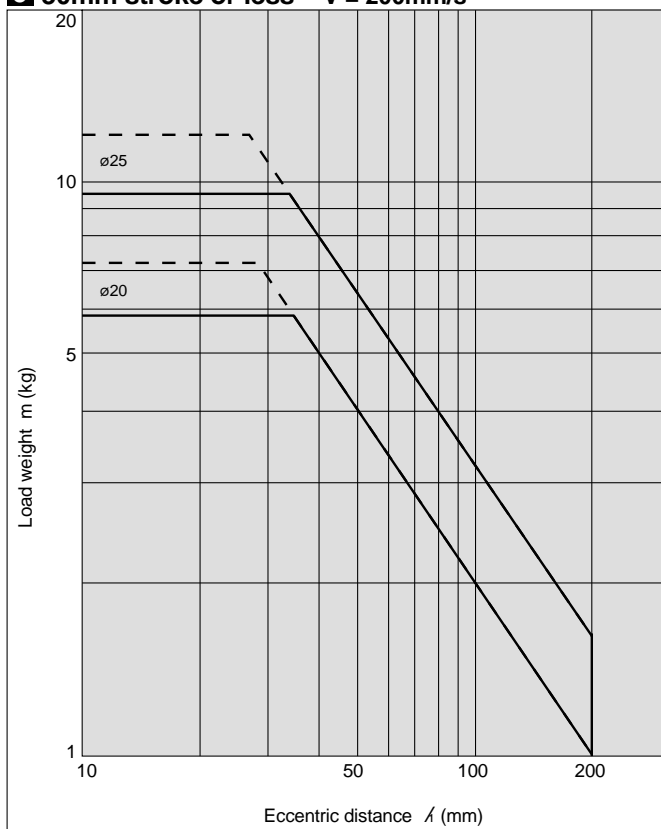

6 Over 30mm stroke V = 200mm/s

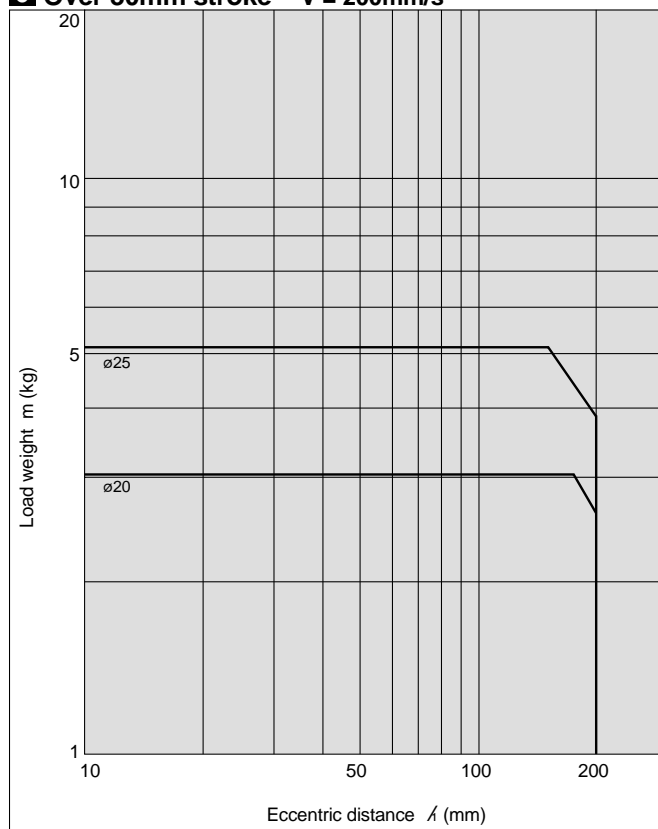

MLGPL32 to 100

7 50mm stroke or less V = 200mm/s

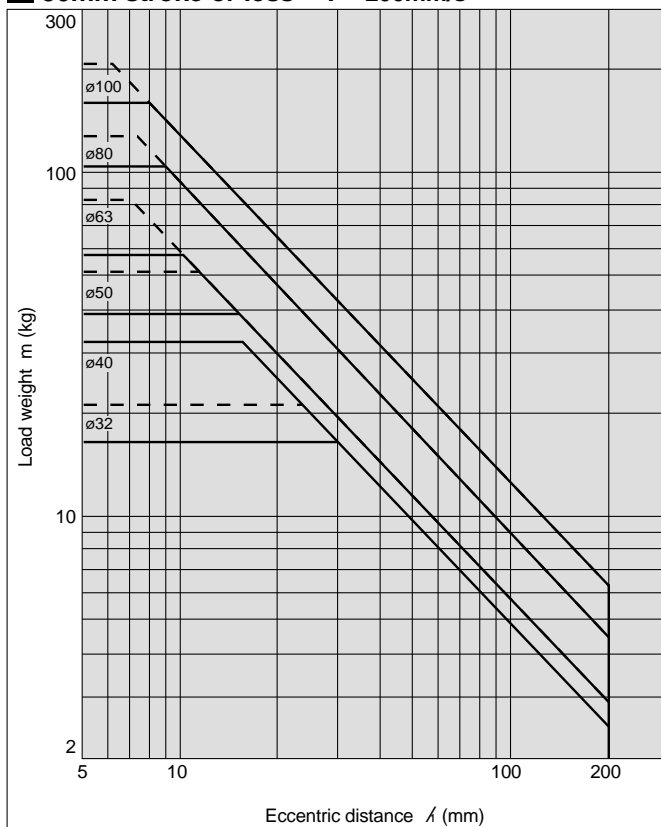

8 Over 50mm stroke V = 200mm/s

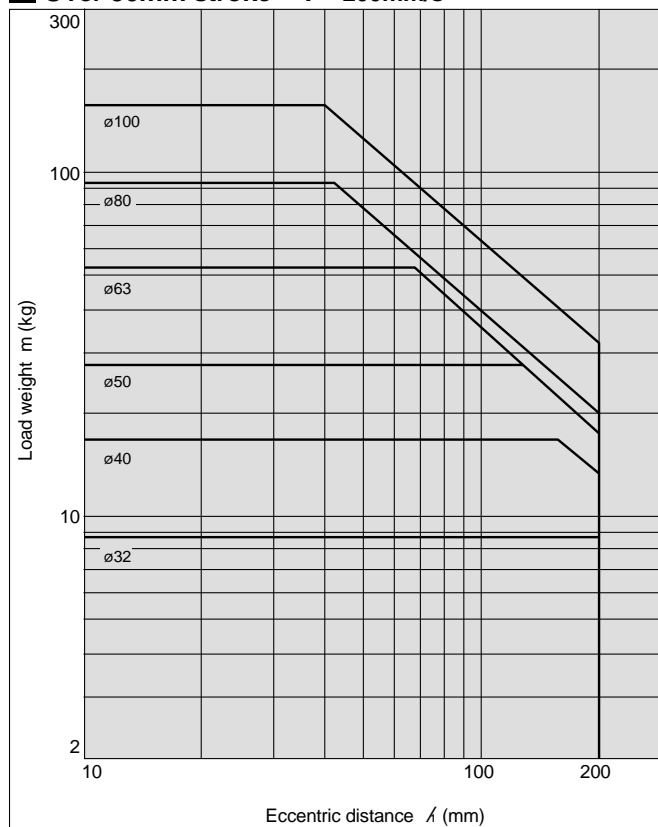

Series MLGP

Vertical Upward Mounting **Ball Bushing**

Operating pressure: 0.4MPa

MLGPL20, 25

9 30mm stroke or less V = 400mm/s

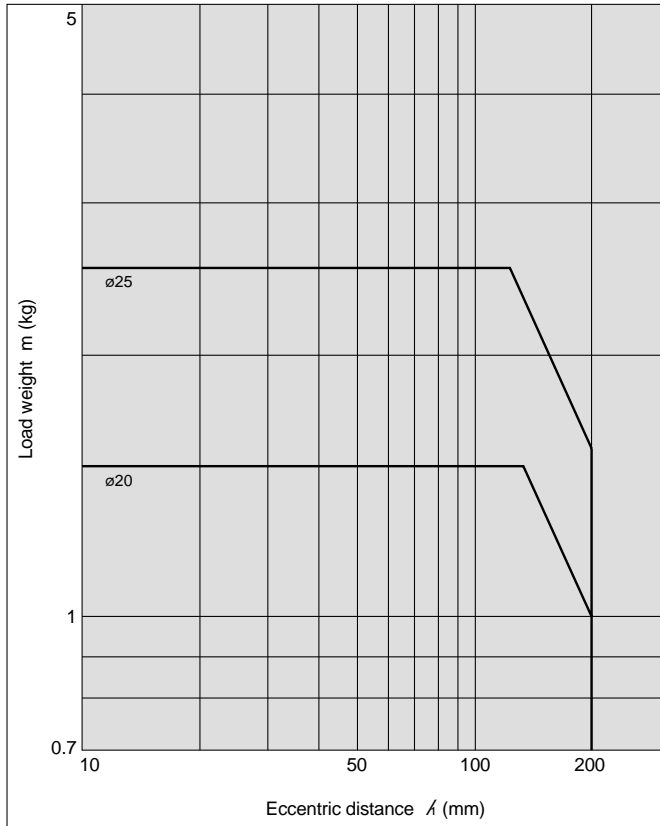

10 Over 30mm stroke V = 400mm/s

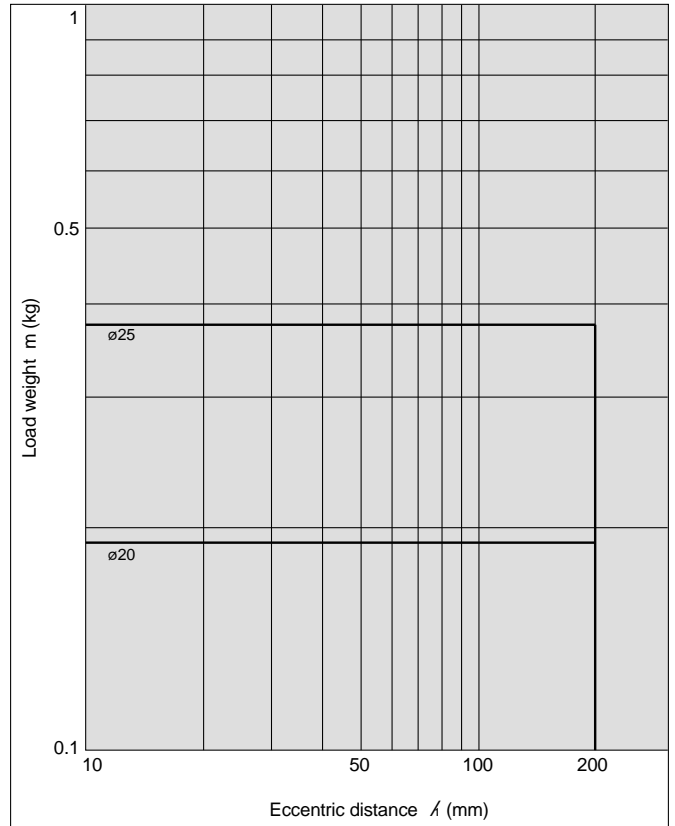

MLGPL32 to 100

11 50mm stroke or less V = 400mm/s

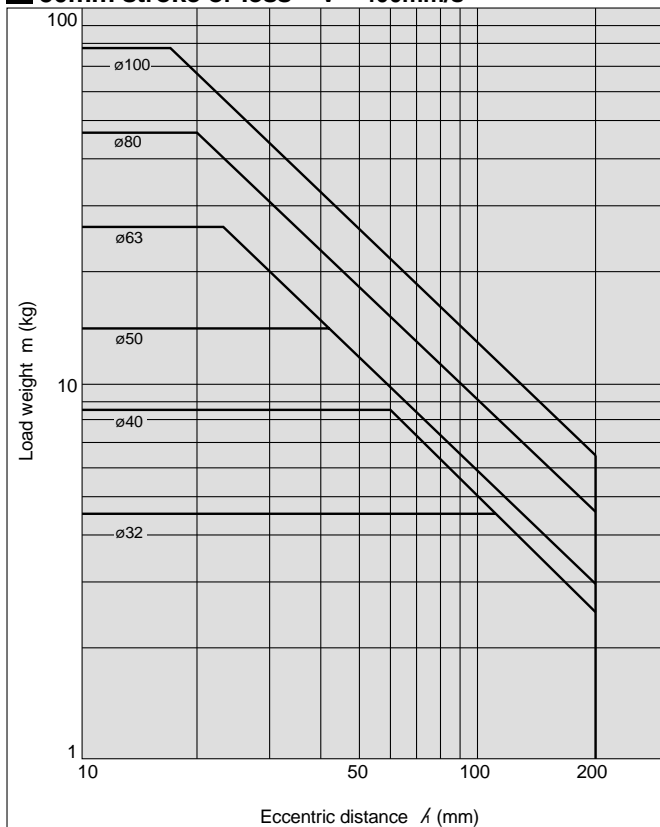

12 Over 50mm stroke V = 400mm/s

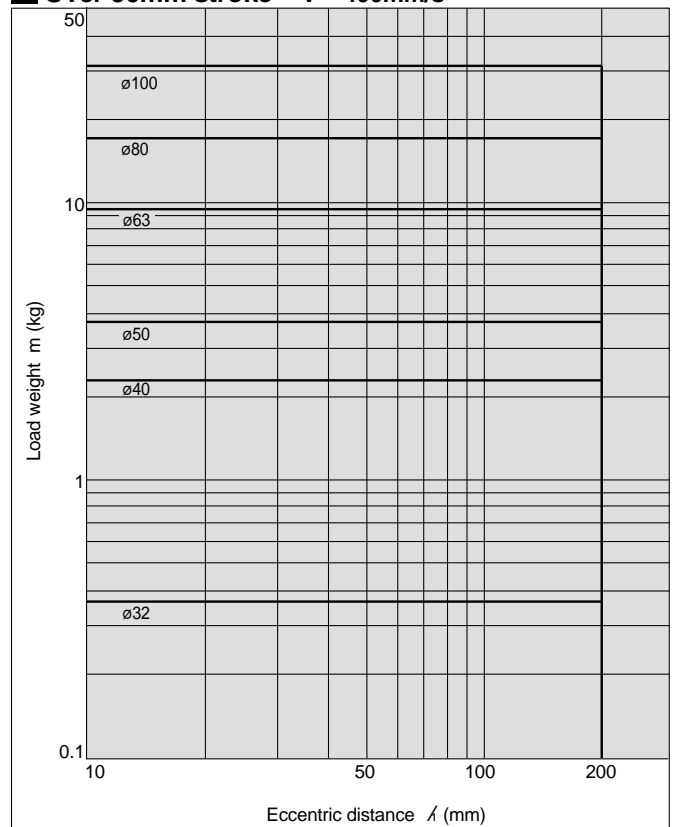

Vertical Downward Mounting **Slide Bearing**

—— Operating pressure: 0.4MPa
 - - - - Operating pressure: 0.5MPa or more

MLGPM20 to 100

13 50mm stroke or less V = 200mm/s

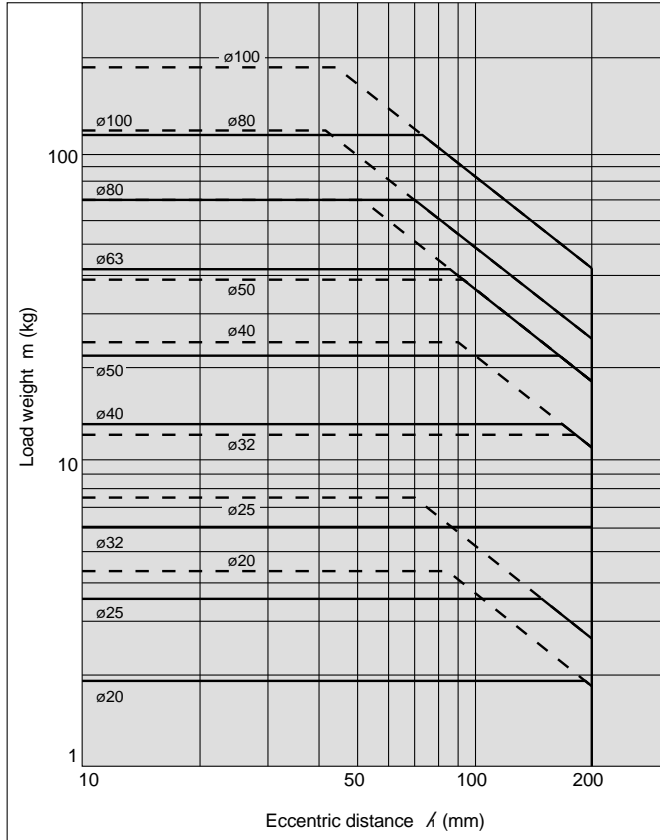

14 Over 50mm stroke V = 200mm/s

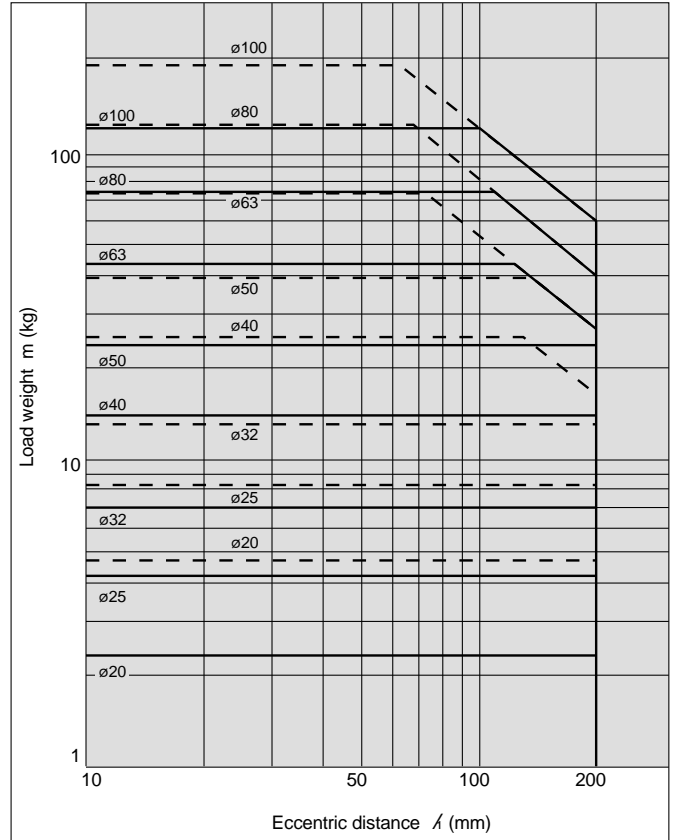

15 50mm stroke or less V = 400mm/s

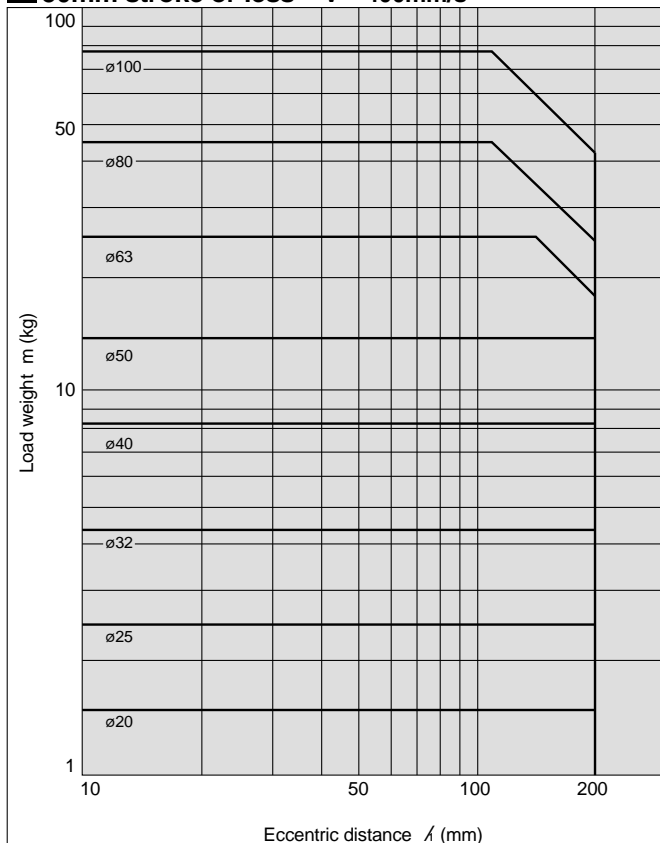

16 Over 50mm stroke V = 400mm/s

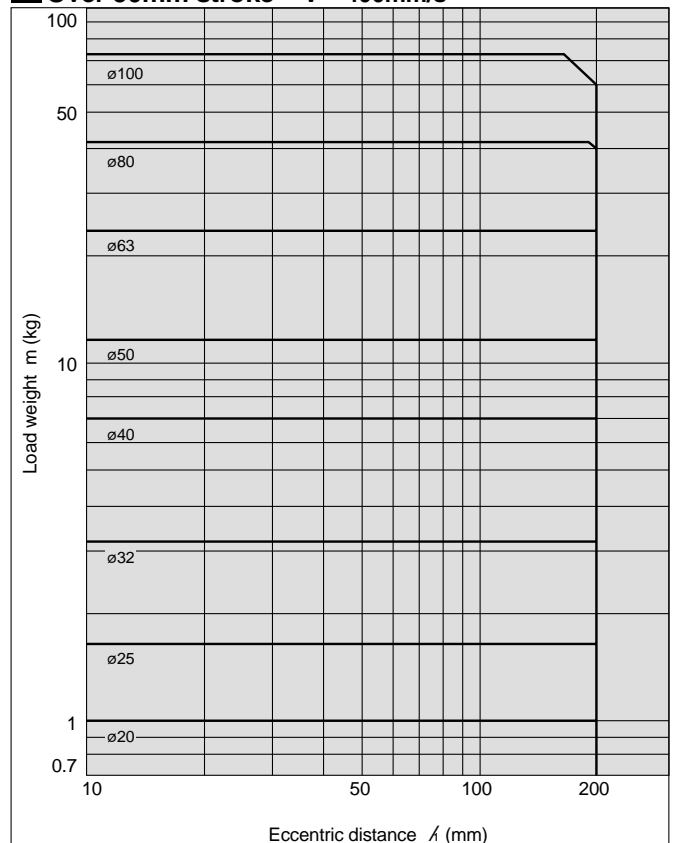

Series MLGP

Vertical Downward Mounting **Ball Bushing**

—— Operating pressure: 0.4MPa
 - - - - Operating pressure: 0.5MPa or more

MLGPL20, 25

17 30mm stroke or less V = 200mm/s

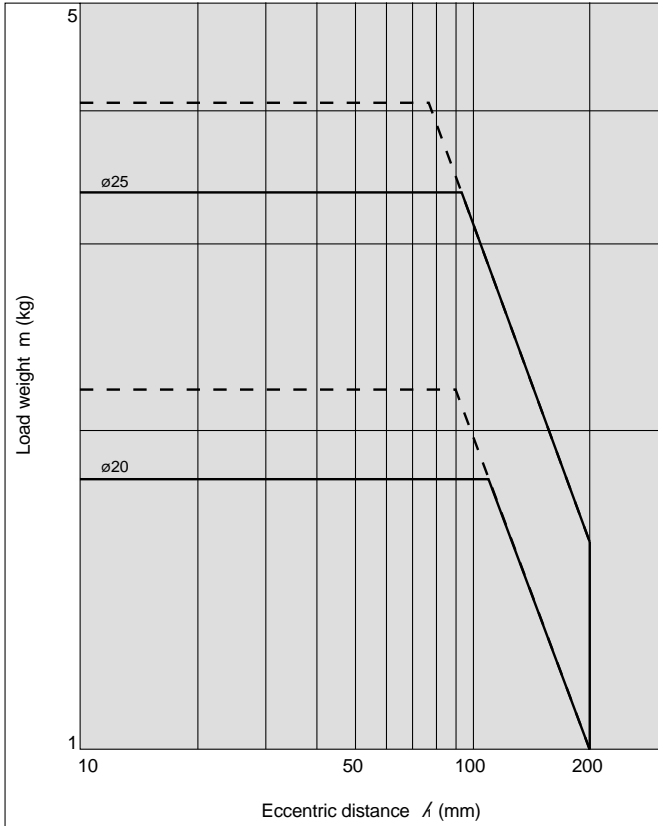

18 Over 30mm stroke V = 200mm/s

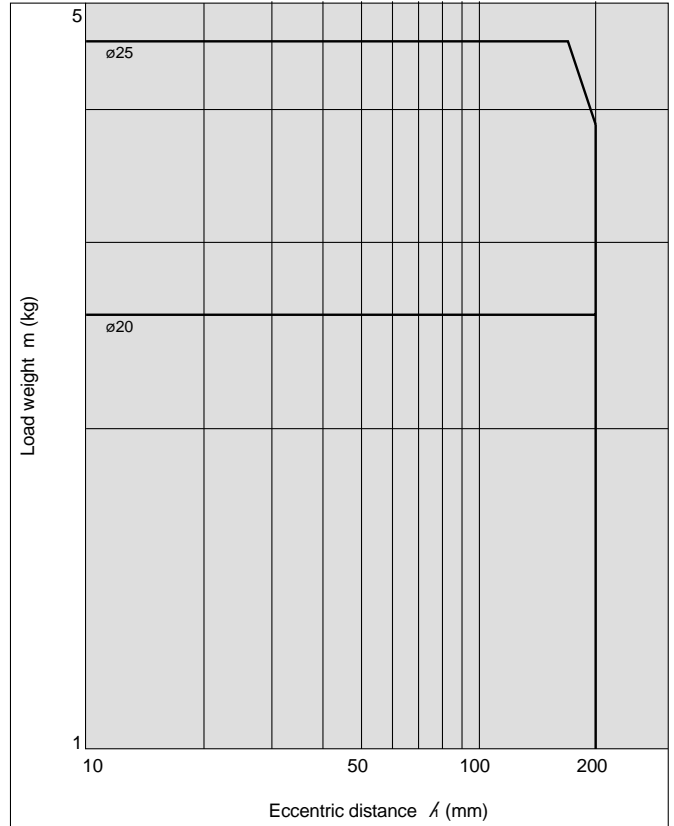

MLGPL32 to 100

19 50mm stroke or less V = 200mm/s

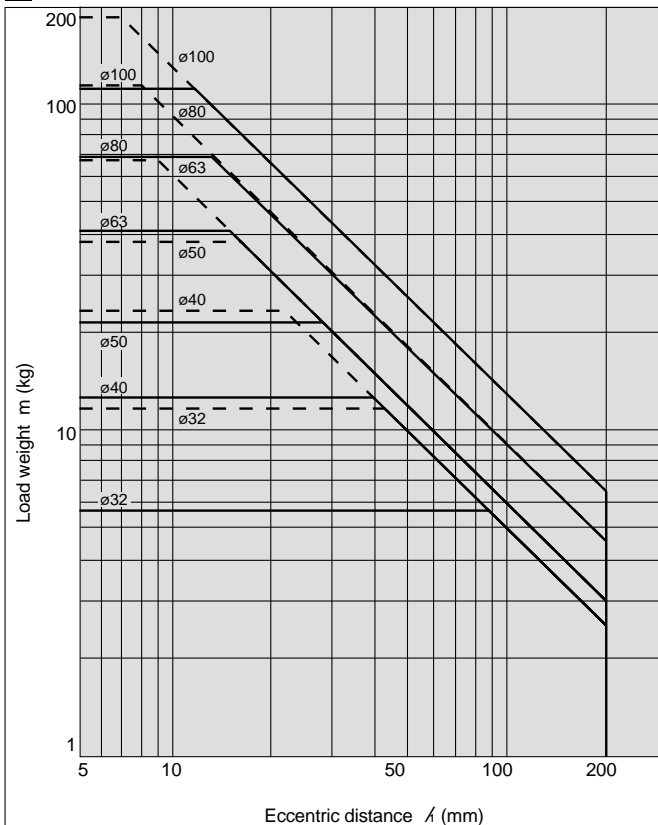

20 Over 50mm stroke V = 200mm/s

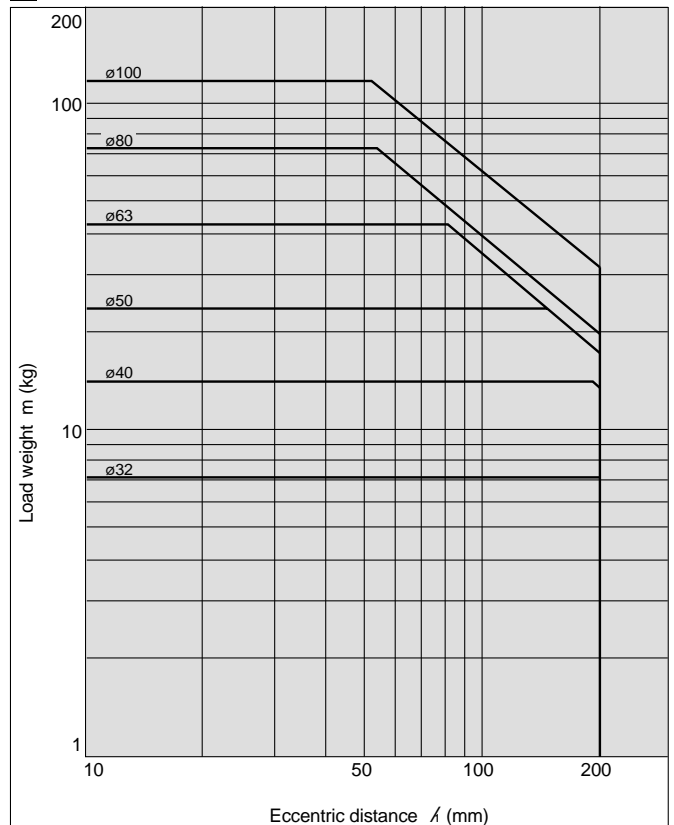

Vertical Downward Mounting **Ball Bushing**

— Operating pressure: 0.4MPa

MLGPL20, 25

21 30mm stroke or less V = 400mm/s

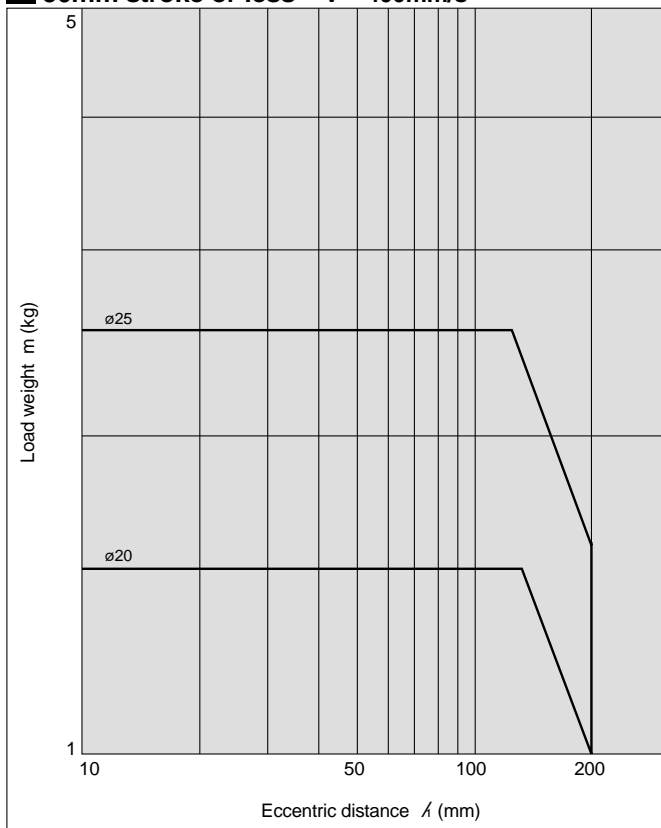

22 Over 30mm stroke V = 400mm/s

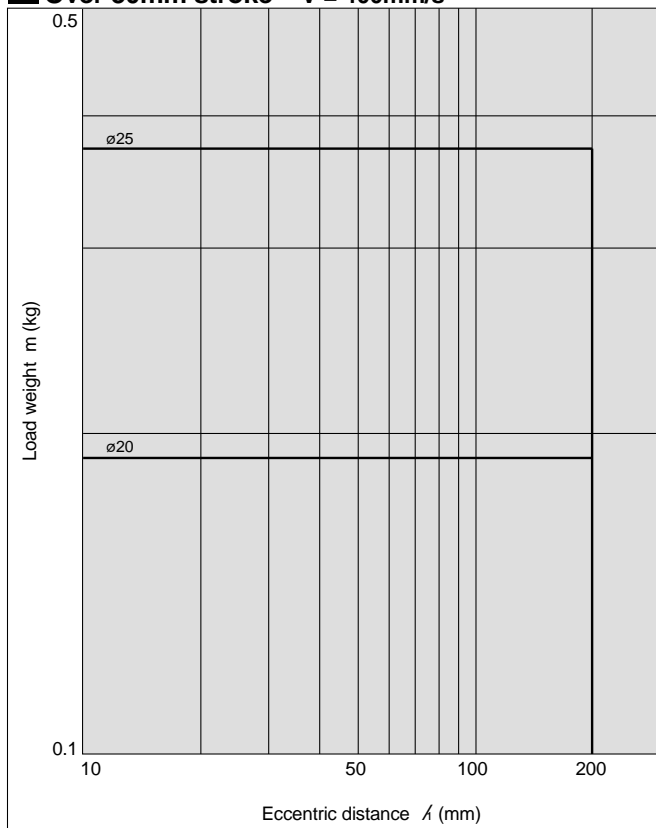

MLGPL32 to 100

23 50mm stroke or less V = 400mm/s

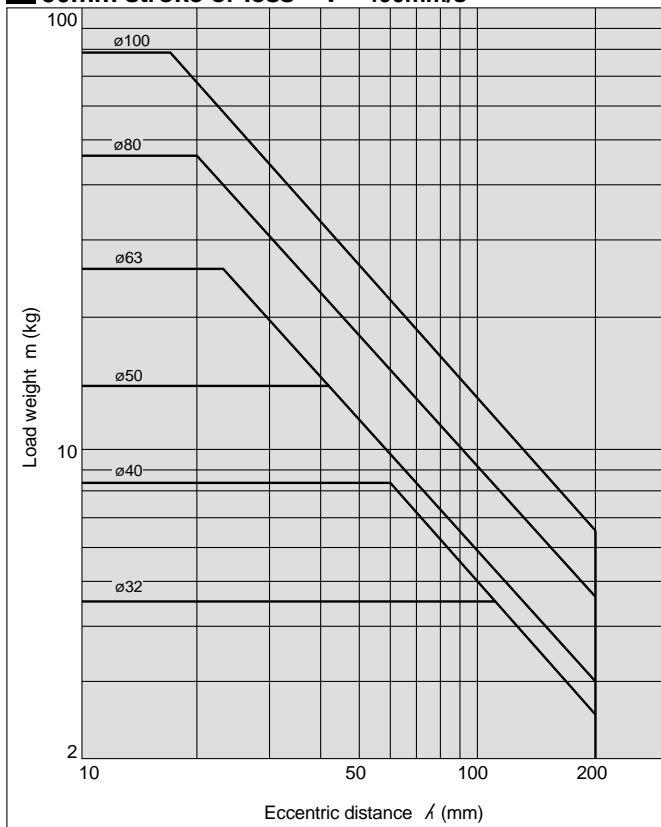

24 Over 50mm stroke V = 400mm/s

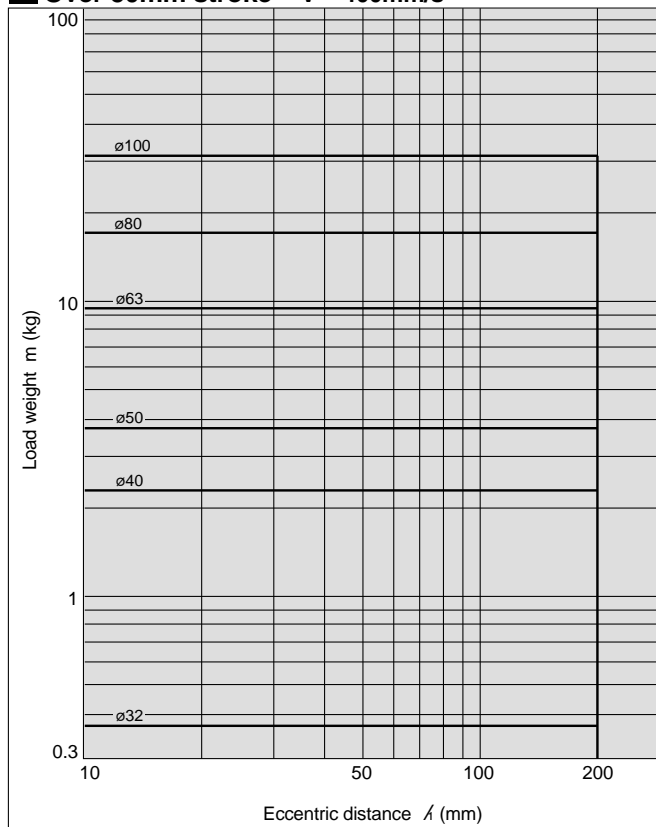

Series MLGP

Horizontal Mounting **Slide Bearing**

MLGPM20 to 100

25 $l/2 = 50\text{mm}$ $V = 200\text{mm/s}$

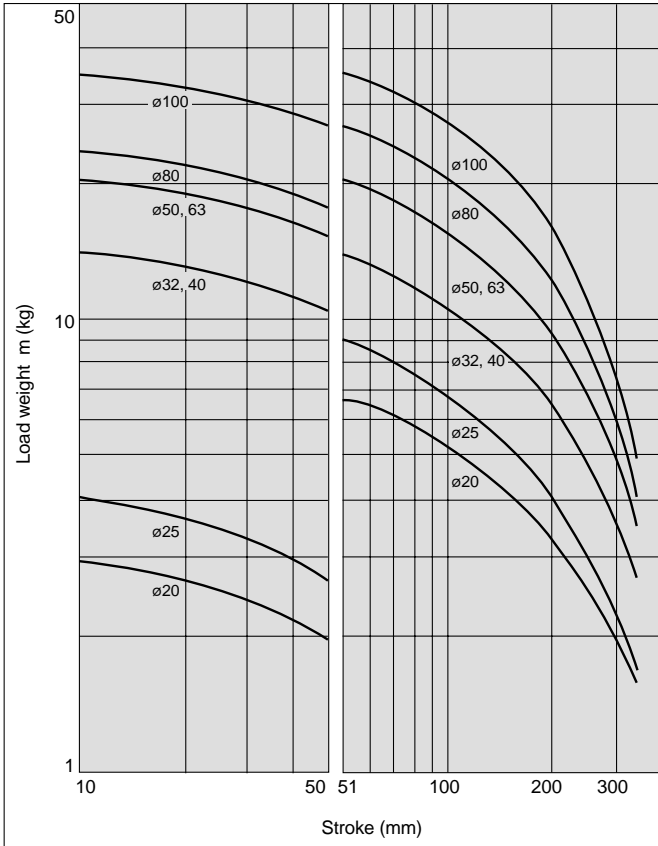

26 $l/2 = 100\text{mm}$ $V = 200\text{mm/s}$

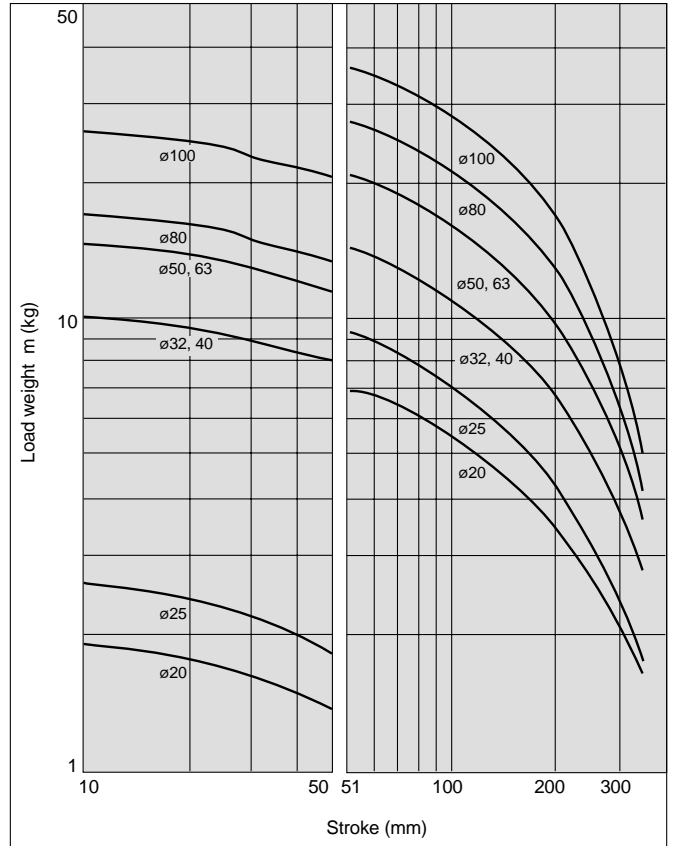

27 $l/2 = 50\text{mm}$ $V = 400\text{mm/s}$

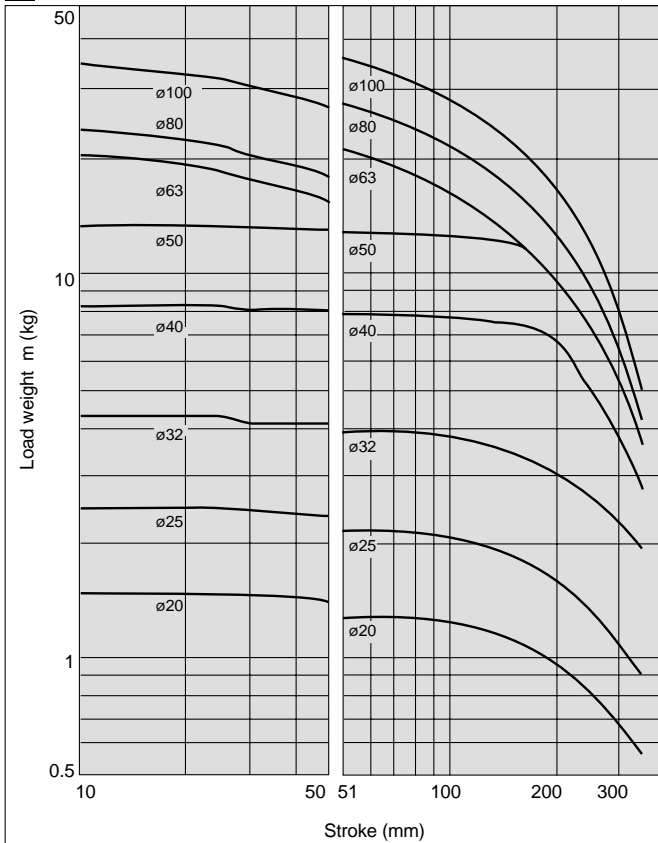

28 $l/2 = 100\text{mm}$ $V = 400\text{mm/s}$

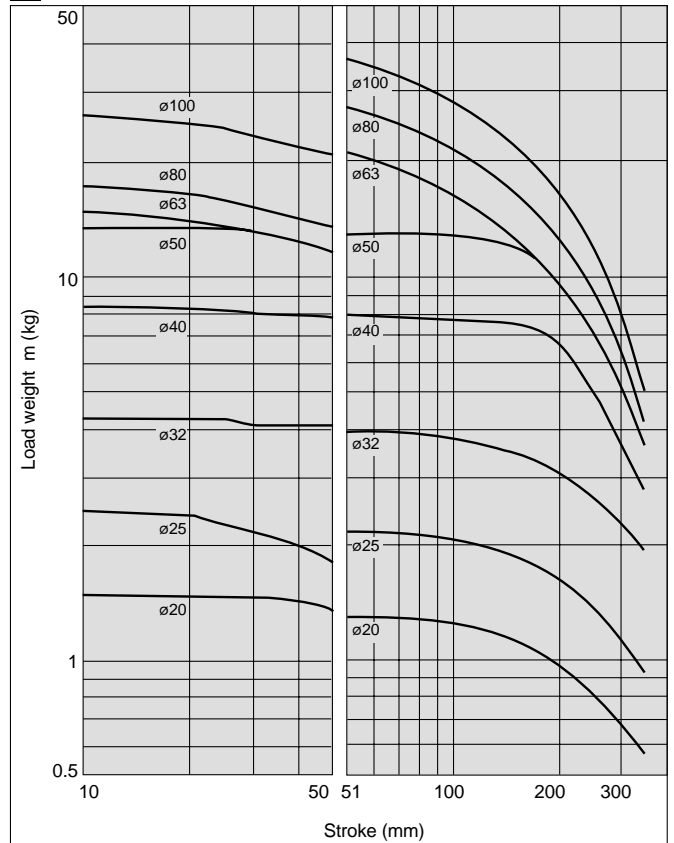

Horizontal Mounting **Ball Bushing**

29 $l = 50\text{mm}$, $V = 200\text{m/s}$

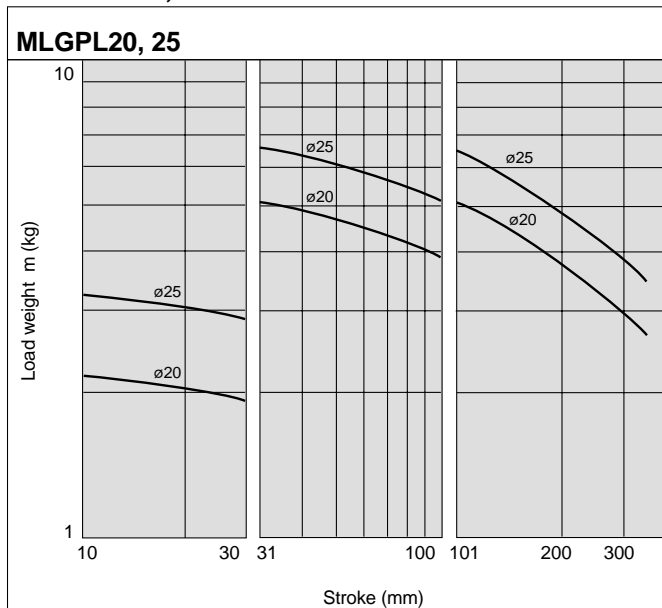

30 $l = 100\text{mm}$, $V = 200\text{m/s}$

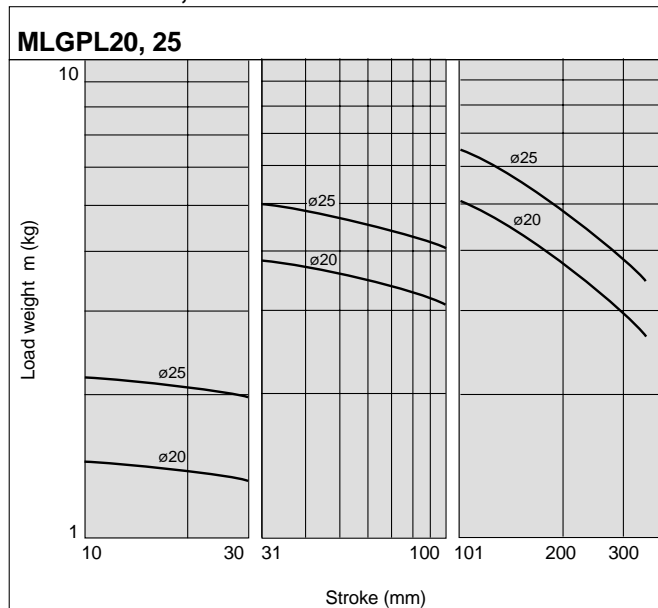

MLGPL32 to 63

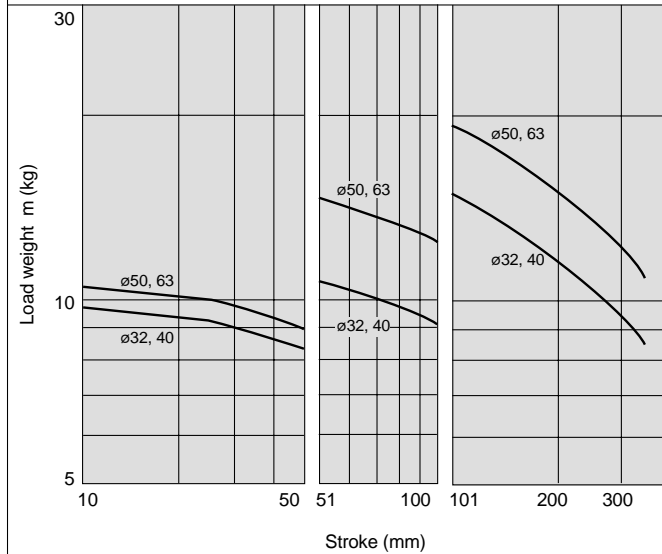

MLGPL32 to 63

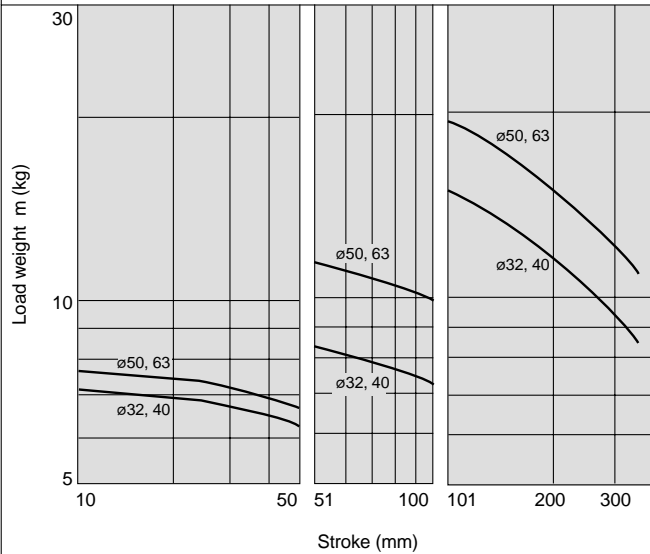

MLGPL80, 100

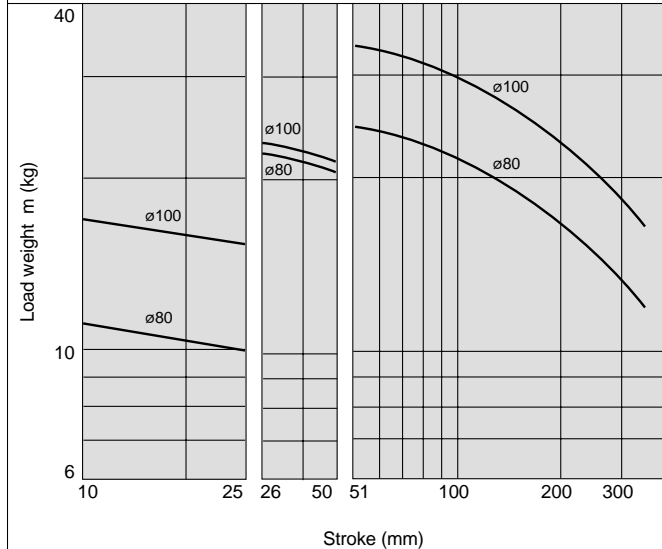

MLGPL80, 100

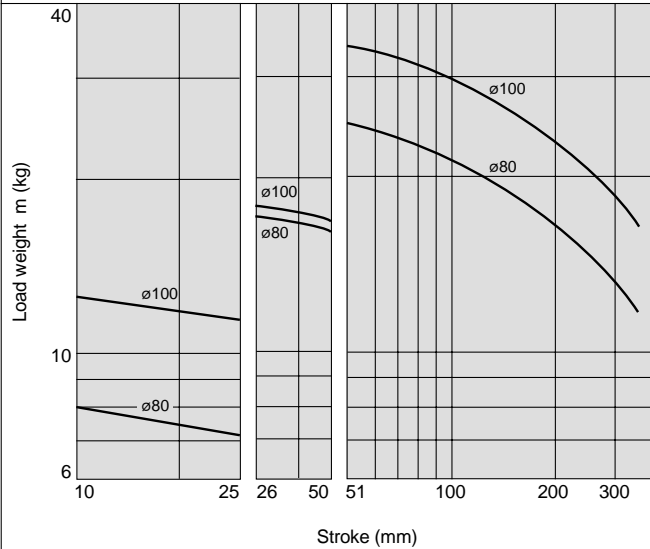

Series MLGP

Horizontal Mounting **Ball Bushing**

31 $l = 50\text{mm}$, $V = 400\text{m/s}$

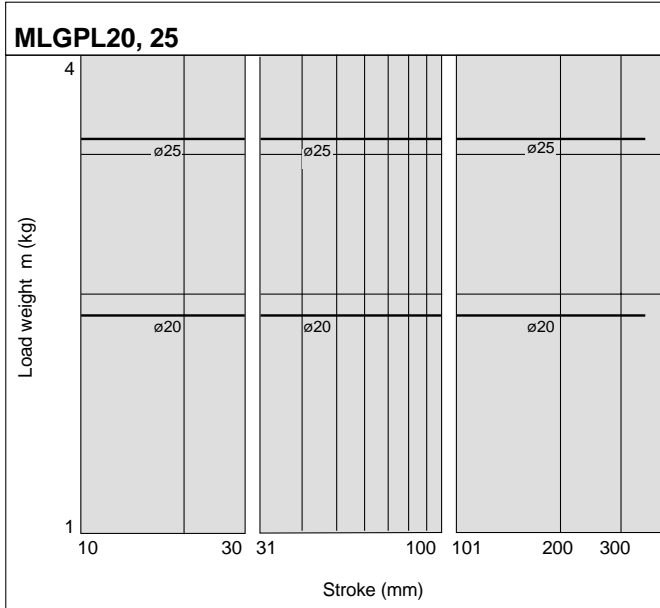

32 $l = 100\text{mm}$, $V = 400\text{m/s}$

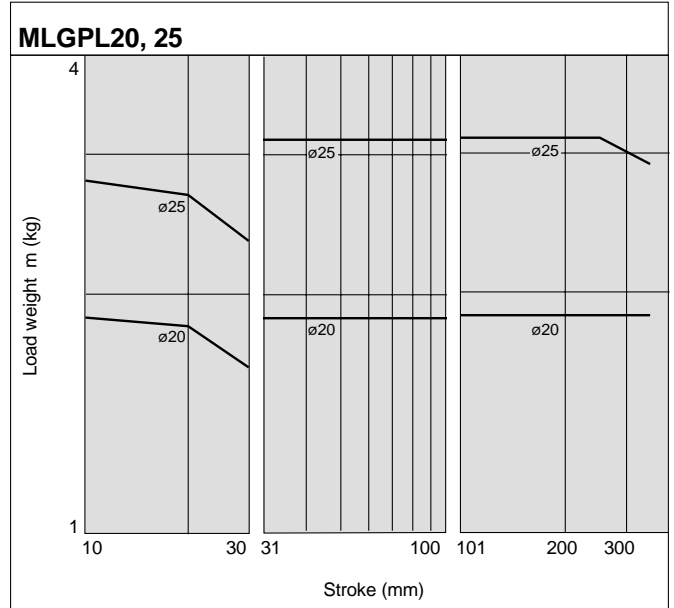

MLGPL32 to 63

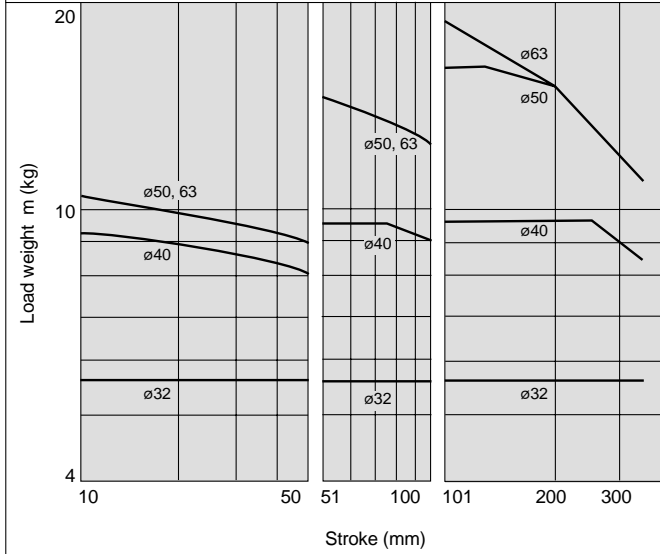

MLGPL32 to 63

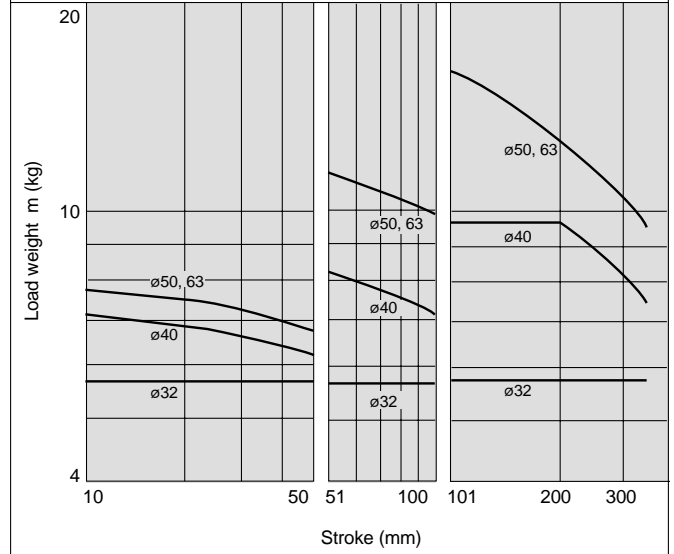

MLGPL80, 100

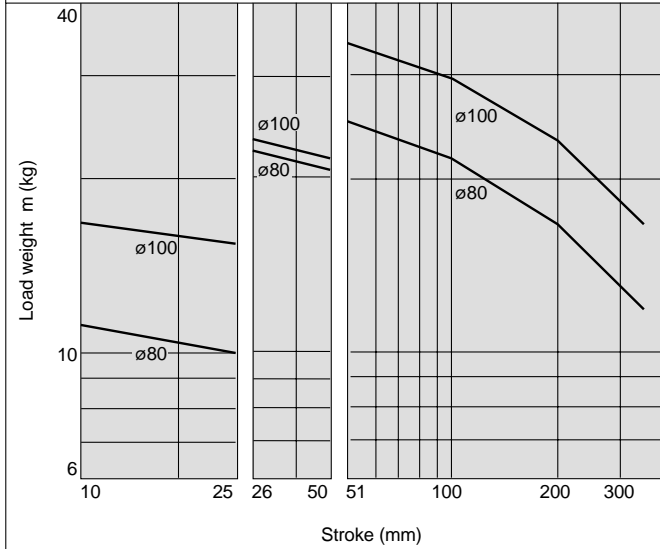

MLGPL80, 100

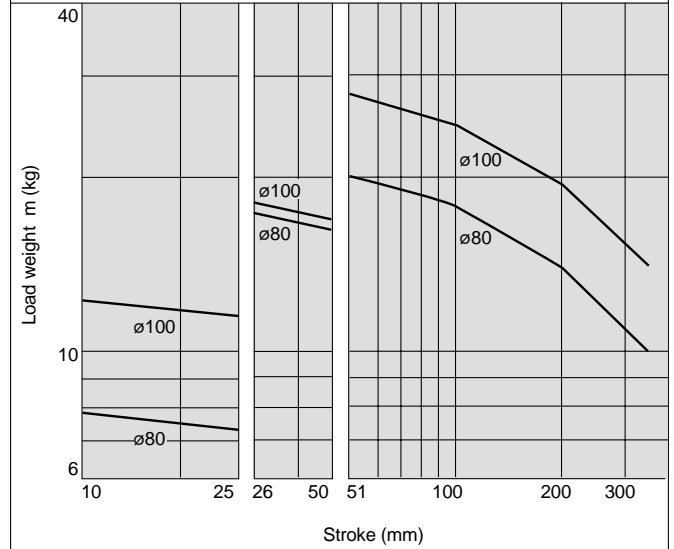

Operating Range when Used as Stopper

⚠ Warning

1. When using the cylinder as a stopper, do not allow work pieces to collide in the locked condition. If work pieces collide in the locked condition, the lock may disengage due to the shock, or the lock mechanism and piston rod may be damaged, causing a dramatic decrease of the product life and/ or further damage.
2. Model MLGPL (ball bushing) cannot be used as a stopper. When MLGPL (ball bushing) is used as a stopper, the impact will cause damage to the bearing unit and guide rod.

⚠ Caution

1. When using as a stopper, select a model with a stroke of 30mm or less for bore sizes $\phi 20$ and $\phi 25$, and 50mm or less for bore sizes $\phi 32$ to $\phi 100$.
2. When selecting a model with a longer l /dimension, be sure to choose a bore size which is sufficiently large.

Bore Sizes $\phi 20$ and $\phi 25$ /MLGPM20, 25 (Slide bearing)

Operating range as stopper for MLGPM20, 25

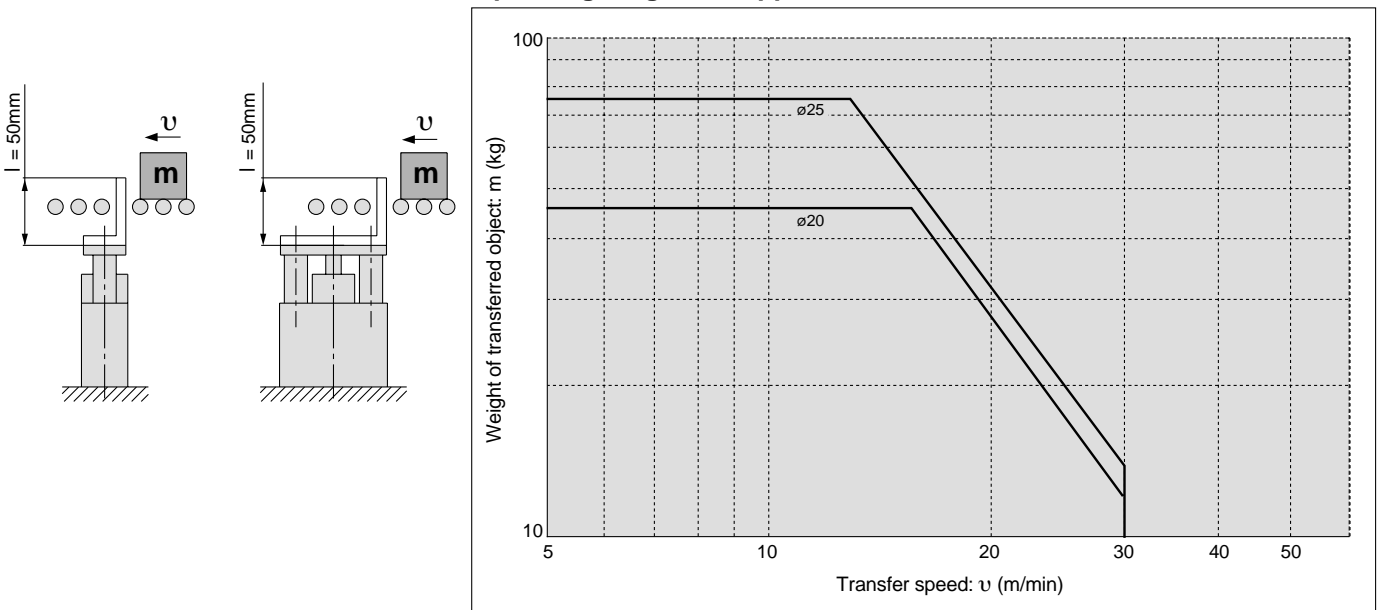

Bore Sizes $\phi 32$ to $\phi 100$ /MLGPM32 to 100 (Slide bearing)

Operating range as stopper for MLGPM32 to 100

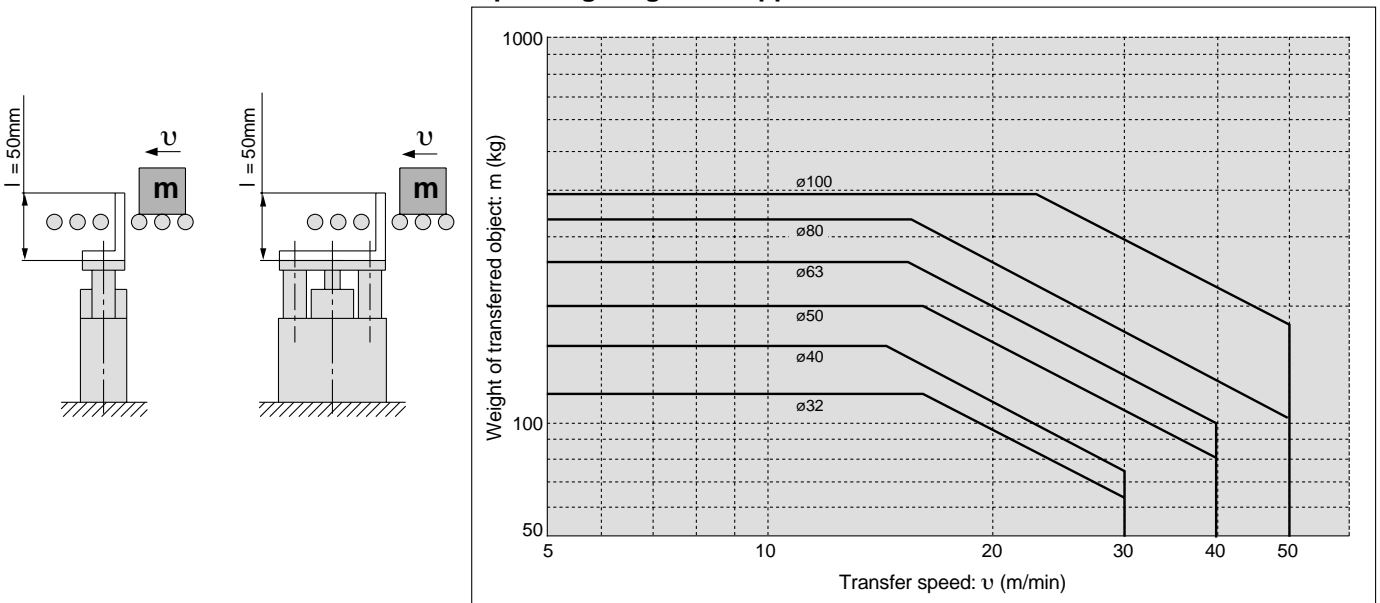

Low Profile Guide Cylinder with Lock

Series *MLGP*

∅20, ∅25, ∅32, ∅40, ∅50, ∅63, ∅80, ∅100

How to Order

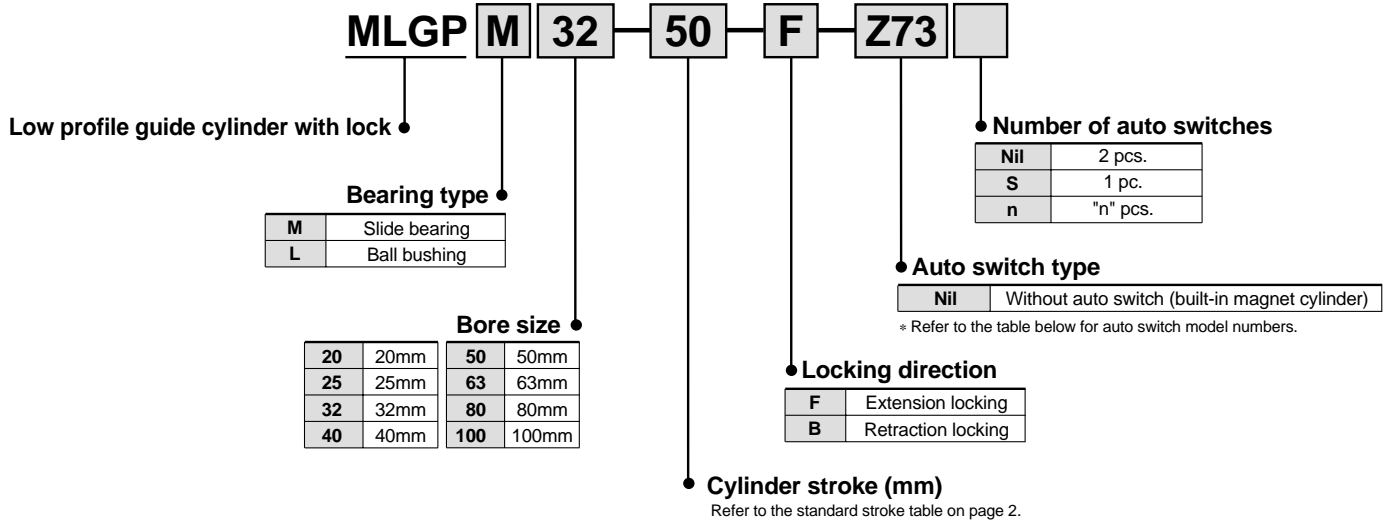

Applicable auto switches

Type	Special function	Electrical entry	Indicator light	Wiring (output)	Load voltage		Auto switch model		Lead wire length (m) ^{Note 1)}			Applicable load		Detailed specifications	
					DC	AC	Electrical entry direction		0.5 (Nil)	3 (L)	5 (Z)	IC circuit	Relay, PLC		
						Perpendicular	In-line								
Reed switch	—	Grommet	Yes	3 wire	—	5V	—	—	Z76	●	●	—	IC circuit	Relay, PLC	P. 12
				2 wire	24V	12V	100V	—	Z73	●	●	●	—		
			No	5V 12V	100V or less	—	Z80	●	●	—	IC circuit				
Solid state switch	—	Grommet	Yes	3 wire (NPN)	24V	5V 12V	—	Y69A	Y59A	●	●	○	IC circuit	Relay, PLC	P. 13
				3 wire (PNP)				Y7PV	Y7P	●	●	○			
				2 wire				Y69B	Y59B	●	●	○	—		
				3 wire (NPN)				Y7NWV	Y7NW	●	●	○	IC circuit		
	3 wire (PNP)			Y7PWV				Y7PW	●	●	○	—	P. 14		
	2 wire			Y7BWV				Y7BW	●	●	○	—	P. 15		
	—			—				Y7BA	—	●	○	—	P. 16		
Water resistant (2 color indicator)	—	—	—	—	—	—	—	—	—	—	—	—	—	—	
Magnetic field resistant (2 color indicator)	—	—	—	—	—	—	—	—	—	—	—	—	—	—	
									^{Note 3)} P5DW	—	●	●	—	—	P. 16

Note 1) Lead wire symbols 0.5m Nil (Example) Y69B
 3m L Y69BL
 5m Z Y69BZ

Note 2) Solid state auto switches marked with a "○" are produced upon receipt of order.

Note 3) Type D-P5DW cannot be mounted on bore sizes of ∅32 or less.

Cylinder Specifications



Action	Double acting
Fluid	Air
Proof pressure	1.5MPa
Maximum operating pressure	1.0MPa
Minimum operating pressure	0.2MPa ^{Note)}
Ambient and fluid temperature	-10 to 60°C (with no freezing)
Piston speed	50 to 400mm/s
Cushion	Rubber bumper at both ends
Lubrication	Non-lube
Stroke length tolerance	$^{+1.5}_0$ mm

Note) When the unlocking air and cylinder operating air are not common, the minimum operating pressure is 0.15MPa. (The minimum operating pressure for the cylinder alone is 0.15MPa.)

Lock Specifications

Bore size (mm)	20	25	32	40	50	63	80	100
Locking action	Spring locking (exhaust locking)							
Unlocking pressure	0.2MPa or more							
Locking pressure	0.05MPa or less							
Locking direction	One direction (extension locking, retraction locking)							
Maximum operating pressure	1.0MPa							
Unlocking port size	M5 x 0.8			Rc 1/8				Rc 1/4
Holding force (maximum static load) N	157	245	402	629	982	1559	2513	3927

Standard Strokes

Bore size (mm)	Standard stroke (mm)
20, 25	20, 30, 40, 50, 75, 100, 125, 150, 175, 200, 250, 300, 350
32 to 80	25, 50, 75, 100, 125, 150, 175, 200, 250, 300, 350
100	50, 75, 100, 125, 150, 175, 200, 250, 300, 350

Manufacture of Intermediate Strokes

Modification method	Spacers installed Spacers are installed in standard stroke cylinders. ø20 to 32: Stroke can be modified in 1mm increments. ø40 to 100: Stroke can be modified in 5mm increments.						
Part number	Refer to standard part numbers and ordering.						
Applicable stroke (mm)	<table border="1"> <tr> <td>ø20, ø25, ø32</td> <td>1 to 349</td> </tr> <tr> <td>ø40 to ø80</td> <td>5 to 345</td> </tr> <tr> <td>ø100</td> <td>25 to 345</td> </tr> </table>	ø20, ø25, ø32	1 to 349	ø40 to ø80	5 to 345	ø100	25 to 345
ø20, ø25, ø32	1 to 349						
ø40 to ø80	5 to 345						
ø100	25 to 345						
Example	Part no.: MLGPM20-39-F A 1mm spacer is installed in MLGPM20-40-F . Dimension C is 77mm.						

Theoretical Output



Bore size (mm)	Rod size (mm)	Operating direction	Piston area (mm ²)	Operating pressure (MPa)								
				0.2	0.3	0.4	0.5	0.6	0.7	0.8	0.9	1.0
20	10	OUT	314	63	94	126	157	188	220	251	283	314
		IN	236	47	71	94	118	142	165	189	212	236
25	12	OUT	491	98	147	196	246	295	344	393	442	491
		IN	378	76	113	151	189	227	265	302	340	378
32	16	OUT	804	161	241	322	402	482	563	643	724	804
		IN	603	121	181	241	302	362	422	482	543	603
40	16	OUT	1257	251	377	503	629	754	880	1006	1131	1257
		IN	1056	211	317	422	528	634	739	845	950	1056
50	20	OUT	1963	393	589	785	982	1178	1374	1570	1767	1963
		IN	1649	330	495	660	825	990	1154	1319	1484	1649
63	20	OUT	3117	623	935	1247	1559	1870	2182	2494	2805	3117
		IN	2803	561	841	1121	1402	1682	1962	2242	2523	2803
80	25	OUT	5027	1005	1508	2011	2514	3016	3519	4022	4524	5027
		IN	4536	907	1361	1814	2268	2722	3175	3629	4082	4536
100	30	OUT	7854	1571	2356	3142	3927	4712	5498	6283	7069	7854
		IN	7147	1429	2144	2859	3574	4288	5003	5718	6432	7147

Note) Theoretical output (N) = Pressure (MPa) x Piston area (mm²)

Symbols

Extension locking

Retraction locking

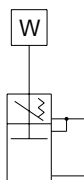
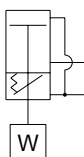

Minimum Auto Switch Mounting Stroke (mm)

Number of auto switches	D-Z7□ D-Z80 D-Y59□ D-Y7P D-Y7□W	D-Y69□ D-Y7PV	D-Y7□WV	D-Y7BAL	D-P5DWL
1 pc.	15	5	10	20	25
2 pcs.	15	5	15	20	25

Note) Model D-P5DW can only be mounted with bore sizes ø40 to ø100.

Auto switch mounting bracket part number for D-P5DW

Bore size (mm)	Mounting bracket part no.	Notes
40, 50, 63, 80, 100	BMG1-040	Switch mounting bracket Hexagon socket head cap screw (M2.5 x 0.45 x 8 / 2 pcs. Hexagon socket head cap screw (M3 x 0.5 x 16 / 2 pcs. Spring washer (nominal size 3)

Series **MLGP**

Weights

Slide bearing: MLGPM20 to 100

Bore size (mm)	Standard stroke (mm)													
	20	25	30	40	50	75	100	125	150	175	200	250	300	350
20	0.84	—	0.92	1.00	1.08	1.34	1.54	1.74	1.93	2.13	2.33	2.80	3.20	3.59
25	1.22	—	1.32	1.43	1.54	1.92	2.19	2.46	2.74	3.01	3.28	3.94	4.48	5.03
32	—	2.09	—	—	2.47	2.87	3.25	3.64	4.02	4.40	4.78	5.73	6.49	7.26
40	—	2.44	—	—	2.86	3.32	3.74	4.17	4.59	5.02	5.44	6.48	7.34	8.19
50	—	4.13	—	—	4.77	5.50	6.14	6.78	7.42	8.06	8.70	10.4	11.6	12.9
63	—	5.23	—	—	5.99	6.83	7.59	8.34	9.10	9.85	10.7	12.5	14.0	15.5
80	—	8.50	—	—	9.44	10.7	11.7	12.6	13.6	14.5	15.5	17.9	19.8	21.6
100	—	—	—	—	15.3	17.0	18.3	19.7	21.0	22.3	23.6	27.0	29.6	32.3

Ball bushing: MLGPL20 to 100

Bore size (mm)	Standard stroke (mm)													
	20	25	30	40	50	75	100	125	150	175	200	250	300	350
20	0.86	—	0.93	1.05	1.13	1.30	1.47	1.68	1.85	2.03	2.20	2.58	2.93	3.28
25	1.22	—	1.31	1.49	1.58	1.81	2.05	2.32	2.55	2.78	3.01	3.51	3.98	4.44
32	—	1.89	—	—	2.20	2.65	2.97	3.34	3.66	3.97	4.29	4.98	5.61	6.24
40	—	2.16	—	—	2.58	3.07	3.43	3.85	4.21	4.57	4.93	5.71	6.43	7.15
50	—	3.69	—	—	4.33	5.08	5.63	6.27	6.82	7.37	7.92	9.15	10.3	11.4
63	—	4.77	—	—	5.53	6.40	7.06	7.82	8.48	9.15	9.81	11.3	12.7	14.0
80	—	8.11	—	—	9.25	10.6	11.4	12.2	13.0	13.9	14.7	16.6	18.2	19.9
100	—	—	—	—	14.7	16.5	17.6	18.8	20.0	21.2	22.4	25.0	27.3	29.7

Allowable Rotational Torque of Plate

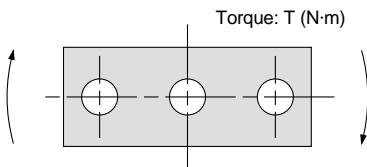

Bore size (mm)	Bearing type	Stroke (mm)													
		20	25	30	40	50	75	100	125	150	175	200	250	300	350
20	MLGPM	0.77	—	0.70	0.64	0.59	1.62	1.42	1.27	1.15	1.05	0.97	0.83	0.73	0.65
	MLGPL	0.75	—	0.68	1.49	1.41	1.24	1.11	1.29	1.18	1.08	1.00	0.86	0.76	0.67
25	MLGPM	1.24	—	1.13	1.04	0.97	2.49	2.20	1.98	1.79	1.64	1.51	1.30	1.15	1.02
	MLGPL	1.23	—	1.14	2.26	2.14	1.90	1.71	1.96	1.79	1.65	1.53	1.33	1.17	1.04
32	MLGPM	—	4.89	—	—	4.13	4.82	4.29	3.87	3.53	3.24	2.99	2.60	2.30	2.06
	MLGPL	—	4.22	—	—	3.64	4.07	3.67	5.37	4.97	4.62	4.31	3.80	3.39	3.06
40	MLGPM	—	5.29	—	—	4.49	5.25	4.68	4.23	3.86	3.54	3.28	2.85	2.52	2.26
	MLGPL	—	4.53	—	—	3.93	4.41	3.98	5.84	5.41	5.03	4.70	4.15	3.70	3.34
50	MLGPM	—	10.06	—	—	8.66	10.13	9.12	8.29	7.60	7.01	6.51	5.70	5.06	4.56
	MLGPL	—	6.40	—	—	5.57	7.76	7.04	9.75	9.05	8.43	7.88	6.96	6.22	5.60
63	MLGPM	—	11.13	—	—	9.60	11.27	10.15	9.24	8.48	7.83	7.28	6.37	5.67	5.11
	MLGPL	—	6.91	—	—	6.02	8.48	7.69	10.73	9.95	9.27	8.67	7.65	6.83	6.14
80	MLGPM	—	16.70	—	—	14.67	19.10	17.41	15.99	14.79	13.75	12.85	11.36	10.18	9.23
	MLGPL	—	9.44	—	—	16.88	17.92	16.51	15.28	14.20	13.24	12.37	10.89	9.66	8.62
100	MLGPM	—	—	—	—	26.17	30.70	28.23	26.12	24.31	22.73	21.35	19.03	17.17	15.64
	MLGPL	—	—	—	—	21.11	29.10	26.98	25.10	23.43	21.93	20.57	18.21	16.22	14.53

Note) Do not apply rotational force in a locked condition, as this will cause damage to the lock mechanism or decrease of the product life.

Non-rotating Accuracy of Plate

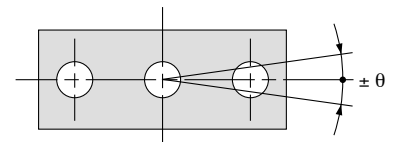

Note) For non-rotating accuracy θ without load, use a value no more than the values in the table as a guide.

Bore size (mm)	Non-rotating accuracy θ	
	MLGPM	MLGPL
20	$\pm 0.07^\circ$	$\pm 0.09^\circ$
25	$\pm 0.07^\circ$	$\pm 0.09^\circ$
32	$\pm 0.06^\circ$	$\pm 0.08^\circ$
40	$\pm 0.06^\circ$	$\pm 0.08^\circ$
50	$\pm 0.05^\circ$	$\pm 0.06^\circ$
63	$\pm 0.05^\circ$	$\pm 0.06^\circ$
80	$\pm 0.04^\circ$	$\pm 0.05^\circ$
100	$\pm 0.04^\circ$	$\pm 0.05^\circ$

Construction/ø20, ø25, ø32

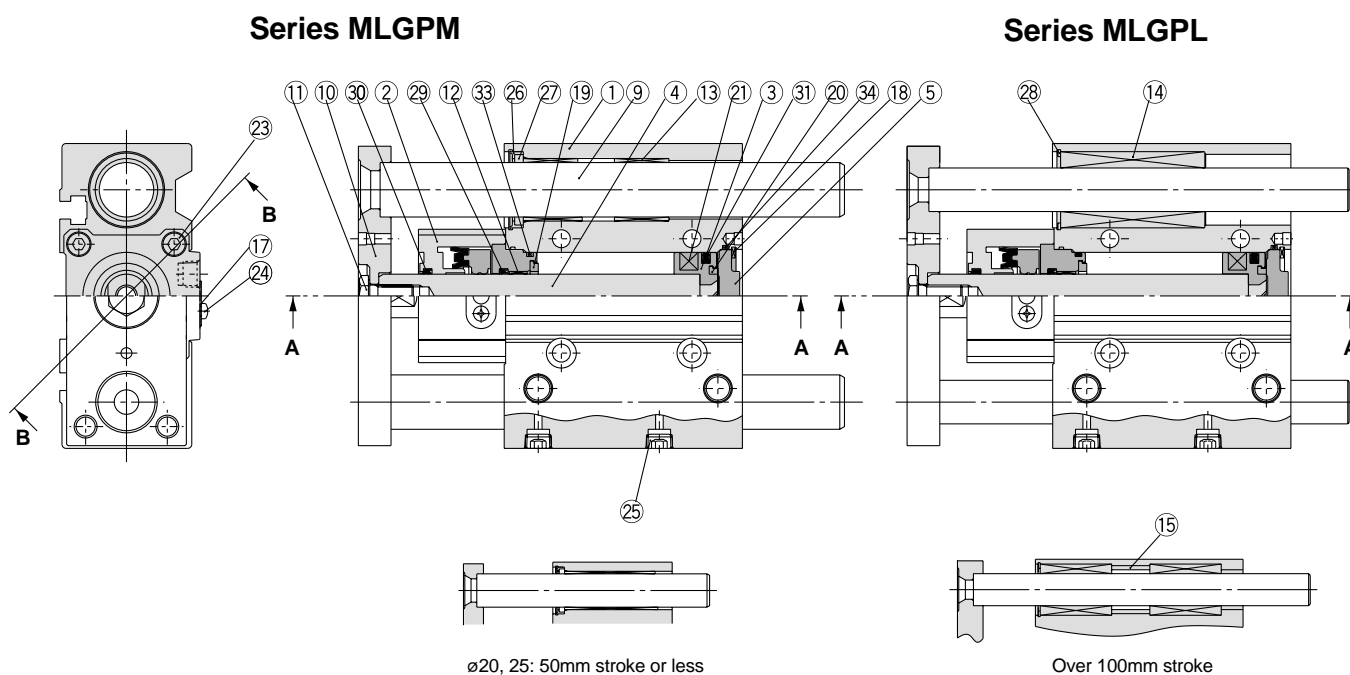

Extension locking (Type F)

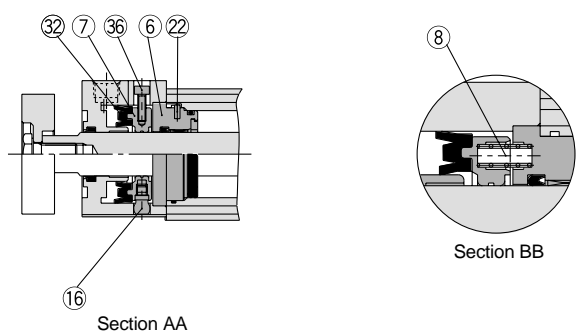

Retraction locking (Type B)

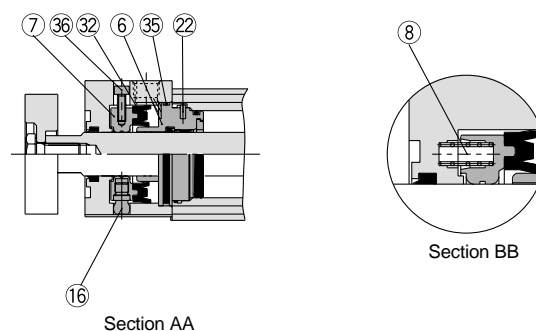

Parts list

No.	Description	Material	Note
1	Body	Aluminum alloy	Hard anodized
2	Lock body	Aluminum alloy	Hard anodized
3	Piston	Aluminum alloy	Chromated
4	Piston rod	ø20, 25	Hard chrome plated
		ø32	
5	Head cover	Aluminum alloy	Coated
6	Intermediate collar	Type F	Chromated
		Type B	Hard anodized
7	Lock ring	Carbon steel	Heat treated
8	Brake spring	Steel wire	Zinc chromated
9	Guide rod	Type M	Hard chrome plated
		Type L	High carbon chromium bearing steel
10	Plate	Rolled steel	Nickel plated
11	Plate mounting bolt	Chrome molybdenum steel	Nickel plated
12	Bushing	ø20, 25	Oil-impregnated sintered alloy
		ø32	Lead bronze casting
13	Slide bearing	Lead bronze casting	
14	Ball busing	—	
15	Spacer	Aluminum alloy	Chromated
16	Pivot	Chrome molybdenum steel	Heat treated/Electroless nickel plated

Parts list

No.	Description	Material	Note
17	Dust cover	Stainless steel	
18	C type snap ring for hole	Carbon tool steel	Phosphate coated
19	Bumper A	Urethane	
20	Bumper B	Urethane	
21	Plastic magnet	—	
22	Parallel pin	Carbon steel	
23	Hexagon socket head cap screw	Chrome molybdenum steel	Nickel plated
24	Dust cover holding bolt	Carbon steel	Nickel plated
25	Hexagon socket head taper screw plug	Carbon steel	Nickel plated
26	Holder	Resin	
27	Felt	Felt	
28	C type snap ring for hole	Carbon tool steel	Phosphate coated
29	Rod seal	NBR	
30	Scraper	NBR	
31	Piston seal	NBR	
32	Lock ring seal	NBR	
33	Gasket A	NBR	
34	Gasket B	NBR	
35	Lock body gasket	NBR	
36	Unlocking bolt	Chrome molybdenum steel	Nickel plated

Series MLGP

Construction/ø40 to ø100

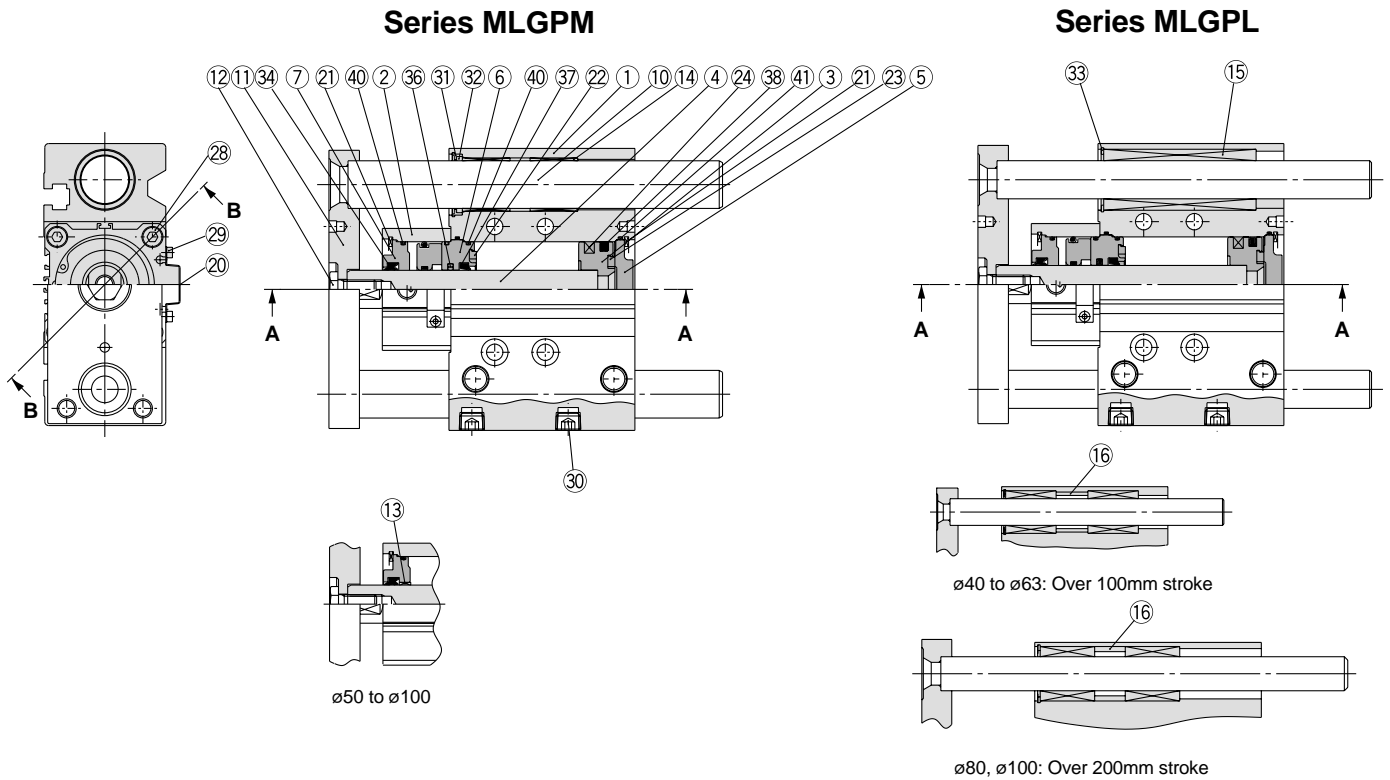

Extension locking (Type F)

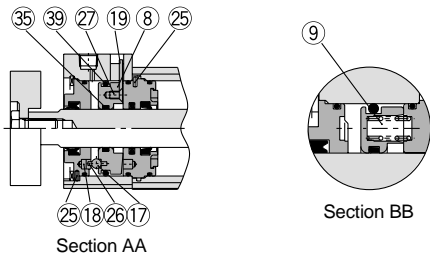

Retraction locking (Type B)

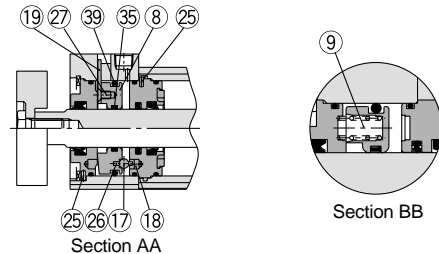

Parts list

No.	Description	Material	Note	
1	Body	Aluminum alloy	Hard anodized	
2	Lock body	Aluminum alloy	Hard anodized	
3	Piston	Aluminum alloy	Chromated	
4	Piston rod	Carbon steel	Hard chrome plated	
5	Head cover	ø40 to 63	Aluminum alloy	Coated
		ø80, 100	Aluminum alloy casting	Chromated/Coated
6	Intermediate collar	Aluminum alloy	Chromated	
7	Collar	ø40	Aluminum alloy	Hard anodized
		ø50 to 100	Aluminum alloy casting	Chromated/Coated
8	Lock ring	Carbon steel	Heat treated	
9	Brake spring	Steel wire	Zinc chromated	
10	Guide rod	Type M	Carbon steel	Hard chrome plated
		Type L	High carbon chromium bearing steel	Heat treated/Hard chrome plated
11	Plate	Rolled steel	Nickel plated	
12	Plate mounting bolt	Chrome molybdenum steel	Nickel plated	
13	Bushing	Lead bronze casting	ø50 to 100	
14	Slide bearing	Lead bronze casting		
15	Ball busing	—		
16	Spacer	Aluminum alloy	Chromated	
17	Pivot pin	Carbon steel	Heat treated/Zinc chromated	
18	Pivot key	Carbon steel	Heat treated/Zinc chromated	
19	Lever	Stainless steel		
20	Dust cover	ø40 to 63	Rolled steel	Nickel plated
		ø80, 100	Stainless steel	

Parts list

No.	Description	Material	Note	
21	C type snap ring for hole	Carbon tool steel	Phosphate coated	
22	Bumper A	Urethane		
23	Bumper B	Urethane		
24	Plastic magnet	—		
25	Parallel pin	Carbon steel		
26	Spring pin	Carbon steel		
27	Hexagon socket countersunk head screw	Chrome molybdenum steel	Nickel plated	
28	Hexagon socket head cap screw	Chrome molybdenum steel	Nickel plated	
29	Dust cover holding bolt	ø40 to 63	Chrome molybdenum steel	Nickel plated
		ø80, 100	Carbon steel	Nickel plated
30	Hexagon socket head taper screw plug	Carbon steel	Nickel plated	
31	Holder	Resin		
32	Felt	Felt		
33	C type snap ring for hole	Carbon tool steel	Phosphate coated	
34	Rod seal A	NBR		
35	Rod seal B	NBR		
36	Rod seal C	NBR		
37	Scraper	NBR		
38	Piston seal	NBR		
39	Brake piston seal	NBR		
40	Gasket A	NBR		
41	Gasket B	NBR		

Dimensions/ø20, ø25, ø32

MLGPM, MLGPL

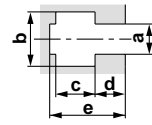
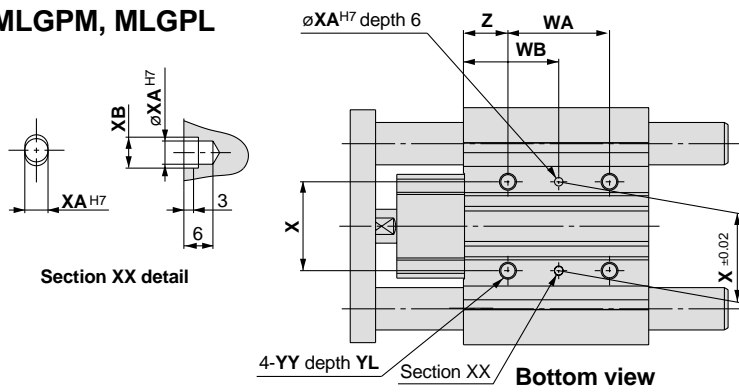

T-slot dimensions

Bore size (mm)	a	b	c	d	e
20	5.4	8.4	4.5	2.8	7.8
25	5.4	8.4	4.5	3	8.2
32	6.5	10.5	5.5	3.5	9.5

Extension locking



Retraction locking

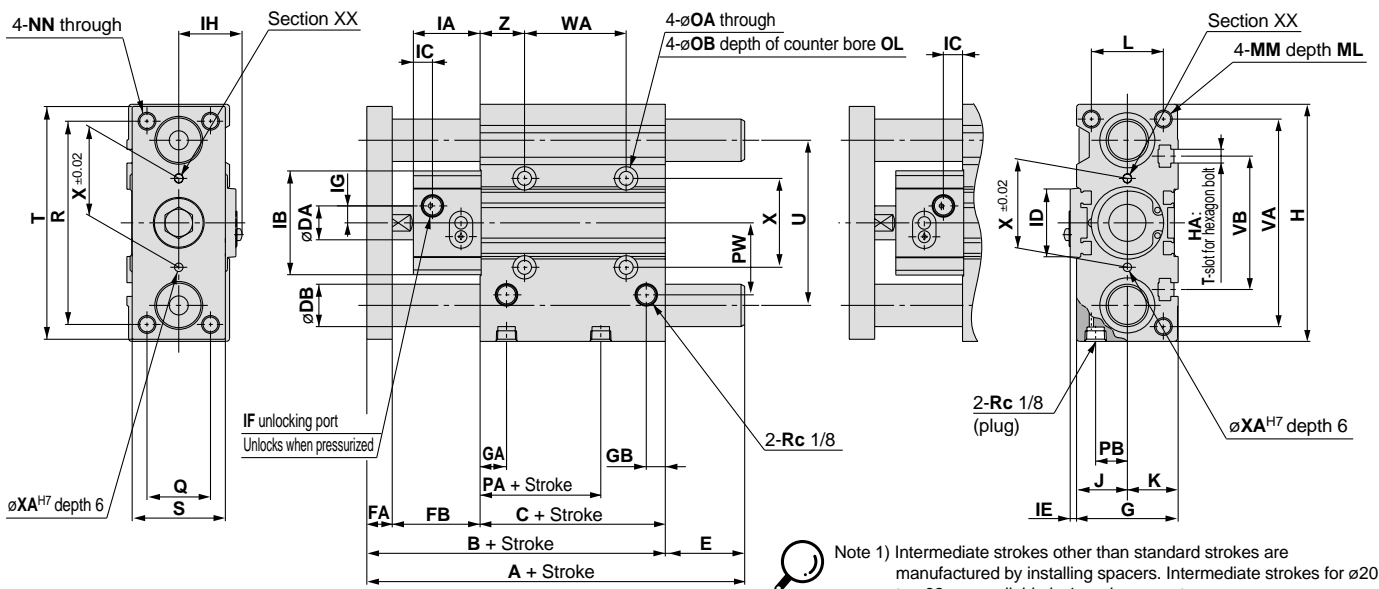

Note 1) Intermediate strokes other than standard strokes are manufactured by installing spacers. Intermediate strokes for ø20 to ø32 are available in 1mm increments.
 Note 2) For intermediate strokes, dimensions A, B, C, E, WA, and WB will be the same as the longer of the standard strokes.

MLGPM, MLGPL common dimensions

Bore size (mm)	Standard stroke (mm)																IC		ID	IE	IF	IG	IH	J	K	L
	B	C	DA	FA	FB	G	GA	GB	H	HA	IA	IB	Extension locking	Retraction locking												
20	20, 30, 40, 50, 75, 100, 125	79.5	37	10	10	32.5	36	10.5	8.5	83	M5	26.5	36	9.5	6	—	—	M5 x 0.8	6.5	21.2	18	18	24			
25	150, 175, 200, 250, 300, 350	84	37.5	12	10	36.5	42	11.5	9	93	M5	30.5	40	10	7.5	—	—	M5 x 0.8	7	23.2	21	21	30			
32	25, 50, 75, 100, 125, 150, 175, 200, 250, 300, 350	91	37.5	16	12	41.5	48	12.5	9	112	M6	31.5	49	9	9	32	3	Rc 1/8	8	30.2	24	24	34			

Bore size (mm)	MM	ML	NN	OA	OB	OL	PA	PB	PW	Q	R	S	T	U	VA	VB	WA						
																	st<25	st<30	25<st<100	30<st<100	100<st<200	200<st<300	300<st<350
20	M5 x 0.8	13	M5 x 0.8	5.6	9.5	5.5	12.5	10.5	25	18	70	30	81	54	72	44	—	24	—	44	120	200	300
25	M6 x 1.0	15	M6 x 1.0	5.6	9.5	5.5	12.5	13.5	28.5	26	78	38	91	64	82	50	—	24	—	44	120	200	300
32	M8 x 1.25	20	M8 x 1.25	6.6	11	7.5	7	15	34	30	96	44	110	78	98	63	24	—	48	—	124	200	300

Bore size (mm)	WB							X	XA	XB	YY	YL	Z
	st<25	st<30	25<st<100	30<st<100	100<st<200	200<st<300	300<st<350						
20	—	29	—	39	77	117	167	28	3	3.5	M6 x 1.0	12	17
25	—	29	—	39	77	117	167	34	4	4.5	M6 x 1.0	12	17
32	33	—	45	—	83	121	171	42	4	4.5	M8 x 1.25	16	21

MLGPM (slide bearing)/Dimensions A, DB, E (mm)

Bore size (mm)	A			DB	E		
	st<50	50<st<200	200<st		st<50	50<st<200	200<st
20	79.5	111	148.5	12	0	31.5	69
25	84	115.5	152.5	16	0	31.5	68.5
32	128.5	133.5	171.5	20	37.5	42.5	80.5

MLGPL (ball bushing)/Dimensions A, DB, E (mm)

Bore size (mm)	A						DB	E					
	st<30	st<50	30<st<100	50<st<100	100<st<200	200<st<350		st<30	st<50	30<st<100	50<st<100	100<st<200	200<st<350
20	89.5	—	106.5	—	130.5	148.5	10	10	—	27	—	51	69
25	100	—	116	—	135	152.5	13	16	—	32	—	51	68.5
32	—	112.5	—	129.5	149.5	171.5	16	—	21.5	—	38.5	58.5	80.5

Series MLGP

Dimensions/ø40, ø50, ø63

MLGPM, MLGPL

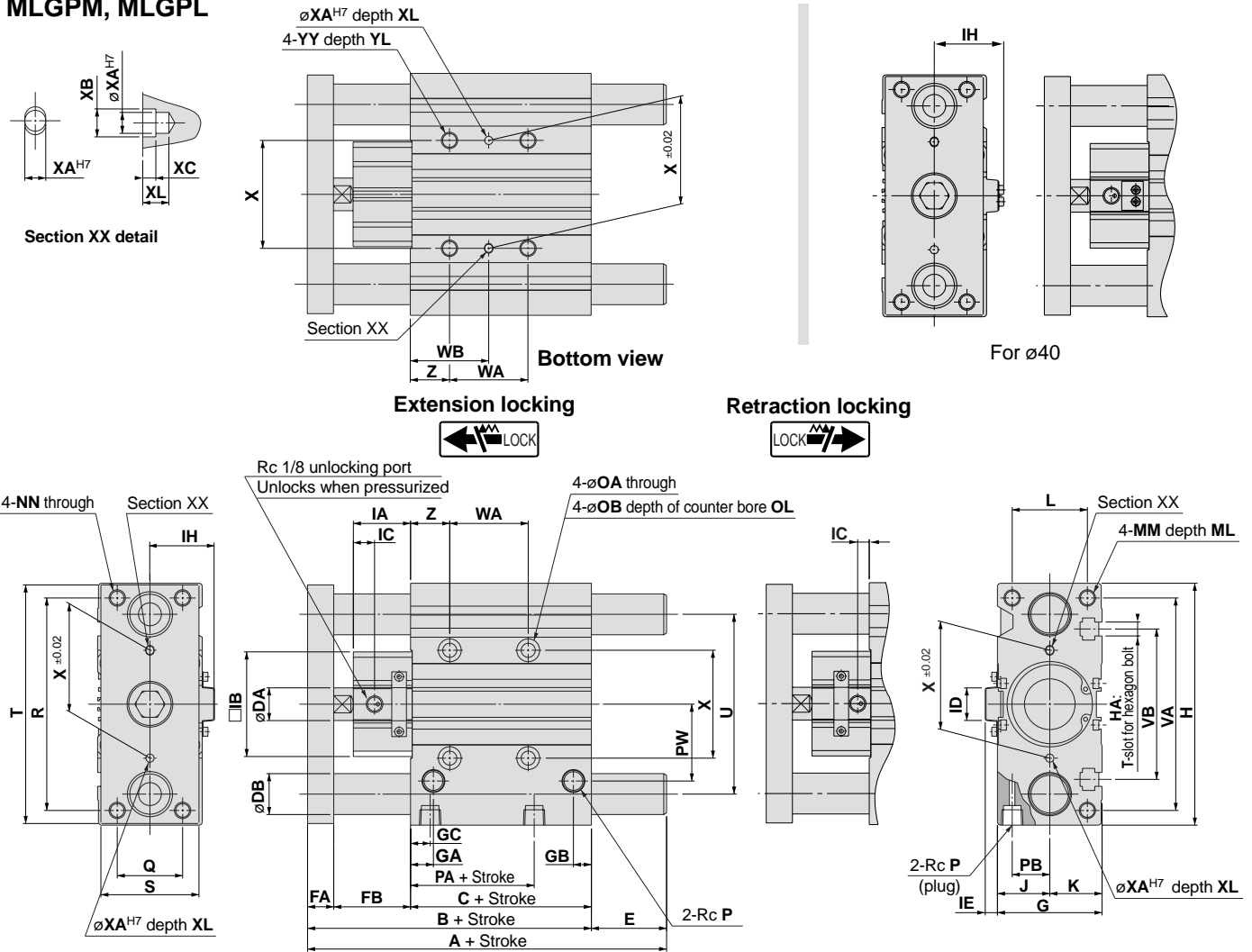

Note 1) Intermediate strokes other than standard strokes are manufactured by installing spacers. Intermediate strokes for ø40 to ø63 are available in 5mm increments.

Note 2) For intermediate strokes, dimensions A, B, C, E, WA, and WB will be the same as the longer of the standard strokes.

T-slot dimensions

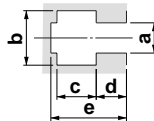

Bore size (mm)	a	b	c	d	e
40	6.5	10.5	5.5	4	11
50	8.5	13.5	7.5	4.5	13.5
63	11	17.8	10	7	18.5

MLGPM, MLGPL common dimensions

Bore size (mm)	Standard stroke (mm)	B	C	DA	FA	FB	G	GA	GB	GC	H	HA	IA	IB	IC		ID	IE	IH	J	K	L
															Extension locking	Retraction locking						
40	25, 50, 75, 100, 125, 150, 175, 200, 250, 300, 350	100	44	16	12	44	54	14	10	14	120	M6	34	52	11	6.5	14	4	34.5	27	27	40
50		107	44	20	16	47	64	14	11	12	148	M8	35	64	13	6.8	19	7	39.5	32	32	46
63		115	49	20	16	50	78	16.5	13.5	16.5	162	M10	38	77	16.5	7.5	19	6.5	46	39	39	58

Bore size (mm)	MM	ML	NN	OA	OB	OL	P	PA	PB	PW	Q	R	S	T	U	VA	VB	WA				
																		st≤25	25<st≤100	100<st≤200	200<st≤300	300<st≤350
40	M8 x 1.25	20	M8 x 1.25	6.6	11	7.5	1/8	13	18	38	30	104	44	118	86	106	72	24	48	124	200	300
50	M10 x 1.5	22	M10 x 1.5	8.6	14	9	1/4	9	21.5	47	40	130	60	146	110	130	92	24	48	124	200	300
63	M10 x 1.5	22	M10 x 1.5	8.6	14	9	1/4	14	28	55	50	130	70	158	124	142	110	28	52	128	200	300

Bore size (mm)	WB					X	XA	XB	XC	XL	YY	YL	Z
	st≤25	25<st≤100	100<st≤200	200<st≤300	300<st≤350								
40	34	46	84	122	172	50	4	4.5	3	6	M8 x 1.25	16	22
50	36	48	86	124	174	66	5	6	4	8	M10 x 1.5	20	24
63	38	50	88	124	174	80	5	6	4	8	M10 x 1.5	20	24

MLGPM (slide bearing)/Dimensions A, DB, E (mm)

Bore size (mm)	A			DB	E		
	st≤50	50<st≤200	200<st≤350		st≤50	50<st≤200	200<st≤350
40	131	136	174	20	31	36	74
50	141.5	153	196	25	34.5	46	89
63	144.5	156	199	25	29.5	41	84

MLGPL (ball bushing)/Dimensions A, DB, E (mm)

Bore size (mm)	A				DB	E			
	st≤50	50<st≤100	100<st≤200	200<st≤350		st≤50	50<st≤100	100<st≤200	200<st≤350
40	115	132	152	174	16	15	32	52	74
50	128	149	169	196	20	21	42	62	89
63	131	152	172	199	20	16	37	57	84

Dimensions/ø80, ø100

MLGPM, MLGPL

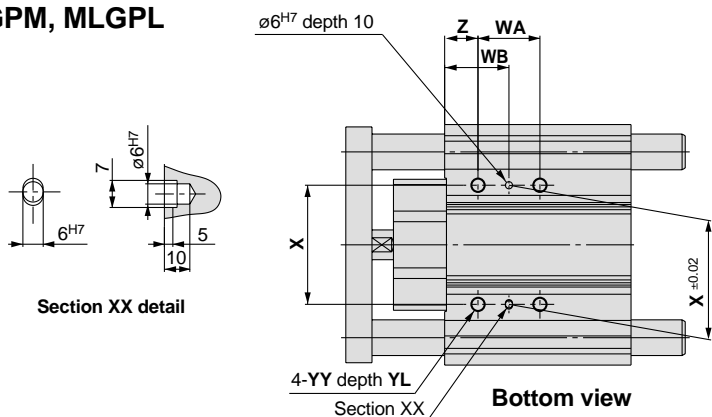

Bore size (mm)	a	b	c	d	e
80	13.3	20.3	12	8	22.5
100	15.3	23.3	13.5	10	30

Extension locking



Retraction locking

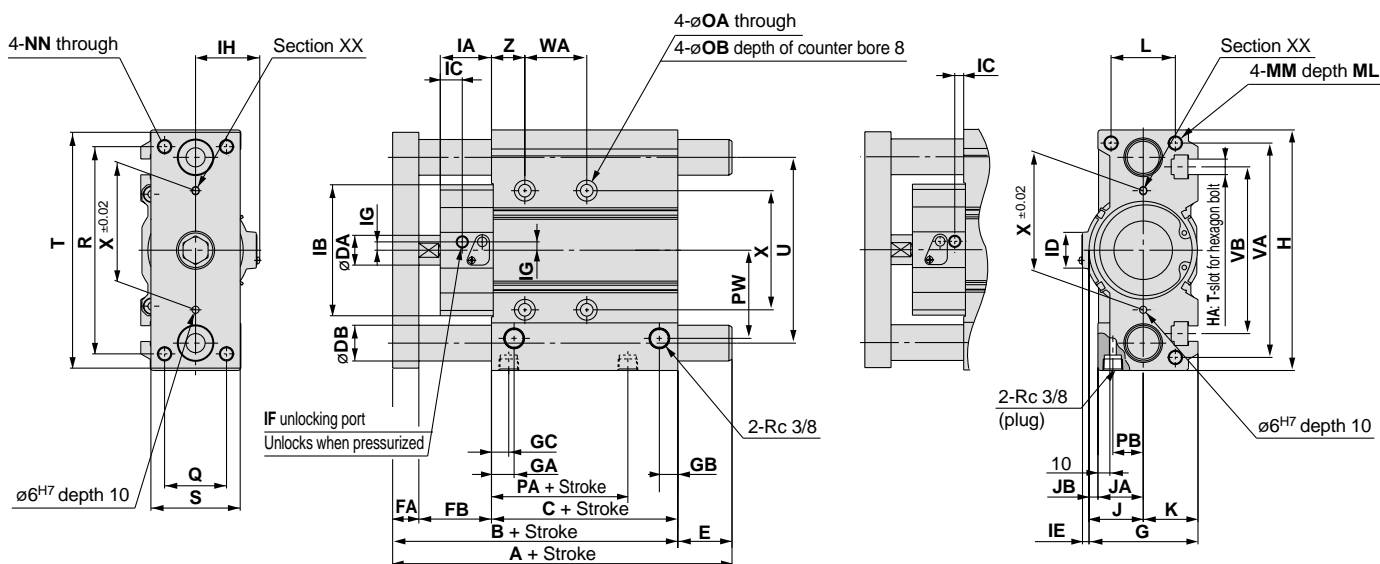

Note 1) Intermediate strokes other than standard strokes are manufactured by installing spacers. Intermediate strokes for ø80 and ø100 are available in 5mm increments.

Note 2) For intermediate strokes, dimensions A, B, C, E, WA, and WB will be the same as the longer of the standard strokes.

MLGPM, MLGPL common dimensions

Bore size (mm)	Standard stroke (mm)	B	C	DA	FA	FB	G	GA	GB	GC	H	HA	IA	IB	IC		ID	IE	IF	IG	IH	J	JA
															Extension locking	Retraction locking							
80	25, 50, 75, 100, 125, 150, 175, 200, 250, 300, 350	139.5	56.5	25	22	61	91.5	19	15.5	14.5	202	M12	43	110	18.5	7.5	30	5.5	Rc 1/8	7	54.2	45.5	38
100	50, 75, 100, 125, 150, 175, 200, 250, 300, 350	167.5	66	30	25	76.5	111.5	23	19	18	240	M14	51.5	137	23	11	50	5.5	Rc 1/4	15	64.2	55.5	45

Bore size (mm)	JB	K	L	MM	ML	NN	OA	OB	PA	PB	PW	Q	R	S	T	U	VA	VB	WA						
																			st≤25	st≤50	25<st≤100	50<st≤100	100<st≤200	200<st≤300	300<st≤350
80	7.5	46	54	M12 x 1.75	25	M12 x 1.75	10.6	17.5	14.5	25.5	74	52	174	75	198	156	180	140	28	—	52	—	128	200	300
100	10.5	56	62	M14 x 2.0	31	M14 x 2.0	12.5	20	17.5	32.5	89	64	210	90	236	188	210	166	—	50	—	72	124	200	300

Bore size (mm)	WB				X	YY	YL	Z			
	st≤25	st≤50	25<st≤100	50<st≤100							
80	42	—	54	—	92	128	178	100	M12 x 1.75	24	28
100	—	60	—	71	97	135	185	124	M14 x 2.0	28	35

MLGPM (slide bearing)/Dimensions A, DB, E (mm)

Bore size (mm)	A			DB	E		
	st≤50	50<st≤200	200<st≤350		st≤50	50<st≤200	200<st≤350
80	158	185	236	30	18.5	45.5	96.5
100	188.5	213.5	254.5	36	21	46	87

MLGPL (ball bushing)/Dimensions A, DB, E (mm)

Bore size (mm)	A				DB	E			
	st≤25	25<st≤50	50<st≤200	200<st≤350		st≤25	25<st≤50	50<st≤200	200<st≤350
80	152.5	173	203	236	25	13	33.5	63.5	96.5
100	—	198.5	231.5	254.5	30	—	31	64	87

Series MLGP

Auto Switches/Proper Mounting Position for Stroke End Detection

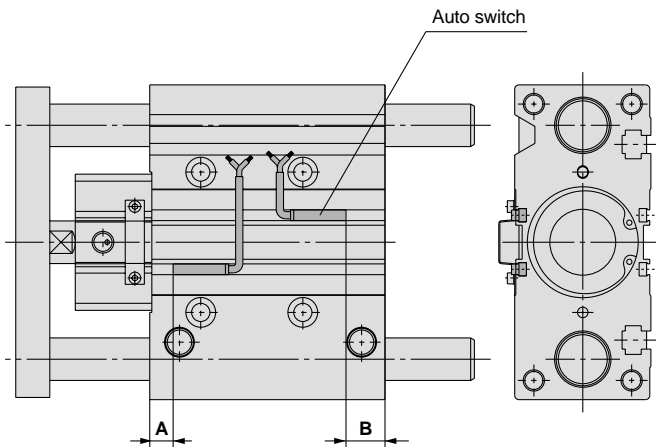

Proper mounting position (mm)

Bore size (mm)	A	B
20	4	8
25	4.5	8
32	5.5	7
40	9.5 (9)	9.5 (9)

Bore size (mm)	A	B
50	7.5 (7)	11.5 (11)
63	10 (9.5)	14 (13.5)
80	13 (12.5)	18.5 (18)
100	17.5 (17)	23.5 (23)

Note 1) Values inside () are for D-P5DW, which can only be mounted on bores sizes $\phi 40$ through $\phi 100$.

For D-P5DW (* Cannot be mounted on bore sizes $\phi 32$ or less.)

$\phi 40$ to $\phi 63$

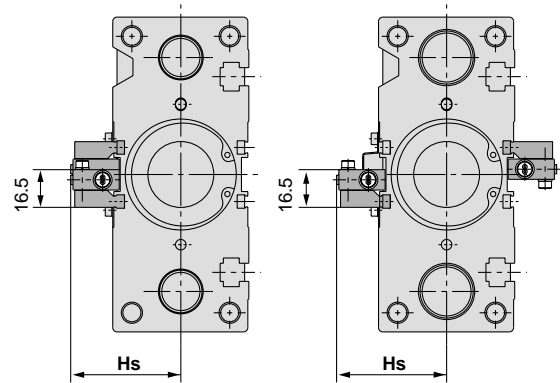

$\phi 80, \phi 100$

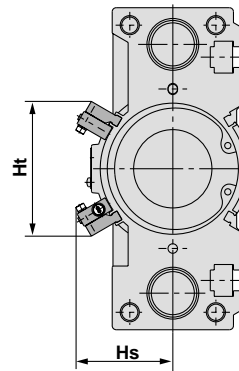

For 25mm stroke

* For bore sizes $\phi 40$ through $\phi 63$ with two switches, one switch is mounted on each side.

Bore size (mm)	Hs	Ht
40	44.5	—
50	50	—
63	57	—
80	60.7	84.4
100	70.8	96.1

Auto Switch Mounting

⚠ Caution

Auto switch mounting tool

- When tightening the auto switch mounting screw (included with auto switch), use a watchmakers screw driver with a handle about 5 to 6mm in diameter.

Tightening torque

- Tighten with a torque of 0.05 to 0.1N·m. As a rule, it should be turned about 90° past the point at which tightening can be felt.

Inserting direction for mounting

- Auto switches can only be inserted from the rear side.

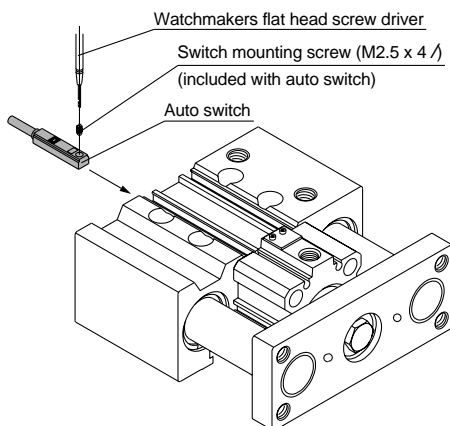

For D-P5DW

⚠ Caution

Auto switch mounting tool

- When tightening the hexagon socket head cap screws of the auto switch, use hexagon wrench key 2 and 2.5 with the appropriate screws.

Tightening torque

- Tighten M2.5 screws with a torque of about 0.3 to 0.5N·m, and M3 screws with a torque of about 0.5 to 0.7 N·m.

Inserting direction for mounting

- Auto switches can only be inserted from the rear side.

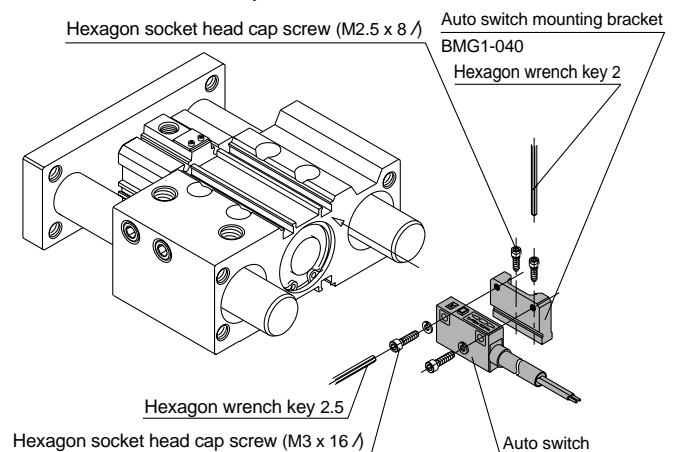

Series MLGP

Auto Switch Common Specifications

Auto Switch Common Specifications

Type	Reed switch	Solid state switch
Leakage current	None	3 wire: 100 μ A or less, 2 wire: 0.8mA or less
Operating time	1.2ms	1ms or less
Impact resistance	300m/s ²	1000m/s ²
Insulation resistance	50M Ω or more at 500VDC (between lead wire and case)	
Withstand voltage	1500VAC for 1 min. (between lead wire and case)	1000VAC for 1 min. (between lead wire and case)
Ambient temperature	-10 to 60°C	
Enclosure	IEC529 standard IP67, JISC0920 watertight construction	

Lead Wire Length

Lead wire length indication

(Example)

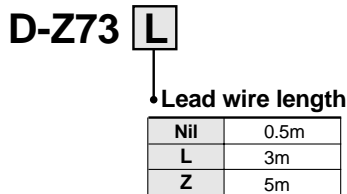

Note 1) Lead wire length Z: 5m applicable auto switch
 Reed: D-Z73
 Solid state: D-P5DW and all other types are produced upon receipt of order (standard availability).

Auto Switch Hysteresis

Hysteresis is the distance from the position at which piston movement activates an auto switch to the position at which reverse movement turns the switch OFF. This hysteresis is included in part of the operating range (one side).

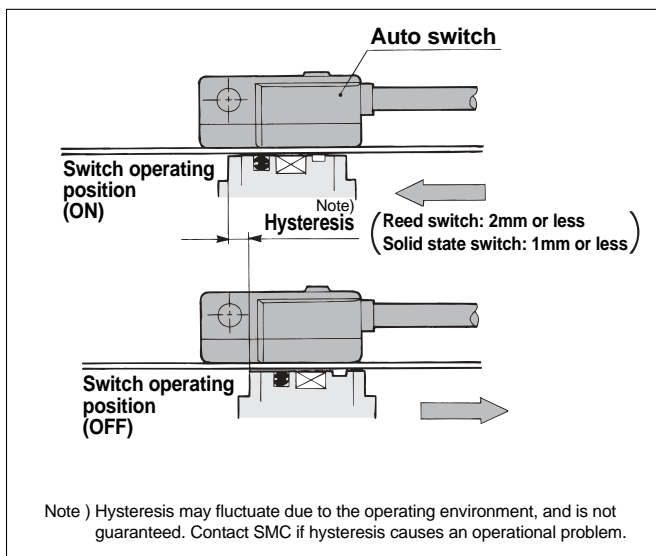

Contact Protection Boxes/CD-P11, CD-P12

D-Z7 and D-Z8 type switches do not have internal contact protection circuits.

1. The operating load is an induction load.
2. The length of wiring to the load is 5m or more.
3. The load voltage is 100VAC.

A contact protection box should be used in any of the above situations.

Contact protection box specifications

Part no.	CD-P11		CD-P12
Load voltage	100VAC or less	200VAC	24VDC
Maximum load current	25mA	12.5mA	50mA

* Lead wire length Switch connection side 0.5m
 Load connection side 0.5m



Contact protection box internal circuits

Lead wire colors inside [] are those prior to conformity with IEC standards.

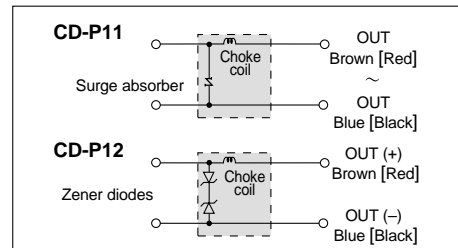

Contact protection box dimensions

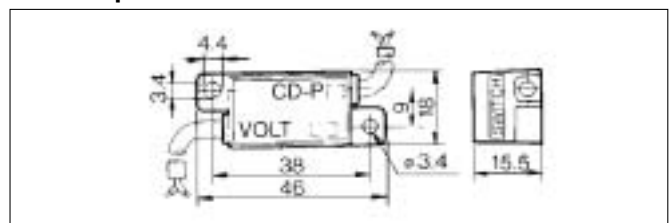

Contact Protection Box Connection

To connect a switch unit to a contact protection box, connect the lead wire from the side of the contact protection box marked SWITCH to the lead wire coming out of the switch unit.

Furthermore, the switch unit should be kept as close as possible to the contact protection box, with a lead wire length of no more than 1 meter between them.

Series MLGP Auto Switch Connections and Examples

Basic Wiring

Lead wire colors inside [] are those prior to conformity with IEC standards.

Solid state 3 wire, NPN

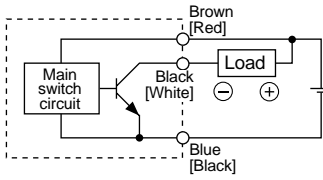

(Power supplies for switch and load are separate.)

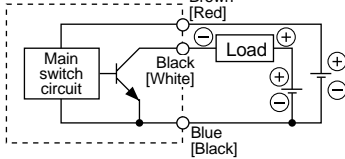

Solid state 3 wire, PNP

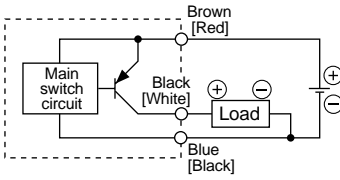

2 wire <Solid state>

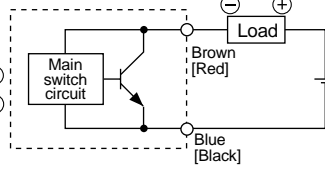

2 wire <Reed switch>

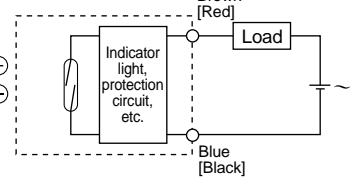

Examples of Connection to PLC

Sink input specifications

3 wire, NPN

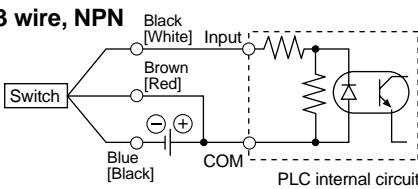

2 wire

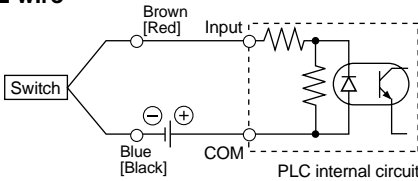

Source input specifications

3 wire, PNP

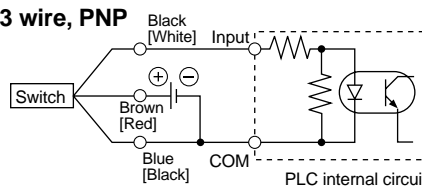

2 wire

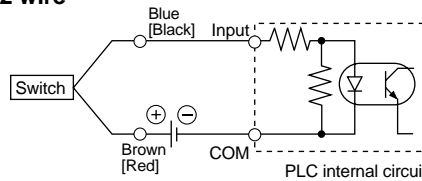

Connect according to the applicable PLC input specifications, as the connection method will vary depending on the PLC input specifications.

Connection Examples for AND (Series) and OR (Parallel)

3 wire

AND connection for NPN output (using relays)

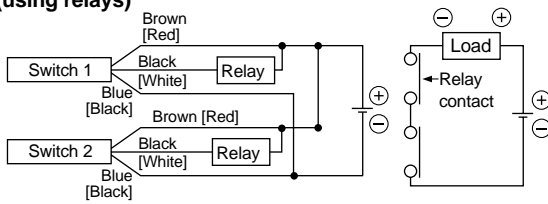

AND connection for NPN output (performed with switches only)

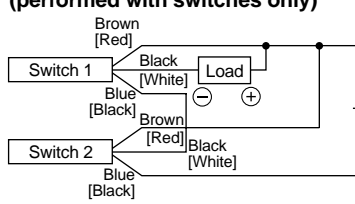

OR connection for NPN output

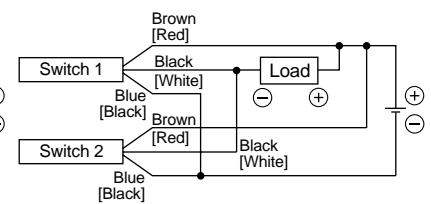

The indicator lights will light up when both switches are turned ON.

2 wire with 2 switch AND connection

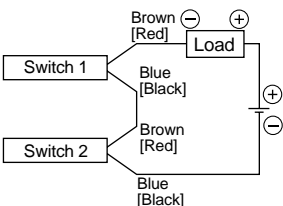

When two switches are connected in series, a load may malfunction because the load voltage will decline when in the ON state. The indicator lights will light up if both of the switches are in the ON state.

$$\begin{aligned} \text{Load voltage at ON} &= \text{Power supply voltage} - \text{Internal voltage drop} \times 2 \text{ pcs.} \\ &= 24\text{V} - 4\text{V} \times 2 \text{ pcs.} \\ &= 16\text{V} \end{aligned}$$

Example: Power supply is 24VDC
Internal voltage drop in switch is 4V

2 wire with 2 switch OR connection

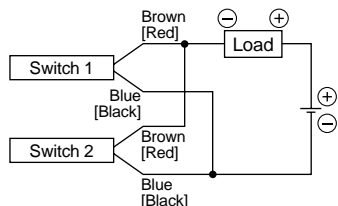

<Solid state>

When two switches are connected in parallel, malfunction may occur because the load voltage will increase when in the OFF state.

<Reed switch>

Because there is no current leakage, the load voltage will not increase when turned OFF. However, depending on the number of switches in the ON state, the indicator lights may sometimes dim or not light up, because of dispersion and reduction of the current flowing to the switches.

$$\begin{aligned} \text{Load voltage at OFF} &= \text{Leakage current} \times 2 \text{ pcs.} \times \text{Load impedance} \\ &= 1\text{mA} \times 2 \text{ pcs.} \times 3\text{k}\Omega \\ &= 6\text{V} \end{aligned}$$

Example: Load impedance is 3kΩ
Leakage current from switch is 1mA

Reed Switches/Direct Mount Type D-Z73/Z76/Z80



Internal circuits

Lead wire colors inside [] are those prior to conformity with IEC standards.

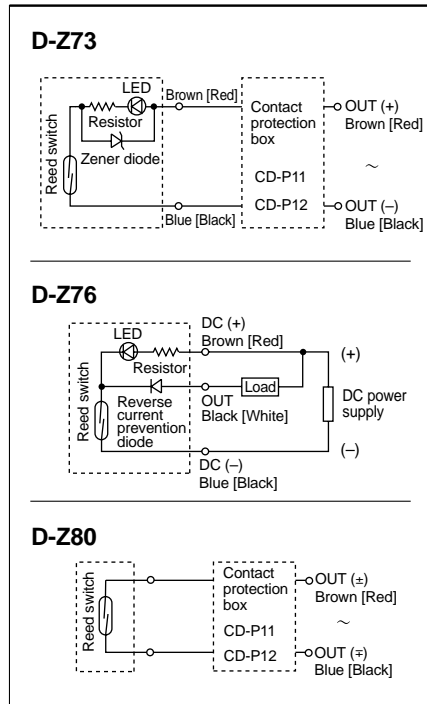

- Note) 1. The load is an induction load.
2. The lead wire length to the load is 5m or more.
3. The load voltage is 100VAC.
- Use a contact protection box in any of the above situations, as the life of the contacts may otherwise be reduced. (Refer to page 10 for detailed specifications of the contact protection boxes.)

Auto Switch Specifications

With indicator light

Auto switch part no.	D-Z73		D-Z76
Electrical entry direction	In-line		
Applicable load	Relay, PLC		IC circuit
Load voltage	24VDC	100VAC	4 to 8VDC
Maximum load current or current range	5 to 40mA	5 to 20mA	20mA
Contact protection circuit	None		
Internal voltage drop	2.4V or less (to 20mA)/3V or less (to 40mA)		0.8V or less
Indicator light	Red LED lights up when ON		

Without indicator light

Auto switch part no.	D-Z80		
Electrical entry direction	In-line		
Applicable load	Relay, PLC, IC circuit		
Load voltage	24V ^{AC} _{DC} or less	48V ^{AC} _{DC}	100V ^{AC} _{DC}
Maximum load current	50mA	40mA	20mA
Contact protection circuit	None		
Internal resistance	1Ω or less (including lead wire length of 3m)		

- Lead wire — Oil resistant heavy duty vinyl cord, ø3.4, 0.2mm², 2 wire (Brown, Blue [Red, Black]), 3 wire (Brown, Black, Blue [Red, White, Black]), 0.5m (D-Z73 only ø2.7, 0.18mm², 2 wire)

Note) Refer to page 10 for auto switch common specifications and lead wire lengths.

Weights

Model	Unit: g	
	Lead wire length 0.5m	Lead wire length 3m
D-Z73	6	31
D-Z76	10	55
D-Z80	9	49

Dimensions

D-Z73

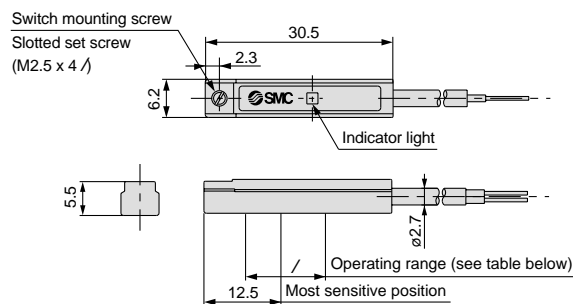

D-Z76, Z80

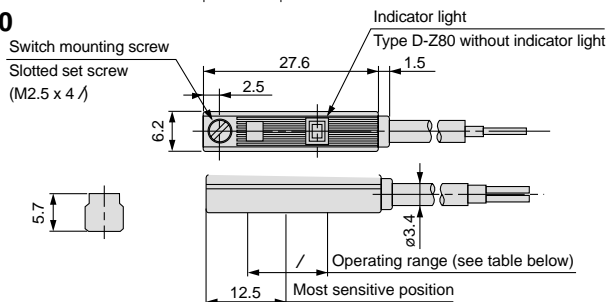

Bore size	Bore size (mm)									
	12	16	20	25	32	40	50	63	80	100
Operating range	7.5	10	10	10	10.5	10.5	10.5	11.5	11.5	12

Note) This is a standard including hysteresis, and is not guaranteed. There may be large variations depending on the surrounding environment (variations on the order of ±30%).

Solid State Switches/Direct Mount Type D-Y59^A_B/D-Y69^A_B/D-Y7P(V)



Auto Switch Specifications

D-Y5, D-Y6, D-Y7P, D-Y7PV (with indicator light)

Auto switch part no.	D-Y59A	D-Y69A	D-Y7P	D-Y7PV	D-Y59B	D-Y69B
Electrical entry direction	In-line	Perpendicular	In-line	Perpendicular	In-line	Perpendicular
Wiring type	3 wire				2 wire	
Output type	NPN		PNP		-	
Applicable load	IC circuit, Relay, PLC				24VDC relay, PLC	
Power supply voltage	5, 12, 24VDC (4.5 to 28VDC)				-	
Current consumption	10mA or less				-	
Load voltage	28VDC or less		-		24VDC (10 to 28VDC)	
Load current	40mA or less		80mA or less		5 to 40mA	
Internal voltage drop	1.5V or less (0.8V or less at 10mA load current)		0.8V or less		4V or less	
Leakage current	100μA or less at 24VDC				0.8mA or less at 24VDC	
Indicator light	Red LED lights up when ON					

• Lead wire — Oil resistant, flexible heavy duty vinyl cord, ø3.4, 0.15mm², 2 wire (Brown, Blue [Red, Black]), 3 wire (Brown, Black, Blue [Red, White, Black]), 0.5m

(Note) Refer to page 10 for auto switch common specifications and lead wire lengths.

Weights

Unit: g

Model	Lead wire length	
	0.5m	3m
D-Y59A, Y69A, Y7P, Y7PV	10	53
D-Y59B, Y69B	9	50

Internal circuits

Lead wire colors inside [] are those prior to conformity with IEC standards.

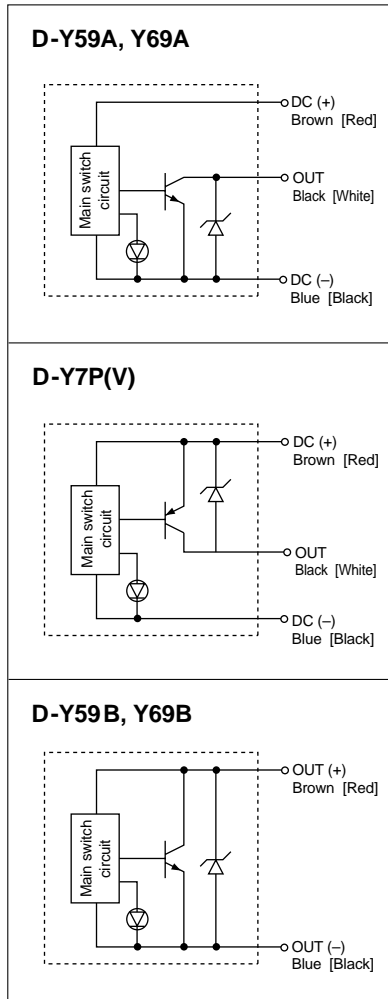

Dimensions

D-Y59A, Y59B D-Y7P

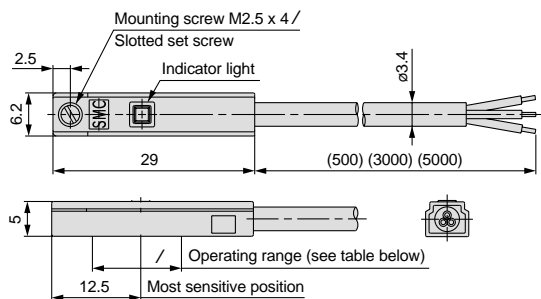

D-Y69A, Y69B D-Y7PV

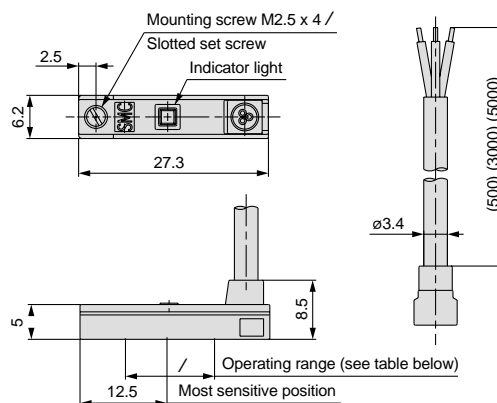

Operating range	Bore size (mm)									
	12	16	20	25	32	40	50	63	80	100
Operating range / (mm)	5.5	7.5	7.5	7	6.5	6	7	8	9.5	10

(Note) This is a standard including hysteresis, and is not guaranteed. There may be large variations depending on the surrounding environment (variations on the order of ±30%).

2 Color Indication Solid State Switches Direct Mount Type D-Y7NW(V)/Y7PW(V)/D-Y7BW(V)



Internal circuits

Lead wire colors inside [] are those prior to conformity with IEC standards.

D-Y7NW(V)/3 wire NPN output

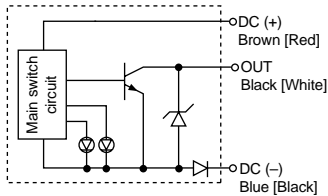

D-Y7PW(V)/3 wire PNP output

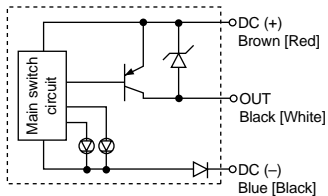

D-Y7BW(V)/2 wire

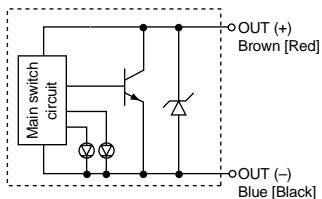

Indicator light/Display method

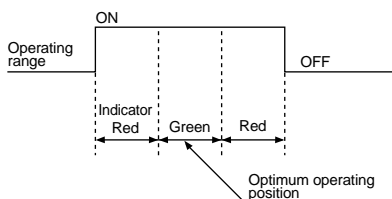

Auto Switch Specifications

D-Y7□W, D-Y7□WV (with indicator light)

Auto switch part no.	D-Y7NW	D-Y7NWV	D-Y7PW	D-Y7PWV	D-Y7BW	D-Y7BWV
Electrical entry direction	In-line	Perpendicular	In-line	Perpendicular	In-line	Perpendicular
Wiring type	3 wire			2 wire		
Output type	NPN		PNP		-	
Applicable load	IC circuit, Relay, PLC				24VDC relay, PLC	
Power supply voltage	5, 12, 24VDC (4.5 to 28VDC)				-	
Current consumption	10mA or less				-	
Load voltage	28VDC or less		-		24VDC (10 to 28VDC)	
Load current	40mA or less		80mA or less		5 to 40mA	
Internal voltage drop	1.5V or less (0.8V or less at 10mA load current)		0.8V or less		4V or less	
Leakage current	100μA or less at 24VDC				0.8mA or less at 24VDC	
Indicator light	Actuated position Red LED lights up Optimum operating position Green LED lights up					

- Lead wire — Oil resistant, flexible heavy duty vinyl cord, $\phi 3.4$, 0.15mm², 3 wire (Brown, Black, Blue [Red, White, Black]), 2 wire (Brown, Blue [Red, Black]), 0.5m
- Note) Refer to page 10 for auto switch common specifications and lead wire lengths.

Weights

Model	Lead wire length	
	0.5m	3m
D-Y7NW, D-Y7NWV, Y7PW, Y7PWV	11	54
D-Y7BW, Y7BWV	11	54

Unit: g

Dimensions

D-Y7□W

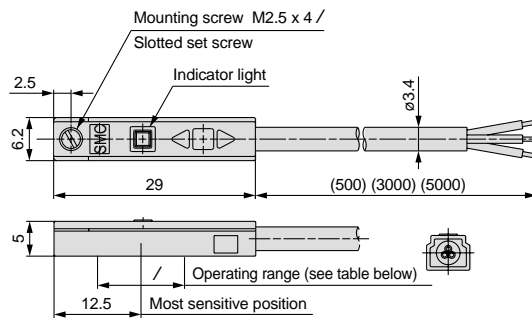

D-Y7□WV

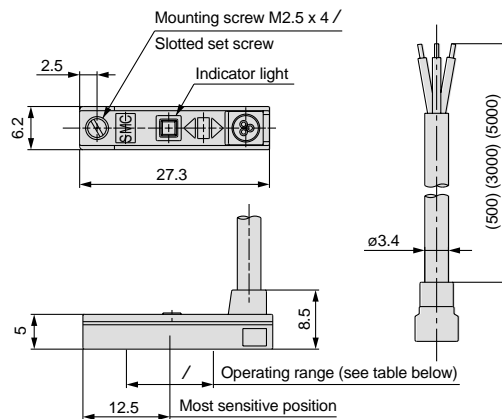

Bore size	Bore size (mm)									
	12	16	20	25	32	40	50	63	80	100
Operating range	5.5	7.5	7.5	7	6.5	6	7	8	9.5	10
Operating range /(mm)										

Note) This is a standard including hysteresis, and is not guaranteed. There may be large variations depending on the surrounding environment (variations on the order of $\pm 30\%$).

Water Resistant 2 Color Indication Solid State Switches/Direct Mount Type D-Y7BAL

Water (coolant) resistant type



Auto Switch Specifications

D-Y7BAL (with indicator light)

Auto switch model no.	D-Y7BAL
Electrical entry direction	In-line
Wiring type	2 wire
Applicable load	24VDC relay, PLC
Load voltage	24VDC (10 to 28VDC)
Load current	5 to 40mA
Internal voltage drop	4V or less
Leakage current	1mA or less at 24VDC
Indicator light	Actuated position Red LED lights up Optimum operating position Green LED lights up

• Lead wire — Oil resistant, flexible heavy duty vinyl cord, $\phi 3.4$, 0.15mm², 2 wire (Brown, Blue [Red, Black]), 3m
Note) Refer to page 10 for auto switch common specifications and lead wire lengths.

Weights

Model	Lead wire length	
	Unit: g	
D-Y7BAL	3m	
	54	

Operating Precautions

⚠ Caution

- Contact SMC if a solution other than water is to be used.

Internal circuits

Lead wire colors inside [] are those prior to conformity with IEC standards.

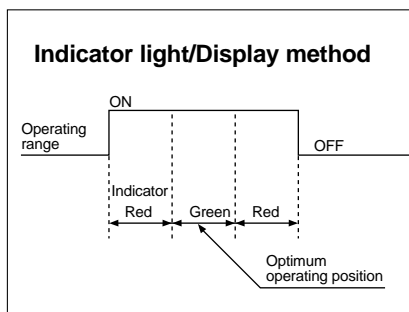
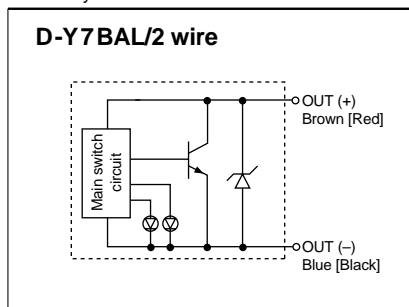

Dimensions

D-Y7BAL

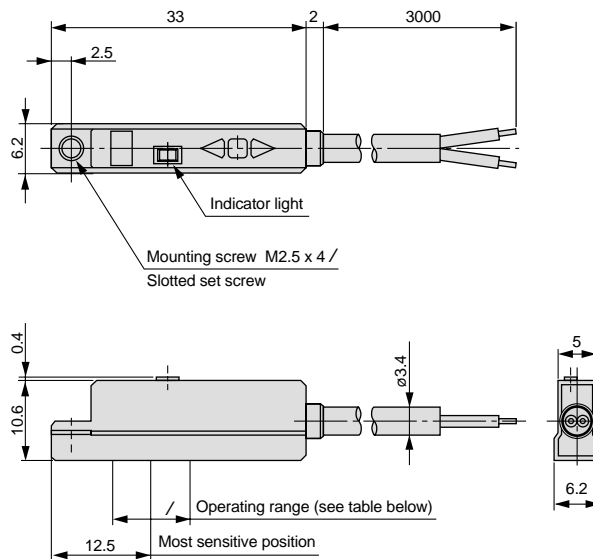

Bore size	Bore size (mm)							
	20	25	32	40	50	63	80	100
Operating range	5	5	6	6	6	6	6	6.5
Operating range / (mm)	5	5	6	6	6	6	6	6.5

Note) This is a standard including hysteresis, and is not guaranteed. There may be large variations depending on the surrounding environment (variations on the order of $\pm 30\%$).

Magnetic Field Resistant 2 Color Indication Solid State Switches/Rail Mount Type D-P5DWL

Grommet

Operational in an environment with magnetic field disturbance (AC magnetic field).



Caution

Handling Precautions

For use with single-phase AC welders. Cannot be used with DC inverter welder (includes rectifying type), arc welder, or condenser type welder.

Auto Switch Internal Circuit

Lead wire colors inside [] are those prior to conformity with IEC standards.

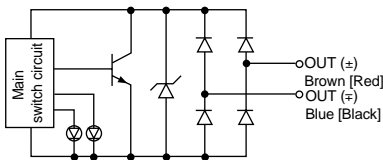

Indicator light/Display method

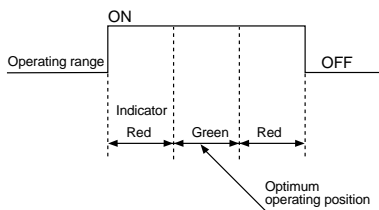

Auto Switch Specifications

D-P5DW (with indicator light)

Auto switch model no.	D-P5DWL
Wiring type	2 wire (non-polar)
Applicable load	24VDC relay, PLC
Load voltage	24VDC (20 to 28VDC)
Load current	6 to 40mA or less
Internal voltage drop	5V or less
Leakage current	1mA or less at 24VDC
Operating time	40ms or less
Indicator light	Actuated position Red LED lights up Optimum operating position ... Green LED lights up

• Lead wire — Oil resistant, heavy duty vinyl cord, $\phi 6$, 0.5mm², 2 wire (Brown, Blue [Red, Black]), 3m
Note) Refer to page 10 for auto switch common specifications and lead wire lengths.

Magnetic Field Resistance

When the AC welding current is 16000A or less, the operational distance between the welding conductor (welding gun or cable) and the cylinder or auto switch can be 0mm. Consult SMC when exceeding 16000A.

Auto Switch Weights

Model	Lead wire length	
	3m	5m □
D-P5DWL	150	240

Unit: g

Dimensions

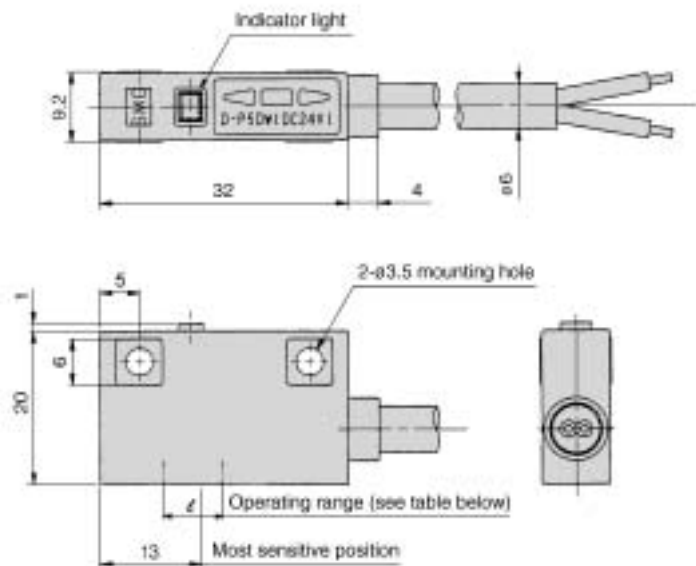

Operating range	Bore size (mm)				
	40	50	63	80	100
Operating range / (mm)	4.1	3.9	4.8	4.2	4.2

Note) This is a standard including hysteresis, and is not guaranteed. There may be large variations depending on the surrounding environment (variations on the order of $\pm 30\%$).



Series *MLGP* Safety Instructions

These safety instructions are intended to prevent a hazardous situation and/or equipment damage. These instructions indicate the level of potential hazard by a label of "**Caution**", "**Warning**" or "**Danger**". To ensure safety, be sure to observe ISO 4414 Note 1), JIS B 8370 Note 2) and other safety practices.

 **Caution** : Operator error could result in injury or equipment damage.

 **Warning** : Operator error could result in serious injury or loss of life.

 **Danger** : In extreme conditions, there is a possible result of serious injury or loss of life.

Note 1) ISO 4414: Pneumatic fluid power – Recommendations for the application of equipment to transmission and control systems

Note 2) JIS B 8370: General Rules for Pneumatic Equipment

Warning

1. The compatibility of pneumatic equipment is the responsibility of the person who designs the pneumatic system or decides its specifications.

Since the products specified here are used in various operating conditions, their compatibility for the specific pneumatic system must be based on specifications or after analysis and/or tests to meet your specific requirements.

2. Only trained personnel should operate pneumatically operated machinery and equipment.

Compressed air can be dangerous if an operator is unfamiliar with it. Assembly, handling or repair of pneumatic systems should be performed by trained and experienced operators.

3. Do not service machinery/equipment or attempt to remove components until safety is confirmed.

1. Inspection and maintenance of machinery/equipment should only be performed after confirmation of safe locked-out control positions.
2. When equipment is to be removed, confirm the safety process as mentioned above. Cut the supply pressure for this equipment and exhaust all residual compressed air in the system.
3. Before machinery/equipment is restarted, take measures to prevent shooting-out of cylinder piston rod, etc. (Bleed air into the system gradually to create back pressure.)

4. Contact SMC if the product is to be used in any of the following conditions:

1. Conditions and environments beyond the given specifications, or if product is used outdoors.
2. Installation on equipment in conjunction with atomic energy, railway, air navigation, vehicles, medical equipment, food and beverages, recreation equipment, emergency stop circuits, press applications, or safety equipment.
3. An application which has the possibility of having negative effects on people, property, or animals, requiring special safety analysis.



Series MLGP Actuator Precautions 1

Be sure to read before handling.

Design

⚠ Warning

1. **There is a possibility of dangerous sudden action by air cylinders if sliding parts of machinery are twisted due to external forces, etc.**

In such cases, human injury may occur; e.g., by catching hands or feet in the machinery, or damage to the machinery itself may occur. Therefore, the machine should be designed to avoid such dangers.

2. **A protective cover is recommended to minimize the risk of personal injury.**

If a stationary object and moving parts of a cylinder are in close proximity, personal injury may occur. Design the structure to avoid contact with the human body.

3. **Securely tighten all stationary parts and connected parts so that they will not become loose.**

Especially when a cylinder operates with high frequency or is installed where there is a lot of vibration, ensure that all parts remain secure.

4. **A deceleration circuit or shock absorber, etc., may be required.**

When a driven object is operated at high speed or the load is heavy, a cylinder's cushion will not be sufficient to absorb the shock. Install a deceleration circuit to reduce the speed before cushioning, or install an external shock absorber to relieve the shock. In this case, the rigidity of the machinery should also be examined.

5. **Consider emergency stops.**

Design so that human injury and/or damage to machinery and equipment will not be caused when machinery is stopped by a safety device under abnormal conditions, a power outage or a manual emergency stop.

6. **Consider the action when operation is restarted after an emergency stop or abnormal stop.**

Design the machinery so that human injury or equipment damage will not occur upon restart of operation. When the cylinder has to be reset at the starting position, install safe manual control equipment.

Selection

⚠ Warning

1. **Check the specifications.**

The products advertised in this catalog are designed according to use in industrial compressed air systems. If the products are used in conditions where pressure, temperature, etc., are out of specification, damage and/or malfunction may be caused. Do not use in these conditions.

Consult SMC if you use a fluid other than compressed air.

⚠ Caution

1. **Operate within the limits of the maximum usable stroke.**

The piston rod will be damaged if operated beyond the maximum stroke. Refer to the air cylinder model selection procedures for the maximum usable stroke.

2. **Operate the piston within a range such that collision damage will not occur at the stroke end.**

Operate within a range such that damage will not occur when the piston having inertial force stops by striking the cover at the stroke end. Refer to the cylinder model selection procedure for the range within which damage will not occur.

3. **Use a speed controller to adjust the cylinder drive speed, gradually increasing from a low speed to the desired speed setting.**

Mounting

⚠ Caution

1. **Do not scratch or gouge the sliding parts of the cylinder tube or piston rod, etc., by striking or grasping them with other objects.**

Cylinder bores are manufactured to precise tolerances, so that even a slight deformation may cause malfunction.

Moreover, scratches or gouges, etc., in the piston rod may lead to damaged seals and cause air leakage.

2. **Do not use until you verify that the equipment can operate properly.**

After mounting, repair or modification, etc., connect the air supply and electric power, and then confirm proper mounting by means of appropriate function and leak tests.

3. **Instruction manual**

The product should be mounted and operated after thoroughly reading the manual and understanding its contents.

Keep the instruction manual where it can be referred to as needed.



Series MLGP Actuator Precautions 2

Be sure to read before handling.

Piping

⚠ Caution

1. Preparation before piping

Before piping is connected, it should be thoroughly blown out with air (flushing) or washed to remove chips, cutting oil and other debris from inside the pipe.

2. Wrapping of pipe tape

When screwing together pipes and fittings, etc., be certain that chips from the pipe threads and sealing material do not get inside the piping.

Also, when pipe tape is used, leave 1.5 to 2 thread ridges exposed at the end of the pipe.

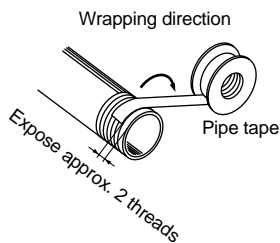

Lubrication

⚠ Caution

1. Lubrication of cylinder

The cylinder has been lubricated for life at the factory and can be used without any further lubrication.

Air Supply

⚠ Warning

1. Use clean air.

Do not use compressed air that includes chemicals, synthetic oils containing organic solvents, salt or corrosive gases, etc., as it can cause damage or malfunction.

⚠ Caution

1. Install air filters.

Install air filters at the upstream side of valves. The filtration degree should be 5 μ m or finer.

2. Install an after-cooler, air dryer or water separator, etc.

Air that includes much drainage can cause malfunction of valves and other pneumatic equipment. To prevent this, install an after-cooler, air dryer or water separator, etc.

3. Use the product within the range of specifications for fluid temperature and ambient temperature.

Take measures to prevent freezing, since moisture in circuits can freeze under 5°C, and this may cause damage to seals and lead to malfunction.

Refer to the "Air Cleaning Equipment" catalog for details on compressed air quality.

Operating Environment

⚠ Warning

1. Do not use in environments where there is a danger of corrosion.

Refer to the construction drawings regarding cylinder materials.

2. In dusty locations or where water or oil, etc., splash on the equipment, install a protective cover, etc.

Maintenance

⚠ Warning

1. Perform maintenance according to the procedure indicated in the instruction manual.

If handled improperly, malfunction and damage of machinery or equipment may occur.

2. Removal of equipment, and supply and exhaust of compressed air.

When removing equipment, first check measures to prevent dropping of driven objects and run-away of equipment, etc. Then cut off the supply pressure and electric power, and exhaust all compressed air from the system.

When machinery is restarted, proceed with caution after confirming measures to prevent lurching.

⚠ Caution

1. Drain flushing

Remove drainage from air filters regularly.



Series MLGP Auto Switch Precautions 1

Be sure to read before handling.

Design and Selection

Warning

1. Confirm the specifications.

Read the specifications carefully and use this product appropriately. The product may be damaged or malfunction if it is used outside the range of specifications of current load, voltage, temperature or impact.

2. Take precautions when multiple cylinders are used close together.

When multiple auto switch cylinders are used in close proximity, magnetic field interference may cause the switches to malfunction. Maintain a minimum cylinder separation of 40mm.

3. Pay attention to the length of time that a switch is ON at an intermediate stroke position.

When an auto switch is placed at an intermediate position of the stroke and a load is driven at the time the piston passes, the auto switch will operate, but if the speed is too great the operating time will be shortened and the load may not operate properly. The maximum detectable piston speed is:

$$V(\text{mm/s}) = \frac{\text{Auto switch operating range (mm)}}{\text{Load operating speed (ms)}} \times 1000$$

4. Keep wiring as short as possible.

<Reed switch>

As the length of the wiring to a load gets longer, the rush current at switching ON becomes greater, and this may shorten the product's life. (The switch will stay ON all the time.)

- 1) For an auto switch without a contact protection circuit, use a contact protection box when the wire length is 5m or longer.

<Solid state switch>

- 2) Although wire length should not affect switch function, use a wire 100m or shorter.

5. Take note of the internal voltage drop of the switch.

<Reed switch>

- 1) Switches with an indicator light (Except D-Z76)

- If auto switches are connected in series as shown below, take note that there will be a large voltage drop because of internal resistance in the light emitting diodes. (Refer to internal voltage drop in the auto switch specifications.)

[The voltage drop will be "n" times larger when "n" auto switches are connected.]

Even though an auto switch operates normally, the load may not operate.

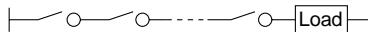

- In the same way, when operating below a specified voltage, although an auto switch may operate normally, the load may not operate. Therefore, the formula below should be satisfied after confirming the minimum operating voltage of the load.

$$\text{Supply voltage} - \frac{\text{Internal voltage drop of switch}}{\text{Minimum operating voltage of load}} >$$

- 2) If the internal resistance of a light emitting diode causes a problem, select a switch without an indicator light (Model D-Z80).

<Solid state switch>

- 3) Generally, the internal voltage drop will be greater with a 2 wire solid state auto switch than with a reed switch. Take the same precautions as in 1).

Also, note that a 12VDC relay is not applicable.

6. Pay attention to leakage current.

<Solid state switch>

With a 2 wire solid state auto switch, current (leakage current) flows to the load to operate the internal circuit even when in the OFF state.

$$\text{Operating current of load (OFF condition)} > \text{Leakage current}$$

If the criteria given in the above formula are not met, it will not reset correctly (stays ON). Use a 3 wire switch if this specification will not be satisfied.

Moreover, leakage current flow to the load will be "n" times larger when "n" auto switches are connected in parallel.

7. Do not use a load that generates surge voltage.

<Reed switch>

If driving a load such as a relay that generates a surge voltage, use a contact protection box.

<Solid state switch>

Although a zener diode for surge protection is connected at the output side of a solid state auto switch, damage may still occur if the surge is applied repeatedly. When a load, such as a relay or solenoid, which generates surge is directly driven, use a type of switch with a built-in surge absorbing element.

8. Cautions for use in an interlock circuit

When an auto switch is used for an interlock signal requiring high reliability, devise a double interlock system to avoid trouble by providing a mechanical protection function, or by also using another switch (sensor) together with the auto switch.

Also perform periodic maintenance and confirm proper operation.

9. Ensure sufficient clearance for maintenance activities.

When designing an application, be sure to allow sufficient clearance for maintenance and inspections.



Series MLGP Auto Switch Precautions 2

Be sure to read before handling.

Mounting and Adjustment

Warning

1. Do not drop or bump.

Do not drop, bump or apply excessive impacts (300m/s² or more for reed switches and 1000m/s² or more for solid state switches) while handling.

Although the body of the switch may not be damaged, the inside of the switch could be damaged and cause a malfunction.

2. Do not carry a cylinder by the auto switch lead wires.

Never carry a cylinder by its lead wires. This may not only cause broken lead wires, but it may cause internal elements of the switch to be damaged by the stress.

3. Mount switches using the proper fastening torque.

When a switch is tightened beyond the range of fastening torque, the mounting screws or switch may be damaged. On the other hand, tightening below the range of fastening torque may allow the switch to slip out of position.

4. Mount a switch at the center of the operating range.

Adjust the mounting position of an auto switch so that the piston stops at the center of the operating range (the range in which a switch is ON).

(The mounting position shown in a catalog indicates the optimum position at stroke end.) If mounted at the end of the operating range (around the borderline of ON and OFF), operation may be unstable.

Wiring

Warning

1. Avoid repeatedly bending or stretching lead wires.

Broken lead wires will result from applying bending stress or stretching force to the lead wires.

2. Be sure to connect the load before power is applied.

<2 wire type>

If the power is turned ON when an auto switch is not connected to a load, the switch will be instantly damaged because of excess current.

3. Confirm proper insulation of wiring.

Be certain that there is no faulty wiring insulation (contact with other circuits, ground fault, improper insulation between terminals, etc.). Damage may occur due to excess current flow into a switch.

4. Do not wire with power lines or high voltage lines.

Wire separately from power lines or high voltage lines, avoiding parallel wiring or wiring in the same conduit with these lines. Control circuits including auto switches may malfunction due to noise from these other lines.

5. Do not allow short circuit of loads.

<Reed switch>

If the power is turned ON with a load in a short circuited condition, the switch will be instantly damaged because of excess current flow into the switch.

<Solid state switch>

All models of PNP output type switches do not have built-in short circuit protection circuits. If loads are short circuited, the switches will be instantly damaged, as in the case of reed switches.

* Take special care to avoid reverse wiring with the power supply line (brown [red]) and the output line (black [white]) on 3 wire type switches.

6. Avoid incorrect wiring.

<Reed switch>

* A 24VDC switch with indicator light has polarity. The brown [red] lead wire or terminal No.1 is (+) and the blue [black] lead wire or terminal No.2 is (-).

1) If connections are reversed, a switch will operate, however, the light emitting diode will not light up.

Also note that a current greater than that specified will damage a light emitting diode and it will no longer operate.

Applicable models:
Z-73

<Solid state switch>

1) If connections are reversed on a 2 wire type switch, the switch will not be damaged if protected by a protection circuit, but the switch will always stay in an ON state. However, it is still necessary to avoid reversed connections, since the switch could be damaged by a load short circuit in this condition.

*2) If connections are reversed (power supply line + and power supply line -) on a 3 wire type switch, the switch will be protected by a protection circuit. However, if the power supply line (+) is connected to the blue [black] wire and the power supply line (-) is connected to the black [white] wire, the switch will be damaged.

* Lead wire color changes

Lead wire colors of SMC auto switches have been changed in order to meet NECA Standard 0402 for production beginning September, 1996 and thereafter. Please refer to the tables provided.

Special care should be taken regarding wire polarity during the time that the old colors still coexist with the new colors.

2 wire

	Old	New
Output (+)	Red	Brown
Output (-)	Black	Blue

Solid state with diagnostic output

	Old	New
Power supply	Red	Brown
GND	Black	Blue
Output	White	Black
Diagnostic output	Yellow	Orange

3 wire

	Old	New
Power supply	Red	Brown
GND	Black	Blue
Output	White	Black

Solid state with latch type diagnostic output

	Old	New
Power supply	Red	Brown
GND	Black	Blue
Output	White	Black
Latch type diagnostic output	Yellow	Orange



Series MLGP Auto Switch Precautions 3

Be sure to read before handling.

Operating Environment

⚠ Warning

1. Never use in an atmosphere of explosive gases.

The construction of auto switches is not intended to prevent explosion. Never use in an atmosphere with an explosive gas since this may cause a serious explosion.

2. Do not use in an area where a magnetic field is generated.

Auto switches will malfunction or magnets inside cylinders will become demagnetized. (Consult SMC regarding the availability of a magnetic field resistant auto switch.)

3. Do not use in an environment where the auto switch will be continually exposed to water.

Although switches, except for some models, satisfy IEC standard IP67 construction (JIS C 0920: watertight construction), do not use switches in applications where continually exposed to water splash or spray. Poor insulation or swelling of the potting resin inside switches may cause malfunction.

4. Do not use in an environment with oil or chemicals.

Consult SMC if auto switches will be used in an environment with coolant, cleaning solvent, various oils or chemicals. If auto switches are used under these conditions for even a short time, they may be adversely affected by improper insulation, malfunction due to swelling of the potting resin, or hardening of the lead wires.

5. Do not use in an environment with temperature cycles.

Consult SMC if switches are used where there are temperature cycles other than normal temperature changes, as they may be adversely affected internally.

6. Do not use in an environment where there is excessive impact shock.

<Reed switch>

When excessive impact (300m/s² or more) is applied to a reed switch during operation, the contact point will malfunction and generate or cut off a signal momentarily (1ms or less). Consult SMC regarding the need to use a solid state switch depending upon the environment.

7. Do not use in an area where surges are generated.

<Solid state switch>

When there are units (solenoid type lifter, high frequency induction furnace, motor, etc.) which generate a large amount of surge in the area around cylinders with solid state auto switches, this may cause deterioration or damage to the switches. Avoid sources of surge generation and crossed lines.

8. Avoid accumulation of iron debris or close contact with magnetic substances.

When a large amount of ferrous debris such as machining chips or spatter is accumulated, or a magnetic substance (something attracted by a magnet) is brought into close proximity with an auto switch cylinder, it may cause auto switches to malfunction due to a loss of the magnetic force inside the cylinder.

Maintenance

⚠ Warning

1. Perform the following maintenance periodically in order to prevent possible danger due to unexpected auto switch malfunction.

- 1) Securely tighten switch mounting screws.

If screws become loose or the mounting position is dislocated, retighten them after readjusting the mounting position.

- 2) Confirm that there is no damage to lead wires.

To prevent faulty insulation, replace switches or repair lead wires, etc., if damage is discovered.

- 3) Confirm the lighting of the green light on the 2 color indicator type switch.

Confirm that the green LED is on when stopped at the established position. If the red LED is on, the mounting position is not appropriate. Readjust the mounting position until the green LED lights up.

Other

⚠ Warning

1. Consult SMC concerning water resistance, elasticity of lead wires, and usage of general purpose auto switches at welding sites, etc.



Series MLGP Specific Product Precautions 1

Be sure to read before handling.

Refer to pages 17 through 22 for safety instructions, actuator precaution and auto switch precautions.

Selection

Warning

- Do not use this cylinder for intermediate stops.**
This cylinder is designed for locking against inadvertent movement from a stationary condition. Do not perform intermediate stops while the cylinder is operating, as this will shorten its service life.
- Select the correct locking direction, as this cylinder does not generate holding force opposite to the locking direction.**
The extension lock does not generate holding force in the cylinder's retracting direction, and the retraction lock does not generate holding force in the cylinder's extending direction (free).
- Even when locked, there may be stroke movement of about 1mm in the locking direction due to external forces such as the weight of the work piece.**
Even when locked, if air pressure drops, stroke movement of about 1mm may be generated in the locking direction of the lock mechanism due to external forces such as the work piece weight.
- When locked, do not apply impact loads, strong vibration or rotational force, etc.**
When used as a stopper, be careful that the work piece does not collide with the cylinder in a locked condition.
- Operate so that load weight, cylinder speed and eccentric distance are within the limiting ranges in the specifications and model selection graphs.**
Operation beyond the limiting range will lead to cylinder damage and reduced service life, etc. (Refer to pages 2 and 3 and "Model Selection" for specifications.)

Pneumatic Circuits

Warning

- Do not use 3 position valves.**
The lock may be released due to inflow of the unlocking pressure.
- Install speed controllers for meter-out control.**
Malfunction may occur if used with meter-in control.
- Be careful of reverse exhaust pressure flow from a common exhaust type valve manifold.**
Since the lock may be released due to reverse exhaust pressure flow, use an individual exhaust type manifold or single type valve.
- Branch off the compressed air piping for the lock unit between the cylinder and the speed controller.**
Note that branching off in another section can cause a reduction in service life.
- Perform piping so that the side going from the piping junction to the lock unit is short.**
If the lock unit side piping is longer than the cylinder port side, this may cause unlocking malfunction and reduce the life of the lock, etc.

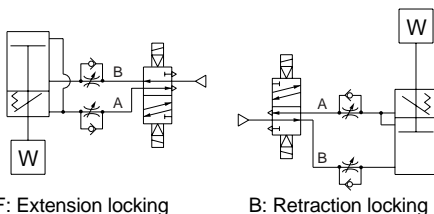

Mounting

Warning

- Do not put hands or fingers, etc., in between the plate and the cylinder body or lock body.**
Be very careful that hands or fingers, etc., are not caught in the space between the plate and the cylinder body or lock body when air pressure is applied.

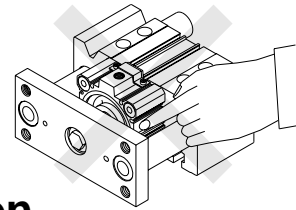

Caution

- Be sure to connect the load to the plate section with the lock in an unlocked condition.**
If this is done with the lock in a locked condition, the locking mechanism may be damaged.
Sizes $\phi 20$ through $\phi 32$ have a built-in holding function for the unlocked condition, allowing the unlocked condition to be maintained even without an air supply. For $\phi 40$ through $\phi 100$, simply connect piping to the unlocking port and supply air pressure of 0.2MPa or more.
- When performing mounting adjustment, supply air pressure only to the unlocking port.**
- Cylinder bottom**
Since the guide rods project from the bottom of the cylinder at the end of the retraction stroke, provide by-pass ports in the mounting surface, as well as holes for the hexagon socket head mounting screws, when the cylinder is mounted from the bottom. Furthermore, when subjected to impact in use as a stopper, etc., screw the mounting bolts in to a depth of $2d$ or more.

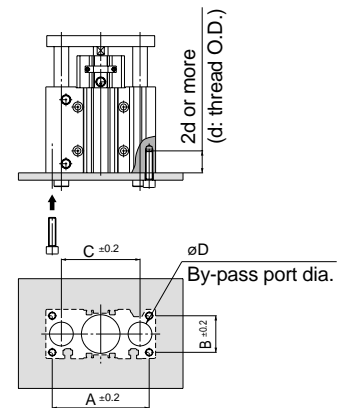

Bore size (mm)	A (mm)	B (mm)	C (mm)	D		Hexagon socket head mounting screws
				MGPM	MGPL	
20	72	24	54	14	12	M5 x 0.8
25	82	30	64	18	15	M6 x 1.0
32	98	34	78	22	18	M8 x 1.25
40	106	40	86	22	18	M8 x 1.25
50	130	46	110	27	22	M10 x 1.5
63	142	58	124	27	22	M10 x 1.5
80	180	54	156	33	28	M12 x 1.75
100	210	62	188	39	33	M14 x 2.0



Series MLGP Specific Product Precautions 2

Be sure to read before handling.

Refer to pages 17 through 22 for safety instructions, actuator precaution and auto switch precautions.

Piping

Warning

Depending on the operating condition, change the position of plugs for the piping port.

1. For M5

After tightening by hand, tighten additional 1/6 to 1/4 rotation with a tightening tool.

2. For Rc threads

Tighten with proper tightening torques below. Also, use pipe tape on the plug.

Connection thread size	Proper tightening torque N·m
R 1/8	7 to 9
R 1/4	12 to 14
R 3/8	22 to 24

Preparing for Operation

Warning

1. Before starting operation from the locked position, be sure to restore air pressure to the B port in the pneumatic circuit.

It is very dangerous to apply pressure to the A port with the B port in an unpressurized state, because the cylinder will move suddenly when unlocked.

2. Since sizes $\phi 20$ through $\phi 32$ are shipped in an unlocked condition maintained by the unlocking bolt, be sure to remove the unlocking bolt following the procedures below. If the cylinder is used without removing the unlocking bolt, the lock mechanism will not function. Sizes $\phi 40$ through $\phi 100$ do not have the holding function for the unlocked condition, and therefore, they can be used as shipped.

For $\phi 20$ through $\phi 32$ only

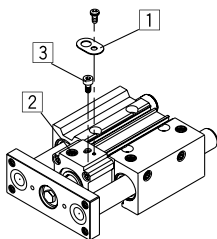

- 1) Confirm that there is no air pressure inside the cylinder, and remove the dust cover 1.
- 2) Supply air pressure of 0.2MPa or more into the unlocking port 2.
- 3) Remove the unlocking bolt 3 with a hexagon wrench (width across flats 2.5).

Manual Unlocking

Warning

1. Do not perform unlocking when an external force such as a load or spring force is being applied.

This is very dangerous because the cylinder will move suddenly. Take the following steps.

- 1) Release the lock after restoring the air pressure in the B line of the pneumatic circuit to operating pressure, and then reduce the pressure gradually.
- 2) In case air pressure cannot be used, release the lock after preventing cylinder movement with a lifting device such as a jack.

2. After confirming safety, operate the manual release following the steps shown below.

Carefully confirm that personnel are not inside the load movement range, etc., and that there is no danger even if the load moves suddenly.

Manual unlocking
For $\phi 20$ through $\phi 32$

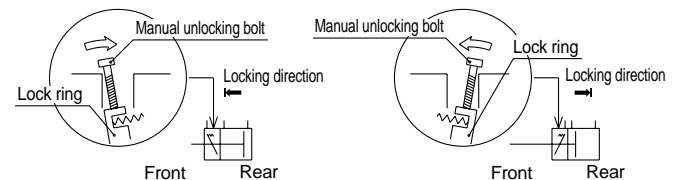

Extension locking

- 1) Remove the dust cover.
- 2) Screw in the manual unlocking bolt (commercial bolt size M3 x 0.5 x 15/or more) into the lock ring threads, and lightly push it in the direction of the arrow (rear), as shown above, to unlock.

Retraction locking

- 1) Remove the dust cover.
- 2) Screw in the manual unlocking bolt (commercial bolt size M3 x 0.5 x 15/or more) into the lock ring threads, and lightly push it in the direction of the arrow (front), as shown above, to unlock.

For normal operation, remove the manual unlocking bolt. It will cause lock malfunction.

For $\phi 40$ through $\phi 100$

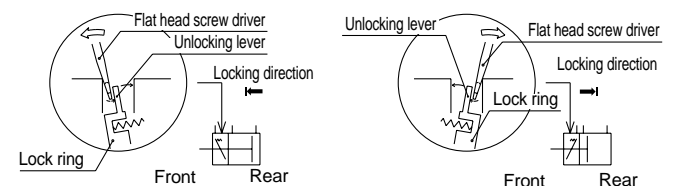

Extension locking

- 1) Remove the dust cover.
- 2) Insert a flat head screw driver on the rod side of the manual unlocking lever as shown in the figure above, and lightly push down the screw driver in the direction of the arrow (front), as shown above, to unlock.

Retraction locking

- 1) Remove the dust cover.
- 2) Insert a flat head screw driver on the head side of the manual unlocking lever as shown in the figure above, and lightly push down the screw driver in the direction of the arrow (rear), as shown above, to unlock.



Series MLGP Specific Product Precautions 3

Be sure to read before handling.

Refer to pages 17 through 22 for safety instructions, actuator precaution and auto switch precautions.

Holding the Unlocked Condition (ø20 through ø32)

⚠ Caution

1. In order to hold the locked condition, be sure to follow the procedures below after confirming safety.

- 1) Remove the dust cover **1**.
- 2) Supply air pressure of 0.2MPa or more to the unlocking port **2** shown below and unlock.
- 3) Screw in the hexagon socket head cap bolt **3** (ø20, ø25: M3 x 0.5 x 5, ø32: M3 x 0.5 x 10), included, into the lock ring and hold the unlocked condition.

2. To use the lock mechanism again, be sure to remove the unlocking bolt.

When the unlocking bolt is screwed in, the lock mechanism will not function. Remove the unlocking bolt according to the procedures for the side prepared for operation.

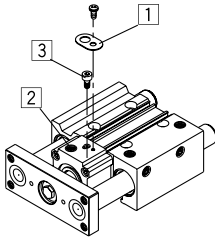

Maintenance

⚠ Caution

1. In order to maintain good performance, operate with clean unlubricated air.

If lubricated air, compressor oil or drainage, etc., enter the cylinder, there is a danger of sharply reducing the locking performance.

2. Do not apply grease to the piston rod.

There is a danger of sharply reducing the locking performance.

3. For ø20 through ø32, a ø12 silver seal is placed on one side of the lock body (the side opposite the unlocking port). This seal is applied for dust protection; however, even if it is removed, there will be no functional problem.

4. Never disassemble the lock unit.

It contains a heavy duty spring which is dangerous, and there is also a danger of reducing locking performance.



SMC'S GLOBAL MANUFACTURING, DISTRIBUTION AND SERVICE NETWORK

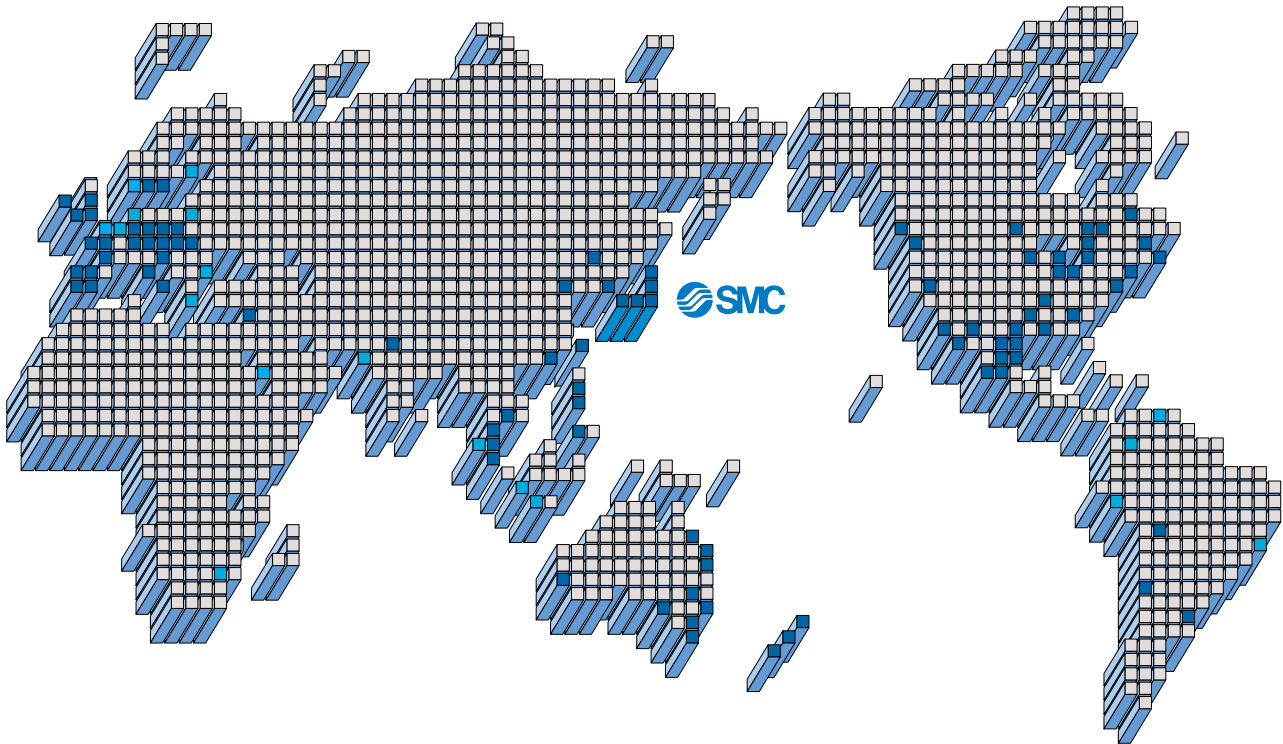

EUROPE

AUSTRIA
SMC Pneumatik GmbH

CZECH
SMC Czech s.r.o.

DENMARK
SMC Pneumatik A/S

FINLAND
SMC Pneumatiikka OY

FRANCE
SMC Pneumatique SA

GERMANY
SMC Pneumatik GmbH

HUNGARY
SMC Hungary Kft.

IRELAND
SMC Pneumatics (Ireland) Ltd.

ITALY
SMC Italia S.p.A.

NETHERLANDS
SMC Pneumatics BV.

NORWAY
SMC Pneumatics Norway A/S

ROMANIA
SMC Romania s.r.l.

RUSSIA
SMC Pneumatik LLC.

SLOVAKIA
SMC Slovakia s.r.o.

SLOVENIA
SMC Slovenia d.o.o.

EUROPE

SPAIN/PORTUGAL
SMC España, S.A.

SWEDEN
SMC Pneumatics Sweden AB

SWITZERLAND
SMC Pneumatik AG.

UK
SMC Pneumatics (U.K.) Ltd.

ASIA

CHINA
SMC (China) Co., Ltd.

HONG KONG
SMC Pneumatics (Hong Kong) Ltd.

INDIA
SMC Pneumatics (India) Pvt. Ltd.

MALAYSIA
SMC Pneumatics (S.E.A.) Sdn. Bhd.

PHILIPPINES
SMC Pneumatics (Philippines), Inc.

SINGAPORE
SMC Pneumatics (S.E.A.) Pte. Ltd.

SOUTH KOREA
SMC Pneumatics Korea Co., Ltd.

TAIWAN
SMC Pneumatics (Taiwan) Co., Ltd.

THAILAND
SMC Thailand Ltd.

NORTH AMERICA

CANADA
SMC Pneumatics (Canada) Ltd.

MEXICO
SMC Corporation (Mexico) S.A. de C.V.

USA
SMC Pneumatics, Inc.

SOUTH AMERICA

ARGENTINA
SMC Argentina S.A.

BOLIVIA
SMC Pneumatics Bolivia S.R.L.

BRAZIL
SMC Pneumaticos Do Brazil Ltda.

CHILE
SMC Pneumatics (Chile) S.A.

VENEZUELA
SMC Neumatica Venezuela S.A.

OCEANIA

AUSTRALIA
SMC Pneumatics (Australia) Pty. Ltd.

NEW ZEALAND
SMC Pneumatics (N.Z.) Ltd.

SMC CORPORATION

1-16-4 Shimbashi, Minato-ku, Tokyo 105-0004, JAPAN
Tel: 03-3502-2740 Fax: 03-3508-2480
URL <http://www.smcworld.com>
© 2000 SMC CORPORATION All Rights Reserved