



Operation Manual

PRODUCT NAME

IONIZER

MODEL/Series

IZF10 series

SMC Corporation

Contents

Safety Instructions	3
1. How to Order	8
1-1. Ionizer	8
1-2. Accessory	8
1-3. Maintenance parts	9
1-4. Option	9
2. Procedure	10
3. Installation and wiring	10
3-1. Installation	10
3-1-1. Precautions for installation	10
3-1-2. Mounting	11
3-2. Wiring	12
3-2-1. Wiring diagram and Wiring table	12
3-2-2. Connection cable and connector	14
3-2-3. Wiring of the power supply cable	14
3-2-4. Wiring of the AC adapter	14
3-3. Timing chart	15
4. Functions	15
4-1. Description of components	15
4-2. Fine adjustment of ion balance	16
4-3. Detection and cleaning of contamination on the electrodes	16
4-4. Replacement of the cartridge case	17
4-5. Alarm function	17
5. Electricity Removal Characteristics	18
6. Dimensions	19
7. Specifications	21



IONIZER

Safety Instructions

These safety instructions are intended to prevent hazardous situations and/or equipment damage. These instructions indicate the level of potential hazard with the labels of "Caution," "Warning" or "Danger." They are all important notes for safety and must be followed in addition to International Standards (ISO/IEC)*1, and other safety regulations.

*1) ISO 4414: Pneumatic fluid power -- General rules relating to systems.

ISO 4413: Hydraulic fluid power -- General rules relating to systems.

IEC 60204-1: Safety of machinery -- Electrical equipment of machines .(Part 1: General requirements)

ISO 10218-1992: Manipulating industrial robots -Safety.

etc.



Caution

Operator error could result in injury or equipment damage.



Warning

Operator error could result in serious injury or loss of life.



Danger

In extreme conditions, there is a possibility of serious injury or loss of life.

Warning

1. The compatibility of the product is the responsibility of the person who designs the equipment or decides its specifications.

Since the product specified here is used under various operating conditions, its compatibility with specific equipment must be decided by the person who designs the equipment or decides its specifications based on necessary analysis and test results.

The expected performance and safety assurance of the equipment will be the responsibility of the person who has determined its compatibility with the product.

This person should also continuously review all specifications of the product referring to its latest catalog information, with a view to giving due consideration to any possibility of equipment failure when configuring the equipment.

2. Only personnel with appropriate training should operate machinery and equipment.

The product specified here may become unsafe if handled incorrectly.

The assembly, operation and maintenance of machines or equipment including our products must be performed by an operator who is appropriately trained and experienced.

3. Do not service or attempt to remove product and machinery/equipment until safety is confirmed.

1.The inspection and maintenance of machinery/equipment should only be performed after measures to prevent falling or runaway of the driven objects have been confirmed.

2.When the product is to be removed, confirm that the safety measures as mentioned above are implemented and the power from any appropriate source is cut, and read and understand the specific product precautions of all relevant products carefully.

3. Before machinery/equipment is restarted, take measures to prevent unexpected operation and malfunction.

4. Contact SMC beforehand and take special consideration of safety measures if the product is to be used in any of the following conditions.

1. Conditions and environments outside of the given specifications, or use outdoors or in a place exposed to direct sunlight.

2. Installation on equipment in conjunction with atomic energy, railways, air navigation, space, shipping, vehicles, military, medical treatment, combustion and recreation, or equipment in contact with food and beverages, emergency stop circuits, clutch and brake circuits in press applications, safety equipment or other applications unsuitable for the standard specifications described in the product catalog.

3. An application which could have negative effects on people, property, or animals requiring special safety analysis.

4.Use in an interlock circuit, which requires the provision of double interlock for possible failure by using a mechanical protective function, and periodical checks to confirm proper operation.

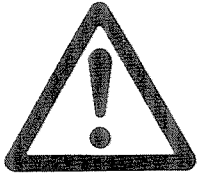

IONIZER

Safety Instructions

Caution

1. The product is provided for use in manufacturing industries.

The product herein described is basically provided for peaceful use in manufacturing industries.

If considering using the product in other industries, consult SMC beforehand and exchange specifications or a contract if necessary.

If anything is unclear, contact your nearest sales branch.

Limited warranty and Disclaimer/Compliance Requirements

The product used is subject to the following "Limited warranty and Disclaimer" and "Compliance Requirements". Read and accept them before using the product.

Limited warranty and Disclaimer

1. The warranty period of the product is 1 year in service or 1.5 years after the product is delivered.*2)

Also, the product may have specified durability, running distance or replacement parts. Please consult your nearest sales branch.

2. For any failure or damage reported within the warranty period which is clearly our responsibility, a replacement product or necessary parts will be provided.

This limited warranty applies only to our product independently, and not to any other damage incurred due to the failure of the product.

3. Prior to using SMC products, please read and understand the warranty terms and disclaimers noted in the specified catalog for the particular products.

*2) Vacuum pads are excluded from this 1 year warranty.

A vacuum pad is a consumable part, so it is warranted for a year after it is delivered.

Also, even within the warranty period, the wear of a product due to the use of the vacuum pad or failure due to the deterioration of rubber material are not covered by the limited

warranty.

Compliance Requirements

1. The use of SMC products with production equipment for the manufacture of weapons of mass destruction(WMD) or any other weapon is strictly prohibited.

The exports of SMC products or technology from one country to another are governed by the relevant security laws and regulation of the countries involved in the transaction. Prior to the shipment of a SMC product to another country, assure that all local rules governing that export are known and followed.

Selection



Warning

1. This product is intended for use in general factory automation systems.

If other applications (especially the ones indicated in section 4 above) are used, please contact SMC before use.

2. Use within specified voltage and temperature limits.

Voltage out of specification may cause malfunction, damage, electric shock and/or fire.

3. This product does not have an explosion-proof construction.

Do not use this product in areas where dust explosion might be triggered or where flammable or explosive gas is present. It may cause explosion and/or fire.



Caution

1. This product has not been flushed.

Installation



Warning

1. Install only where there is adequate space for maintenance and wiring.

When installing the electrical connector, ensure sufficient room is left for easy insertion and removal of electrical cable and electrode needles.

Do not install with sharp bends in the cable. With consideration of the minimum bend radii given below, ensure that cable entries are straight, and do not apply stress to the electrical connectors.

If the connectors or fittings are subject to mechanical stress, malfunctions such as broken wires or fire may occur.

2. Install only on a flat surface.

A curved or uneven mounting surface may cause excessive force to be applied to the frame or case. This force, as well as a heavy impact (e.g. from dropping the Ionizer) may result in damage and failure.

3. Do not use in areas subject to electrical noise.

It may cause malfunction, deterioration or damage to internal components. Take measures to prevent noise at source and avoid power and signal lines from coming into close contact.

4. Tighten with the specified torque.

Refer to the following table for the correct tightening torque. If the tightening torque is exceeded the mounting screws and brackets may be broken. If the tightening torque is not reached, the mounting screws and brackets may become loose.

5. Do not touch the electrodes with a finger or metal tool directly. It may cause injury or malfunction.

If the electrodes are touched with a finger, injury or damage may result or if the electrodes are touched with metal tools damage may result. This may interfere with the specified function and performance, but may also cause operational failure or accident.

6. Be sure to install or adjust only after power supply is stopped.



Caution

Be sure to check the effect of static charge removal after installation.

The effectiveness of static charge removal varies depending on the installation and operating conditions.

Wiring and piping



Warning

1. Check the capacity of the power supply is enough and the voltage is within the specified range before wiring.
2. Be sure to use the UL listed power supply specified by NEC (National Electric Code) to be a class 2 output or the limited power source evaluated in accordance with UL 60950.
3. To maintain product performance, and to prevent electrical shock, connect a protective earth in accordance with instructions in this manual. Ensure that the resistance between the lead wire and ground is less than 100Ω.
4. Be sure to turn off the power supply before wiring (including the removal and mounting of the connector).
5. When turning on the power supply, check the wiring and ambient conditions for safety.
6. Do not remove or mount the connector wired to the power supply with the power supply on. Otherwise, the product can malfunction.
7. Be sure to check correct wiring before operating the product. Incorrect wiring may lead to damage to and malfunction of the product.

Environment



Warning

1. Use within ambient temperature range.

The operating fluid and ambient temperature range for Ionizer is 0 to 50°C. In areas where sudden temperature changes occur, even when these changes are within the specified temperature range, condensation may form. The Ionizer should not be used in such conditions.

2. Do not use this product in an enclosed space.

This product utilizes the corona discharge phenomenon. Since this process generates a small amount of ozone and NOx, only use the Ionizer in open, well-ventilated areas.

3. Environments to avoid

Do not use or store under the following conditions, as these may cause equipment failure:

- Ambient temperatures outside the range 0 to 50°C.
- Ambient humidity outside the range 35 to 85% RH.
- Areas where rapid temperature changes may cause condensation.
- Areas where corrosive gas, flammable gas or other volatile flammable substances are stored.
- Areas where the product may be exposed to conductive powder, such as, iron powder or dust, oil mist, salt, organic solvent, machining chips, particles or cutting oil.
- Directly in the path of air conditioners.
- In enclosed, poorly ventilated areas.
- Exposed to the direct sunlight and/or radiant heat.
- Areas where strong electromagnetic noise is generated (strong electric or magnetic fields, large surges).
- Areas where RF noise is generated.
- Areas prone to lightning strikes.
- Areas where the product is directly exposed to vibration and/or impact.
- Subject to weight or mechanical stresses that could cause deformation of the product.

4. Ionizer is not proof against lightning strikes.

Protection against electrical surges due to lightning should be incorporated into the equipment.

Maintenance and Check

Warning

1) Perform maintenance regularly and clean the electrodes.

It is recommended to perform maintenance every week or when the contamination detection LED turns ON. Check regularly that the product is not operating with undetected failures. The maintenance must be carried out by an operator who has sufficient knowledge and experience. If the product is used for a long time and there is dust on the electrodes, the static electricity elimination ability will be reduced. If the electrodes get worn and static electricity elimination ability does not recover even after cleaning, replace the cartridge.



High voltage caution

A high voltage generating circuit is mounted onto this product. Be sure to check that the power supply is stopped when performing maintenance. Never disassemble or renovate the product, as this can cause loss of product functionality, and there is also a risk of electric shock and earth leakage.

2) Cleaning or replacing the electrodes should never be carried out before turning off the power supply to the product.

Fan rotation may cause injury if the power is supplied.
If the electrodes are touched while the product is energized, it may cause an electric shock.

3) Do not disassemble or modify the product.

This may lead to accidents such as electric shock, failure or fire etc. If the product is disassembled and/or modified, the functions and performance in the specifications cannot be achieved and will be outside of the guarantee.

4) Do not operate the product with wet hands.

This can cause an electric shock, etc.

Caution

1) Do not drop, hit or apply excessive shock (10G or more) to the product when handling it.

Even if the ionizer body is not damaged, the inner parts can be damaged, leading to a malfunction.

1. How to Order

1-1. Ionizer

IZF10 - -

Fan type

Air flow

Nil	0.66m ³ /min
L	0.46m ³ /min

Out put

Nil	NPN output
P	PNP output

Bracket

Nil	without Bracket
B	with Bracket

Power supply cable

Nil	with Power supply cable (3m)
Z	with Power supply cable (10m)
H	with e-con connector
Q	with AC adapter, with AC cord
R	with AC adapter, without AC cord
N	None



1-2. Accessory

Power supply cable

IZF10-C

Power supply cable, AC adapter

P	with Power supply cable (3m)
PZ	with Power supply cable (10m)
G1	with AC adapter, with AC cord
G2	with AC adapter, without AC cord

Note) AC cord is Japanese type (rated voltage: 125V)

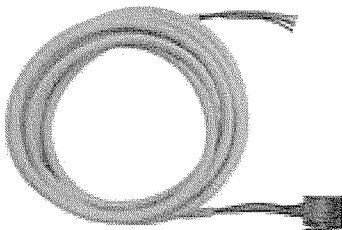

Power supply cable



AC adapter



AC cord

e-con connector

ZS-28-C

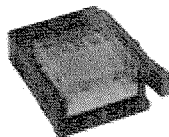

Note) Applicable wire size: AWG26-24, conductor cross sectional area 0.14-0.2mm²
outside diameter (including insulation) Ø0.8-Ø1.0mm.

Bracket

IZF10 – B1

Note) Four retaining bolts are included.

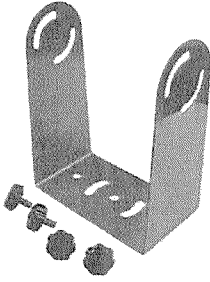

1-3. Maintenance parts

Cartridge case

IZF10 – A1

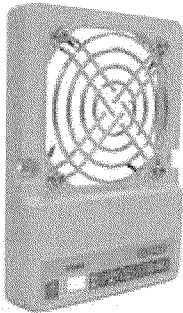

1-4. Option

Electrode needle cleaning kit

IZS30- M2

(Felt, rubber grindstone:
one of each)

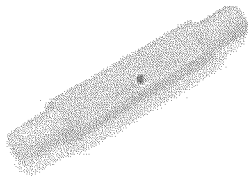

IZS30-A0201

(Felt for replacement 10pcs.)

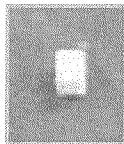

IZS30-A0202

(Rubber grindstone for
replacement one pc.)

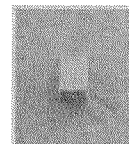

Screwdriver for ion balance adjustment trimmer

IZS30- M1

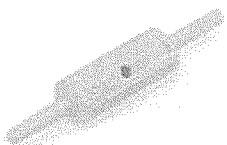

2. Procedure

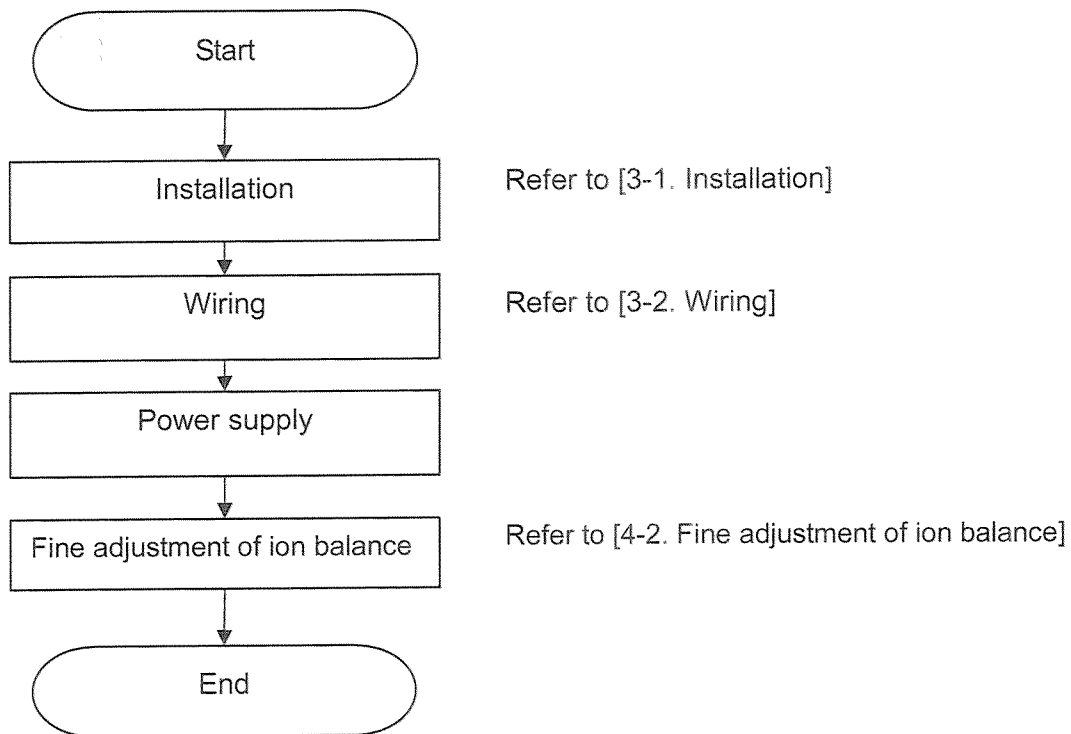

3. Installation and wiring

We recommend investigating environments where static electricity is generated and processes and parts where static electricity disturbance occur in advance, and thoroughly confirming the conditions in order to remove static electricity effectively before installation.

The effect of the ionizer varies depending on the surrounding installation conditions and operating conditions. Confirm the effect of static electricity elimination after installation.

3-1. Installation

3-1-1. Precautions for installation

Do not connect and disconnect connectors while supplying the power. The product may be broken and cause malfunction.

Do not attach tape or seal on the product body. If the tape or seal contains conductive adhesive or reflective paint, it is possible that due to the dielectric effect, charge could build up causing an electro-static discharge or electrical leakage.

When installing the ionizer, ensure the air intake port side of the fan is at least 20mm away from any walls or obstructions. If there is an obstruction of the air intake port, the efficiency will be reduced due to ventilation resistance. Install the ionizer so that the cartridge case can be removed for maintenance and replacement of the electrodes. When the electrodes are cleaned or replaced, remove the two screws mounted on the cartridge case.

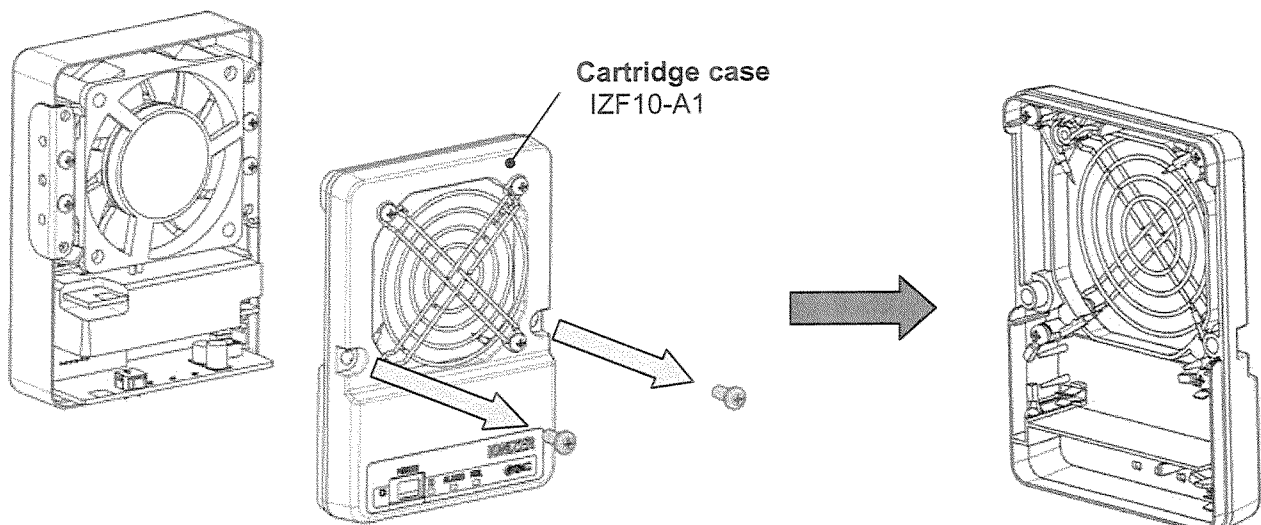

Do not touch the electrodes with a finger or metal tool directly. It may cause injury or malfunction.

If the electrodes are touched with a finger, injury or damage may result or if the electrodes are touched with metal tools damage may result. This may interfere with the specified function and performance, but may also cause operational failure or accident.

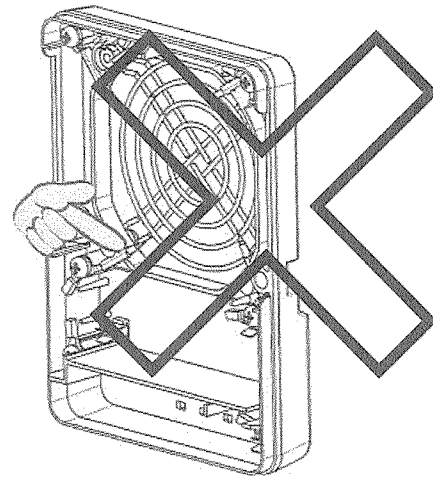
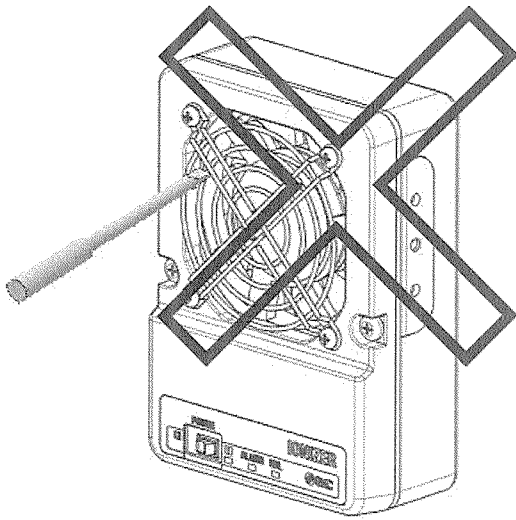

Caution for High Voltage

Do not touch the electrodes.
High voltage is present.

If foreign substances are inserted or persons come into contact with the electrodes, they may be injured by an electric shock or by trying to avoid one.

3-1-2. Mounting

1) Installation with bracket

When installing the ionizer with a bracket, secure it with M5 screws (not supplied) using holes on the bottom of the bracket.

Refer to section 6 Dimensions for details.

The angle adjustment range of the bracket is 50 degrees in direction A and 90 degrees in direction B as shown.

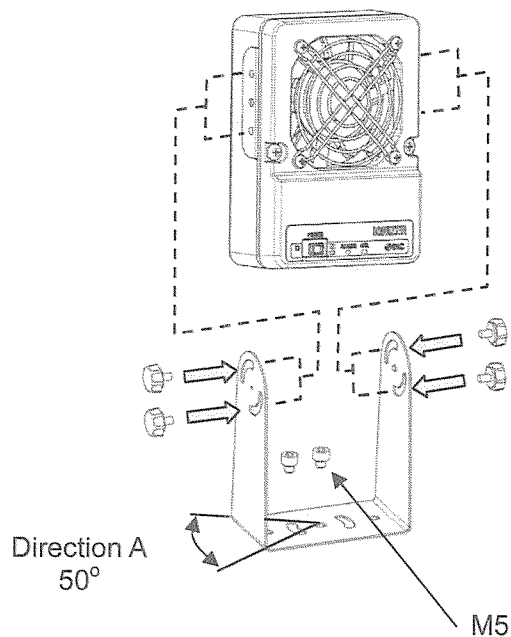
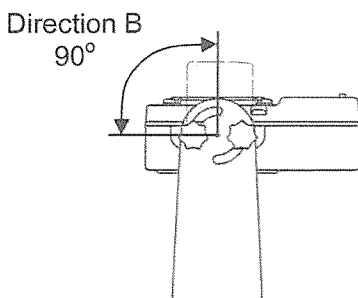

2) Installation without bracket

If a bracket is not used, install the product using the M4 screw holes on the sides of the body.

(Screws are not supplied)

Refer to section 6 Dimensions for details.

M4 screw recommended tightening torque: 1.3 to 1.5Nm.

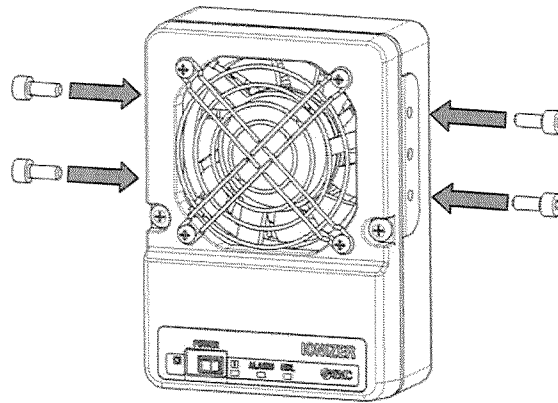

3-2. **Wiring**

3-2-1. **Wiring diagram and Wiring table**

Wire cables according to the circuitry and wiring chart.

Be sure to connect the ground terminal (F.G.) with 100Ω or less.

The ground terminal (F.G.) is used as a reference for the static electricity elimination. If the ground terminal is not connected, it will not be able to gain an appropriate ion balance.

Wiring diagram

NPN output

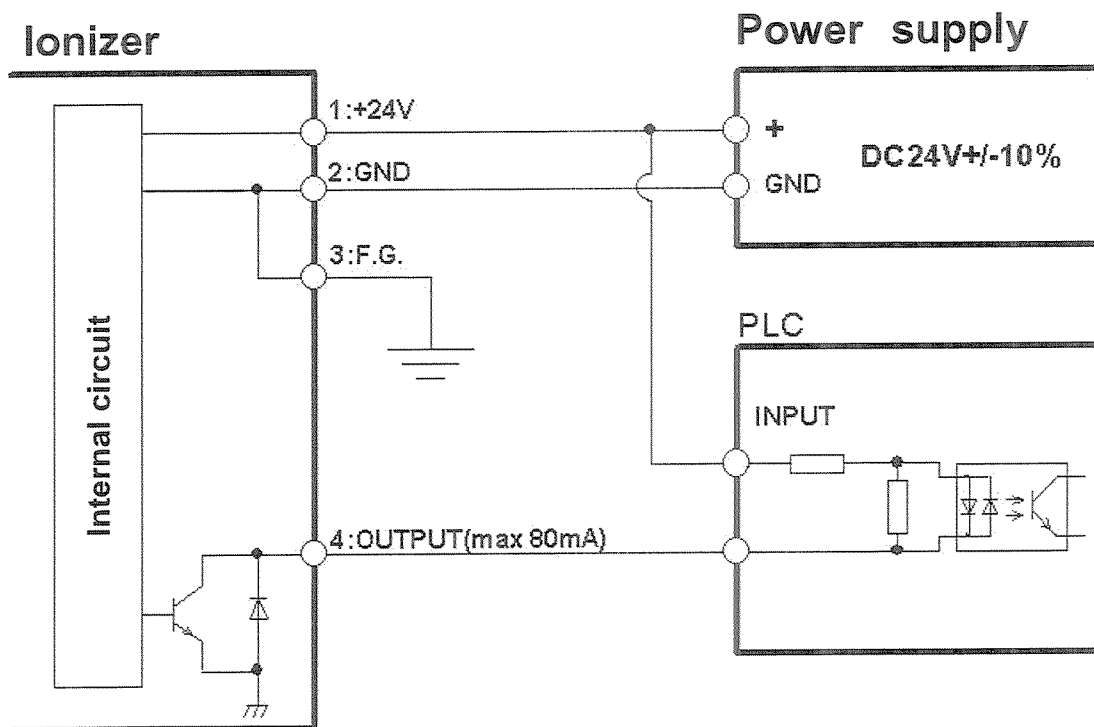

PNP output

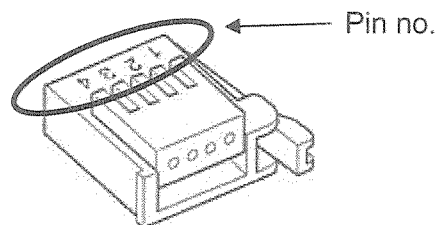
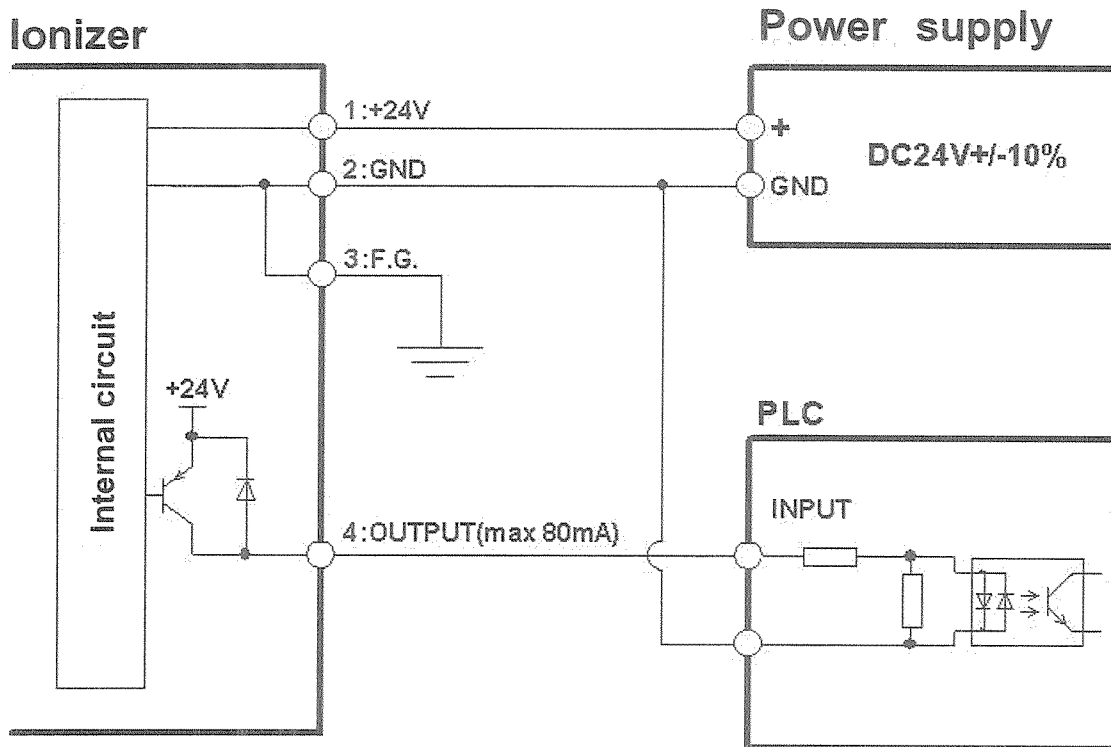

Pin no.	Description	Contents
1	DC+24V	Ionizer driving power supply cable
2	GND	
3	F.G.	Connect to ground with a lead resistance of less than 100Ω. If these connections are not made correctly, the Ionizer may become damaged. Ground reference point for ionizer operation.
4	Error signal	The output turns OFF when any of the errors below occur (normally ON). <ul style="list-style-type: none"> • Incorrect function of high voltage circuit for more than 100ms. • Excess current on the output circuit

3-2-2.Connection cable and connector

1) The connectors are designed to accept wiring between 26 AWG and 24 AWG.

Accept wiring

AWG No.	Wire range mm ²	Outside Diameter mm	Product number
26-24	0.14-0.2	Φ0.8-Φ1.0	ZS-28-C

- 2) Insert each lead wire into the connector.
- 3) After verifying that the wires are fully inserted temporarily hold A down by hand.
- 4) Using pliers, press the center of A straight down.
- 5) Note that that connector cannot be taken apart for reuse once it is crimped. Use a new connector if wiring or cable insertion done incorrectly.

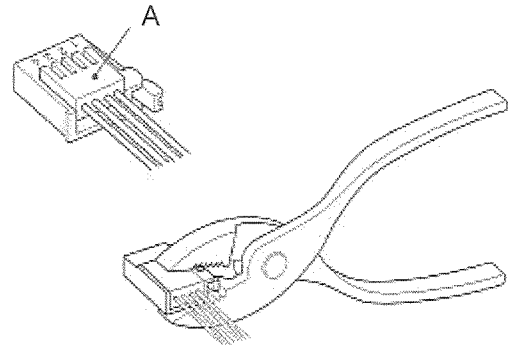

3-2-3. Wiring of the power supply cable

When using the power supply cable, wire it in accordance with the table below.

Pin no.	Cable color	Description
1	Brown	DC+24V
2	Blue	GND
3	Green	F.G.
4	Purple	Error signal

Take the minimum bend radius into consideration when fixing the cable in place to prevent mechanical stress from being applied to the connector.

Minimum bend radius: 10mm

Note) This is the minimum bend radius at 20°C.

Insulate or cut unused electric wires short to prevent possible short circuits.

3-2-4. Wiring of the AC adapter

The green wire on the AC cord must be connected to the ground terminal, F.G. If the ground terminal F.G. is not connected, the ionizer will not be able to achieve the optimal ion balance.

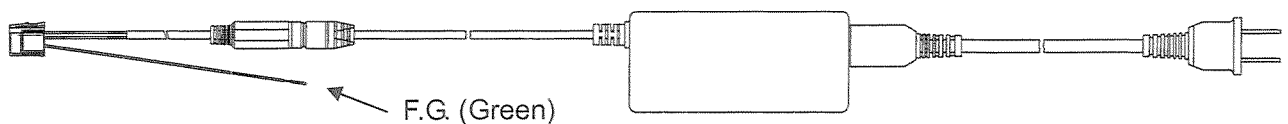

3-3. Timing chart

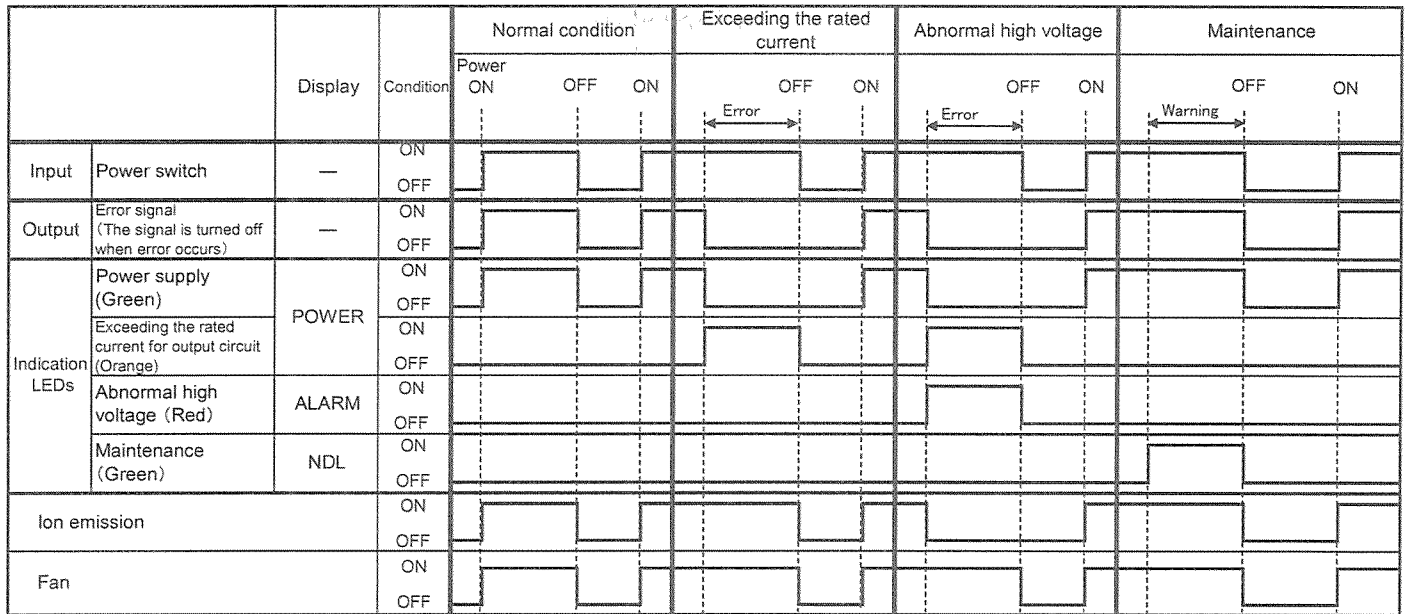

Ensure the power supply is turned off before clearing errors or cleaning the electrodes. If an alarm continues to be generated even after cleaning, the electrodes may be damaged. If the electrodes are damaged, they should be replaced.

4. Functions

4-1. Description of components

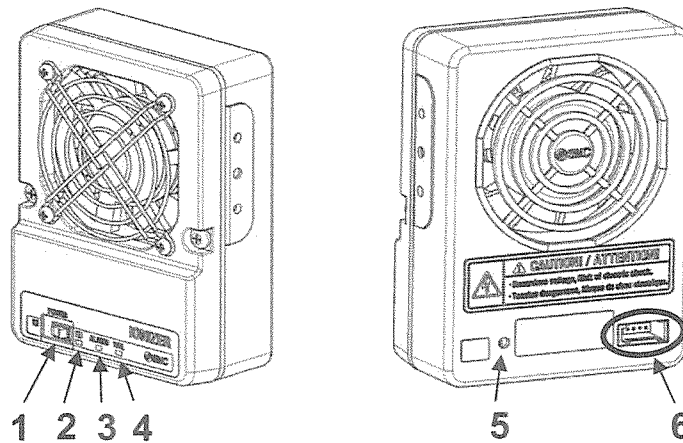

NO.	Name	Type	Description
1	Power switch	Switch	Turns the ionizer on and off.
2	Power supply indicator	LED(Green, Orange)	Turns ON (green) when power is supplied. Turns ON (orange) if there is a high voltage error or excess current on the output.
3	Indicator for abnormal high voltage	LED(Red)	Turns ON if incorrect function of high voltage circuit for more than 100ms.
4	Maintenance	LED(Green)	Turns ON when electrodes require cleaning.
5	Ion balance adjusting trimmer	Trimmer	This trimmer is used to adjust the ion balance. Refer to [4-2. Fine adjustment of ion balance]
6	Connector	connector	Power supply, F.G. , Output signal

4-2. Fine adjustment of ion balance

The ion balance of the ionizer is adjusted before shipment. However, readjustment might be required depending on the installed environment, so fine adjustment can be performed.

Use a trimmer for balance fine adjustment to perform fine adjustment of the ion balance. When performing fine adjustment of the ion balance, use a measuring instrument such as a charged plate monitor.

Rotating the trimmer for fine adjustment clockwise increases the positive ions, and rotating it counterclockwise increases the negative ions.

4-3. Detection and cleaning of contamination on the electrodes

If the ionizer is used for a long time, dust can adhere to the electrodes, reducing the static electricity elimination performance.

This product has a function whereby an LED indicates when the electrodes are contaminated.

The electrodes should be cleaned when contamination is detected, or once a week.

Clean the electrodes with the electrode cleaning kit [IZS30-M2] or a cotton bud soaked in alcohol. (The cleaning period varies depending on the environment where the ionizer is installed. The cleaning cycle is stated here as a guideline only.)

Turn off the power supply before cleaning the electrodes. Fan rotation may cause injury if power is supplied.

If an electrode is touched while the power is supplied, an electric shock or accident may occur. Also, the end of the electrode is sharp, so touching it may cause an injury.

If the ionizer performance does not recover after cleaning the electrodes, it can be assumed that the electrodes are damaged or worn out. If the electrodes are damaged or worn out, the electrodes or cartridge case need to be replaced.

-Mounting/removal and cleaning of cartridge case -

- 1) Turn off the power supply of the ionizer.
- 2) Remove the 2 screws as shown in the figure below and remove the cartridge case.

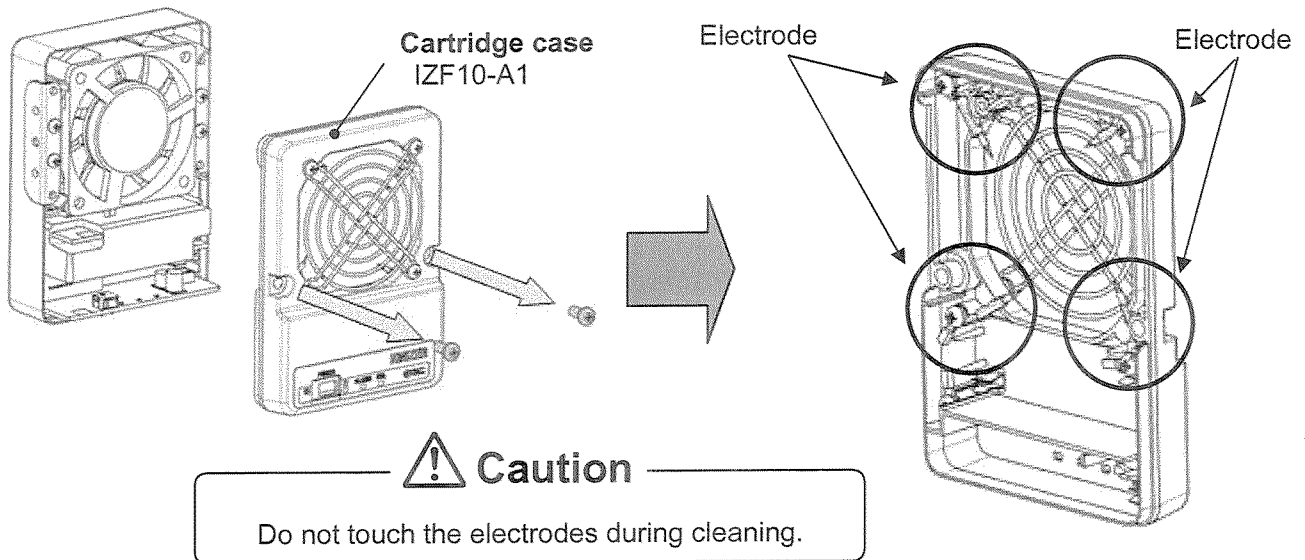

- 3) Four electrodes are fixed inside the removed cartridge case. Clean the ends of the electrodes.

Using the cleaning kit, saturate the felt with industrial alcohol, insert it into the electrodes and rotate several times to clean. If the contamination does not come off, use the rubber grindstone to clean the electrodes in the same way.

After that, again use the felt saturated with industrial alcohol to finish the cleaning.

If a cleaning kit is not available, saturate a cotton bud with alcohol to clean the electrodes.

The industrial alcohol used should be reagent ethanol class 1 99.5vol% or greater.

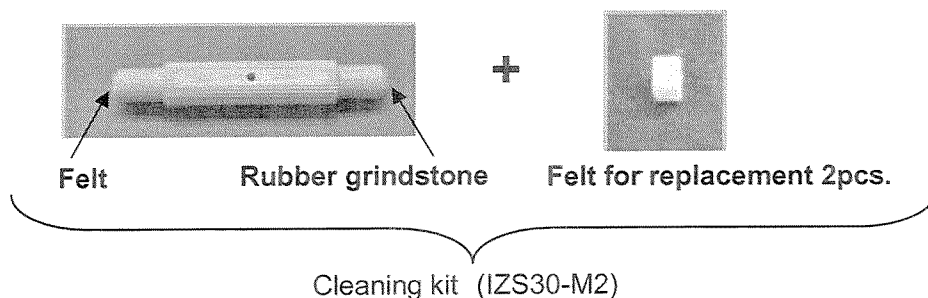

The cleaning kit has felt and rubber grindstones on the ends. Choose the felt or rubber grindstone depending on the level of contamination to effectively clean the electrodes.

Felt: Use for normal cleaning

Rubber: Use if contamination is hard and stuck to the electrodes and it is not possible to remove it with felt.

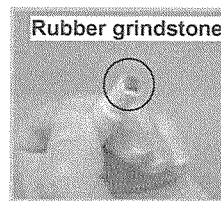
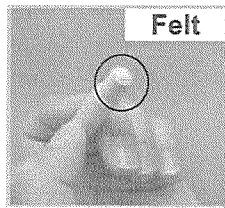

- 4) Put the cartridge case back in its original position by reversing the removal procedure. Take care not to get the cable caught in the cartridge case when remounting. (Recommended tightening torque: 0.7 to 0.8Nm)

4-4. Replacement of the cartridge case

If the electrodes are worn out or damaged, replace the cartridge case.

Remove the screws and replace them as shown in the figure below.

(Recommended tightening torque: 0.7 to 0.8Nm)

Take care not to get the cable caught in the enclosure when remounting.

If replacing the electrodes only, contact your SMC representative.

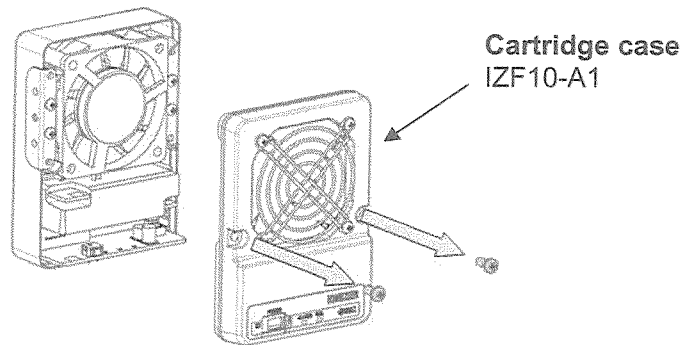

4-5 Alarm function

If abnormal functioning occurs during operation of the ionizer, the user is alerted by the external output signal or LED operation.

Alarm	Output Note1)	LED	Ion generation during alarm	Fan rotation during alarm	Contents	How to clear error indication after problems are solved.
Exceeding the rated current for output circuit	The signal is turned off when error occurs.	POWER (Orange)	Continues	Continues	Excess current is present on the output circuit and protection circuit is activated.	Turn power off then on again.
Abnormal high voltage	The signal is turned off when error occurs.	POWER (Orange) ALARM (Red)	Stop	Continues	Incorrect function of high voltage circuit for more than 100ms.	Turn power off then on again.
Maintenance	-	NDL (Green)	Continues	Continues	The static electricity elimination performance is reduced due to contamination, wear or damage to the electrodes.	-

Note 1) NPN/PNP open collector output

- 1) Excess current present on the output circuit.

If excess current is present on the output circuit, the output is shut off to protect the circuit.

In this situation, the ionizer operation continues.

In order to clear the alarm, reduce the load on the output circuit to 80mA or less and supply the power again.

- 2) Incorrect high voltage function.

If an abnormal discharge from the electrodes continues for more than 100ms when the ionizer is operated, the ion generation will stop.

In this situation, the fan will not stop.

An abnormal discharge could be caused by condensation or dust on the electrodes.

In order to clear the alarm, remedy the cause of the abnormal discharge and supply the power again.

3) Maintenance

If the electrodes become contaminated, worn out or damaged, the LED will turn ON.
 If the electrodes are contaminated, they can be cleaned, but if they are worn out or damaged, the cartridge case will have to be replaced.
 The ionizer will continue to operate after the alarm.

5. Electricity Removal Characteristics

Static electricity elimination features are based on the data using the charged plate (size:150mm X 150mm,capacitance:20pF) as defined in the U.S.ANSI standards (ANSI/ESD,STM3,1-2006).Use this as a guideline purpose only for model selection because the value depending on the material and/or size of a subject.

• Discharge time from 1000V to 100V

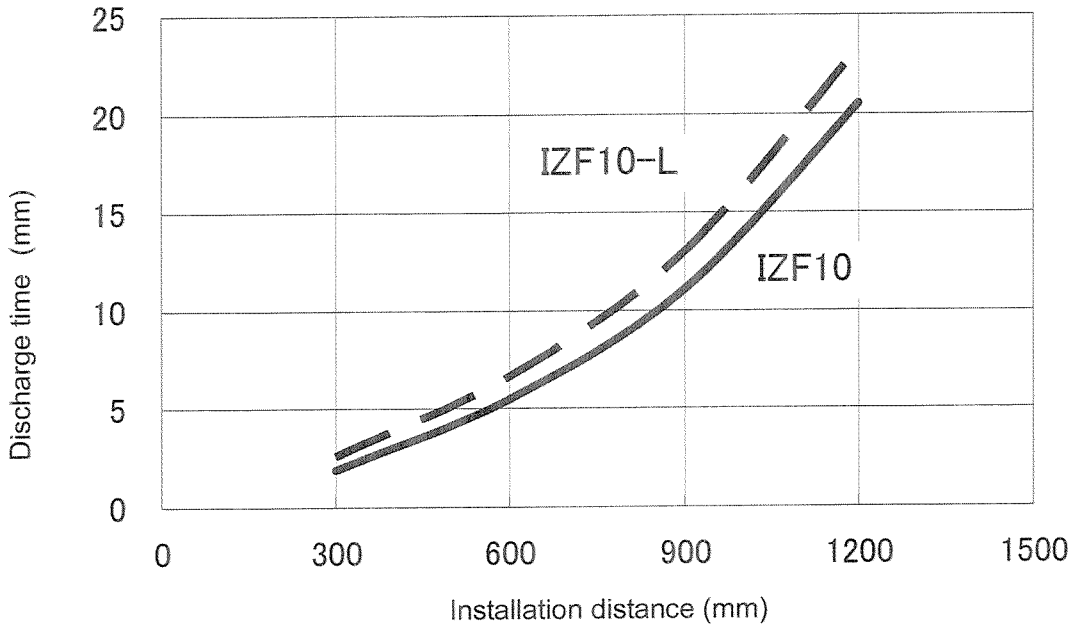

• Static electricity elimination range

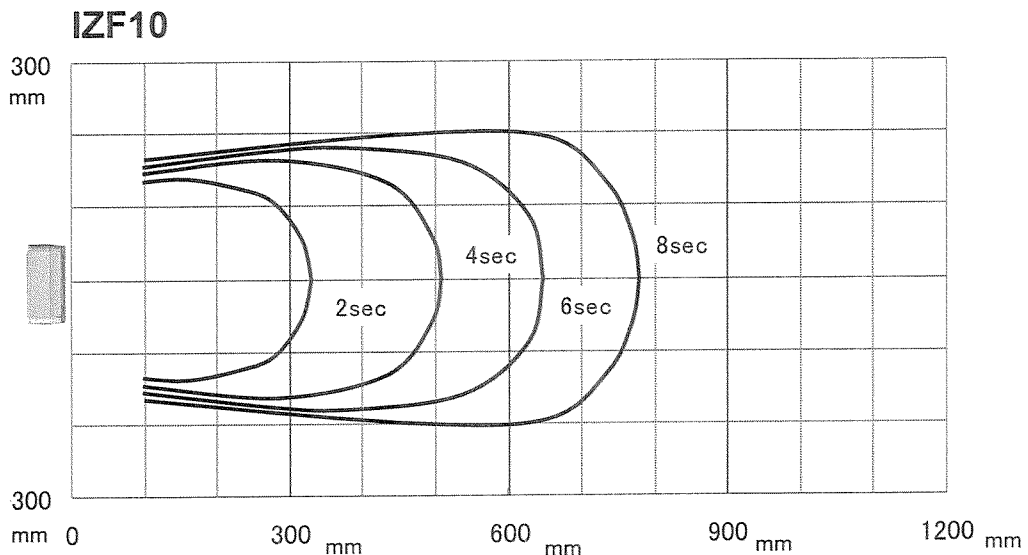

IZF10-L

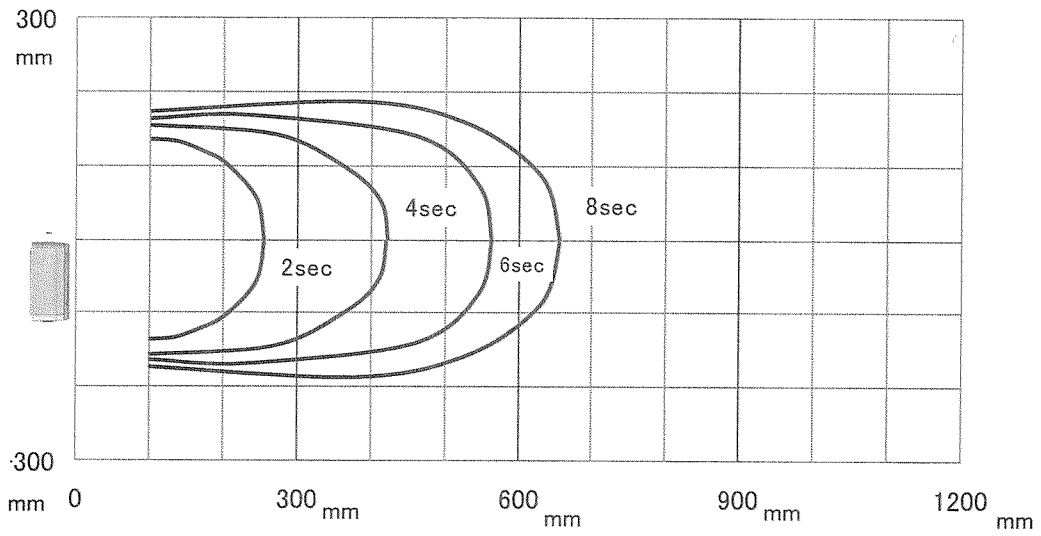

6. Dimensions

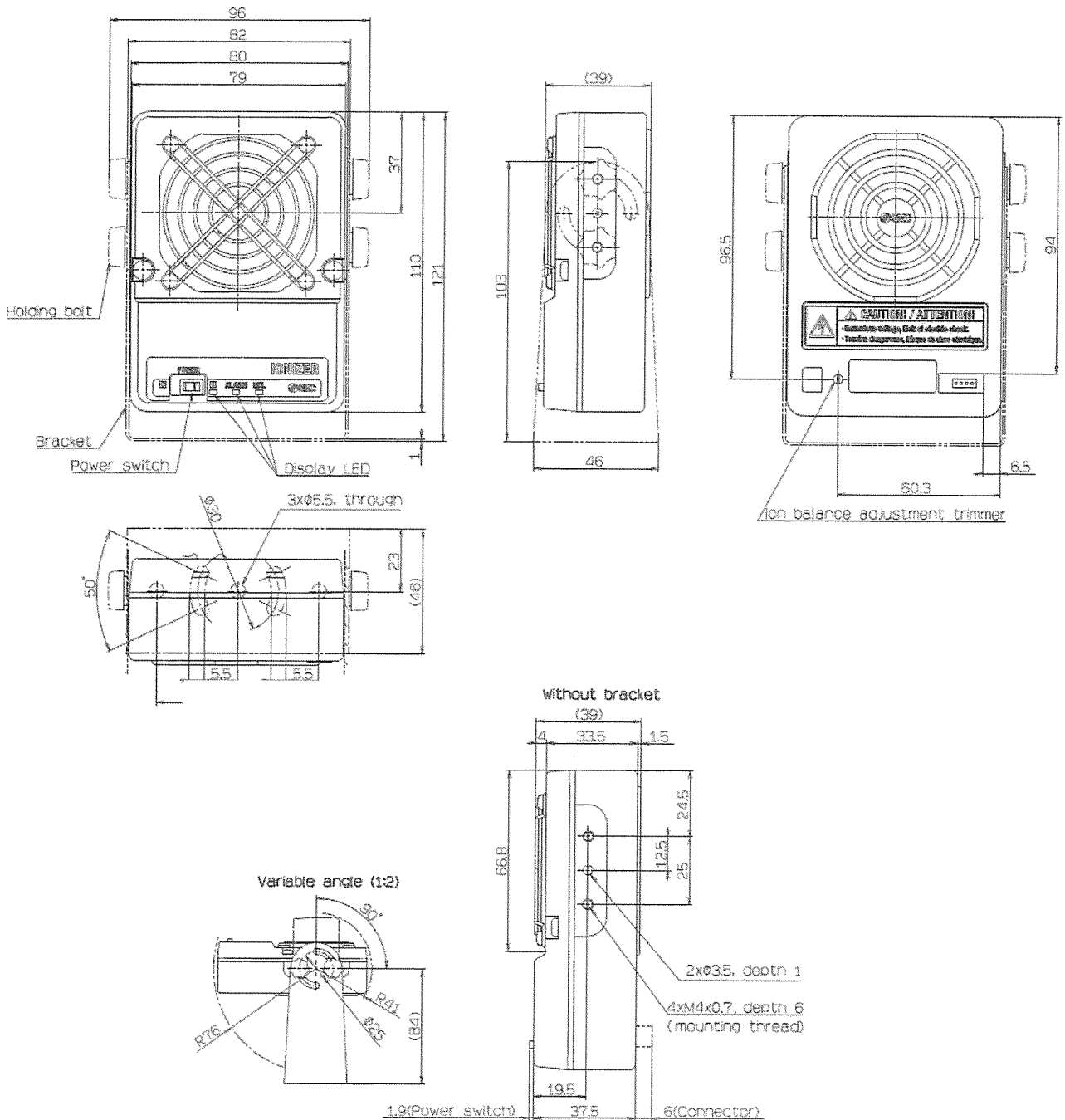

Power supply cable

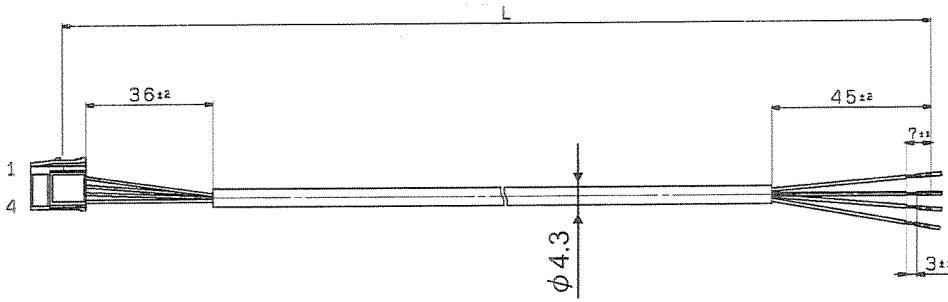

Part No.	L
IZF10-CP	3000 ⁺⁶⁰ ₀
IZF10-CPZ	9850 ⁺¹⁰⁰ ₀

Pin no.	Cable color	Description
1	Brown	DC+24V
2	Blue	GND
3	Green	F.G.
4	Purple	Error signal

AC adapter

IZF10-CG1 (with AC code)

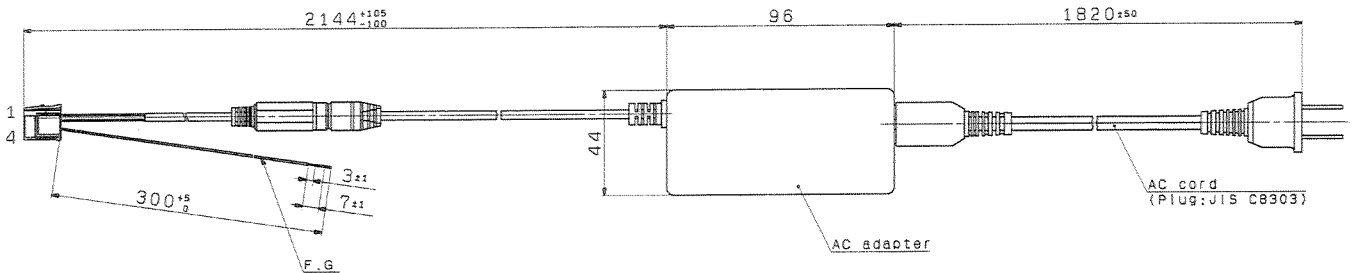

IZF10-CG2 (without AC code)

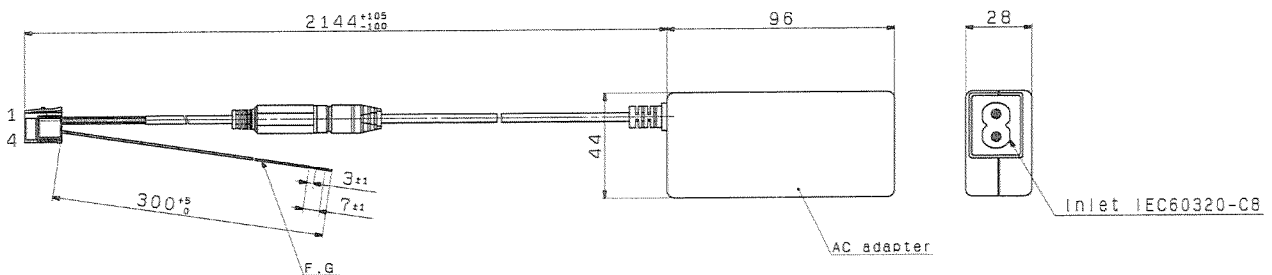

Part No.	AC cord
IZF10-CG1	with AC cord
IZF10-CG2	without AC cord

7. Specifications

Ionizer model	IZF10-□□	IZF10-L-□□	IZF10-P-□□	IZF10-LP-□□
Air flow	0.66m ³ /min	0.46m ³ /min	0.66m ³ /min	0.46m ³ /min
Ion generation method	Corona discharge type			
Voltage applying method	DC			
Discharge output Note1)	+/-5kV			
Ion balance Note2)	+/-13V or less			
Power supply voltage	DC24V+/-10 (%)			
Power consumption	6.1W or less	3.7W or less	6.6W or less	4.7W or less
Switch output	NPN open collector output Maximum load current: 80mA Residual voltage: 1V or less (Load current 80mA) Maximum load voltage:DC26.4V		PNP open collector output Maximum load current: 80mA Residual voltage: 1V or less (Load current 80mA)	
Ambient temp	Operating: 0 to 50°C、Stored: -10 to 60°C			
Ambient humidity	Operating、Stored: 35 to 80%RH(no condensation)			
Material	Ionizer cover: ABS, Stainless Electrode needle: Tungsten			
Vibration resistance	10 to 55Hz at the smaller of amplitude 1.5mm or acceleration 98m/s ² in X, Y, Z direction for 2hrs. each (De-energized)			
Impact resistance	10G			
Weight	280g(with Bracket 360g)			
Standard	CE(EMC directive 2004/108/EC)			

Note1) This is the value when measured by a probe with 1,000 MΩ and 5 pF.

Note2) Static electricity elimination features are based on the data using the charged plate (size:150mm X 150mm,capacitance:20pF) as defined in the U.S.ANSI standards (ANSI/ESD,STM3,1-2006). This value when the distance between the charged object and an ionizer is 300mm.

AC adapter (IZF10-CG1 / IZF10-CG2)

Input voltage	AC100V-240V、50/60Hz
Output voltage	DC24V
Output current	1A max
Ambient temp	Operating: 0 to 40°C、Stored: -20 to 65°C
Ambient humidity	Operating、Stored: 10 to 90%RH
Standard	CE、UL、cUL

Revision history

SMC Corporation

4-14-1, Sotokanda, Chiyoda-ku, Tokyo 101-0021 JAPAN
Tel: + 81 3 5207 8249 Fax: +81 3 5298 5362
URL <http://www.smcworld.com>

Note: Specifications are subject to change without prior notice and any obligation on the part of the manufacturer.
© 2008 SMC Corporation All Rights Reserved