

Floating Joint: Heavy Load Type

Series JAH

Specifications

Operating pressure	Hydraulic cylinder: 7 MPa or less
Mounting	Basic style, Flange style, Foot style

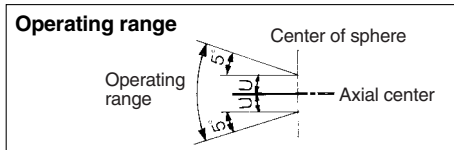

Series JAH



Series JAHL
(Foot style)



Series JAHF
(Flange style)

Specifications

Model	Applicable bore size (mm)	Applicable cylinder nominal thread size	Maximum operating tension and compression force (N)			Allowable eccentricity U (mm)	Rotating angle	
			Basic style	Flange style	Foot style			
Standard/Thread nominal size								
JAH□40-16-150	40	M16 x 1.5	11000	9000	9000	1.25	±5°	
JAH□50-20-150	50	M20 x 1.5	18000	14000	14000	2		
JAH□63-24-150	63	M24 x 1.5	28000	22000	22000	2		
JAH□80-30-150	80	M30 x 1.5	54000	36000	36000	2.5		
JAH□100-39-150	100	M39 x 1.5	71000	55000	55000	3		
JAH□100-48-150	100	M48 x 1.5	71000	55000	55000	3	±5°	
Option/Thread nominal size								
JAH□63-24-200	63	M24 x 2	28000	22000	22000	2		
JAH□80-30-200	80	M30 x 2	54000	36000	36000	2.5	±5°	
JAH□100-42-300	100	M42 x 3	71000	55000	55000	3		

How to Order

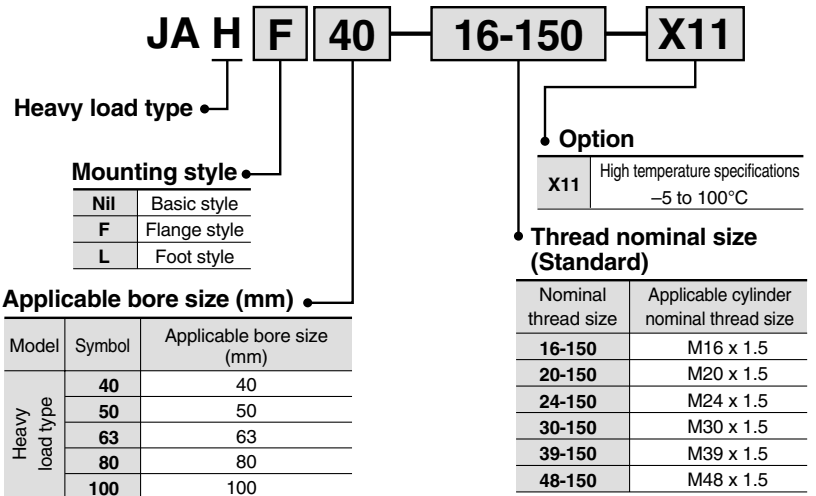

⚠ Precautions

Be sure to read before handling. Refer to pages 10-24-3 to 10-24-6 for Safety Instructions and Actuator Precautions.

Mounting

⚠ Warning

- To screw the male threads of the rod into the female threads of the socket or the case, make sure that it does not bottom out. If the floating joint is used with its rod bottomed out, the stud will not be able to float, causing damage. For the screw-in depth of the female threads, refer to the dimensions (page 10-19-8). As a rule, after the rod bottoms out, back off 1 to 2 turns.

- When screwing stud or socket, or case in the driven object, make sure to screw them in the state that dust cover has been removed from the case. If screwing without removing dust cover, duct cover might be broken.
- To use a floating joint to connect the cylinder rod to a driven body, secure it in place by applying a torque that is appropriate for the thread size. Also, if there is a risk of loosening during operation, take measures to prevent loosening, such as using a locking pin or thread adhesive.
In the event that the connected portion becomes loose, the driven body might lose control or fall off, leading to equipment damage or injury to personnel.

- Do not use for rotational applications, because it is not a fitting designed for rotational axis.

Maintenance

⚠ Warning

- Do not reuse if disassembled. High strength adhesive is applied to the portion of the connection that is threaded to prevent it from loosening, and it must not be disassembled. If it is forcefully disassembled, it could lead to damage.

Series JAH

Construction

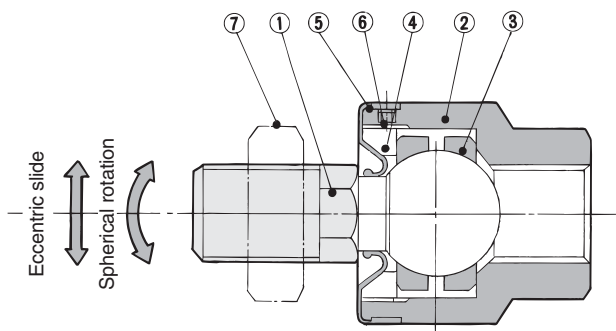

Component Parts

No.	Description	Material	Note
①	Stud	Chromium molybdenum steel	
②	Case	Carbon steel	
③	Ring	Chromium molybdenum steel	
④	Cap	Carbon steel	
⑤	Dust cover	Synthetic rubber	
⑥	Set screw	Carbon steel	
⑦	Rod end nut	Carbon steel	
⑧	Flange	Rolled steel plate	
⑨	Foot	Rolled steel plate	

Basic Style: JAH

JAH40 to 100

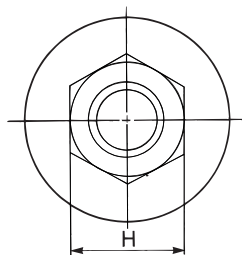
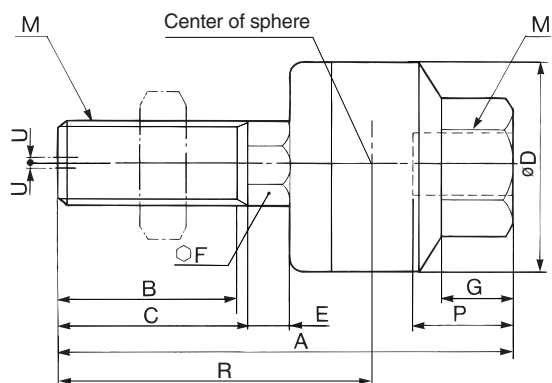

Without C-dimension

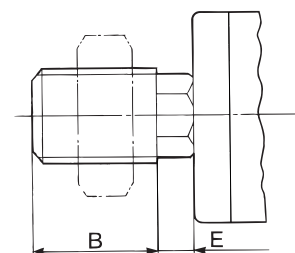

Applicable bore size (mm)	Model	M		A	B	C	D	E	F	G	H	Center of sphere R	Maximum thread depth P	Allowable eccentricity U	Maximum operating tension and compression force (N)	Weight (kg)
		Nominal size	Pitch													

Standard: Heavy Load Type Hydraulic: Up to 7 MPa

40	JAH40-16-150	16	1.5	85.5	22	25	50	9.5	19	16	32	52.5	18	1.25	11000	0.58
50	JAH50-20-150	20	1.5	101	28	31	59.5	11.5	24	16	32	64	18	2	18000	1.08
63	JAH63-24-150	24	1.5	120	32	35	66	13	27	20	41	74	24	2	28000	1.5
80	JAH80-30-150	30	1.5	152	42	45	79	14	30	22	46	94.5	38	2.5	54000	2.7
100	JAH100-39-150	39	1.5	178	52	55	96	16	36	24	55	112	42	3	71000	4.8
100	JAH100-48-150	48	1.5	191	61	—	96	16	36	29	70	118	49	3	71000	5.4

Option: Heavy Load Type Hydraulic: Up to 7 MPa

63	JAH63-24-200	24	2	120	31	35	66	13	27	20	41	74	24	2	28000	1.5
80	JAH80-30-200	30	2	152	41	45	79	14	30	22	46	94.5	38	2.5	54000	2.7
100	JAH100-42-300	42	3	178	55	—	96	16	36	24	55	112	42	3	71000	4.8

Flange Style: JAFH

JAFH40 to 100

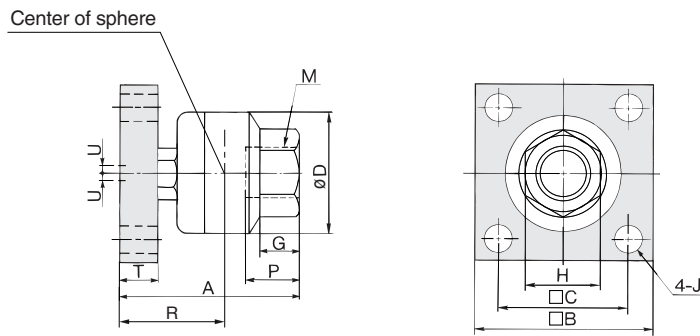

Applicable bore size (mm)	Model	M		A	B	C	D	T	J	G	H	Center of sphere R	Maximum thread depth P	Allowable eccentricity U	Maximum operating tension and compression force (N)	Weight (kg)
		Nominal size	Pitch													

Standard: Heavy Load Type Hydraulic: Up to 7 MPa

40	JAHF40-16-150	16	1.5	76	75	50	50	15	11	16	32	43	18	1.25	9000	1.25
50	JAHF50-20-150	20	1.5	89	100	62	59.5	18	14	16	32	52	18	2	14000	2.5
63	JAHF63-24-150	24	1.5	106	100	72	66	21	18	20	41	60	24	2	22000	2.8
80	JAHF80-30-150	30	1.5	131	125	82	79	24	18	22	46	73.5	38	2.5	36000	5.2
100	JAHF100-39-150	39	1.5	152	150	100	96	29	22	24	55	86	42	3	55000	9
100	JAHF100-48-150	48	1.5	159	150	100	96	29	22	28	70	86	49	3	55000	9.3

Option: Heavy Load Type Hydraulic: Up to 7 MPa

63	JAHF63-24-200	24	2	106	100	72	66	21	18	20	41	60	24	2	22000	2.8
80	JAHF80-30-200	30	2	131	125	82	79	24	18	22	46	73.5	38	2.5	36000	5.2
100	JAHF100-42-300	42	3	152	150	100	96	29	22	24	55	86	42	3	55000	9

Foot Style: JAHL

JAHL40, 50

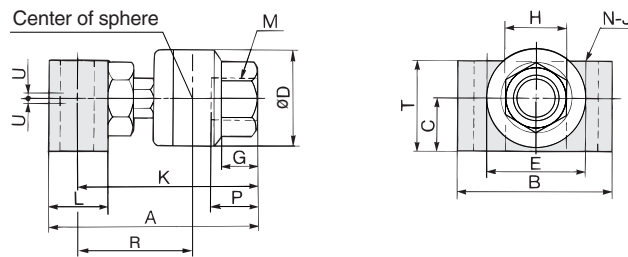

JAHL63 to 100

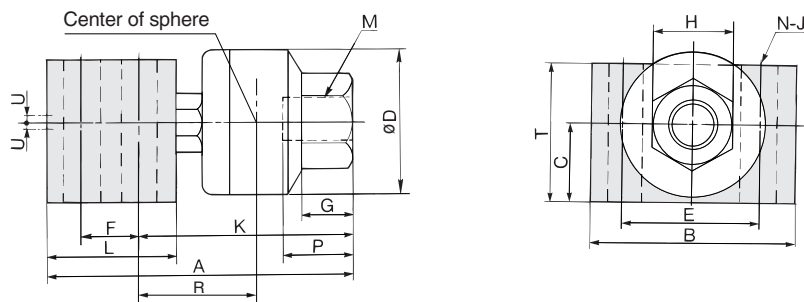

Applicable bore size (mm)	Model	M		A	B	C	D	E	F	K	L	T	N	J	G	H	Center of sphere R	Maximum thread depth P	Allowable eccentricity U	Maximum operating tension and compression force (N)	Weight (kg)
		Nominal size	Pitch																		

Standard: Heavy Load Type Hydraulic: Up to 7 MPa

40	JAHL40-16-150	16	1.5	98.5	70	28	50	42	—	86	25	47	2	14	16	32	53	18	1.25	9000	1.09
50	JAHL50-20-150	20	1.5	123	80	35	59.5	48	—	107	32	58	2	16	20	41	65	24	2	14000	2.03
63	JAHL63-24-150	24	1.5	155	88	38	66	54	36	102	70	69	4	18	20	41	56	24	2	22000	4.1
80	JAHL80-30-150	30	1.5	187	96	45	79	60	44	125	80	79	4	18	22	46	67.5	38	2.5	36000	6.4
100	JAHL100-39-150	39	1.5	213	116	55	96	74	48	144	90	89	4	22	24	55	78	42	3	55000	10
100	JAHL100-48-150	48	1.5	220	116	55	96	74	48	151	90	89	4	22	28	70	78	49	3	55000	10.5

Option: Heavy Load Type Hydraulic: Up to 7 MPa

63	JAHL63-24-200	24	2	155	88	38	66	54	36	102	70	69	4	18	20	41	56	24	2	22000	4.1
80	JAHL80-30-200	30	2	187	96	45	79	60	44	125	80	79	4	18	22	46	67.5	38	2.5	36000	6.4
100	JAHL100-42-300	42	3	213	116	55	96	74	48	144	90	89	4	22	24	55	78	42	3	55000	10

 RE^A_B

REC

C□X

C□Y

 MQ^Q_M

RHC

MK(2)

 RS^Q_G

 RS^H_A

RZQ

 MI^W_S

CEP1

CE1

CE2

ML2B

 C¹/₅-S

CV

MVGQ

CC

RB

J

D-

-X

20-

Data