

Compact Guide Cylinder

Ø 12, Ø 16, Ø 20, Ø 25, Ø 32, Ø 40, Ø 50, Ø 63, Ø 80, Ø 100

RoHS

Compact

• Port thread types **G, Rc, NPT.**

Overall length shortened

Height shortened

JMGP Ø 32

JMGP Ø 32

25 mm stroke



30.5 mm



16 mm

Current product Ø 32

Current product Ø 32

Weight **Max. 69% lighter**

0.32 kg → 0.1 kg

(Compared with the current MGP-Z series, Ø 16, 10 mm stroke)



• Suitable for pushing, lifting or clamping in a transport line.

JMGP Series

SMC

CAT.EUS20-238C-UK

Compact

Height (Compared with the current product (MGP-Z))

Bore size [mm]	Current product MGP-Z [mm]	JMGP [mm]	Current product CXS [mm]
Ø 12	26 →	17	17* ¹
Ø 16	30 →	18	20* ²
Ø 20	36 →	22	25
Ø 25	42 →	26	30
Ø 32	48 →	32	38
Ø 40	54 →	41	—
Ø 50	64 →	51	—
Ø 63	78 →	56	—
Ø 80	91.5 →	69	—
Ø 100	111.5 →	84	—

*1: Bore size 10 *2: Bore size 15

Overall length (Compared with the current product (MGP-Z))

Bore size - Stroke [mm]	Current product MGP-Z [mm]	JMGP [mm]	Current product CXS [mm]
Ø 12-10 stroke	52 →	43	82* ¹
Ø 16-10 stroke	56 →	43	89* ²
Ø 20-20 stroke	73 →	58	114
Ø 25-20 stroke	73.5 →	59.5	116
Ø 32-25 stroke	100 →	69.5	137
Ø 40-25 stroke	100 →	79	—
Ø 50-25 stroke	113.5 →	88	—
Ø 63-25 stroke	113.5 →	92.5	—
Ø 80-25 stroke	129.5 →	110.5	—
Ø 100-25 stroke	151.5 →	119.5	—

*1: Bore size 10 *2: Bore size 15

Internal structure

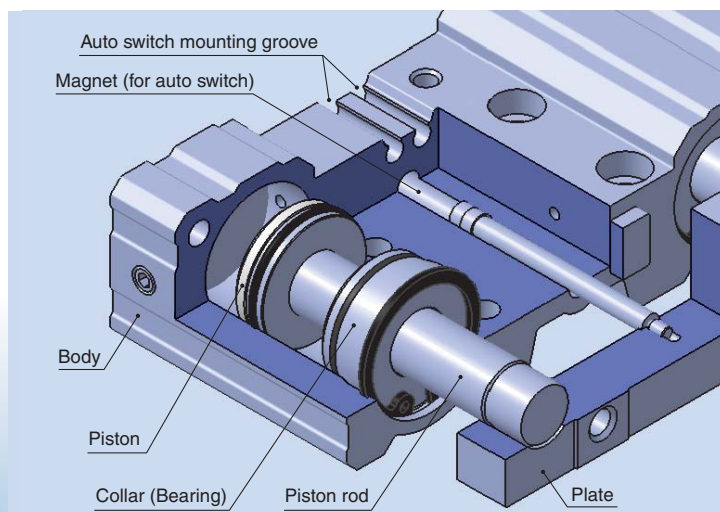

Height



- Suitable for pushing, lifting or clamping in a transport line.

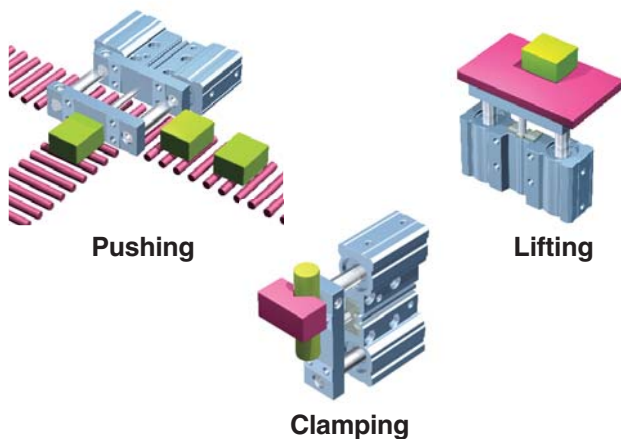

Piping is possible in 4 directions.

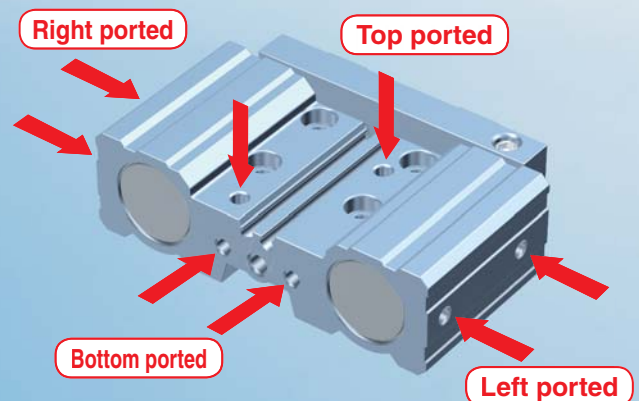



Lightweight

Weight (Compared with the current product (MGP-Z))

Bore size - Stroke [mm]	Current product MGP-Z [kg]	JMGP [kg]	Current product CXS [kg]
Ø 12-10 stroke	0.22 →	0.09	0.15 ^{*1}
Ø 16-10 stroke	0.32 →	0.10	0.25 ^{*2}
Ø 20-20 stroke	0.59 →	0.21	0.44
Ø 25-20 stroke	0.84 →	0.28	0.66
Ø 32-25 stroke	1.41 →	0.60	1.28
Ø 40-25 stroke	1.64 →	0.80	—
Ø 50-25 stroke	2.79 →	1.27	—
Ø 63-25 stroke	3.48 →	1.60	—
Ø 80-25 stroke	5.41 →	2.81	—
Ø 100-25 stroke	9.12 →	4.48	—

*1: Bore size 10 *2: Bore size 15

The solid state auto switch D-M9□ is mountable.

Overall length

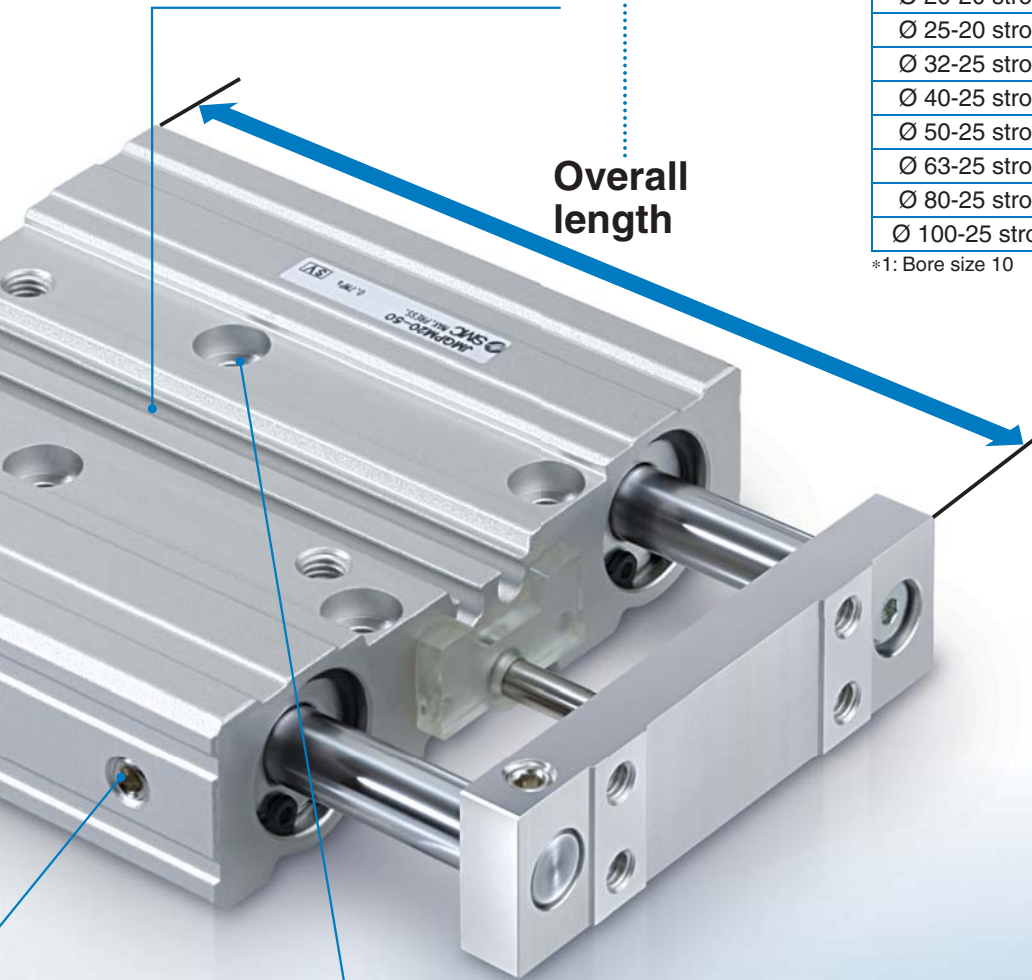

3 mounting options

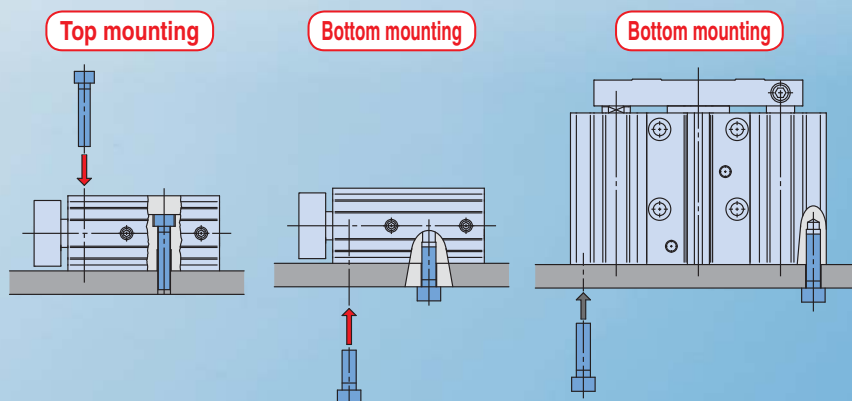

Compact Guide Cylinder

JMGP Series

∅ 12, ∅ 16, ∅ 20, ∅ 25, ∅ 32, ∅ 40, ∅ 50, ∅ 63, ∅ 80, ∅ 100

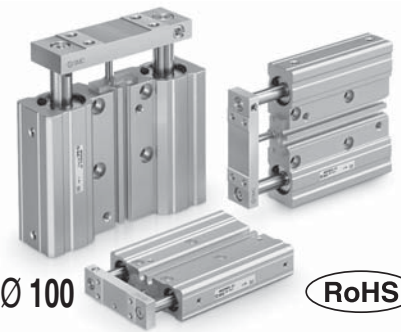

RoHS

How to Order

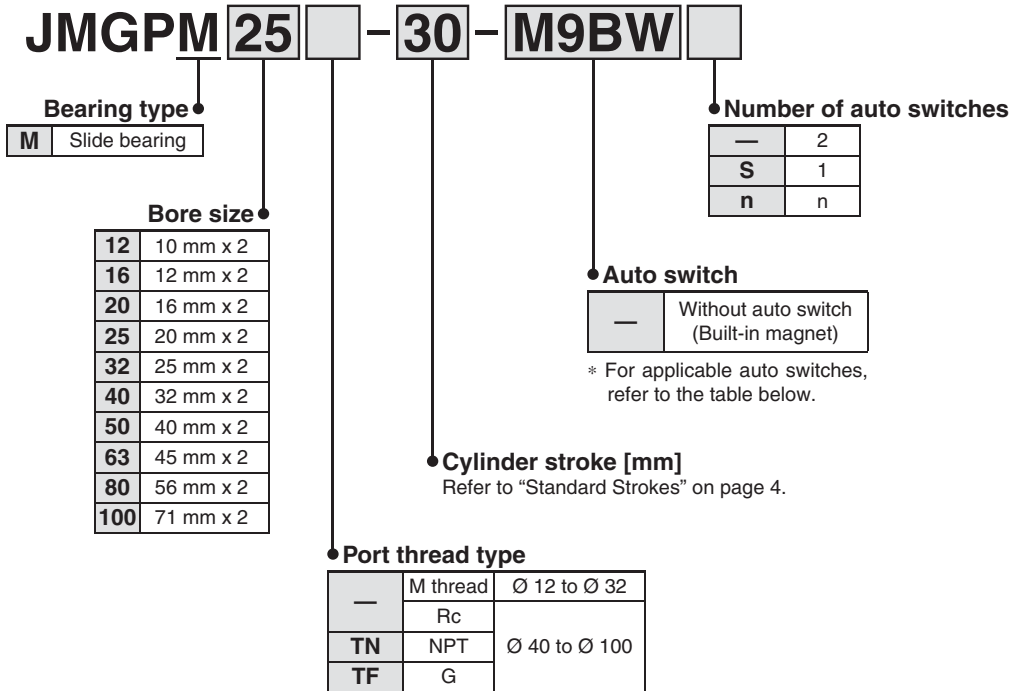

Applicable Auto Switches/Refer to the Auto Switch Guide for further information.

Type	Special function	Electrical entry	Indicator light	Wiring (Output)	Load voltage		Auto switch model		Lead wire length [m]				Pre-wired connector	Applicable load	
					DC	AC	Perpendicular	In-line	0.5 (—)	1 (M)	3 (L)	5 (Z)			
Solid state auto switch	—	Grommet	Yes	3-wire (NPN)	24 V	—	M9NV	M9N	●	●	●	○	○	IC circuit	
				3-wire (PNP)			M9PV	M9P	●	●	●	○	○		
				2-wire			M9BV	M9B	●	●	●	○	○		
	Diagnostic indication (2-colour indicator)			3-wire (NPN)	24 V	—	M9NWV	M9NW	●	●	●	○	○	○	IC circuit
				3-wire (PNP)			M9PWV	M9PW	●	●	●	○	○		
				2-wire			M9BWV	M9BW	●	●	●	○	○		
	Water resistant (2-colour indicator)			3-wire (NPN)	24 V	—	M9NAV**	M9NA**	○	○	●	○	○	○	IC circuit
				3-wire (PNP)			M9PAV**	M9PA**	○	○	●	○	○		
				2-wire			M9BAV**	M9BA**	○	○	●	○	○		
				—			—	—	—	—	—	—	—	—	

** Water resistant type auto switches can be mounted on the above models, but in such case SMC cannot guarantee water resistance. Please contact SMC regarding water resistant types with the above model numbers.

* Lead wire length symbols: 0.5 m..... — (Example) M9NW * Solid state auto switches marked with "○" are produced upon receipt of order.
 1 m..... M (Example) M9NWM
 3 m..... L (Example) M9NWL
 5 m..... Z (Example) M9NWZ

* For details about auto switches with pre-wired connector, refer to the **Auto Switch Guide**.
 * Auto switches are shipped together, (but not assembled).



Symbol

Rubber bumper

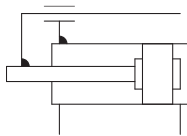

Refer to pages 10 and 11 for cylinders with auto switches.

- Auto switch proper mounting position (detection at stroke end) and mounting height
- Minimum stroke for auto switch mounting
- Operating range
- Auto switch mounting

Specifications

Bore size [mm]	Ø 12 (Ø 10 x 2)	Ø 16 (Ø 12 x 2)	Ø 20 (Ø 16 x 2)	Ø 25 (Ø 20 x 2)	Ø 32 (Ø 25 x 2)	Ø 40 (Ø 32 x 2)	Ø 50 (Ø 40 x 2)	Ø 63 (Ø 45 x 2)	Ø 80 (Ø 56 x 2)	Ø 100 (Ø 71 x 2)
Action	Double acting									
Fluid	Air									
Proof pressure	1.05 MPa									
Maximum operating pressure	0.7 MPa*1									
Minimum operating pressure	0.15 MPa									
Ambient and fluid temperature	5 to 60 °C									
Piston speed (Note)*	50 to 300 mm/s*1								50 to 250 mm/s*1	
Cushion	Rubber bumper on both ends									
Lubrication	Not required (Non-lube)									
Stroke length tolerance	$^{+1.5}_0$ mm									

Note) Maximum speed with no load

- * Depending on the system configuration selected, the specified speed may not be satisfied.
- *1 Maximum operating pressure and piston speed are different from the current product (MGP series).

Standard Strokes

Bore size [mm]	Standard stroke [mm]
Ø 12 (Ø 10 x 2) Ø 16 (Ø 12 x 2)	10, 20, 30, 50, 100
Ø 20 (Ø 16 x 2) Ø 25 (Ø 20 x 2)	20, 30, 50, 100, 150
Ø 32 (Ø 25 x 2) Ø 40 (Ø 32 x 2) Ø 50 (Ø 40 x 2) Ø 63 (Ø 45 x 2) Ø 80 (Ø 56 x 2) Ø 100 (Ø 71 x 2)	25, 50, 100, 150, 200

* Intermediate strokes are available as a special order.

Theoretical Output

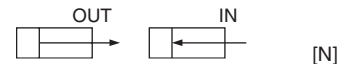

Bore size [mm]	Rod size [mm]	Operating direction	Piston area [mm ²]	Operating pressure [MPa]					
				0.2	0.3	0.4	0.5	0.6	0.7
Ø 12 (Ø 10 x 2)	6	OUT	157	31	47	63	79	94	110
		IN	101	20	30	40	50	60	70
Ø 16 (Ø 12 x 2)	6	OUT	226	45	68	90	113	136	158
		IN	170	34	51	68	85	102	119
Ø 20 (Ø 16 x 2)	8	OUT	402	80	121	161	201	241	281
		IN	302	60	90	121	151	181	211
Ø 25 (Ø 20 x 2)	10	OUT	628	126	188	251	314	377	440
		IN	471	94	141	188	236	283	330
Ø 32 (Ø 25 x 2)	12	OUT	982	196	295	393	491	589	687
		IN	756	151	227	302	378	453	529
Ø 40 (Ø 32 x 2)	16	OUT	1608	322	483	643	804	965	1126
		IN	1206	241	362	483	603	724	844
Ø 50 (Ø 40 x 2)	18	OUT	2513	503	754	1005	1257	1508	1759
		IN	2004	401	601	802	1002	1203	1403
Ø 63 (Ø 45 x 2)	20	OUT	3181	636	954	1272	1590	1909	2227
		IN	2553	511	766	1021	1276	1532	1787
Ø 80 (Ø 56 x 2)	25	OUT	4926	985	1478	1970	2463	2956	3448
		IN	3944	789	1183	1578	1972	2367	2761
Ø 100 (Ø 71 x 2)	30	OUT	7918	1584	2376	3167	3959	4751	5543
		IN	6505	1301	1951	2602	3252	3903	4553

Note) Theoretical output [N] = Pressure [MPa] x Piston area [mm²]

Weight

Bore size [mm]	Stroke [mm]							
	10	20	25	30	50	100	150	200
Ø 12 (Ø 10 x 2)	0.09	0.12	—	0.14	0.19	0.30	—	—
Ø 16 (Ø 12 x 2)	0.10	0.13	—	0.15	0.20	0.32	—	—
Ø 20 (Ø 16 x 2)	—	0.21	—	0.25	0.33	0.53	0.72	—
Ø 25 (Ø 20 x 2)	—	0.28	—	0.33	0.43	0.68	0.92	—
Ø 32 (Ø 25 x 2)	—	—	0.60	—	0.77	1.11	1.44	1.78
Ø 40 (Ø 32 x 2)	—	—	0.80	—	1.07	1.62	2.16	2.70
Ø 50 (Ø 40 x 2)	—	—	1.27	—	1.63	2.36	3.09	3.82
Ø 63 (Ø 45 x 2)	—	—	1.60	—	2.03	2.89	3.74	4.60
Ø 80 (Ø 56 x 2)	—	—	2.81	—	3.47	4.79	6.12	7.44
Ø 100 (Ø 71 x 2)	—	—	4.48	—	5.40	7.22	9.05	10.87

JMGP Series

Allowable Rotational Torque of Plate

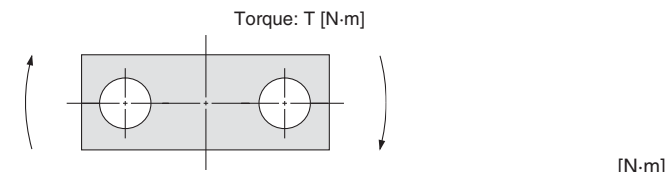

Bore size [mm]	Stroke [mm]							
	10	20	25	30	50	100	150	200
Ø 12 (Ø 10 x 2)	0.13	0.10	—	0.08	0.06	0.04	—	—
Ø 16 (Ø 12 x 2)	0.14	0.11	—	0.09	0.07	0.04	—	—
Ø 20 (Ø 16 x 2)	—	0.27	—	0.22	0.16	0.10	0.07	—
Ø 25 (Ø 20 x 2)	—	0.54	—	0.45	0.34	0.21	0.15	—
Ø 32 (Ø 25 x 2)	—	—	0.93	—	0.66	0.42	0.31	0.24
Ø 40 (Ø 32 x 2)	—	—	2.18	—	1.59	1.03	0.77	0.61
Ø 50 (Ø 40 x 2)	—	—	3.41	—	2.56	1.70	1.27	1.02
Ø 63 (Ø 45 x 2)	—	—	5.09	—	3.86	2.60	1.96	1.57
Ø 80 (Ø 56 x 2)	—	—	8.48	—	6.56	4.52	3.45	2.79
Ø 100 (Ø 71 x 2)	—	—	13.54	—	10.72	7.56	5.84	4.76

Non-rotating Accuracy of Plate

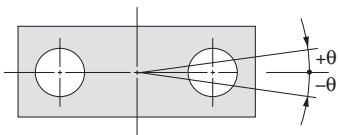

Non-rotating accuracy θ when retracted and when no load is applied should be not more than the values shown in the table.

Bore size [mm]	Non-rotating accuracy θ
Ø 12 (Ø 10 x 2)	±0.07°
Ø 16 (Ø 12 x 2)	
Ø 20 (Ø 16 x 2)	
Ø 25 (Ø 20 x 2)	±0.06°
Ø 32 (Ø 25 x 2)	
Ø 40 (Ø 32 x 2)	±0.05°
Ø 50 (Ø 40 x 2)	
Ø 63 (Ø 45 x 2)	±0.04°
Ø 80 (Ø 56 x 2)	
Ø 100 (Ø 71 x 2)	

Allowable Lateral Load

Bore size [mm]	Stroke [mm]							
	10	20	25	30	50	100	150	200
Ø 12 (Ø 10 x 2)	0.9	0.7	—	0.5	0.4	0.2	—	—
Ø 16 (Ø 12 x 2)	0.9	0.7	—	0.6	0.4	0.2	—	—
Ø 20 (Ø 16 x 2)	—	1.3	—	1.0	0.8	0.5	0.3	—
Ø 25 (Ø 20 x 2)	—	2.3	—	1.9	1.4	0.9	0.6	—
Ø 32 (Ø 25 x 2)	—	—	3.4	—	2.4	1.5	1.1	0.9
Ø 40 (Ø 32 x 2)	—	—	7.8	—	5.7	3.7	2.7	2.2
Ø 50 (Ø 40 x 2)	—	—	9.6	—	7.2	4.8	3.6	2.9
Ø 63 (Ø 45 x 2)	—	—	13.0	—	9.8	6.6	5.0	4.0
Ø 80 (Ø 56 x 2)	—	—	18.3	—	14.2	9.8	7.5	6.0
Ø 100 (Ø 71 x 2)	—	—	24.5	—	19.4	13.7	10.6	8.6

* Lateral load above is the value when eccentric distance $L = 0$ mm.

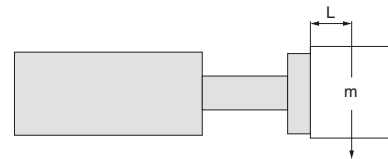

Allowable Kinetic Energy

With Rubber Bumper

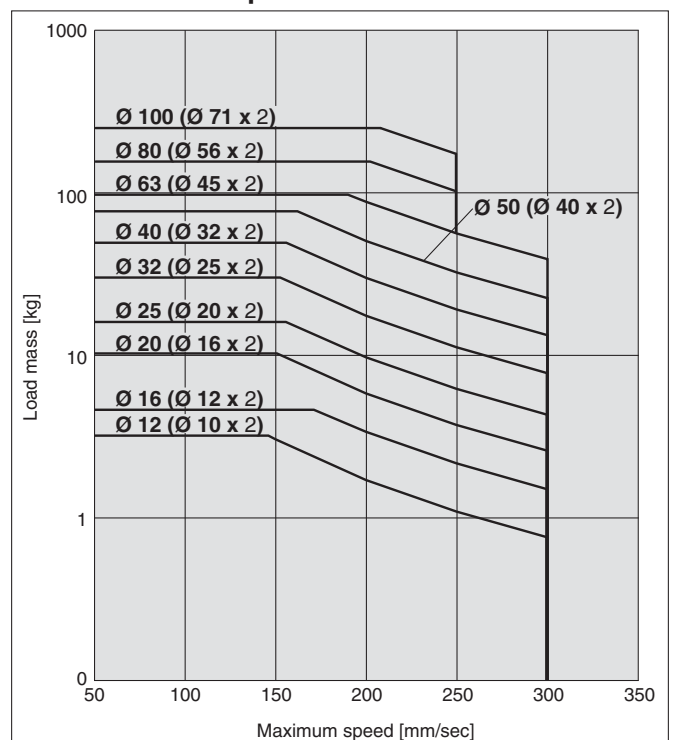

Bore Size **Ø 12 (Ø 10 x 2), Ø 16 (Ø 12 x 2)**

Standard: JMGP

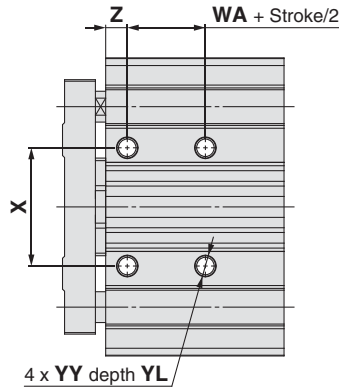

Bottom view

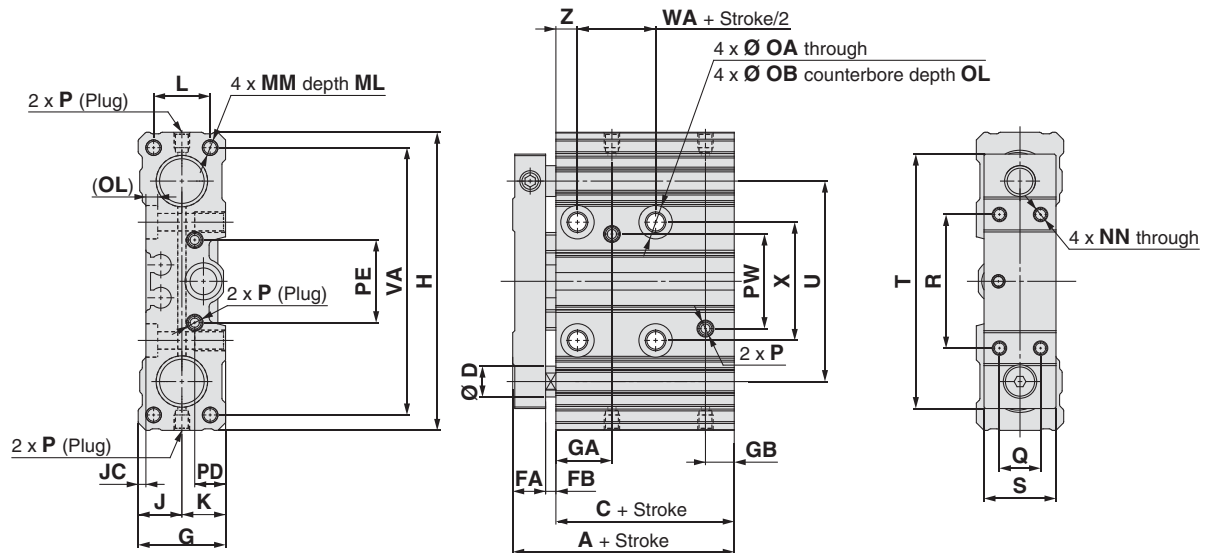

[mm]

Bore size	Standard stroke	A	C	D	FA	FB	G	GA	GB	H	J	JC	K	L	MM	ML	NN
Ø 12 (Ø 10 x 2)	10, 20, 30, 50, 100	33	24.5	6	6.5	2	17	11	5.5	58	8.5	1.5	8.5	11	M3 x 0.5	7.5	M2.5 x 0.45
Ø 16 (Ø 12 x 2)		33	24.5	6	6.5	2	18	11	5.5	64	9	3	9	11	M4 x 0.7	10	M3 x 0.5

Bore size	OA	OB	OL	P	PD	PE	PW	Q	R	S	T	U	VA	WA	X	YY	YL	Z
Ø 12 (Ø 10 x 2)	3.4	6.5	2.5	M3 x 0.5	6	16	18.5	8	26	14	49.5	39	52	10.2	23	M4 x 0.7	6	4.2
Ø 16 (Ø 12 x 2)	3.4	6.5	2	M3 x 0.5	6.5	16	18.5	8	28	14	53	42	57	10.2	24	M4 x 0.7	6	4.3

JMGP Series

Bore Size $\varnothing 20$ ($\varnothing 16 \times 2$) to $\varnothing 40$ ($\varnothing 32 \times 2$)

Standard: JMGP

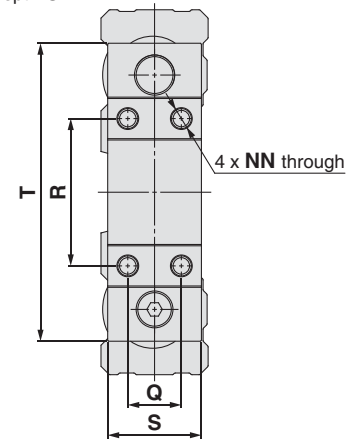
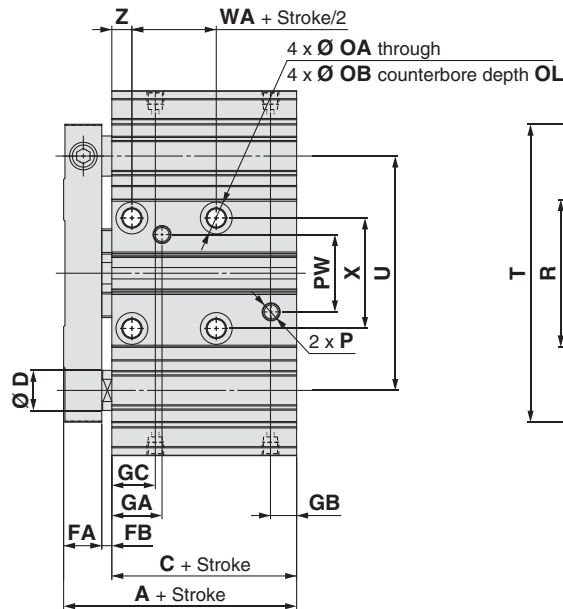
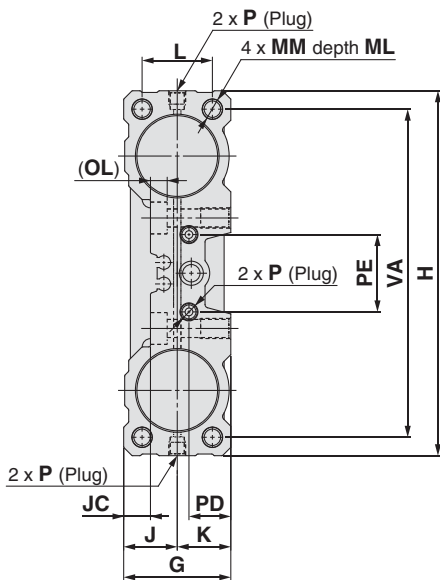
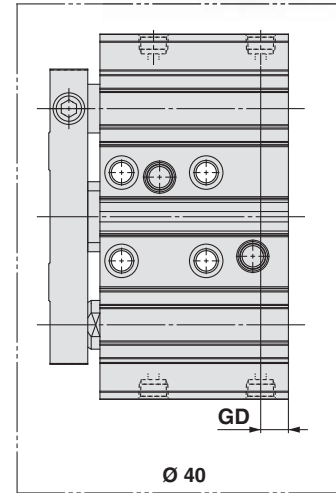
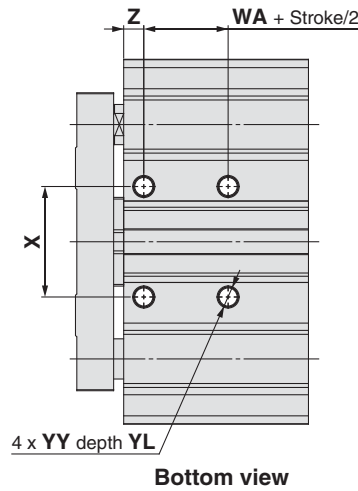

Bore size	Standard stroke	A	C	D	FA	FB	G	GA			GB	GC	GD	H	J	JC	K	L	MM	ML	NN
								—	TN	TF											
$\varnothing 20$ ($\varnothing 16 \times 2$)	20, 30, 50 100, 150	38	27.5	8	7.5	3	22	12.5	—	—	7.5	11	—	83	11	3	11	14	M4 x 0.7	10	M4 x 0.7
$\varnothing 25$ ($\varnothing 20 \times 2$)		39.5	28	10	8.5	3	26	12	—	—	7.5	11	—	93	13	4.5	13	17	M5 x 0.8	12.5	M5 x 0.8
$\varnothing 32$ ($\varnothing 25 \times 2$)	25, 50, 100 150, 200	44.5	30	12	11.5	3	32	15	—	—	7.5	13	—	109	16	8	16	21	M6 x 1	15	M6 x 1
$\varnothing 40$ ($\varnothing 32 \times 2$)		54	37	16	13	4	41	19.5	21	12	17.5	9	120	20.5	4	20.5	27	M8 x 1.25	20	M6 x 1	

Bore size	OA	OB	OL	P			PD	PE	PW			Q	R	S	T	U	VA	WA	X	YY	YL	Z
				—	TN	TF			—	TN	TF											
$\varnothing 20$ ($\varnothing 16 \times 2$)	4.3	8	3.5	M5 x 0.8	—	—	7.5	19	21	—	—	10	36	18	66	54	75	15.9	29	M5 x 0.8	7.5	4.5
$\varnothing 25$ ($\varnothing 20 \times 2$)	4.3	8	4	M5 x 0.8	—	—	9.5	22	22	—	—	12	38	22	75	60	84	12.7	31	M5 x 0.8	7.5	4.5
$\varnothing 32$ ($\varnothing 25 \times 2$)	5.4	9.5	5	M5 x 0.8	—	—	12.5	23	23	—	—	16	44	28	89	70	98	12.7	33	M6 x 1	9	6
$\varnothing 40$ ($\varnothing 32 \times 2$)	6.7	11	6	Rc 1/8	NPT 1/8	G 1/8	13	16.5	26	27.5	20	43	33	97	71	107	15.3	29	M8 x 1.25	10	7.1	

Bore Size **Ø 50 (Ø 40 x 2), Ø 63 (Ø 45 x 2)**

Standard: JMGP

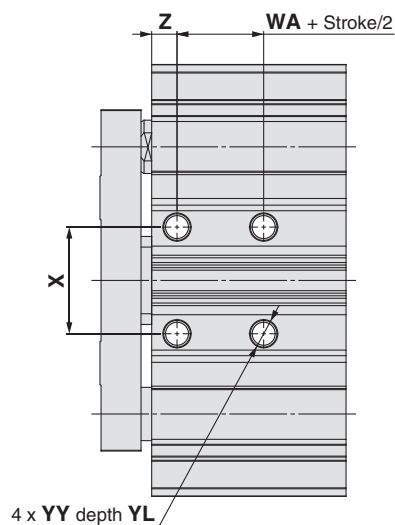

Bottom view

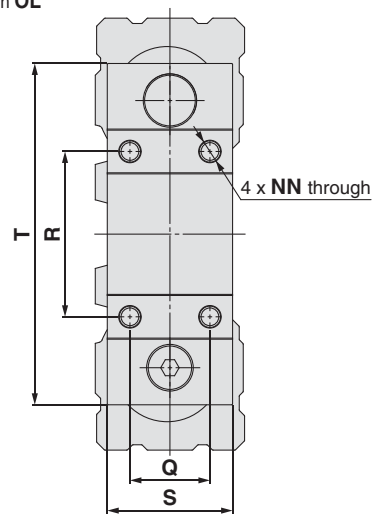
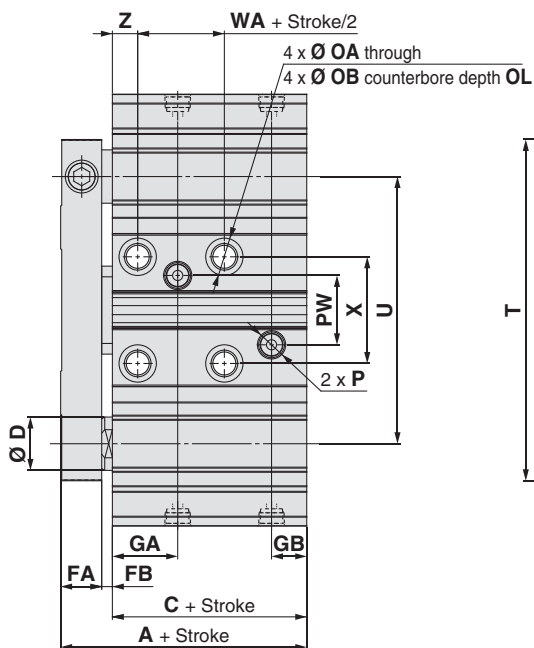
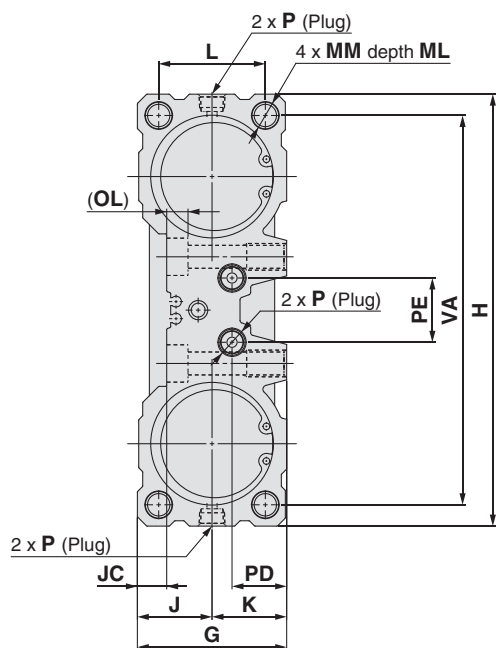

[mm]

Bore size	Standard stroke	A	C	D	FA	FB	G	GA	GB	H	J	JC	K	L	MM	ML	NN
Ø 50 (Ø 40 x 2)	25, 50, 100, 150, 200	63	43.5	18	15.5	4	51	20.5	12.5	148	25.5	9	25.5	37	M8 x 1.25	20	M8 x 1.25
Ø 63 (Ø 45 x 2)		67.5	48	20	15.5	4	56	24.5	13.5	162	28	11	28	40	M10 x 1.5	25	M8 x 1.25

Bore size	OA	OB	OL	P			PD	PE	PW			Q	R	S	T	U	VA	WA	X	YY	YL	Z
				—	TN	TF			—	TF	TN											
Ø 50 (Ø 40 x 2)	6.7	11	6	Rc 1/8	NPT 1/8	G 1/8	18	27	—	27	30	24	54	39	119	91	135	18.1	40	M8 x 1.25	12	7.6
Ø 63 (Ø 45 x 2)	8.6	14	8	Rc 1/8	NPT 1/8	G 1/8	20.5	24	—	26	30	30	62	47	128	100	146	20	40	M10 x 1.5	15	9.5

JMGP Series

Bore Size $\varnothing 80$ ($\varnothing 56 \times 2$), $\varnothing 100$ ($\varnothing 71 \times 2$)

Standard: JMGP

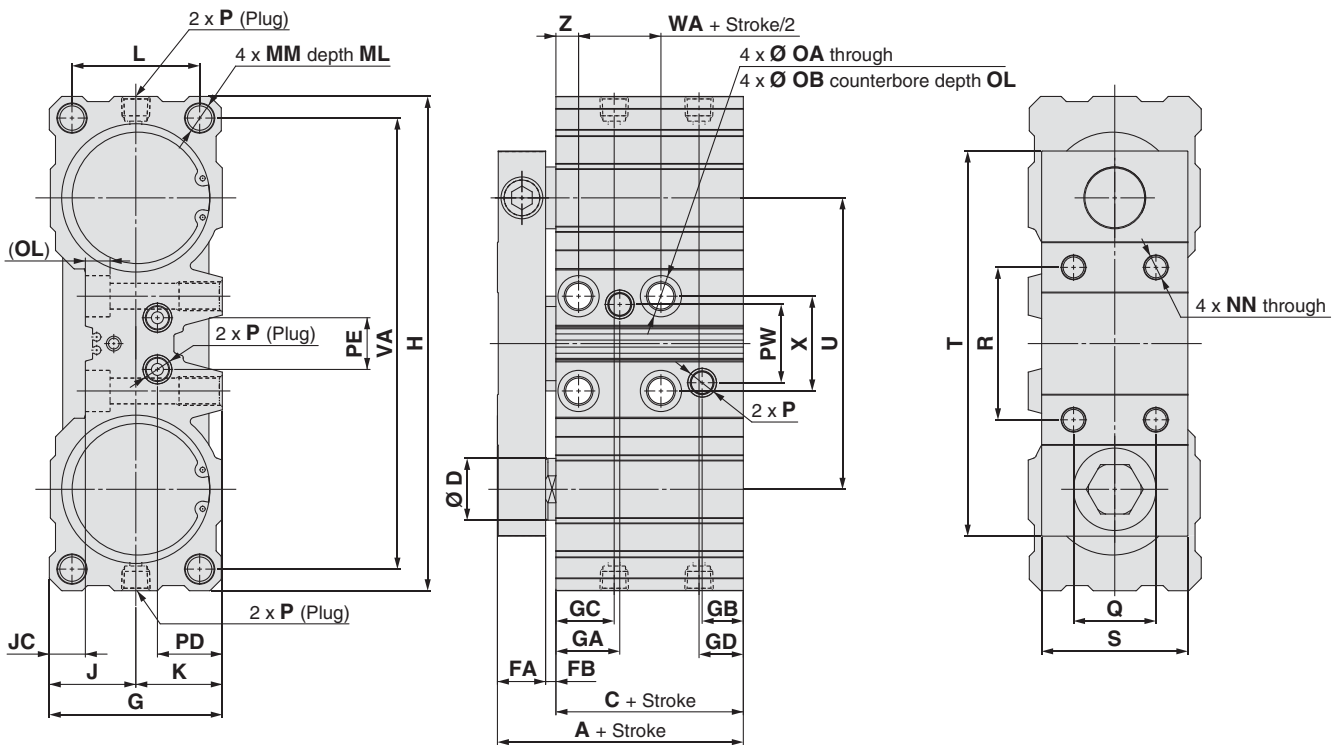
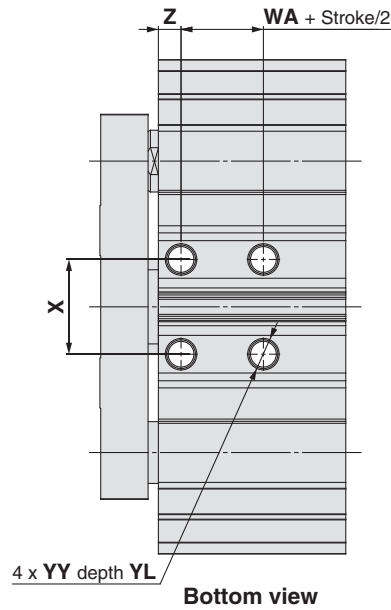

[mm]

Bore size	Standard stroke	A	C	D	FA	FB	G	GA	GB	GC	GD	H	J	JC	K	L	MM	ML	NN
$\varnothing 80$ ($\varnothing 56 \times 2$)	25, 50, 100 150, 200	85.5	62	25	19.5	4	69	28.5	20.5	25	22	202	34.5	15.5	34.5	50	M12 x 1.75	30	M10 x 1.5
$\varnothing 100$ ($\varnothing 71 \times 2$)		94.5	66	30	23.5	5	84	31	20	28.5	21.5	240	42	17.5	42	62	M14 x 2	35	M12 x 1.75

Bore size	OA	OB	OL	P			PD	PE	PW	Q	R	S	T	U	VA	WA	X	YY	YL	Z
				—	TN	TF														
$\varnothing 80$ ($\varnothing 56 \times 2$)	10.6	17.5	10	Rc 1/4	NPT 1/4	G 1/4	24.5	23	37	38	64	55	155	118	184	25.5	42	M12 x 1.75	18	9.5
$\varnothing 100$ ($\varnothing 71 \times 2$)	12.5	20	12	Rc 1/4	NPT 1/4	G 1/4	31.5	25	38	40	74	71	187	141.5	219	27.5	46	M14 x 2	21	11

JMGP Series Auto Switch Mounting

Auto Switch Proper Mounting Position (Detection at stroke end) and Mounting Height

D-M9□/M9□V
D-M9□W/M9□WV
D-M9□A/M9□AV

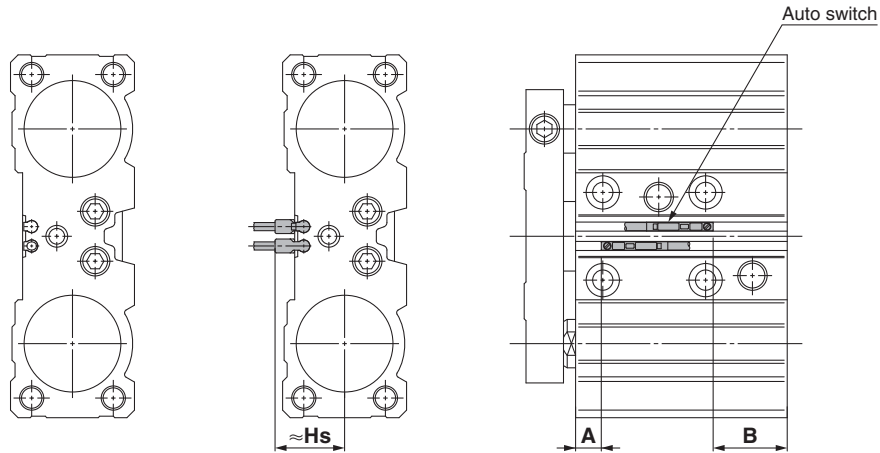

Auto Switch Proper Mounting Position [mm]

Auto switch model	D-M9□ D-M9□V D-M9□W D-M9□WV D-M9□A D-M9□AV	
	A	B
Ø 12 (Ø 10 x 2)	10.0	2.5
Ø 16 (Ø 12 x 2)	10.0	2.5
Ø 20 (Ø 16 x 2)	9.5	6.0
Ø 25 (Ø 20 x 2)	9.5	6.5
Ø 32 (Ø 25 x 2)	9.5	8.5
Ø 40 (Ø 32 x 2)	8.5	16.5
Ø 50 (Ø 40 x 2)	8.5	23.0
Ø 63 (Ø 45 x 2)	8.5	27.5
Ø 80 (Ø 56 x 2)	8.5	41.5
Ø 100 (Ø 71 x 2)	7.5	46.5

Note) Adjust the auto switch after confirming the operating condition in the actual setting.

Auto Switch Mounting Height [mm]

Auto switch model	D-M9□V D-M9□WV D-M9□AV	
	Bore size	Hs
Ø 12 (Ø 10 x 2)		14.0
Ø 16 (Ø 12 x 2)		14.0
Ø 20 (Ø 16 x 2)		14.0
Ø 25 (Ø 20 x 2)		14.0
Ø 32 (Ø 25 x 2)		—
Ø 40 (Ø 32 x 2)		23.5
Ø 50 (Ø 40 x 2)		—
Ø 63 (Ø 45 x 2)		—
Ø 80 (Ø 56 x 2)		—
Ø 100 (Ø 71 x 2)		—

Minimum Stroke for Auto Switch Mounting

Auto switch model	Number of auto switches	Bore size [mm]									
		Ø 12 (Ø 10 x 2)	Ø 16 (Ø 12 x 2)	Ø 20 (Ø 16 x 2)	Ø 25 (Ø 20 x 2)	Ø 32 (Ø 25 x 2)	Ø 40 (Ø 32 x 2)	Ø 50 (Ø 40 x 2)	Ø 63 (Ø 45 x 2)	Ø 80 (Ø 56 x 2)	Ø 100 (Ø 71 x 2)
D-M9□V	1	5									
	2	5									
D-M9□	1	5 Note 1)					5				
	2	10 Note 1)	10								
D-M9□W	1	5 Note 2)									
	2	10 Note 2)	10								
D-M9□WV D-M9□AV	1	5 Note 2)									
	2	10									
D-M9□A	1	5 Note 2)									
	2	10 Note 2)									

Note 1) Confirm that it is possible to secure the minimum bending radius of 10 mm of the auto switch lead wire before use.

Note 2) Confirm that it is possible to securely set the auto switch(es) within the range of indicator green light ON range before use.

For in-line entry type, also consider Note 1) shown above.

Operating Range

Auto switch model	Bore size [mm]									
	Ø 12 (Ø 10 x 2)	Ø 16 (Ø 12 x 2)	Ø 20 (Ø 16 x 2)	Ø 25 (Ø 20 x 2)	Ø 32 (Ø 25 x 2)	Ø 40 (Ø 32 x 2)	Ø 50 (Ø 40 x 2)	Ø 63 (Ø 45 x 2)	Ø 80 (Ø 56 x 2)	Ø 100 (Ø 71 x 2)
D-M9□/M9□V D-M9□W/M9□WV D-M9□A/M9□AV	3.5	3	4	4	4	4	4	4	4	4

* Values which include hysteresis are for guideline purposes only, they are not a guarantee (assuming approximately ±30 % dispersion) and may change substantially depending on the ambient environment.

Auto Switch Mounting

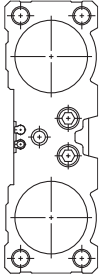
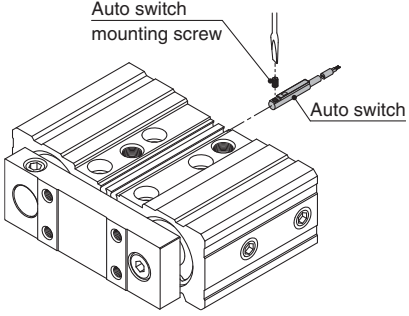
Applicable auto switches	D-M9□/M9□V D-M9□W/M9□WV D-M9□A/M9□AV				
Bore size	Ø 12 (Ø 10 x 2) to Ø 100 (Ø 71 x 2)				
Auto switch mounting surfaces	Surfaces with auto switch mounting slot 				
Mounting of auto switch	 <ul style="list-style-type: none"> When tightening the auto switch mounting screw, use a watchmakers' screwdriver with a handle 5 to 6 mm in diameter. <p>Tightening Torque for Auto Switch Mounting Screw [N·m]</p> <table border="1"> <thead> <tr> <th>Auto switch model</th> <th>Tightening torque</th> </tr> </thead> <tbody> <tr> <td>D-M9□(V) D-M9□W(V) D-M9□A(V)</td> <td>0.05 to 0.15</td> </tr> </tbody> </table>	Auto switch model	Tightening torque	D-M9□(V) D-M9□W(V) D-M9□A(V)	0.05 to 0.15
Auto switch model	Tightening torque				
D-M9□(V) D-M9□W(V) D-M9□A(V)	0.05 to 0.15				

Caution on Proximity Installation

When cylinders are adjacent to one another as shown in the figure below, provide a space between them of at least, the amount shown in the tables below.

If the space is not sufficient, the magnets in adjacent cylinders may cause the auto switches to malfunction.

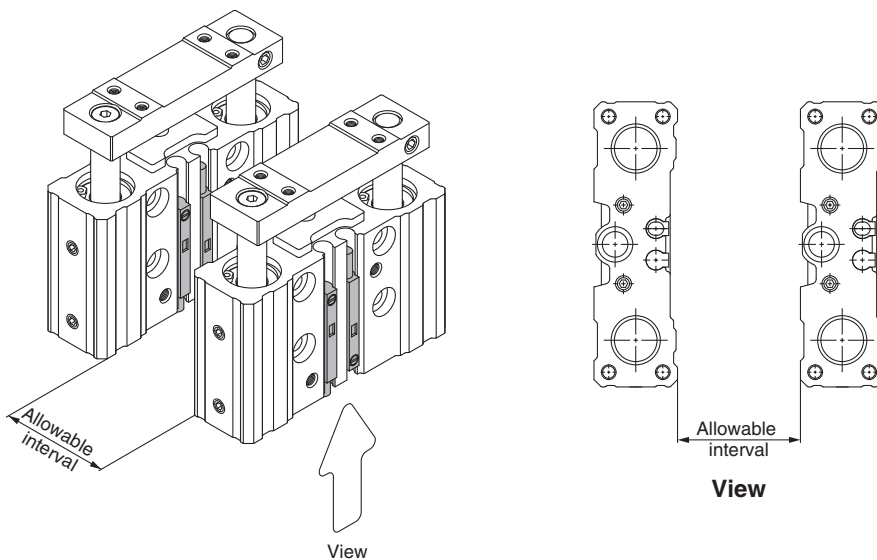

Bore size	Allowable interval [mm]
Ø 12 (Ø 10 x 2)	15
Ø 16 (Ø 12 x 2)	15
Ø 20 (Ø 16 x 2)	15
Ø 25 (Ø 20 x 2)	10
Ø 32 (Ø 25 x 2)	5
Ø 40 (Ø 32 x 2)	0
Ø 50 (Ø 40 x 2)	0
Ø 63 (Ø 45 x 2)	0
Ø 80 (Ø 56 x 2)	0
Ø 100 (Ø 71 x 2)	0

Prior to Use

Auto Switch Connection and Example

Sink Input Specifications

3-wire, NPN

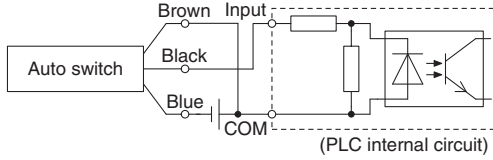

2-wire

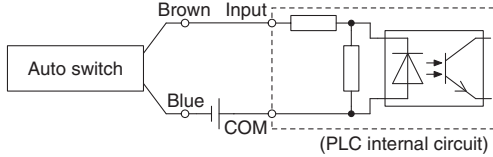

Source Input Specifications

3-wire, PNP

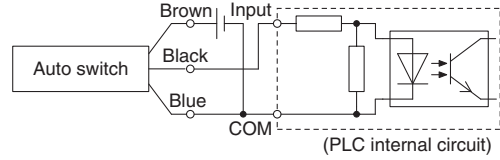

2-wire

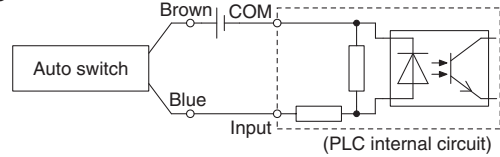

Connect according to the applicable PLC input specifications, as the connection method will vary depending on the PLC input specifications.

Example of AND (Series) and OR (Parallel) Connection

* When using solid state auto switches, ensure the application is set up so the signals for the first 50 ms are invalid.

3-wire AND connection for NPN output (Using relays)

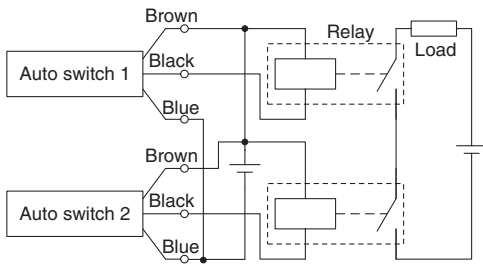

(Performed with auto switches only)

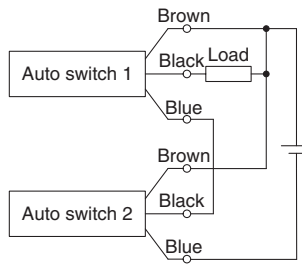

3-wire OR connection for NPN output

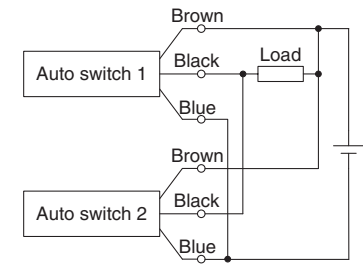

3-wire AND connection for PNP output (Using relays)

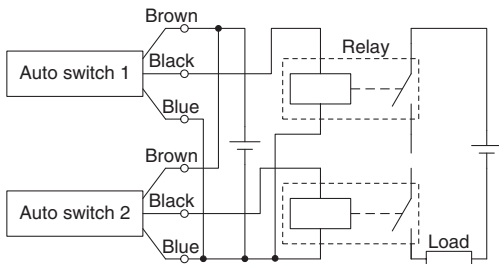

(Performed with auto switches only)

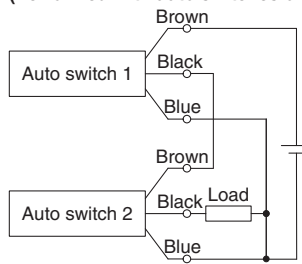

3-wire OR connection for PNP output

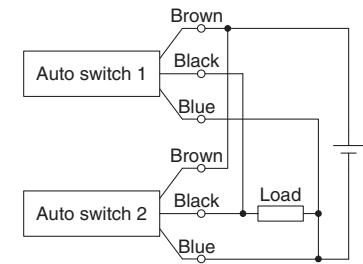

2-wire AND connection

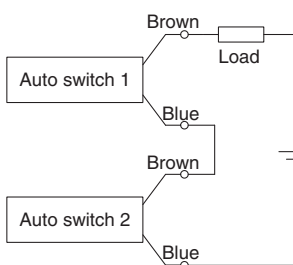

When two auto switches are connected in series, a load may malfunction because the load voltage will decline when in the ON state. The indicator lights will light up when both of the auto switches are in the ON state. Auto switches with load voltage less than 20 V cannot be used.

$$\begin{aligned} \text{Load voltage at ON} &= \text{Power supply voltage} - \text{Residual voltage} \times 2 \text{ pcs.} \\ &= 24 \text{ V} - 4 \text{ V} \times 2 \text{ pcs.} \\ &= 16 \text{ V} \end{aligned}$$

Example: Power supply is 24 V DC
Internal voltage drop in auto switch is 4 V.

2-wire OR connection

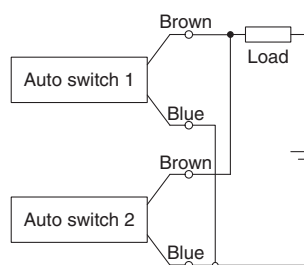

(Solid state)
When two auto switches are connected in parallel, malfunction may occur because the load voltage will increase when in the OFF state.

(Reed)
Because there is no current leakage, the load voltage will not increase when turned OFF. However, depending on the number of auto switches in the ON state, the indicator lights may sometimes grow dim or not light up, due to the dispersion and reduction of the current flowing to the auto switches.

$$\begin{aligned} \text{Load voltage at OFF} &= \text{Leakage current} \times 2 \text{ pcs.} \times \text{Load impedance} \\ &= 1 \text{ mA} \times 2 \text{ pcs.} \times 3 \text{ k}\Omega \\ &= 6 \text{ V} \end{aligned}$$

Example: Load impedance is 3 k Ω .
Leakage current from auto switch is 1 mA.



JMGP Series

Specific Product Precautions 1

Be sure to read this before handling the products. Refer to the back cover for Safety Instructions. For Actuator and Auto Switch Precautions, refer to “Handling Precautions for SMC Products” and the Operation Manual on SMC website, <http://www.smc.eu>

Mounting

⚠ Warning

1. Never place your hands or fingers between the plate and the body.

Be very careful to prevent your hands or fingers from getting caught in the gap between the cylinder body and the plate when air is applied.

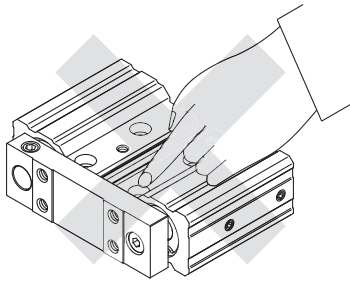

⚠ Caution

1. Use cylinders within the piston speed range.

An orifice is set for this cylinder, but the piston speed may exceed the operating range if the speed controller is not used. If the cylinder is used outside the operating speed range, it may cause damage to the cylinder and shorten the service life. Adjust the speed by installing the speed controller and use the cylinder within the limited range.

2. Pay attention to the operating speed when the product is mounted vertically.

When using the product in the vertical direction, if the load factor is large, the operating speed can be faster than the control speed of the speed controller (i.e. quick extension). In such cases, it is recommended to use a dual speed controller.

3. Do not scratch or gouge the sliding portion of the piston rod.

Damaged seals etc. will result in leakage or malfunction.

4. Do not dent or scratch the mounting surface of the body and the plate.

The flatness of the mounting surface may not be maintained, which would cause an increase in sliding resistance.

5. Make sure that the cylinder mounting surface has a flatness of 0.05 mm or less.

If the flatness of the workpieces and brackets mounted on the plate is not appropriate, sliding resistance may increase. If it is difficult to maintain a flatness of 0.05 or less, put a thin shim ring (prepared by user) between the plate and workpiece mounting surface to prevent the sliding resistance from increasing.

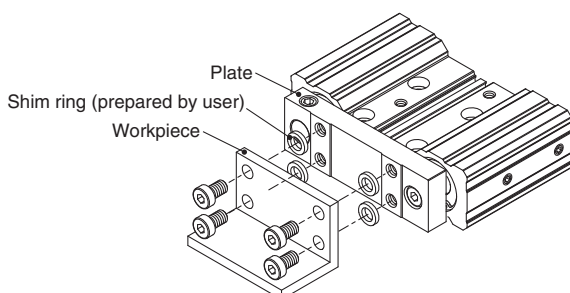

Mounting

⚠ Caution

6. Bottom of cylinder

For bottom mounting, make a hole to the mounting base of the customer for hexagon socket head cap screws.

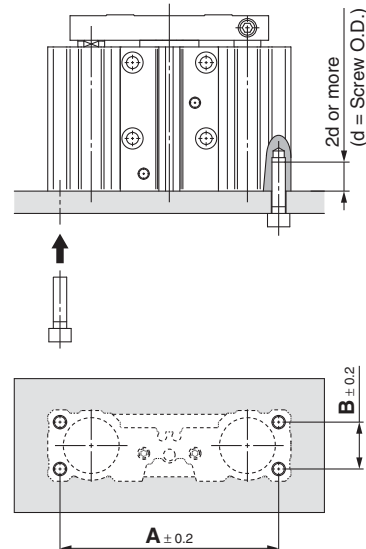

Bore size [mm]	A [mm]	B [mm]	Hexagon socket head cap screw
Ø 12 (Ø 10 x 2)	52	11	M3 x 0.5
Ø 16 (Ø 12 x 2)	57	11	M4 x 0.7
Ø 20 (Ø 16 x 2)	75	14	M4 x 0.7
Ø 25 (Ø 20 x 2)	84	17	M5 x 0.8
Ø 32 (Ø 25 x 2)	98	21	M6 x 1.0
Ø 40 (Ø 32 x 2)	107	27	M8 x 1.25
Ø 50 (Ø 40 x 2)	135	37	M8 x 1.25
Ø 63 (Ø 45 x 2)	146	40	M10 x 1.5
Ø 80 (Ø 56 x 2)	184	50	M12 x 1.75
Ø 100 (Ø 71 x 2)	219	62	M14 x 2

7. Depending on the system configuration selected, the specified speed may not be satisfied.

Other

⚠ Caution

This product should not be used as a stopper.



JMGP Series

Specific Product Precautions 2

Be sure to read this before handling the products. Refer to the back cover for Safety Instructions. For Actuator and Auto Switch Precautions, refer to “Handling Precautions for SMC Products” and the Operation Manual on SMC website, <http://www.smc.eu>

Piping

⚠ Caution

Depending on the operating conditions, piping port positions can be changed by using a plug. When switching the plugged port, check for the air leakage. If small air leakage is detected, order the below plugs, and reassemble it.

Plug Part Number

Bore size [mm]	Part number	Port thread type	Quantity*
Ø 12 (Ø 10 x 2) Ø 16 (Ø 12 x 2)	P-M3	M3	8
Ø 20 (Ø 16 x 2) Ø 25 (Ø 20 x 2) Ø 32 (Ø 25 x 2)	P-M5	M5	8
Ø 40 (Ø 32 x 2) Ø 50 (Ø 40 x 2) Ø 63 (Ø 45 x 2)	P-R1	Rc 1/8	8
	P-N1	NPT 1/8	8
	P-G1	G 1/8	8
Ø 80 (Ø 56 x 2) Ø 100 (Ø 71 x 2)	P-R2	Rc 1/4	8
	P-N2	NPT 1/4	8
	P-G2	G 1/4	8

* 1 set includes 8 pieces.

In addition, when reassembling the replacement plug, apply grease slightly to the whole circumference of the female thread of the port. (M3, M5 type only)

Use SMC's recommended grease.

Grease pack part number: GR-S-010 (10 g)

M3, M5, Rc port, NPT port

Use the correct tightening torques listed below.

Connection thread (plug) size	Proper tightening torque [N·m]	Dimension "a"
M3	0.65 to 0.75	—
M5	3.2 to 3.8	—
1/8	3.5 to 5.5	1 mm or less
1/4	6.5 to 12	1 mm or less

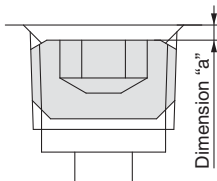

G port

Screw in the plug to the surface of the body (dimension "a" in the drawing) by checking visually instead of using the tightening torque shown above.



Safety Instructions

These safety instructions are intended to prevent hazardous situations and/or equipment damage. These instructions indicate the level of potential hazard with the labels of “Caution,” “Warning” or “Danger.” They are all important notes for safety and must be followed in addition to International Standards (ISO/IEC)*1), and other safety regulations.

-  **Caution:** Caution indicates a hazard with a low level of risk which, if not avoided, could result in minor or moderate injury.
-  **Warning:** Warning indicates a hazard with a medium level of risk which, if not avoided, could result in death or serious injury.
-  **Danger:** Danger indicates a hazard with a high level of risk which, if not avoided, will result in death or serious injury.

- *1) ISO 4414: Pneumatic fluid power – General rules relating to systems.
- ISO 4413: Hydraulic fluid power – General rules relating to systems.
- IEC 60204-1: Safety of machinery – Electrical equipment of machines. (Part 1: General requirements)
- ISO 10218-1: Manipulating industrial robots - Safety. etc.

Warning

- The compatibility of the product is the responsibility of the person who designs the equipment or decides its specifications.**
Since the product specified here is used under various operating conditions, its compatibility with specific equipment must be decided by the person who designs the equipment or decides its specifications based on necessary analysis and test results. The expected performance and safety assurance of the equipment will be the responsibility of the person who has determined its compatibility with the product. This person should also continuously review all specifications of the product referring to its latest catalogue information, with a view to giving due consideration to any possibility of equipment failure when configuring the equipment.
- Only personnel with appropriate training should operate machinery and equipment.**
The product specified here may become unsafe if handled incorrectly. The assembly, operation and maintenance of machines or equipment including our products must be performed by an operator who is appropriately trained and experienced.
- Do not service or attempt to remove product and machinery/equipment until safety is confirmed.**
 - The inspection and maintenance of machinery/equipment should only be performed after measures to prevent falling or runaway of the driven objects have been confirmed.
 - When the product is to be removed, confirm that the safety measures as mentioned above are implemented and the power from any appropriate source is cut, and read and understand the specific product precautions of all relevant products carefully.
 - Before machinery/equipment is restarted, take measures to prevent unexpected operation and malfunction.
- Contact SMC beforehand and take special consideration of safety measures if the product is to be used in any of the following conditions.**
 - Conditions and environments outside of the given specifications, or use outdoors or in a place exposed to direct sunlight.
 - Installation on equipment in conjunction with atomic energy, railways, air navigation, space, shipping, vehicles, military, medical treatment, combustion and recreation, or equipment in contact with food and beverages, emergency stop circuits, clutch and brake circuits in press applications, safety equipment or other applications unsuitable for the standard specifications described in the product catalogue.
 - An application which could have negative effects on people, property, or animals requiring special safety analysis.
 - Use in an interlock circuit, which requires the provision of double interlock for possible failure by using a mechanical protective function, and periodical checks to confirm proper operation.

Limited warranty and Disclaimer/ Compliance Requirements

The product used is subject to the following “Limited warranty and Disclaimer” and “Compliance Requirements”.
Read and accept them before using the product.

Limited warranty and Disclaimer

- The warranty period of the product is 1 year in service or 1.5 years after the product is delivered, whichever is first.*2)
Also, the product may have specified durability, running distance or replacement parts. Please consult your nearest sales branch.
- For any failure or damage reported within the warranty period which is clearly our responsibility, a replacement product or necessary parts will be provided. This limited warranty applies only to our product independently, and not to any other damage incurred due to the failure of the product.
- Prior to using SMC products, please read and understand the warranty terms and disclaimers noted in the specified catalogue for the particular products.

*2) Vacuum pads are excluded from this 1 year warranty.

A vacuum pad is a consumable part, so it is warranted for a year after it is delivered. Also, even within the warranty period, the wear of a product due to the use of the vacuum pad or failure due to the deterioration of rubber material are not covered by the limited warranty.

Caution

- The product is provided for use in manufacturing industries.**
The product herein described is basically provided for peaceful use in manufacturing industries.
If considering using the product in other industries, consult SMC beforehand and exchange specifications or a contract if necessary.
If anything is unclear, contact your nearest sales branch.

Caution

- SMC products are not intended for use as instruments for legal metrology.**
Measurement instruments that SMC manufactures or sells have not been qualified by type approval tests relevant to the metrology (measurement) laws of each country. Therefore, SMC products cannot be used for business or certification ordained by the metrology (measurement) laws of each country.

Safety Instructions

Be sure to read “Handling Precautions for SMC Products” (M-E03-3) before using.

SMC Corporation (Europe)

Austria	☎ +43 (0)2262622800	www.smc.at	office@smc.at	Lithuania	☎ +370 5 2308118	www.smclt.lt	info@smclt.lt
Belgium	☎ +32 (0)33551464	www.smcpnematics.be	info@smcpnematics.be	Netherlands	☎ +31 (0)205318888	www.smcpnematics.nl	info@smcpnematics.nl
Bulgaria	☎ +359 (0)2807670	www.smc.bg	office@smc.bg	Norway	☎ +47 67129020	www.smc-norge.no	post@smc-norge.no
Croatia	☎ +385 (0)13707288	www.smc.hr	office@smc.hr	Poland	☎ +48 222119600	www.smc.pl	office@smc.pl
Czech Republic	☎ +420 541424611	www.smc.cz	office@smc.cz	Portugal	☎ +351 226166570	www.smc.eu	postpt@smc.smces.es
Denmark	☎ +45 70252900	www.smcdk.com	smc@smcdk.com	Romania	☎ +40 213205111	www.smcromania.ro	smcromania@smcromania.ro
Estonia	☎ +372 6510370	www.smcpnematics.ee	smc@smcpnematics.ee	Russia	☎ +7 8127185445	www.smc-pneumatik.ru	info@smc-pneumatik.ru
Finland	☎ +358 207513513	www.smc.fi	smc@smc.fi	Slovakia	☎ +421 (0)413213212	www.smc.sk	office@smc.sk
France	☎ +33 (0)164761000	www.smc-france.fr	info@smc-france.fr	Slovenia	☎ +386 (0)73885412	www.smc.si	office@smc.si
Germany	☎ +49 (0)61034020	www.smc.de	info@smc.de	Spain	☎ +34 902184100	www.smc.eu	post@smc.smces.es
Greece	☎ +30 210 2717265	www.smchellas.gr	sales@smchellas.gr	Sweden	☎ +46 (0)86031200	www.smc.nu	post@smc.nu
Hungary	☎ +36 23511390	www.smc.hu	office@smc.hu	Switzerland	☎ +41 (0)523963131	www.smc.ch	info@smc.ch
Ireland	☎ +353 (0)14039000	www.smcpnematics.ie	sales@smcpnematics.ie	Turkey	☎ +90 212 489 0 440	www.smcpnomatik.com.tr	info@smcpnomatik.com.tr
Italy	☎ +39 0292711	www.smcitalia.it	mailbox@smcitalia.it	UK	☎ +44 (0)845 121 5122	www.smcpnematics.co.uk	sales@smcpnematics.co.uk
Latvia	☎ +371 67817700	www.smc.lv	info@smclv.lv				

SMC CORPORATION Akihbara UDX 15F, 4-14-1, Sotokanda, Chiyoda-ku, Tokyo 101-0021, JAPAN Phone: 03-5207-8249 FAX: 03-5298-5362