

Clean One-touch Fittings For Blowing Series *KP*



⚠ Caution

Series KP is a line of special One-touch fittings for use in clean room blowing and washing lines. Please consult with SMC regarding other types of applications.

Seal material: The durability of EPDM with respect to mineral oils is inferior, which makes it unsuitable for piping in general pneumatic equipment.

Recommended Applicable Tubing

Tubing material	Polyolefin: Series TPH Soft polyolefin: Series TPS
Tubing O.D.	ø4, ø6, ø8, ø10, ø12

Note 1) Polyurethane tubing: Series TU, Nylon tubing: Series T, and Soft nylon tubing: Series TS can also be used. However, the degree of clean performance will be reduced.

Note 2) Due to the softness of polyurethane tubing, it may fold when being inserted. Hold the end of the tubing and insert it all the way in. Refer to "Installation and Removal of Tubing" on page 15.)

Specifications

Particulate generation grade	Grade 1 Note 1)
Fluid	Air/Nitrogen gas/Water (pure water) Note 2)
Maximum operating pressure (20°C)	1MPa Note 3)
Operating vacuum pressure	-100kPa
Proof pressure (20°C)	3MPa
Ambient and fluid temperature	-20°C to 80°C
Threads	JIS B0203 (Taper thread for piping)

Note 1) Refer to particulate generation grade classifications.

Note 2) Consult SMC regarding other fluids.

Note 3) The maximum operating pressure is the value at 20°C. Refer to the operating pressure curve for other temperatures.

Principal Parts Material

Body	Polypropylene resin
Stud	Polypropylene resin
Chuck	Stainless steel 304
Guide, Stopper, Drive bushing	Stainless steel 304
Collet, Release button	Polypropylene resin
Seal, O-ring, Bumper	EPDM

Particulate Generation Grade Classifications

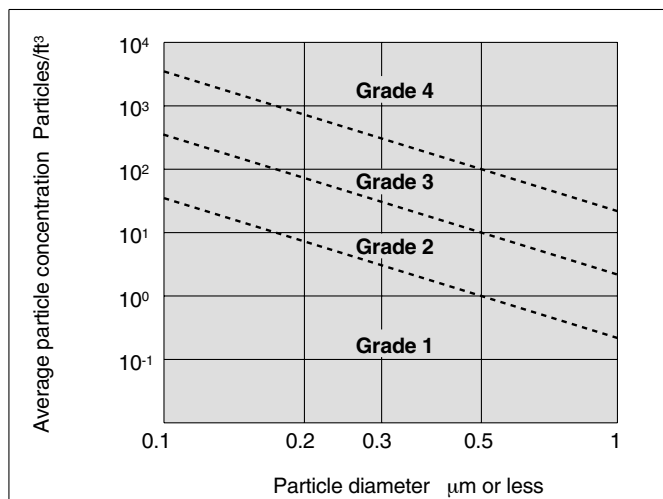

Relation between Operating Temperature and Maximum Operating Pressure

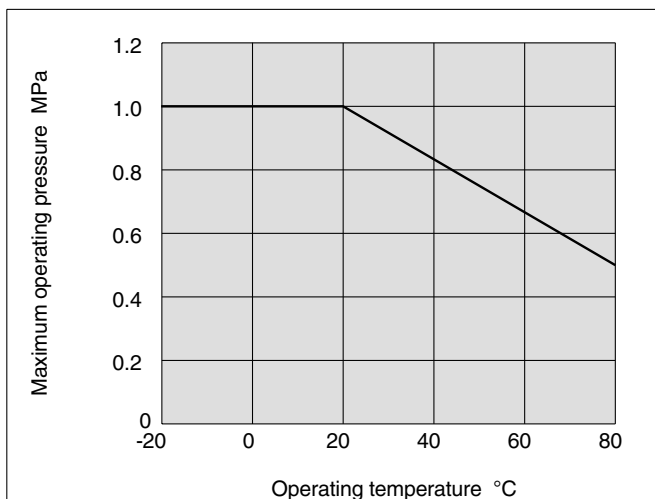

How to Order

Clean One-touch fittings (for blowing)

Model

H	Male connector, Straight union
L	Union elbow, Male elbow
T	Male branch tee, Union tee
Y	Male run tee
U	Male branch, Union "Y"
R	Plug-in reducer

Port size/Applicable tubing O.D.

Thread connection	01	R 1/8
	02	R 1/4
	03	R 3/8
	04	R 1/2
Tubing (rod) connection	00	Same dia. tubing
	04	ø4
	06	ø6
	08	ø8
	10	ø10
	12	ø12

Applicable tubing O.D.

04	ø4
06	ø6
08	ø8
10	ø10
12	ø12

Applicable fitting size

04	ø4
06	ø6
08	ø8
10	ø10
12	ø12

Plug

Clean One-touch fittings

Example Order Codes: KP H 06 01 and KP P 08

- K
- M
- H
- D
- MS
- T
- VMG

Construction

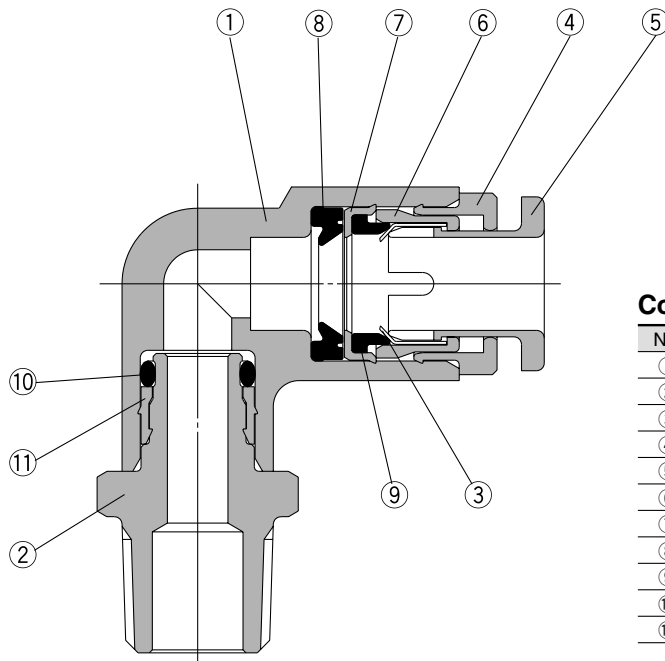

Component Parts

No.	Description	Material
①	Body	Polypropylene resin
②	Stud	Polypropylene resin
③	Chuck	Stainless steel 304
④	Guide	Stainless steel 304
⑤	Release button	Polypropylene resin (color: light green)
⑥	Collet	Polypropylene resin
⑦	Stopper	Stainless steel 304
⑧	Seal	EPDM
⑨	Bumper	EPDM
⑩	O-ring	EPDM
⑪	Drive bushing	Stainless steel 304

Series KP

Dimensions

Male Connector: KPH



Applicable tubing O.D. mm	Connection thread R	Model	H (width across flats)	L	A*	M	Effective area mm ²		Weight g
							TPH	TPS	
4	1/8	KPH04-01	12	25.4	21.5	18	4	4	3
	1/4	KPH04-02	14	25.4	19.5				4
6	1/8	KPH06-01	14	25.9	22	19.5	10	10	4
	1/4	KPH06-02	14	26.4	20.5				5
8	1/8	KPH08-01	17	32.3	28.5	21.5	26	18	6
	1/4	KPH08-02	17	30.3	24.5				7
10	1/4	KPH10-02	19	37.5	32	24	41	29	10
	3/8	KPH10-03		33	27				11
12	3/8	KPH12-03	22	34	28	25	58	46	12
	1/2	KPH12-04		34.5	27				13

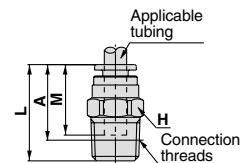

* Reference dimension for R threads after installation

Male Elbow: KPL



Applicable tubing O.D. mm	Connection thread R	Model	H (width across flats)	Note 1) ϕD_1	ϕD_2	L ₁	L ₂	A*	M	Effective area mm ²		Weight g
										TPH	TPS	
4	1/8	KPL04-01	12	10.4	10	20.7	23.2	24.5	18	3.5	3.5	4
	1/4	KPL04-02	14				27.2	26.5				5
6	1/8	KPL06-01	12	12.8	10	22.8	24.4	27	19.5	9	9	5
	1/4	KPL06-02	14				28.4	29				6
8	1/8	KPL08-01	14	15.2	12	26.3	26.6	30	21.5	22	15	8
	1/4	KPL08-02	14				29.4	31.5				9
10	1/4	KPL10-02	17	18.5	17	29.4	32.1	35.5	24	35	25	13
	3/8	KPL10-03					33.1	36.5				14
12	3/8	KPL12-03	20.9	22	31.4	22	34.3	38.5	25	50	40	15
	1/2	KPL12-04					38.3	41.5				18

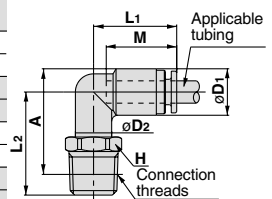

* Reference dimension for R threads after installation Note 1) ϕD_1 indicates the maximum diameter.

Male Branch Tee: KPT



Applicable tubing O.D. mm	Connection thread R	Model	H (width across flats)	Note 1) ϕD_1	ϕD_2	L ₁	L ₂	A*	M	Effective area mm ²		Weight g
										TPH	TPS	
4	1/8	KPT04-01	12	10.4	10	20.7	23.2	24.5	18	4.1	4.1	6
	1/4	KPT04-02	14				27.2	26.5				7
6	1/8	KPT06-01	12	12.8	10	22.8	24.4	27	19.5	11	11	8
	1/4	KPT06-02	14				28.4	29				9
8	1/8	KPT08-01	14	15.2	12	26.3	26.6	30	21.5	26.3	18.2	12
	1/4	KPT08-02	14				29.4	31.5				13
10	1/4	KPT10-02	17	18.5	17	29.4	32.1	35.5	24	40.8	29	20
	3/8	KPT10-03					33.1	36.5				21
12	3/8	KPT12-03	20.9	22	31.4	22	34.3	38.5	25	57.2	45.2	24
	1/2	KPT12-04					38.3	41.5				27

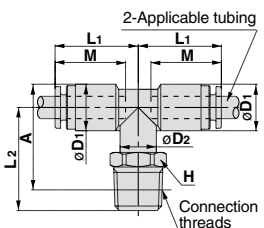

* Reference dimension for R threads after installation Note 1) ϕD_1 indicates the maximum diameter.

Male Run Tee: KPY



Applicable tubing O.D. mm	Connection thread R	Model	H (width across flats)	Note 1) ϕD_1	ϕD_2	L ₁	L ₂	A*	M	Effective area mm ²		Weight g
										TPH	TPS	
4	1/8	KPY04-01	12	10.4	10	20.7	23.2	40	18	7.5	7.5	6
	1/4	KPY04-02	14				27.2	42				7
6	1/8	KPY06-01	12	12.8	10	22.8	24.4	43	19.5	11	11	8
	1/4	KPY06-02	14				28.4	45.5				9
8	1/8	KPY08-01	14	15.2	12	26.3	26.6	49	21.5	21	21	12
	1/4	KPY08-02	14				29.4	50				13
10	1/4	KPY10-02	17	18.5	17	29.4	32.1	56	24	45	45	19
	3/8	KPY10-03					33.1	56.5				20
12	3/8	KPY12-03	20.9	22	31.4	22	34.3	59.5	25	57	57	21
	1/2	KPY12-04					38.3	62.5				24

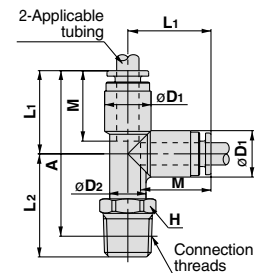

*Reference dimension for R threads after installation Note 1) ϕD_1 indicates the maximum diameter.

Male Branch "Y": KPU



Applicable tubing O.D. mm	Connection thread R	Model	H (width across flats)	Note 1) ϕD	L	P	A*	M	Effective area mm ²		Weight g
									TPH	TPS	
4	1/8	KPU04-01	12	10.4	45.4	10.4	41.5	18	7.5	7.5	7
	1/4	KPU04-02	14				49.4				43.5
6	1/8	KPU06-01	14	12.8	49.6	12.8	45.5	19.5	18	18	9
	1/4	KPU06-02	14				52.4				46.5
8	1/8	KPU08-01	17	15.2	56.7	15.2	52.5	21.5	26	26	15
	1/4	KPU08-02	17				61.3				55.5
10	1/4	KPU10-02	19	18.5	64.5	18.5	59	24	45	45	23
	3/8	KPU10-03					67.5				61.5
12	3/8	KPU12-03	22	20.9	69.7	20.9	63.5	25	70	70	29
	1/2	KPU12-04					72.7				65.5

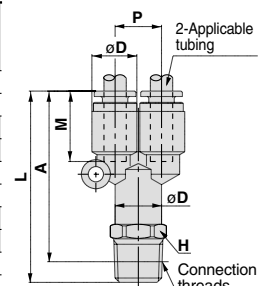

* Reference dimension for R threads after installation Note 1) ϕD indicates the maximum diameter.

Dimensions

Straight Union: KPH



Applicable tubing O.D. mm	Model	Note 1) ϕD	L	M	Effective area mm ²		Weight g
					TPH	TPS	
4	KPH04-00	10.4	37.4	18	4	4	4
6	KPH06-00	12.8	39.6	19.5	10	10	6
8	KPH08-00	15.2	44.4	21.5	26	18	10
10	KPH10-00	18.5	48.6	24	41	29	15
12	KPH12-00	20.9	50.6	25	58	46	18

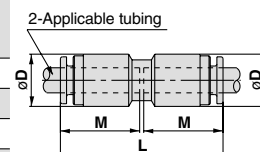

Note 1) ϕD indicates the maximum diameter.

Elbow: KPL



Applicable tubing O.D. mm	Model	Note 1) ϕD	L	Q	M	Effective area mm ²		Weight g
						TPH	TPS	
4	KPL04-00	10.4	20.7	4.5	18	3.5	3.5	3
6	KPL06-00	12.8	22.8	5.3	19.5	9	9	7
8	KPL08-00	15.2	26.3	6	21.5	22	15	11
10	KPL10-00	18.5	29.4	6.8	24	35	25	16
12	KPL12-00	20.9	31.4	7.5	25	50	40	20

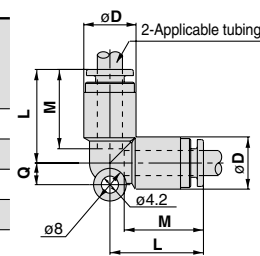

Note 1) ϕD indicates the maximum diameter.

Union Tee: KPT



Applicable tubing O.D. mm	Model	Note 1) ϕD	L	Q	M	Effective area mm ²		Weight g
						TPH	TPS	
4	KPT04-00	10.4	20.7	4.5	18	4	4	7
6	KPT06-00	12.8	22.8	5.3	19.5	10	10	9
8	KPT08-00	15.2	26.3	6	21.5	26	18	16
10	KPT10-00	18.5	29.4	6.8	24	41	29	25
12	KPT12-00	20.9	31.4	7.5	25	58	46	29

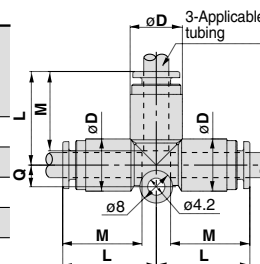

Note 1) ϕD indicates the maximum diameter.

Union "Y": KPU



Applicable tubing O.D. mm	Model	Note 1) ϕD	L ₁	L ₂	P	Q	M	Effective area mm ²		Weight g
								TPH	TPS	
4	KPU04-00	10.4	38.8	20.6	10.4	9.7	18	4	4	7
6	KPU06-00	12.8	42.1	22.8	12.8	11.7	19.5	10	10	10
8	KPU08-00	15.2	48.7	27.5	15.2	13.7	21.5	26	18	17
10	KPU10-00	18.5	54	30.7	18.5	16.1	24	41	29	26
12	KPU12-00	20.9	57.2	32.9	20.9	18.1	25	58	46	32

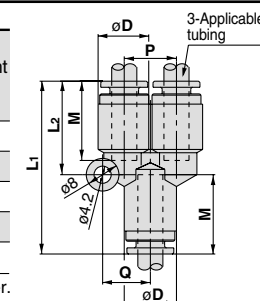

Note 1) ϕD indicates the maximum diameter.

Plug-in Reducer: KPR



Applicable tubing O.D. mm	Applicable fitting size ϕd	Model	Note 1) ϕD	L	A	M	Effective area mm ²		Weight g
							TPH	TPS	
4	6	KPR04-06	10.4	39.4	20.1	18	4	4	3
	8	KPR04-08		41.9	20.2				4
6	10	KPR06-08	12.8	42.5	20.8	19.5	10	10	4
		KPR06-10		45	21.2				5
8	12	KPR08-10	15.2	47	23.2	21.5	26	18	5
		KPR08-12		48	23.2				6
10		KPR10-12	18.5	50.5	25.7	24	41	29	9

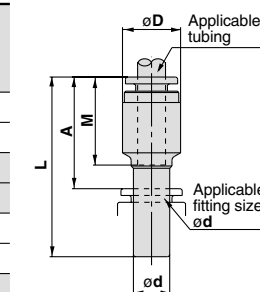

Note 1) ϕD indicates the maximum diameter.

Plug: KPP



Applicable fitting size ϕd	Model	ϕD	L	A	Weight g
4	KPP-04	6	32	13.8	0.4
6	KPP-06	8	35	15.7	0.7
8	KPP-08	10	39	17.3	1.1
10	KPP-10	12	43	19.2	1.7
12	KPP-12	14	45.5	20.7	2.5

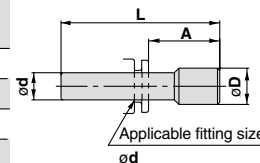

K□

M□

H□

D□

MS

T□

VMG



Series KP/KPQ/KPG

Specific Product Precautions 1

Be sure to read before handling.

Selection

⚠ Caution

1. Do not use in locations where the connecting threads and tubing connection will slide or rotate. The connecting threads and tubing connection will come apart under these conditions.
2. Use tubing at or above the minimum bending radius. Using below the minimum bending radius can cause breakage or flattening of the tube.
3. Please consult with SMC regarding fluids other than air, water and nitrogen gas.
4. In the case of liquid fluids, keep surge pressure at or below the maximum operating pressure. If the surge pressure exceeds the maximum operating pressure, this can cause damage to the fittings and tubing.

Handling

⚠ Caution

1. Store away from direct sunlight at 40°C or less.
2. Open the inner package of double packaging in a clean room or other clean environment.

Mounting

⚠ Caution

1. Before mounting confirm the model and size, etc. Also, confirm that there are no blemishes, nicks or cracks in the product.
2. When tubing is connected, consider factors such as changes in the tubing length due to pressure, and allow sufficient leeway.
3. Mount so that fittings and tubing are not subjected to twisting, pulling or moment loads. This can cause damage to fittings and flattening, bursting or disconnection of tubing, etc.
4. Mount so that tubing is not damaged due to tangling and abrasion. This can cause flattening, bursting or disconnection of tubing, etc.

Installation of Threads

⚠ Caution

Be sure to wrap sealing tape around the taper threads for both resin and metal threads.

If used without sealing tape air leakage can occur.

1. Series KP (with resin thread)
 - 1) Wrapping of pipe tape
Wrap the pipe tape 2 to 3 times around the threads, leaving 1.5 to 2 thread ridges exposed at the end of the threads.
 - 2) Tightening
After tightening by hand, tighten an additional 2 to 3 turns using a tightening tool.

Installation of Threads

⚠ Caution

2. Series KPQ/KPG (with metal thread)
 - 1) For M5
After tightening by hand, tighten approximately 1/6 turn further using a tightening tool. Excessive tightening can cause air leakage due to thread damage or deformation of the gasket, etc. Insufficient tightening can cause loose threads and air leakage, etc.
 - 2) Taper thread
 - (1) Wrapping of pipe tape
Wrap the pipe tape 2 to 3 times around the threads, leaving 1.5 to 2 thread ridges exposed at the end of the threads.
 - (2) When installing, tighten with the proper torque shown in the table below. As a rule, this corresponds to two or three turns with a tool after tightening by hand.

Connection thread size	Proper tightening torque
R 1/8	7 to 9
R 1/4	12 to 14
R 3/8	22 to 24
R 1/2	28 to 30

3. Tightening tools
Tighten with an appropriate wrench using the hexagon wrench flats on the body.
Position the wrench on the base as close as possible to the threads. If the size of the wrench is not suitable for the hexagon wrench flats, the wrench flats may be crushed.

Installation and Removal of Tubing

⚠ Caution

1. Installation of tubing
 - 1) Using tube cutters TK-1, 2 or 3, take a tube having no flaws on its periphery and cut it off at a right angle. Do not use pinchers, nippers or scissors, etc. The tubing might be cut diagonally or flattened, making installation impossible or causing problems such as disconnection and leakage.
 - 2) Hold the tube and push it in slowly, inserting it securely all the way into the fitting.
 - 3) After inserting the tubing, pull on it lightly to confirm that it will not come out. If it is not installed securely all the way into the fitting, problems such as leakage or disconnection of the tubing can occur.
 - 4) Grease is not used due to the Series KP oil-free specifications. For this reason, greater insertion force is required when tubing is installed. In particular, polyurethane tubing may fold when inserted due to its softness. Hold the end of the tubing, and insert it all the way in slowly and securely. Refer to dimension "M" in the dimension drawings for guidance on the insertion depth of tubing.

K□

M□

H□

D□

MS

T□

VMG



Series KP/KPQ/KPG

Specific Product Precautions 2

Be sure to read before handling.

Installation and Removal of Tubing

Caution

2. Removal of tubing
 - 1) Push in the release button sufficiently, pressing the collar evenly around its circumference.
 - 2) Pull out the tubing while holding down the release button so that it does not pop out. If the release button is not pressed down sufficiently, there will be increased bite on the tubing and it will become more difficult to pull it out.
 - 3) When the removed tubing is to be used again, first cut off the section of the tubing which has been chewed. Using the chewed portion of the tube as it is can cause problems such as leakage or difficulty in removing the tubing.

Operating Environment

Warning

1. Do not use in environments or locations where there is a danger of damage to fittings and tubing.
For fitting and tubing materials, refer to specifications and construction drawings, etc.
2. Provide shade in locations which receive direct sunlight.
3. Do not operate in locations where vibration or impact occurs.
Since this can cause leakage and fitting damage, etc., please contact SMC regarding use in this kind of environment.
4. Provide shielding in locations near heat sources.
When there are heat sources in the surrounding area, the product's temperature may rise due to radiated heat and exceed its operating temperature range. Block off the heat with a cover, etc.
5. Do not use in locations where static electric charges will be a problem. Please consult with SMC regarding use in this kind of environment.
6. Do not use in locations where spatter occurs.
There is a danger of spatter causing a fire. Please consult with SMC regarding use in this kind of environment.

Caution

1. Series KP are special One-touch fittings for use on clean blowing and washing lines. Please consult with SMC regarding other types of applications.
Seal material: The durability of EPDM with respect to mineral oils is inferior, making it unsuitable for piping in general pneumatic equipment.
Use Series KPQ and KPG for piping to general pneumatic equipment.

Maintenance

Caution

1. Pre-maintenance inspection
When the product is to be removed, turn off the electric power, and be sure to cut off the supply pressure and confirm that fluid in the piping has been discharged.
2. Post maintenance inspection
After remounting and connection of piping, restore the fluid and electric power, and perform suitable function and leak tests. If leakage occurs or the equipment does not operate properly, stop operation immediately and confirm whether it is mounted correctly.
3. Tightening of blow fittings (resin taper threads for piping)
Since Series KP taper threads are made of resin, minute leakage may gradually occur due to stress relaxation. Perform periodic inspections, and if leakage is detected correct the problem by further tightening. If additional tightening becomes ineffective, replace the fitting with a new product.
4. Check for the following during regular maintenance, and replace components as necessary.
 - a) Scratches, gouges, abrasion, corrosion
 - b) Leakage, refer to item 3 regarding taper thread leakage.
 - c) Twisting, flattening or distortion of tubing
 - d) Hardening, deterioration or softness of tubing
5. Do not repair or patch the replaced tubing or fittings for reuse.

Precaution on Use of Other Tubing Brands

Caution

1. When using tubing brands other than SMC, confirm that the tubing outside diameter tolerances satisfy the following specifications.

1) Polyolefin tubing	±0.1 mm
2) Polyurethane tubing	+0.15 mm -0.2 mm
3) Nylon tubing	±0.1 mm
4) Soft nylon tubing	±0.1 mm

Do not use tubing if the outside diameter tolerance is not satisfied. It may not be possible to connect the tubing, or leakage or disconnection may occur after connection.

Polyolefin tubing is recommended for use with clean room fittings. Note that while other types of tubing will satisfy performance standards for leakage and tubing pull-out strength, etc., the degree of cleanliness will deteriorate.