



Contact our sales office for delivery dates and prices since this is a special model.

SP157X-014E
P TY



P.G.Information (Specialized Product)

Step motor (Servo 24 DC) Absolute Controller LECP7-XB3 Series

SMC Corporation
4-14-1, SOTO-KANDA,
CHIYODA-KU,
101-0021, JAPAN
URL: <http://www.smcworld.com>

- Return to origin not required after power is OFF/Shorten equipment recovery time

◎ The current actuator position can be monitored even if the power of the battery is shutoff

◎ The position signal can be monitored immediately after the power is shutoff even if the actuator is operated at high speed.

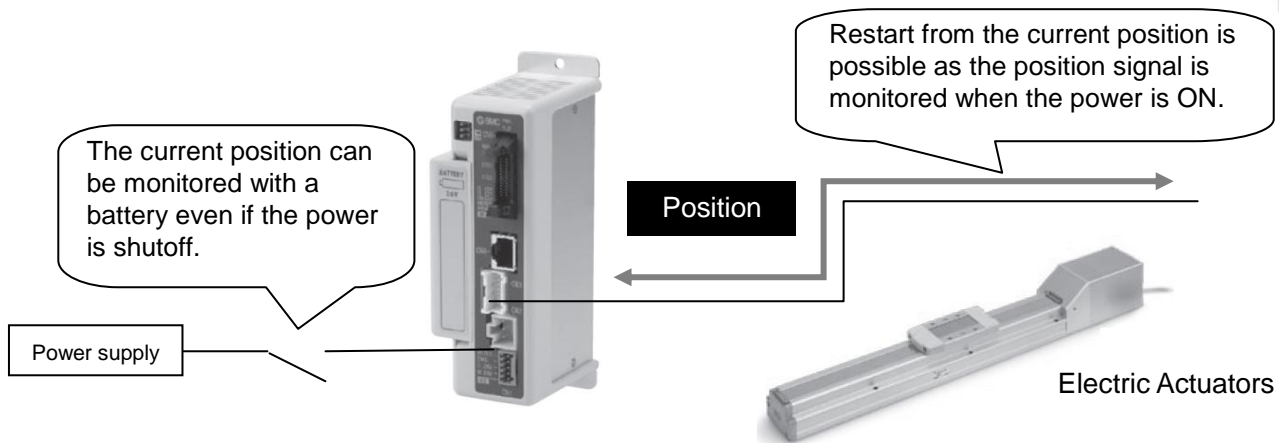

- Duration of position data retention: Maximum 20 days
- Space saving
 - ◎ Integration of absolute function (battery) and controller
- Applicable actuators

The step motor (servo DC24V) is mounted to applicable actuators. Please refer to the table below.

Electric Gripper	LEH Series
Electric Slide Table	LES Series
Electric Actuator / Rod Type	LEY Series
Electric Actuator / Slider Type	LEF Series (H lead is excluded)
Electric Rotary Table	LER Series (LER*-1*-* is excluded)
Electric Actuator/ Miniature Rod, Miniature Slider Table Type	LEPY/LEPS Series

* When an actuator is selected, please confirm workload, speed and a graph of the speed and workload when a pulse input driver (LECPA) is used that is shown in Best Pneumatics (actuator).

How to Order:

LECP7 N 1 — — **XB3**

(1) (2) (3) (4)

(1) Parallel I/O type

N	NPN
P	PNP

(3) Option

Nil	Screw mounting
D	DIN rail mounting

(2) I/O cable length

Nil	Without cable
1	1.5m
3	3m
5	5m

(4) Actuator part number

Part number except cable specifications and actuator options
 Example : Enter "LEFS16B-100B-R1"
 for the 「LECP7**-LEFS16B-100」

Dimensions

Screw mounting (LECP7***-*-XB3)

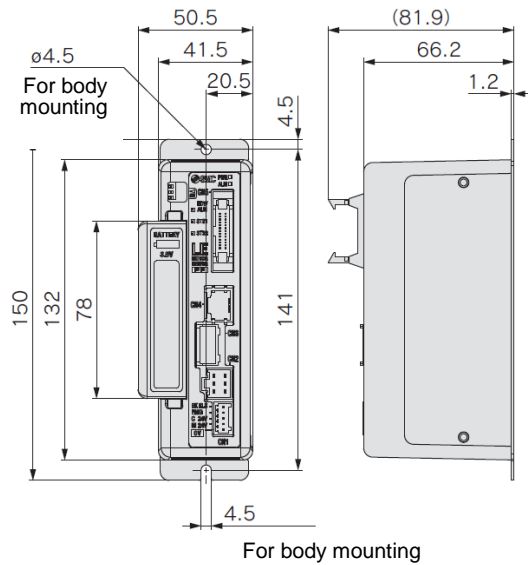

DIN rail mounting (LECP7**D-*-XB3)

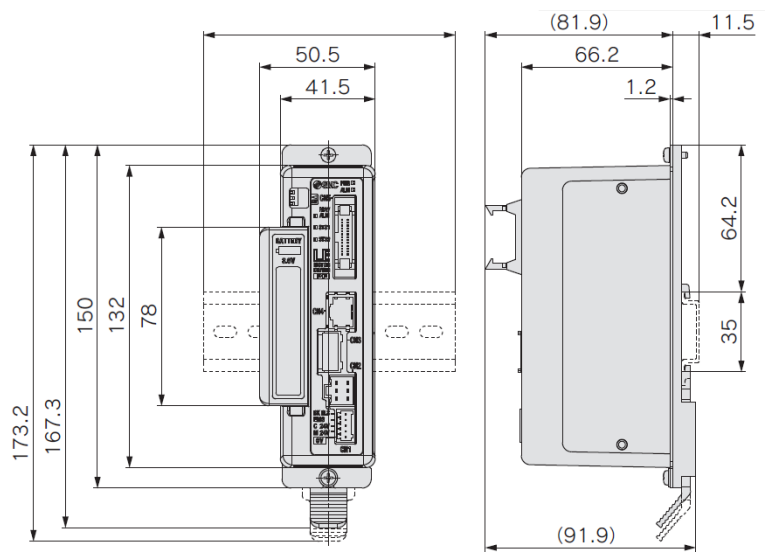

Specifications

Item		Specifications:			
Compatible motor		Step motor (Servo/24 VDC)			
Power supply ^{Note 1)}		Power voltage: 24 VDC \pm 10% Note 2) [Including motor drive power, control power, stop, lock release]			
Number of positioning points		64 points			
Parallel input		11 inputs			
Parallel output		13 outputs			
Compatible encoder		Incremental A/B phase (800 pulse/rotation)			
Serial communication		RS485 (Modbus protocol compliant)			
Memory		EEPROM			
Lock control		Forced-lock release terminal			
Cable length [m]		I/O cable: 5 or less, Actuator cable: 20 or less			
Battery		Nickel hydride secondary battery 3.6V Charging time: 72 hours			
Battery replacement guide (Note 3)		2 years			
Battery retention condition/period Note 4) 5)	Motor allowable RPM when power supply is shutoff [rpm]	800	400	200	100
	Duration guide of retention (day)	2	5	10	20
Cooling system		Natural air cooling			
Operating temperature range [°C] ^{Note 6)}		Screw mounting: 0 to 40 (No freezing) Screw mounting: 0 to 30 (No freezing)			
Operating humidity range [%RH] ^{Note 7)}		90 or less (No condensation)			
Insulation resistance [MΩ]		Between the housing and SG terminal: 50 (500 VDC)			
Weight (including batteries) [g]		410g (Screw mounting) 430g (DIN rail mounting)			

Note 1) Do not use the inrush current prevention type power supply for the controller input power supply.

Note 2) The power consumption depends on the actuator. Refer to the actuator specifications for more details.

Note 3) The temperature is 20°C (8hrs/day). When operating temperature rises, battery performance deteriorates and the period for battery replacement shortens.

Note 4) This is a guide for normal temperatures (20°C). If the operating temperature is higher or lower than this, the retention period will be shorter.

Note 5) This is the period in which the position can be monitored with a battery when the power supply is shutoff.

This retention period depends on the allowable RPM setting when the power supply is shutoff.

Note 6) Use at a temperature of 20°C is recommended.

Note 7) Please use the product so that static electricity is not generated.



LECP7-XB3 Series / Specific Product Precautions

Be sure to read before using. Refer to the SMC website for Safety Instructions, and the Operation Manual for Electric Actuator Precautions.

Compliance requirements

- **This product is compliant with Japanese laws and regulations only.**
- **Please be sure that the product is compliant with the local laws and regulations for each country or area when the product is exported.**
- **This product uses a nickel hydride battery.**
- **Nickel hydride batteries is considered a dangerous good (Class 9) for maritime transport according to UN regulations.**

This product is NOT considered a dangerous good for maritime transport (as of August 2012).

When nickel hydride batteries and equipment including nickel hydride batteries are transported by a transportation method applicable to UN regulations, the transport conditions should be compliant with regulations, such as the United Nations Recommendations on the Transport of Dangerous Goods, the engineering guideline (ICAO-TI) of the International Civil Aviation Organization (ICAO) and the regulations of the International Maritime Dangerous Goods Code (IMDG CODE) of the International Maritime Organization (IMO). When customers transport the product themselves, they are required to confirm the latest standards, laws and regulations of the destination countries.

- **This product is available in SMC sales branches of Japan and the United States.**

This product is NOT available in SMC sales branches of other subsidiaries.

Handling

[Long-term storage]

- **If the product is stored in a back-up state for a long period, the capacity characteristics after storage will decrease.**

Liquid leakage, deterioration of functions and an extreme decrease in battery life may occur by the effects of a natural discharge.

[Scrapping products]

- **Please recycle used batteries.**

Please wrap the connector of the batteries for insulation before recycling. Please be sure to be compliant with the laws and regulations in your country for recycling, collection and scrapping products.

Recyclable marking

Europe	Secondary battery

[When a controller is used for the first time]

- **An alarm will sound 2 times when a battery is connected for the first time. Refer to the Operation Manual for details.**
- **When power is supplied to the controller for the first time, please charge the battery for more than 72 hours.**
- **Refer to the Instruction Manual for the signal and wiring.**



Caution To ensure the safest possible operation of this product, please be sure to thoroughly read the "Safety Instructions" in our "Best Pneumatics" catalog before use.