



**Step Motor Controller
(Servo/24 VDC)**

Series LECP6



**Servo Motor Controller
(24 VDC)**

Series LECA6

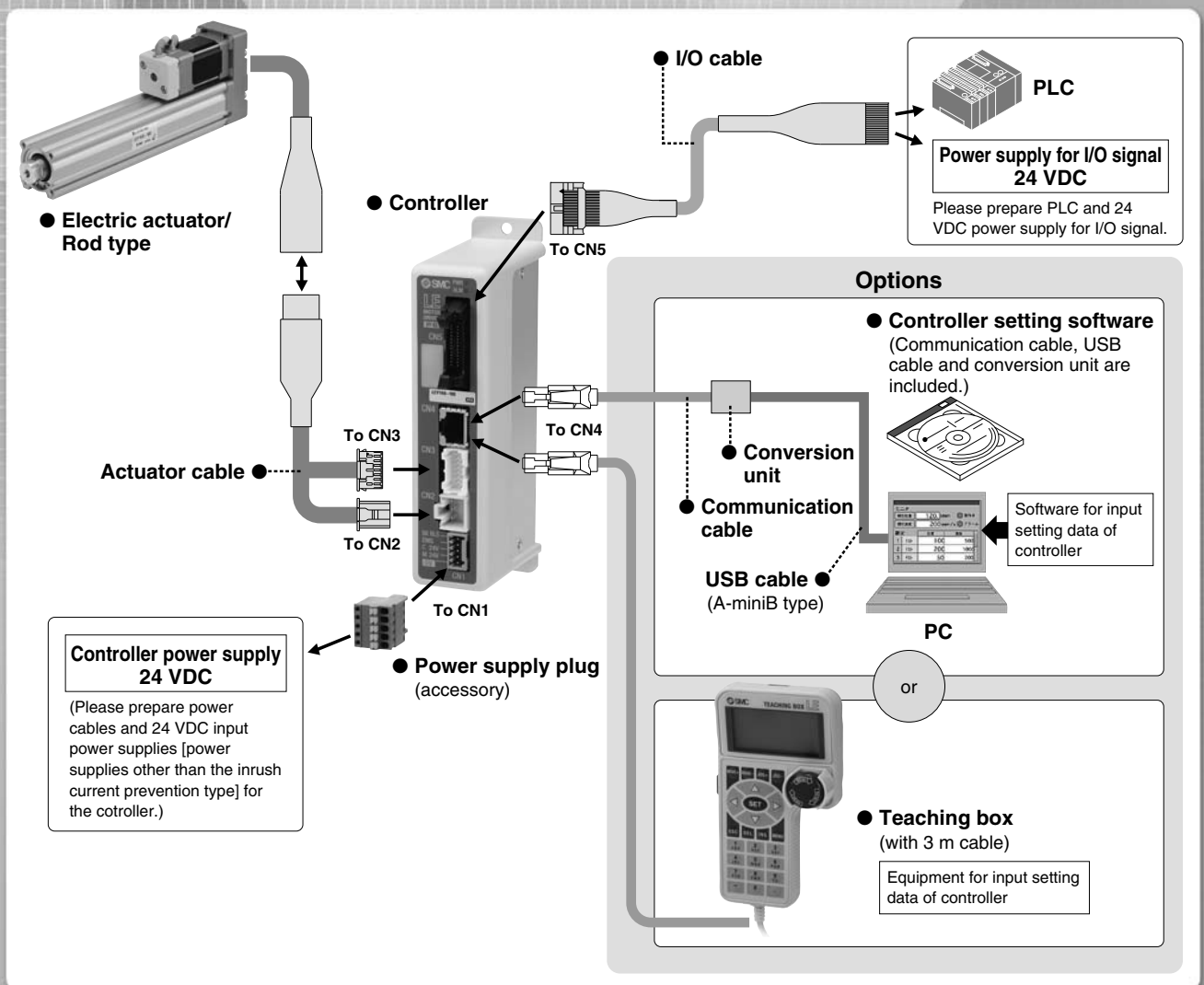

Step Motor Controller (Servo/24 VDC)

Series **LECP6**

Servo Motor Controller (24 VDC)

Series **LECA6**



Series **LECP6** Series **LECA6**

How to Order

⚠ Caution

Note 1) CE-compliant products

① EMC compliance was tested by combining the electric actuator LEY series and the controller LEC series. The EMC depends on the configuration of the customer's control panel and the relationship with other electrical equipment and wiring. Therefore conformity to the EMC directive cannot be certified for SMC components incorporated into the customer's equipment under actual operating conditions. As a result it is necessary for the customer to verify conformity to the EMC directive for the machinery and equipment as a whole.

② For the LECA6 series (servo motor controller), EMC compliance was tested by installing a noise filter set (LEC-NFA). Refer to page 26 for the noise filter set. Refer to the LECA Operation Manual for installation.

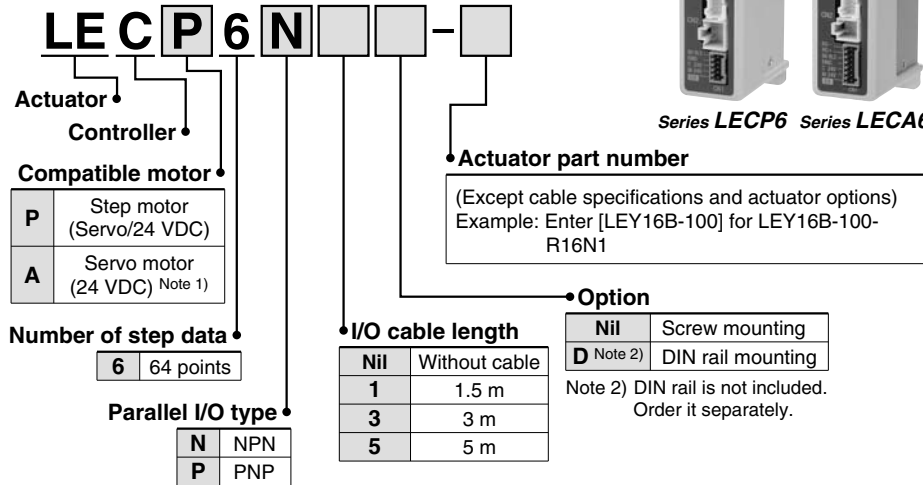

* When controller equipped type (-P6□□) is selected when ordering the LE series, you do not need to order this controller.

The controller is sold as single unit after the compatible actuator is set.

Confirm that the combination of the controller and the actuator is compatible.

<Be sure to check the following before use.>

- ① Check that actuator label for model number. This matches the controller.
- ② Check Parallel I/O configuration matches (NPN or PNP).

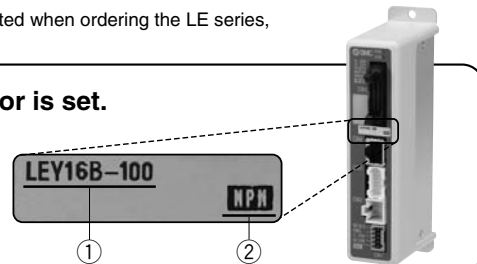

Specifications

Basic Specifications

Item	LECP6	LECA6
Compatible motor	Unipolar connection type 2-phase HB step motor	AC servo motor
Power supply <i>Note 1)</i>	Power voltage: 24 VDC ±10% Current consumption: 3 A (Peak 5 A) <i>Note 2)</i> [Including motor drive power, control power, stop, lock release]	Power voltage: 24 VDC ±10% Current consumption: 3 A (Peak 10 A) <i>Note 2)</i> [Including motor drive power, control power, stop, lock release]
Parallel input	11 inputs (Photo-coupler isolation)	
Parallel output	13 outputs (Photo-coupler isolation)	
Compatible encoder	A/B phase, Line receiver input Resolution 800 p/r	A/B/Z phase, Line receiver input Resolution 800 p/r
Serial communication	RS485 (Modbus protocol compliant)	
Memory	EEPROM	
LED indicator	LED (Green/Red) one of each	
Lock control	Forced-lock release terminal	
Cable length (m)	I/O cable: 5 or less Actuator cable: 20 or less	
Cooling system	Natural air cooling	
Operating temperature range (°F)	32 to 104 (No condensation and freezing)	
Operating humidity range (%)	35 to 85 (No condensation and freezing)	
Storage temperature range (°F)	14 to 140 (No condensation and freezing)	
Storage humidity range (%)	35 to 85 (No condensation and freezing)	
Insulation resistance (MΩ)	Between the housing (radiation fin) and SG terminal 50 (500 VDC)	
Weight (lb)	0.3 (Screw mounting) 0.4 (DIN rail mounting)	

Note 1) Do not use the power supply of "inrush current prevention type" for the controller power supply.

Note 2) The power consumption changes depending on the actuator model. Refer to the specifications of actuator for more details.

How to Mount

a) Screw mounting (LEC□6□□-□) (Installation with two M4 screws)

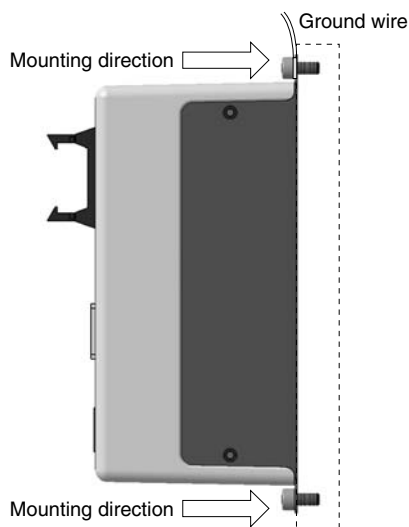

b) DIN rail mounting (LEC□6□□D-□) (Installation with the DIN rail)

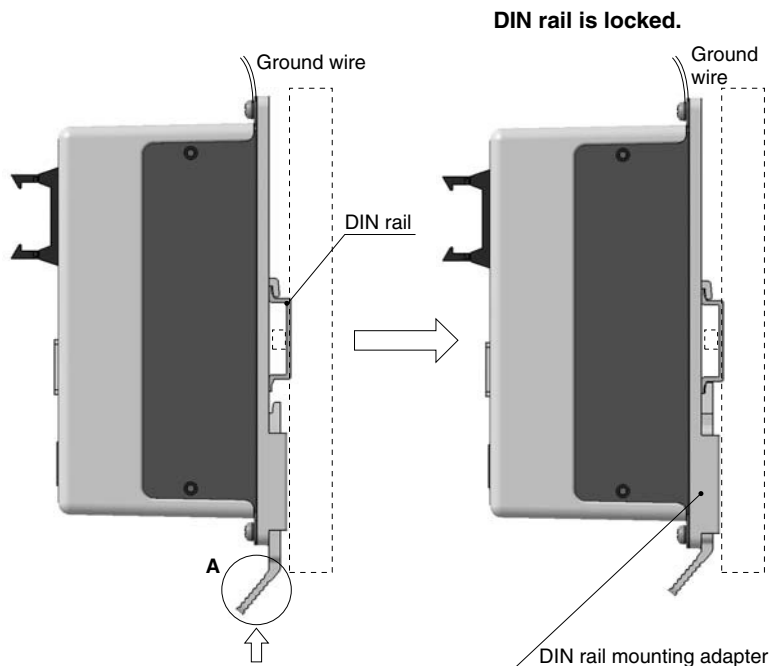

Hook the controller on the DIN rail and press the lever of section A in the arrow direction to lock it.

DIN rail AXT100-DR-□

* For □, enter a number from the "No." line in the below table.
 Refer to the dimensions on page 20 for the mounting dimensions.

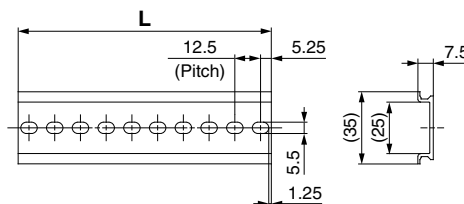

L Dimensions

No.	1	2	3	4	5	6	7	8	9	10	11	12	13	14	15	16	17	18	19	20
L dimension	23	35.5	48	60.5	73	85.5	98	110.5	123	135.5	148	160.5	173	185.5	198	210.5	223	235.5	248	260.5
No.	21	22	23	24	25	26	27	28	29	30	31	32	33	34	35	36	37	38	39	40
L dimension	273	285.5	298	310.5	323	335.5	348	360.5	373	385.5	398	410.5	423	435.5	448	460.5	473	485.5	498	510.5

DIN rail mounting adapter LEC-D0 (with 2 mounting screws)

This should be used when the DIN rail mounting adapter is mounted onto the screw mounting type controller afterwards.

Series LECP6

Series LECA6

Dimensions

a) Screw mounting (LECP6□□□-□)

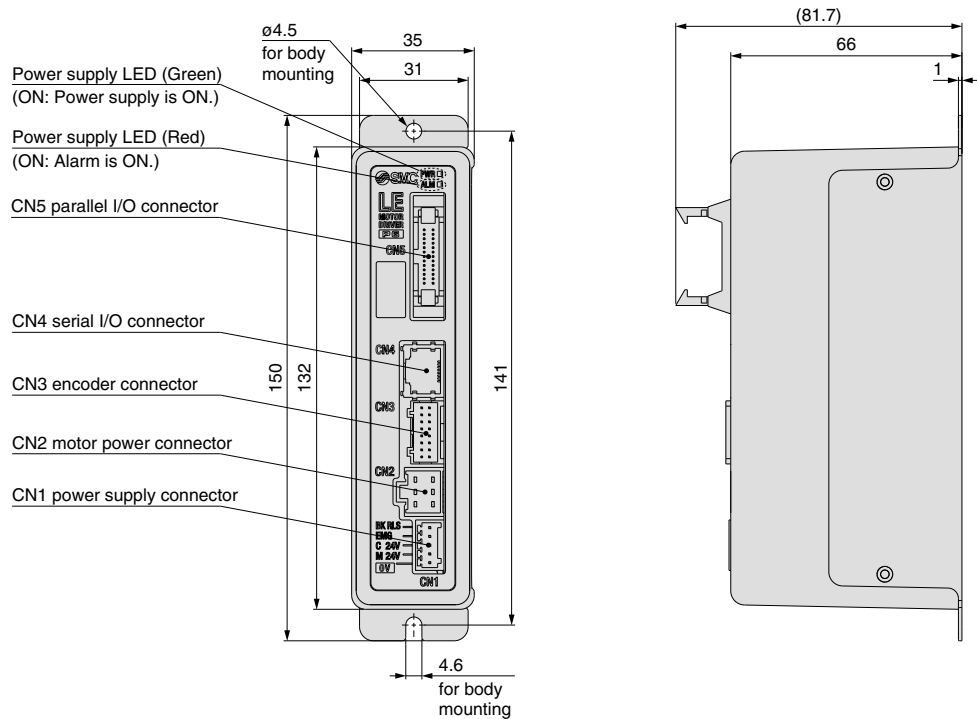

b) DIN rail mounting (LECP6□□□D-□)

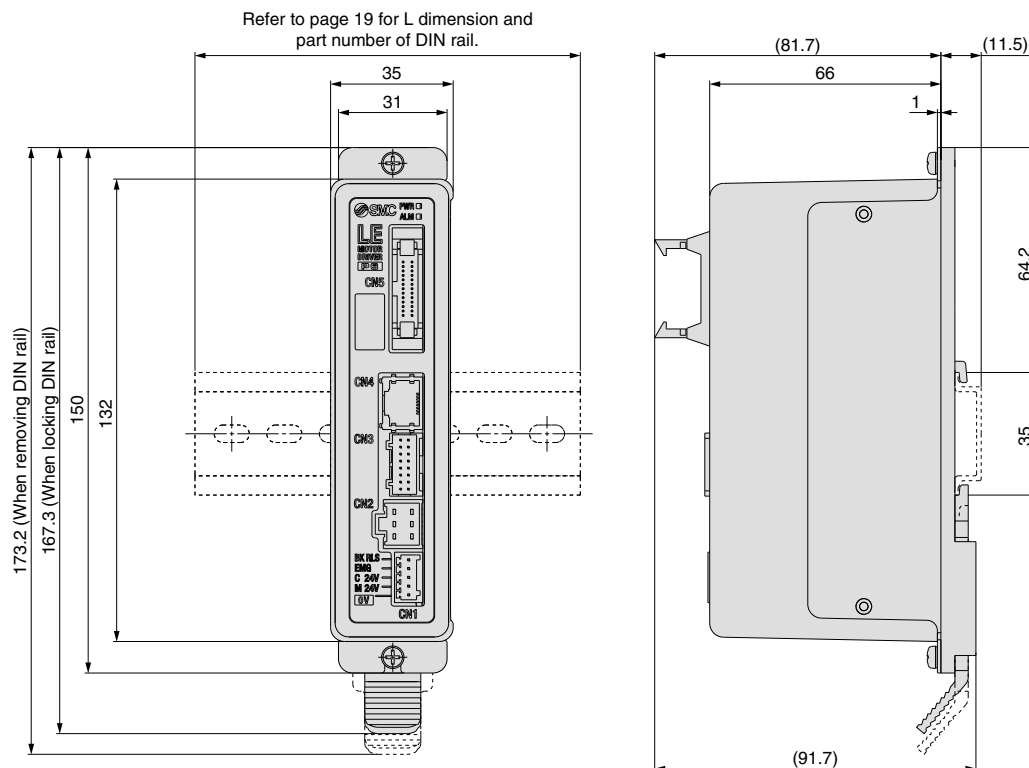

Note) When two or more controllers are used, keep the interval between them 10 mm or more (when the LEY25, 32 are used).

Wiring Example 1

Power Supply Connector: CN1 * Power supply plug is an accessory.

CN1 Power Supply Connector Terminal for LECP6 (Phoenix Contact FK-MC0.5/5-ST-2.5)

Terminal name	Function	Function details
0V	Common supply (-)	M24V terminal/C24V terminal/EMG terminal/BK RLS terminal are common (-).
M24V	Motor power supply (+)	This is the motor power supply (+) that is supplied to the controller.
C24V	Control power supply (+)	This is the control power supply (+) that is supplied to the controller.
EMG	Stop (+)	This is the input (+) that releases the stop.
BK RLS	Lock release (+)	This is the input (+) that releases the lock.

Power supply plug for LECP6

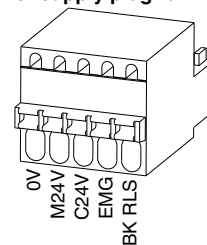

CN1 Power Supply Connector Terminal for LECA6 (Phoenix Contact FK-MC0.5/7-ST-2.5)

Terminal name	Function	Function details
0V	Common supply (-)	M24V terminal/C24V terminal/EMG terminal/BK RLS terminal are common (-).
M24V	Motor power supply (+)	This is the motor power supply (+) that is supplied to the controller.
C24V	Control power supply (+)	This is the control power supply (+) that is supplied to the controller.
EMG	Stop (+)	This is the input (+) that releases the stop.
BK RLS	Lock release (+)	This is the input (+) that releases the lock.
RG+	Regenerative output 1	These are the regenerative output terminals for external connection. (It is not necessary to connect them in the combination with standard specification LEY series.)
RG-	Regenerative output 2	

Power supply plug for LECA6

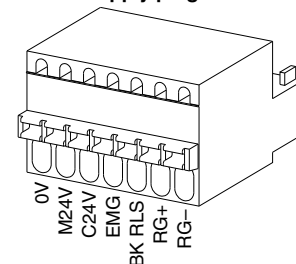

Wiring Example 2

Parallel I/O Connector: CN5 * When you connect a PLC, etc., to the CN5 parallel I/O connector, please use the I/O cable (LEC-CN5-□).
 * The wiring should be changed depending on the type of the parallel I/O (NPN or PNP). Please wire referring to the following diagram.

Wiring diagram

LEC□6N□□-□ (NPN)

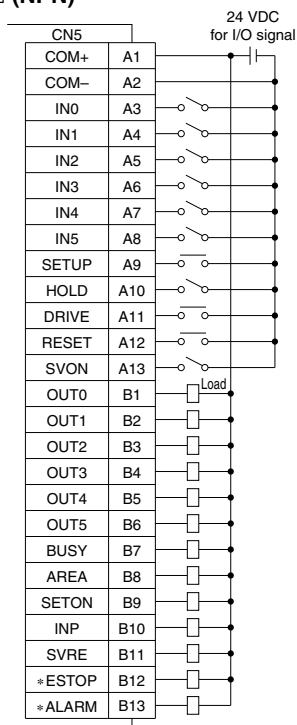

LEC□6P□□-□ (PNP)

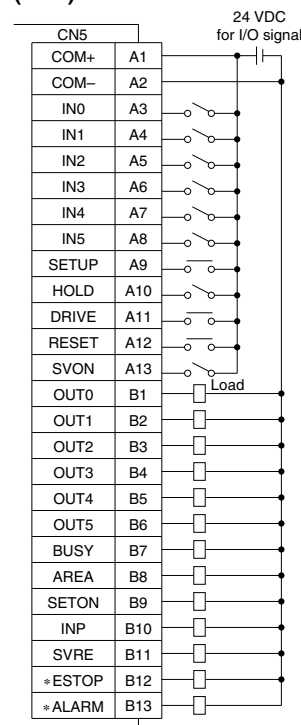

Input Signal

Name	Contents
COM+	Connects the power supply 24 V for input/output signal
COM-	Connects the power supply 0 V for input/output signal
IN0 to IN5	Step data specified Bit No. (Input is instructed in the combination of IN0 to 5.)
SETUP	Instruction to return to the original position
HOLD	Operation is temporarily stopped.
DRIVE	Instruction to drive
RESET	Alarm reset and operation interruption
SVON	Servo ON instruction

Output Signal

Name	Contents
OUT0 to OUT5	Outputs the step data No. during operation
BUSY	Outputs when the actuator is moving
AREA	Outputs within the step data area output setting range
SETON	Outputs when returning to the original position
INP	Outputs when target position or target force is reached (Turns on when the positioning or pushing is completed.)
SVRE	Outputs when servo is on
*ESTOP (Note)	Not output when EMG stop is instructed
*ALARM (Note)	Not output when alarm is generated

Note) These signals are output when the power supply of the controller is ON. (N.C.)

Series LECP6

Series LECA6

Step Data Setting

1. Step data setting for positioning

In this setting, the actuator moves toward and stops at the target position. The following diagram shows the setting items and operation. The setting items and set values for this operation are stated below.

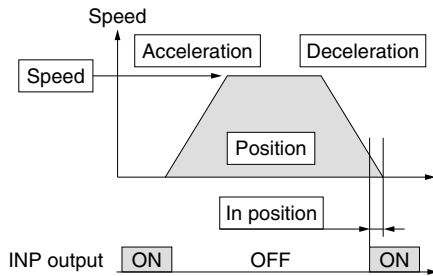

⊙: Need to be set.
 ○: Need to be adjusted as required.
 —: Setting is not required.

Step Data (Positioning)

Necessity	Item	Description
⊙	Movement MOD	When the absolute position is required, set Absolute. When the relative position is required, set Relative.
⊙	Speed	Transfer speed to the target position
⊙	Position	Target position
○	Acceleration	Parameter which defines how rapidly the actuator reaches the speed set. The higher the set value, the faster it reaches the speed set.
○	Deceleration	Parameter which defines how rapidly the actuator comes to stop. The higher the set value, the quicker it stops.
⊙	Pushing force	Set 0. (If values 1 to 100 are set, the operation will be changed to the pushing operation.)
—	Trigger LV	Setting is not required.
—	Pushing speed	Setting is not required.
○	Positioning force	Max. torque during the positioning operation (No specific change is required.)
○	Area 1, Area 2	Condition that turns on the AREA output signal.
○	In position	Condition that turns on the INP output signal. When the actuator enters the range of [in position], the INP output signal turns on. (It is unnecessary to change this from the initial value.) When it is necessary to output the arrival signal before the operation is completed, make the value larger.

2. Step data setting for pushing

The actuator moves toward the pushing start position, and when it reaches that position, it starts pushing with less than the set force. The following diagram shows the setting items and operation. The setting items and set values for this operation are stated below.

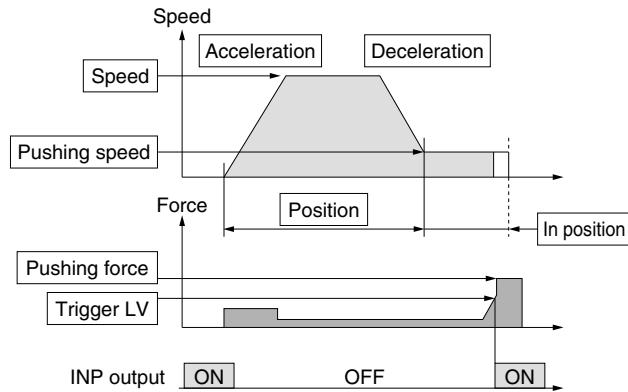

⊙: Need to be set.
 ○: Need to be adjusted as required.

Step Data (Pushing)

Necessity	Item	Description
⊙	Movement MOD	When the absolute position is required, set Absolute. When the relative position is required, set Relative.
⊙	Speed	Transfer speed to the pushing start position
⊙	Position	Pushing start position
○	Acceleration	Parameter which defines how rapidly the actuator reaches the speed set. The higher the set value, the faster it reaches the speed set.
○	Deceleration	Parameter which defines how rapidly the actuator comes to stop. The higher the set value, the quicker it stops.
⊙	Pushing force	Pushing force ratio is defined. The setting range differs depending on the electric actuator type. Refer to the operation manual for the electric actuator.
⊙	Trigger LV	Condition that turns on the INP output signal. The INP output signal is turned on when the generated force exceeds the value. Threshold level should be less than the pushing force.
○	Pushing speed	Pushing speed When the speed is set fast, the electric actuator and work pieces might be damaged due to the impact when they hit the end, so this set value should be smaller. Refer to the operation manual of the electric actuator.
○	Positioning force	Max. torque during the positioning operation (No specific change is required.)
○	Area 1, Area 2	Condition that turns on the AREA output signal.
⊙	In position	Transfer distance during pushing. If the transferred distance exceeds the setting, it stops even if it is not pushing. If the transfer distance is exceeded, the INP output signal will not be turned on.

Signal Timing

Return to Origin

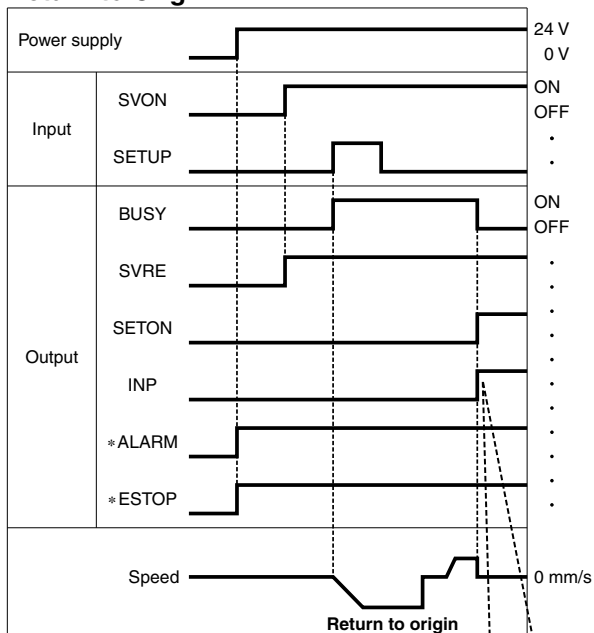

If the actuator is within the "in position" range of the basic parameter, INP will be turned ON, but if not, it will remain OFF.

* *ALARM" and *ESTOP" are expressed as negative-logic circuit.

Positioning Operation

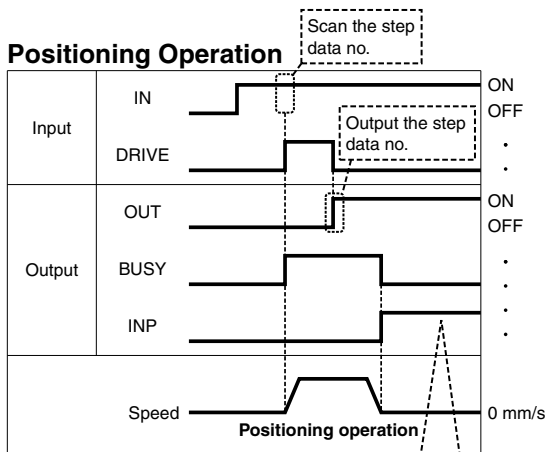

If the actuator is within the "in position" range of the step data, INP will be turned ON, but if not, it will remain OFF.

* "OUT" is output when "DRIVE" is changed from ON to OFF.
 (When power supply is applied, "DRIVE" or "RESET" is turned ON or *ESTOP" is turned OFF, all of the "OUT" outputs are turned OFF.)

Pushing Operation

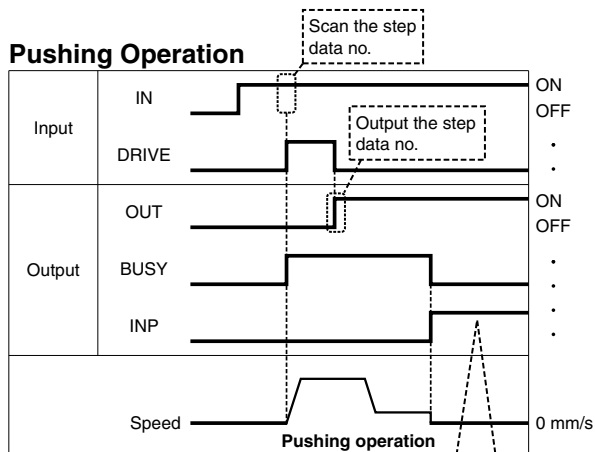

If the current pushing force exceeds the "threshold level" of the step data, INP signal will be turned ON.

HOLD

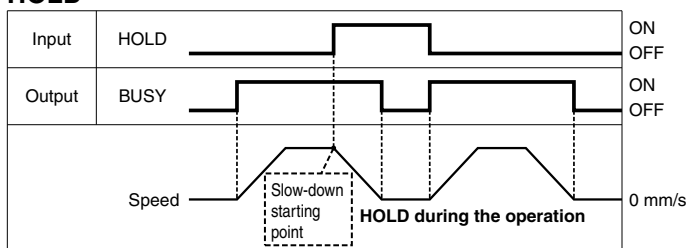

* When the actuator is in the positioning range in the pushing operation, it does not stop even if HOLD signal is input.

Reset

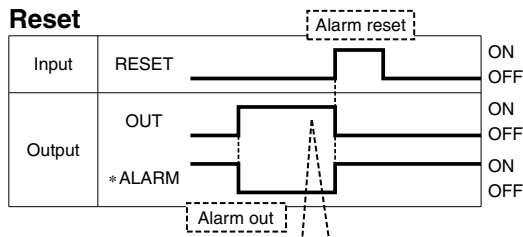

It is possible to identify the alarm group by the combination of OUT signals when the alarm is generated.

* *ALARM" and *ESTOP" are expressed as negative-logic circuit.

Series LECP6

Series LECA6

Options

[Actuator cable for step motor (Servo/24 VDC)]

LE-CP-1

Cable length (L)

1	1.5 m
3	3 m
5	5 m
8	8 m*
A	10 m*
B	15 m*
C	20 m*

* Produced upon receipt of order

LE-CP-¹/₃ / Cable length: 1.5 m, 3 m, 5 m

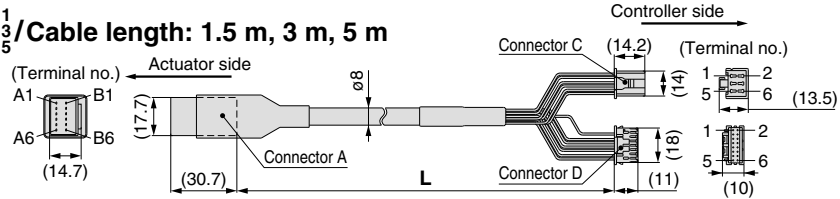

LE-CP-^{8B}/_{AC} / Cable length: 8 m, 10 m, 15 m, 20 m
(* Produced upon receipt of order)

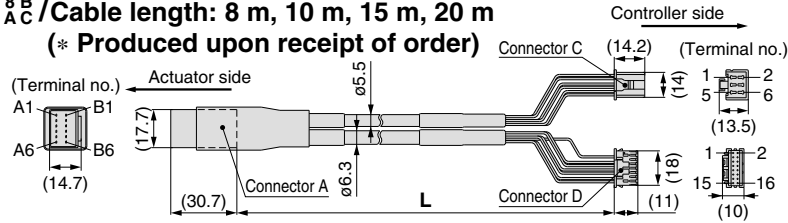

Circuit	Connector A terminal no.	Cable color	Connector C terminal no.
A	B-1	Brown	2
A	A-1	Red	1
B	B-2	Orange	6
B	A-2	Yellow	5
COM-A/COM	B-3	Green	3
COM-B/-	A-3	Blue	4
Shield			
Vcc	B-4	Brown	12
GND	A-4	Black	13
A	B-5	Red	7
A	A-5	Black	6
B	B-6	Orange	9
B	A-6	Black	8
		—	3

[Actuator cable with lock and sensor for step motor (Servo/24 VDC)]

LE-CP-1-B

Cable length (L)

1	1.5 m
3	3 m
5	5 m
8	8 m*
A	10 m*
B	15 m*
C	20 m*

* Produced upon receipt of order

With lock and sensor

LE-CP-¹/₃ / Cable length: 1.5 m, 3 m, 5 m

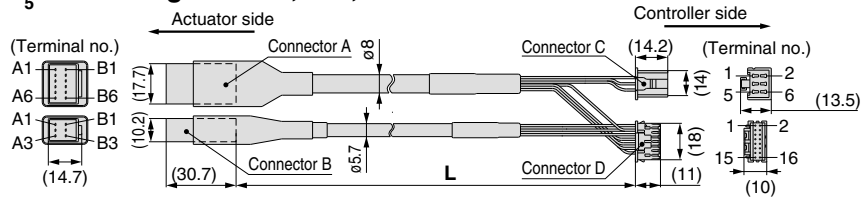

LE-CP-^{8B}/_{AC} / Cable length: 8 m, 10 m, 15 m, 20 m (* Produced upon receipt of order)

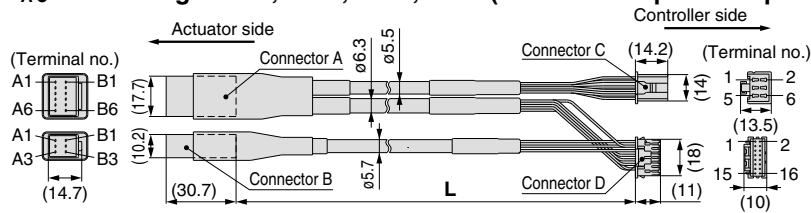

Circuit	Connector A terminal no.	Cable color	Connector C terminal no.
A	B-1	Brown	2
A	A-1	Red	1
B	B-2	Orange	6
B	A-2	Yellow	5
COM-A/COM	B-3	Green	3
COM-B/-	A-3	Blue	4
Shield			
Vcc	B-4	Brown	12
GND	A-4	Black	13
A	B-5	Red	7
A	A-5	Black	6
B	B-6	Orange	9
B	A-6	Black	8
		—	3

Circuit	Connector B terminal no.	Cable color	Connector D terminal no.
Lock (+)	B-1	Red	4
Lock (-)	A-1	Black	5
Sensor (+) Note)	B-3	Brown	1
Sensor (-) Note)	A-3	Blue	2

Note) This is not used for the LEY series.

[Actuator cable for servo motor (24 VDC)]

LE-CA-1

Cable length (L)

1	1.5 m
3	3 m
5	5 m
8	8 m*
A	10 m*
B	15 m*
C	20 m*

* Produced upon receipt of order

LE-CA-□

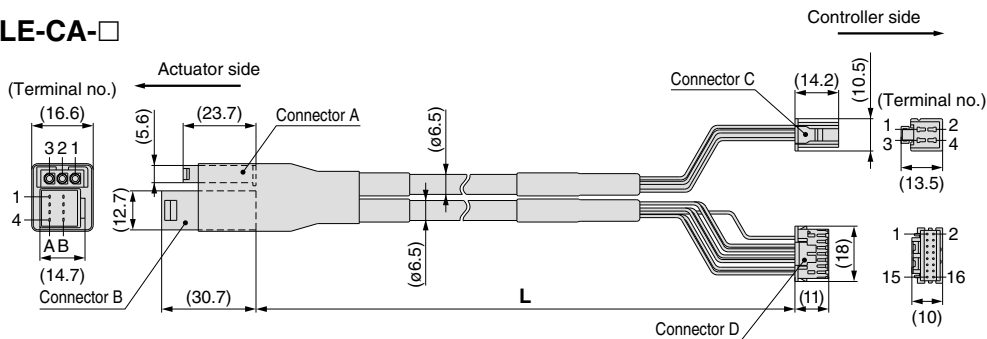

Circuit	Connector A terminal no.	Cable color	Connector C terminal no.
U	1	Red	1
V	2	White	2
W	3	Black	3

Circuit	Connector B terminal no.	Cable color	Connector D terminal no.
Vcc	B-1	Brown	12
GND	A-1	Black	13
A	B-2	Red	7
A	A-2	Black	6
B	B-3	Orange	9
B	A-3	Black	8
Z	B-4	Yellow	11
Z	A-4	Black	10
		—	3

Shield

Connection of shield material

[Actuator cable with lock and sensor for servo motor (24 VDC)]

LE-CA-1-B

Cable length (L)

1	1.5 m
3	3 m
5	5 m
8	8 m*
A	10 m*
B	15 m*
C	20 m*

* Produced upon receipt of order

With lock and sensor

LE-CA-□-B

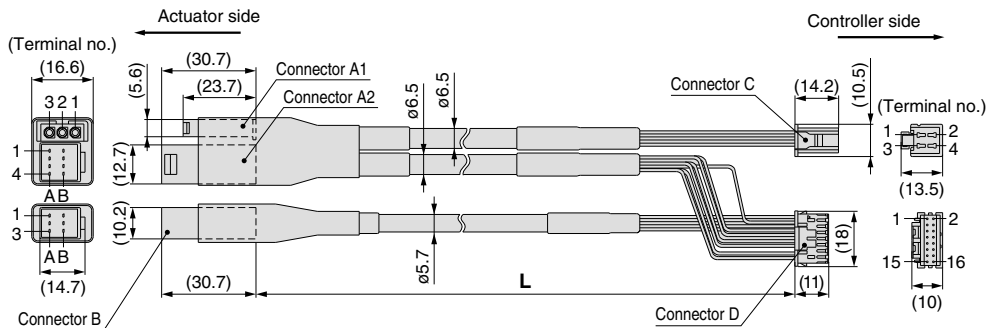

Circuit	Connector A1 terminal no.	Cable color	Connector C terminal no.
U	1	Red	1
V	2	White	2
W	3	Black	3

Circuit	Connector A2 terminal no.	Cable color	Connector D terminal no.
Vcc	B-1	Brown	12
GND	A-1	Black	13
A	B-2	Red	7
A	A-2	Black	6
B	B-3	Orange	9
B	A-3	Black	8
Z	B-4	Yellow	11
Z	A-4	Black	10
		—	3

Circuit	Connector B terminal no.	Cable color	Terminal no.
Brake (+)	B-1	Red	4
Brake (-)	A-1	Black	5
Sensor (+) ^{Note}	B-3	Brown	1
Sensor (-) ^{Note}	A-3	Black	2

Shield

Connection of shield material

Note) This is not used for the LEY series.

Series LECP6

Series LECA6

Options

[I/O cable]

LEC-CN5-1

Cable length (L)

1	1.5 m
3	3 m
5	5 m

* Conductor size: AWG28

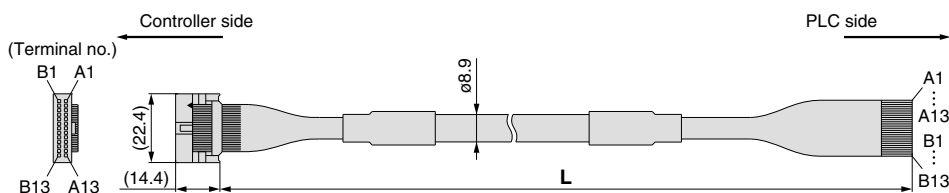

Connector pin No.	Cable color	Dot mark	Dot color
A1	Light brown	■	Black
A2	Light brown	■	Red
A3	Yellow	■	Black
A4	Yellow	■	Red
A5	Light green	■	Black
A6	Light green	■	Red
A7	Gray	■	Black
A8	Gray	■	Red
A9	White	■	Black
A10	White	■	Red
A11	Light brown	■ ■	Black
A12	Light brown	■ ■	Red
A13	Yellow	■ ■	Black

Connector pin No.	Cable color	Dot mark	Dot color
B1	Yellow	■ ■	Red
B2	Light green	■ ■	Black
B3	Light green	■ ■	Red
B4	Gray	■ ■	Black
B5	Gray	■ ■	Red
B6	White	■ ■	Black
B7	White	■ ■	Red
B8	Light brown	■ ■ ■	Black
B9	Light brown	■ ■ ■	Red
B10	Yellow	■ ■ ■	Black
B11	Yellow	■ ■ ■	Red
B12	Light green	■ ■ ■	Black
B13	Light green	■ ■ ■	Red
—	Shield		

[Noise filter set for Servo motor (24 VDC)]

LEC-NFA

Contents of the set: 2 noise filters (Produced by WURTH ELEKTRONIK: 74271222)

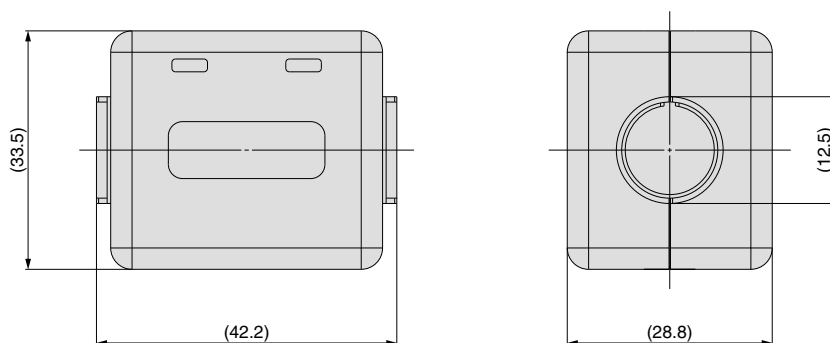

* Refer to the LECA6 series Operation Manual for installation.

Series LEC

Controller Setting Software/LEC-W1

How to Order

LEC-W1

Controller setting software
(Japanese and English are available.)

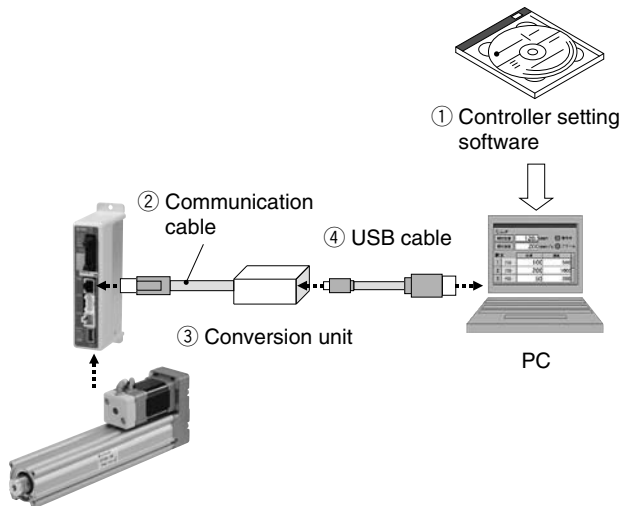

Contents

- ① Controller setting software (CD-ROM)
- ② Communication cable
(Cable between the controller and the conversion unit)
- ③ Conversion unit
- ④ USB cable
(Cable between the PC and the conversion unit)

Hardware Requirements

PC/AT compatible machine installed with Windows XP and equipped with USB1.1 or USB2.0 ports.

* Windows® and Windows XP® are registered trademarks of Microsoft Corporation.

Screen Example

Easy mode screen example

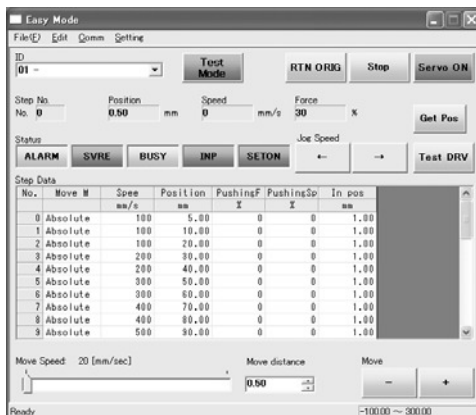

Easy operation and simple setting

- Allowing to set and display actuator step data such as position, speed, force, etc.
- Setting of step data and testing of the drive can be performed on the same page.
- Can be used to jog and move at a constant rate.

Normal mode screen example

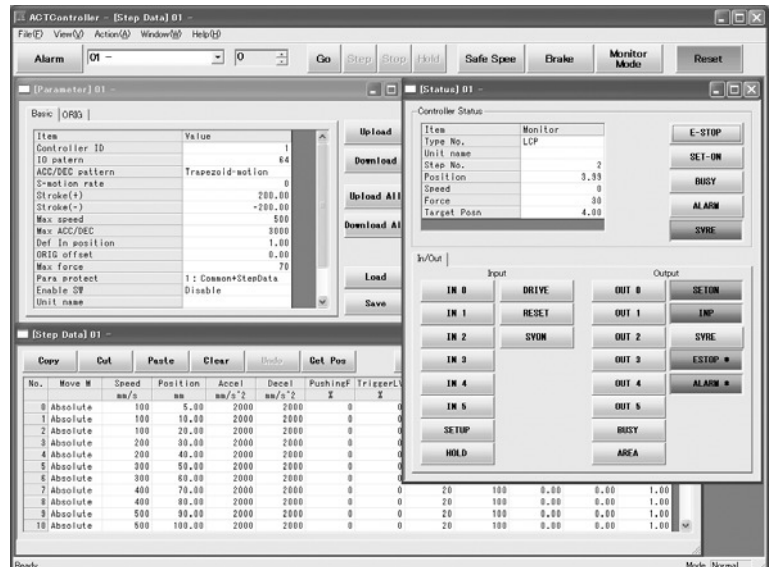

Detail setting

- Step data can be set in detail.
- Signals and terminal status can be monitored.
- Parameters can be set.
- JOG and constant rate movement, return to origin, test operation and testing of compulsory output can be performed.

Teaching Box/LEC-T1



How to Order

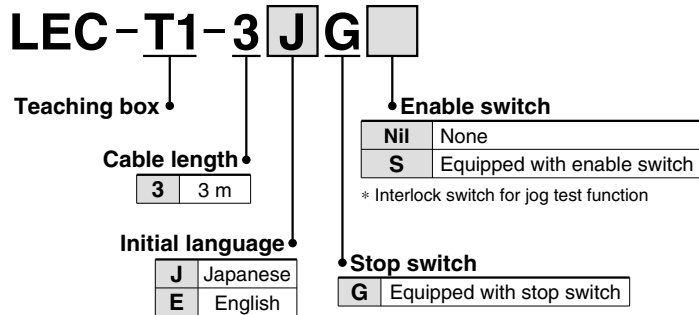

Specifications

Standard functions

- Chinese character display
- Stop switch is provided.

Option

- Enable switch is provided.

Item	Description
Switch	Stop switch, Enable switch (Option)
Cable length	3 m
Enclosure	IP64 (Except connector)
Operating temperature range (°F)	41 to 122 (No condensation)
Operating humidity range (%)	35 to 85
Weight (lb)	0.8 (Except cable)

* The EMC compliance for the teaching box was tested with LECP6 controller and applicable actuator only.

Easy Mode

Function	Description
Step data	• Setting of step data
Jog	• Jog operation • Return to origin
Test	• 1 step operation • Return to origin
Monitor	• Display of axis and step data No. • Display of two items selected from Position, Speed, Force.
Alarm	• Display of active alarm • Alarm reset
TB setting	• Reconnection of axis • Setting of easy/normal mode • Setting of step data and selection of item for monitoring function

Menu Operations Flowchart

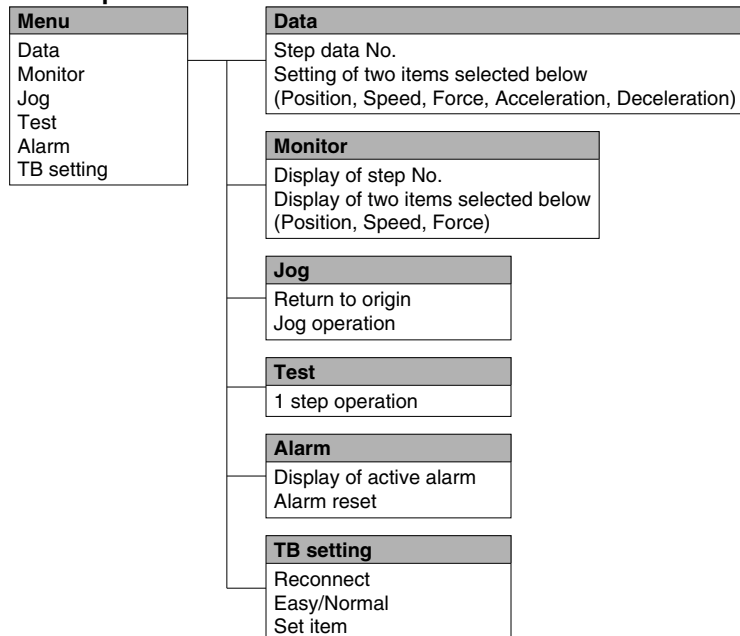

Normal Mode

Function	Description
Step data	• Step data setting
Parameter	• Parameters setting
Test	<ul style="list-style-type: none"> • Jog operation/Constant rate movement • Return to origin • Test drive (Specify a maximum of 5 step data and operate.) • Compulsory output (Compulsory signal output, Compulsory terminal output)
Monitor	<ul style="list-style-type: none"> • Drive monitor • Output signal monitor • Input signal monitor • Output terminal monitor • Input terminal monitor
Alarm	<ul style="list-style-type: none"> • Active alarm display (Alarm reset) • Alarm log record display
File	<ul style="list-style-type: none"> • Data saving Save the step data and parameters of the controller which is being used for communication (it is possible to save four files, with one set of step data and parameters defined as one file). • Load to controller Loads the data which is saved in the teaching box to the controller which is being used for communication. • Delete the saved data.
TB setting	<ul style="list-style-type: none"> • Display setting (Easy/Normal mode) • Language setting (Japanese/English) • Backlight setting • LCD contrast setting • Beep sound setting • Max. connection axis • Distance unit (mm/inch)
Reconnect	• Reconnection of axis

Menu Operations Flowchart

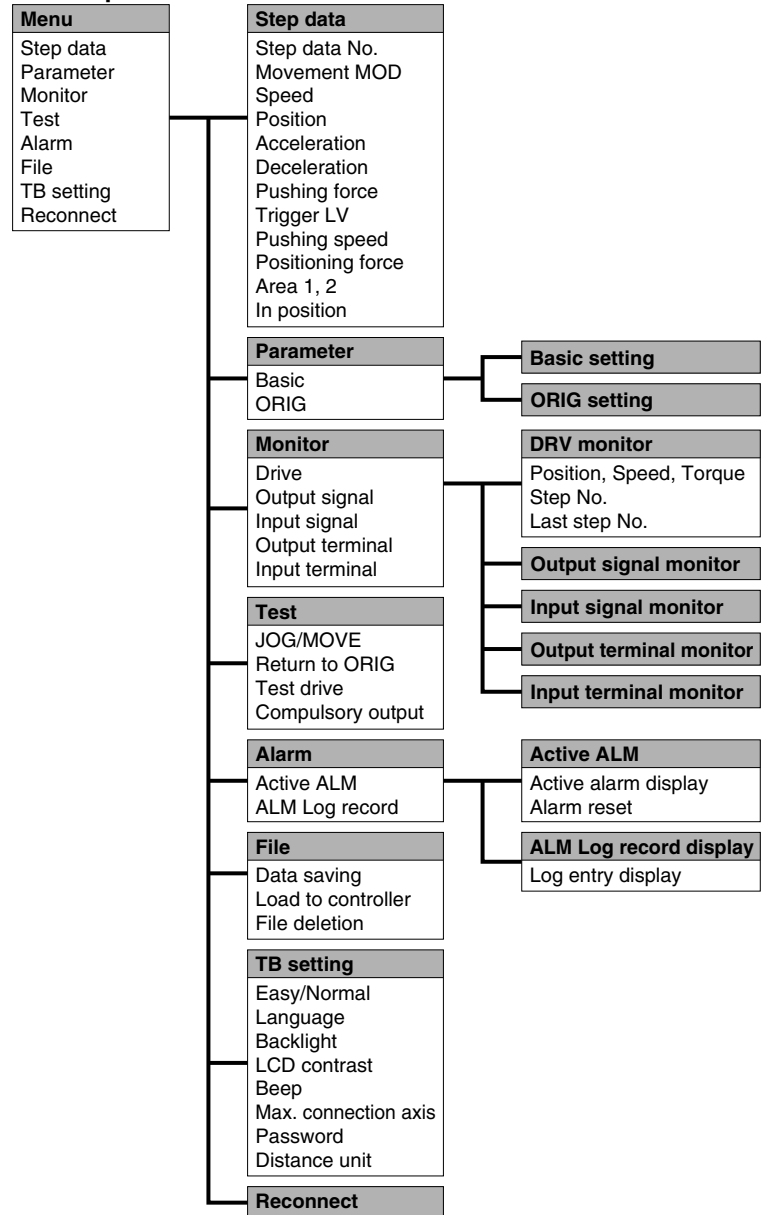

Dimensions

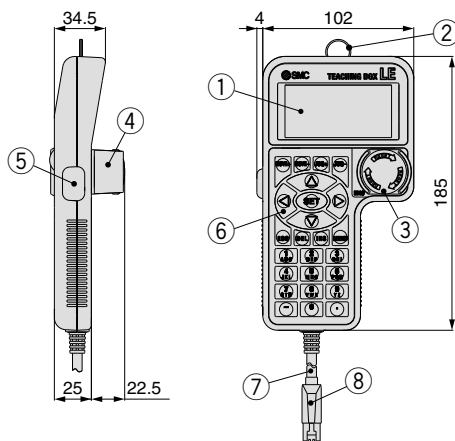

No.	Description	Function
1	LCD	A screen of liquid crystal display (with backlight)
2	Ring	A ring for hanging the teaching box
3	Stop switch	Locks and stops operation when this switch is pressed. The lock is released when it is turned to the right.
4	Stop switch guard	A guard for the stop switch
5	Enable switch (Option)	Prevents unintentional operation (unexpected operation) of the jog test function. Other functions such as data change are not covered.
6	Key switch	Switch for each input
7	Cable	Length: 3 meters
8	Connector	A connector connected to CN4 of the controller



Series LEC Controller and Peripheral Devices/ Specific Product Precautions 1

Be sure to read before handling. Refer to page 32 for Safety Instructions.
Refer to the operation manual for using the products.
Please download it via our website. <http://www.smcworld.com/>

Design/Selection

Warning

- 1. Be sure to apply the specified voltage.**
Otherwise, malfunction and breakage may be caused. If the applied voltage is lower than the specified, it is possible that the load cannot be moved due to an internal voltage drop of the controller. Please check the operating voltage before use.
- 2. Do not operate the product beyond the specifications.**
Otherwise, a fire, malfunction or actuator damage can result. Please check the specifications before use.
- 3. Install an emergency stop circuit outside of the enclosure.**
Please install an emergency stop outside of the enclosure so that it can stop the system operation immediately and intercept the power supply.
- 4. In order to prevent damage due to the breakdown and the malfunction of the controller and its peripheral devices, a backup system should be established previously by giving a multiple-layered structure or a fail-safe design to the equipment, etc.**
- 5. If a danger against the personnel is expected due to an abnormal heat generation, smoking, ignition, etc., of the controller and its peripheral devices, cut off the power supply for the product and the system immediately.**

Handling

Warning

- 1. Do not touch the inside of the controller and its peripheral devices.**
It may cause an electric shock or damage to the controller.
- 2. Do not perform the operation or setting of the product with wet hands.**
It may cause an electric shock.
- 3. Product with damage or the one lacking of any components should not be used.**
It may cause an electric shock, fire, or injury.
- 4. Use only the specified combination between the electric actuator and controller.**
It may cause damage to the actuator or the controller.
- 5. Be careful not to be caught or hit by the workpiece while the actuator is moving.**
It may cause an injury.
- 6. Do not connect the power supply or power on the product before confirming the area to which the workpiece moves is safe.**
The movement of the workpiece may cause an accident.
- 7. Do not touch the product when it is energized and for some time after power has been disconnected, as it is very hot.**
It may lead to a burn due to the high temperature.
- 8. Check the voltage using a tester for more than 5 minutes after power-off in case of installation, wiring and maintenance.**
It may cause an electric shock, fire, or injury.

Handling

Warning

- 9. Static electricity may cause malfunction or break the controller. Do not touch the controller while power is supplied.**
When touching the controller for maintenance, take sufficient measures to eliminate static electricity.
- 10. Do not use the product in an area where dust, powder dust, water, chemicals or oil is in the air.**
It will cause failure or malfunction.
- 11. Do not use the product in an area where a magnetic field is generated.**
It will cause failure or malfunction.
- 12. Do not install the product in the environment of flammable gas, explosive gas and corrosive gas.**
It could lead to fire, explosion and corrosion.
- 13. Radiant heat from strong heat supplies such as a furnace, direct sunlight, etc., should not be applied to the product.**
It will cause failure of the controller or its peripheral devices.
- 14. Do not use the product in an environment subject to a temperature cycle.**
It will cause failure of the controller or its peripheral devices.
- 15. Do not use the product in a place where surges are generated.**
When there are units that generate a large amount of surge around the product (e.g., solenoid type lifters, high frequency induction furnaces, motors, etc.), this may cause deterioration or damage to the product's internal circuit. Avoid supplies of surge generation and crossed lines.
- 16. Do not install the product in an environment under the effect of vibrations and impacts.**
It will cause failure or malfunction.
- 17. When a surge generating load such as a relay or solenoid valve is directly driven, use a product that incorporates a surge absorption element.**

Installation

Warning

- 1. Install the controller and its peripheral devices on a fire-proof material.**
A direct installation on or near a flammable material may cause fire.
- 2. Do not install the product in a place subject to vibrations and impacts.**
It will cause failure or malfunction.
- 3. Do not mount the controller and its peripheral devices together with a large-sized electromagnetic contactor or no-fuse breaker, which generates vibration, on the same panel. Mount them on different panels, or keep the controller and its peripheral devices away from such a vibration supply.**
- 4. Install the controller and its peripheral devices on a flat surface.**
If the mounting surface is distorted or not flat, an unacceptable force may be added to the housing, etc., to cause troubles.



Series LEC

Controller and Peripheral Devices/ Specific Product Precautions 2

Be sure to read before handling. Refer to page 32 for Safety Instructions.
Refer to the operation manual for using the products.
Please download it via our website. <http://www.smcworld.com/>

Power Supply

Caution

- 1. Use a power supply that has low noise between lines and between power and ground.**
In cases where noise is high, an isolation transformer should be used.
- 2. The power supplies should be separated between the controller power and the I/O signal power and both of them do not use the power supply of “inrush current prevention type”.**
If the power supply is “inrush current prevention type”, a voltage drop may be caused during the acceleration of the actuator.
- 3. To prevent surges from lightning, an appropriate measure should be taken. Ground the surge absorber for lightning separately from the grounding of the controller and its peripheral devices.**

Grounding

Warning

- 1. Be sure to carry out grounding in order to ensure the noise tolerance.**
- 2. Dedicated grounding should be used.**
Grounding should be to a D-class ground. (Ground resistance of 100 Ω or less)
- 3. Grounding should be performed near the controller and its peripheral devices to shorten the grounding distance.**
- 4. In the unlikely event that malfunction is caused by ground, please disconnect the unit from ground.**

Maintenance

Warning

- 1. Perform a maintenance check periodically.**
Confirm wiring and screws are not loose.
Loose screws or wires may cause unintentional malfunction.
- 2. Conduct an appropriate functional inspection after completing the maintenance.**
At times where the equipment or machinery does not operate properly, conduct an emergency stop of the system. Otherwise, an unexpected malfunction may occur and it will become impossible to secure the safety. Conduct a test of the emergency stop in order to confirm the safety of the equipment.
- 3. Do not disassemble, modify or repair the controller and its peripheral devices.**
- 4. Do not put anything conductive or flammable inside of the controller.**
It may cause a fire.
- 5. Do not conduct an insulation resistance test and withstand voltage test on this product.**
- 6. Ensure sufficient space for maintenance activities.**
Design the system that allows required space for maintenance.

Safety Instructions

These safety instructions are intended to prevent hazardous situations and/or equipment damage. These instructions indicate the level of potential hazard with the labels of “**Caution**,” “**Warning**” or “**Danger**.” They are all important notes for safety and must be followed in addition to International Standards (ISO/IEC), American National Standards Institute (ANSI)*1) and other safety regulations.

Caution:

Caution indicates a hazard with a low level of risk which, if not avoided, could result in minor or moderate injury.

Warning:

Warning indicates a hazard with a medium level of risk which, if not avoided, could result in death or serious injury.

Danger :

Danger indicates a hazard with a high level of risk which, if not avoided, will result in death or serious injury.

*1) ISO 4414: Pneumatic fluid power – General rules relating to systems.
ISO 4413: Hydraulic fluid power – General rules relating to systems.
IEC 60204-1: Safety of machinery – Electrical equipment of machines. (Part 1: General requirements)
ISO 10218-1: Manipulating industrial robots - Safety.
ANSI / (NFPA) T2.25.1 R2: Pneumatic fluid power - Systems standard for industrial machinery.
NFPA (Fluid) T2.24.1 R1: Hydraulic fluid power - Systems standard for stationary industrial machinery.
NFPA 79: Electrical Standard for Industrial Machinery.
ANSI / RIA / ISO 10218 -1: Robots for Industrial Environment - Safety Requirements - Part 1 - Robot. etc.

Warning

1. The compatibility of the product is the responsibility of the person who designs the equipment or decides its specifications.

Since the product specified here is used under various operating conditions, its compatibility with specific equipment must be decided by the person who designs the equipment or decides its specifications based on necessary analysis and test results. The expected performance and safety assurance of the equipment will be the responsibility of the person who has determined its compatibility with the product. This person should also continuously review all specifications of the product referring to its latest catalog information, with a view to giving due consideration to any possibility of equipment failure when configuring the equipment.

2. Only personnel with appropriate training should operate machinery and equipment.

The product specified here may become unsafe if handled incorrectly. The assembly, operation and maintenance of machines or equipment including our products must be performed by an operator who is appropriately trained and experienced.

3. Do not service or attempt to remove product and machinery/equipment until safety is confirmed.

1. The inspection and maintenance of machinery/equipment should only be performed after measures to prevent falling or runaway of the driven objects have been confirmed.
2. When the product is to be removed, confirm that the safety measures as mentioned above are implemented and the power from any appropriate source is cut, and read and understand the specific product precautions of all relevant products carefully.
3. Before machinery/equipment is restarted, take measures to prevent unexpected operation and malfunction.

4. Contact SMC beforehand and take special consideration of safety measures if the product is to be used in any of the following conditions.

1. Conditions and environments outside of the given specifications, or use outdoors or in a place exposed to direct sunlight.
2. Installation on equipment in conjunction with atomic energy, railways, air navigation, space, shipping, vehicles, military, medical treatment, combustion and recreation, or equipment in contact with food and beverages, emergency stop circuits, clutch and brake circuits in press applications, safety equipment or other applications unsuitable for the standard specifications described in the product catalog.
3. An application which could have negative effects on people, property, or animals requiring special safety analysis.
4. Use in an interlock circuit, which requires the provision of double interlock for possible failure by using a mechanical protective function, and periodical checks to confirm proper operation.

Caution

1. The product is provided for use in manufacturing industries.

The product herein described is basically provided for peaceful use in manufacturing industries.

If considering using the product in other industries, consult SMC beforehand and exchange specifications or a contract if necessary.

If anything is unclear, contact your nearest sales branch.

Limited warranty and Disclaimer/ Compliance Requirements

The product used is subject to the following “Limited warranty and Disclaimer” and “Compliance Requirements”. Read and accept them before using the product.

Limited warranty and Disclaimer

1. The warranty period of the product is 1 year in service or 1.5 years after the product is delivered.*2)
Also, the product may have specified durability, running distance or replacement parts. Please consult your nearest sales branch.
2. For any failure or damage reported within the warranty period which is clearly our responsibility, a replacement product or necessary parts will be provided.
This limited warranty applies only to our product independently, and not to any other damage incurred due to the failure of the product.
3. Prior to using SMC products, please read and understand the warranty terms and disclaimers noted in the specified catalog for the particular products.

*2) Vacuum pads are excluded from this 1 year warranty.

A vacuum pad is a consumable part, so it is warranted for a year after it is delivered. Also, even within the warranty period, the wear of a product due to the use of the vacuum pad or failure due to the deterioration of rubber material are not covered by the limited warranty.

Compliance Requirements

1. The use of SMC products with production equipment for the manufacture of weapons of mass destruction (WMD) or any other weapon is strictly prohibited.
2. The exports of SMC products or technology from one country to another are governed by the relevant security laws and regulations of the countries involved in the transaction. Prior to the shipment of a SMC product to another country, assure that all local rules governing that export are known and followed.

Safety Instructions

Be sure to read “Handling Precautions for SMC Products” (M-E03-3) before using.