



Single Axis Electric Actuator

Series **LJ1H**

High Rigidity Direct Acting Guide

Series	Motor type	Guide type	Mounting orientation	Model	Lead screw lead mm		Page
					Ground ball screw	Rolled ball screw	
LJ1H	Standard motor	High rigidity direct acting guide	Horizontal	LJ1H10	12	12	Page 2 to
				LJ1H20	10 20	10 20	Page 6 to
				LJ1H30	25	25	Page 14 to
			Vertical	LJ1H10	8 12	8 12	Page 18 to
				LJ1H20	5 10	5 10	Page 26 to
				LJ1H30	10	10	Page 34 to

- Options ————— Page 38
- Construction ————— Page 39 to
- Mounting ————— Page 42 to
- Deflection Data ————— Page 45

Part Number Designations

LJ1 H 10 S2 N H - 100 K - F R 5 A1 -

Series

10
20
30

Motor type

S2	AC servo motor (Incremental encoder) 100 W
S3	AC servo motor (Incremental encoder) 200 W
S6	AC servo motor (Absolute encoder) 100 W
S7	AC servo motor (Absolute encoder) 200 W

Lead screw type

P	Ground
N	Rolled

Lead screw lead

F	5 mm
H	8 mm
A	10 mm
B	12 mm
C	20 mm
D	25 mm

Lock

Nil	None
K	With brake

Stroke (mm)

100

Cable entry direction

F	Axial
R	Right
L	Left
T	Top
B	Bottom

Auto switch

Nil	Without switch
1	NPN, A contact 1pc.
2	B contact 2pcs.
3	NPN, A contact 1pc., B contact 2pcs.
4	PNP, A contact 1pc.
5	PNP, B contact 2pcs.
6	PNP, A contact 1pc., B contact 2pcs.

IO connector

Nil	None
H	With IO connector

Driver type

Nil	Driver
A1	Pulse input type (Incremental encoder) 100 V
A2	Pulse input type (Incremental encoder) 200 V
B1	Pulse input type (Absolute encoder) 100 V
B2	Pulse input type (Absolute encoder) 200 V

Cable length

2	2 m
5	5 m
A	10 m

Cable type

S	Standard cable
R	Robotic cable (flexible cable)

The tables above show the definition for each symbol only and cannot be used for actual model selection.

Standard Motor Horizontal Mount Series **LJ1H10**

Motor Output
100 W

High Rigidity
Direct Acting
Guide

Ground Ball Screw
∅12 mm/12 mm lead

How to Order

LJ1H10 S2 PB - 300 - F R 2 A1

Motor type

S2	AC servo motor (Incremental encoder) 100 W
S6	AC servo motor (Absolute encoder) 100 W

Stroke (mm)
Refer to the standard stroke.

Cable entry direction

F	Axial
R	Right
L	Left
T	Top
B	Bottom

Cable type

S	Standard cable
R	Robotic cable (flexible cable)

Cable length

2	2 m
5	5 m
A	10 m

IO connector

Nil	None
H	With IO connector

Auto switch

Nil	Without switch
1	NPN, A contact 1pc.
2	NPN, B contact 2pcs.
3	NPN, A contact 1pc., B contact 2pcs.
4	PNP, A contact 1pc.
5	PNP, B contact 2pcs.
6	PNP, A contact 1pc., B contact 2pcs.

Driver type

Nil	Without driver
A1	Pulse input type (Incremental encoder) 100 V
A2	Pulse input type (Incremental encoder) 200 V
B1	Pulse input type (Absolute encoder) 100 V
B2	Pulse input type (Absolute encoder) 200 V

Specifications

Standard stroke (mm)		100	200	300	400	500
Performance	Body weight (kg)	5.2	6.0	6.8	7.5	8.3
	Operating temperature range (°C)	5 to 40 (No condensation)				
	Work load (kg)	10				
	Maximum speed (mm/s)	600				
	Positioning repeatability (mm)	±0.02				
Main parts	Motor	AC servo motor (100 W)				
	Encoder	Incremental system/Absolute type				
	Lead screw	Ground ball screw ∅12 mm, 12 mm lead				
	Guide	High rigidity direct acting guide				
	Motor/Screw connection	With coupling				
Driver	Model	LECS□□□□ (Refer to page 97 for details.)				

Allowable Moment (N·m)

Allowable static moment

Pitching	10.2
Rolling	12.8
Yawing	10.2

m : Transfer load (kg)
a : Work piece acceleration (mm/s²)
Me : Dynamic moment
L : Overhang to work piece center of gravity (mm)

Allowable dynamic moment

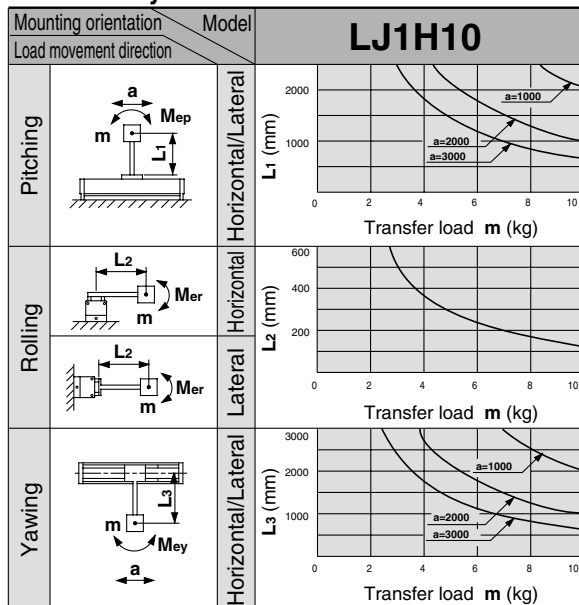

Refer to page 45 for deflection data.

Investigation of the regeneration option

Depending on the conditions (speed, addition-subtraction speed, down time, load, etc.), the regeneration option may be required. The results of consideration in each case of maximum load or half load for the product specification are below. Please consult SMC when considering the necessity of the regeneration option.

Maximum load

Driver type	Regeneration option model
A1	Not required.
A2	Not required.
B1	Not required.
B2	Not required.

Half load

Driver type	Regeneration option model
A1	Not required.
A2	Not required.
B1	Not required.
B2	Not required.

Series LJ1H10

Dimensions/LJ1H10□PB

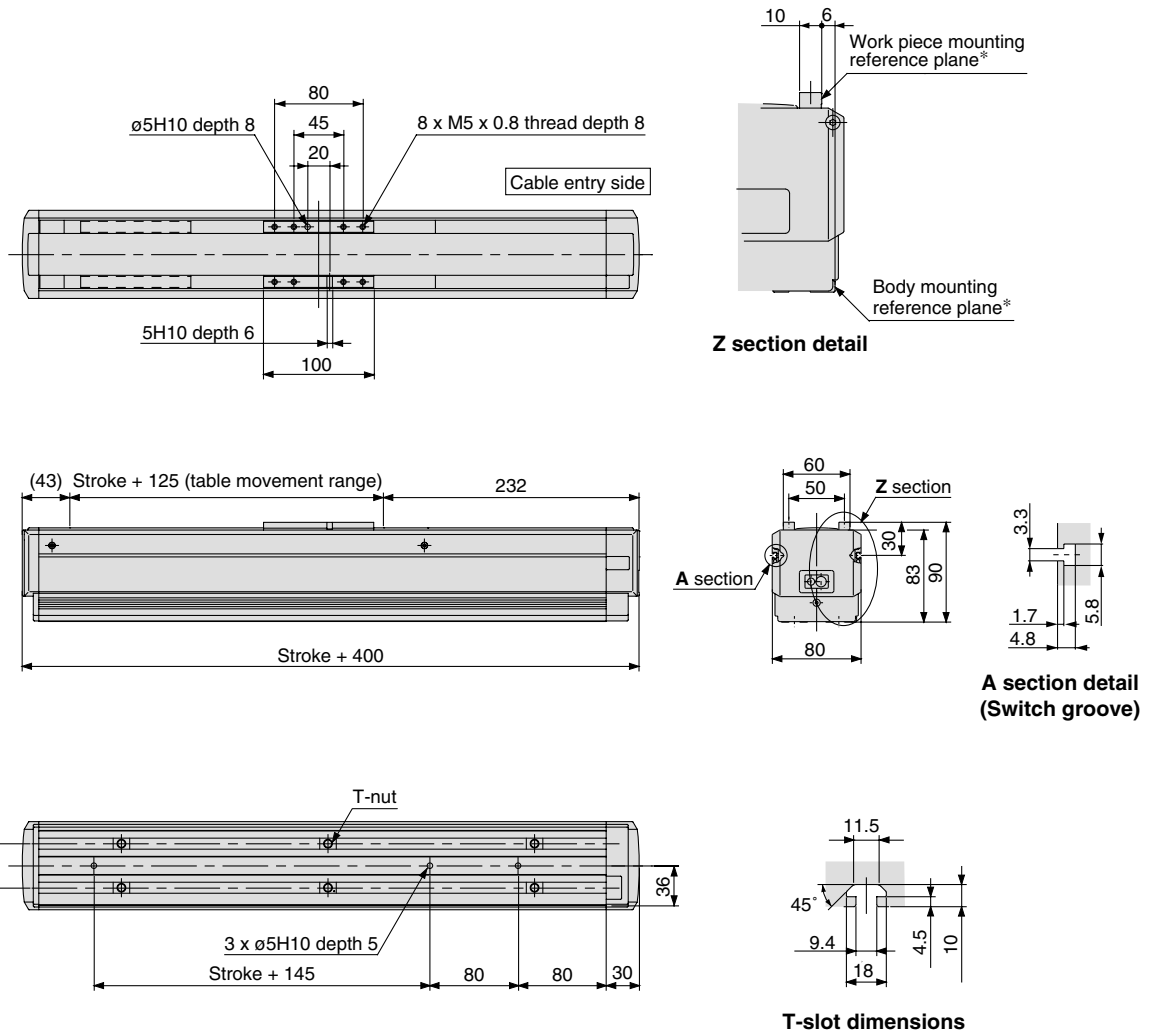

* The body mounting reference plane and work piece mounting reference plane should be used as standards when mounting onto equipment. Refer to pages starting with 42 for mounting.

Positioning Time Guide

		Positioning time (sec.)				
		1	10	100	250	500
Speed (mm/s)	10	0.4	1.3	10.3	25.3	50.3
	100	0.4	0.5	1.4	2.9	5.4
	300	0.4	0.5	0.8	1.3	2.1
	600	0.4	0.5	0.7	1.0	1.4

* Values will vary slightly depending on the operating conditions.

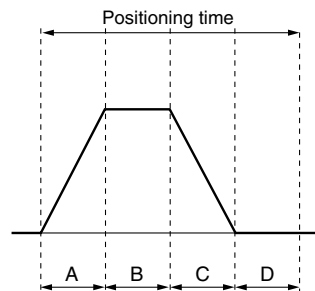

A: Acceleration time
 B: Constant velocity time
 C: Deceleration time
 D: Resting time (0.3 sec.)
 Maximum acceleration: 3000 mm/s²

Standard Motor Horizontal Mount Series **LJ1H10**

Motor Output
100 W

High Rigidity
Direct Acting
Guide

Rolled Ball Screw
∅12 mm/12 mm lead

How to Order

LJ1H10 S2 NB - 300 - F R 2 A1

Motor type

S2	AC servo motor (Incremental encoder) 100 W
S6	AC servo motor (Absolute encoder) 100 W

Stroke (mm)
Refer to the standard stroke.

Cable entry direction

F	Axial
R	Right
L	Left
T	Top
B	Bottom

Cable type

S	Standard cable
R	Robotic cable (flexible cable)

Cable length

2	2 m
5	5 m
A	10 m

IO connector

Nil	None
H	With IO connector

Auto switch

Nil	Without switch
1	NPN, A contact 1pc.
2	B contact 2pcs.
3	NPN, A contact 1pc., B contact 2pcs.
4	PNP, A contact 1pc.
5	PNP, B contact 2pcs.
6	PNP, A contact 1pc., B contact 2pcs.

Driver type

Nil	Without driver
A1	Pulse input type (Incremental encoder) 100 V
A2	Pulse input type (Incremental encoder) 200 V
B1	Pulse input type (Absolute encoder) 100 V
B2	Pulse input type (Absolute encoder) 200 V

Cable entry direction

Specifications

Standard stroke (mm)		100	200	300	400	500
Performance	Body weight (kg)	5.2	6.0	6.8	7.5	8.3
	Operating temperature range (°C)	5 to 40 (No condensation)				
	Work load (kg)	10				
	Maximum speed (mm/s)	600				
	Positioning repeatability (mm)	±0.05				
Main parts	Motor	AC servo motor (100 W)				
	Encoder	Incremental system/Absolute type				
	Lead screw	Ground ball screw ∅12 mm, 12 mm lead				
	Guide	High rigidity direct acting guide				
	Motor/Screw connection	With coupling				
Driver	Model	LECS□□□□ (Refer to page 97 for details.)				

Allowable Moment (N·m)

Allowable static moment

Pitching	10.2
Rolling	12.8
Yawing	10.2

m : Transfer load (kg)
a : Work piece acceleration (mm/s²)
Me : Dynamic moment
L : Overhang to work piece center of gravity (mm)

Allowable dynamic moment

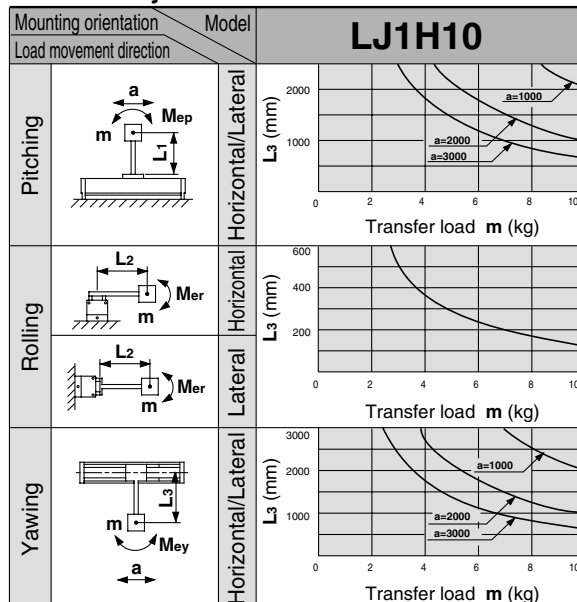

Refer to page 45 for deflection data.

Investigation of the regeneration option

Depending on the conditions (speed, addition-subtraction speed, down time, load, etc.), the regeneration option may be required. The results of consideration in each case of maximum load or half load for the product specification are below. Please consult SMC when considering the necessity of the regeneration option.

Maximum load

Driver type	Regeneration option model
A1	Not required.
A2	Not required.
B1	Not required.
B2	Not required.

Half load

Driver type	Regeneration option model
A1	Not required.
A2	Not required.
B1	Not required.
B2	Not required.

Dimensions/LJ1H10□NB

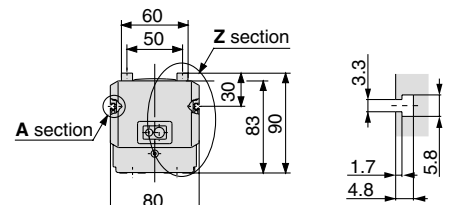
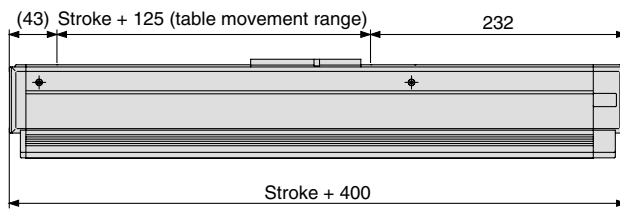
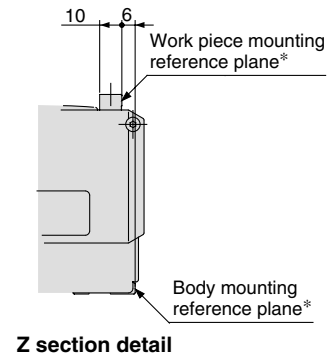
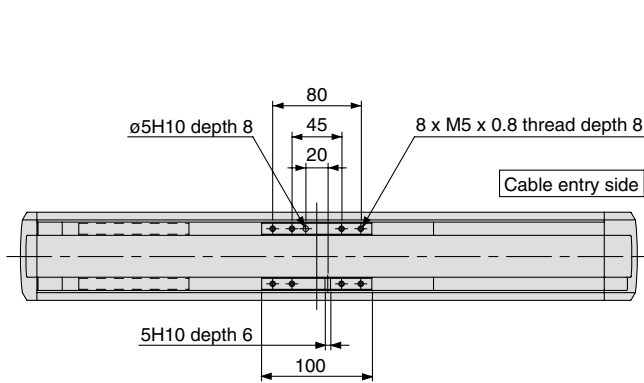

A section detail (Switch groove)

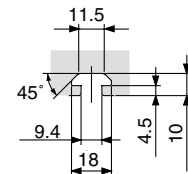
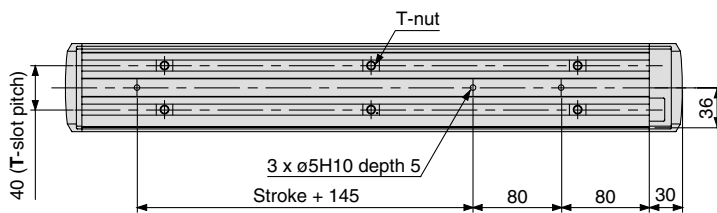

T-slot dimensions

* The body mounting reference plane and work piece mounting reference plane should be used as standards when mounting onto equipment. Refer to pages starting with 42 for mounting.

Positioning Time Guide

		Positioning time (sec.)				
		1	10	100	250	500
Speed (mm/s)	10	0.4	1.3	10.3	25.3	50.3
	100	0.4	0.5	1.4	2.9	5.4
	300	0.4	0.5	0.8	1.3	2.1
	600	0.4	0.5	0.7	1.0	1.4

* Values will vary slightly depending on the operating conditions.

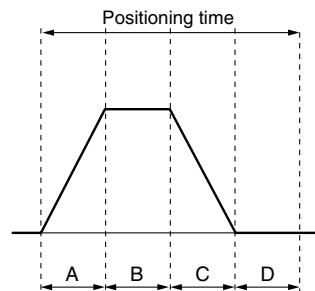

A: Acceleration time
 B: Constant velocity time
 C: Deceleration time
 D: Resting time (0.3 sec.)
 Maximum acceleration: 3000 mm/s²

Standard Motor Horizontal Mount Series LJ1H20

Motor Output
100 W

High Rigidity
Direct Acting
Guide

Ground Ball Screw
∅15 mm/10 mm lead

How to Order

LJ1H20 S2 PA - 300 - F R 2 A1

Motor type

S2	AC servo motor (Incremental encoder) 100 W
S6	AC servo motor (Absolute encoder) 100 W

Stroke (mm)
Refer to the standard stroke.

Cable entry direction

F	Axial
R	Right
L	Left
T	Top
B	Bottom

Cable type

S	Standard cable
R	Robotic cable (flexible cable)

Cable length

2	2 m
5	5 m
A	10 m

IO connector

Nil	None
H	With IO connector

Auto switch

Nil	Without switch
1	NPN, A contact 1pc.
2	NPN, B contact 2pcs.
3	NPN, A contact 1pc., B contact 2pcs.
4	PNP, A contact 1pc.
5	PNP, B contact 2pcs.
6	PNP, A contact 1pc., B contact 2pcs.

Driver type

Nil	Without driver
A1	Pulse input type (Incremental encoder) 100 V
A2	Pulse input type (Incremental encoder) 200 V
B1	Pulse input type (Absolute encoder) 100 V
B2	Pulse input type (Absolute encoder) 200 V

Specifications

Standard stroke (mm)		100	200	300	400	500	600
Performance	Body weight (kg)	7.7	8.9	10.1	11.2	12.6	13.7
	Operating temperature range (°C)	5 to 40 (No condensation)					
	Work load (kg)	30					
	Maximum speed (mm/s)	500					
	Positioning repeatability (mm)	±0.02					
Main parts	Motor	AC servo motor (100W)					
	Encoder	Incremental system/Absolute type					
	Lead screw	Ground ball screw ∅15 mm, 10 mm lead					
	Guide	High rigidity direct acting guide					
	Motor/Screw connection	With coupling					
Driver	Model	LECS□□-□ (Refer to page 97 for details.)					

Allowable Moment (N·m)

Allowable static moment

Pitching	71
Rolling	83
Yawing	75

m : Transfer load (kg)
a : Work piece acceleration (mm/s²)
Me : Dynamic moment
L : Overhang to work piece center of gravity (mm)

Allowable dynamic moment

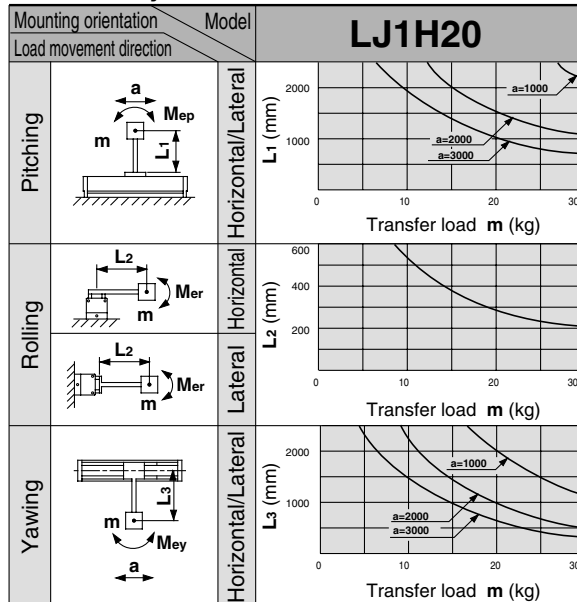

Refer to page 45 for deflection data.

Investigation of the regeneration option

Depending on the conditions (speed, addition-subtraction speed, down time, load, etc.), the regeneration option may be required. The results of consideration in each case of maximum load or half load for the product specification are below. Please consult SMC when considering the necessity of the regeneration option.

Maximum load

Driver type	Regeneration option model
A1	Not required.
A2	Not required.
B1	Not required.
B2	Not required.

Half load

Driver type	Regeneration option model
A1	Not required.
A2	Not required.
B1	Not required.
B2	Not required.

Dimensions/LJ1H20□PA

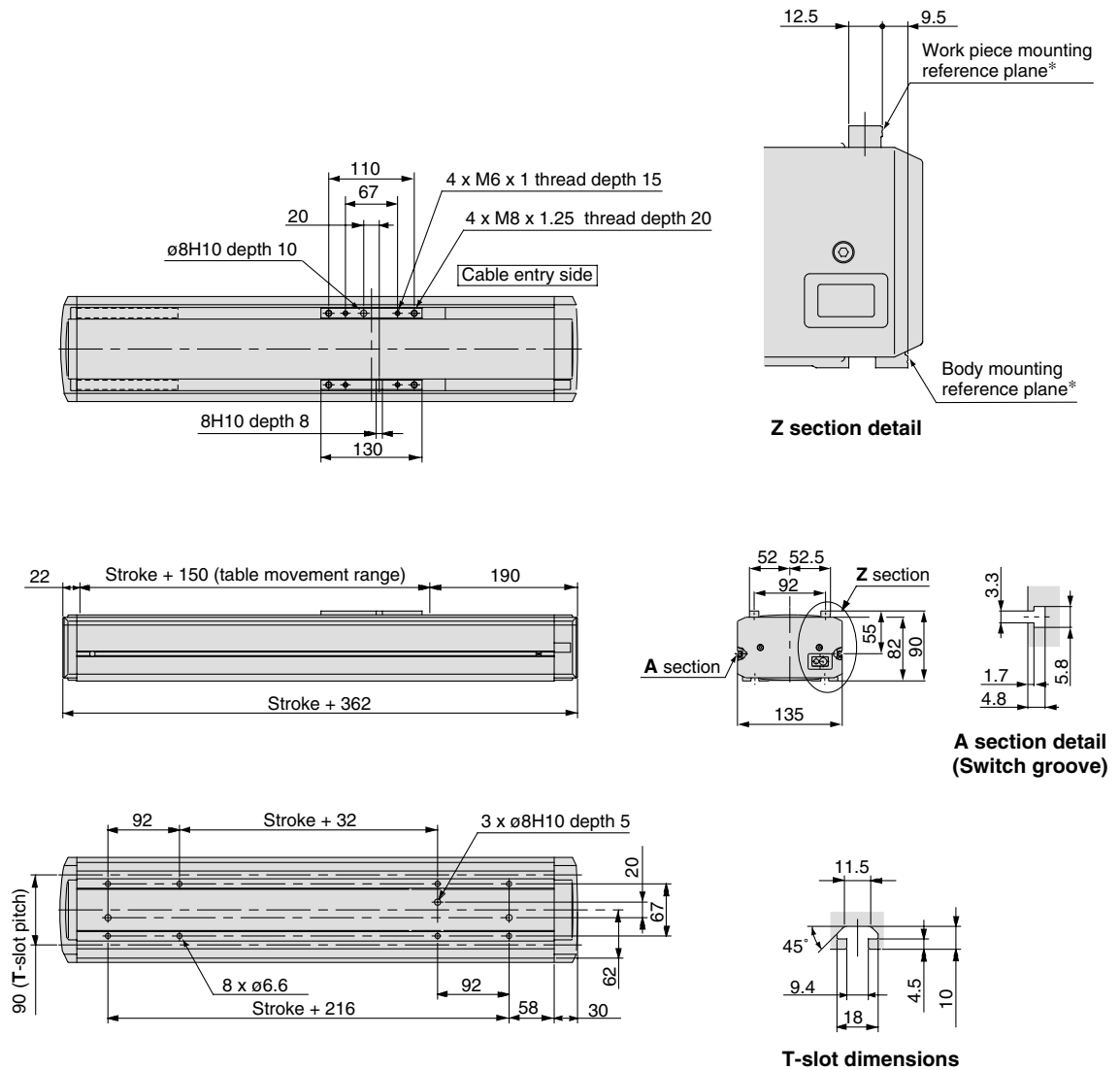

* The body mounting reference plane and work piece mounting reference plane should be used as standards when mounting onto equipment. Refer to pages starting with 42 for mounting.

Positioning Time Guide

		Positioning time (sec.)				
		1	10	100	300	600
Speed (mm/s)	10	0.5	1.4	10.4	30.4	60.4
	100	0.5	0.6	1.5	3.5	6.5
	250	0.5	0.6	0.9	1.7	2.9
	500	0.5	0.6	0.8	1.2	1.8

* Values will vary slightly depending on the operating conditions.

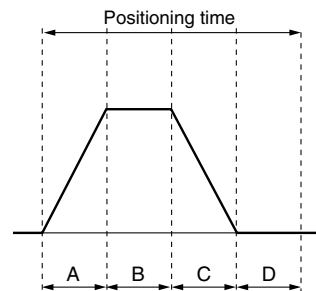

A: Acceleration time
 B: Constant velocity time
 C: Deceleration time
 D: Resting time (0.4 sec.)
 Maximum acceleration: 3000 mm/s²

Standard Motor Horizontal Mount Series **LJ1H20**

Motor Output
100 W

High Rigidity
Direct Acting
Guide

Ground Ball Screw
∅15 mm/20 mm lead

How to Order

LJ1H20 S2 PC - 500 - F R 2 A1

Motor type

S2	AC servo motor (Incremental encoder) 100 W
S6	AC servo motor (Absolute encoder) 100 W

Stroke (mm)
Refer to the standard stroke.

Cable entry direction

F	Axial
R	Right
L	Left
T	Top
B	Bottom

Cable type

S	Standard cable
R	Robotic cable (flexible cable)

Cable length

2	2 m
5	5 m
A	10 m

IO connector

Nil	None
H	With IO connector

Auto switch

Nil	Without switch
1	NPN, A contact 1pc.
2	NPN, B contact 2pcs.
3	NPN, A contact 1pc., B contact 2pcs.
4	PNP, A contact 1pc.
5	PNP, B contact 2pcs.
6	PNP, A contact 1pc., B contact 2pcs.

Driver type

Nil	Without driver
A1	Pulse input type (Incremental encoder) 100 V
A2	Pulse input type (Incremental encoder) 200 V
B1	Pulse input type (Absolute encoder) 100 V
B2	Pulse input type (Absolute encoder) 200 V

Specifications

Standard stroke (mm)		500	600	700	800	900	1000
Performance	Body weight (kg)	12.6	13.7	14.5	15.3	17.2	18.6
	Operating temperature range (°C)	5 to 40 (No condensation)					
	Work load (kg)	30					
	Maximum speed (mm/s) ^{Note)}	1000	1000	930	740	600	500
	Positioning repeatability (mm)	±0.02					
Main parts	Motor	AC servo motor (100 W)					
	Encoder	Incremental system/Absolute type					
	Lead screw	Ground ball screw ∅15 mm, 20 mm lead					
	Guide	High rigidity direct acting guide					
	Motor/Screw connection	With coupling					
Driver	Model	LECS□□-□ (Refer to page 97 for details.)					

Note) The speed is limited by the transfer load. Refer to the maximum speeds for each transfer load on the next page.

Allowable Moment (N·m)

Allowable static moment

Pitching	71
Rolling	83
Yawing	75

m : Transfer load (kg)
a : Work piece acceleration (mm/s²)
Me : Dynamic moment
L : Overhang to work piece center of gravity (mm)

Allowable dynamic moment

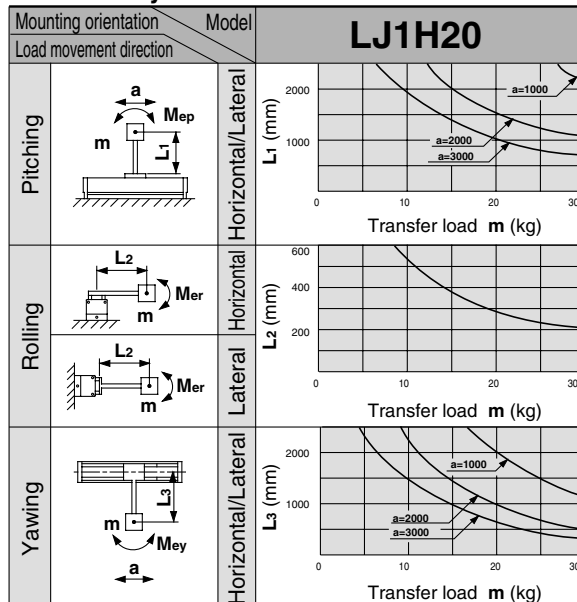

Refer to page 45 for deflection data.

Investigation of the regeneration option

Depending on the conditions (speed, addition-subtraction speed, down time, load, etc.), the regeneration option may be required. The results of consideration in each case of maximum load or half load for the product specification are below. Please consult SMC when considering the necessity of the regeneration option.

Maximum load

Driver type	Regeneration option model
A1	LEC-MR-RB-032
A2	Not required.
B1	LEC-MR-RB-032
B2	Not required.

Half load

Driver type	Regeneration option model
A1	Not required.
A2	Not required.
B1	Not required.
B2	Not required.

Series LJ1H20

Dimensions/LJ1H20□PC

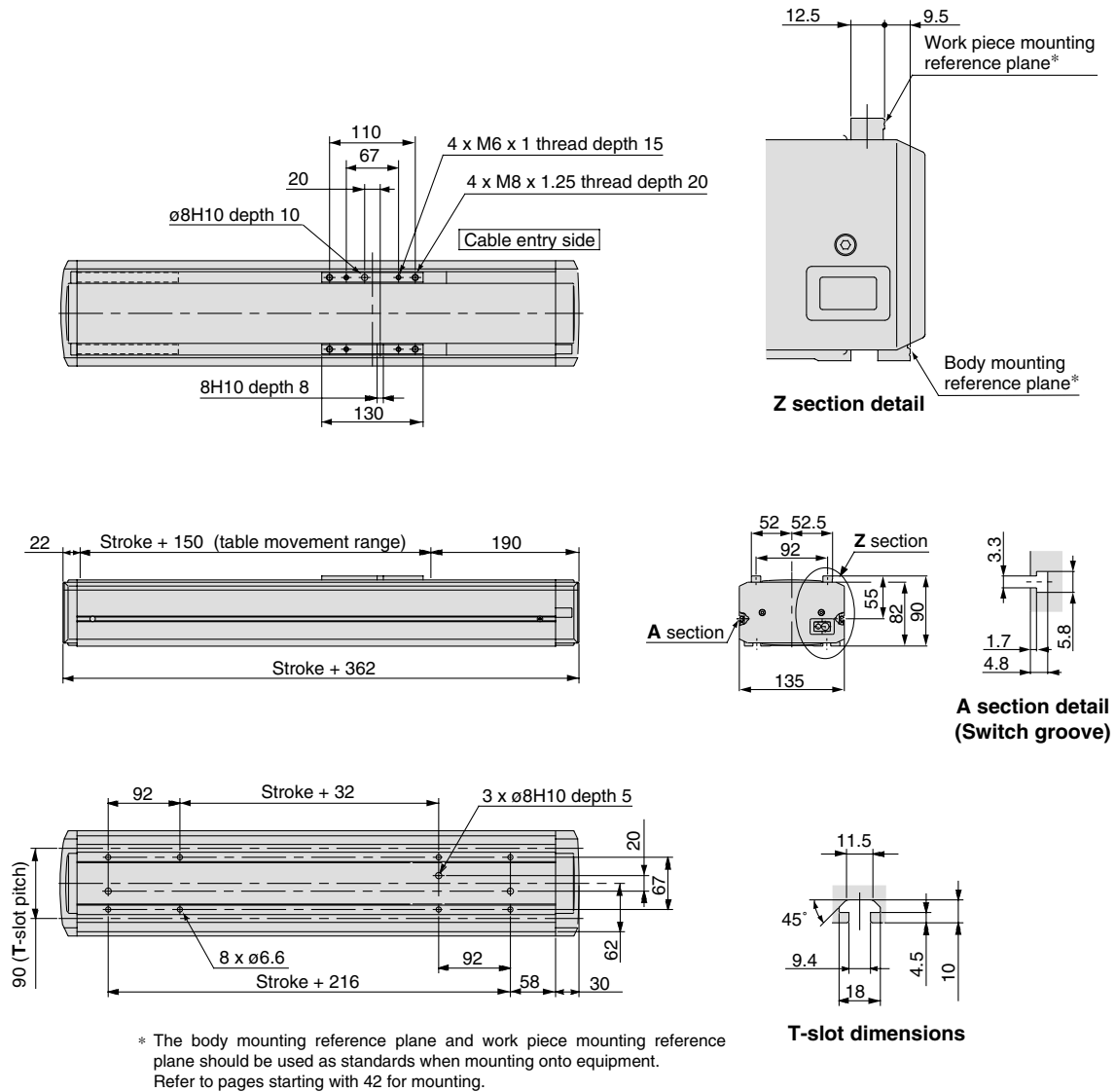

Positioning Time Guide

		Positioning time (sec.)				
Positioning distance (mm)		1	10	100	500	1000
Speed (mm/s)	10	0.6	1.5	10.5	50.5	100.5
	100	0.5	0.6	1.5	5.5	10.5
	500	0.5	0.6	0.9	1.7	2.7
	1000	0.5	0.6	0.9	1.4	1.9

* Values will vary slightly depending on the operating conditions.

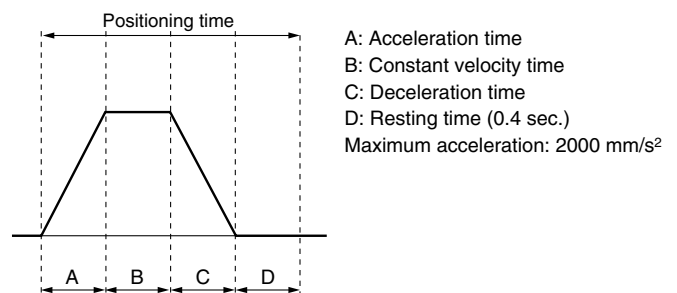

Maximum Speeds for Each Transfer Load

Model	Transfer load (kg)			
	15	20	25	30
LJ1H20□PC-500-□	1000	700	500	500
LJ1H20□PC-600-□	1000	700	500	500
LJ1H20□PC-700-□	930	600	500	500
LJ1H20□PC-800-□	740	600	500	500
LJ1H20□PC-900-□	600	500	500	500
LJ1H20□PC-1000-□	500	500	500	500

Unit (mm/s)

Standard Motor Horizontal Mount Series **LJ1H20**

Motor Output
100 W

High Rigidity
Direct Acting
Guide

Rolled Ball Screw
∅15 mm/10 mm lead

How to Order

LJ1H20 S2 NA - 300 - F R 2 A1

Motor type

S2	AC servo motor (Incremental encoder) 100 W
S6	AC servo motor (Absolute encoder) 100 W

Stroke (mm)
Refer to the standard stroke.

Cable entry direction

F	Axial
R	Right
L	Left
T	Top
B	Bottom

Cable type

S	Standard cable
R	Robotic cable (flexible cable)

Cable length

2	2 m
5	5 m
A	10 m

IO connector

Nil	None
H	With IO connector

Auto switch

Nil	Without switch
1	NPN, A contact 1pc.
2	NPN, B contact 2pcs.
3	NPN, A contact 1pc., B contact 2pcs.
4	PNP, A contact 1pc.
5	PNP, B contact 2pcs.
6	PNP, A contact 1pc., B contact 2pcs.

Driver type

Nil	Without driver
A1	Pulse input type (Incremental encoder) 100 V
A2	Pulse input type (Incremental encoder) 200 V
B1	Pulse input type (Absolute encoder) 100 V
B2	Pulse input type (Absolute encoder) 200 V

Specifications

Standard stroke (mm)		100	200	300	400	500	600
Performance	Body weight (kg)	7.7	8.9	10.1	11.2	12.6	13.7
	Operating temperature range (°C)	5 to 40 (No condensation)					
	Work load (kg)	30					
	Maximum speed (mm/s)	500					
	Positioning repeatability (mm)	±0.05					
Main parts	Motor	AC servo motor (100 W)					
	Encoder	Incremental system/Absolute type					
	Lead screw	Rolled ball screw ∅15 mm, 10 mm lead					
	Guide	High rigidity direct acting guide					
	Motor/Screw connection	With coupling					
Driver	Model	LECS□□□□ (Refer to page 97 for details.)					

Allowable Moment (N·m)

Allowable static moment

Pitching	71
Rolling	83
Yawing	75

m : Transfer load (kg)
a : Work piece acceleration (mm/s²)
Me : Dynamic moment
L : Overhang to work piece center of gravity (mm)

Allowable dynamic moment

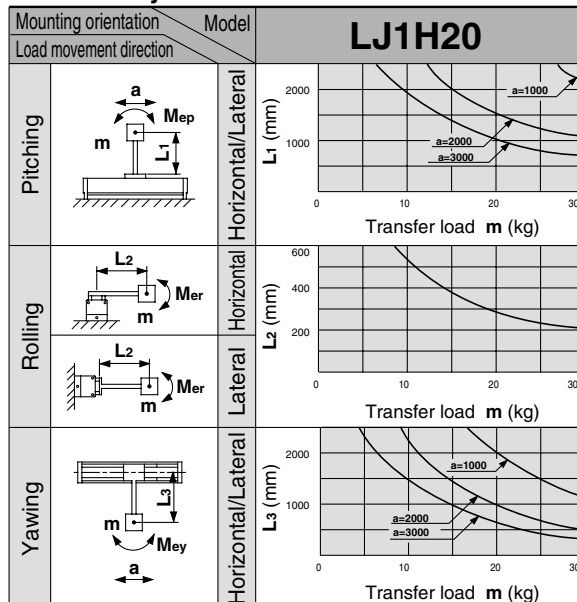

Refer to page 45 for deflection data.

Investigation of the regeneration option

Depending on the conditions (speed, addition-subtraction speed, down time, load, etc.), the regeneration option may be required. The results of consideration in each case of maximum load or half load for the product specification are below. Please consult SMC when considering the necessity of the regeneration option.

Maximum load

Driver type	Regeneration option model
A1	Not required.
A2	Not required.
B1	Not required.
B2	Not required.

Half load

Driver type	Regeneration option model
A1	Not required.
A2	Not required.
B1	Not required.
B2	Not required.

Dimensions/LJ1H20□NA

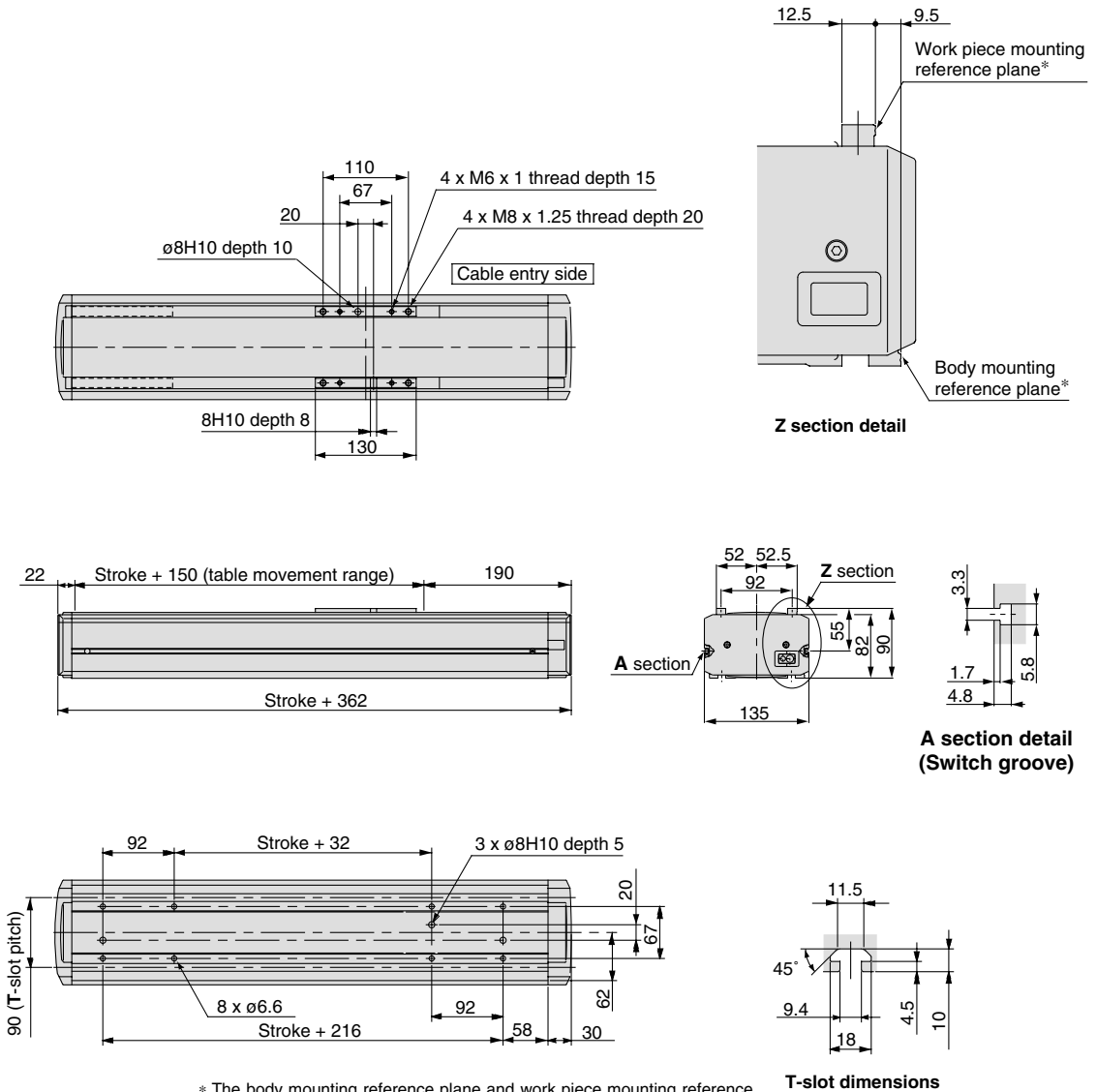

Positioning Time Guide

		Positioning time (sec.)				
		1	10	100	300	600
Speed (mm/s)	10	0.5	1.4	10.4	30.4	60.4
	100	0.5	0.6	1.5	3.5	6.5
	250	0.5	0.6	0.9	1.7	2.9
	500	0.5	0.6	0.8	1.2	1.8

* Values will vary slightly depending on the operating conditions.

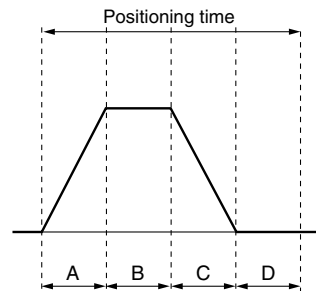

A: Acceleration time
 B: Constant velocity time
 C: Deceleration time
 D: Resting time (0.4 sec.)
 Maximum acceleration: 3000 mm/s²

Standard Motor Horizontal Mount Series LJ1H20

Motor Output
100 W

High Rigidity
Direct Acting
Guide

Rolled Ball Screw
∅15 mm/20 mm lead

How to Order

LJ1H20 S2 NC - 500 - F R 2 A1

Motor type

S2	AC servo motor (Incremental encoder) 100 W
S6	AC servo motor (Absolute encoder) 100 W

Stroke (mm)
Refer to the standard stroke.

Cable entry direction

F	Axial
R	Right
L	Left
T	Top
B	Bottom

Cable type

S	Standard cable
R	Robotic cable (flexible cable)

Cable length

2	2 m
5	5 m
A	10 m

IO connector

Nil	None
H	With IO connector

Auto switch

Nil	Without switch
1	NPN, A contact 1pc.
2	NPN, B contact 2pcs.
3	NPN, A contact 1pc., B contact 2pcs.
4	PNP, A contact 1pc.
5	PNP, B contact 2pcs.
6	PNP, A contact 1pc., B contact 2pcs.

Driver type

Nil	Without driver
A1	Pulse input type (Incremental encoder) 100 V
A2	Pulse input type (Incremental encoder) 200 V
B1	Pulse input type (Absolute encoder) 100 V
B2	Pulse input type (Absolute encoder) 200 V

Specifications

Standard stroke (mm)		500	600	700	800	900	1000
Performance	Body weight (kg)	12.6	13.7	14.5	15.3	17.2	18.6
	Operating temperature range (°C)	5 to 40 (No condensation)					
	Work load (kg)	30					
	Maximum speed (mm/s) ^{Note)}	1000	1000	930	740	600	500
	Positioning repeatability (mm)	±0.05					
Main parts	Motor	AC servo motor (100 W)					
	Encoder	Incremental system/Absolute type					
	Lead screw	Rolled ball screw ∅15 mm, 20 mm lead					
	Guide	High rigidity direct acting guide					
	Motor/Screw connection	With coupling					
Driver	Model	LECS□□-□ (Refer to page 97 for details.)					

Note) The speed is limited by the transfer load. Refer to the maximum speeds for each transfer load on the next page.

Allowable Moment (N·m)

Allowable static moment

Pitching	71
Rolling	83
Yawing	75

m : Transfer load (kg)
a : Work piece acceleration (mm/s²)
Me : Dynamic moment
L : Overhang to work piece center of gravity (mm)

Allowable dynamic moment

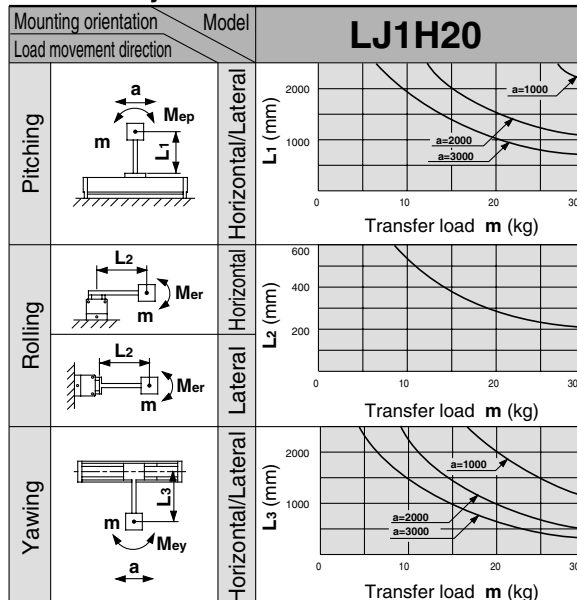

Refer to page 45 for deflection data.

Investigation of the regeneration option

Depending on the conditions (speed, addition-subtraction speed, down time, load, etc.), the regeneration option may be required. The results of consideration in each case of maximum load or half load for the product specification are below. Please consult SMC when considering the necessity of the regeneration option.

Maximum load

Driver type	Regeneration option model
A1	LEC-MR-RB-032
A2	Not required.
B1	LEC-MR-RB-032
B2	Not required.

Half load

Driver type	Regeneration option model
A1	Not required.
A2	Not required.
B1	Not required.
B2	Not required.

Series LJ1H20

Dimensions/LJ1H20□NC

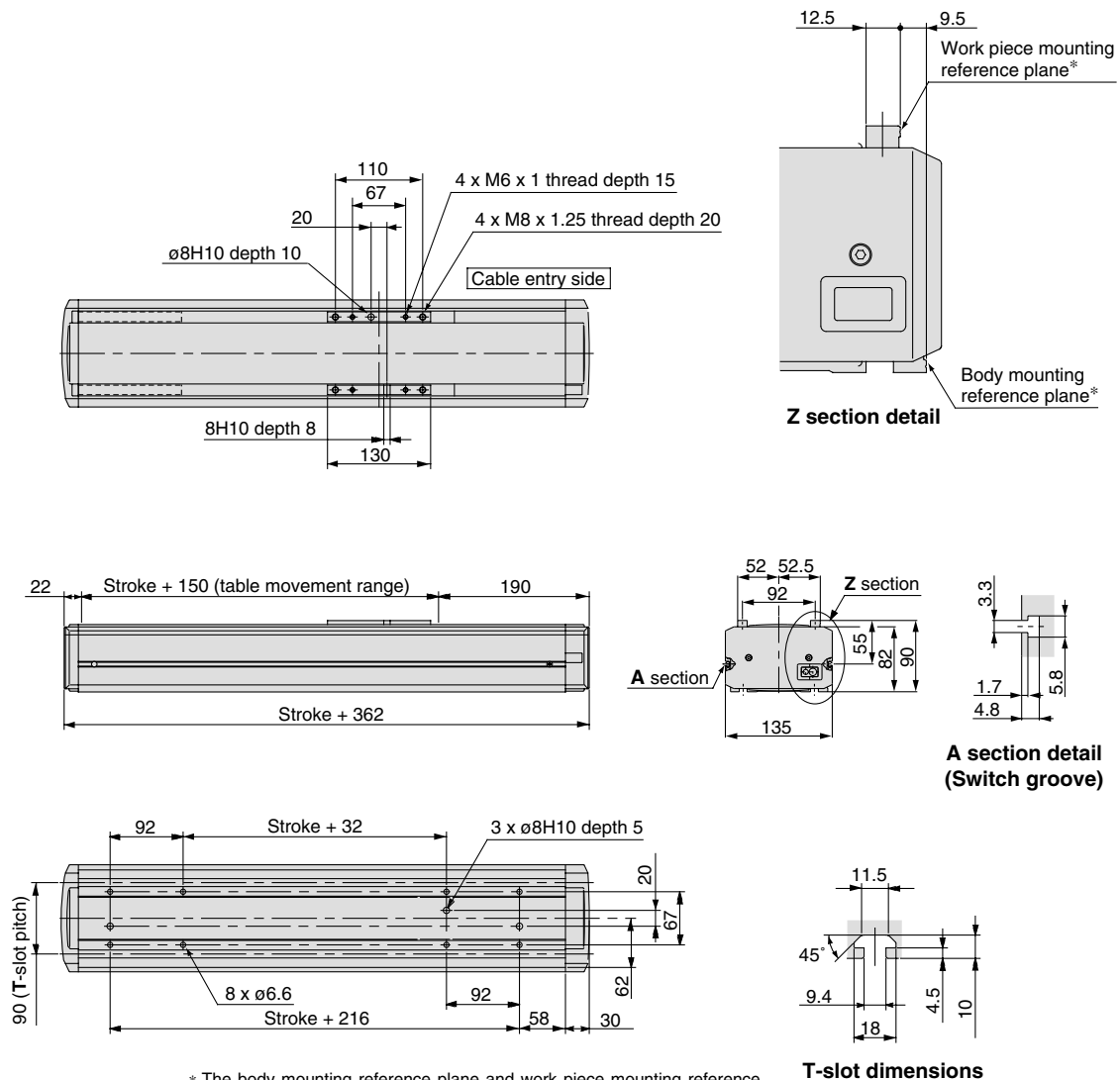

* The body mounting reference plane and work piece mounting reference plane should be used as standards when mounting onto equipment. Refer to pages starting with 42 for mounting.

Positioning Time Guide

		Positioning time (sec.)				
		1	10	100	500	1000
Speed (mm/s)	10	0.6	1.5	10.5	50.5	100.5
	100	0.5	0.6	1.5	5.5	10.5
	500	0.5	0.6	0.9	1.7	2.7
	1000	0.5	0.6	0.9	1.4	1.9

* Values will vary slightly depending on the operating conditions.

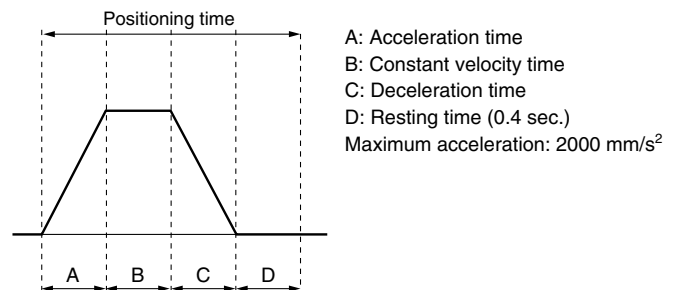

Maximum Speeds for Each Transfer Load

Model	Transfer load (kg)			
	15	20	25	30
LJ1H20□NC-500-□	1000	700	500	500
LJ1H20□NC-600-□	1000	700	500	500
LJ1H20□NC-700-□	930	600	500	500
LJ1H20□NC-800-□	740	600	500	500
LJ1H20□NC-900-□	600	500	500	500
LJ1H20□NC-1000-□	500	500	500	500

Unit (mm/s)

Standard Motor Horizontal Mount Series LJ1H30

Motor Output
200 W

High Rigidity
Direct Acting
Guide

Ground Ball Screw
∅25 mm/25 mm lead

How to Order

LJ1H30 S3 PD - 300 - F R 2 A1

Motor type

S3	AC servo motor (Incremental encoder) 200 W
S7	AC servo motor (Absolute encoder) 200 W

Stroke (mm)
Refer to the standard stroke.

Cable entry direction

F	Axial
R	Right
L	Left
T	Top
B	Bottom

Cable type

S	Standard cable
R	Robotic cable (flexible cable)

Cable length

2	2 m
5	5 m
A	10 m

IO connector

Nil	None
H	With IO connector

Auto switch

Nil	Without switch
1	NPN, A contact 1pc.
2	NPN, B contact 2pcs.
3	NPN, A contact 1pc., B contact 2pcs.
4	PNP, A contact 1pc.
5	PNP, B contact 2pcs.
6	PNP, A contact 1pc., B contact 2pcs.

Driver type

Nil	Without driver
A1	Pulse input type (Incremental encoder) 100 V
A2	Pulse input type (Incremental encoder) 200 V
B1	Pulse input type (Absolute encoder) 100 V
B2	Pulse input type (Absolute encoder) 200 V

Specifications

Standard stroke (mm)		200	300	400	500	600	800	1000	1200	1500
Performance	Body weight (kg)	16.0	18.0	20.0	22.0	24.0	28.5	33.0	37.0	43.0
	Operating temperature range (°C)	5 to 40 (No condensation)								
	Work load (kg)	60								
	Maximum speed (mm/s) ^{Note}	1000							700	500
	Positioning repeatability (mm)	±0.02								
Main parts	Motor	AC servo motor (200 W)								
	Encoder	Incremental system/Absolute type								
	Lead screw	Ground ball screw ∅25 mm, 25 mm lead								
	Guide	High rigidity direct acting guide								
	Motor/Screw connection	With coupling								
Driver	Model	LECS□□□□ (Refer to page 97 for details.)								

Note) The speed is limited by the transfer load. Refer to the maximum speeds for each transfer load on the next page.

Allowable Moment (N·m)

Allowable static moment

Pitching	117
Rolling	137
Yawing	123

m : Transfer load (kg)
a : Work piece acceleration (mm/s²)
Me : Dynamic moment
L : Overhang to work piece center of gravity (mm)

Allowable dynamic moment

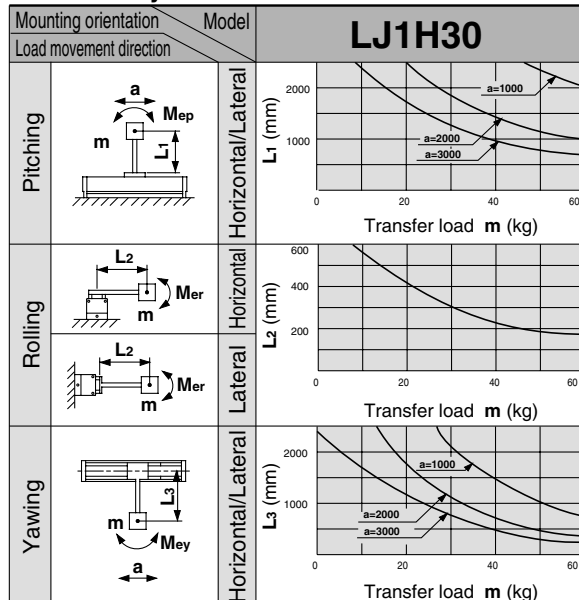

Refer to page 45 for deflection data.

Investigation of the regeneration option

Depending on the conditions (speed, addition-subtraction speed, down time, load, etc.), the regeneration option may be required. The results of consideration in each case of maximum load or half load for the product specification are below. Please consult SMC when considering the necessity of the regeneration option.

Maximum load

Driver type	Regeneration option model
A1	LEC-MR-RB-032
A2	Not required.
B1	LEC-MR-RB-032
B2	Not required.

Half load

Driver type	Regeneration option model
A1	Not required.
A2	Not required.
B1	Not required.
B2	Not required.

Series LJ1H30

Dimensions/LJ1H30□PD

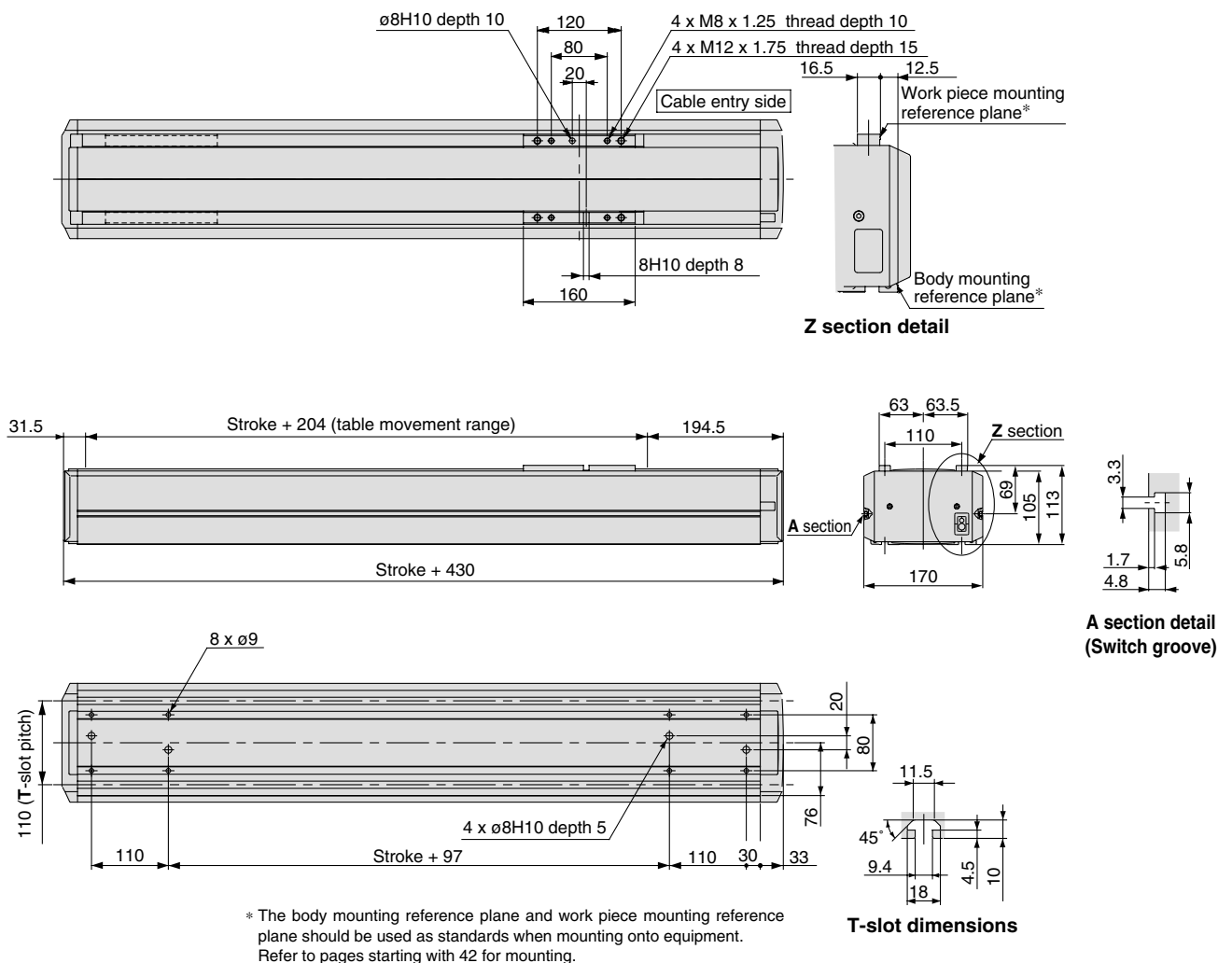

Positioning Time Guide

		Positioning time (sec.)				
		1	10	100	750	1500
Speed (mm/s)	10	1.1	2.0	11.0	76.0	151.0
	100	1.1	1.2	2.1	8.6	16.1
	500	1.1	1.2	1.4	2.7	4.2
	1000	1.1	1.2	1.4	2.1	2.9

* Values will vary slightly depending on the operating conditions.

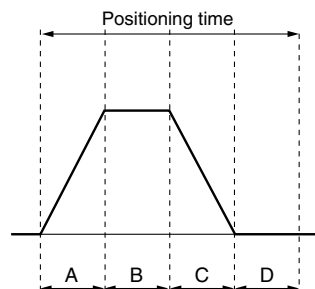

A: Acceleration time
 B: Constant velocity time
 C: Deceleration time
 D: Resting time (1.0 sec.)
 Maximum acceleration: 3000 mm/s²

Maximum Speeds for Each Transfer Load

Model	Transfer load (kg)					
	10	20	30	40	50	60
LJ1H30□PD-200~1000-□	1000	1000	1000	1000	900	800
LJ1H30□PD-1200-□	700	700	700	700	700	700
LJ1H30□PD-1500-□	500	500	500	500	500	500
LJ1H30□PD-200~1000-□	1000	900	800	700	650	600
LJ1H30□PD-1200-□	700	700	700	700	650	600
LJ1H30□PD-1500-□	500	500	500	500	500	500

* Consult SMC if outside of the above conditions.

Standard Motor Horizontal Mount

Motor Output
200 W

High Rigidity
Direct Acting
Guide

Rolled Ball Screw
∅25 mm/25 mm lead

Series LJ1H30

How to Order

LJ1H30 S3 ND - 300 - F R 2 A1

Motor type

S3	AC servo motor (Incremental encoder) 200 W
S7	AC servo motor (Absolute encoder) 200 W

Stroke (mm)
Refer to the standard stroke.

Cable entry direction

F	Axial
R	Right
L	Left
T	Top
B	Bottom

Cable type

S	Standard cable
R	Robotic cable (flexible cable)

Cable length

2	2 m
5	5 m
A	10 m

IO connector

Nil	None
H	With IO connector

Auto switch

Nil	Without switch
1	NPN, A contact 1pc.
2	NPN, B contact 2pcs.
3	NPN, A contact 1pc., B contact 2pcs.
4	PNP, A contact 1pc.
5	PNP, B contact 2pcs.
6	PNP, A contact 1pc., B contact 2pcs.

Driver type

Nil	Without driver
A1	Pulse input type (Incremental encoder) 100 V
A2	Pulse input type (Incremental encoder) 200 V
B1	Pulse input type (Absolute encoder) 100 V
B2	Pulse input type (Absolute encoder) 200 V

Specifications

Standard stroke (mm)		200	300	400	500	600	800	1000	1200	1500
Performance	Body weight (kg)	16.0	18.0	20.0	22.0	24.0	28.5	33.0	37.0	43.0
	Operating temperature range (°C)	5 to 40 (No condensation)								
	Work load (kg)	60								
	Maximum speed (mm/s) ^{Note)}	1000							700	500
	Positioning repeatability (mm)	±0.05								
Main parts	Motor	AC servo motor (200 W)								
	Encoder	Incremental system/Absolute type								
	Lead screw	Rolled ball screw ∅25 mm, 25 mm lead								
	Guide	High rigidity direct acting guide								
	Motor/Screw connection	With coupling								
Driver	Model	LECS□□-□ (Refer to page 97 for details.)								

Note) The speed is limited by the transfer load. Refer to the maximum speeds for each transfer load on the next page.

Allowable Moment (N·m)

Allowable static moment

Pitching	117
Rolling	137
Yawing	123

m : Transfer load (kg)
a : Work piece acceleration (mm/s²)
Me : Dynamic moment
L : Overhang to work piece center of gravity (mm)

Allowable dynamic moment

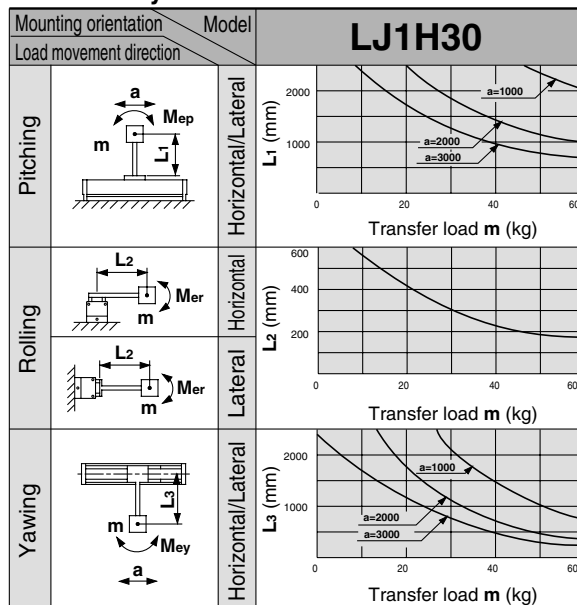

Refer to page 45 for deflection data.

Investigation of the regeneration option

Depending on the conditions (speed, addition-subtraction speed, down time, load, etc.), the regeneration option may be required. The results of consideration in each case of maximum load or half load for the product specification are below. Please consult SMC when considering the necessity of the regeneration option.

Maximum load

Driver type	Regeneration option model
A1	LEC-MR-RB-032
A2	Not required.
B1	LEC-MR-RB-032
B2	Not required.

Half load

Driver type	Regeneration option model
A1	Not required.
A2	Not required.
B1	Not required.
B2	Not required.

Dimensions/LJ1H30□ND

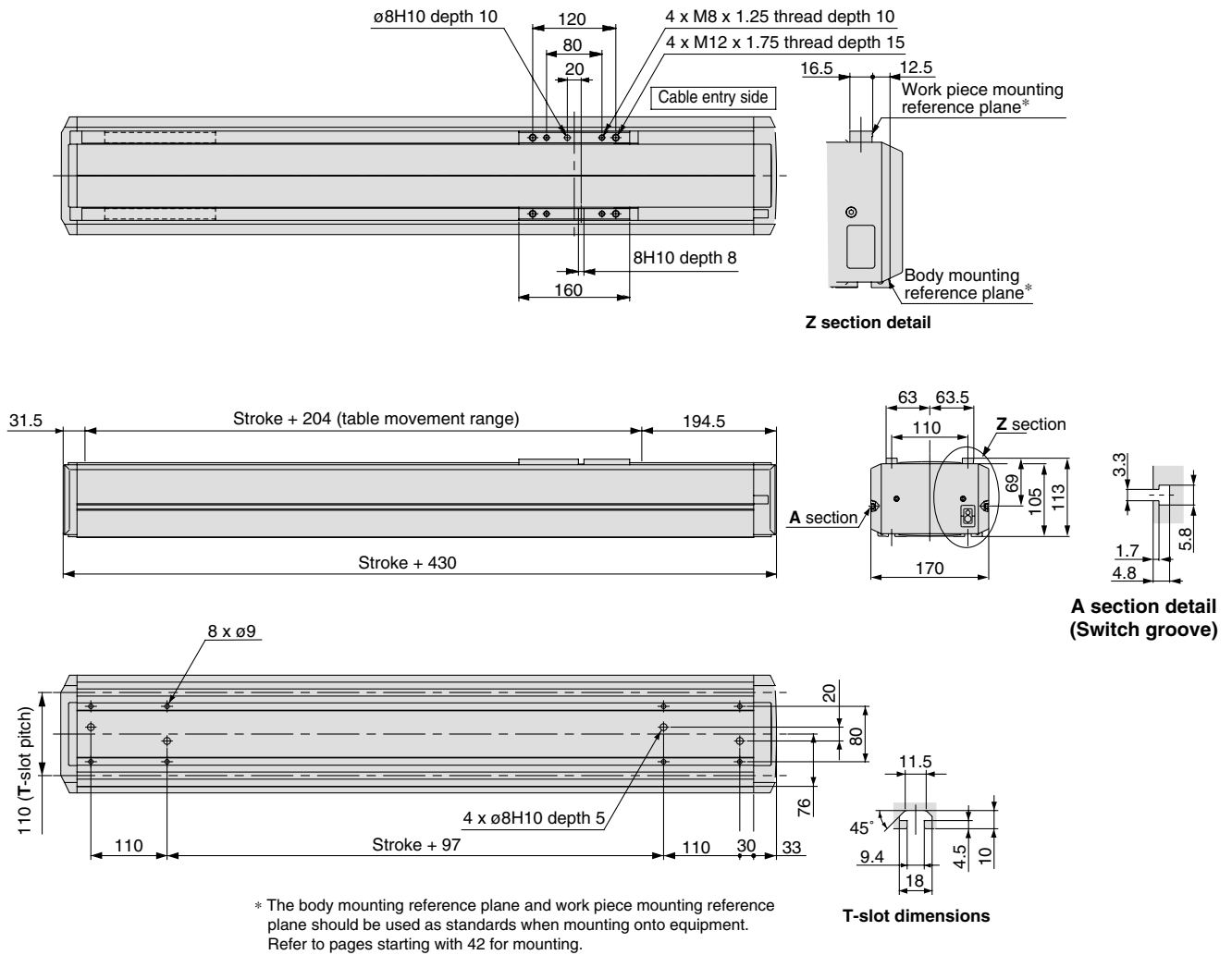

Positioning Time Guide

		Positioning time (sec.)				
		1	10	100	750	1500
Speed (mm/s)	10	1.1	2.0	11.0	76.0	151.0
	100	1.1	1.2	2.1	8.6	16.1
	500	1.1	1.2	1.4	2.7	4.2
	1000	1.1	1.2	1.4	2.1	2.9

* Values will vary slightly depending on the operating conditions.

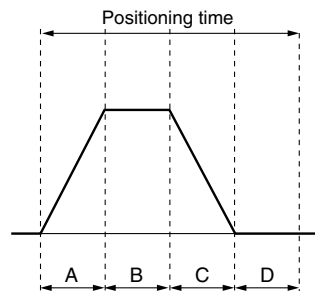

A: Acceleration time
 B: Constant velocity time
 C: Deceleration time
 D: Resting time (1.0 sec.)
 Maximum acceleration: 3000 mm/s²

Maximum Speeds for Each Transfer Load

Model	Transfer load (kg)					
	10	20	30	40	50	60
LJ1H30□ND-200 to 1000-□	1000	1000	1000	1000	900	800
LJ1H30□ND-1200-□	700	700	700	700	700	700
LJ1H30□ND-1500-□	500	500	500	500	500	500
LJ1H30□ND-200 to 1000-□	1000	900	800	700	650	600
LJ1H30□ND-1200-□	700	700	700	700	650	600
LJ1H30□ND-1500-□	500	500	500	500	500	500

* Consult SMC if outside of the above conditions.

Standard Motor Vertical Mount Series **LJ1H10**

Motor Output
100 W

High Rigidity
Direct Acting
Guide

Ground Ball Screw
∅12 mm/8 mm lead

How to Order

LJ1H10 S2 PH - 300 K - F R 2 A1 - [] - []

Motor type

S2	AC servo motor (Incremental encoder) 100 W
S6	AC servo motor (Absolute encoder) 100 W

Stroke (mm)
Refer to the standard stroke.

Cable entry direction

F	Axial
R	Right
L	Left
T	Top
B	Bottom

Cable type

S	Standard cable
R	Robotic cable (flexible cable)

Cable length

2	2 m
5	5 m
A	10 m

IO connector

Nil	None
H	With IO connector

Auto switch

Nil	Without switch
1	NPN, A contact 1pc.
2	NPN, B contact 2pcs.
3	NPN, A contact 1pc., B contact 2pcs.
4	PNP, A contact 1pc.
5	PNP, B contact 2pcs.
6	PNP, A contact 1pc., B contact 2pcs.

Driver type

Nil	Without driver
A1	Pulse input type (Incremental encoder) 100 V
A2	Pulse input type (Incremental encoder) 200 V
B1	Pulse input type (Absolute encoder) 100 V
B2	Pulse input type (Absolute encoder) 200 V

Cable entry direction

Specifications

Standard stroke (mm)		100	200	300	400	500
Performance	Body weight (kg)	5.5	6.3	7.1	7.8	8.6
	Operating temperature range (°C)	5 to 40 (No condensation)				
	Work load (kg)	10				
	Maximum speed (mm/s)	400				
	Positioning repeatability (mm)	±0.02				
Main parts	Motor	AC servo motor (100 W) with lock				
	Encoder	Incremental system/Absolute type				
	Lead screw	Ground ball screw ∅12 mm, 8 mm lead				
	Guide	High rigidity direct acting guide				
Driver	Motor/Screw connection	With coupling				
	Model	LECS□□-□ (Refer to page 97 for details.)				

Allowable Moment (N·m)

Allowable static moment

Pitching	10.2
Yawing	10.2

m : Transfer load (kg)
a : Work piece acceleration (mm/s²)
Me : Dynamic moment
L : Overhang to work piece center of gravity (mm)

Allowable dynamic moment

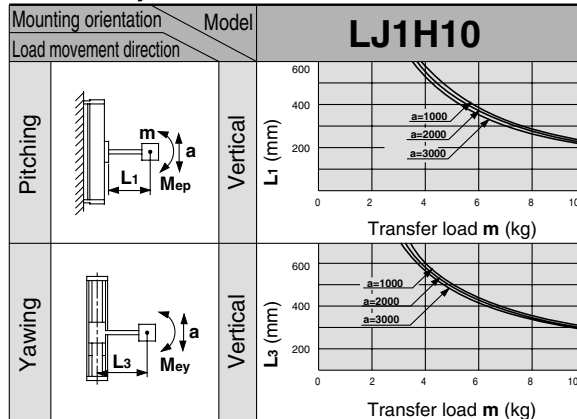

Refer to page 45 for deflection data.

Note) When using this product, the regeneration option may be required.

Investigation of the regeneration option

Depending on the conditions (speed, addition-subtraction speed, down time, load, etc.), the regeneration option may be required. The results of consideration in each case of maximum load or half load for the product specification are below. Please consult SMC when considering the necessity of the regeneration option.

Maximum load

Driver type	Regeneration option model
A1	LEC-MR-RB-032
A2	LEC-MR-RB-032
B1	LEC-MR-RB-032
B2	LEC-MR-RB-032

Half load

Driver type	Regeneration option model
A1	LEC-MR-RB-032
A2	LEC-MR-RB-032
B1	LEC-MR-RB-032
B2	LEC-MR-RB-032

Series LJ1H10

Dimensions/LJ1H10□PH

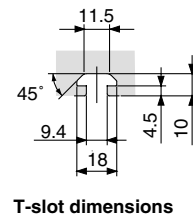
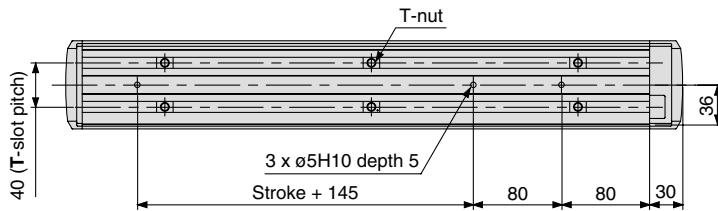
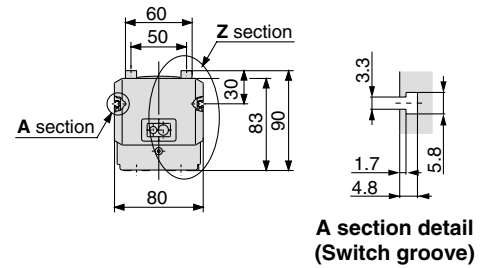
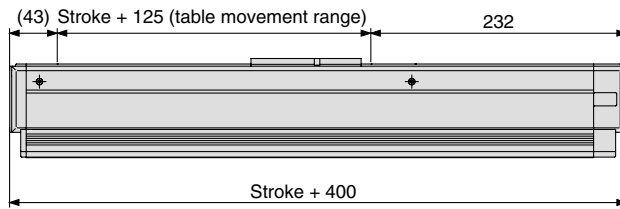
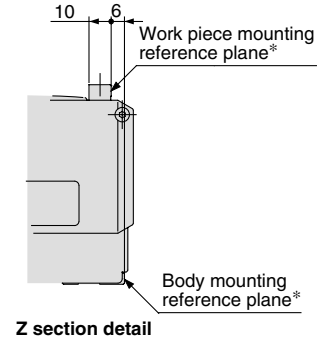
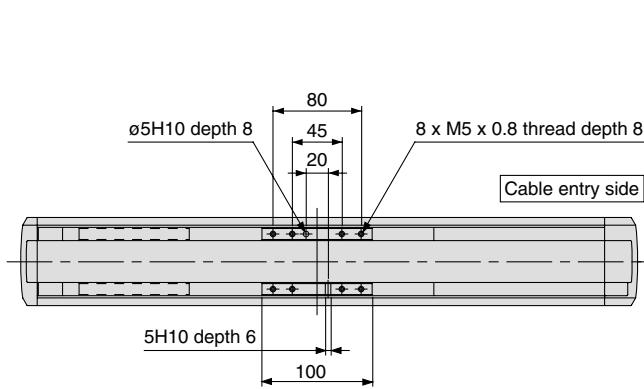

* The body mounting reference plane and work piece mounting reference plane should be used as standards when mounting onto equipment. Refer to pages starting with 42 for mounting.

Positioning Time Guide

		Positioning time (sec.)				
		1	10	100	250	500
Speed (mm/s)	10	0.4	1.3	10.3	25.3	50.3
	100	0.4	0.5	1.4	2.9	5.4
	200	0.4	0.5	0.9	1.7	2.9
	400	0.4	0.5	0.7	1.1	1.7

* Values will vary slightly depending on the operating conditions.

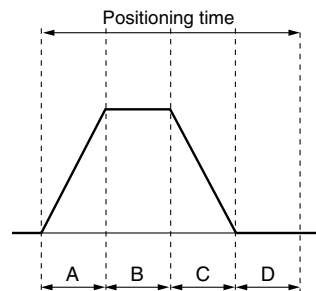

A: Acceleration time
 B: Constant velocity time
 C: Deceleration time
 D: Resting time (0.3 sec.)
 Maximum acceleration: 3000 mm/s²

Standard Motor Vertical Mount Series LJ1H10

Motor Output
100 W

High Rigidity
Direct Acting
Guide

Ground Ball Screw
∅12 mm/12 mm lead

How to Order

LJ1H10 S2 PB - 300 K - F R 2 A1

Motor type

S2	AC servo motor (Incremental encoder) 100 W
S6	AC servo motor (Absolute encoder) 100 W

Stroke (mm)
Refer to the standard stroke.

Cable entry direction

F	Axial
R	Right
L	Left
T	Top
B	Bottom

Cable type

S	Standard cable
R	Robotic cable (flexible cable)

Cable length

2	2 m
5	5 m
A	10 m

IO connector

Nil	None
H	With IO connector

Auto switch

Nil	Without switch
1	NPN, A contact 1pc.
2	NPN, B contact 2pcs.
3	NPN, A contact 1pc., B contact 2pcs.
4	PNP, A contact 1pc.
5	PNP, B contact 2pcs.
6	PNP, A contact 1pc., B contact 2pcs.

Driver type

Nil	Without driver
A1	Pulse input type (Incremental encoder) 100 V
A2	Pulse input type (Incremental encoder) 200 V
B1	Pulse input type (Absolute encoder) 100 V
B2	Pulse input type (Absolute encoder) 200 V

Cable entry direction

Specifications

Standard stroke (mm)		100	200	300	400	500
Performance	Body weight (kg)	5.5	6.3	7.1	7.8	8.6
	Operating temperature range (°C)	5 to 40 (No condensation)				
	Work load (kg)	5				
	Maximum speed (mm/s)	600				
	Positioning repeatability (mm)	±0.02				
Main parts	Motor	AC servo motor (100 W) with lock				
	Encoder	Incremental system/Absolute type				
	Lead screw	Ground ball screw ∅12 mm, 12 mm lead				
	Guide	High rigidity direct acting guide				
Motor/Screw connection	With coupling					
Driver	Model	LECS□□-□ (Refer to page 97 for details.)				

Allowable Moment (N·m)

Allowable static moment

Pitching	10.2
Yawing	10.2

m : Transfer load (kg)
a : Work piece acceleration (mm/s²)
Me : Dynamic moment
L : Overhang to work piece center of gravity (mm)

Allowable dynamic moment

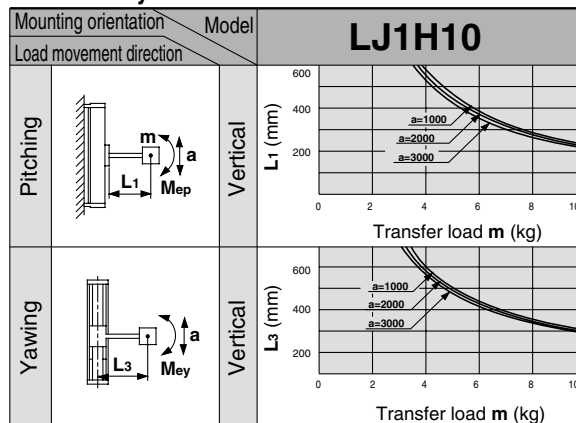

Refer to page 45 for deflection data.

Note) When using this product, the regeneration option may be required.

Investigation of the regeneration option

Depending on the conditions (speed, addition-subtraction speed, down time, load, etc.), the regeneration option may be required. The results of consideration in each case of maximum load or half load for the product specification are below. Please consult SMC when considering the necessity of the regeneration option.

Maximum load

Driver type	Regeneration option model
A1	LEC-MR-RB-032
A2	LEC-MR-RB-032
B1	LEC-MR-RB-032
B2	LEC-MR-RB-032

Half load

Driver type	Regeneration option model
A1	Not required.
A2	Not required.
B1	Not required.
B2	Not required.

Series LJ1H10

Dimensions/LJ1H10□PB

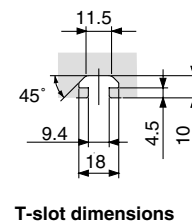
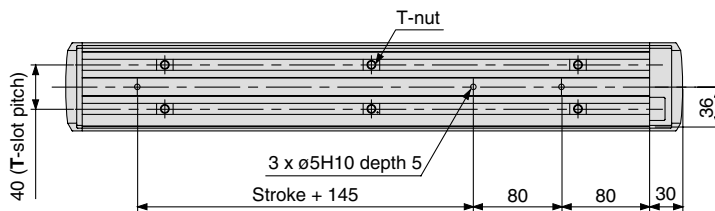
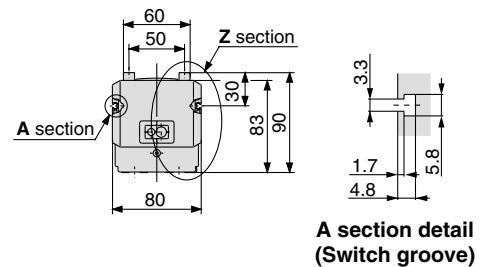
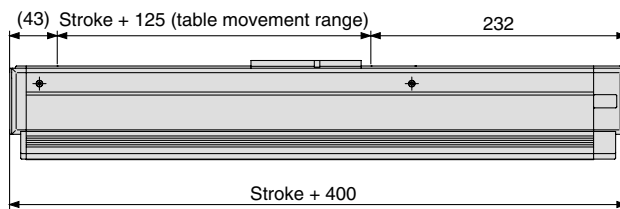
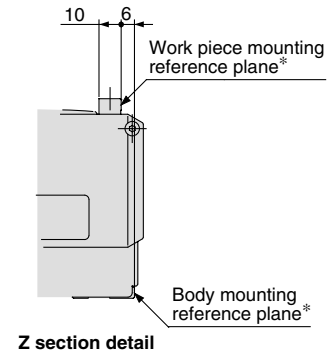
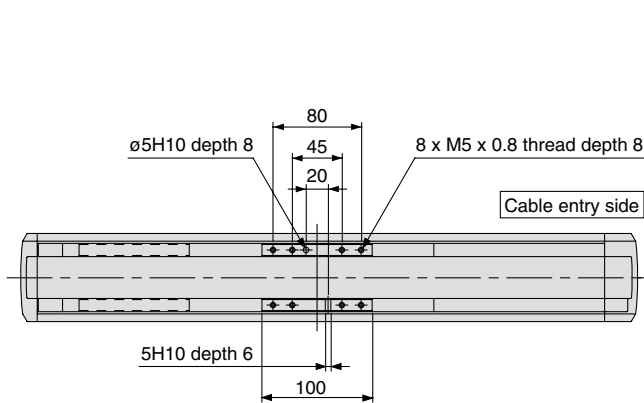

* The body mounting reference plane and work piece mounting reference plane should be used as standards when mounting onto equipment. Refer to pages starting with 42 for mounting.

Positioning Time Guide

		Positioning time (sec.)				
		1	10	100	250	500
Speed (mm/s)	10	0.4	1.3	10.3	25.3	50.3
	100	0.4	0.5	1.4	2.9	5.4
	300	0.4	0.5	0.8	1.3	2.1
	600	0.4	0.5	0.7	1.0	1.4

* Values will vary slightly depending on the operating conditions.

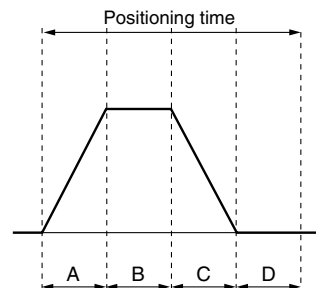

A: Acceleration time
 B: Constant velocity time
 C: Deceleration time
 D: Resting time (0.3 sec.)
 Maximum acceleration: 3000 mm/s²

Standard Motor Vertical Mount Series **LJ1H10**

Motor Output
100 W

High Rigidity
Direct Acting
Guide

Rolled Ball Screw
∅12 mm/8 mm lead

How to Order

LJ1H10 **S2** **NH** - **300** **K** - **F** **R** **2** **A1** - -

Motor type

S2	AC servo motor (Incremental encoder) 100 W
S6	AC servo motor (Absolute encoder) 100 W

Stroke (mm)
Refer to the standard stroke.

Cable entry direction

F	Axial
R	Right
L	Left
T	Top
B	Bottom

Cable type

S	Standard cable
R	Robotic cable (flexible cable)

Cable length

2	2m
5	5 m
A	10 m

IO connector

Nil	None
H	With IO connector

Auto switch

Nil	Without switch
1	NPN, A contact 1pc.
2	NPN, B contact 2pcs.
3	NPN, A contact 1pc., B contact 2pcs.
4	PNP, A contact 1pc.
5	PNP, B contact 2pcs.
6	PNP, A contact 1pc., B contact 2pcs.

Driver type

Nil	Without driver
A1	Pulse input type (Incremental encoder) 100 V
A2	Pulse input type (Incremental encoder) 200 V
B1	Pulse input type (Absolute encoder) 100 V
B2	Pulse input type (Absolute encoder) 200 V

Cable entry direction

Specifications

Standard stroke (mm)		100	200	300	400	500
Performance	Body weight (kg)	5.5	6.3	7.1	7.8	8.6
	Operating temperature range (°C)	5 to 40 (No condensation)				
	Work load (kg)	10				
	Maximum speed (mm/s)	400				
	Positioning repeatability (mm)	±0.05				
Main parts	Motor	AC servo motor (100 W) with lock				
	Encoder	Incremental system/Absolute type				
	Lead screw	Rolled ball screw ∅12 mm, 8 mm lead				
	Guide	High rigidity direct acting guide				
	Motor/Screw connection	With coupling				
Driver	Model	LECS□□-□ (Refer to page 97 for details.)				

Allowable Moment (N·m)

Allowable static moment

Pitching	10.2
Yawing	10.2

m : Transfer load (kg)
a : Work piece acceleration (mm/s²)
Me : Dynamic moment
L : Overhang to work piece center of gravity (mm)

Allowable dynamic moment

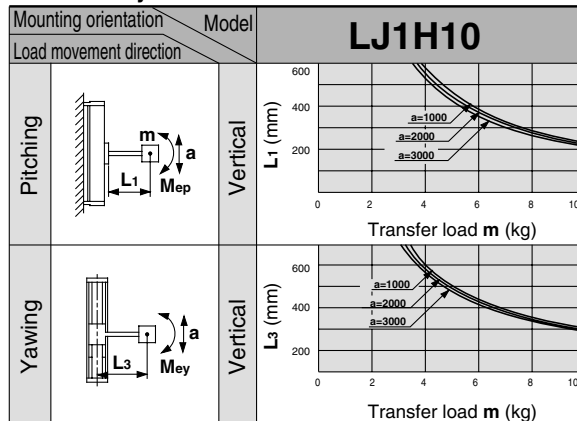

Refer to page 45 for deflection data.

Note) When using this product, the regeneration option may be required.

Investigation of the regeneration option

Depending on the conditions (speed, addition-subtraction speed, down time, load, etc.), the regeneration option may be required. The results of consideration in each case of maximum load or half load for the product specification are below. Please consult SMC when considering the necessity of the regeneration option.

Maximum load

Driver type	Regeneration option model
A1	LEC-MR-RB-032
A2	LEC-MR-RB-032
B1	LEC-MR-RB-032
B2	LEC-MR-RB-032

Half load

Driver type	Regeneration option model
A1	LEC-MR-RB-032
A2	LEC-MR-RB-032
B1	LEC-MR-RB-032
B2	LEC-MR-RB-032

Series LJ1H10

Dimensions/LJ1H10□NH

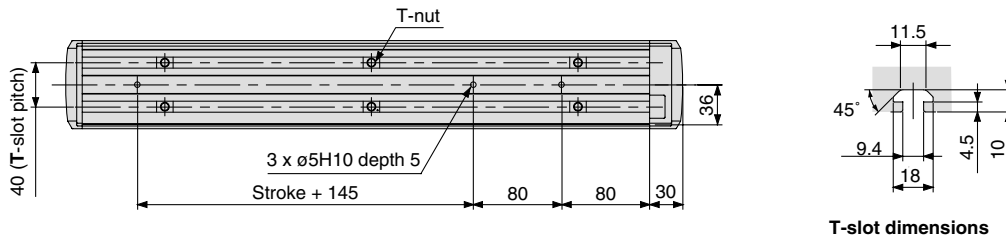
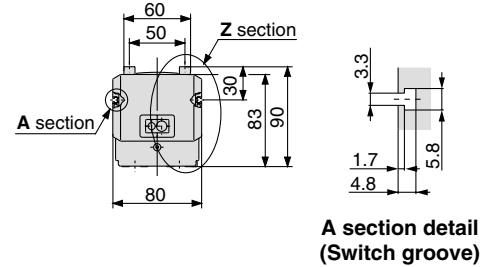
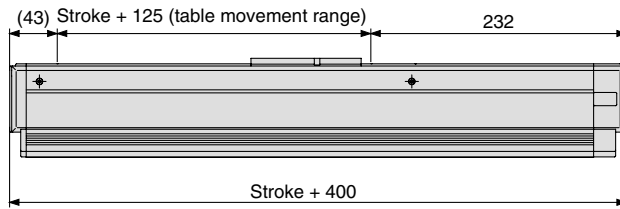
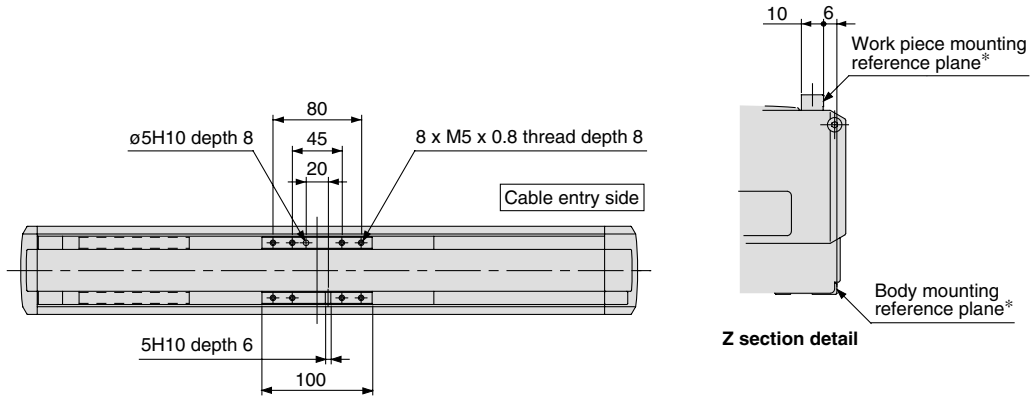

* The body mounting reference plane and work piece mounting reference plane should be used as standards when mounting onto equipment. Refer to pages starting with 42 for mounting.

Positioning Time Guide

		Positioning time (sec.)				
		1	10	100	250	500
Speed (mm/s)	10	0.4	1.3	10.3	25.3	50.3
	100	0.4	0.5	1.4	2.9	5.4
	200	0.4	0.5	0.9	1.7	2.9
	400	0.4	0.5	0.7	1.1	1.7

* Values will vary slightly depending on the operating conditions.

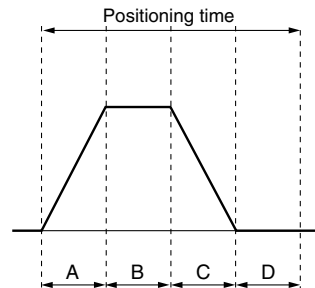

A: Acceleration time
 B: Constant velocity time
 C: Deceleration time
 D: Resting time (0.3 sec.)
 Maximum acceleration: 3000 mm/s²

Standard Motor Vertical Mount Series LJ1H10

Motor Output
100 W

High Rigidity
Direct Acting
Guide

Rolled Ball Screw
∅12 mm/12 mm lead

How to Order

LJ1H10 **S2** **NB** - **300** **K** - **F** **R** **2** **A1** - -

Motor type

S2	AC servo motor (Incremental encoder) 100 W
S6	AC servo motor (Absolute encoder) 100 W

Stroke (mm)
Refer to the standard stroke.

Cable entry direction

F	Axial
R	Right
L	Left
T	Top
B	Bottom

Cable type

S	Standard cable
R	Robotic cable (flexible cable)

Cable length

2	2 m
5	5 m
A	10 m

IO connector

Nil	None
H	With IO connector

Auto switch

Nil	Without switch
1	NPN, A contact 1pc.
2	NPN, B contact 2pcs.
3	NPN, A contact 1pc., B contact 2pcs.
4	PNP, A contact 1pc.
5	PNP, B contact 2pcs.
6	PNP, A contact 1pc., B contact 2pcs.

Driver type

Nil	Without driver
A1	Pulse input type (Incremental encoder) 100 V
A2	Pulse input type (Incremental encoder) 200 V
B1	Pulse input type (Absolute encoder) 100 V
B2	Pulse input type (Absolute encoder) 200 V

Cable entry direction

Specifications

Standard stroke (mm)		100	200	300	400	500
Performance	Body weight (kg)	5.5	6.3	7.1	7.8	8.6
	Operating temperature range (°C)	5 to 40 (No condensation)				
	Work load (kg)	5				
	Maximum speed (mm/s)	600				
	Positioning repeatability (mm)	±0.05				
Main parts	Motor	AC servo motor (100 W) with lock				
	Encoder	Incremental system/Absolute type				
	Lead screw	Rolled ball screw ∅12 mm, 12 mm lead				
	Guide	High rigidity direct acting guide				
	Motor/Screw connection	With coupling				
Driver	Model	LECS□□-□ (Refer to page 97 for details.)				

Allowable Moment (N·m)

Allowable static moment

Pitching	10.2
Yawing	10.2

m : Transfer load (kg)
a : Work piece acceleration (mm/s²)
Me : Dynamic moment
L : Overhang to work piece center of gravity (mm)

Allowable dynamic moment

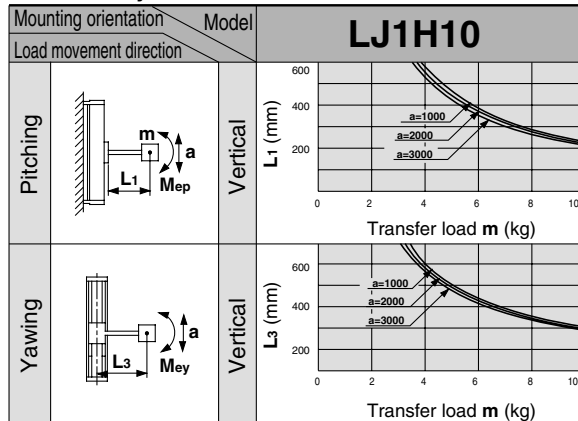

Refer to page 45 for deflection data.

Note) When using this product, the regeneration option may be required.

Investigation of the regeneration option

Depending on the conditions (speed, addition-subtraction speed, down time, load, etc.), the regeneration option may be required. The results of consideration in each case of maximum load or half load for the product specification are below. Please consult SMC when considering the necessity of the regeneration option.

Maximum load

Driver type	Regeneration option model
A1	LEC-MR-RB-032
A2	LEC-MR-RB-032
B1	LEC-MR-RB-032
B2	LEC-MR-RB-032

Half load

Driver type	Regeneration option model
A1	Not required.
A2	Not required.
B1	Not required.
B2	Not required.

Series LJ1H10

Dimensions/LJ1H10□NB

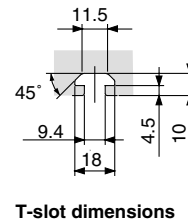
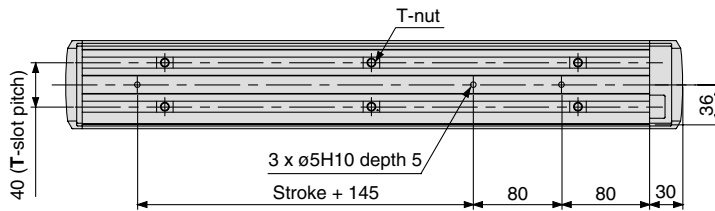
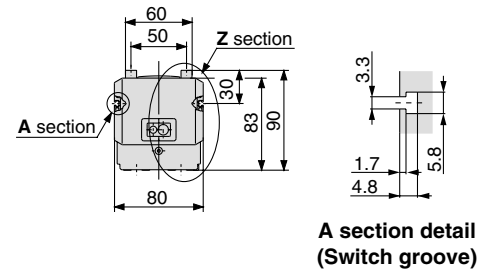
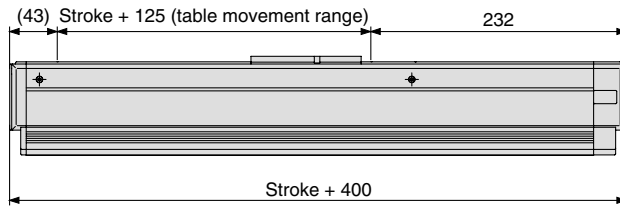
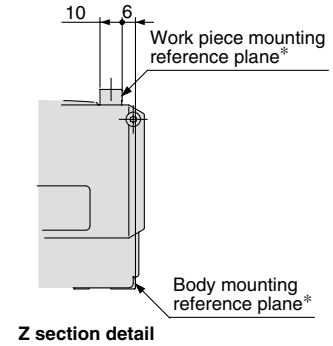
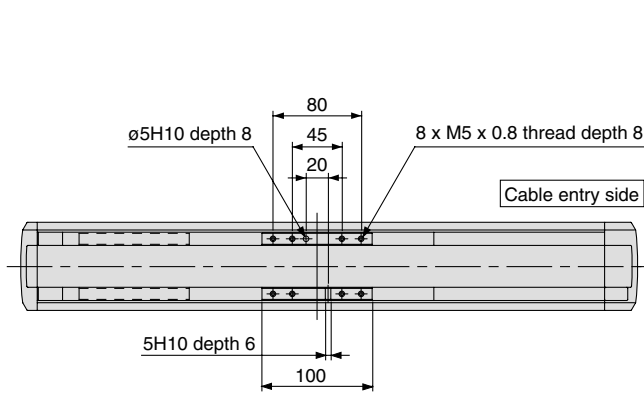

* The body mounting reference plane and work piece mounting reference plane should be used as standards when mounting onto equipment. Refer to pages starting with 42 for mounting.

Positioning Time Guide

		Positioning time (sec.)				
Positioning distance (mm)		1	10	100	250	500
Speed (mm/s)	10	0.4	1.3	10.3	25.3	50.3
	100	0.4	0.5	1.4	2.9	5.4
	300	0.4	0.5	0.8	1.3	2.1
	600	0.4	0.5	0.7	1.0	1.4

* Values will vary slightly depending on the operating conditions.

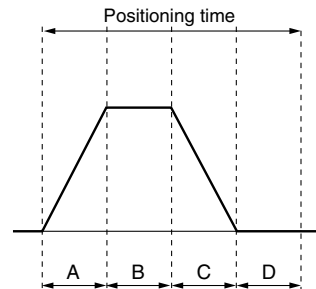

A: Acceleration time
 B: Constant velocity time
 C: Deceleration time
 D: Resting time (0.3 sec.)
 Maximum acceleration: 3000 mm/s²

Standard Motor Vertical Mount Series LJ1H20

Motor Output
100 W

High Rigidity
Direct Acting
Guide

Ground Ball Screw
∅15 mm/5 mm lead

How to Order

LJ1H20 S2 PF - 300 K - F R 2 A1

Motor type

S2	AC servo motor (Incremental encoder) 100 W
S6	AC servo motor (Absolute encoder) 100 W

Stroke (mm)
Refer to the standard stroke.

Cable entry direction

F	Axial
R	Right
L	Left
T	Top
B	Bottom

Cable type

S	Standard cable
R	Robotic cable (flexible cable)

Cable length

2	2 m
5	5 m
A	10 m

IO connector

Nil	None
H	With IO connector

Auto switch

Nil	Without switch
1	NPN, A contact 1pc.
2	NPN, B contact 2pcs.
3	NPN, A contact 1pc., B contact 2pcs.
4	PNP, A contact 1pc.
5	PNP, B contact 2pcs.
6	PNP, A contact 1pc., B contact 2pcs.

Driver type

Nil	Without driver
A1	Pulse input type (Incremental encoder) 100 V
A2	Pulse input type (Incremental encoder) 200 V
B1	Pulse input type (Absolute encoder) 100 V
B2	Pulse input type (Absolute encoder) 200 V

Cable entry direction

Specifications

Standard stroke (mm)		100	200	300	400	500	600
Performance	Body weight (kg)	8.0	9.2	10.4	11.5	12.9	14.0
	Operating temperature range (°C)	5 to 40 (No condensation)					
	Work load (kg)	15					
	Maximum speed (mm/s)	250					
	Positioning repeatability (mm)	±0.02					
Main parts	Motor	AC servo motor (100 W) with lock					
	Encoder	Incremental system/Absolute type					
	Lead screw	Ground ball screw ∅15 mm, 5 mm lead					
	Guide	High rigidity direct acting guide					
	Motor/Screw connection	With coupling					
Driver	Model	LECS□□-□ (Refer to page 97 for details.)					

Allowable Moment (N·m)

Allowable static moment

Pitching	71
Yawing	75

m : Transfer load (kg)
a : Work piece acceleration (mm/s²)
Me : Dynamic moment
L : Overhang to work piece center of gravity (mm)

Allowable dynamic moment

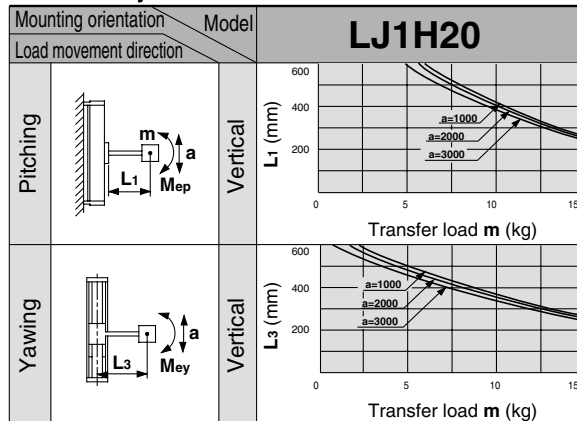

Refer to page 45 for deflection data.

Note) When using this product, the regeneration option may be required.

Investigation of the regeneration option

Depending on the conditions (speed, addition-subtraction speed, down time, load, etc.), the regeneration option may be required. The results of consideration in each case of maximum load or half load for the product specification are below. Please consult SMC when considering the necessity of the regeneration option.

Maximum load

Driver type	Regeneration option model
A1	LEC-MR-RB-032
A2	LEC-MR-RB-032
B1	LEC-MR-RB-032
B2	LEC-MR-RB-032

Half load

Driver type	Regeneration option model
A1	LEC-MR-RB-032
A2	LEC-MR-RB-032
B1	LEC-MR-RB-032
B2	LEC-MR-RB-032

Series LJ1H20

Dimensions/LJ1H20□PF

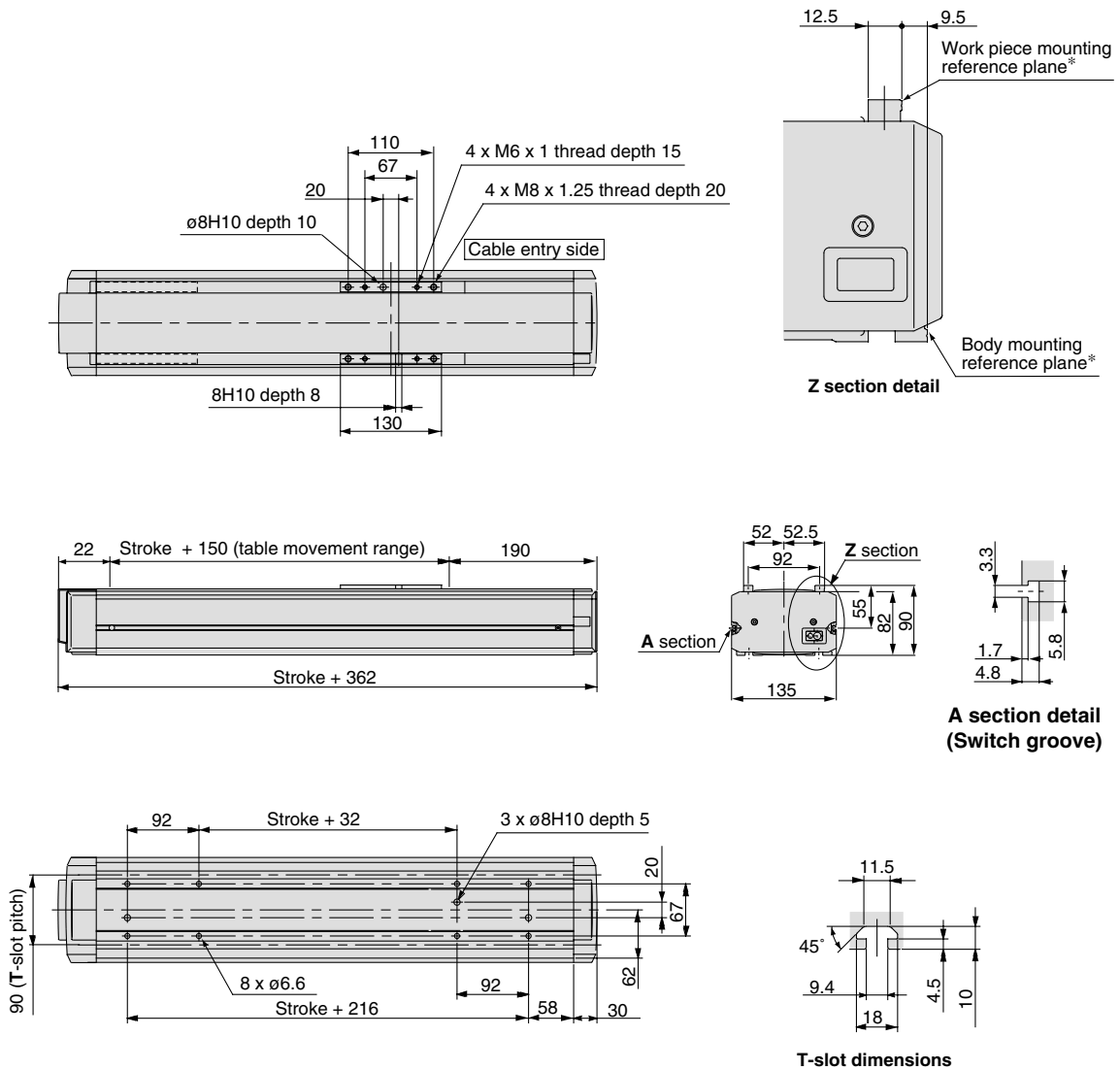

* The body mounting reference plane and work piece mounting reference plane should be used as standards when mounting onto equipment. Refer to pages starting with 42 for mounting.

Positioning Time Guide

		Positioning time (sec.)				
Positioning distance (mm)		1	10	100	300	600
Speed (mm/s)	10	0.5	1.4	10.4	30.4	60.4
	100	0.5	0.6	1.5	3.5	6.5
	125	0.5	0.6	1.3	2.9	5.3
	250	0.5	0.6	0.9	1.7	2.9

* Values will vary slightly depending on the operating conditions.

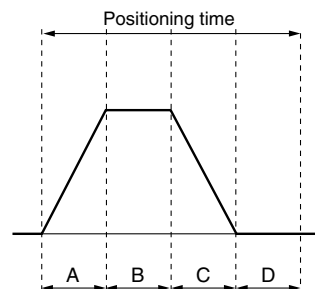

A: Acceleration time
 B: Constant velocity time
 C: Deceleration time
 D: Resting time (0.4 sec.)
 Maximum acceleration: 3000 mm/s²

Standard Motor Vertical Mount Series **LJ1H20**

Motor Output
100 W

High Rigidity
Direct Acting
Guide

Ground Ball Screw
∅15 mm/10 mm lead

How to Order

LJ1H20 **S2** **PA** - **300** **K** - **F** **R** **2** **A1** - [] - []

Motor type

S2	AC servo motor (Incremental encoder) 100 W
S6	AC servo motor (Absolute encoder) 100 W

Stroke (mm)
Refer to the standard stroke.

Cable entry direction

F	Axial
R	Right
L	Left
T	Top
B	Bottom

Cable type

S	Standard cable
R	Robotic cable (flexible cable)

Cable length

2	2 m
5	5 m
A	10 m

IO connector

Nil	None
H	With IO connector

Auto switch

Nil	Without switch
1	NPN, A contact 1pc.
2	NPN, B contact 2pcs.
3	NPN, A contact 1pc., B contact 2pcs.
4	PNP, A contact 1pc.
5	PNP, B contact 2pcs.
6	PNP, A contact 1pc., B contact 2pcs.

Driver type

Nil	Without driver
A1	Pulse input type (Incremental encoder) 100 V
A2	Pulse input type (Incremental encoder) 200 V
B1	Pulse input type (Absolute encoder) 100 V
B2	Pulse input type (Absolute encoder) 200 V

Cable entry direction

Specifications

Standard stroke (mm)		100	200	300	400	500	600
Performance	Body weight (kg)	8.0	9.2	10.4	11.5	12.9	14.0
	Operating temperature range (°C)	5 to 40 (No condensation)					
	Work load (kg)	8					
	Maximum speed (mm/s)	500					
	Positioning repeatability (mm)	±0.02					
Main parts	Motor	AC servo motor (100 W) with lock					
	Encoder	Incremental system/Absolute type					
	Lead screw	Ground ball screw ∅15 mm, 10 mm lead					
	Guide	High rigidity direct acting guide					
	Motor/Screw connection	With coupling					
Driver	Model	LECS□□□□ (Refer to page 97 for details.)					

Allowable Moment (N·m)

Allowable static moment

Pitching	71
Yawing	75

m : Transfer load (kg)
a : Work piece acceleration (mm/s²)
Me : Dynamic moment
L : Overhang to work piece center of gravity (mm)

Allowable dynamic moment

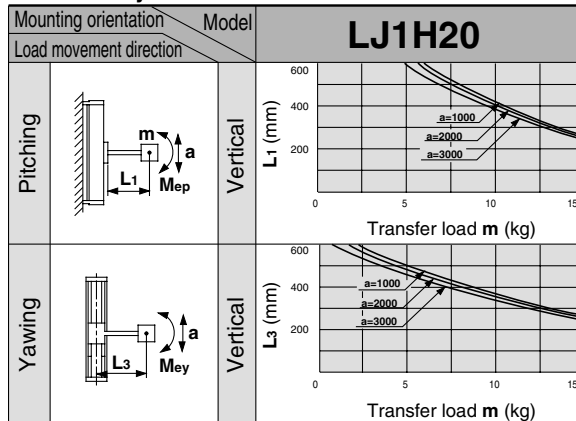

Refer to page 45 for deflection data.

Note) When using this product, the regeneration option may be required.

Investigation of the regeneration option

Depending on the conditions (speed, addition-subtraction speed, down time, load, etc.), the regeneration option may be required. The results of consideration in each case of maximum load or half load for the product specification are below. Please consult SMC when considering the necessity of the regeneration option.

Maximum load

Driver type	Regeneration option model
A1	LEC-MR-RB-032
A2	LEC-MR-RB-032
B1	LEC-MR-RB-032
B2	LEC-MR-RB-032

Half load

Driver type	Regeneration option model
A1	LEC-MR-RB-032
A2	LEC-MR-RB-032
B1	LEC-MR-RB-032
B2	LEC-MR-RB-032

Series LJ1H20

Dimensions/LJ1H20□PA

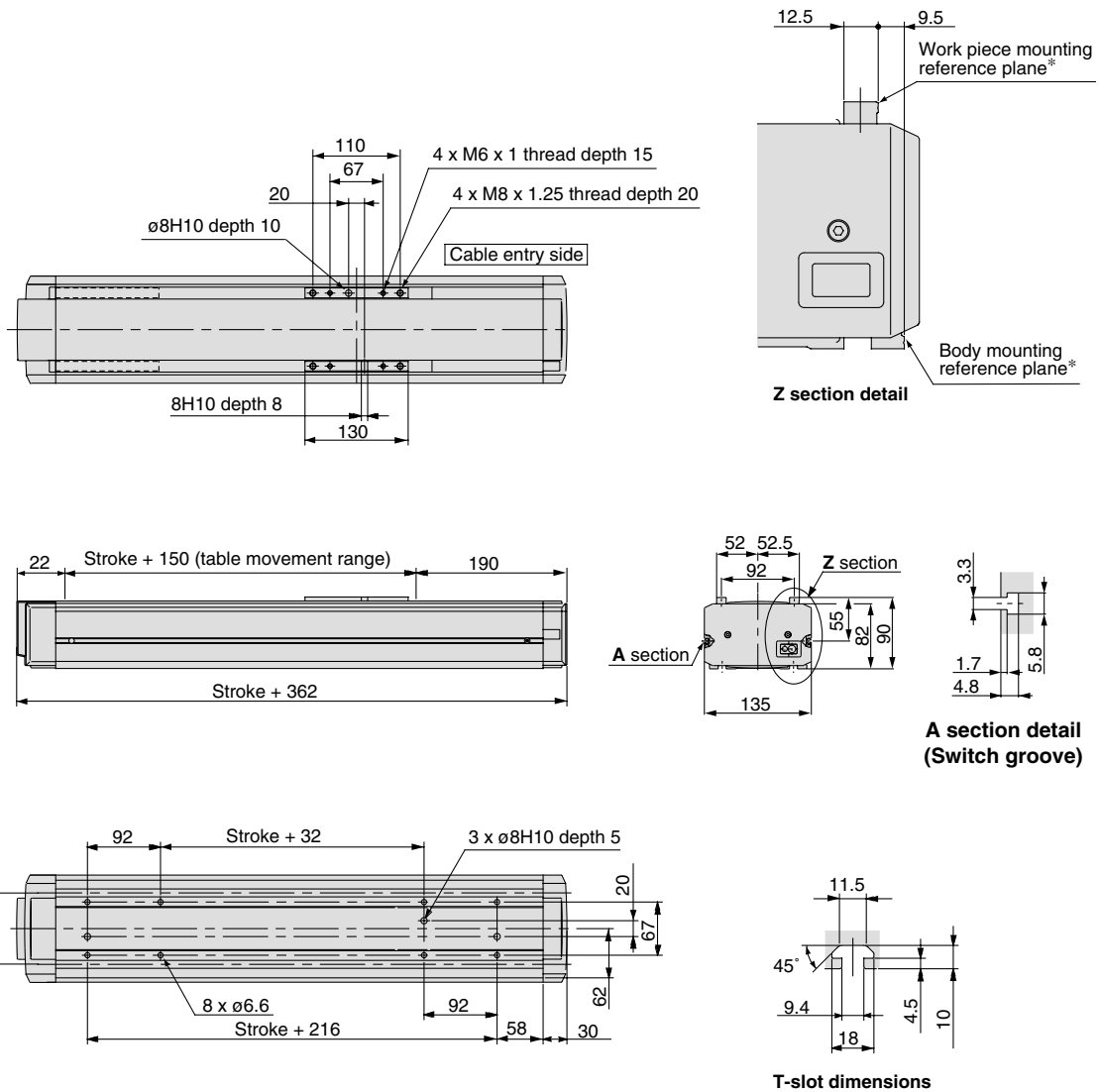

* The body mounting reference plane and work piece mounting reference plane should be used as standards when mounting onto equipment. Refer to pages starting with 42 for mounting.

Positioning Time Guide

		Positioning time (sec.)				
Positioning distance (mm)		1	10	100	300	600
Speed (mm/s)	10	0.5	1.4	10.4	30.4	60.4
	100	0.5	0.6	1.5	3.5	6.5
	250	0.5	0.6	0.9	1.7	2.9
	500	0.5	0.6	0.8	1.2	1.8

* Values will vary slightly depending on the operating conditions.

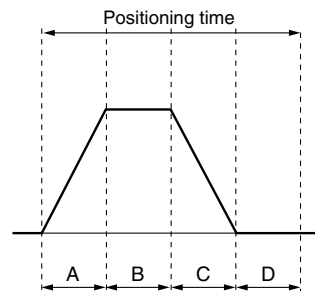

Maximum acceleration: 3000 mm/s²

Standard Motor Vertical Mount Series LJ1H20

Motor Output
100 W

High Rigidity
Direct Acting
Guide

Rolled Ball Screw
∅15 mm/5 mm lead

How to Order

LJ1H20 S2 NF - 300 K - F R 2 A1

Motor type

S2	AC servo motor (Incremental encoder) 100 W
S6	AC servo motor (Absolute encoder) 100 W

Stroke (mm)
Refer to the standard stroke.

Cable entry direction

F	Axial
R	Right
L	Left
T	Top
B	Bottom

Cable type

S	Standard cable
R	Robotic cable (flexible cable)

Cable length

2	2 m
5	5 m
A	10 m

IO connector

Nil	None
H	With IO connector

Auto switch

Nil	Without switch
1	NPN, A contact 1pc.
2	NPN, B contact 2pcs.
3	NPN, A contact 1pc., B contact 2pcs.
4	PNP, A contact 1pc.
5	PNP, B contact 2pcs.
6	PNP, A contact 1pc., B contact 2pcs.

Driver type

Nil	Without driver
A1	Pulse input type (Incremental encoder) 100 V
A2	Pulse input type (Incremental encoder) 200 V
B1	Pulse input type (Absolute encoder) 100 V
B2	Pulse input type (Absolute encoder) 200 V

Cable entry direction

Specifications

Standard stroke (mm)		100	200	300	400	500	600
Performance	Body weight (kg)	8.0	9.2	10.4	11.5	12.9	14.0
	Operating temperature range (°C)	5 to 40 (No condensation)					
	Work load (kg)	15					
	Maximum speed (mm/s)	250					
	Positioning repeatability (mm)	±0.05					
Main parts	Motor	AC servo motor (100 W) with lock					
	Encoder	Incremental system/Absolute type					
	Lead screw	Rolled ball screw ∅15 mm, 5 mm lead					
	Guide	High rigidity direct acting guide					
	Motor/Screw connection	With coupling					
Driver	Model	LECS□□-□ (Refer to page 97 for details.)					

Allowable Moment (N·m)

Allowable static moment

Pitching	71
Yawing	75

m : Transfer load (kg)
a : Work piece acceleration (mm/s²)
Me : Dynamic moment
L : Overhang to work piece center of gravity (mm)

Allowable dynamic moment

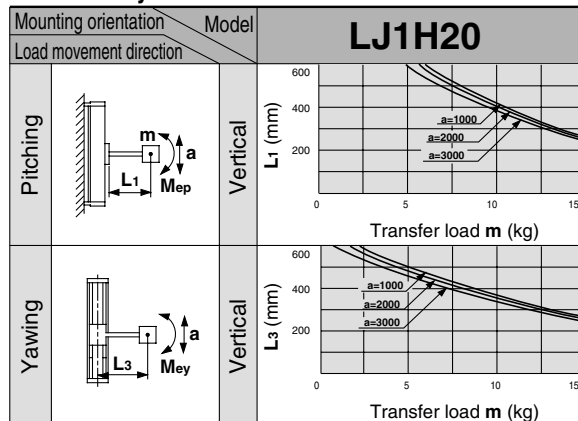

Refer to page 45 for deflection data.

Note) When using this product, the regeneration option may be required.

Investigation of the regeneration option

Depending on the conditions (speed, addition-subtraction speed, down time, load, etc.), the regeneration option may be required. The results of consideration in each case of maximum load or half load for the product specification are below. Please consult SMC when considering the necessity of the regeneration option.

Maximum load

Driver type	Regeneration option model
A1	LEC-MR-RB-032
A2	LEC-MR-RB-032
B1	LEC-MR-RB-032
B2	LEC-MR-RB-032

Half load

Driver type	Regeneration option model
A1	LEC-MR-RB-032
A2	LEC-MR-RB-032
B1	LEC-MR-RB-032
B2	LEC-MR-RB-032

Series LJ1H20

Dimensions/LJ1H20□NF

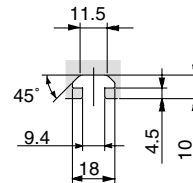
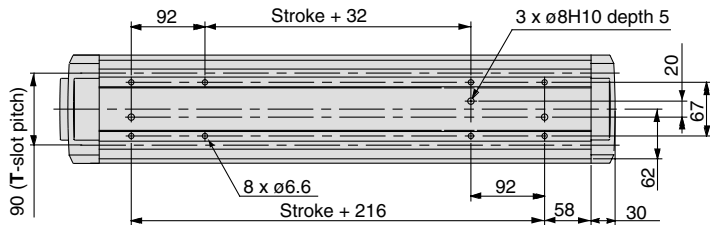
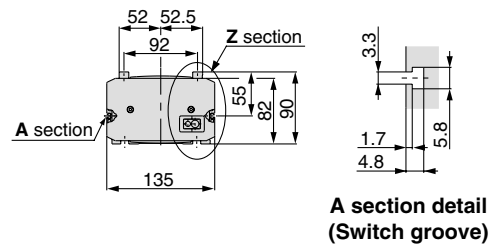
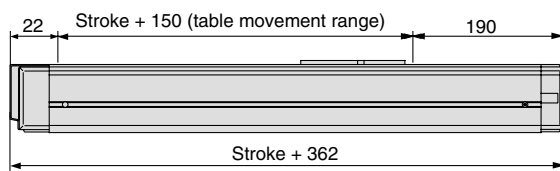
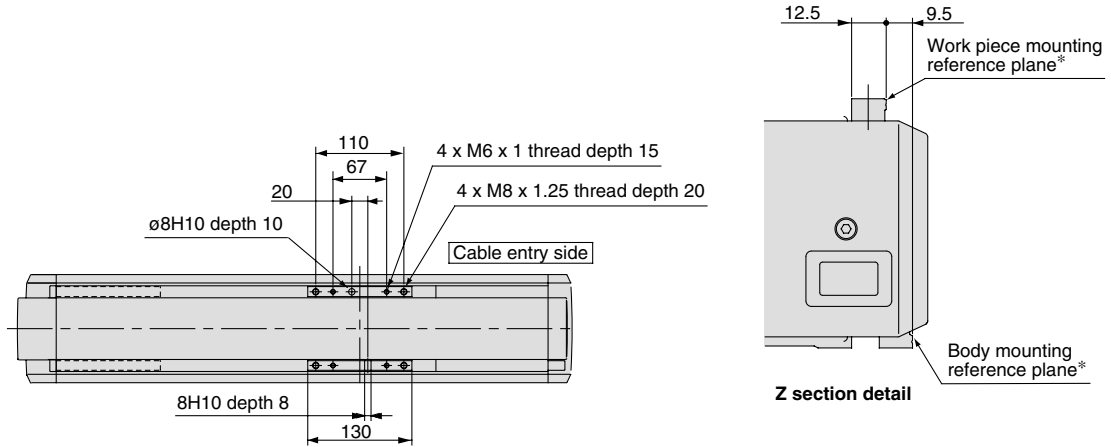

T-slot dimensions

* The body mounting reference plane and work piece mounting reference plane should be used as standards when mounting onto equipment. Refer to pages starting with 42 for mounting.

Positioning Time Guide

		Positioning time (sec.)				
Positioning distance (mm)		1	10	100	300	600
Speed (mm/s)	10	0.5	1.4	10.4	30.4	60.4
	100	0.5	0.6	1.5	3.5	6.5
	125	0.5	0.6	1.3	2.9	5.3
	250	0.5	0.6	0.9	1.7	2.9

* Values will vary slightly depending on the operating conditions.

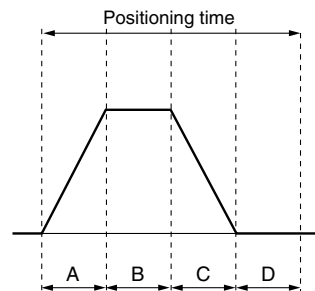

A: Acceleration time
B: Constant velocity time
C: Deceleration time
D: Resting time (0.4 sec.)
Maximum acceleration: 3000 mm/s²

Standard Motor Vertical Mount Series LJ1H20

Motor Output
100 W

High Rigidity
Direct Acting
Guide

Rolled Ball Screw
∅15 mm/10 mm lead

How to Order

LJ1H20 S2 NA - 300 K - F R 2 A1 - [] - []

Motor type

S2	AC servo motor (Incremental encoder) 100 W
S6	AC servo motor (Absolute encoder) 100 W

Stroke (mm)
Refer to the standard stroke.

Cable entry direction

F	Axial
R	Right
L	Left
T	Top
B	Bottom

Cable type

S	Standard cable
R	Robotic cable (flexible cable)

Cable length

2	2 m
5	5 m
A	10 m

IO connector

Nil	None
H	With IO connector

Auto switch

Nil	Without switch
1	NPN, A contact 1pc.
2	NPN, B contact 2pcs.
3	NPN, A contact 1pc., B contact 2pcs.
4	PNP, A contact 1pc.
5	PNP, B contact 2pcs.
6	PNP, A contact 1pc., B contact 2pcs.

Driver type

Nil	Without driver
A1	Pulse input type (Incremental encoder) 100 V
A2	Pulse input type (Incremental encoder) 200 V
B1	Pulse input type (Absolute encoder) 100 V
B2	Pulse input type (Absolute encoder) 200 V

Specifications

Standard stroke (mm)		100	200	300	400	500	600
Performance	Body weight (kg)	8.0	9.2	10.4	11.5	12.9	14.0
	Operating temperature range (°C)	5 to 40 (No condensation)					
	Work load (kg)	8					
	Maximum speed (mm/s)	500					
	Positioning repeatability (mm)	±0.05					
Main parts	Motor	AC servo motor (100W) with lock					
	Encoder	Incremental system/Absolute type					
	Lead screw	Rolled ball screw ∅15 mm, 10 mm lead					
	Guide	High rigidity direct acting guide					
	Motor/Screw connection	With coupling					
Driver	Model	LECS□□-□ (Refer to page 97 for details.)					

Allowable Moment (N·m)

Allowable static moment

Pitching	71
Yawing	75

m : Transfer load (kg)
a : Work piece acceleration (mm/s²)
Me : Dynamic moment
L : Overhang to work piece center of gravity (mm)

Allowable dynamic moment

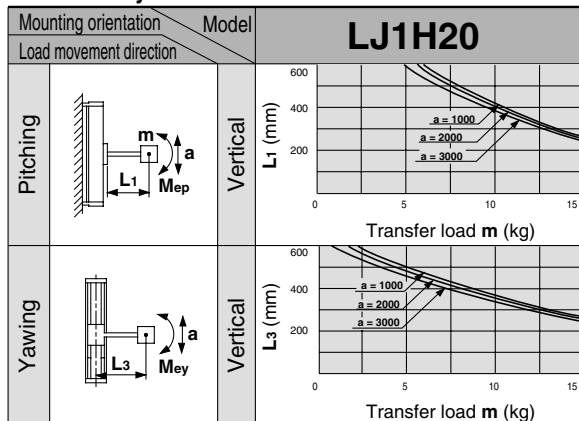

Refer to page 45 for deflection data.

Note) When using this product, the regeneration option may be required.

Investigation of the regeneration option

Depending on the conditions (speed, addition-subtraction speed, down time, load, etc.), the regeneration option may be required. The results of consideration in each case of maximum load or half load for the product specification are below. Please consult SMC when considering the necessity of the regeneration option.

Maximum load

Driver type	Regeneration option model
A1	LEC-MR-RB-032
A2	LEC-MR-RB-032
B1	LEC-MR-RB-032
B2	LEC-MR-RB-032

Half load

Driver type	Regeneration option model
A1	LEC-MR-RB-032
A2	LEC-MR-RB-032
B1	LEC-MR-RB-032
B2	LEC-MR-RB-032

Series LJ1H20

Dimensions/LJ1H20□NA

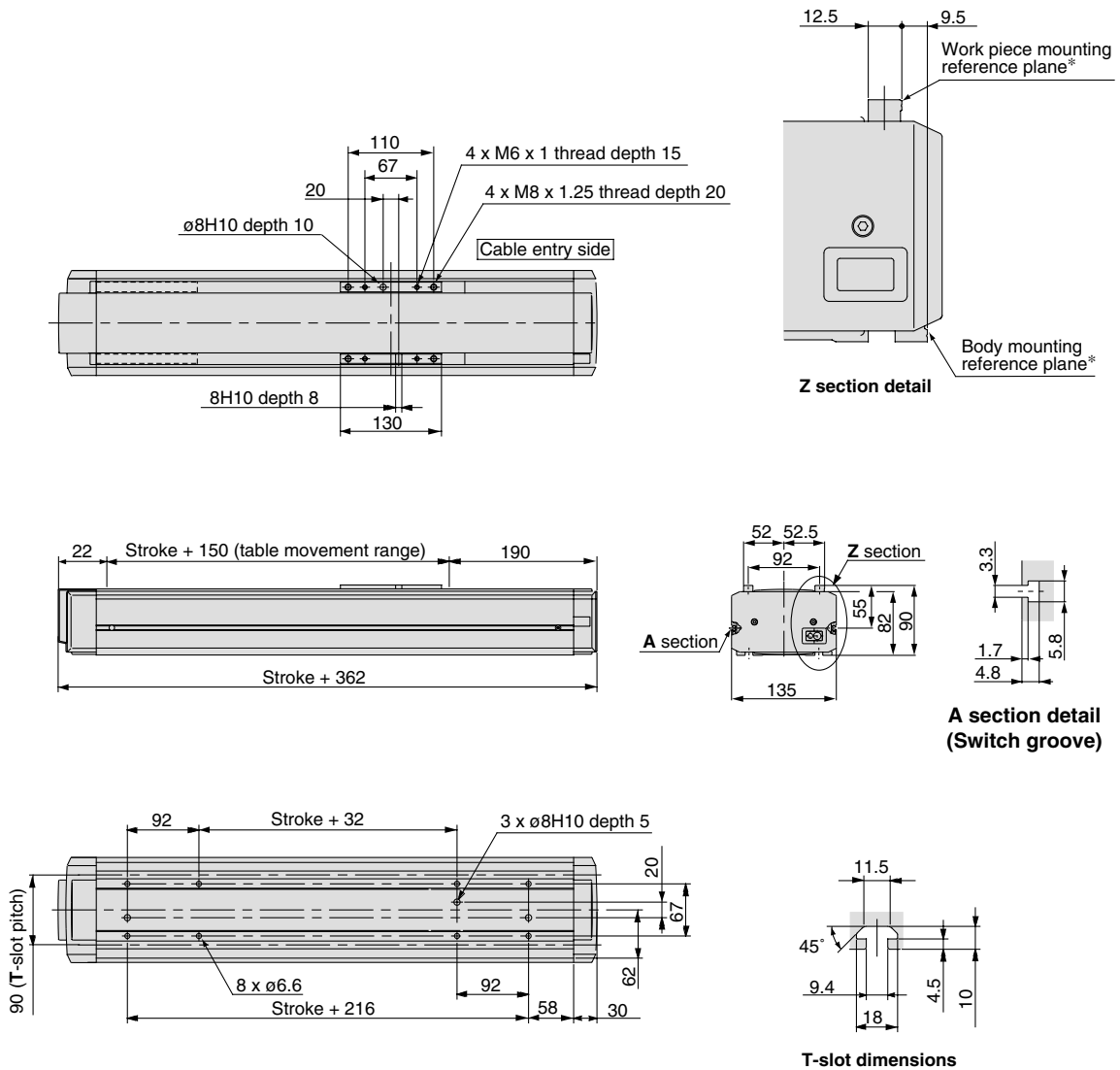

* The body mounting reference plane and work piece mounting reference plane should be used as standards when mounting onto equipment. Refer to pages starting with 42 for mounting.

Positioning Time Guide

		Positioning time (sec.)				
Positioning distance (mm)		1	10	100	300	600
Speed (mm/s)	10	0.5	1.4	10.4	30.4	60.4
	100	0.5	0.6	1.5	3.5	6.5
	250	0.5	0.6	0.9	1.7	2.9
	500	0.5	0.6	0.8	1.2	1.8

* Values will vary slightly depending on the operating conditions.

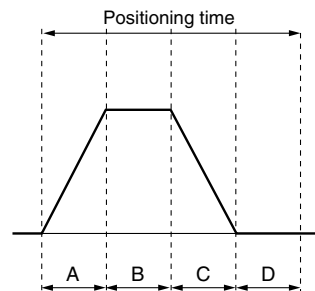

A: Acceleration time
 B: Constant velocity time
 C: Deceleration time
 D: Resting time (0.4 sec.)
 Maximum acceleration: 3000 mm/s²

Standard Motor Vertical Mount Series LJ1H30

Motor Output
200 W

High Rigidity
Direct Acting
Guide

Ground Ball Screw
∅20 mm/10 mm lead

How to Order

LJ1H30 S3 PA - 300 K - F R 2 A1 - [] - []

Motor type

S3	AC servo motor (Incremental encoder) 200 W
S7	AC servo motor (Absolute encoder) 200 W

Stroke (mm)
Refer to the standard stroke.

Cable entry direction

F	Axial
R	Right
L	Left
T	Top
B	Bottom

Cable type

S	Standard cable
R	Robotic cable (flexible cable)

Cable length

2	2 m
5	5 m
A	10 m

IO connector

Nil	None
H	With IO connector

Auto switch

Nil	Without switch
1	NPN, A contact 1pc.
2	NPN, B contact 2pcs.
3	NPN, A contact 1pc., B contact 2pcs.
4	PNP, A contact 1pc.
5	PNP, B contact 2pcs.
6	PNP, A contact 1pc., B contact 2pcs.

Driver type

Nil	Without driver
A1	Pulse input type (Incremental encoder) 100 V
A2	Pulse input type (Incremental encoder) 200 V
B1	Pulse input type (Absolute encoder) 100 V
B2	Pulse input type (Absolute encoder) 200 V

Specifications

Standard stroke (mm)		200	300	400	500	600
Performance	Body weight (kg)	16.3	18.3	20.3	22.3	24.3
	Operating temperature range (°C)	5 to 40 (No condensation)				
	Work load (kg)	20				
	Maximum speed (mm/s)	500				
	Positioning repeatability (mm)	±0.02				
Main parts	Motor	AC servo motor (200 W) with lock				
	Encoder	Incremental system/Absolute type				
	Lead screw	Ground ball screw ∅20 mm, 10 mm lead				
	Guide	High rigidity direct acting guide				
	Motor/Screw connection	With coupling				
Driver	Model	LECS□□-□ (Refer to page 97 for details.)				

Allowable Moment (N·m)

Allowable static moment

Pitching	117
Yawing	123

m : Transfer load (kg)
a : Work piece acceleration (mm/s²)
Me : Dynamic moment
L : Overhang to work piece center of gravity (mm)

Allowable dynamic moment

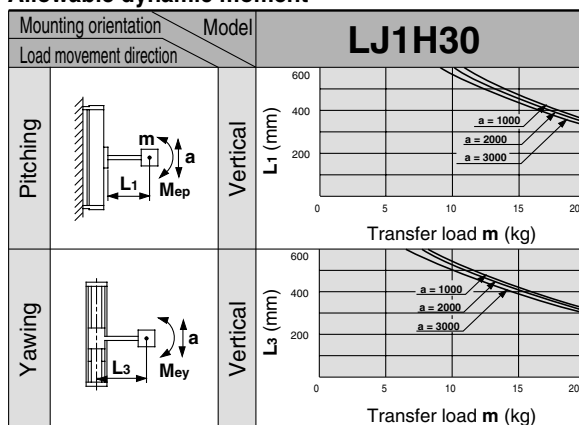

Refer to page 45 for deflection data.

Note) When using this product, the regeneration option may be required.

Investigation of the regeneration option

Depending on the conditions (speed, addition-subtraction speed, down time, load, etc.), the regeneration option may be required. The results of consideration in each case of maximum load or half load for the product specification are below. Please consult SMC when considering the necessity of the regeneration option.

Maximum load

Driver type	Regeneration option model
A1	LEC-MR-RB-12
A2	LEC-MR-RB-12
B1	LEC-MR-RB-12
B2	LEC-MR-RB-12

Half load

Driver type	Regeneration option model
A1	LEC-MR-RB-032
A2	LEC-MR-RB-032
B1	LEC-MR-RB-032
B2	LEC-MR-RB-032

Series LJ1H30

Dimensions/LJ1H30□PA

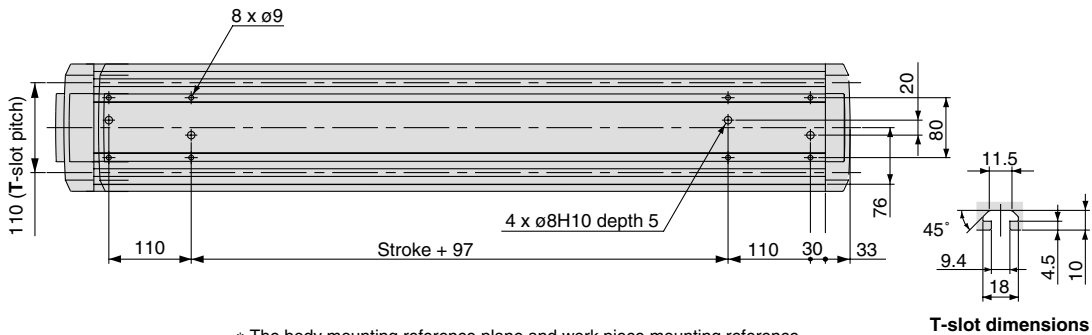
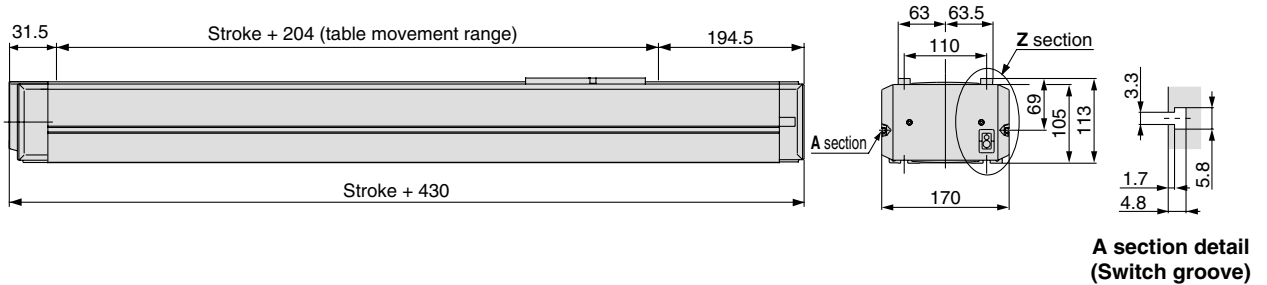
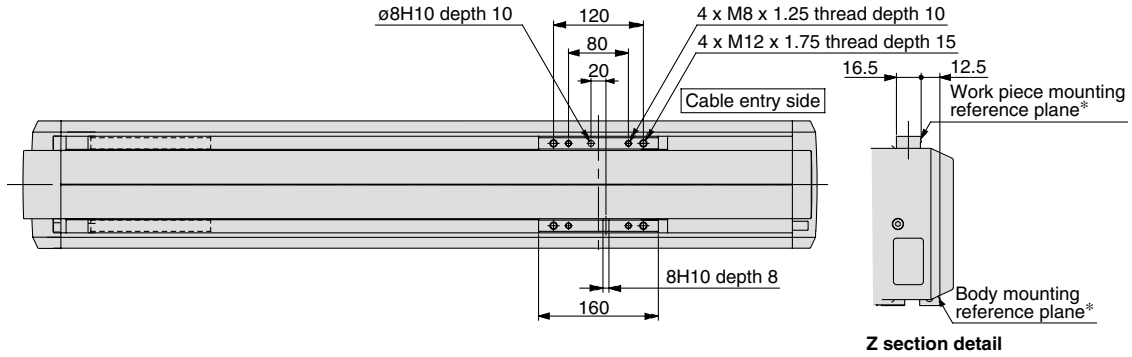

* The body mounting reference plane and work piece mounting reference plane should be used as standards when mounting onto equipment. Refer to pages starting with 42 for mounting.

Positioning Time Guide

		Positioning time (sec.)				
Positioning distance (mm)		1	10	100	300	600
Speed (mm/s)	10	1.1	2.0	11.0	31.0	61.0
	100	1.1	1.2	2.1	4.1	7.1
	250	1.1	1.2	1.5	2.3	3.5
	500	1.1	1.2	1.4	1.8	2.4

* Values will vary slightly depending on the operating conditions.

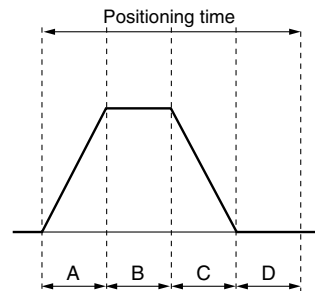

A: Acceleration time
 B: Constant velocity time
 C: Deceleration time
 D: Resting time (1.0 sec.)
 Maximum acceleration: 3000 mm/s²

Standard Motor Vertical Mount Series LJ1H30

Motor Output
200 W

High Rigidity
Direct Acting
Guide

Rolled Ball Screw
∅20 mm/10 mm lead

How to Order

LJ1H30 S3 NA - 300 K - F R 2 A1 - [] - []

Motor type

S3	AC servo motor (Incremental encoder) 200 W
S7	AC servo motor (Absolute encoder) 200 W

Stroke (mm)
Refer to the standard stroke.

Cable type

S	Standard cable
R	Robotic cable (flexible cable)

Cable length

2	2 m
5	5 m
A	10 m

Cable entry direction

F	Axial
R	Right
L	Left
T	Top
B	Bottom

IO connector

Nil	None
H	With IO connector

Auto switch

Nil	Without switch
1	NPN, A contact 1pc.
2	NPN, B contact 2pcs.
3	NPN, A contact 1pc., B contact 2pcs.
4	PNP, A contact 1pc.
5	PNP, B contact 2pcs.
6	PNP, A contact 1pc., B contact 2pcs.

Driver type

Nil	Without driver
A1	Pulse input type (Incremental encoder) 100 V
A2	Pulse input type (Incremental encoder) 200 V
B1	Pulse input type (Absolute encoder) 100 V
B2	Pulse input type (Absolute encoder) 200 V

Specifications

	Standard stroke (mm)	200	300	400	500	600
Performance	Body weight (kg)	16.3	18.3	20.3	22.3	24.3
	Operating temperature range (°C)	5 to 40 (No condensation)				
	Work load (kg)	20				
	Maximum speed (mm/s)	500				
	Positioning repeatability (mm)	±0.05				
Main parts	Motor	AC servo motor (200 W) with lock				
	Encoder	Incremental system/Absolute type				
	Lead screw	Rolled ball screw ∅20 mm, 10 mm lead				
	Guide	High rigidity direct acting guide				
	Motor/Screw connection	With coupling				
Driver	Model	LECS□□-□ (Refer to page 97 for details.)				

Allowable Moment (N·m)

Allowable static moment

Pitching	117
Yawing	123

m : Transfer load (kg)
a : Work piece acceleration (mm/s²)
Me : Dynamic moment
L : Overhang to work piece center of gravity (mm)

Allowable dynamic moment

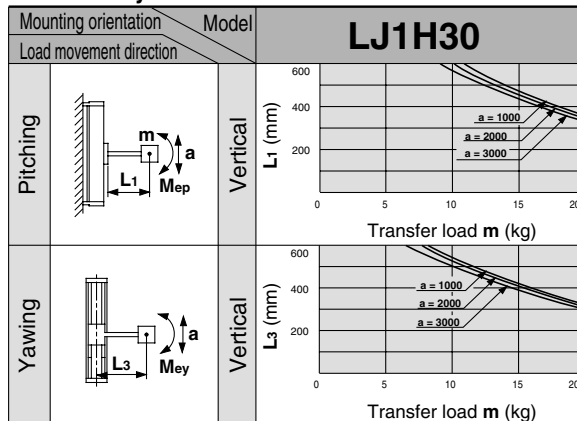

Refer to page 45 for deflection data.

Note) When using this product, the regeneration option may be required.

Investigation of the regeneration option

Depending on the conditions (speed, addition-subtraction speed, down time, load, etc.), the regeneration option may be required. The results of consideration in each case of maximum load or half load for the product specification are below. Please consult SMC when considering the necessity of the regeneration option.

Maximum load

Driver type	Regeneration option model
A1	LEC-MR-RB-12
A2	LEC-MR-RB-12
B1	LEC-MR-RB-12
B2	LEC-MR-RB-12

Half load

Driver type	Regeneration option model
A1	LEC-MR-RB-032
A2	LEC-MR-RB-032
B1	LEC-MR-RB-032
B2	LEC-MR-RB-032

Series LJ1H30

Dimensions/LJ1H30□NA

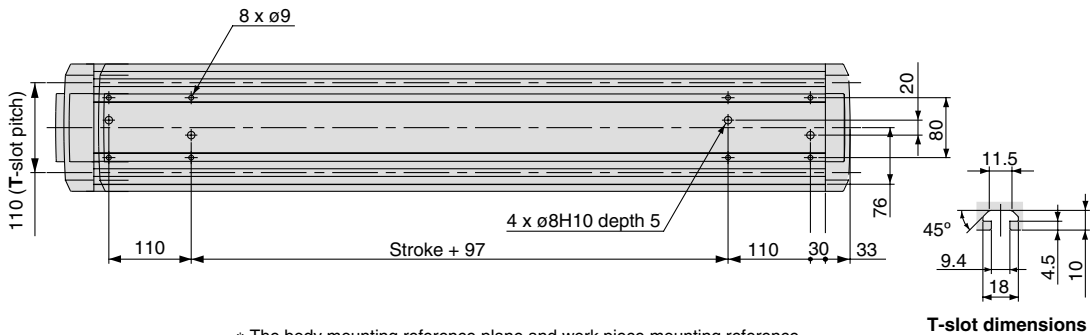
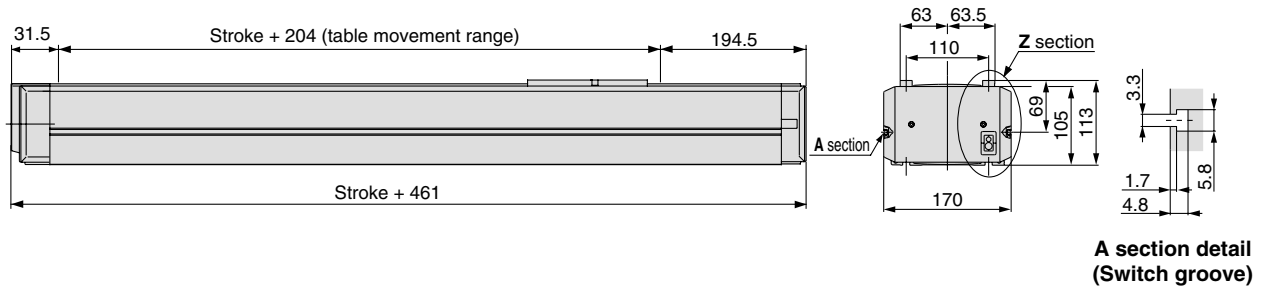
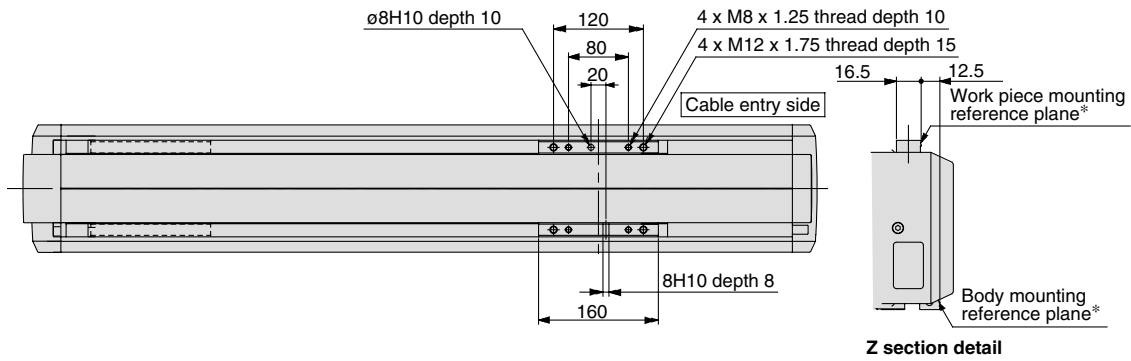

* The body mounting reference plane and work piece mounting reference plane should be used as standards when mounting onto equipment. Refer to pages starting with 42 for mounting.

Positioning Time Guide

		Positioning time (sec.)				
		1	10	100	300	600
Speed (mm/s)	10	0.5	2.0	11.0	31.0	61.0
	100	1.1	1.2	2.1	4.1	7.1
	250	1.1	1.2	1.5	2.3	3.5
	500	1.1	1.2	1.4	1.8	2.4

* Values will vary slightly depending on the operating conditions.

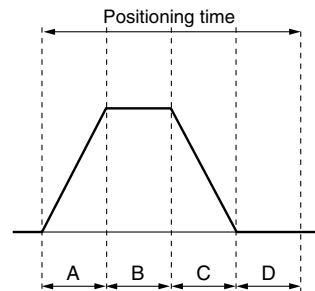

A: Acceleration time
 B: Constant velocity time
 C: Deceleration time
 D: Resting time (1.0 sec.)
 Maximum acceleration: 3000 mm/s²

Series LJ1 Options

T-nuts for Mounting Electric Actuators

Use T-nuts for T-slot mounting of an actuator. When mounting by means of T-nuts alone, the quantity of nuts indicated below should be used as a minimum.

Model **LJ1-T8** (Mass 8.4 g)

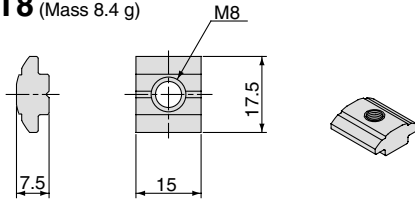

T-nut quantity

Model	Quantity
LJ1H10	200 mm stroke or less: 6 pcs.
	300 mm stroke or more: 8 pcs.
LJ1H20	8 pcs.
LJ1H30	8 pcs.

* Only series LJ1H10 has the T-nuts built into the body.

Series LJ1H Construction

Construction

LJ1H10

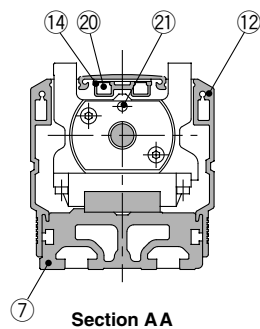
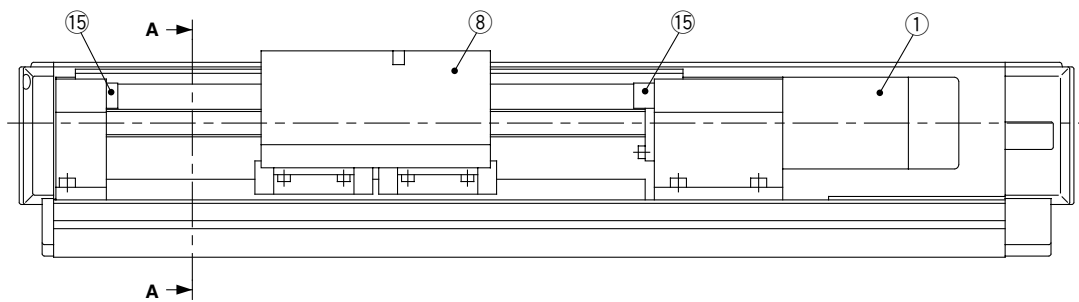
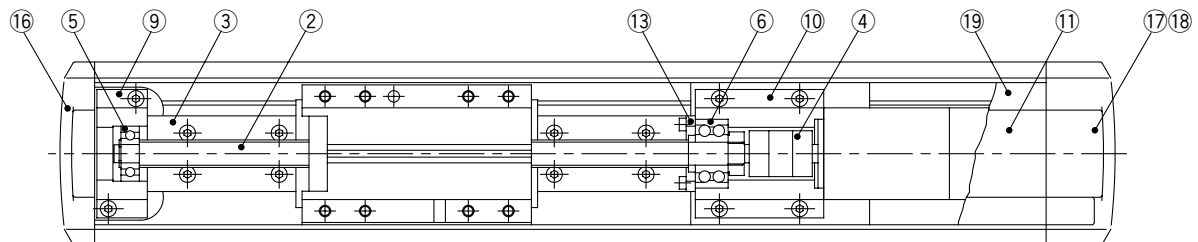

Parts list

No.	Description	Material	Note
1	AC servo motor	—	100 W
2	Lead screw	—	Ball screw
3	High rigidity direct acting guide	—	
4	Coupling	—	
5	Bearing R	—	
6	Bearing F	—	
7	Body A	Aluminum alloy	
8	Table	Aluminum alloy	
9	Housing A	Aluminum alloy	
10	Housing B	Aluminum alloy	
11	Top cover	Aluminum alloy	

No.	Description	Material	Note
12	Side cover	Aluminum alloy	
13	Bearing retainer	Aluminum alloy	
14	Sensor rail	Aluminum alloy	
15	Bumper	IIR	
16	End cover A	PC	
17	End cover B	PC	
18	Inner cover	PC	
19	Motor cover	PC	
20	Auto switch	—	
21	Magnet	—	

Construction

LJ1H20

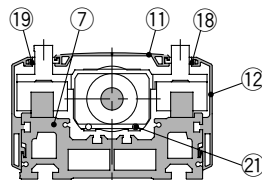
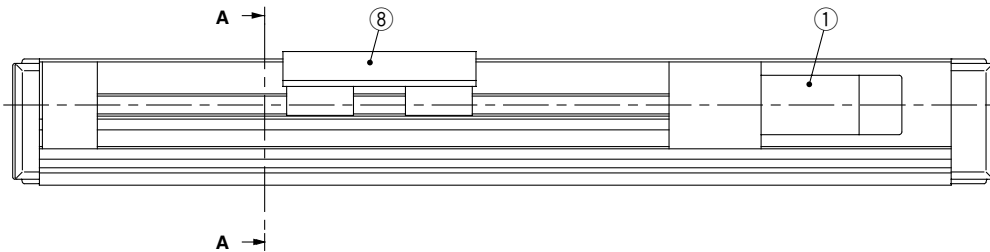
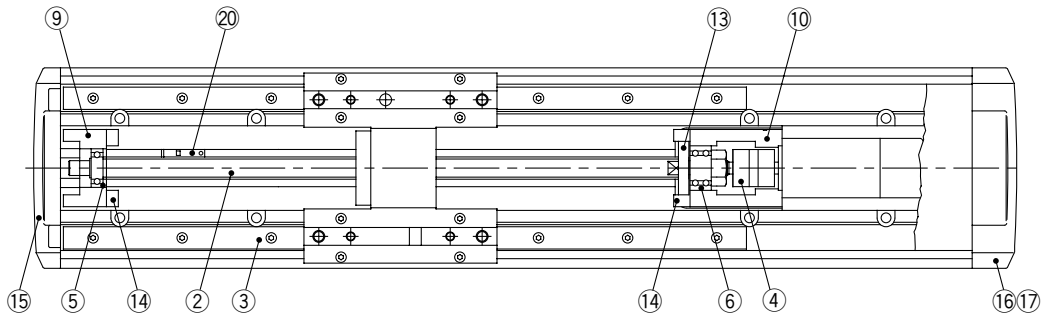

Section AA

Parts list

No.	Description	Material	Note
1	AC servo motor	—	100 W
2	Lead screw	—	Ball screw
3	High rigidity direct acting guide	—	
4	Coupling	—	
5	Bearing R	—	
6	Bearing F	—	
7	Body A	Aluminum alloy	
8	Table	Aluminum alloy	
9	Housing A	Aluminum alloy	
10	Housing B	Aluminum alloy	
11	Top cover	Aluminum alloy	

No.	Description	Material	Note
12	Side cover	Aluminum alloy	
13	Bearing retainer	Aluminum alloy	
14	Bumper	IIR	
15	End cover A	PC	
16	End cover B	PC	
17	Inner cover	PC	
18	Motor cover R	PC	
19	Motor cover L	PC	
20	Auto switch	—	
21	Magnet	—	

Series LJ1H

Construction

LJ1H30

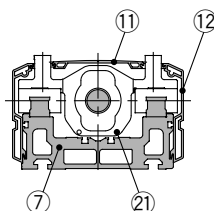
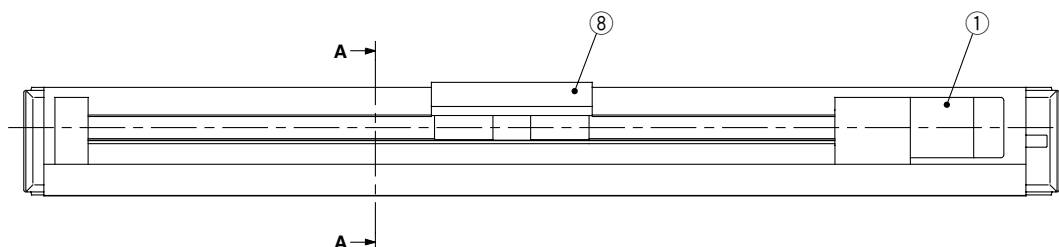
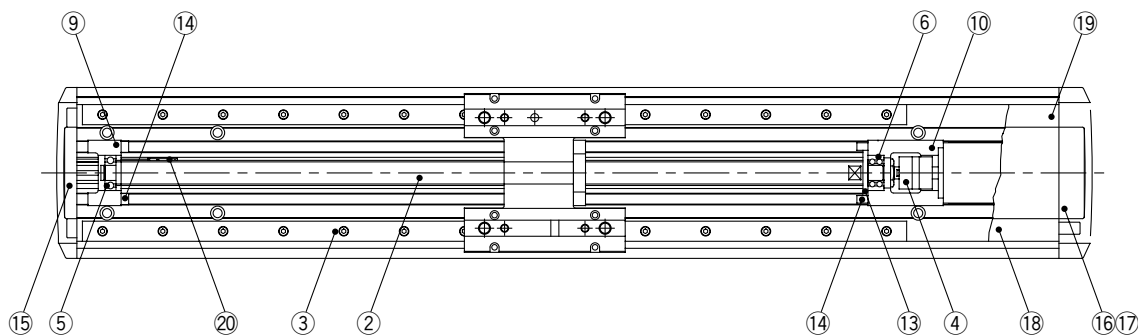

Section AA

Parts list

No.	Description	Material	Note
1	AC servo motor	—	200 W
2	Lead screw	—	Ball screw
3	High rigidity direct acting guide	—	
4	Coupling	—	
5	Bearing R	—	
6	Bearing F	—	
7	Body A	Aluminum alloy	
8	Table	Aluminum alloy	
9	Housing A	Aluminum alloy	
10	Housing B	Aluminum alloy	
11	Top cover	Aluminum alloy	

No.	Description	Material	Note
12	Side cover	Aluminum alloy	
13	Bearing retainer	Carbon steel	Electroless nickel plated
14	Bumper	IIR	
15	End cover A	PC	
16	End cover B	PC	
17	Inner cover	PC	
18	Motor cover A	PC	
19	Motor cover B	PC	
20	Auto switch	—	
21	Magnet	—	

Series LJ1 Mounting

T-slot Bottom Mount

LJ1H10

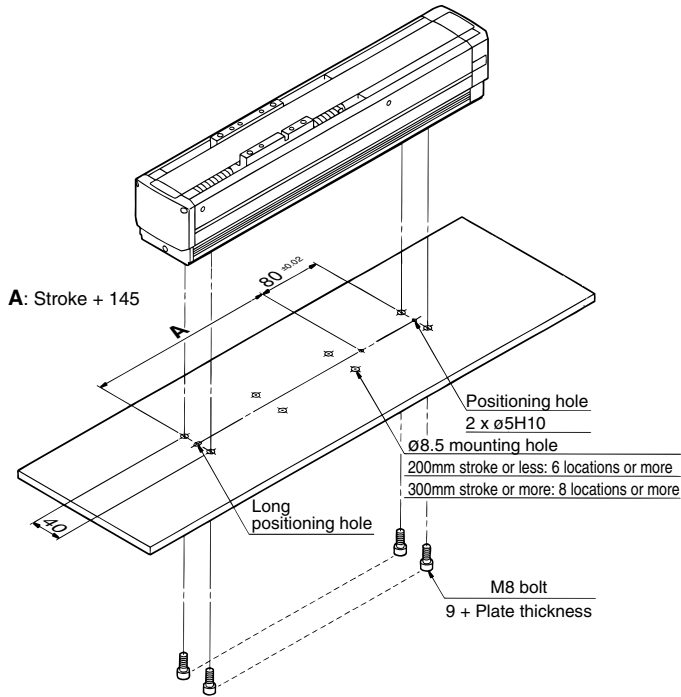

LJ1H20

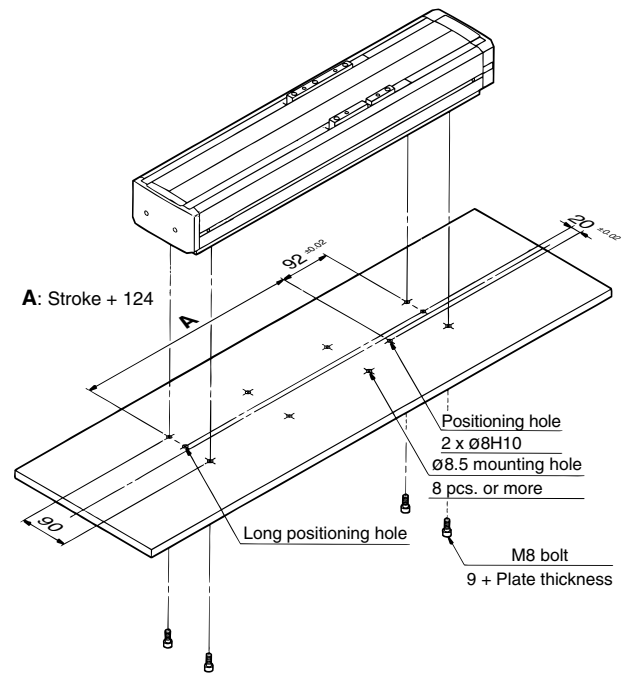

LJ1H30

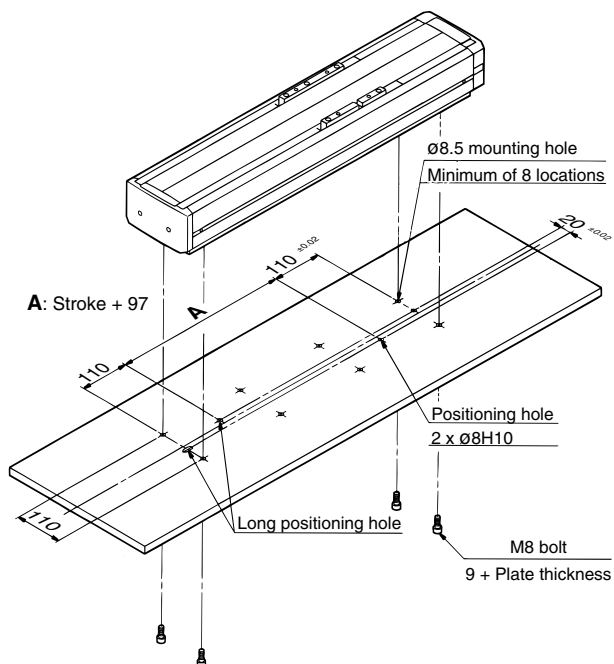

Note 1) Although T-nuts (LJ1-T8) for mounting are included with the body for LJ1H10, they are optional for other models. (See page 38.)

Note 2) To insert the T-nuts, remove the covers at both ends of the body and insert them into the T-slots.

Note 3) When positioning of the body is required, also perform pin hole machining.

Top Mount

LJ1H20

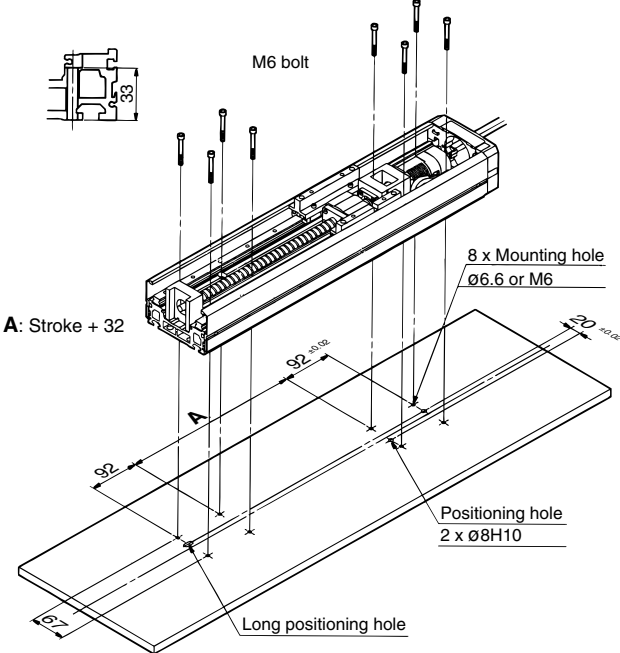

LJ1H30

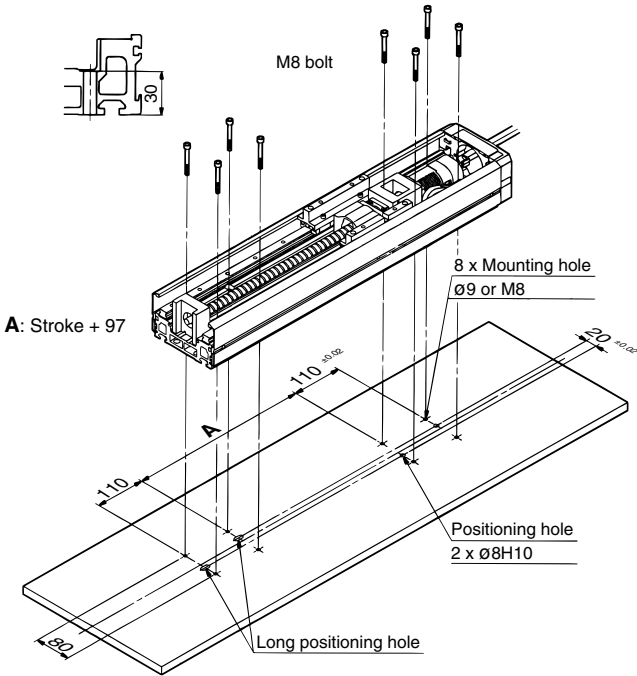

Series LJ1

Top Mount (Using T-slots on the Mounting Frame)

LJ1H20

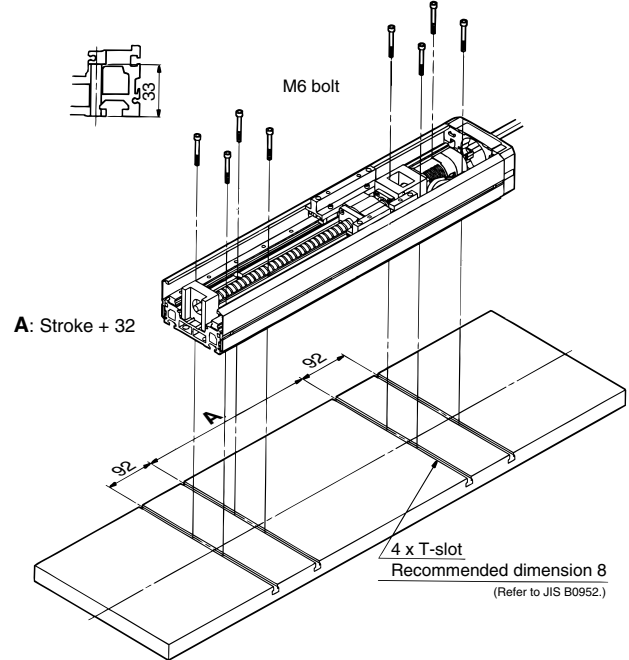
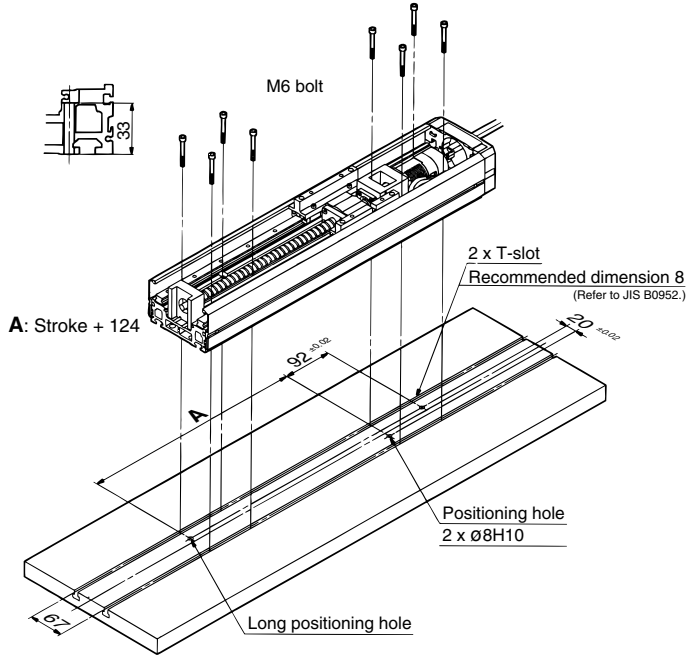

LJ1H30

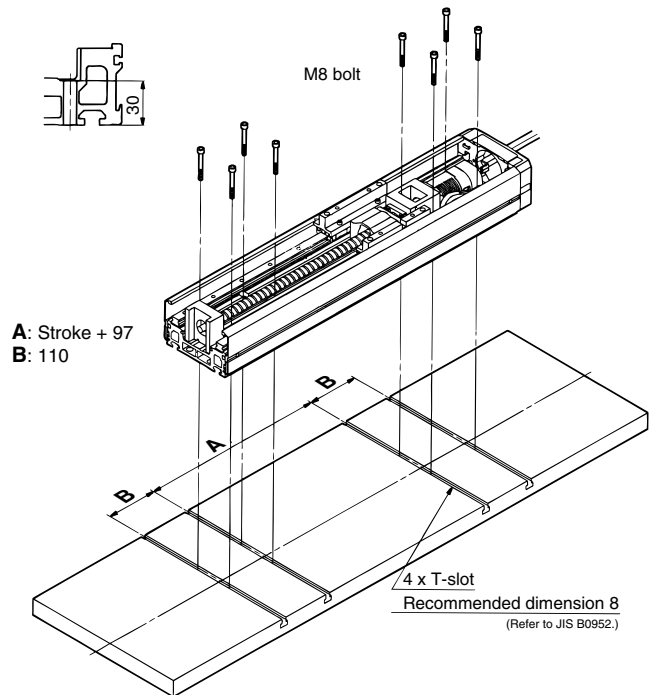
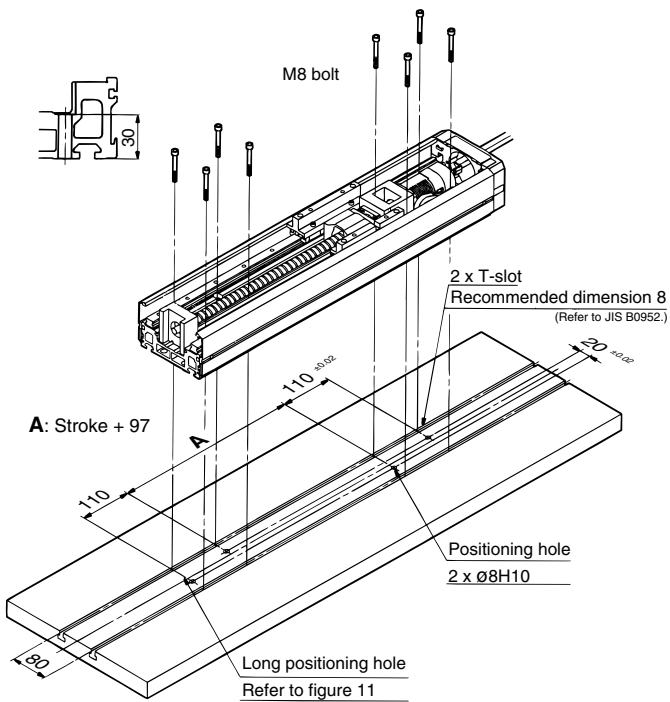

Series LJ1 Deflection Data

Deflection Data/LJ1H

* Calculated values based on the body's geometric moment of inertia.

The load and the amount of deflection at load point W are shown in the graphs below for each series.

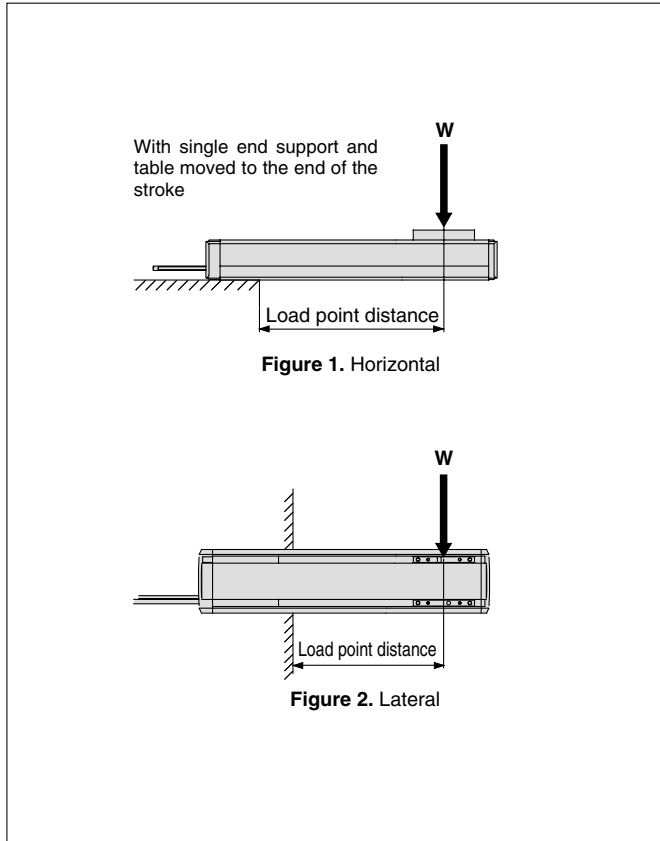

LJ1H10

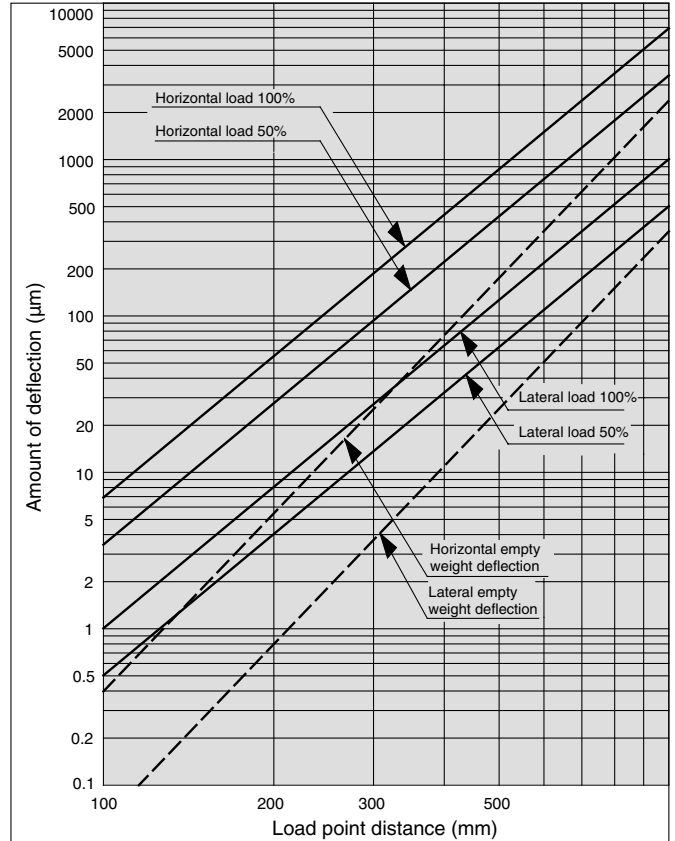

LJ1H20

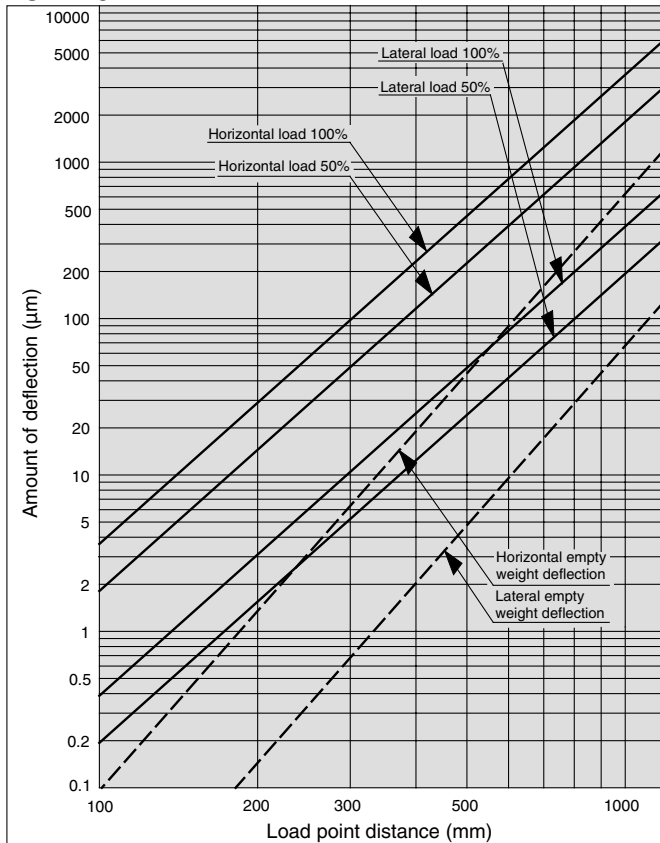

LJ1H30

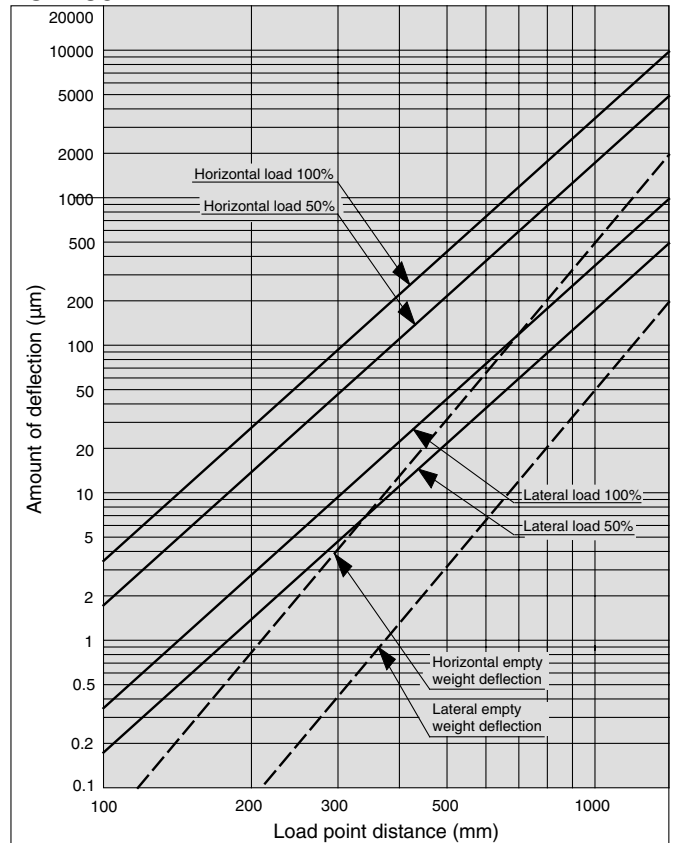



Series LECSA

Series LECSB

AC Servo Motor Driver (Pulse Input Type)

Incremental Type

Series **LECSA**

Absolute Type

Series **LECSB**

Compatible Actuator	Page
Single Axis Electric Actuator Series LJ1H	Page 1
Low Profile Single Axis Electric Actuator Series LG1H	Page 47
Electric Actuator with Integrated Guide Series LTF	Page 59

- Incremental Type/LECSA ————— Page 98
- Absolute Type/LECSB ————— Page 98
- Option ————— Page 104

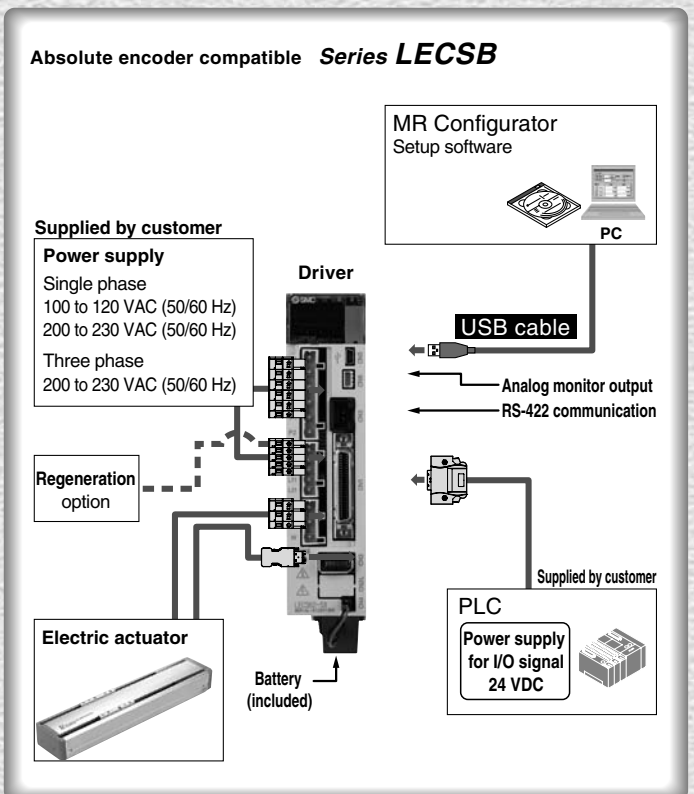
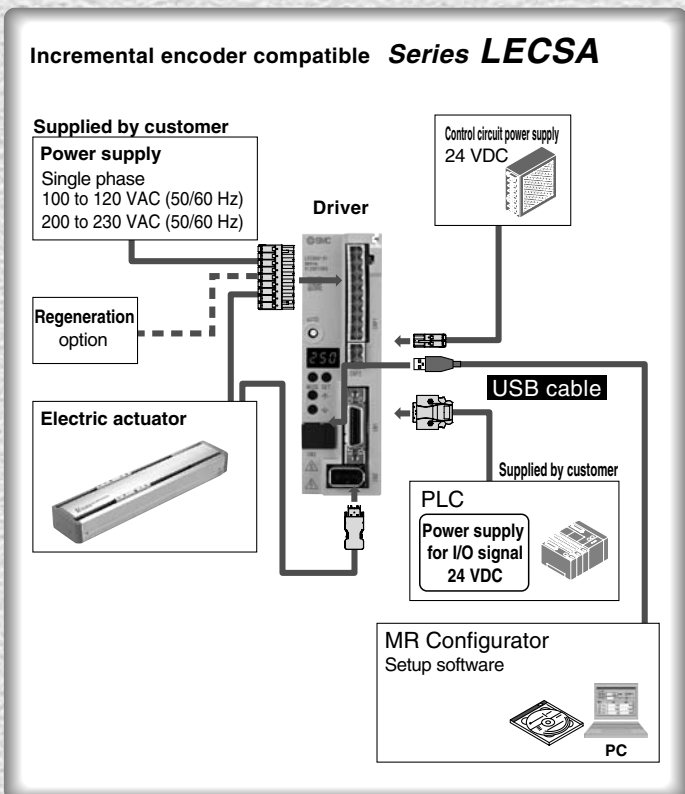

AC Servo Motor Driver (Pulse Input Type)

Incremental Type

Series **LECSA**

Absolute Type

Series **LECSB**



LECSA

LECSB

How to Order

LECS A 1 - S1

Driver type

A	Pulse input type (For incremental encoder)
B	Pulse input type (For absolute encoder)

Motor type

Symbol	Type	Capacity	Encoder
S1	AC servo motor (S2)	100 W	Incremental
S3	AC servo motor (S3)	200 W	
S5	AC servo motor (S6)	100 W	Absolute
S7	AC servo motor (S7)	200 W	

Power supply voltage

1	100 to 120 VAC, 50/60 Hz
2	200 to 230 VAC, 50/60 Hz

Part no. list Select controller type and compatible motor from the combinations in the table below.

Controller part no.	Controller type	Motor type	Power supply voltage
LECSA1-S1	Pulse input type (For incremental encoder)	AC servo motor (S2)	100 to 120 VAC 50/60 Hz
LECSA1-S3		AC servo motor (S3)	
LECSA2-S1		AC servo motor (S2)	
LECSA2-S3	Pulse input type (For absolute encoder)	AC servo motor (S3)	200 to 230 VAC 50/60 Hz
LECSB1-S5		AC servo motor (S6)	
LECSB1-S7		AC servo motor (S7)	
LECSB2-S5		AC servo motor (S6)	
LECSB2-S7	AC servo motor (S7)	50/60 Hz	

Dimensions

LECSA □

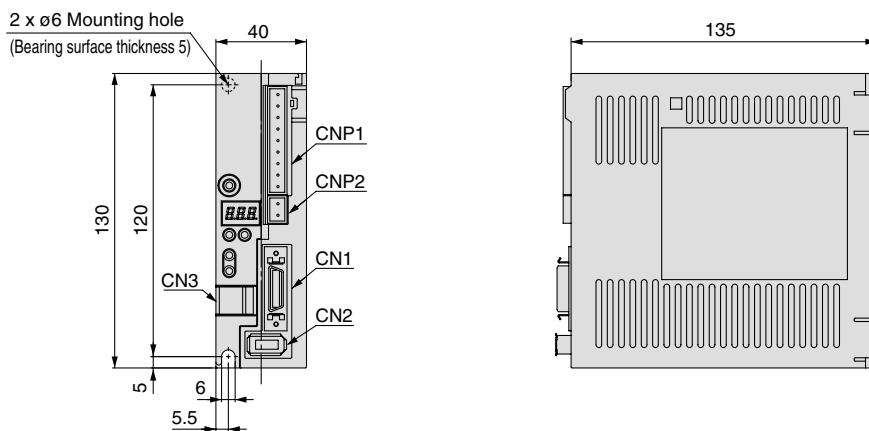

LECSB □

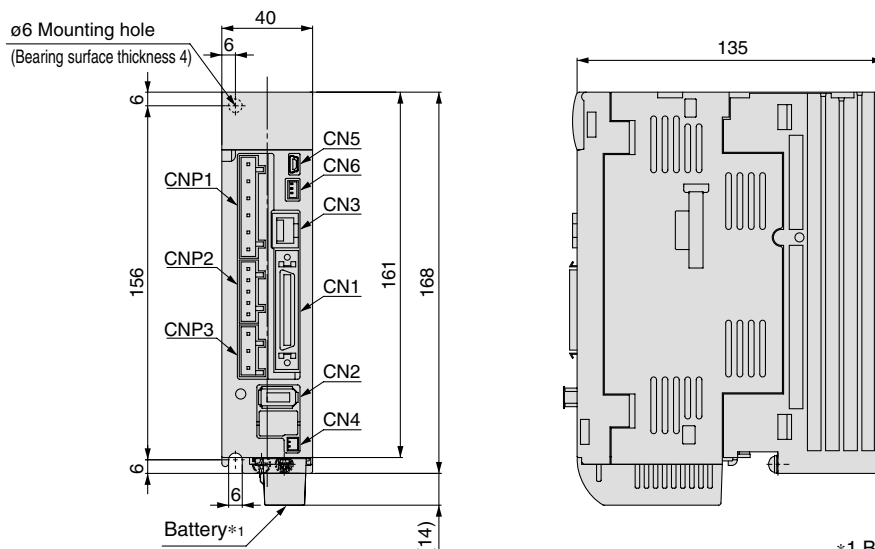

*1 Battery included.

Incremental Type **Series LECSA**
Absolute Type **Series LECSB**

Specifications

Model		LECSA1-S1	LECSA1-S3	LECSA2-S1	LECSA2-S3
Compatible motor capacity [W]		100	200	100	200
Compatible encoder		Incremental 17-bit encoder (Resolution: 131072 p/rev)			
Main power supply	Power voltage [V]	Single phase 100 to 120 VAC (50/60 Hz)		Single phase 200 to 230 VAC (50/60 Hz)	
	Allowable voltage range [V]	Single phase 85 to 132 VAC		Single phase 170 to 253 VAC	
	Rated voltage [A]	3.0	5.0	1.5	2.4
Control power supply	Control power supply voltage [V]	24 VDC			
	Allowable voltage range for control power supply [V]	21.6 to 26.4 VDC			
	Rated voltage [A]	0.5			
Parallel input		6 inputs			
Parallel output		4 outputs			
Max. input pulse frequency [pps]		1 M (when differential receiver), 200 k (when open collector)			
Function	Positioning completion width setting range [pulse]	0 to ±65535 (Pulse command unit)			
	Error excessive	±3 rotations			
	Torque limit	Parameter setting			
	Communication	USB communication			
Operating temperature range [°C]		0 to 40 (No freezing)			
Operating humidity range [%RH]		90 or less (No condensation)			
Storage temperature range [°C]		-20 to 65 (No freezing)			
Storage humidity range [%RH]		90 or less (No condensation)			
Insulation resistance [MΩ]		Between case and SG: 10 (500 VDC)			
Weight [g]		600			

Model		LECSB1-S5	LECSB1-S7	LECSB2-S5	LECSB2-S7
Compatible motor capacity [W]		100	200	100	200
Compatible encoder		Absolute 18-bit encoder (Resolution: 262144 p/rev)			
Main power supply	Power voltage [V]	Single phase 100 to 120 VAC (50/60 Hz)		Three phase 200 to 230 VAC (50/60 Hz) Single phase 200 to 230 VAC (50/60 Hz)	
	Allowable voltage range [V]	Single phase 85 to 132 VAC		Three phase 170 to 253 VAC Single phase 170 to 253 VAC	
	Rated voltage [A]	3.0	5.0	0.9	1.5
Control power supply	Control power supply voltage [V]	Single phase 100 to 120 VAC (50/60 Hz)		Single phase 200 to 230 VAC (50/60 Hz)	
	Allowable voltage range for control power supply [V]	Single phase 85 to 132 VAC		Single phase 170 to 253 VAC	
	Rated voltage [A]	0.4		0.2	
Parallel input		10 inputs			
Parallel output		6 outputs			
Max. input pulse frequency [pps]		1 M (when differential receiver), 200 k (when open collector)			
Function	Positioning completion width setting range [pulse]	0 to ±10000 (Pulse command unit)			
	Error excessive	±3 rotations			
	Torque limit	Parameter setup or external analog input setup (0 to 10 VDC)			
	Communication	USB communication, RS422 communication*1			
Operating temperature range [°C]		0 to 40 (No freezing)			
Operating humidity range [%RH]		90 or less (No condensation)			
Storage temperature range [°C]		-20 to 65 (No freezing)			
Storage humidity range [%RH]		90 or less (No condensation)			
Insulation resistance [MΩ]		Between case and SG: 10 (500 VDC)			
Weight [g]		800			

*1 USB communication and RS422 communication cannot be performed at the same time.

Series LECSA

Series LECSB

Power Supply Wiring Example: LECSA

LECSA□-□

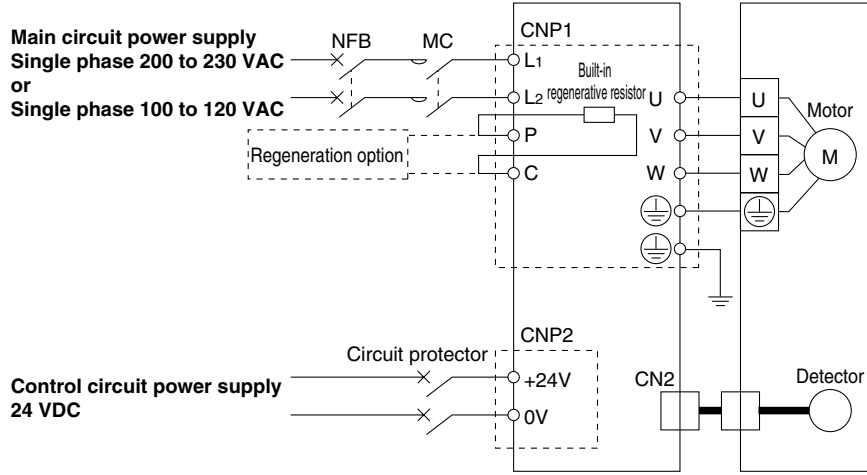

Main Circuit Power Supply Connector: CNP1 *Accessory

Terminal name	Function	Function details
	Protective earth (PE)	Should be grounded via servo motor's earth terminal and control panel's protective earth (PE) after connecting them.
L1	Main circuit power supply	Connect the main circuit power supply. LECSA1: Single phase 100 to 120 VAC, 50/60 Hz LECSA2: Single phase 200 to 230 VAC, 50/60 Hz
L2		
P	Regeneration option	Terminal to connect regeneration option LECSA□-S1: No need for connection LECSA□-S3, S4: Connected at time of shipping. * If regeneration option is required for "Model Selection", connect to this terminal.
C		
U	Servo motor power (U)	Connect to motor cable (U, V, W)
V	Servo motor power (V)	
W	Servo motor power (W)	

Control Circuit Power Supply Connector: CNP2 *Accessory

Terminal name	Function	Function details
24V	Control circuit power supply (24V)	24V side of the control circuit power supply (24 VDC) which supplies the controller.
0V	Control circuit power supply (0V)	0V side of the control circuit power supply (24 VDC) which supplies the controller.

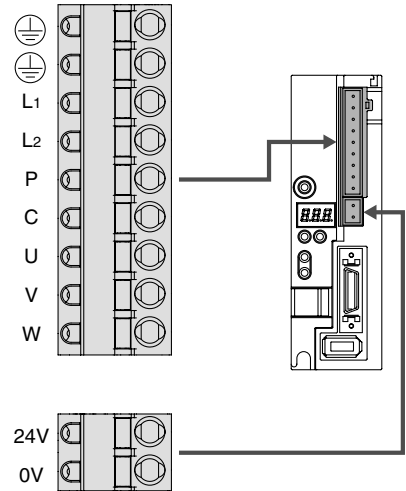

Power Supply Wiring Example: LECSB

LECSB1-□

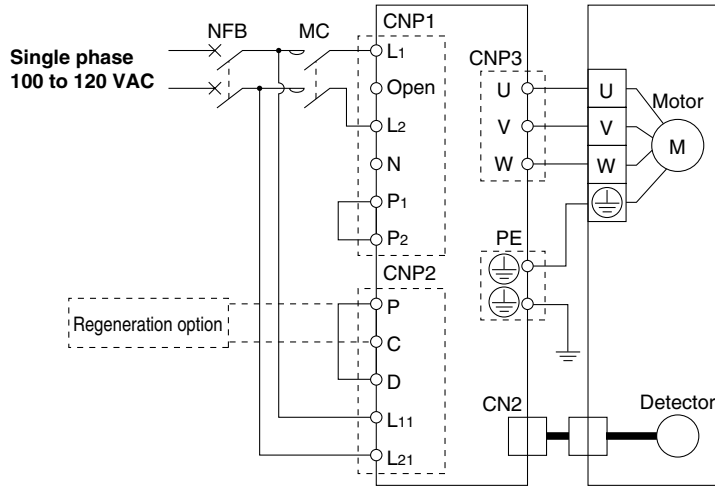

LECSB2-□

For three phase 200 VAC

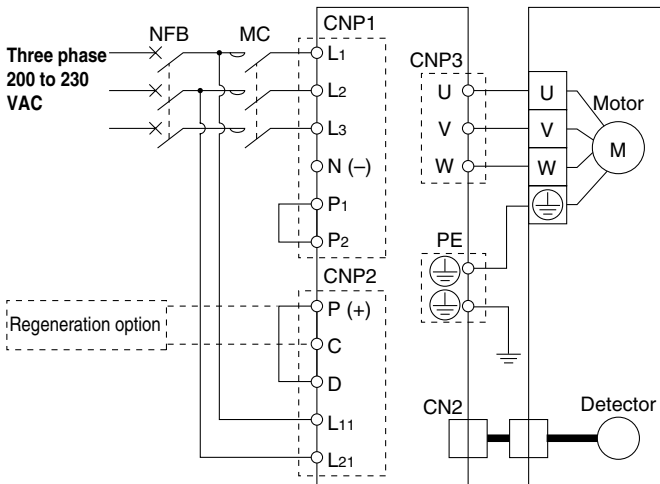

For single phase 200 VAC

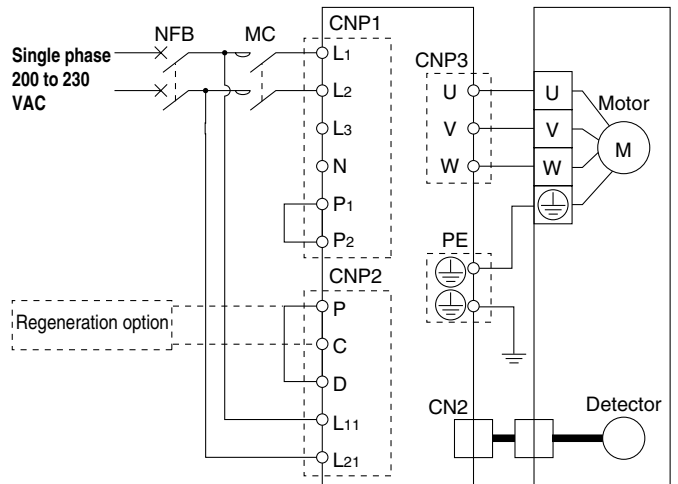

Note) For single phase 200 to 230 VAC, power supply should be connected to L1 and L2 terminals, with nothing connected to L3.

Main Circuit Power Supply Connector: CNP1 *Accessory

Terminal name	Function	Function details
L1	Main circuit power supply	Connect the main circuit power supply. LECSB1: Single phase 100 to 120 VAC, 50/60 Hz Connection terminal: L1,L2 LECSB2: Single phase 200 to 230 VAC, 50/60 Hz Connection terminal: L1,L2 Three phase 200 to 230 VAC, 50/60 Hz Connection terminal: L1,L2,L3
L2		
L3		
N	Regeneration converter	Do not connect.
P1	DC reactor	Connect between P1 and P2. (Connected at time of shipping.)
P2		

Control Circuit Power Supply Connector: CNP2 *Accessory

Terminal name	Function	Function details
P	Regeneration option	Connect between P and D. (Connected at time of shipping.) * If regeneration option is required for "Model Selection", connect to this terminal.
C		
D		
L11	Control circuit power supply (24 V)	24V side of the control circuit power supply (24 VDC) which supplies the controller.
L21	Control circuit power supply (0 V)	0V side of the control circuit power supply (24 VDC) which supplies the controller.

Motor Connector: CNP3 *Accessory

Terminal name	Function	Function details
U	Servo motor power (U)	Connect to motor cable (U, V, W)
V	Servo motor power (V)	
W	Servo motor power (W)	

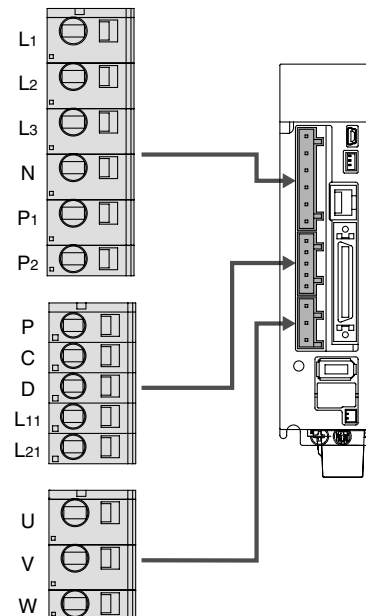

Series LECSA

Series LECSB

Control Signal Wiring Example: LECSA

LECSA□-□

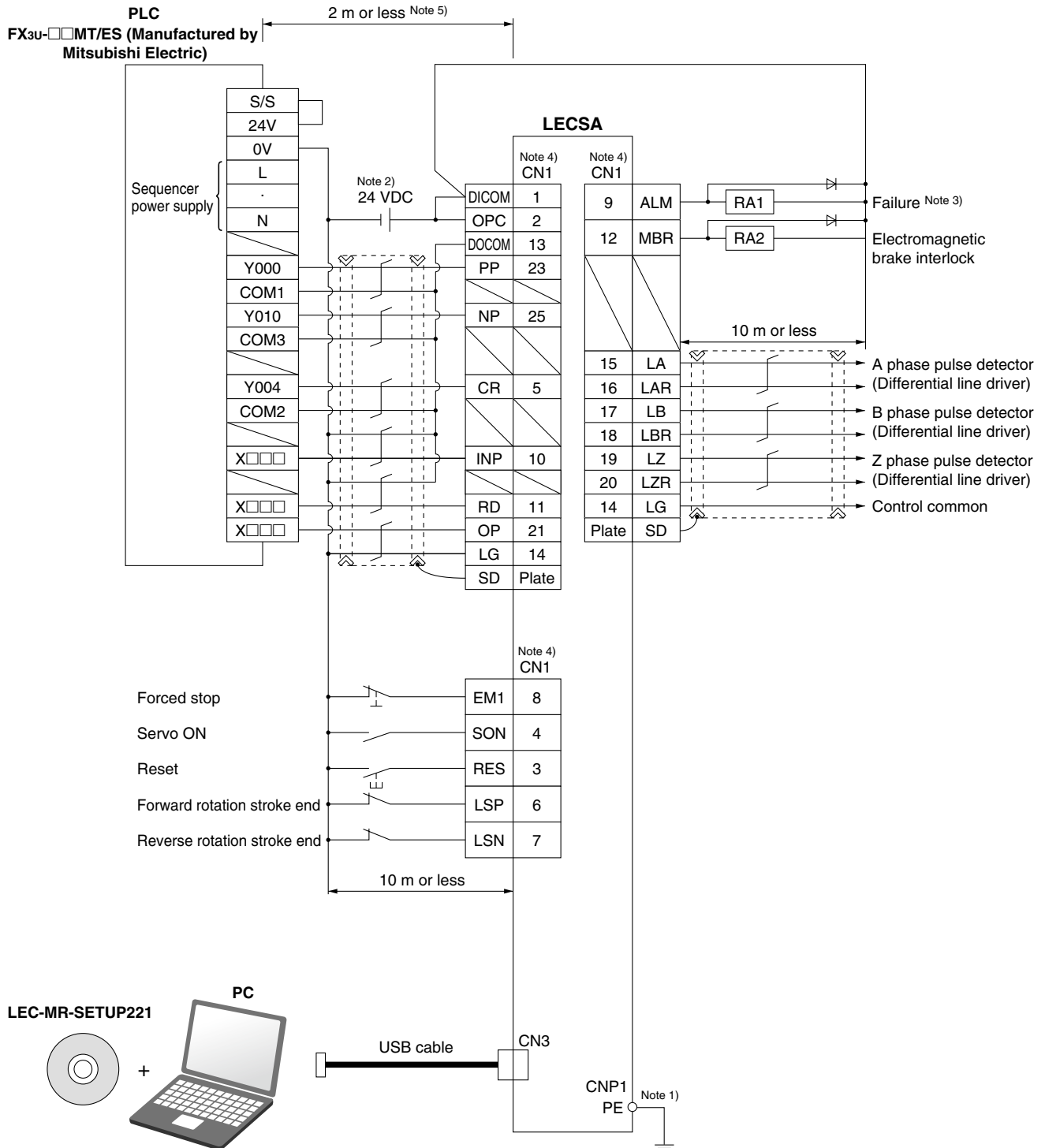

Note 1) For preventing electric shock, be sure to connect the main circuit power supply connector for the servo amplifier (CNP1)'s protective earth (PE) terminal to the control panel's protective earth (PE).

Note 2) For interface use, supply 24 VDC \pm 10% 200 mA using an external source. 200 mA is the value when all I/O command signals are used and reducing the number of inputs/outputs can decrease current capacity. Refer to "Operation Manual" for required current for interface.

Note 3) The failure (ALM) is ON during normal conditions. When it is OFF (alarm occurs), stop the sequencer signal using the sequence program.

Note 4) The same name signals are connected inside the servo amplifier.

Note 5) For command pulse input with an open collector method. When a positioning unit loaded with a differential line driver method is used, it is 10 m or less.

Control Signal Wiring Example: LECSB

LECSB□-□

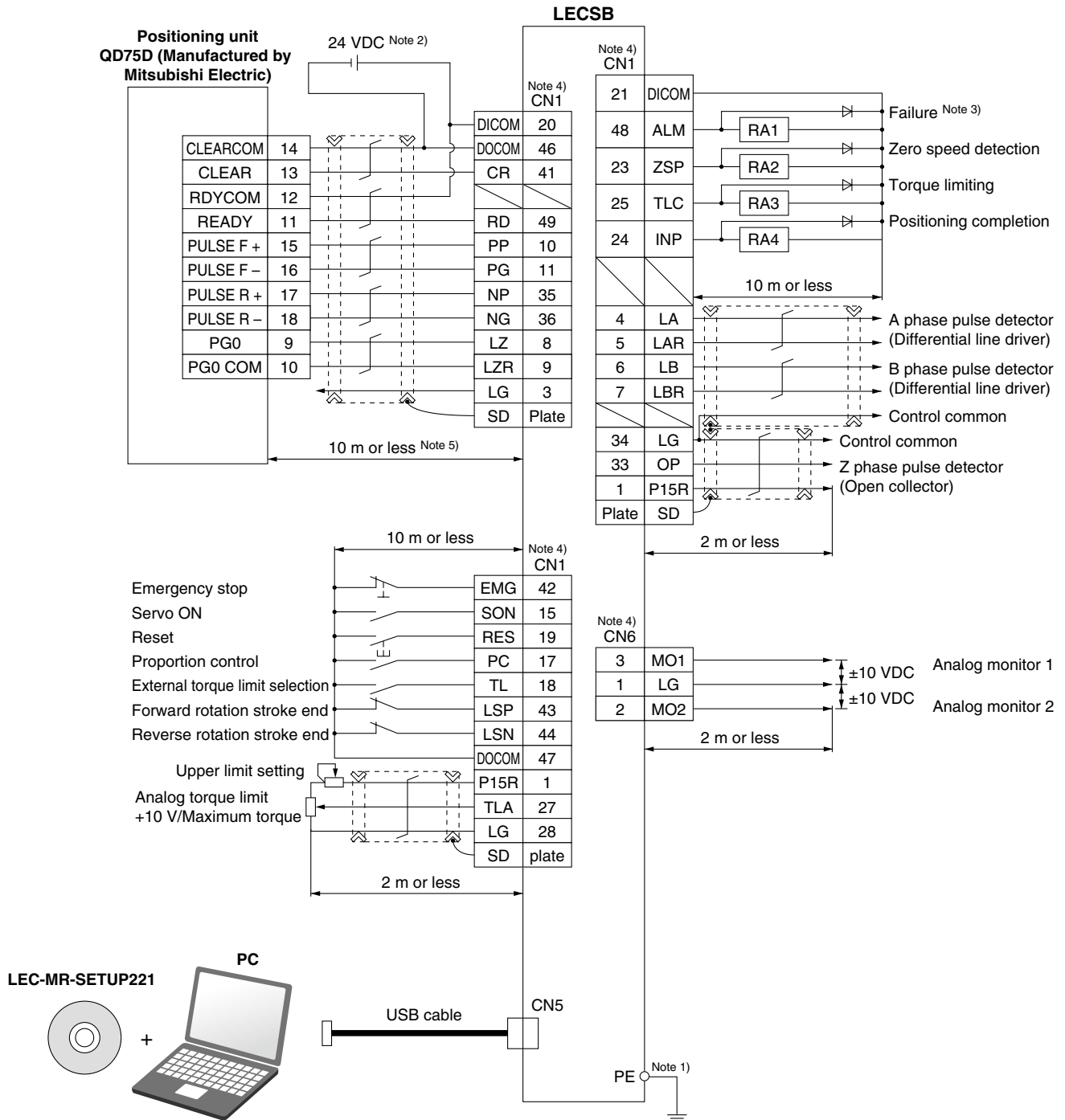

Note 1) For preventing electric shock, be sure to connect the servo amplifier's protective earth (PE) terminal to the control panel's protective earth (PE).
 Note 2) For interface use, supply 24 VDC $\pm 10\%$ 300 mA using an external source.
 Note 3) The failure (ALM) is ON during normal conditions. When it is OFF (alarm occurs), stop the sequencer signal using the sequence program.
 Note 4) The same name signals are connected inside the servo amplifier.
 Note 5) For command pulse input with a differential line driver method. For open collector method, it is 2 m or less.

Series LECSA

Series LECSB

Options

Motor cable, Lock cable, Encoder cable

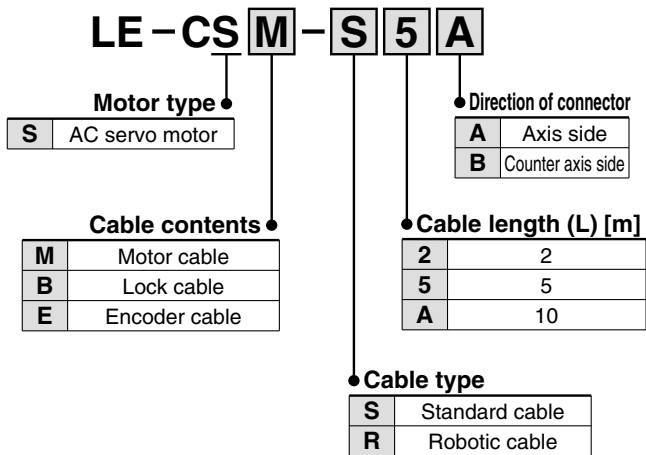

* For cases where the cable is mounted before delivery, the direction of the connector is listed below.
 Motor cable: Counter axis side
 Lock cable: Counter axis side
 Encoder cable: Axis side

LE-CSM-□□: Motor cable

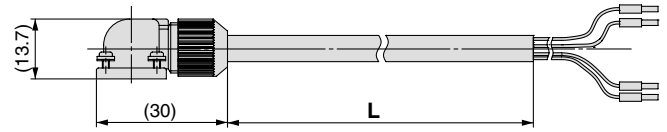

LE-CSB-□□: Lock cable

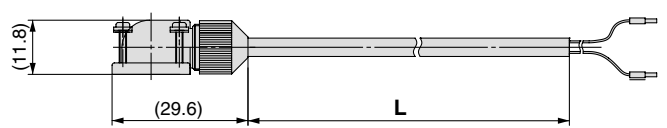

LE-CSE-□□: Encoder cable

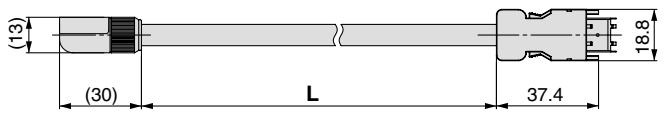

I/O connector

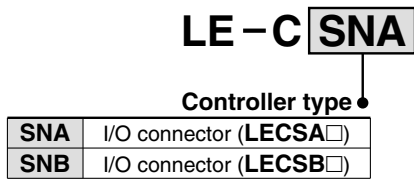

LE-CSNA

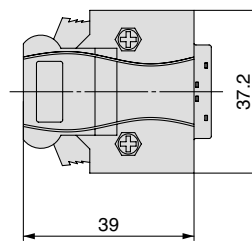

LE-CSNB

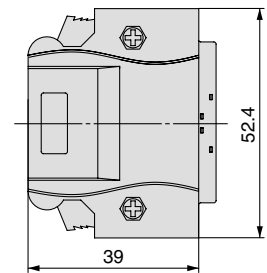

Regeneration option

LEC - MR - RB - □

Regeneration option type	
032	Allowable regeneration power 30 W
12	Allowable regeneration power 100 W

Dimensions [mm]

Model	LA	LB	LC	LD
LEC-MR-RB-032	30	119	99	1.6
LEC-MR-RB-12	40	169	149	2

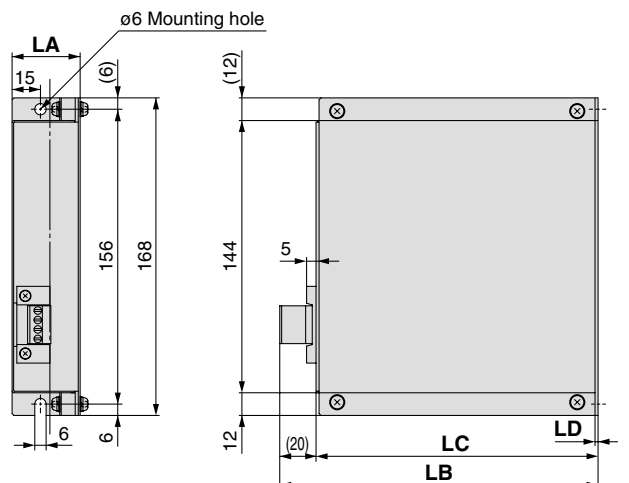

Options

MR Configurator (setup software Japanese version)

LEC – MR – SETUP221

* MRZJW3-SETUP221 manufactured by Mitsubishi Electric.
 Refer to Mitsubishi Electric's website for operating environment and update information.

Compatible PC

When using MR Configurator (setup software), use an IBM PC/AT compatible PC that meets the following operating conditions.

Hardware Requirements

Equipment		MR Configurator (setup software) LEC-MR-SETUP221
Note 1) Note 2) Note 3) PC	OS	Windows®98, Windows®Me, Windows®2000 Professional, Windows®XP Professional/Home Edition, Windows Vista® Home Basic/Home Premium, Business/Ultimate/Enterprise Windows®7 Starter/Home Premium/Professional/ Ultimate/Enterprise IBM PC/AT compatible PC (Japanese version)
	Available HD space	130 MB or more
	Communication interface	Use USB port
Display		Resolution 1024 x 768 or more Must be capable of high color (16 bits) display. The connectable with the above PC
Keyboard		The connectable with the above PC
Mouse		The connectable with the above PC
Printer		The connectable with the above PC
Communication cable		LEC-MR-J3USB

Note 1) Windows, Windows Vista, Windows 7 are registered trademarks of Microsoft Corporation in the United States and/or other countries.

Note 2) This software may not run correctly depending on the PC that you are using.

Note 3) Not compatible with 64-bit Windows® XP and 64-bit Windows Vista®.

USB cable (3 m) for setup software

LEC – MR – J3USB

Battery

LEC – MR – J3BAT



Series **LECSA/LECSB** Specific Product Precautions 1

Be sure to read before handling. Refer to back cover for Safety Instructions and the Operation Manual for Electric Actuator Precautions.
Please download it via our website. <http://www.smcworld.com>

Design/Selection

Warning

- 1. Be sure to apply the specified voltage.**
Otherwise, malfunction and breakage may be caused. If the applied voltage is lower than the specified, it is possible that the load cannot be moved due to an internal voltage drop of the driver. Please check the operating voltage before use.
- 2. Do not operate the product beyond the specifications.**
Otherwise, a fire, malfunction or actuator damage can result. Please check the specifications before use.
- 3. Install an emergency stop circuit outside of the enclosure.**
Please install an emergency stop outside of the enclosure so that it can stop the system operation immediately and intercept the power supply.
- 4. In order to prevent damage due to the breakdown and the malfunction of the driver and its peripheral devices, a backup system should be established previously by giving a multiple-layered structure or a fail-safe design to the equipment, etc.**
- 5. If a danger against the personnel is expected due to an abnormal heat generation, smoking, ignition, etc., of the driver and its peripheral devices, cut off the power supply for the product and the system immediately.**

Handling

Warning

- 1. Do not touch the inside of the driver and its peripheral devices.**
It may cause an electric shock or damage to the driver.
- 2. Do not perform the operation or setting of the product with wet hands.**
It may cause an electric shock.
- 3. Product with damage or the one lacking of any components should not be used.**
It may cause an electric shock, fire, or injury.
- 4. Use only the specified combination between the electric actuator and driver.**
It may cause damage to the actuator or the driver.
- 5. Be careful not to be caught or hit by the workpiece while the actuator is moving.**
It may cause an injury.
- 6. Do not connect the power supply or power on the product before confirming the area to which the workpiece moves is safe.**
The movement of the workpiece may cause an accident.
- 7. Do not touch the product when it is energized and for some time after power has been disconnected, as it is very hot.**
It may lead to a burn due to the high temperature.
- 8. Check the voltage using a tester for more than 5 minutes after power-off in case of installation, wiring and maintenance.**
It may cause an electric shock, fire, or injury.

Handling

Warning

- 9. Static electricity may cause malfunction or break the driver. Do not touch the driver while power is supplied.**
When touching the driver for maintenance, take sufficient measures to eliminate static electricity.
- 10. Do not use the product in an area where dust, powder dust, water, chemicals or oil is in the air.**
It will cause failure or malfunction.
- 11. Do not use the product in an area where a magnetic field is generated.**
It will cause failure or malfunction.
- 12. Do not install the product in the environment of flammable gas, explosive gas and corrosive gas.**
It could lead to fire, explosion and corrosion.
- 13. Radiant heat from strong heat supplies such as a furnace, direct sunlight, etc., should not be applied to the product.**
It will cause failure of the driver or its peripheral devices.
- 14. Do not use the product in an environment subject to a temperature cycle.**
It will cause failure of the driver or its peripheral devices.
- 15. Do not use the product in a place where surges are generated.**
When there are units that generate a large amount of surge around the product (e.g., solenoid type lifters, high frequency induction furnaces, motors, etc.), this may cause deterioration or damage to the product's internal circuit. Avoid supplies of surge generation and crossed lines.
- 16. Do not install the product in an environment under the effect of vibrations and impacts.**
It will cause failure or malfunction.
- 17. When a surge generating load such as a relay or solenoid valve is directly driven, use a product that incorporates a surge absorption element.**

Installation

Warning

- 1. Install the driver and its peripheral devices on a fire-proof material.**
A direct installation on or near a flammable material may cause fire.
- 2. Do not install the product in a place subject to vibrations and impacts.**
It will cause failure or malfunction.
- 3. The driver should be affixed vertically to a vertical wall. Do not cover the driver's exhaust opening.**
- 4. Install the driver and its peripheral devices on a flat surface.**
If the mounting surface is distorted or not flat, an unacceptable force may be added to the housing, etc., to cause troubles.



Series *LECSA/LECSB*

Specific Product Precautions 2

Be sure to read before handling. Refer to back cover for Safety Instructions and the Operation Manual for Electric Actuator Precautions.
Please download it via our website. <http://www.smcworld.com>

Power Supply

⚠ Caution

1. Use a power supply that has low noise between lines and between power and ground.
In cases where noise is high, an isolation transformer should be used.
2. To prevent surges from lightning, an appropriate measure should be taken. Ground the surge absorber for lightning separately from the grounding of the driver and its peripheral devices.

Wiring

⚠ Warning

1. The driver will be damaged if a commercial power supply (100V/200V) is added to the driver's servo motor power (U, V, W). Be sure to check wiring such as wiring mistakes when the power supply is turned on.
2. Connect the ends of the U, V, W wires from the motor cable correctly to the phases (U, V, W) of the servo motor power.
If these wires do not match up, it is unable to control the servo motor.

Grounding

⚠ Warning

1. Be sure to carry out grounding in order to ensure the noise tolerance.
For grounding actuator, connect the copper wire of the actuator to the driver's protective earth (PE) terminal and connect the copper wire of the driver to the earth via the control panel's protective earth (PE) terminal. Do not connect them directly to the control panel's protective earth (PE) terminal.

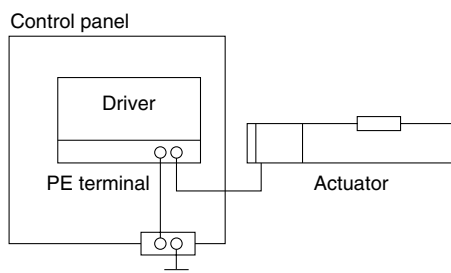

2. In the unlikely event that malfunction is caused by ground, please disconnect the unit from ground.

Maintenance

⚠ Warning

1. Perform a maintenance check periodically.
Confirm wiring and screws are not loose.
Loose screws or wires may cause unintentional malfunction.
2. Conduct an appropriate functional inspection after completing the maintenance.
At times where the equipment or machinery does not operate properly, conduct an emergency stop of the system. Otherwise, an unexpected malfunction may occur and it will become impossible to secure the safety. Conduct a test of the emergency stop in order to confirm the safety of the equipment.
3. Do not disassemble, modify or repair the driver and its peripheral devices.
4. Do not put anything conductive or flammable inside of the driver.
It may cause a fire.
5. Do not conduct an insulation resistance test and withstand voltage test on this product.
6. Ensure sufficient space for maintenance activities.
Design the system that allows required space for maintenance.