

# Single Axis Electric Actuator

## Series **LJ1S**

### Slider Guide

Series	Motor type	Guide type	Mounting orientation	Model	Lead screw lead	Page
					mm	
LJ1S	Standard motor	Slider guide	Horizontal	LJ1S10	20	88
				LJ1S20	20	90
				LJ1S30	20	92
	Standard motor			LJ1S10	20	94
				LJ1S20	20	96
				LJ1S30	20	98

■ Option specifications	Page 100
■ Made to Order	101
• Dust seal specification	116
• TSUBAKI CABLEVEYOR specification	128
■ Construction	137
■ Mounting	140
■ Non-standard Motor Mounting	143
■ Deflection Data	145

## Part Number Designations

**LJ1 S 10 G 1 1 S C - 100 - F W - X10**

**Guide type**

S | Slider guide

**Series**

10 | Series 10  
20 | Series 20  
30 | Series 30

**Motor specification**

Nil	Standard motor
G	Matsushita Electric Industrial Co., Ltd.
R	Mitsubishi Electric Corporation
Y	Yaskawa Electric Corporation

**Motor output**

1	50W
2	100W
3	200W

**Power supply voltage**

1	100/110VAC 50/60Hz 100/115VAC 50/60Hz
2	200/220VAC 50/60Hz 200/230VAC 50/60Hz
0	Without motor

**Stroke**

100 | 20mm

**Lead screw lead**

C | 20mm

**Lead screw type**

S | Slide screw

**Cable entry direction**

F	Axial
R	Right
L	Left
T	Top
B	Bottom

**Limit switch**

Nil	None
W	B contact specification 2 pcs.

**Cable length**

2	2m
3	3m
4	4m
5	5m

**X10** | Non-standard motor

The tables above show the definition for each symbol only and cannot be used for actual model selection.

LJ1  
LG1  
LC1  
LX  
LC6D/LC6C  
Switches

## How to Order

**LJ1S10** **G** **1** **1** **SC** — Stroke — **F** **W** — **X10**

### Motor specification

<b>G</b>	Matsushita Electric Industrial Co., Ltd.
<b>R</b>	Mitsubishi Electric Corporation
<b>Y</b>	Yaskawa Electric Corporation

### Power supply voltage

<b>1</b>	100/115VAC (50/60Hz)
<b>2</b>	200/230VAC (50/60Hz)
<b>0</b>	Without motor

### Cable entry direction

<b>F</b>	Axial
<b>R</b>	Right
<b>L</b>	Left
<b>T</b>	Top
<b>B</b>	Bottom

### Switch

<b>Nil</b>	None
<b>W</b>	N.C. (B contact) 2 pcs.

### Cable entry direction

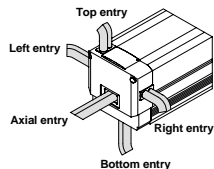

## Specifications

		Standard stroke	mm	100	200	300	400	500	600	700	800	900	1000
<b>Performance</b>	Body weight (without motor)	kg		5.0	5.7	6.5	7.3	8.1	8.9	9.6	10.4	11.2	12.0
	Operating temperature range	°C	5 to 40 (with no condensation)										
	Work load	kg	5										
	Maximum speed	mm/s	300										
<b>Main parts</b>	Positioning repeatability	mm	±0.1										
	Motor	AC servomotor (50W)											
	Encoder	Incremental system											
	Lead screw	Slide screw ø20mm, 20mm lead											
	Guide	Slider guide											
<b>Switch</b>	Motor/Screw connection	With coupling											
	Model	D-Y7GL											
Specifications		Power supply voltage: 4.5 to 28VDC, Current consumption: 10mA or less Control output: Open collector, Load current: 40mA or less, Internal voltage drop: 1.5V or less											

### Intermediate strokes

Strokes other than the standard strokes above are available by special order. Consult SMC.

## Allowable Moment (N·m)

### Allowable static moment

<b>Pitching</b>	1.3
<b>Rolling</b>	1.5
<b>Yawing</b>	0.7

m : Transfer load (kg)  
a : Work piece acceleration (mm/s<sup>2</sup>)  
Me : Dynamic moment  
L : Overhang to work piece center of gravity (mm)

### Allowable dynamic moment

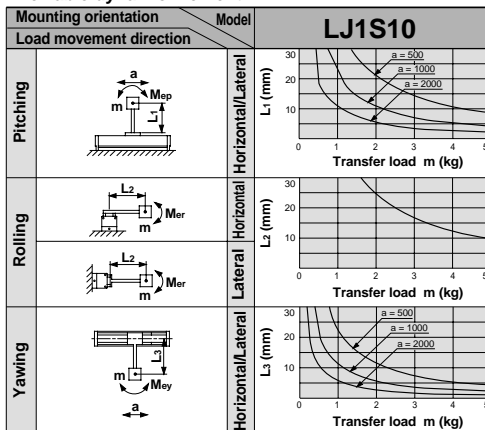

Refer to page 145 for deflection data.

## Dimensions/LJ1S10□1□SC(X10)

**Scale: 15%**

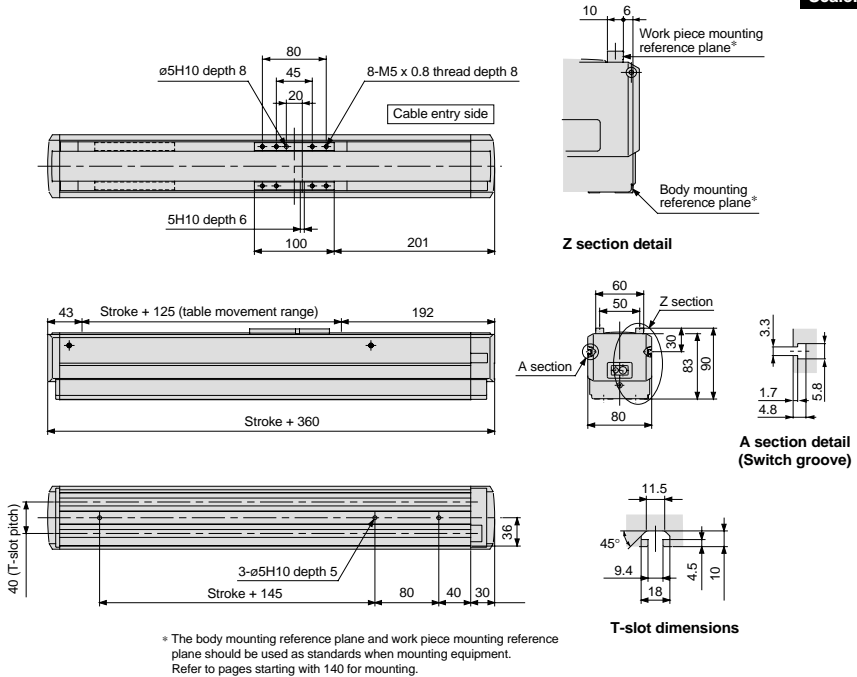

## Positioning Time Guide

		Positioning time (sec.)				
		1	10	100	500	1000
Speed (mm/s)	10	0.5	1.4	10.4	50.4	100.4
	100	0.4	0.5	1.4	5.4	10.4
	150	0.4	0.5	1.1	3.8	7.1
	300	0.4	0.5	0.8	2.2	3.8

\* Values will vary slightly depending on the operating conditions.

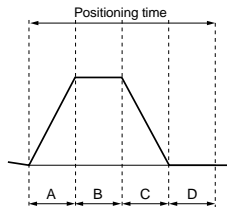

A: Acceleration time  
 B: Constant velocity time  
 C: Deceleration time  
 D: Resting time (0.1sec.)\*  
 Maximum acceleration: 2000mm/s<sup>2</sup>  
 \* The value is a guide when SMC's series LC1 controller is used and may vary depending on the driver capacity.

**Non-standard Motors:** The following motors will be mounted when a motor mounted type is specified.

	Motor output (W)	Power supply voltage (VAC)	Motor model	Compatible driver model
<b>Matsushita Electric Industrial Co., Ltd.</b>	50	100/115	MSM5AZP1A	MSD5A1P1E
		200/230		MSD5A3P1E
<b>Mitsubishi Electric Corporation</b>	50	100/115	HC-PQ053	MR-C10A1
		200/230		MR-C10A
<b>Yaskawa Electric Corporation</b>	50	100/115	SGME-A5BF12	SGDE-A5BP
		200/230	SGME-A5AF12	SGDE-A5AP

\* For motor mounting dimensions, refer to the dimensions for series LJ1S10 on page 143 as a reference for mounting and design.

\* Refer to pages starting with 205 for driver dimensions, etc. Furthermore, for detailed specifications, etc., contact each motor manufacturer.

\* For a non-standard motor specification, when the motor is mounted before shipping, the driver is included but the cable that connects the motor and driver is optional. Refer to page 100 for part numbers.

## Switch Internal Circuit

### D-Y7GL

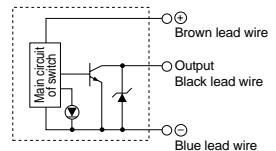

**Non-standard Motor**

**Horizontal Mount**

**Series LJ1S20**

Motor Output

**100W**

Slider Guide

Ground Ball Screw

Ø20mm/20mm lead

**How to Order**

**LJ1S20** **G** 2 **1** **SC** — Stroke — **F** **W** — X10

**Motor specification**

<b>G</b>	Matsushita Electric Industrial Co., Ltd.
<b>R</b>	Mitsubishi Electric Corporation
<b>Y</b>	Yaskawa Electric Corporation

**Power supply voltage**

<b>1</b>	100/115VAC (50/60Hz)
<b>2</b>	200/230VAC (50/60Hz)
<b>0</b>	Without motor

**Cable entry direction**

<b>F</b>	Axial
<b>R</b>	Right
<b>L</b>	Left
<b>T</b>	Top
<b>B</b>	Bottom

**Switch**

<b>Nil</b>	None
<b>W</b>	N.C. (B contact) 2 pcs.

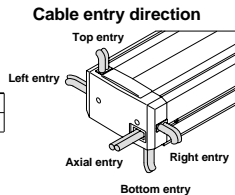

**Specifications**

Standard stroke		mm	100	200	300	400	500	600	700	800	900	1000	1200
<b>Performance</b>	Body weight (without motor)	kg	6.3	7.4	8.5	9.6	10.6	11.7	12.8	13.8	14.9	15.9	18.1
	Operating temperature range	°C	5 to 40 (with no condensation)										
	Work load	kg	10										
	Maximum speed	mm/s	300										
	Positioning repeatability	mm	±0.1										
<b>Main parts</b>	Motor	AC servomotor (100W)											
	Encoder	Incremental system											
	Lead screw	Slide screw ø20mm, 20mm lead											
	Guide	Slider guide											
	Motor/Screw connection	With coupling											
<b>Switch</b>	Model	D-Y7GL											
	Specifications	Power supply voltage: 4.5 to 28VDC, Current consumption: 10mA or less Control output: Open collector, Load current: 40mA or less, Internal voltage drop: 1.5V or less											

**Immediate strokes**

Strokes other than the standard strokes above are available by special order. Consult SMC.

**Allowable Moment (N·m)**

**Allowable static moment**

<b>Pitching</b>	5.5
<b>Rolling</b>	6.0
<b>Yawing</b>	8.5

m : Transfer load (kg)  
a : Work piece acceleration (mm/s<sup>2</sup>)  
Me : Dynamic moment  
L : Overhang to work piece center of gravity (mm)

**Allowable dynamic moment**

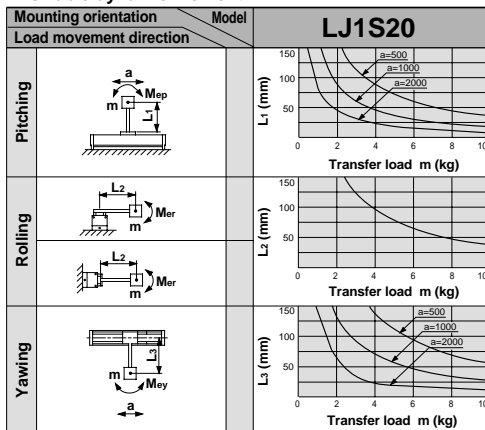

Refer to page 145 for deflection data.

# Non-standard Motor/Horizontal Mount Specification *Series LJ1S20*

## Dimensions/LJ1S20□2□SC(X10)

 When two dimensions are shown, the top dimension is for 100 to 600mm strokes, and the bottom dimension is for 700 to 1200mm strokes.

Scale: 10%

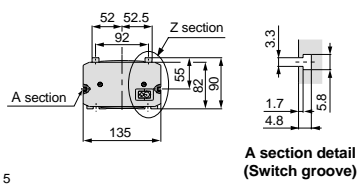
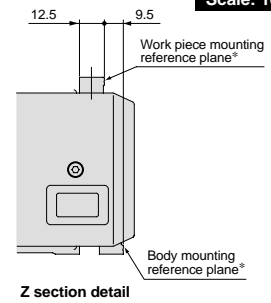
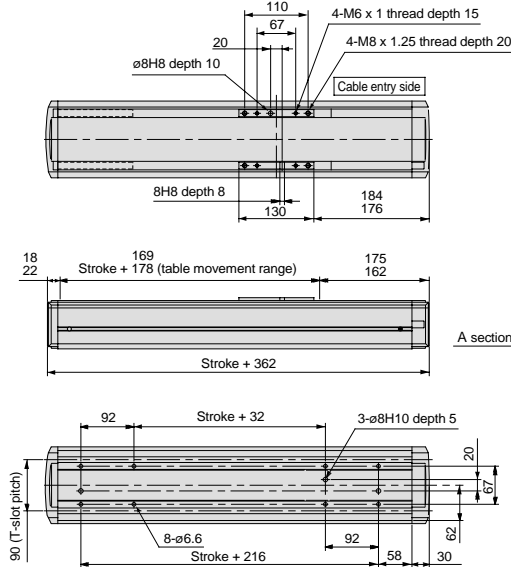

T-slot dimensions

\* The body mounting reference plane and work piece mounting reference plane should be used as standards when mounting onto equipment. Refer to pages starting with 140 for mounting.

## Positioning Time Guide

Positioning distance (mm)	Positioning time (sec.)					
	1	10	100	500	1000	
Speed (mm/s)	10	0.6	1.5	10.5	50.5	120.5
	100	0.5	0.6	1.5	6.5	12.5
	150	0.5	0.6	1.2	4.5	8.5
	300	0.5	0.6	0.9	2.6	4.6

\* Values will vary slightly depending on the operating conditions.

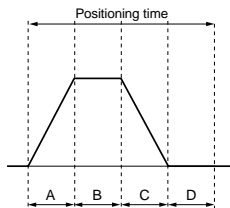

A: Acceleration time  
 B: Constant velocity time  
 C: Deceleration time  
 D: Resting time (0.4sec.)\*  
 \*Maximum acceleration: 2000mm/s<sup>2</sup>  
 \*The value is a guide when SMC's series LC1 controller is used and may vary depending on the driver capacity.

## Non-standard Motors: The following motors will be mounted when a motor mounted type is specified.

	Motor output (W)	Power supply voltage (VAC)	Motor model	Compatible driver model
Matsushita Electric Industrial Co., Ltd.	100	100/115	MSM011P1A	MSD011P1E
		200/230	MSM012P1A	MSD013P1E
Mitsubishi Electric Corporation	100	100/115	HC-PQ13	MR-C10A1
		200/230		MR-C10A
Yaskawa Electric Corporation	100	100/115	SGME-01BF12	SGDE-01BP
		200/230	SGME-01AF12	SGDE-01AP

\* For motor mounting dimensions, refer to the dimensions for series LJ1S20 on page 143 as a reference for mounting and design.  
 \* Refer to pages starting with 205 for driver dimensions, etc. Furthermore, for detailed specifications, etc., contact each motor manufacturer.  
 \* For a non-standard motor specification, when the motor is mounted before shipping, the driver is included but the cable that connects the motor and driver is optional. Refer to page 100 for part numbers.

## Switch Internal Circuit

### D-Y7GL

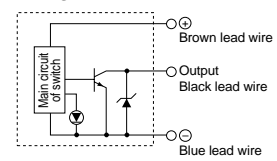

LJ1  
LG1  
LC1  
LX  
LC6D/LC6C  
Switches

## How to Order

**LJ1S30** **G** **3** **1** **SC** — Stroke — **F** **W** — X10

### Motor specification

<b>G</b>	Matsumita Electric Industrial Co., Ltd.
<b>R</b>	Mitsubishi Electric Corporation
<b>Y</b>	Yaskawa Electric Corporation

### Power supply voltage

<b>1</b>	100/115VAC (50/60Hz)
<b>2</b>	200/230VAC (50/60Hz)
<b>0</b>	Without motor

### Cable entry direction

<b>F</b>	Axial
<b>R</b>	Right
<b>L</b>	Left
<b>T</b>	Top
<b>B</b>	Bottom

### Switch

<b>Nil</b>	None
<b>W</b>	N.C. (B contact) 2 pcs.

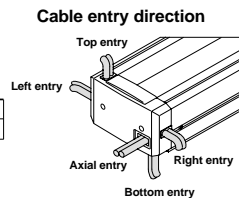

## Specifications

		Standard stroke	mm	200	300	400	500	600	800	1000	1200	1500
<b>Performance</b>	Body weight (without motor)	kg		13.3	15.1	16.9	18.7	20.4	24.6	28.6	32.2	37.6
	Operating temperature range	°C	5 to 40 (with no condensation)									
	Work load	kg	20									
	Maximum speed	mm/s	300									
<b>Main parts</b>	Positioning repeatability	mm	±0.1									
	Motor	AC servomotor (200W)										
	Encoder	Incremental system										
	Lead screw	Slide screw ∅25mm, 20mm lead										
	Guide	Slider guide										
<b>Switch</b>	Motor/Screw connection	With coupling										
	Model	D-Y7GL										
Specifications		Power supply voltage: 4.5 to 28VDC, Current consumption: 10mA or less Control output: Open collector, Load current: 40mA or less, Internal voltage drop: 1.5V or less										

### Immediate strokes

Strokes other than the standard strokes above are available by special order. Consult SMC.

## Allowable Moment (N·m)

### Allowable static moment

<b>Pitching</b>	26.6
<b>Rolling</b>	40.2
<b>Yawing</b>	25.8

m : Transfer load (kg)  
a : Work piece acceleration (mm/s<sup>2</sup>)  
Me: Dynamic moment  
L : Overhang to work piece center of gravity (mm)

### Allowable dynamic moment

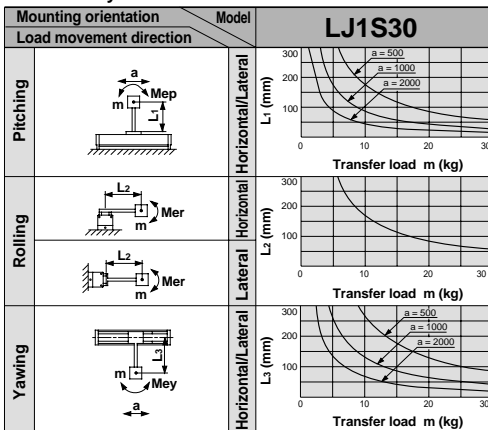

Refer to page 145 for deflection data.

## Dimensions/LJ1S30□3□SC(X10)

Scale: 10%

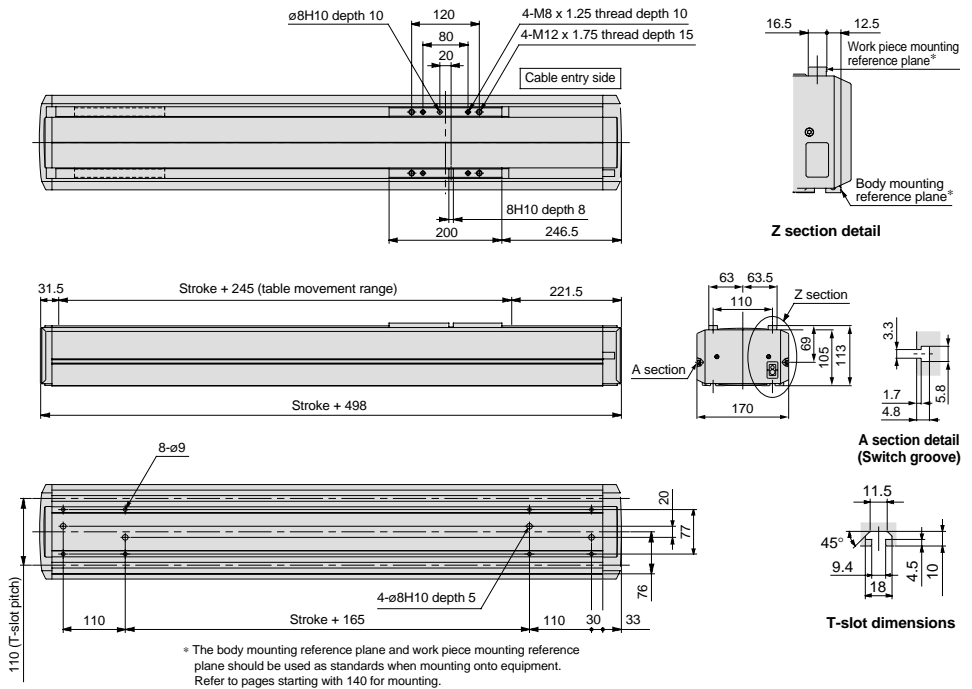

## Positioning Time Guide

Positioning distance (mm)	Positioning time (sec.)					
	1	10	100	750	1500	
Speed (mm/s)	10	0.5	2.1	11.1	76.1	151.1
	100	1.1	1.2	2.1	8.6	16.1
	250	1.1	1.2	1.6	4.2	7.2
	500	1.1	1.2	1.5	2.8	4.3

\* Values will vary slightly depending on the operating conditions.

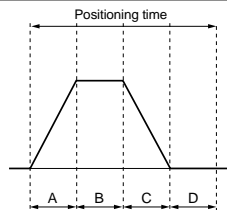

\* The value is a guide when SMC's series LC1 controller is used and may vary depending on the driver capacity.

**Non-standard Motors:** The following motors will be mounted when a motor mounted type is specified.

	Motor output (W)	Power supply voltage (VAC)	Motor model	Compatible driver model
<b>Matsushita Electric Industrial Co., Ltd.</b>	200	100/115	MSM021P1A	MSD021P1E
		200/230	MSM022P1A	MSD023P1E
<b>Mitsubishi Electric Corporation</b>	200	100/115	HC-PQ23	MR-C20A1
		200/230		MR-C20A
<b>Yaskawa Electric Corporation</b>	200	100/115	SGME-02BF12	SGDE-02BP
		200/230	SGME-02AF12	SGDE-02AP

- \* For motor mounting dimensions, refer to the dimensions for series LJ1S30 on page 143 as a reference for mounting and design.
- \* Refer to pages starting with 205 for driver dimensions, etc. Furthermore, for detailed specifications, etc., contact each motor manufacturer.
- \* For a non-standard motor specification, when the motor is mounted before shipping, the driver is included but the cable that connects the motor and driver is optional. Refer to page 100 for part numbers.

## Switch Internal Circuit

### D-Y7GL

