

Integral Fitting Type (Hyper Fittings) Series LVC

How to Order Valves (Single Type)

LVC **2** **0** - S **06** [] [] - [] []

Body class

Symbol	Body class	Orifice dia.
2	2	ø4
3	3	ø8
4	4	ø10
5	5	ø16
6	6	ø22

Valve type

0	N.C.
1	N.O.
2	Double acting

Note) Refer to variations in the table below for valve type combinations.

Option

Nil	None
1	With flow rate adjustment
2	With by-pass
3	With flow rate adjustment & by-pass
4	With indicator

Note) Refer to "Variations" in the table below for option combinations. Options cannot be combined each other.

Applicable tubing size

Symbol	Connecting tubing O.D.	Body class					
		2	3	4	5	6	
Metric sizes							
04	ø4	●					
06	ø6	○	●				
08	ø8		●				
10	ø10		○	●			
12	ø12			○	●		
19	ø19				○	●	
25	ø25					○	
Inch sizes							
03	1/8	●					
05	3/16	●					
07	1/4	○	●				
11	3/8		○	●			
13	1/2			○	●		
19	3/4				○	●	
25	1					○	

○ Basic size ● With reducer

Port B (OUT) different dia. size

Symbol	Application
Nil	Ports A & B same size
Refer to the applicable tubing table to the left.	Different diameter tubings can be selected within the same body class.

Material

Symbol	Body	Actuator section End plate	Dia-phragm	Applicable option				Note
				1	2	3	4	
Nil	PFA	PPS	PTFE	●	●	●	●	—
F	PFA	PVDF	PTFE					Hydrofluoric acid compatible (Only LVC40, 50 type)
N	PFA	PPS	PTFE	●	●	●	●	Ammonium hydroxide compatible

Pilot port thread type

Symbol	Body class	Thread type
Nil	2	M5
	3, 4, 5, 6	Rc 1/8
N	3, 4, 5, 6	NPT 1/8

Variations

Type	Symbol	Model	Orifice diameter					
			Tubing O.D.					
			Model	LVC20	LVC30	LVC40	LVC50	LVC60
			ø4	ø8	ø10	ø16	ø22	
			Metric	4, 6	6, 8, 10	10, 12	12, 19	19, 25
			Inch	1/8, 3/16, 1/4	1/4, 3/8	3/8, 1/2	1/2, 3/4	3/4, 1
			Valve type					
Basic type		N.C.	○	○	○	○	○	
		N.O.	○	○	○	○	○	
		Double acting	○	○	○	○	○	
With flow rate adjustment		N.C.	○	○	○	○	○	
		Double acting	○	○	○	○	○	
With by-pass		N.C.	—	○	○	○	—	
		Double acting	—	○	○	○	—	
With flow rate adjustment & by-pass		N.C.	—	○	○	○	—	
		Double acting	—	○	○	○	—	
With indicator		N.C.	○	○	○	○	○	

VC □

VDW

VQ

VX2

VX □

VX3

VXA

VN □

LVC

LVA

LVH

LVD

LVQ

LQ

LVN

TI/
TIL

PA

PAX

PB

Series LVC

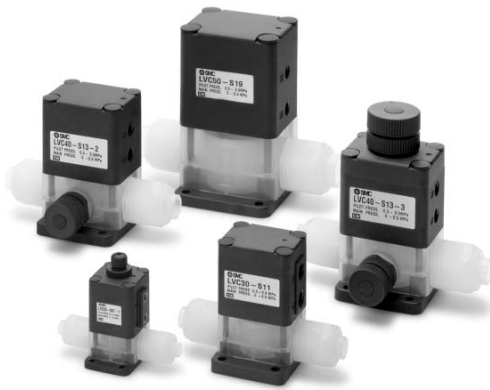

Standard Specifications

Model		LVC20	LVC30	LVC40	LVC50	LVC60
Tubing O.D.	Metric size	6	10	12	19	25
	Inch size	1/4	3/8	1/2	3/4	1
Orifice diameter		ø4	ø8	ø10	ø16	ø22
Flow characteristics	Av x 10 ⁻⁶ m ²	8.4	40.8	60	144	192
	Cv	0.35	1.7	2.5	6	8
Withstand pressure (MPa)		1				
Operating pressure (MPa)		0 to 0.5			0 to 0.4	
Back pressure (MPa)	N.C./N.O.	0.3 or less			0.2 or less	
	Double acting	0.4 or less			0.3 or less	
Valve leakage (cm ³ /min)		0 (with water pressure)				
Pilot air pressure (MPa)		0.3 to 0.5				
Pilot port size		M5	Rc 1/8, NPT 1/8			
Fluid temperature (°C)		0 to 100				
Ambient temperature (°C)		0 to 60				
Weight (kg)		0.09	0.23	0.42	0.86	1.00

 Note 1) Contact SMC if the valve is to be used with vacuum and B → A flow.

Different Diameter Tubing Applicable with Reducer

Different diameter tubing can be selected (within a body class) by using a nut and insert bushing (reducer).

● With reducer

Body class	Tubing O.D.													
	Metric sizes							Inch sizes						
	4	6	8	10	12	19	25	1/8	3/16	1/4	3/8	1/2	3/4	1
2	●	○	—	—	—	—	—	●	●	○	—	—	—	—
3	—	●	●	○	—	—	—	—	—	●	○	—	—	—
4	—	—	—	●	○	—	—	—	—	—	●	○	—	—
5	—	—	—	—	●	○	—	—	—	—	—	●	○	—
6	—	—	—	—	—	●	○	—	—	—	—	—	●	○

 Note) Refer to page 29 for information on changing tubing sizes.

Specific Product Precautions

Be sure to read before handling. Refer to page 17-6-3 for Safety Instructions and 17-5-41 to 17-5-42 for High Purity Chemical Valve Precautions.

Piping

Caution

1. Connect tubing with special tools.

Refer to pages 17-5-35 through 17-5-37 regarding tubing connection and special tools.

2. Tighten the nut to the end surface of the body. As a guide, refer to the proper tightening torques shown below.

Tightening torque for piping

Body class	Torque (Nm)
2	0.3 to 0.4
3	0.8 to 1.0
4	1.0 to 1.2
5	2.5 to 3.0
6	5.5 to 6.0

Suck Back

A change of volume inside the suck back valve pulls in liquid at the end of the nozzle to prevent dripping.

Single type

Symbol

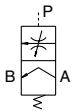

Unit type

Adjustment knob
Adjusts the amount of suck back.

Lock nut
Locks the adjustment knob position.

Adjustment knob
Adjusts the flow rate.

Lock nut
Locks the adjustment knob position.

Symbol

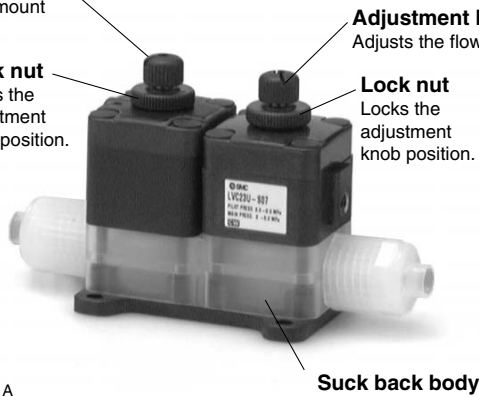
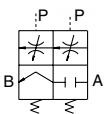

Suck back body

Standard Specifications

Model	LVC23	LVC23U
Tubing O.D.	Metric sizes	(4), 6
	Inch sizes	(1/8), (3/16), 1/4
Orifice diameter	—	ø3
Flow characteristics	$Av \times 10^{-6} m^2$	4.8
	Cv	0.2
Withstand pressure (MPa)	1	
Operating pressure (MPa)	0 to 0.2	
Maximum suck back volume (cm ³)	0.1	
Pilot air pressure (MPa)	0.3 to 0.5	
Pilot port size	M5	
Fluid temperature (°C)	0 to 100	
Ambient temperature (°C)	0 to 60	
Weight (kg)	0.08	0.16

Note 1) Different diameter tubing shown in () can be selected when used with a reducer. Refer to page 17-5-35 for details.

How to Order

LVC 2 3 — S 06

Body class

Symbol	Body class
2	2

Valve type

3	Suck back valve
---	-----------------

Body type

Nil	Single type
U	Unit type with 2 way valve

Port B (OUT) different dia. size

Symbol	Application
Nil	Ports A & B same size
	Different diameter tubing can be selected within the same body class.

Applicable tubing size

Symbol	Connecting tubing O.D.	Body class
Metric sizes		
04	ø4	○
06	ø6	◎
Inch sizes		
03	1/8	○
05	3/16	○
07	1/4	◎

◎ Basic size ○ With reducer

Options

With flow rate adjustment

The flow rate is adjusted by controlling the diaphragm stroke.

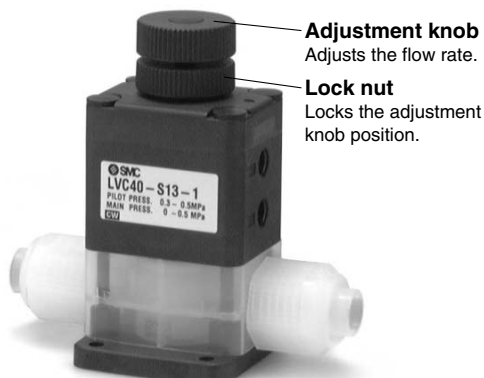

Adjustment knob
Adjusts the flow rate.

Lock nut
Locks the adjustment knob position.

With by-pass

A small amount of fluid from the inlet side is allowed to flow continuously to the outlet side by providing a by-pass inside the body.

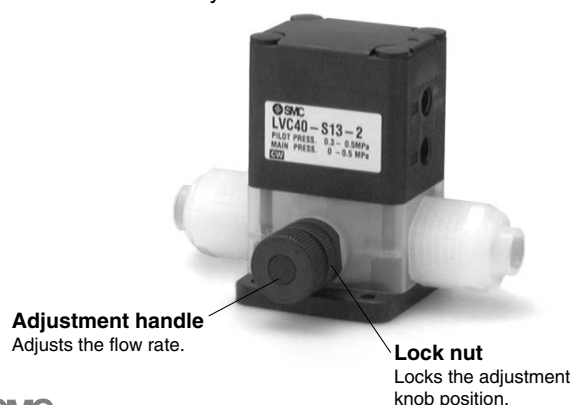

Adjustment handle
Adjusts the flow rate.

Lock nut
Locks the adjustment knob position.

Series LVC

Construction

Standard type
N.C. type

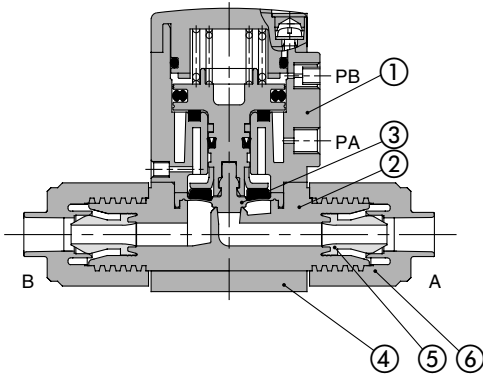

N.O. type

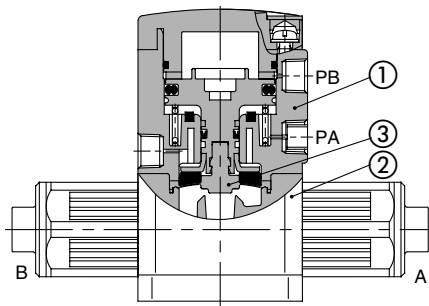

Double acting type

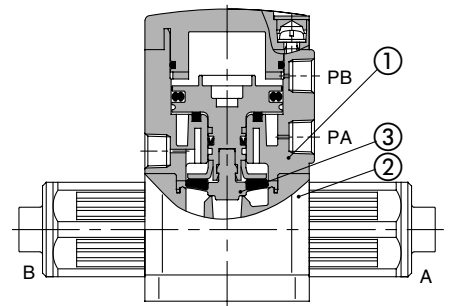

With reducer

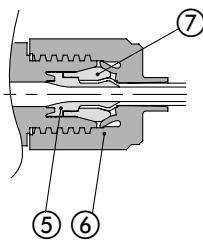

With flow rate adjustment

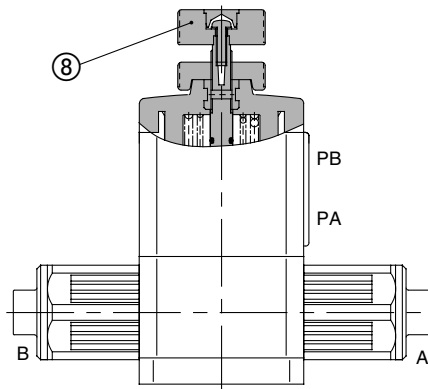

With by-pass

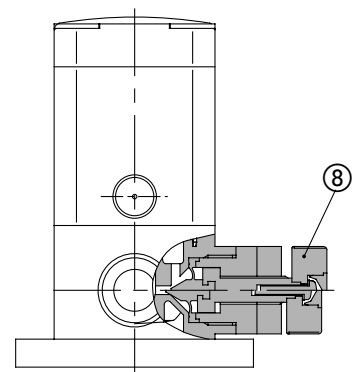

Suck back (single type)

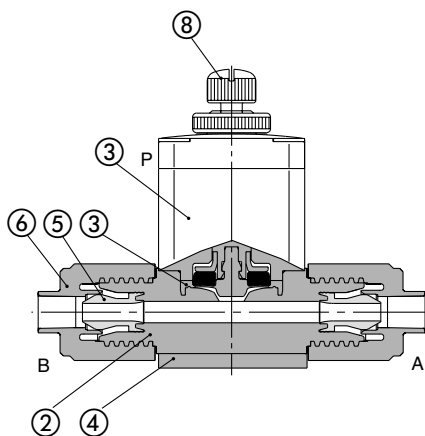

Suck back (unit type)

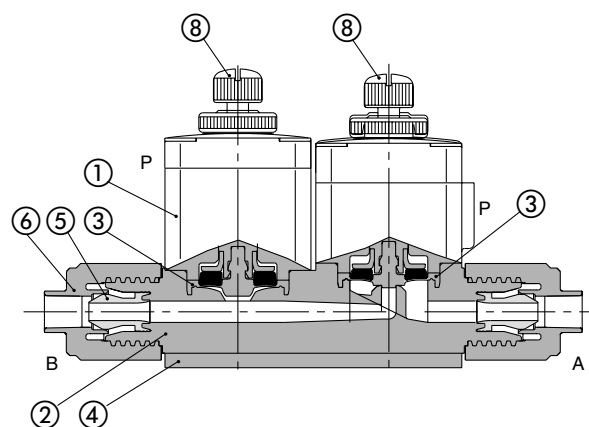

With indicator

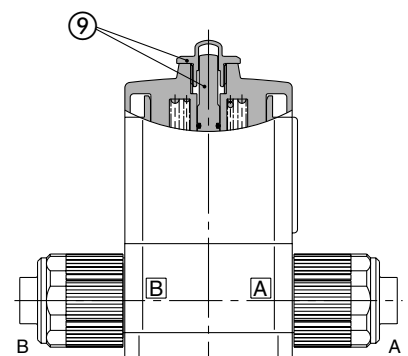

Parts list

No.	Description	Material	Option
1	Actuator section	PPS	PVDF
2	Body	PFA	—
3	Diaphragm	PTFE	—
4	End plate	PPS	PVDF
5	Insert bushing	PFA	—
6	Nut	PFA	—
7	Collar	PFA	—
8	Flow rate adjuster section	PPS	—
9	Indicator	PP	—

Dimensions

Basic type

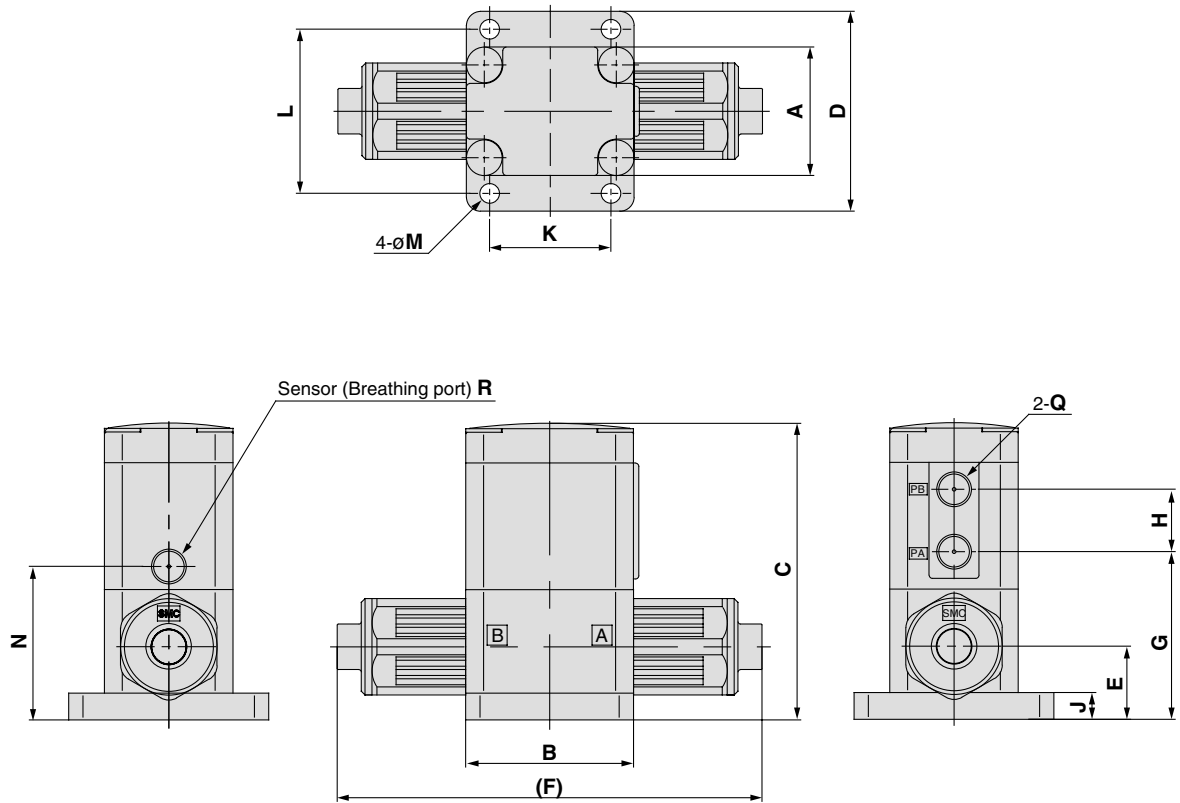

Dimensions

Model	A	B	C	D	E	F	G	H	J	K	L	M	N	Q	R
LVC2□	30	30	54.5	44	11	79	28.5	13	4	20	37	3.5	23.5	M5 x 0.8	M3 x 0.5
LVC3□	36	47	79	56	16.5	106	43	17.5	7.5	34	46	5.5	39		
LVC4□	46	60	96	68	22	131	55	18	8	42	57	5.5	48	Rc 1/8 NPT 1/8	Rc 1/8 NPT 1/8
LVC5□	58	75	129	84	26	154	68	27.5	8	56	71	6.5	62		
LVC6□	58	75	138	84	32	165	77	27.5	8	56	71	6.5	71		

- VC□
- VDW
- VQ
- VX2
- VX□
- VX3
- VXA
- VN□
- LVC**
- LVA
- LVH
- LVD
- LVQ
- LQ
- LVN
- TI/
TIL
- PA
- PAX
- PB

Series LVC

Dimensions

With flow rate adjustment

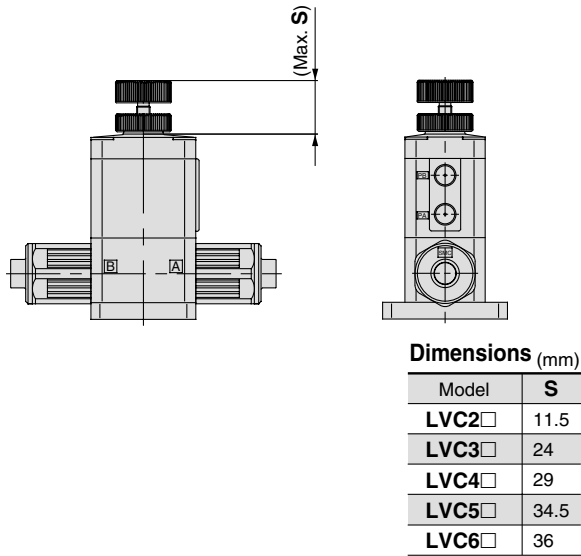

With by-pass

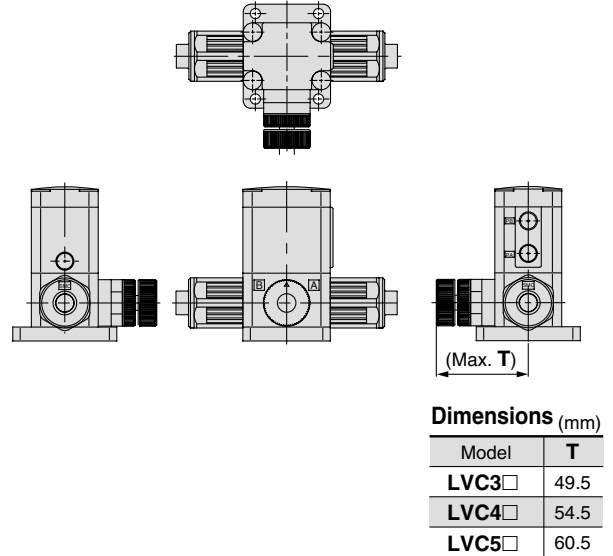

With flow rate adjustment & by-pass

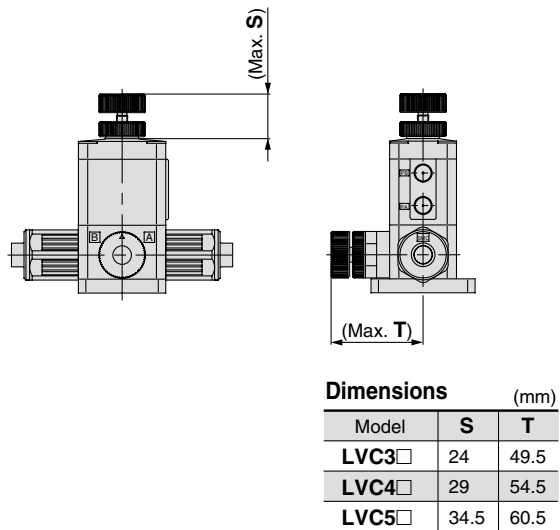

With indicator

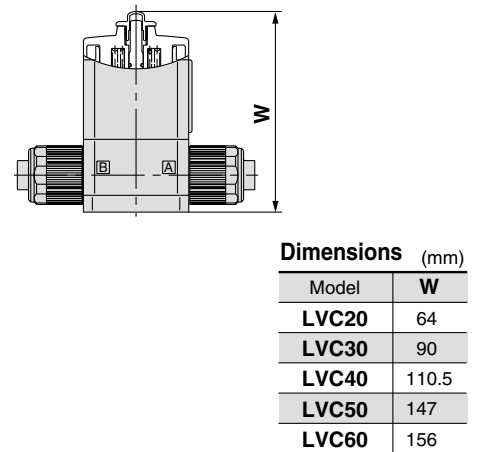

Suck back (Single type)

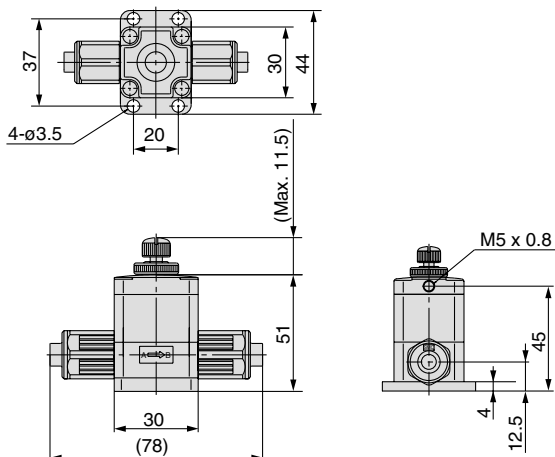

Suck back (Unit type)

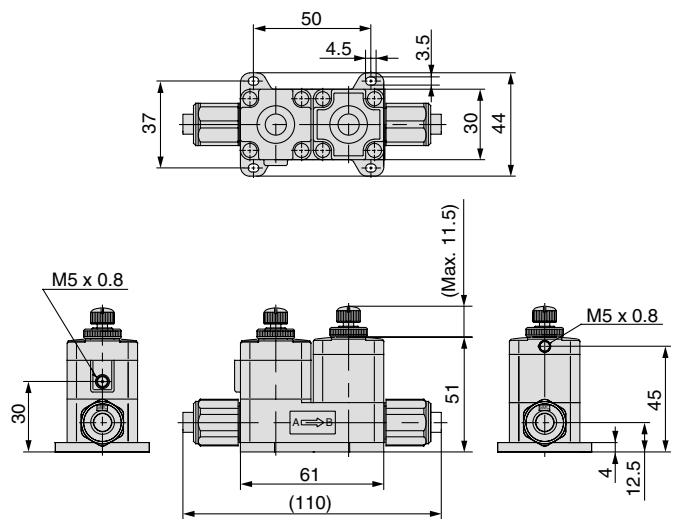

Series LV

Fittings and Special Tools

Fittings

Changing tubing sizes

The tubing size can be changed within the same body class (body size) by replacing the nut and insert bushing.

Body class	Tubing O.D.													
	Metric sizes							Inch sizes						
	4	6	8	10	12	19	25	1/8	3/16	1/4	3/8	1/2	3/4	1
2	●	○	—	—	—	—	—	●	●	○	—	—	—	—
3	—	●	●	○	—	—	—	—	—	●	○	—	—	—
4	—	—	—	●	○	—	—	—	—	—	●	○	—	—
5	—	—	—	—	●	○	—	—	—	—	—	●	○	—
6	—	—	—	—	—	●	○	—	—	—	—	—	●	○

Part composition

	Component parts		
	Nut	Insert	Collar (insert assembly)
○ Basic size	Yes	Yes	No
● Reducer type	Yes	Yes	Yes

Changing the tubing size

Example) Changing the tubing from an O.D. 1/4" to O.D. 1/8" in body class 2.

Prepare an insert bushing and nut for 1/8" O.D. tubing (LQ-2U03) and change the tubing size.
(Refer to the section on how to order fitting parts.)

Note) Tubing is sold separately.

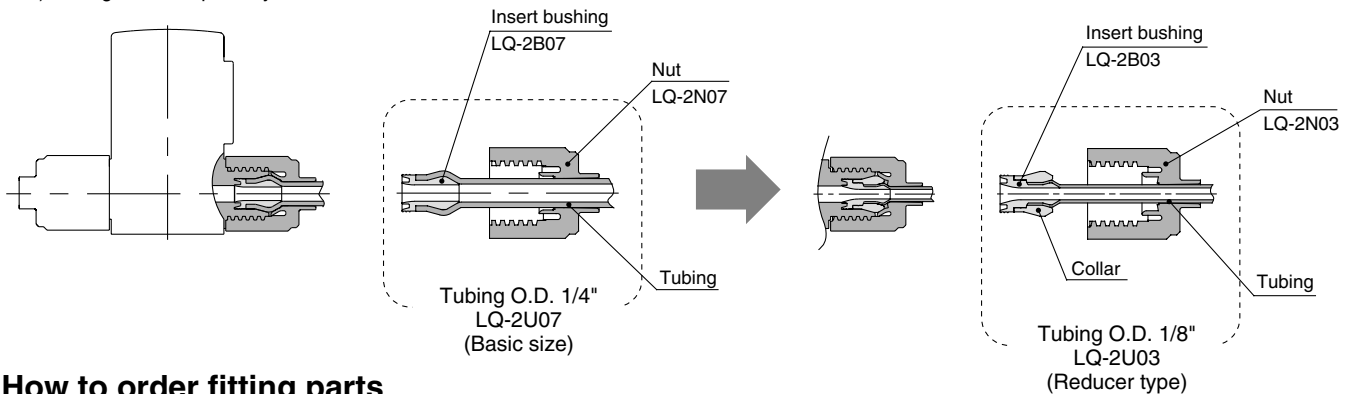

How to order fitting parts

LQ - **2** **U** **03**

* Type U is recommended when changing tubing sizes.

Type of fitting

Symbol	Applicable fitting
Nil	LQ2
1	LQ1

Body class

Symbol	Body class	Applicable fitting
2	2	LQ2
3	3	
4	4	
5	5	
6	6	LQ1

Type of part

Symbol	Type of part
U	Insert bushing & nut
B	Insert bushing
N	Nut

Tubing size

Symbol	Tubing O.D.	Body class	Applicable fitting
03	1/8"	2	LQ2
04	ø4		
05	3/16"		
06	ø6		
07	1/4"		
08	ø8		
10	ø10	3	LQ2
07	1/4"		
11	3/8"		
10	ø10	4	LQ2
12	ø12		
11	3/8"		
13	1/2"	5	LQ2
12	ø12		
13	1/2"		
19	3/4", ø19	6	LQ1
19	3/4", ø19		
25	1", ø25		

VC□

VDW

VQ

VX2

VX□

VX3

VXA

VN□

LVC

LVA

LVH

LVD

LVQ

LQ

LVN

TI/
TIL

PA

PAX

PB

Special Tools

How to order fitting jigs

LQ-G J [] - [] - []

Insert pin material

Nil	Resin
S	Stainless steel (J/K type only)

Insert pin/Holder type

Nil	Metric size
N	Inch size

Note 1) Compatible pins and holders are included with all sizes. (with the parts case)

Type

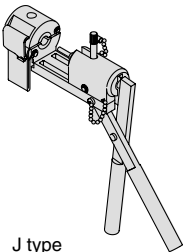
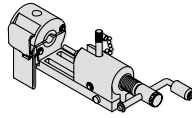
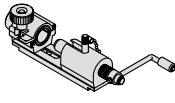
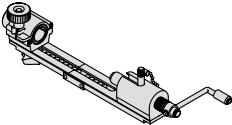
Symbol	Body class	Image	
J / K	1, 2		
		J type	K type
L / M	1, 2, 3, 4, 5, 6		
		L type	M type (for short piping)

Option (L/M type only)

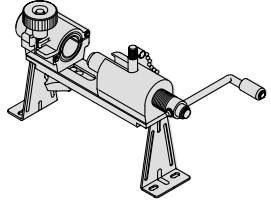
Symbol	Option	Image
Nil	None	
B	With bracket	

Option



	Description	Part No.
Bracket assembly		LQ-GBL

Table 1 Tubing size symbols

Type	Body Class	Tubing O.D.															
		Metric sizes								Inch sizes							
		ø3	ø4	ø6	ø8	ø10	ø12	ø19	ø25	1/8"	3/16"	1/4"	3/8"	1/2"	3/4"	1"	
J	1	03	04	—	—	—	—	—	—	03	—	—	—	—	—	—	
	2	—	04	06	—	—	—	—	—	03	05	07	—	—	—	—	
L	1	03	04	—	—	—	—	—	—	03	—	—	—	—	—	—	
	2	—	04	06	—	—	—	—	—	03	05	07	—	—	—	—	
	3	—	—	06	08	10	—	—	—	—	—	07	11	—	—	—	
	4	—	—	—	—	10	12	—	—	—	—	—	11	13	—	—	
	5	—	—	—	—	—	12	19	—	—	—	—	—	13	19	—	
	6	—	—	—	—	—	—	19	25	—	—	—	—	—	19	25	

Replacement parts

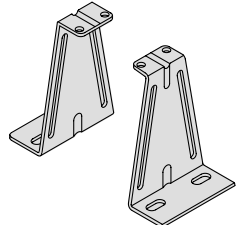
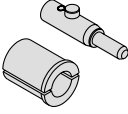
Description	Part No.								
 Insert pin holder assembly (with the parts case)	LQ-GP J [] - [] Type Insert pin material (J/K type only) <table border="1"> <tr><td>Nil</td><td>Resin</td></tr> <tr><td>S</td><td>Stainless steel</td></tr> </table> <table border="1"> <tr><td>Nil</td><td>Metric sizes</td></tr> <tr><td>N</td><td>Inch sizes</td></tr> </table>	Nil	Resin	S	Stainless steel	Nil	Metric sizes	N	Inch sizes
Nil	Resin								
S	Stainless steel								
Nil	Metric sizes								
N	Inch sizes								
 Insert pin (single)	LQ-GP 2 J [] - 07 Body class (Refer to Table 1) Type Insert pin material (J/K type only) <table border="1"> <tr><td>Nil</td><td>Resin</td></tr> <tr><td>S</td><td>Stainless steel</td></tr> </table> Tubing size symbol (Refer to Table 1)	Nil	Resin	S	Stainless steel				
Nil	Resin								
S	Stainless steel								
 Holder (single)	LQ-GH J [] - 07 Tubing size symbol (Refer to Table 1) Type								

Note 1) Replacement part type J shows the parts for LQ-GJ and LQ-GK. Replacement part type L shows the parts for LQ-GL and LQ-GM.

Special Tools

Dimensions

LQ-GJ

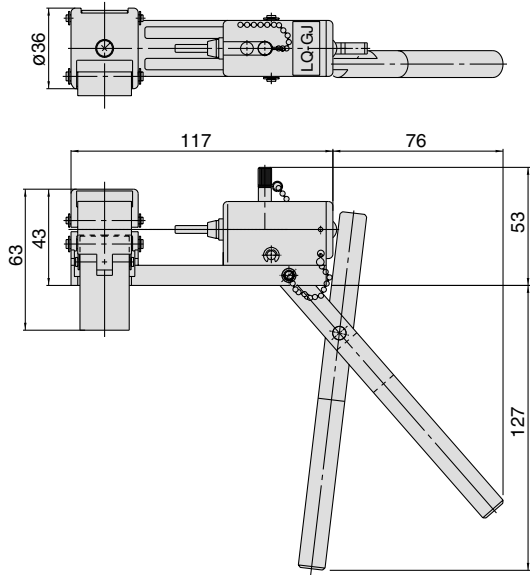

LQ-GK

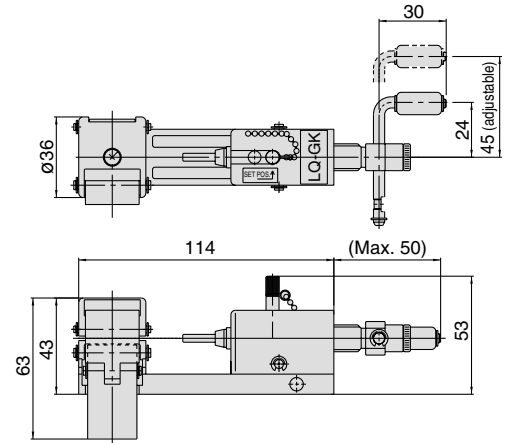

LQ-GM

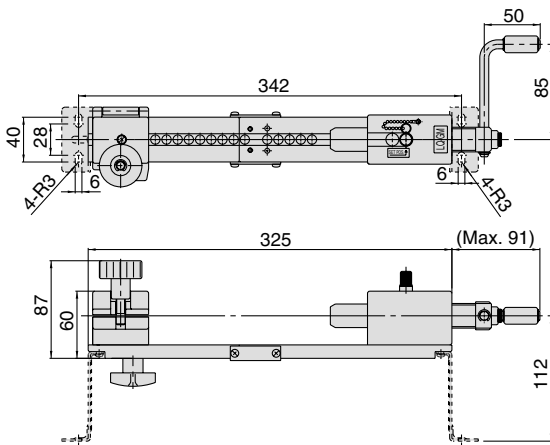

LQ-GL

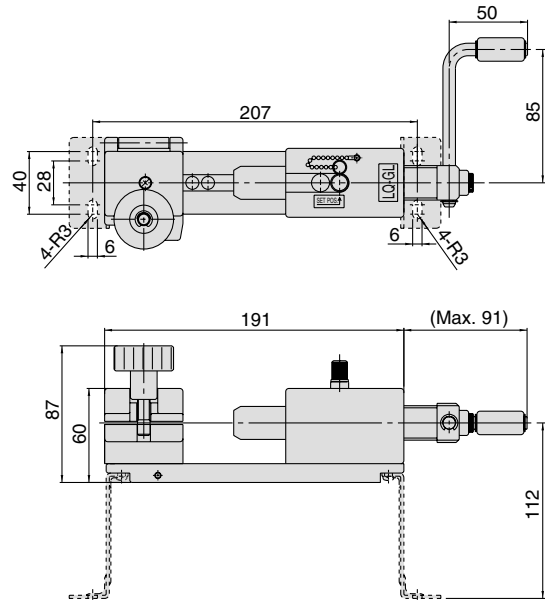

VC

VDW

VQ

VX2

VX

VX3

VXA

VN

LVC

LVA

L VH

LVD

LQV

LQ

LVN

TI/
TIL

PA

PAX

PB

Fitting Assembly Procedure

Assemble fittings following the procedure shown below.

J type

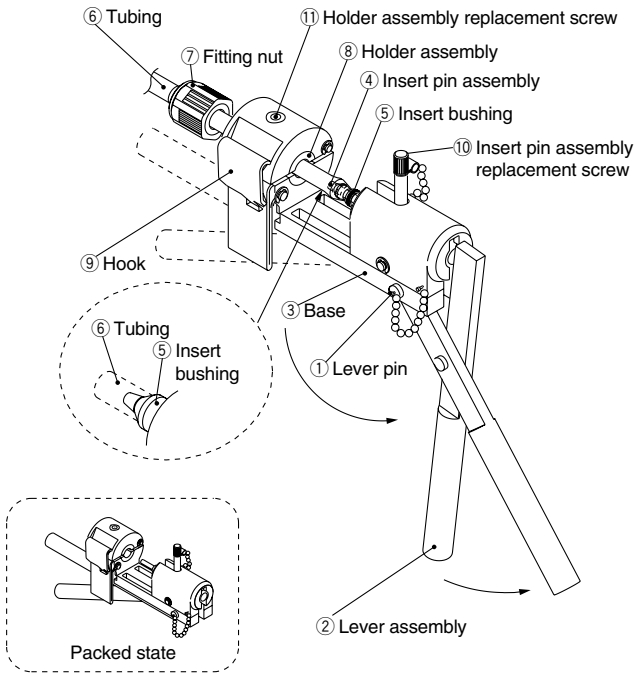

K type

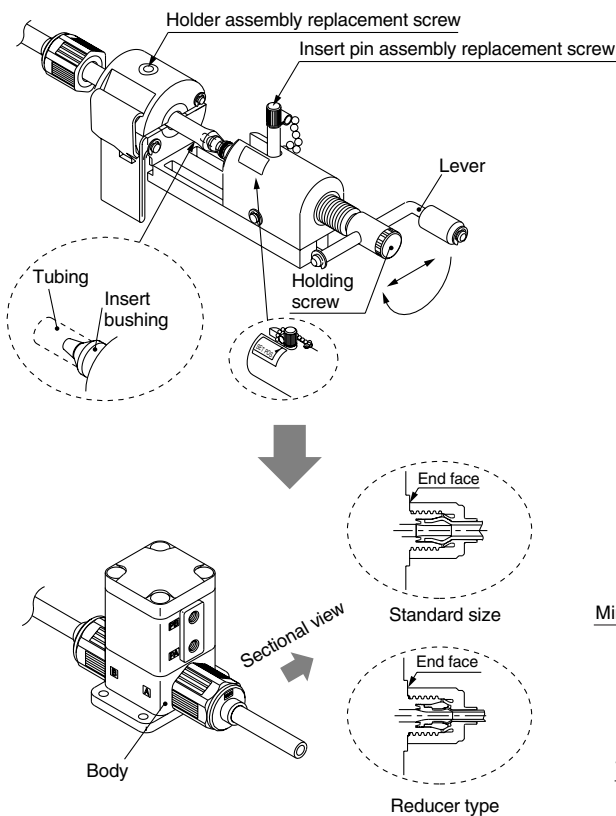

J type fitting assembly procedure

- 1 Pull out the lever pin ①. Rotate the lever assembly ② to align the holes on the lever assembly ② and the base ③. Insert the lever pin ① into the holes to fix the lever assembly ②.
 - 2 Place the insert bushing ⑤ on the insert pin assembly ④.
 - 3 Cut the end of the tubing ⑥ at a right angle and pass it through the fitting nut ⑦. After placing the tubing ⑥ in the holder assembly ⑧, push it onto the insert bushing ⑤ until it stops and clamp it with the hook ⑨.
- ⚠ Caution**
- When the tubing ⑥ is curved, straighten it out before using it.
 - The tubing ⑥ may slip if there is oil or dust, etc., on the holder assembly ⑧. Remove the contamination using alcohol or another suitable cleaner.
- 4 Press the insert bushing ⑤ into the tubing ⑥ by turning the lever assembly ②.
 - 5 To replace the insert pin assembly ④ and holder assembly ⑧, use the insert pin assembly replacement screw ⑩ and the holder assembly replacement screws ⑪, respectively.

K type fitting assembly procedure

- For procedure to set and press fit the insert pin assembly, refer to L, M type fitting assembly procedures.
- For procedure to set the tubing, refer to J type procedure.

- 1 } Refer to J type assembly procedure.
- 5 }
- 6 Tighten the fitting nut ⑦ until it reaches the prescribed position on the body (end face). As a guide, refer to the proper tightening torques shown below.

Nut tightening torque for piping

Body class	Torque (Nm)	
	LQ1	LQ2
2	0.3 to 0.4	1.5 to 2.0

Note 1) In case of body class 1, the nut should be tightened manually.

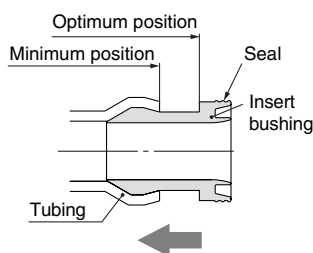

⚠ Precautions on installation

- Be careful not to scratch or dent the seal of the insert bushing. (Refer to the illustration on the left.)
- When the insert bushing inserted, its tubing end should be closer to seal side than the minimum position. (Refer to the illustration on the left.)

Fitting Assembly Procedure

Assemble fittings following the procedure shown below.

L type

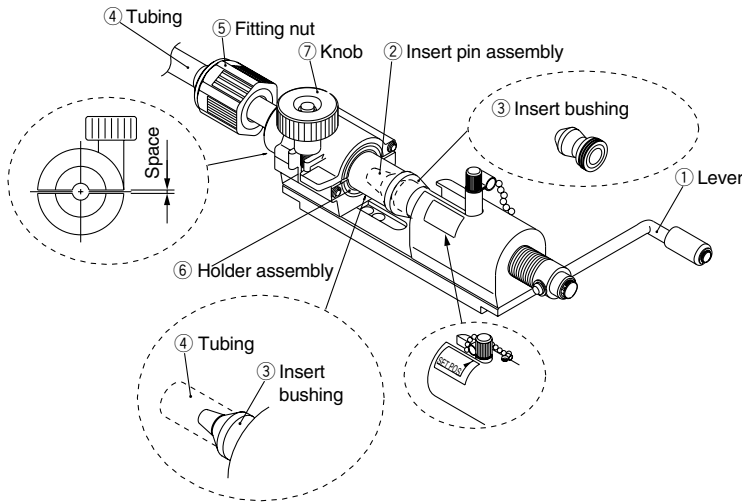

M type

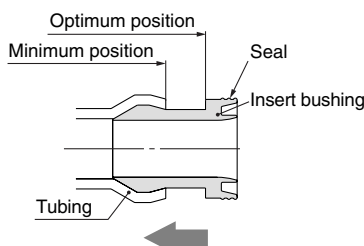
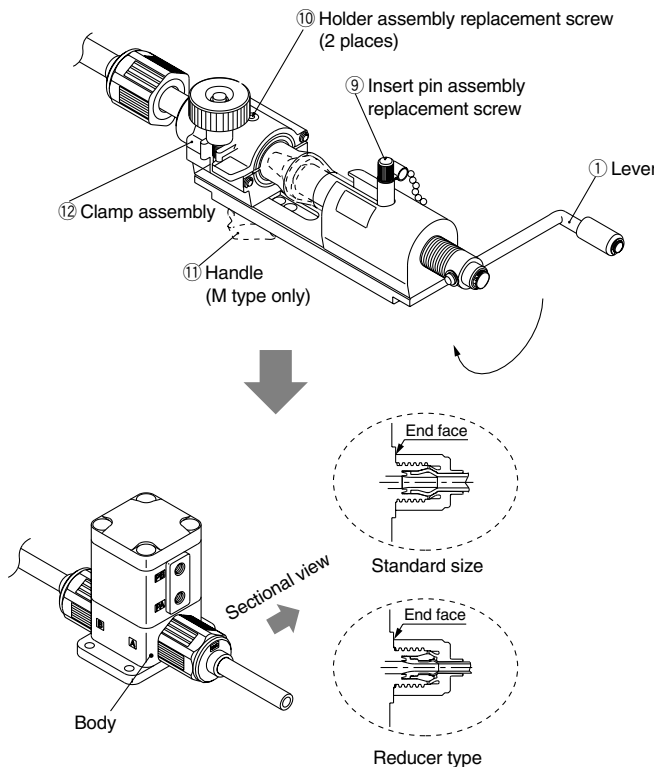

L and M type fitting assembly procedure

- 1 Turn the lever ① and move to SET POS.
- 2 Place the insert bushing ③ on the insert pin assembly ②.
- 3 Cut the end of the tubing ④ at a right angle and pass it through the fitting nut ⑤. After placing the tubing ④ in the holder assembly ⑥, push it onto the insert bushing ③ until it stops and clamp it with the knob ⑦. When tightening the tubing ④ with the knob ⑦, maintain a uniform gap on both sides of the holder.
- ⚠ Caution**
 - When the tubing ④ is curved, straighten it out before using it.
 - The tubing ④ may slip if there is oil or dust, etc. on the holder assembly ⑥. Remove the contamination using alcohol or another suitable cleaner.
- 4 Press the insert bushing ③ into the tubing ④ by turning the lever ①. (Pressing in can be accomplished with 2 or 3 turns of the lever ①.)
- 5 To replace the insert pin assembly ② and holder assembly ⑥, use the insert pin assembly replacement screw ⑨ and the holder assembly replacement screws ⑩, respectively.
- 6 In case of M type for short piping, remove the handle ⑪, slide the clamp assembly ⑫ to attain the specified length, then secure it again with the handle ⑪.
- 7 Tighten the fitting nut ⑤ to the prescribed position on the body (end face). As a guide, refer to the proper tightening torques shown below.

Nut tightening torque for piping

Body class	Torque (Nm)	
	LQ1	LQ2
2	0.3 to 0.4	1.5 to 2.0
3	0.8 to 1.0	3.0 to 3.5
4	1.0 to 1.2	7.5 to 9
5	2.5 to 3.0	11 to 13
6	5.5 to 6.0	—

 Note 1) In case of body class 1, the nut should be tightened manually.

⚠ Precautions on installation

- Be careful not to scratch or dent the seal of the insert bushing. (Refer to the illustration on the left.)
- When the insert bushing inserted, its tubing end should be closer to seal side than the minimum position. (Refer to the illustration on the left.)

VC□

VDW

VQ

VX2

VX□

VX3

VXA

VN□

LVC

LVA

LVH

LVD

LVQ

LQ

LVN

TI/
TIL

PA

PAX

PB



Applicable Fluids

Material and fluid compatibility check list for air and manually operated high purity valves

Chemical	Body material			Diaphragm material		
	Stainless steel SUS316	Fluoro resin PFA	Polyphenylene sulfide resin PPS	Fluoro resin PTFE	Nitrile rubber NBR	Ethylene propylene rubber EPR
Acetone	○	○ Note 1)	○ Note 1)	○ Note 2)	×	×
Ammonium hydroxide	○	○	○	○ Note 2)	×	×
Isobutyl alcohol	○	○ Note 1)	○ Note 1)	○ Note 2)	○	○
Isopropyl alcohol	○	○ Note 1)	○ Note 1)	○ Note 2)	○	○
Hydrochloric acid	×	○	○	○	×	×
Ozone (dry)	○	○	○	○	×	○
Hydrogen peroxide Concentration 5% or less, 50°C or less	×	○	○	○	×	×
Ethyl acetate	○	○ Note 1)	○ Note 1)	○ Note 2)	×	×
Butyl acetate	○	○ Note 1)	○ Note 1)	○ Note 2)	×	×
Nitric acid (except fuming nitric acid) Concentration 10% or less	×	○	○	○ Note 2)	×	×
DI water	○	○	○	○	×	○
Sodium hydroxide Concentration 50% or less	○	○	○	○	×	×
Nitrogen gas	○	○	○	○	○	○
Super pure water	×	○	○	○	×	×
Toluene	○	○ Note 1)	○ Note 1)	○ Note 2)	×	×
Hydrofluoric acid	×	○	×	○ Note 2)	×	×
Sulfuric acid (except fuming sulfuric acid)	×	○	×	○ Note 2)	×	×
Phosphoric acid Concentration 80% or less	×	○	×	○	×	×



The material and fluid compatibility check list provides reference values as a guide only.

Note 1) Use a stainless steel body, as static electricity may be generated.

Note 2) Use caution as permeation may occur and any permeated fluid could effect other material parts.

Table symbols

○ : Can be used

○ : Can be used in certain conditions

× : Cannot be used

- Compatibility is indicated for fluid temperatures of 100°C or less.
- The material and fluid compatibility check list provides reference values as a guide only, therefore we do not guarantee the application to our product.
- The data above is based on the information presented by the material manufacturers.
- SMC is not responsible for its accuracy and any damage happened because of this data.



Series LV

High Purity Chemical Valve Precautions 1

Be sure to read before handling.

Design & Selection

Warning

1. Confirm the specifications.

Give careful consideration to operating conditions such as the application, fluid and environment, and use within the operating ranges specified in this catalog.

2. Fluids

Operate after confirming the compatibility of the product's component materials with fluids, using the check list on features page 17-5-40. Contact SMC regarding fluids other than those in the check list.

Operate within the indicated fluid temperature range.

3. Maintenance space

Ensure the necessary space for maintenance and inspections.

4. Fluid pressure range

Keep the supplied fluid pressure within the operating pressure range shown in the catalog.

5. Ambient environment

Operate within the ambient operating temperature range. After confirming the compatibility of the product's component materials with the ambient environment, operate so that fluid does not adhere to the product's exterior surfaces.

6. Liquid seals

When circulating fluid

Provide a relief valve in the system so that fluid does not get into the liquid seal circuit.

7. Countermeasures for static electricity

Since static electricity may be generated depending on the fluid being used, implement suitable countermeasures.

Mounting

Warning

1. If air leakage increases or equipment does not operate properly, stop operation.

After mounting, perform suitable function and leak tests to confirm that the mounting is correct.

2. Instruction manual

Mount and operate the product after reading the manual carefully and understanding its contents. Also keep the manual where it can be referred to as necessary.

Piping

Caution

1. Preparation before piping

Before piping is connected, it should be thoroughly blown out with air (flushing) or washed to remove chips, cutting oil and other debris from inside the pipe.

Install piping so that it does not apply pulling, pressing, bending or other forces on the valve body.

2. Use the tightening torques shown below when making connections to the pilot port.

Operating port tightening torque

Operating port	Torque (Nm)
M5	1/6 turn with a tightening tool after first tightening by hand
Rc, NPT 1/8	0.8 to 1.0

3. Use of metal fittings

Do not use metal fittings for piping on taper threads made of resin, as this may cause damage to the threads.

LVA PPS body ported tightening torque for fittings.

Size	Breaking torque	Tightening torque (Nm)	Guideline for tightening torque (Number of turns)
LVA20	2 to 3	0.5 to 1	2 to 3 turns
LVA30	6 to 8	2 to 3	3 to 4 turns
LVA40	11 to 14	5 to 7	3 to 4 turns
LVA50	18 to 20	8 to 10	3 to 4 turns

* Guideline for tightening torque

Number of turns when the fitting is screwed into the body with 2 to 3 windings of sealant tape applied to threaded portion of the piping.

The value may differ for types other than sealant type.

4. Use pilot ports and sensor (breathing) ports as indicated below.

	PA Port	PB Port	Sensor (breathing) port
N.C.	Pressure	Breathing	Breathing
N.O.	Breathing	Pressure	Breathing
Double acting	Pressure	Pressure	Breathing

In the case of N.C. and N.O. types, the port which does not receive operating pressure is released to atmosphere. When intake and exhaust directly from the valve is not desired due to problems with the ambient environment or scattering of dust, etc., install piping and perform intake and exhaust at a location which does not present a problem.

5. See page 17-5-38 regarding tubing connections.

Operating Air Supply

Warning

1. Use clean air.

Do not use compressed air which includes chemicals, synthetic oils containing organic solvents, salt, or corrosive gases, etc., as this may cause damage or malfunction.

VC

VDW

VQ

VX2

VX

VX3

VXA

VN

LVC

LVA

L VH

LVD

LVQ

LQ

LVN

TI/
TIL

PA

PAX

PB



Series LV

High Purity Chemical Valve Precautions 2

Be sure to read before handling.

Operating Environment

Warning

1. Do not use in a location having an explosive atmosphere.
2. Do not operate in locations where vibration or impact occurs.
3. Do not use in locations where radiated heat will be received from nearby heat sources.

Maintenance

Warning

1. Maintenance should be performed in accordance with the procedures in the instruction manual.

Incorrect handling can cause damage or malfunction of machinery and equipment, etc.

2. Before removing equipment or compressed air supply/exhaust devices, shut off the air and power supplies, and exhaust compressed air from the system.

Further, when restarting equipment after re-mounting or replacement, first confirm safety and then check the equipment for normal operation.

3. Perform work after removing residual chemicals and carefully replacing them with DI water or air, etc.
4. Do not disassemble the product. Products which have been disassembled cannot be guaranteed.

If disassembly is necessary, contact SMC.

5. In order to obtain optimum performance from valves, perform periodic inspections to confirm that there are no leaks from valves or fittings, etc.

Caution

1. Removal of drainage

Flush drainage from filters regularly.

Precautions on Usage

Warning

1. Operate within the ranges of the maximum operating pressure and back pressure.

Caution

1. When the diaphragm is made of PTFE

Please note that when the product is shipped from the factory, gases such as N₂ and air may leak from the valve at a rate of 1cm³/min (when pressurized).

2. When operated at a very low flow rate, the series LV□ with flow rate adjustment may vibrate, etc. depending on the operating conditions. Therefore, operate it after careful examination of the flow rate, pressure and piping conditions.
3. In the series LV□, water hammering may occur depending on the fluid pressure conditions. In most cases, improvement is possible by adjusting the pilot pressure with a speed controller, etc., but the flow rate, pressure and piping conditions should be reviewed.
4. To adjust the flow rate for the series LV□ with flow rate adjustment, open gradually starting from the fully closed condition. Opening is accomplished by turning the adjustment knob counter clockwise. Additionally, do not apply any unreasonable force to the adjustment handle when nearing a fully opened or closed state. This may result in deformation of the orifice sheet surface or damage to the threaded part of the adjustment handle. It is in the fully closed condition when the product is shipped from the factory.
5. After a long period of nonuse, perform a test run before beginning regular operation.
6. Since the LVC is packaged in a clean room use sufficient care in handling when opened.
7. Take extra care when setting the operating direction and when handling the lever of series LVH.