

Compact Guide Cylinder

Series MGC

ø20, ø25, ø32, ø40, ø50



How to Order

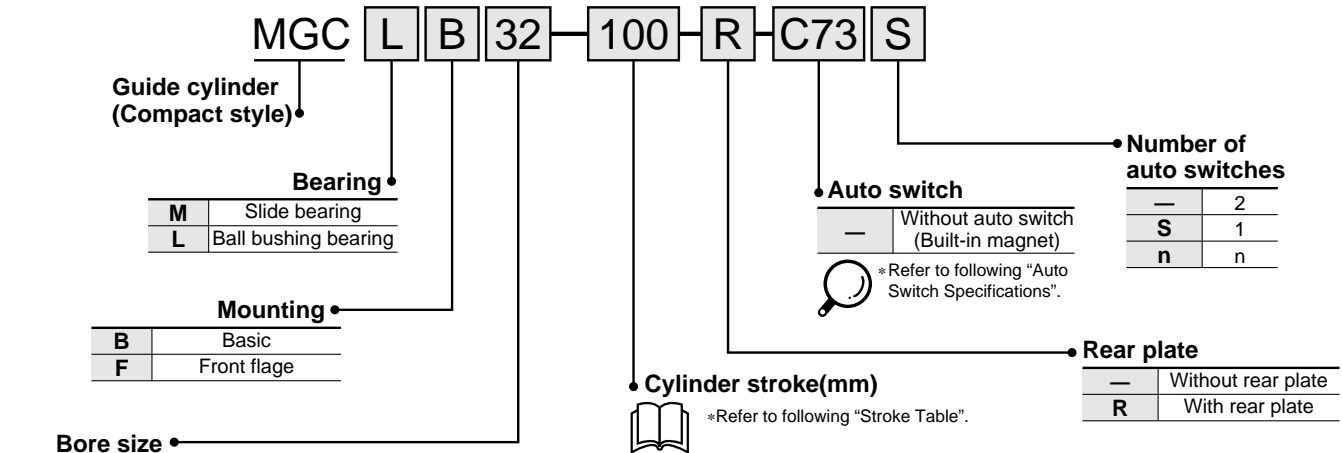

Bore size

20	20mm
25	25mm
32	32mm
40	40mm
50	50mm

Applicable Auto Switches/Refer to p.5.3-2 for further information on auto switch.

Style	Special function	Electrical entry	Indicator	Wiring (Output)	Load voltage		Auto switch model			Lead wire* (m)				Applicable load				
					DC	AC	Electrical entry direction		0.5 (—)	3 (L)	5 (Z)	— (N)						
							In-line	Perpendicular										
Reed switch	—	Grommet	Yes	3 wire(Equiv. NPN)	—	5V	—	C76	—	B76	●	●	—	—	IC			
								100V	C73	—	B73	●	●	●	—	—	Relay, PLC	
								12V	B53	—	—	●	●	●	—	—	PLC	
								100V, 200V	B54	—	—	●	●	—	—	—	—	
								200V or less	B64	—	—	●	●	—	—	—	—	
								5V, 12V	100V or less	C80	—	B80	●	●	—	—	IC	Relay
								12V	—	C73C	—	B73C	●	●	●	●	—	PLC
Solid state switch	Diagnostic indication (2 color)	Grommet	Yes	3 wire(NPN)	—	5V, 12V	—	H7A1	G59	G79	●	●	○	—	IC			
								3 wire(PNP)	H7A2	G5P	—	—	●	●	○	—	—	
								2 wire	H7B	K59	K79	●	●	○	—	—	—	
									H7C	—	K79C	●	●	●	●	—	—	
								3 wire(NPN)	H7NW	G59W	—	—	●	●	○	—	IC	
									H7PW	G5PW	—	—	●	●	○	—	—	
								3 wire(PNP)	H7BW	K59W	—	—	●	●	○	—	—	
									H7BA	G5BA	—	—	—	●	○	—	—	
								2 wire	G5NT	—	—	—	●	○	—	—	IC	
								3 wire(NPN)	H7NF	G59F	—	—	●	●	○	—	—	
4 wire(NPN)	H7LF	—	—	—	●	●	○	—	—									

*Lead wire length 0.5m..... — (Example) B80C 5m..... Z (Example) B80CZ
 3m..... Z (Example) B80CL —..... N (Example) B80CN
 *○: Manufactured upon receipt of order

Stroke

Model	Bearing	Bore size (mm)	Standard stroke (mm)	Long stroke (mm)
MGCM	Slide bearing	20	75, 100, 125, 150, 200	250, 300, 350, 400
		25	75, 100, 125, 150,	350, 400, 450, 500
		32		200, 250, 300
MGCL	Ball bushing bearing	40	75, 100, 125, 150,	350, 400, 450, 500, 600, 700, 800
		50		200, 250, 300
		—		350, 400, 450, 500, 600, 700, 800, 900, 1000

*Short stroke or intermediate stroke(except above stroke): Manufactured upon receipt of order

Compact Guide Cylinder *Series MGC*



Specifications

Model		MGC□□20	MGC□□25	MGC□□32	MGC□□40	MGC□□50
Base cylinder		CDGIBA20	CDGIBA25	CDGIBA32	CDGIBA40	CDGIBA50
Bore size (mm)		20	25	32	40	50
Action		Double acting				
Fluid		Air				
Proof pressure		1.5MPa				
Max. operating pressure		1.0MPa				
Min. operating pressure		0.15MPa (At horizontal non-load)				
Ambient and fluid temperature		-10 to +60°C				
Piston speed		50 to 750mm/s				
Cushion		Air cushion				
Lubrication		Non-lube				
Thread tolerance		JIS class 2				
Stroke tolerance		+1.9 +0.2 mm				
Performance of non-rotation (Expect for bending of guide rod)	Slide bearing	±0.07°	±0.06°	±0.06°	±0.05°	±0.04°
	Ball bush bearing	±0.06°	±0.05°	±0.04°	±0.04°	±0.04°
Port size		M5 X 0.8		Rc(PT)1/8		Rc(PT)1/4

- CL
- MLGC
- CNA
- CB
- CV/MVG
- CXW
- CXS
- CXT
- MX
- MXU
- MXS
- MXQ
- MXF
- MXW
- MPX
- MG
- MGP
- MGQ
- MGG
- MGC
- MGF
- CY1
- MY1

JIS Symbol

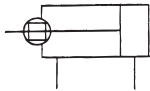

Made to Order

Refer to p.5.4-1 regarding made to order of series MGC.

Allowable Kinetic Energy by Air Cushion Mechanism

R: Rod side, H: Head side

Bore size (mm)	Effective cushion length (mm)	Absorbable kinetic energy (J)
20	R: 7.0, H: 7.5	R: 0.35, H: 0.42
25	R: 7.0, H: 7.5	R: 0.56, H: 0.65
32	7.5	0.91
40	8.7	1.8
50	11.8	3.4

High kinetic energy generated by large loads and high speed operations can be absorbed by compressing air at the stroke end thus preventing shock and vibration being transmitted to the machine. If the kinetic energy is within the range of the table above, the life of the cushion packing can be expected to exceed a million operations. The air cushion has not been designed to control the piston speed in the end regions of the stroke.

The load kinetic energy can be obtained by the following equation:

$$E_k = \frac{M}{2} v^2$$

E_k : Kinetic energy (J)
 M : Weight of load (kg)+Weight of moving section (kg)
 v : Piston speed (m/s)



Theoretical Force

Unit: N

Bore size (mm)	Piston rod dia. (mm)	Operation direction	Piston area (mm ²)	Operating pressure (MPa)								
				0.2	0.3	0.4	0.5	0.6	0.7	0.8	0.9	1.0
20	8	OUT	314	62.8	94.2	126	157	188	220	251	283	314
		IN	264	52.8	79.2	106	132	158	185	211	238	264
25	10	OUT	491	98.2	147	196	246	295	344	393	442	491
		IN	412	82.4	124	165	206	247	288	330	371	412
32	12	OUT	804	161	241	322	402	482	563	643	724	804
		IN	691	138	207	276	346	415	484	553	622	691
40	16	OUT	1260	252	378	504	630	756	882	1010	1130	1260
		IN	1060	212	318	424	530	636	742	848	954	1060
50	20	OUT	1960	392	588	784	980	1180	1370	1570	1760	1960
		IN	1650	330	495	660	825	990	1160	1320	1490	1650

Note) Theoretical force(N)=Pressure(MPa) X Position area(mm²)

Series MGC

Weight

Bore size (mm)		20	25	32	40	50
Standard weight	Basic	1.25	1.85	2.46	4.03	7.47
	Front flange	1.72	2.41	3.08	5.19	8.74
Bearing weight	Slide bearing	0.2	0.28	0.44	0.6	1.32
	Ball bushing bearing	0.13	0.17	0.28	0.35	0.88
Additional weight with rear plate		0.19	0.24	0.33	0.55	1.02
Additional weight per 50 stroke		0.14	0.17	0.25	0.4	0.61
Additional weight with long stroke		0.01	0.01	0.02	0.03	0.06

Calculation example:

MGCLB32-500-R

(Basic/Ball bushing bearing, Rear plate, ø32/500st)

- Basic weight.....2.46 (Basic type)
 - Bearing weight.....0.28 (Ball bush bearing)
 - Additional weight with rear plate.....0.33
 - Additional weight for stroke0.25/50 stroke
 - Stroke.....500 stroke
 - Additional weight for long stroke.....0.02
- 2.46+0.28+0.33+0.25 X 500/50+0.02=5.59kg

Weight (Moving Parts)

Bore size (mm)		20	25	32	40	50
Weight of moving parts		0.36	0.57	0.75	1.3	2.64
Additional weight per 50 stroke		0.19	0.24	0.33	0.55	1.02
Additional weight with rear plate		0.09	0.11	0.16	0.25	0.39

Calculation example:

MGCLB32-500-R

- Standard weight of moving parts.....0.75
 - Additional weight with rear plate.....0.33
 - Additional weight for stroke.....0.16/50 stroke
 - Stroke.....500 stroke
- 0.75+0.33+0.16 X 500/50=2.68kg

⚠ Precautions

Be sure to read before handling. Refer to p.0-39 to 0-46 for Safety Instructions and common precautions.

Handling

⚠ Warning

- ① Installing a protective cover (In case of rear plate)
During mounting, handling and operation, the rear plate makes reciprocating movements. Therefore, pay careful attention not to insert your hand, etc., between the cylinder and the rear plate. When you are going to fit this product to the outside of your equipment, take preventative measures such as installing a protective cover.

Example of installing protective cover

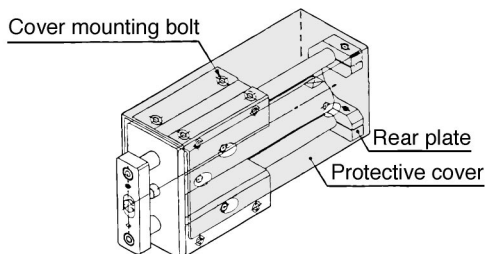
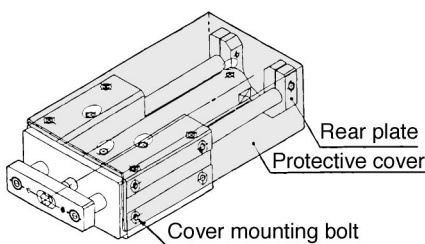

Mounting/Adjustment

⚠ Caution

- ① Pay attention so that no scratch or dent will be given to the slide part of the guide rod.
Otherwise, faulty operation and dropping of durability may occur.
- ② When fitting the guide body, use the guide body which has high flatness of the fitting surface. If the guide rod has twisted, operation resistance will become abnormally higher and the bearing will wear at an early stage, thereby resulting in poor performance.
- ③ Allow an ample space around the cylinder so that no obstruction will occur for checking and maintenance.
- ④ Do not adjust the rod stroke by moving the rear plates, as doing so will cause the rear plates to come into direct contact with the guide body or the bracket mounting bolt. The resulting impact cannot be absorbed easily, the stroke position cannot be maintained, and faulty operation may result.
- ⑤ Lubrication
The bearing can be used in an oilless state, but when you are going to oil the bearings, do so by using a ball-cup so that no foreign matter will be mixed.
For the grease, we recommended using high-quality lithium soap-based grease No. 2.

Allowable Eccentric Load

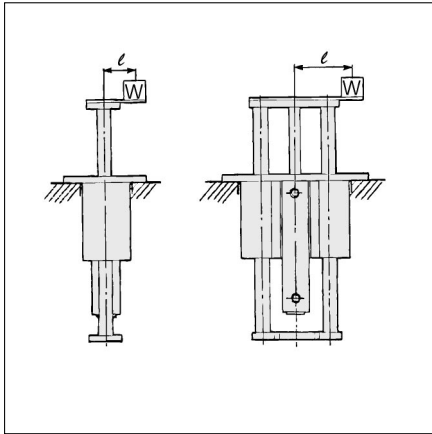

Slide bearing/ MGCM □□-Stroke-R

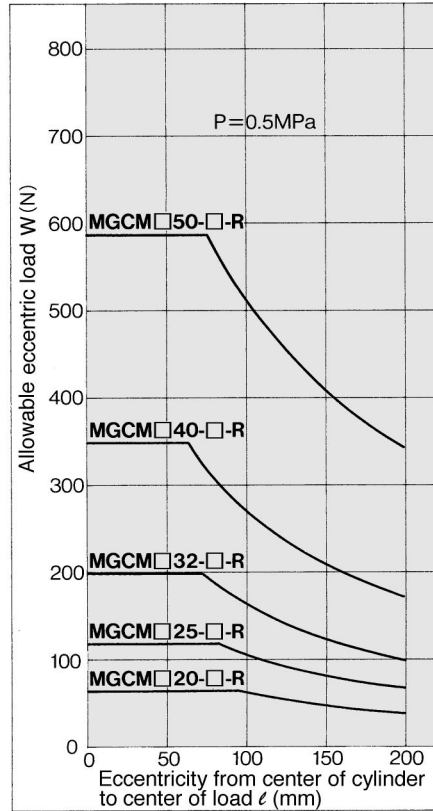

Arrange so that maximum load will be 40% for theoretical force of $\phi 20$, 50% for $\phi 32$, 55% for $\phi 40$ and 60% or less for $\phi 50$, respectively.

Ball bushing bearing/ MGCL □□-Stroke-R

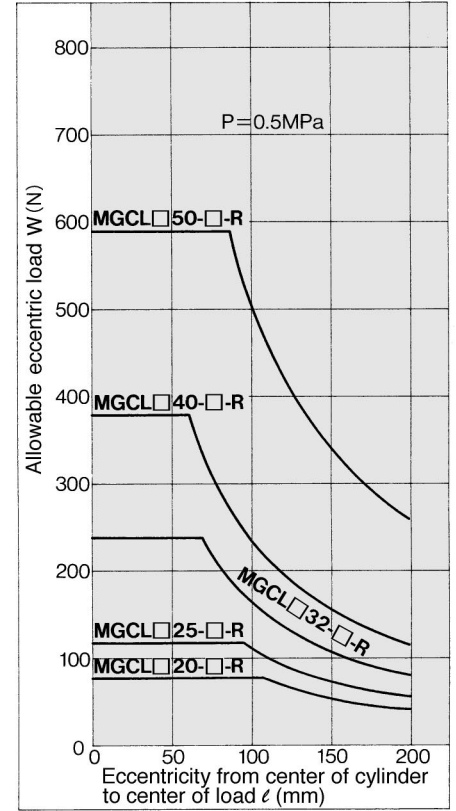

Arrange so that maximum load will be 40% for theoretical force of $\phi 20$, 50% for $\phi 32$, 55% for $\phi 40$ and 60% or less for $\phi 50$, respectively.

Air-hydro

Low hydraulic pressure cylinder under 1.0MPa

Through the concurrent use of a CC Series air-hydro unit, it becomes possible to operate at a constant or low speed or to effect an intermediate stop, just like a hydraulic unit, while using pneumatic equipment such as a valve.

MGCH **Bearing** **Mounting** **Bore size** **Stroke** **Rear plate**
 ↓
 Air-hydro style

Specifications

Bore size (mm)	$\phi 20, \phi 25, \phi 32, \phi 40, \phi 50$
Action	Double acting
Fluid	Turbine oil
Proof pressure	1.5MPa
Max. operating pressure	1.0MPa
Min. operating pressure	0.18MPa (At horizontal non-load)
Piston speed	15 to 300mm/s
Cushion	—
Ambient and fluid temp	+5 to +60°C
Thread tolerance	JIS class 2
Stroke tolerance	+1.9mm +0.2
Mounting	Basic Front flange

* Refer to p.3.20-3 regarding other specifications.

* Possible to mount an auto switch.

Copper Free

To prevent the generation of copper ions, in order to eliminate any influences of copper ions or fluororesins on color CRTs, copper materials have been nickel plated or replaced with copper-free materials.

20-MGC **Bearing** **Mounting** **Bore size** **Stroke** **Rear plate**

↓
Copper free

Specifications

Bore size (mm)	$\phi 20, \phi 25, \phi 32, \phi 40, \phi 50$
Action	Double acting
Fluid	Air
Max. operating pressure	1.0MPa
Min. operating pressure	0.15MPa (At horizontal non-load)
Cushion	Air cushion
Piston speed	50 to 750mm/s
Mounting	Basic Front flange

* Refer to p.3.20-3 regarding other specifications and p.3.20-10 and 3.20-11 regarding dimensions.

* Possible to mount an auto switch.

CL
MLGC
CNA
CB
CV/MVG
CXW
CXS
CXT
MX
MXU
MXS
MXQ
MXF
MXW
MXP
MG
MGP
MGQ
MGG
MGC
MGF
CY1
MY1

Series MGC

Allowable Tip Load and Deflection Slide bearing

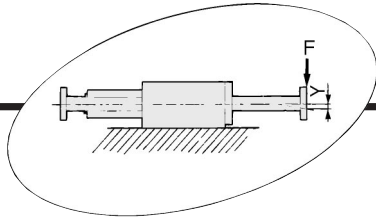

MGCM□20-Stroke-R

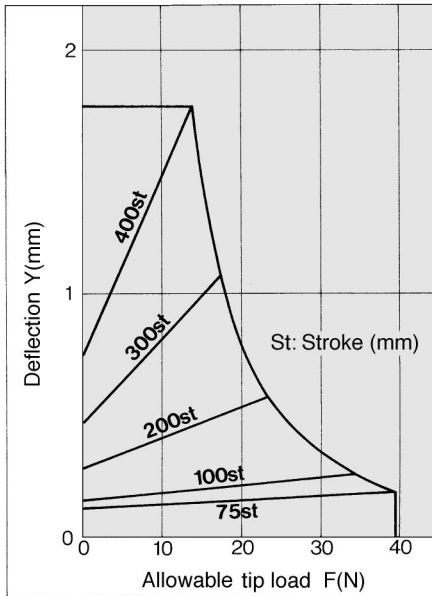

MGCM□25-Stroke-R

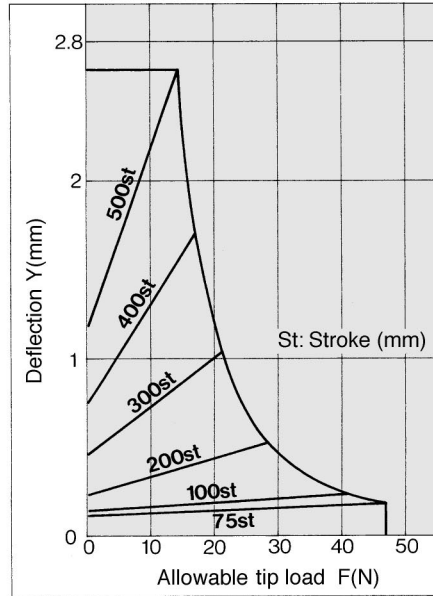

MGCM□32-Stroke-R

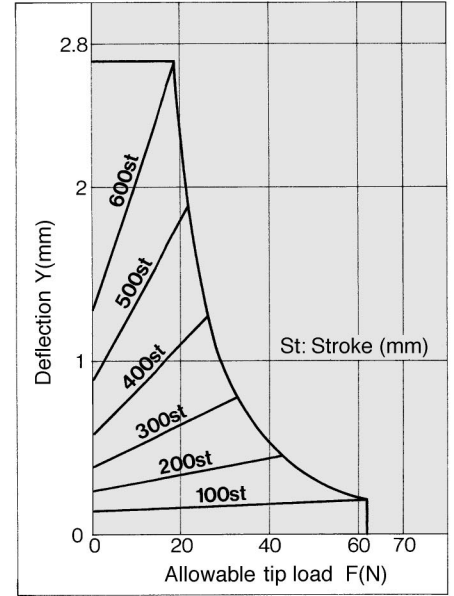

MGCM□40-Stroke-R

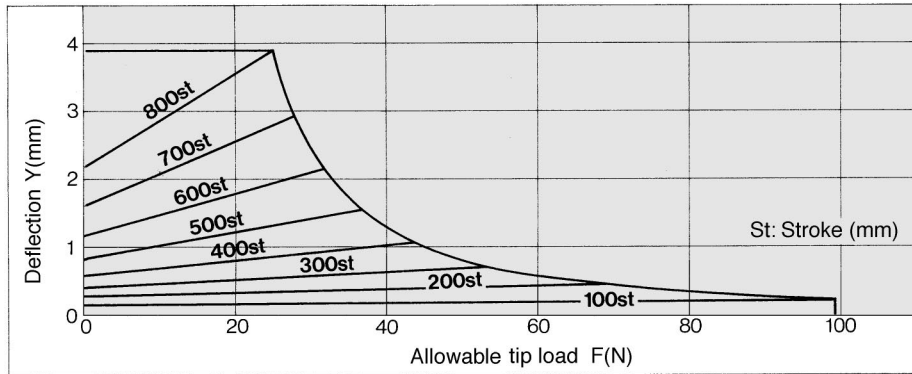

MGCM□50-Stroke-R

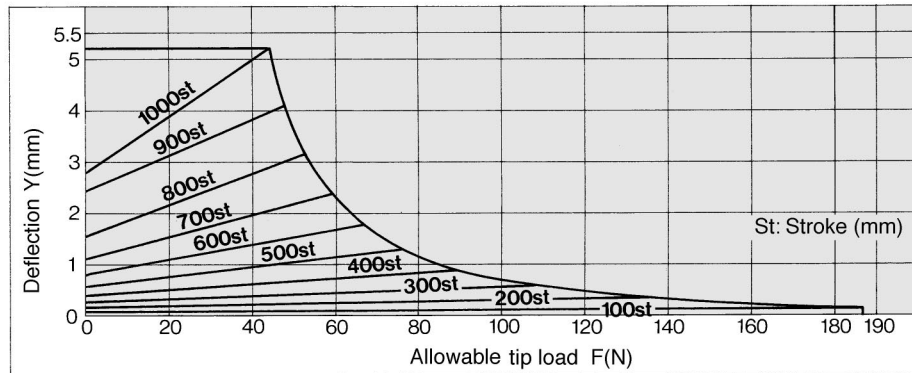

Allowable Tip Load and Deflection
Ball bushing bearing

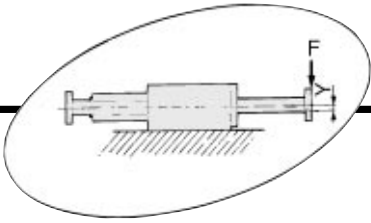

MGCL□20-Stroke-R

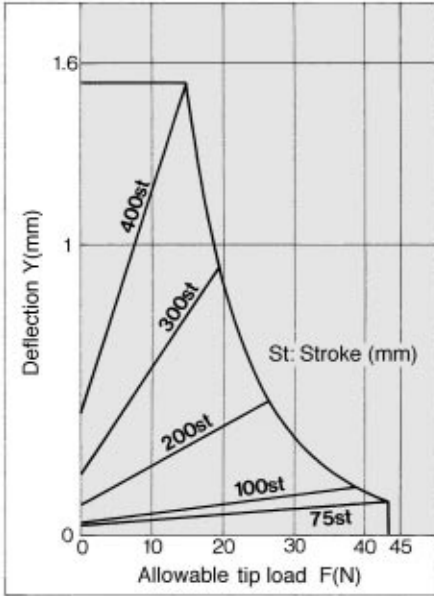

MGCL□25-Stroke-R

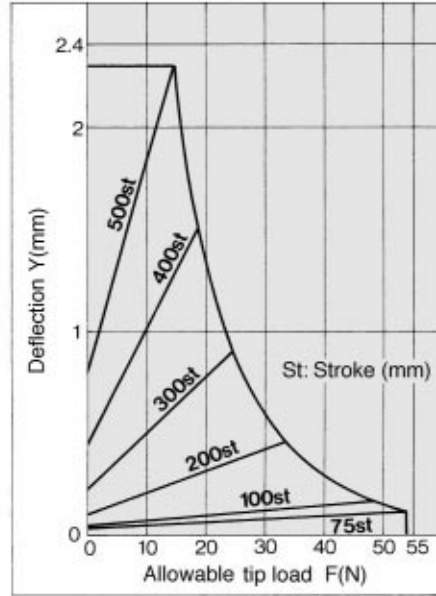

MGCL□32-Stroke-R

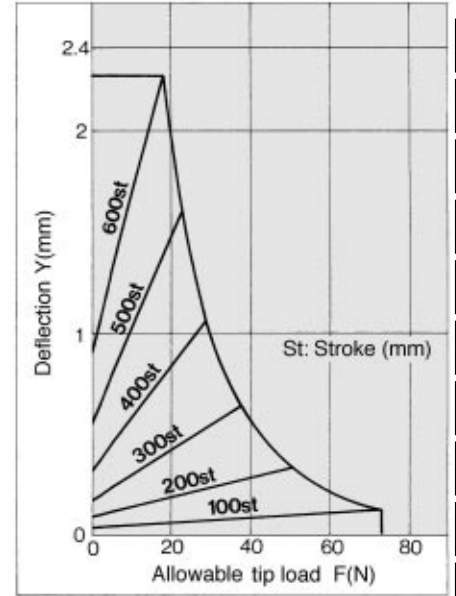

MGCL□40-Stroke-R

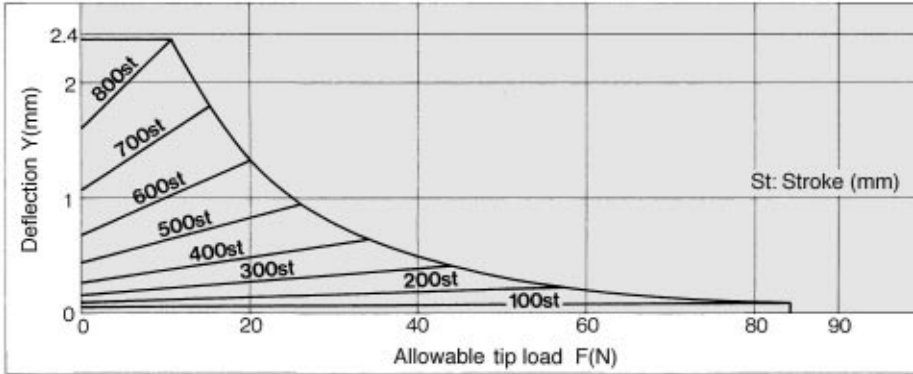

MGCL□50-Stroke-R

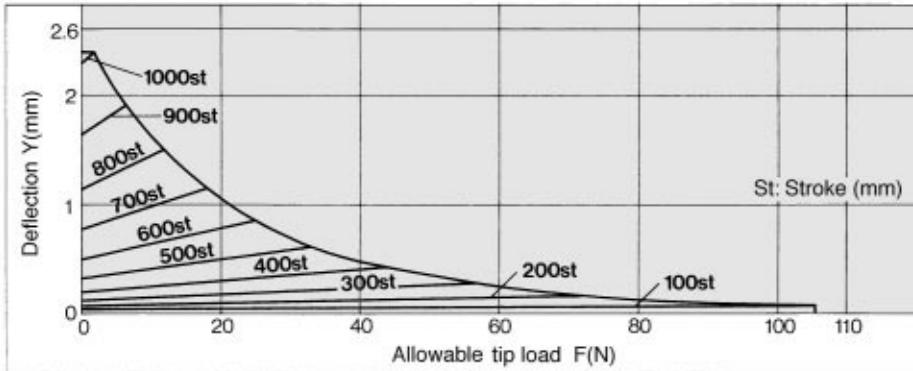

- CL
- MLGC
- CNA
- CB
- CV/MVG
- CXW
- CXS
- CXT
- MX
- MXU
- MXS
- MXQ
- MXF
- MXW
- MXP
- MG
- MGP
- MGQ
- MGG
- MGC**
- MGF
- CY1
- MY1

Series MGC

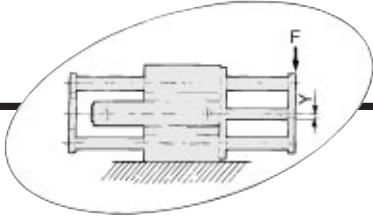

Allowable Tip Load and Deflection Slide bearing

MGCM □ 20-Stroke-R

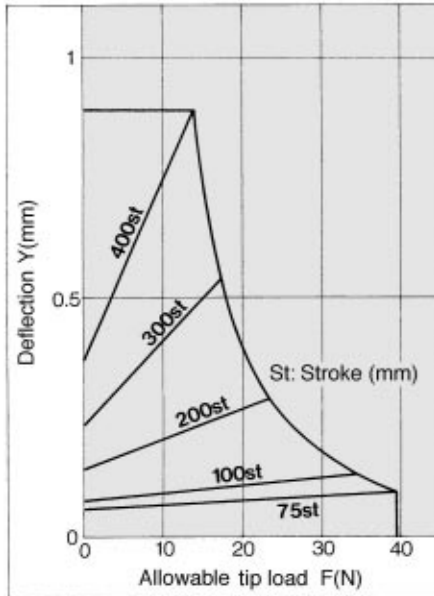

MGCM □ 25-Stroke-R

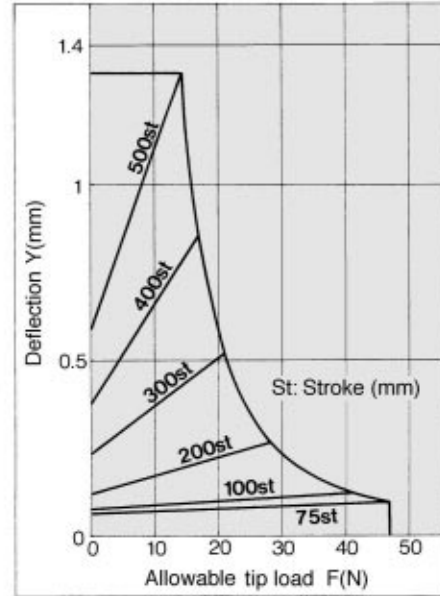

MGCM □ 32-Stroke-R

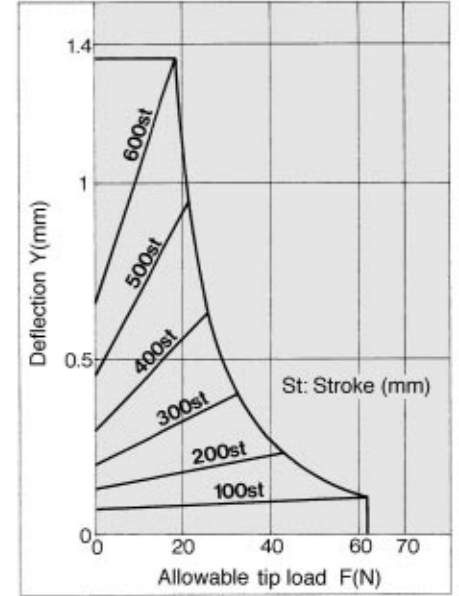

MGCM □ 40-Stroke-R

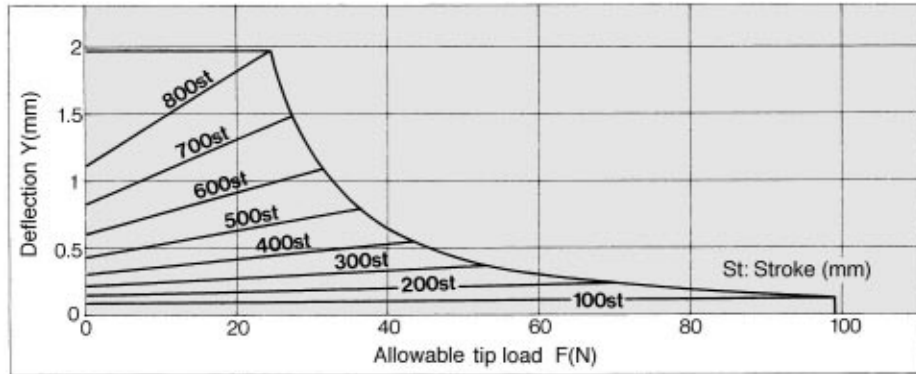

MGCM □ 50-Stroke-R

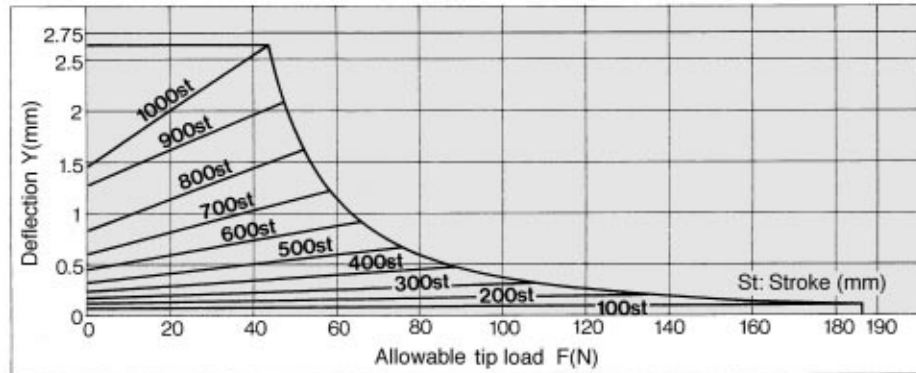

**Allowable Tip Load and Deflection
Ball bushing bearing**

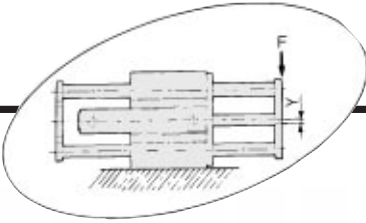

MGCL□20-Stroke-R

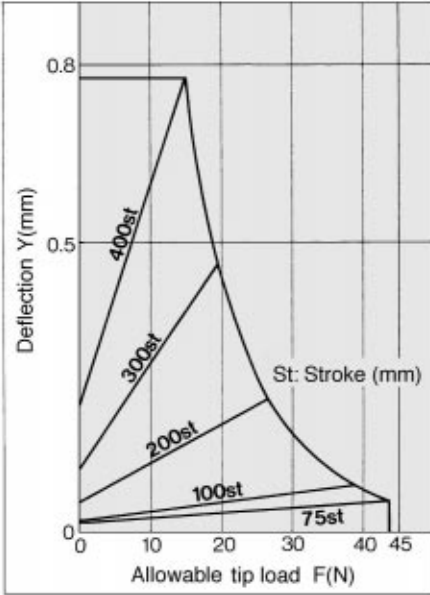

MGCL□25-Stroke-R

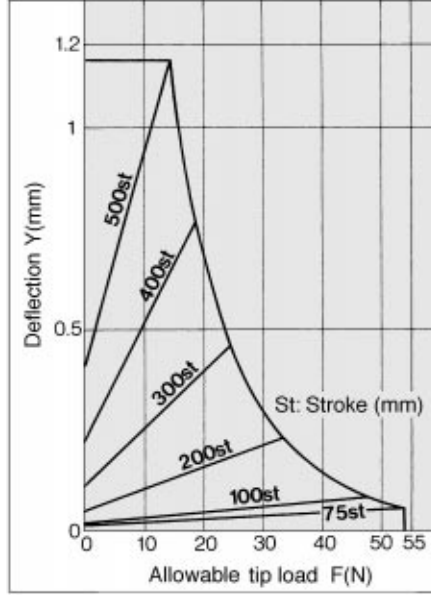

MGCL□32-Stroke-R

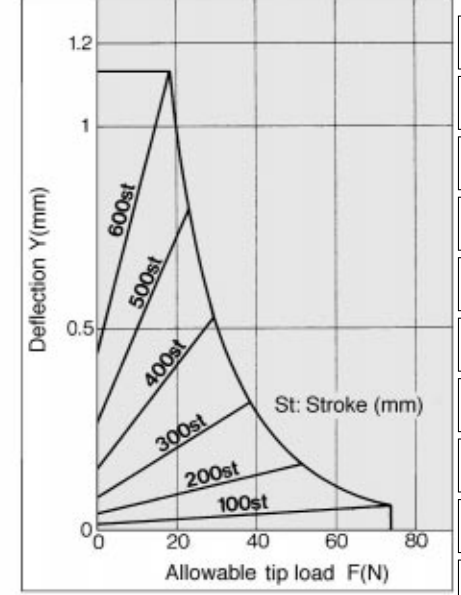

MGCL□40-Stroke-R

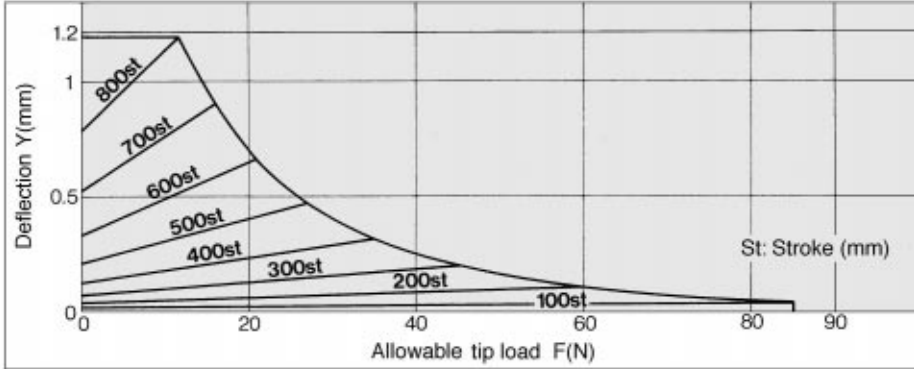

MGCL□50-Stroke-R

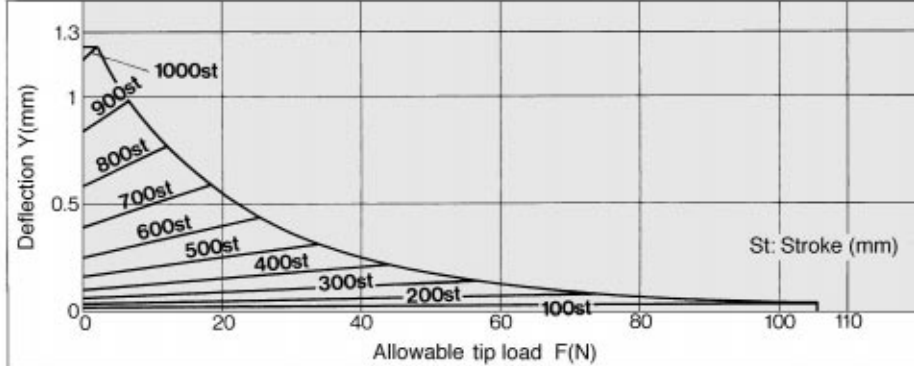

- CL
- MLGC
- CNA
- CB
- CV/MVG
- CXW
- CXS
- CXT
- MX
- MXU
- MXS
- MXQ
- MXF
- MXW
- MXP
- MG
- MGP
- MGQ
- MGG
- MGC**
- MGF
- CY1
- MY1

Series MGC



Basic/With Rear Plate

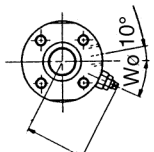
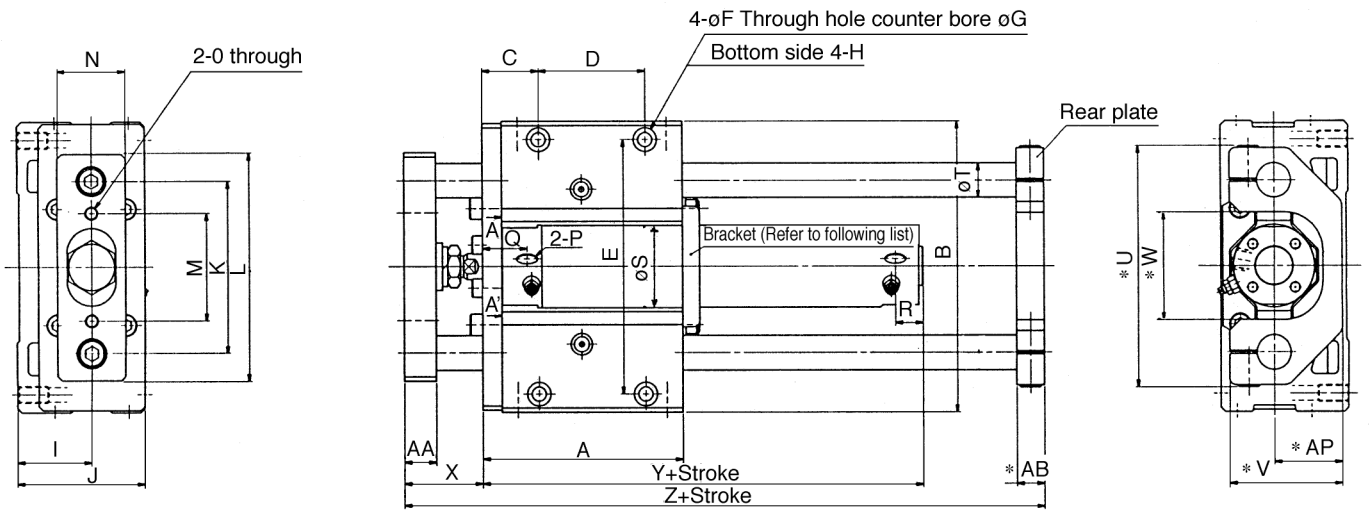

WH(Max.)

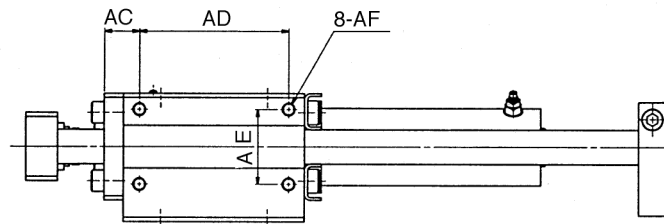

A-A' View drawing

Bore (mm)	Stroke range (mm)	A	AA	AB	AC	AD	AE	AF	AP	B	C	D	E	F	G	H
20	75, 100, 125, 150, 200	84	11	13	15.5	62	25	M5 X 0.8Depth10	22	106	24	45	90	5.6	9.5Depth6	M6 X 1Depth10
25	75, 100 125, 150 200, 250 300	89	15	13	16.5	65	30	M6 X 1Depth12	27	120	26.5	45	103	6.8	11Depth8	M8 X 1.25Depth14
32		94	15	13	16.5	70	35	M6 X 1Depth12	32	135	26.5	50	118	6.8	11Depth8	M8 X 1.25Depth14
40		107	18	16	22	75	40	M8 X 1.25Depth16	37	160	34.5	50	140	8.6	14Depth10	M10 X 1.5Depth18
50		142	23	19	22	110	45	M10 X 1.5Depth20	42	194	37	80	170	10.5	17Depth12	M12 X 1.75Depth21

Bore (mm)	I	J	K	L	M	N	O	P	Q	R	S	T	U	V	W	WH	Wθ	X	Y	Z
20	25	44	60	80	38	25	M6 X 1	M5 X 0.8	21	12	26	12	86	40	36	23	30°	30	80	140
25	30	52	70	95	46	32	M6 X 1	M5 X 0.8	21	12	31	13	98	47	44	25	30°	37	80	153
32	35	60	80	105	50	32	M6 X 1	Rc(PT)1/8	21	12	38	16	112	53	50	28.5	25°	37	82	161
40	40	70	95	125	60	38	M8 X 1.25	Rc(PT)1/8	25	12	47	20	132	63	60	33	20°	44	92	188
50	45	82.5	115	150	75	50	M8 X 1.25	Rc(PT)1/8	26	14	58	25	162	73	70	40.5	20°	55	104	241

Without rear plate

Long stroke

Bore (mm)	Z
20	119
25	131
32	136
40	156
50	202

Bore (mm)	Stroke range (mm)	R	Y
20	250 to 400	14	88
25	350 to 500	14	88
32	350 to 600	14	90
40	350 to 800	15	101
50	350 to 1000	16	116

Bracket mounting stroke

Bore (mm)	Bracket mounting stroke
20	100st or more
25	125st or more
32	150st or more
40	200st or more
50	250st or more

Note) Dimensions with a * mark is irrelevant to models without a rear plate.



With auto switch

MGCB [Bore size]SMGC [Bore size] #1(#1+#4)

Compact Guide Cylinder *Series MGC*



Front Face Mounting Flange/With Rear Plate

MGC□F□-□-R

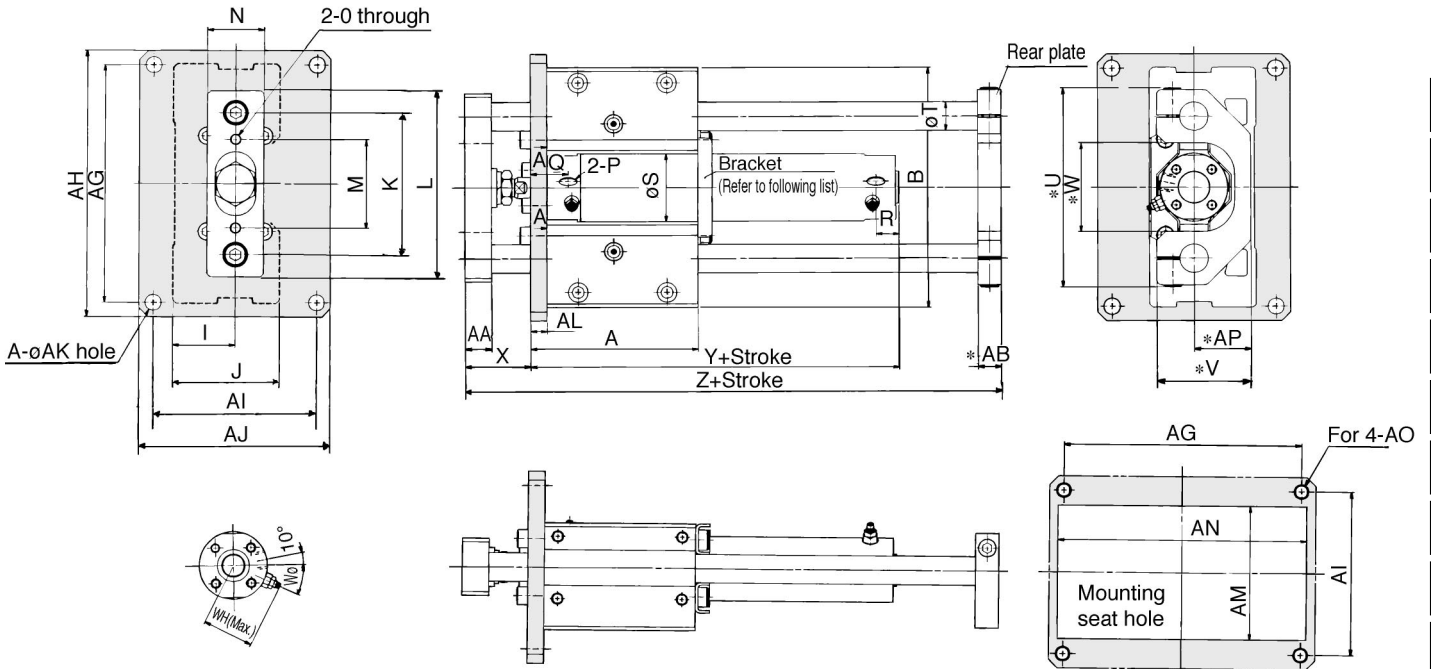

A-A' View drawing

Mounting seat dimension

- CL
- MLGC
- CNA
- CB
- CV/MVG
- CXW
- CXS
- CXT
- MX
- MXU
- MXS
- MXQ
- MXF
- MXW
- MPX
- MG
- MGP
- MGQ
- MGG
- MGC**
- MGF
- CY1
- MY1

Bore (mm)	Stroke range (mm)	A	AA	AB	AG	AH	AI	AJ	AK	AL	AM	AN	AO	AP	B	I	J	K	L	M	N
20	75, 100, 125, 150, 200	84	11	13	105	120	75	90	6.6	9	55	110	M6	22	106	25	44	60	80	38	25
25	75, 100 125, 150 200, 250 300	89	15	13	120	136	84	100	9	9	65	125	M8	27	120	30	52	70	95	46	32
32		94	15	13	134	150	92	108	9	9	75	140	M8	32	135	35	60	80	105	50	32
40		107	18	16	160	176	110	125	9	12	85	165	M8	37	160	40	70	95	125	60	38
50		142	23	19	190	210	115	135	11	12	95	200	M10	42	194	45	82.5	115	150	75	50

Bore (mm)	O	P	Q	R	S	T	U	V	W	WH	Wθ	X	Y	Z
20	M6 X 1	M5 X 0.8	21	12	26	12	86	40	36	23	30°	30	80	140
25	M6 X 1	M5 X 0.8	21	12	31	13	98	47	44	25	30°	37	80	153
32	M6 X 1	Rc(PT)1/8	21	12	38	16	112	53	50	28.5	25°	37	82	161
40	M8 X 1.25	Rc(PT)1/8	25	12	47	20	132	63	60	33	20°	44	92	188
50	M8 X 1.25	Rc(PT)1/4	26	14	58	25	162	73	70	40.5	20°	55	104	241

Without rear plate

Bore (mm)	Z
20	119
25	131
32	136
40	156
50	202

Long stroke

Bore (mm)	stroke range (mm)	R	Y
20	250 to 400	14	88
25	350 to 500	14	88
32	350 to 600	14	90
40	350 to 800	15	101
50	350 to 1000	16	116

Bracket mounting stroke

Bore (mm)	Bracket mounting stroke
20	100st or more
25	125st or more
32	150st or more
40	200st or more
50	250st or more

Note) Dimensions with a * mark is irrelevant to models without a rear plate



With auto switch

MGC□F□ Bore sizeSMGC Bore size #2(#1+#2+#4)

Series MGC

Construction

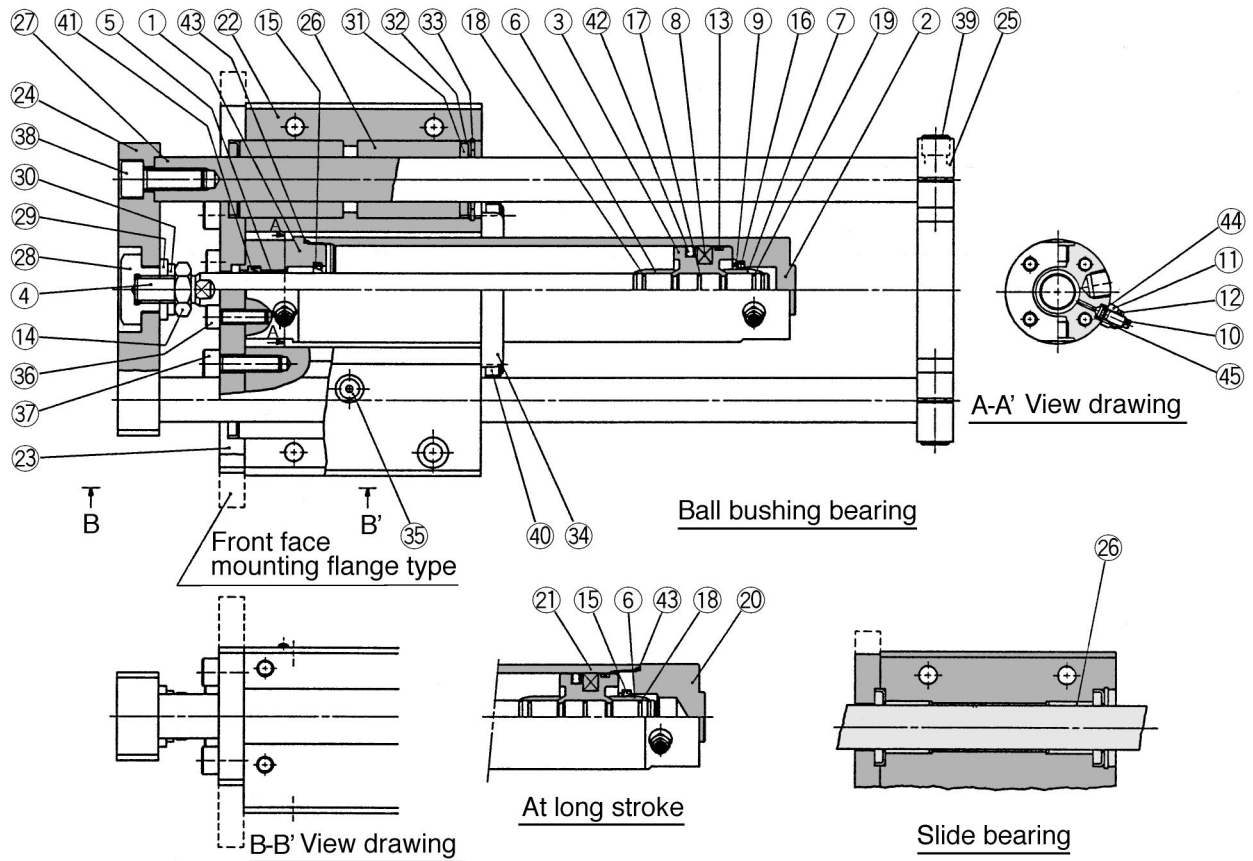

Component Parts

No.	Description	Material	Note
①	Rod cover	Aluminum alloy	Hard white anodized
②	Tube cover	Aluminum alloy	Hard white anodized
③	Piston	Aluminum alloy	Chromated
④	Piston rod	Carbon steel	Hard chrome plated $\phi 20, \phi 25$: stainless steel
⑤	Bush	Oil impregnated sintered alloy	$\phi 40$ or more: Lead-bronze cast
⑥	Cushion ring A	Brass	
⑦	Cushion ring B	Brass	Note 1)
⑧	Rubber magnet	Synthetic rubber	
⑨	Packing retainer	Rolled steel	Nickel plated (Nothing for long stroke)
⑩	Cushion valve	Rolled steel	Electroless nickel plated
⑪	Valve retainer	Rolled steel	Electroless nickel plated
⑫	Lock nut	Rolled steel	Nickel plated
⑬	Wear ring	Resin	
⑭	Rod end nut	Rolled steel	Nickel plated
⑮	Cushion seal A	Urethane	
⑯	Cushion seal B	Urethane	Note 2)
⑰	Piston gasket	NBR	
⑱	Cushion ring gasket A	NBR	
⑲	Cushion ring gasket B	NBR	W/ cushion ring gasket A: Except standard $\phi 20$ and $\phi 25$
⑳	Head cover	Aluminum alloy	Hard white anodized For long stroke
㉑	Cylinder tube	Aluminum alloy	Hard anodized
㉒	Guide body	Aluminum alloy	White anodized
㉓	Small flange	Rolled steel	Matt nickel plated For basic style
㉓	Large flange		
㉔	Front plate	Rolled steel	Matt nickel plated
㉕	Rear plate	Cast iron	Matt nickel plated

Note 1) Common with cushion ring A: Except standard $\phi 20$ and $\phi 25$
 Note 2) Common with cushion packing A: Except standard $\phi 20$ and $\phi 25$

Component Parts

No.	Description	Material	Note
㉖	Slide bearing	Special friction material	Slide bearing
㉖	Ball bushing bearing	—	Ball bushing bearing
㉗	Guide rod	Carbon steel	Hard chrome plated Slide bearing
㉗		Hi-carbon chrome bearing steel	Quenched, Hard chromium plated Ball bushing bearing
㉘	End bracket	Carbon steel	Matt nickel plated
㉙	Washer	Rolled steel	Nickel plated
㉚	Spring washer	Stell wire	Nickel plated
㉛	Felt	Felt	
㉜	Holder	Stainless steel	
㉝	For hole C retaining ring	Carbon tool steel	Nickel plated
㉞	Bracket	Stainless steel	
㉟	Ball in cup	—	Nickel plated
㊱	Hex. socket head cap screw	Chrome molybdenum steel	Nickel plated Cylinder mounting
㊲	Hex. socket head cap screw	Chrome molybdenum steel	Nickel plated Small/large flange mounting
㊳	Hex. socket head cap screw	Chrome molybdenum steel	Nickel plated Front plate mounting
㊴	Hex. socket head cap screw	Chrome molybdenum steel	Nickel plated Rear plate mounting
㊵	Hex. socket head cap screw	Chrome molybdenum steel	Nickel plated Bracket mounting
㊶	Rod seal	NBR	
㊷	Piston seal	NBR	
㊸	Tube gasket	NBR	
㊹	Valve seal	NBR	
㊺	Gasket for valve retainer	NBR	

Replacement Parts: Seal Kits

Bore size(mm)	Kit No.	Contents
20	CGIA20-PS	Set of above ④①, ④②, ④③, ④④ and ④⑤.
25	CGIA25-PS	
32	CGIA32-PS	
40	CGIA40-PS	
50	CGIA50-PS	

Seal kit includes rod seal ④①, piston seal ④②, tube gasket ④③, valve seal ④④ and gasket for valve retainer ④⑤. Order a packing set according to applicable bore size.

Auto Switch Specifications



Refer to p.5.3-2 for detailed information of auto switch.



Applicable Auto Switch

Bore size (mm)	Auto switch model	Electrical entry (Function)	Page	
20, 25 32, 40 50	Reed switch	D-B5, B6	Grommet	5.3-10
		D-B7, B8	Grommet	*
		D-B73C, B80C	Connector	*
		D-C7, C8	Grommet	5.3-9
		D-C73C, C80C	Connector	5.3-11
	Solid state switch	D-B59W	Grommet (2 color indication)	5.3-25
		D-G5, K5	Grommet	5.3-30
		D-G5NTL	Grommet (with timer)	5.3-59
		D-G7, K7	Grommet	*
		D-K79C	Connector	*
		D-H7	Grommet	5.3-29
		D-H7C	Connector	5.3-31
		D-G5 W, K59W	Grommet (2 color)	5.3-43
		D-G5BAL	Grommet (2 color, water resistant)	5.3-56
		D-G59F	Grommet (2 color, with diagnostic output)	5.3-51
		D-H7□W	Grommet (2 color)	5.3-42
		D-H7BAL	Grommet (2 color, water resistant)	5.3-55
		D-H7□F	Grommet (2 color, with diagnostic output)	5.3-49

* Contact SMC for detailed information of D-B7/B8 and D-G5/K7.

⚠ Precautions

Be sure to read before handling. Refer to p.0-44 to 0-46 for common precautions of auto switch.

- CL
- MLGC
- CNA
- CB
- CV/MVG
- CXW
- CXS
- CXT
- MX
- MXU
- MXS
- MXQ
- MXF
- MXW
- MPX
- MG
- MGP
- MGQ
- MGG
- MGC**
- MGF
- CY1
- MY1

Series MGC

Auto Switch Proper Mounting Position (Stroke End)

D-C7, C8
D-H7

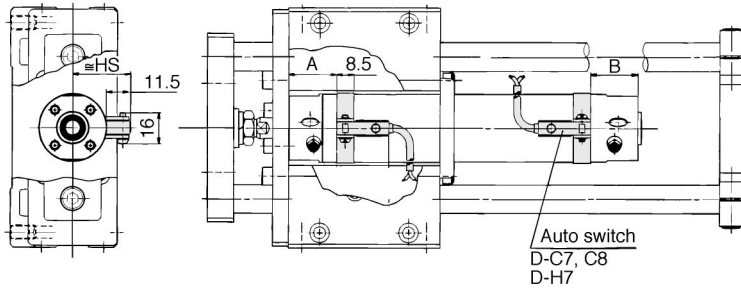

D-B5, B6
D-G5, K5

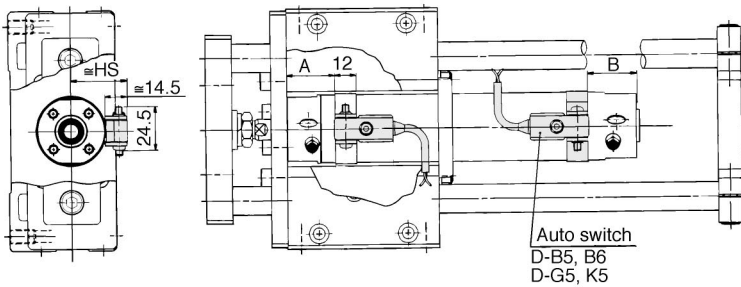

D-B7, B8
D-G7, K7

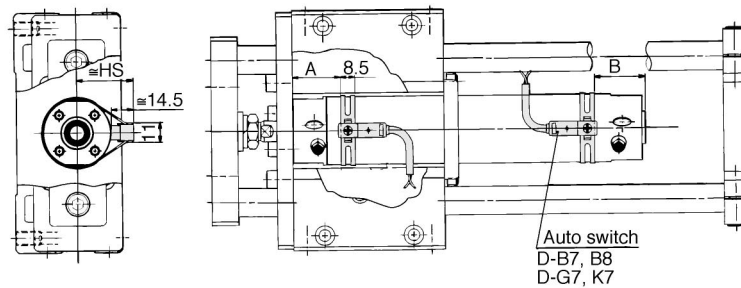

Auto Switch Mounting Position

(mm)

Auto switch	D-B7, B8 D-B73C D-B80C D-G7, K7 D-K79C		D-C7, C8 D-C73C D-C80C		D-B5, B6 D-G5□W D-K59W D-G5BAL D-G59F		D-B59W		D-H7 D-H7C		D-H7□W D-H7□F D-H7BAL		D-G5 D-G5NTL	
	A	B	A	B	A	B	A	B	A	B	A	B	A	B
20	31	21.5 (29.5)	30	20.5 (28.5)	24	15 (22.5)	27	17.5 (25.5)	29	19.5 (27.5)	27.5	18 (26)	25.5	16 (24)
25	31	21.5 (29.5)	30	20.5 (28.5)	24	15 (22.5)	27	17.5 (25.5)	29	19.5 (27.5)	27.5	18 (26)	25.5	16 (24)
32	32	22.5 (30.5)	31	21.5 (29.5)	25	15.5 (23.5)	28	18.5 (26.5)	30	20.5 (28.5)	28.5	19 (27)	26.5	17 (25)
40	36.5	25 (34)	35.5	24 (33)	29.5	18 (27)	32.5	21 (30)	34.5	33 (32)	33	21.5 (30.5)	31	19.5 (28.5)
50	44	29.5 (41.5)	43	28.5 (40.5)	37	22.5 (34.5)	40	25.5 (37.5)	42	27.5 (39.5)	40.5	26 (38)	38.5	24 (36)

*(): For long stroke

Auto Switch Mounting Height

(mm)

D-C7, C8 D-H7 D-H7□W D-H7□F D-H7BAL	D-C73C D-C80C	D-B7, B8 D-B73C D-B80C D-G7, K7 D-K79C D-H7C D-G5NTL	D-G5, K5 D-G5□W D-K59W D-B5, B6 D-B59W D-G5BAL D-G59F
Hs	Hs	Hs	
24.5	27	27.5	
27	29.5	30	
30.5	33	33.5	
35	37.5	38	
40.5	43	43.5	