

# Compact Guide Cylinder Series *MGP*

ø12, ø16, ø20, ø25, ø32, ø40, ø50, ø63, ø80, ø100

## How to Order

**MGP** M 25   30 Y7BW  

**Bearing type**

M	Slide bearing
L	Ball bushing bearing

**Auto switch**

Nil	Without auto switch (Built-in magnet)
S	1 pc.

\* For the applicable auto switch model, refer to the table below.  
\* Auto switches are shipped together, (but not assembled). (Except D-P5DW)

**Bore size**

12	12 mm	40	40 mm
16	16 mm	50	50 mm
20	20 mm	63	63 mm
25	25 mm	80	80 mm
32	32 mm	100	100 mm

**Cylinder stroke (mm)**

Refer to "Standard Stroke" on page 8-19-9.

**Thread type**

Nil	M5 x 0.8
	Rc
N	NPT
TF	G

\* For bore sizes 12 and 16, M5 x 0.8 is only available.

### Applicable Auto Switch/Refer to page 8-30-1 for further information on auto switches.

Type	Special function	Electrical entry	Indicator/light	Wiring (Output)	Load voltage			Auto switch model		Lead wire length (m) *			Pre-wire connector	Applicable load	
					DC	AC	Perpendicular	In-line	0.5 (Nil)	3 (L)	5 (Z)	IC circuit		Relay, PLC	
															5 V
Reed switch	—	Grommet	Yes	3-wire (NPN equivalent)	—	5 V	—	—	Z76	●	●	—	—	IC circuit	—
				2-wire	24 V	12 V	100 V	—	Z73	●	●	●	—	—	Relay, PLC
Solid state switch	—	Grommet	Yes	3-wire (NPN)	24 V	5 V, 12 V	—	Y69A	Y59A	●	●	○	○	IC circuit	Relay, PLC
				3-wire (PNP)				Y7PV	Y7P	●	●	○	○	IC circuit	
				2-wire				Y69B	Y59B	●	●	○	○	—	
				3-wire (NPN)				Y7NWV	Y7NW	●	●	○	○	IC circuit	
				3-wire (PNP)				Y7PWV	Y7PW	●	●	○	○	IC circuit	
				2-wire				Y7BWV	Y7BW	●	●	○	○	—	
Water resistant (2-color indication)	—	12 V	—	—	Y7BA	—	●	○	○	—					
Magnetic field resistant (2-color indication)	—	—	—	—	P5DW	—	●	●	○	—					

\* Lead wire length symbols: 0.5 m..... Nil (Example) Y59A  
 3 m..... L (Example) Y59AL  
 5 m..... Z (Example) Y59AZ

\* Solid state switches marked with "○" are produced upon receipt of order.  
 \* D-P5DW type can be mounted only on bore sizes 40 to 100.

- Since there are other applicable auto switches than listed, refer to page 8-19-20 for details.
- For details about auto switches with pre-wire connector, refer to page 8-30-52.

## Specifications



Action	Double acting	
Fluid	Air	
Proof pressure	1.5 MPa	
Maximum operating pressure	1.0 MPa	
Minimum operating pressure	ø12, ø16	0.12 MPa
	ø20 to ø100	0.1 MPa
Ambient and fluid temperature	-10 to 60°C (No freezing)	
Piston speed <small>Note)</small>	ø12 to ø63	50 to 500 mm/s
	ø80, ø100	50 to 400 mm/s
Cushion	Rubber bumper on both ends	
Lubrication	Non-lube	
Stroke length tolerance	+1.5 0 mm	

Note) Maximum speed with no load.

Make a model selection, considering a load according to the graph on page 8-19-11.

## Standard Stroke

Bore size (mm)	Standard stroke (mm)
12, 16	10, 20, 30, 40, 50, 75, 100, 125, 150, 175, 200, 250
20, 25	20, 30, 40, 50, 75, 100, 125, 150, 175, 200, 250, 300, 350, 400
32 to 100	25, 50, 75, 100, 125, 150, 175, 200, 250, 300, 350, 400

## Manufacture of Intermediate Stroke

Description	Spacer installation type	Exclusive body (-XB10)		
	Spacers are installed in the standard stroke cylinder. • ø12 to 32: Available by the 1 mm stroke interval. • ø40 to 100: Available by the 5 mm stroke interval.	Dealing with the stroke by making an exclusive body. • All bore sizes are available by the 1 mm interval.		
Part no.	Refer to "How to Order" for the standard model numbers.	Suffix "-XB10" to the end of standard part number. <small>Note)</small>		
Applicable stroke (mm)	ø12, ø16	1 to 249	ø12, ø16	11 to 249
	ø20, ø25, ø32	1 to 399	ø20, ø25	21 to 399
	ø40 to ø100	5 to 395	ø32 to ø100	26 to 399
Example	Part no.: MGPM20-39 A spacer 1 mm in width is installed in a MGPM20-40. C dimension is 77 mm.	Part no.: MGPM20-39-XB10 Special body manufactured for 39 stroke. C dimension is 76 mm.		

Note) For details, refer to "Made to Order Specifications".

## Theoretical Output

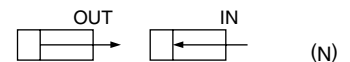

Bore size (mm)	Rod size (mm)	Operating direction	Piston area (mm <sup>2</sup> )	Operating pressure (MPa)										
				0.2	0.3	0.4	0.5	0.6	0.7	0.8	0.9	1.0		
12	6	OUT	113	23	34	45	57	68	79	90	102	113		
		IN	85	17	26	34	43	51	60	68	77	85		
16	8	OUT	201	40	60	80	101	121	141	161	181	201		
		IN	151	30	45	60	76	91	106	121	136	151		
20	10	OUT	314	63	94	126	157	188	220	251	283	314		
		IN	236	47	71	94	118	142	165	189	212	236		
25	12	OUT	491	98	147	196	246	295	344	393	442	491		
		IN	378	76	113	151	189	227	265	302	340	378		
32	16	OUT	804	161	241	322	402	482	563	643	724	804		
		IN	603	121	181	241	302	362	422	482	543	603		
40	16	OUT	1257	251	377	503	629	754	880	1006	1131	1257		
		IN	1056	211	317	422	528	634	739	845	950	1056		
50	20	OUT	1963	393	589	785	982	1178	1374	1570	1767	1963		
		IN	1649	330	495	660	825	990	1154	1319	1484	1649		
63	20	OUT	3117	623	935	1247	1559	1870	2182	2494	2805	3117		
		IN	2803	561	841	1121	1402	1682	1962	2242	2523	2803		
80	25	OUT	5027	1005	1508	2011	2514	3016	3519	4022	4524	5027		
		IN	4536	907	1361	1814	2268	2722	3175	3629	4082	4536		
100	30	OUT	7854	1571	2356	3142	3927	4712	5498	6283	7069	7854		
		IN	7147	1429	2144	2859	3574	4288	5003	5718	6432	7147		

Note) Theoretical output (N) = Pressure (MPa) x Piston area (mm<sup>2</sup>)



## Made to Order Specification (For details, refer to page 8-31-1.)

Symbol	Specifications
-XA□	Change of rod end shape
-XB6	Heat resistant cylinder (150°C)
-XB10	Intermediate stroke (Using exclusive body)
-XB13	Low speed cylinder (5 to 50 mm/s)
-XC4	With heavy duty scraper
-XC6	Piston rod and rod end nut made of stainless steel
-XC8	Adjustable stroke cylinder/Adjustable extension type
-XC9	Adjustable stroke cylinder/Adjustable extension type
-XC22	Fluoro rubber seals
-XC35	With coil scraper
-XC69	With shock absorber
-XC79	Machining tapped hole, drilled hole and pin hole additionally.
-X867	Lateral piping type (Change of plug position)

## Auto Switch Mounting Bracket Part No. for D-P5DW

Bore size (mm)	Mounting bracket part no.	Note
40, 50, 63, 80, 100	BMG1-040	Switch mounting bracket Hexagon socket head cap screw (M2.5 x 0.45 x 8φ) 2 pcs. Hexagon socket head cap screw (M3 x 0.5 x 16φ) 2 pcs. Spring washer (Nominal size 3)

MX□

MTS

MY□

CY□

MG□

CX□

D-

-X

20-

Data

# Series MGP

## Weight

### Slide Bearing: MGPM12 to 100

(kg)

Bore size (mm)	Model	Standard stroke (mm)															
		10	20	25	30	40	50	75	100	125	150	175	200	250	300	350	400
12	MGPM12	0.24	0.28	—	0.31	0.35	0.39	0.50	0.59	0.70	0.79	0.89	0.98	1.17	—	—	—
16	MGPM16	0.33	0.38	—	0.43	0.48	0.53	0.68	0.80	0.97	1.09	1.22	1.35	1.60	—	—	—
20	MGPM20	—	0.67	—	0.75	0.83	0.91	1.17	1.37	1.57	1.76	1.96	2.16	2.63	3.03	3.42	3.82
25	MGPM25	—	0.95	—	1.05	1.16	1.27	1.65	1.92	2.19	2.47	2.74	3.01	3.67	4.21	4.76	5.30
32	MGPM32	—	—	1.69	—	—	2.07	2.47	2.85	3.24	3.62	4.00	4.38	5.33	6.09	6.86	7.62
40	MGPM40	—	—	1.95	—	—	2.37	2.83	3.25	3.68	4.10	4.53	4.95	5.99	6.85	7.70	8.55
50	MGPM50	—	—	3.36	—	—	4.00	4.73	5.37	6.01	6.65	7.29	7.93	9.54	10.8	12.1	13.4
63	MGPM63	—	—	4.18	—	—	4.94	5.78	6.54	7.29	8.05	8.80	9.56	11.4	12.9	14.4	15.9
80	MGPM80	—	—	6.49	—	—	7.43	8.67	9.61	10.5	11.5	12.4	13.4	15.8	17.7	19.5	21.4
100	MGPM100	—	—	10.5	—	—	11.9	13.6	14.9	16.3	17.6	18.9	20.2	23.6	26.2	28.9	31.5

### Ball Bushing Bearing: MGPL12 to 100

(kg)

Bore size (mm)	Model	Standard stroke (mm)															
		10	20	25	30	40	50	75	100	125	150	175	200	250	300	350	400
12	MGPL12	0.24	0.27	—	0.30	0.35	0.39	0.47	0.56	0.66	0.74	0.83	0.91	1.08	—	—	—
16	MGPL16	0.34	0.39	—	0.43	0.51	0.56	0.67	0.79	0.93	1.04	1.16	1.28	1.50	—	—	—
20	MGPL20	—	0.70	—	0.77	0.89	0.97	1.14	1.31	1.52	1.69	1.87	2.04	2.42	2.77	3.12	3.47
25	MGPL25	—	0.98	—	1.07	1.25	1.34	1.57	1.81	2.08	2.31	2.54	2.77	3.27	3.74	4.20	4.66
32	MGPL32	—	—	1.54	—	—	1.85	2.30	2.62	2.99	3.31	3.62	3.94	4.63	5.26	5.89	6.52
40	MGPL40	—	—	1.79	—	—	2.15	2.64	3.00	3.42	3.78	4.14	4.50	5.28	6.00	6.72	7.44
50	MGPL50	—	—	3.11	—	—	3.66	4.41	4.96	5.60	6.15	6.70	7.25	8.48	9.57	10.7	11.8
63	MGPL63	—	—	3.93	—	—	4.59	5.46	6.12	6.88	7.54	8.21	8.87	10.3	11.7	13.0	14.3
80	MGPL80	—	—	6.25	—	—	7.39	8.69	9.51	10.3	11.1	12.0	12.8	14.7	16.3	18.0	19.6
100	MGPL100	—	—	9.89	—	—	11.6	13.4	14.5	15.7	16.9	18.1	19.3	21.9	24.2	26.6	28.9

### Allowable Rotational Torque of Plate

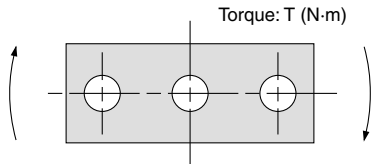

### Non-rotating Accuracy of Plate

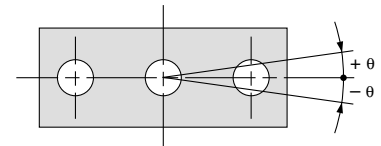

For non-rotating accuracy without load, use a value no more than the values in the table as a guide.

Bore size (mm)	Bearing type	Stroke (mm)															
		10	20	25	30	40	50	75	100	125	150	175	200	250	300	350	400
12	MGPM	0.39	0.32	—	0.27	0.24	0.21	0.43	0.36	0.31	0.27	0.24	0.22	0.19	—	—	—
	MGPL	0.61	0.45	—	0.35	0.58	0.50	0.37	0.29	0.24	0.20	0.18	0.16	0.12	—	—	—
16	MGPM	0.69	0.58	—	0.49	0.43	0.38	0.69	0.58	0.50	0.44	0.40	0.36	0.30	—	—	—
	MGPL	0.99	0.74	—	0.59	0.99	0.86	0.65	0.52	0.43	0.37	0.32	0.28	0.23	—	—	—
20	MGPM	—	1.05	—	0.93	0.83	0.75	1.88	1.63	1.44	1.28	1.16	1.06	0.90	0.78	0.69	0.62
	MGPL	—	1.26	—	1.03	2.17	1.94	1.52	1.25	1.34	1.17	1.03	0.93	0.76	0.65	0.56	0.49
25	MGPM	—	1.76	—	1.55	1.38	1.25	2.96	2.57	2.26	2.02	1.83	1.67	1.42	1.24	1.09	0.98
	MGPL	—	2.11	—	1.75	3.37	3.02	2.38	1.97	2.05	1.78	1.58	1.41	1.16	0.98	0.85	0.74
32	MGPM	—	—	6.35	—	—	5.13	5.69	4.97	4.42	3.98	3.61	3.31	2.84	2.48	2.20	1.98
	MGPL	—	—	5.95	—	—	4.89	5.11	4.51	6.34	5.79	5.33	4.93	4.29	3.78	3.38	3.04
40	MGPM	—	—	7.00	—	—	5.66	6.27	5.48	4.87	4.38	3.98	3.65	3.13	2.74	2.43	2.19
	MGPL	—	—	6.55	—	—	5.39	5.62	4.96	6.98	6.38	5.87	5.43	4.72	4.16	3.71	3.35
50	MGPM	—	—	13.0	—	—	10.8	12.0	10.6	9.50	8.60	7.86	7.24	6.24	5.49	4.90	4.43
	MGPL	—	—	9.17	—	—	7.62	9.83	8.74	11.6	10.7	9.83	9.12	7.95	7.02	6.26	5.63
63	MGPM	—	—	14.7	—	—	12.1	13.5	11.9	10.7	9.69	8.86	8.16	7.04	6.19	5.52	4.99
	MGPL	—	—	10.2	—	—	8.48	11.0	9.74	13.0	11.9	11.0	10.2	8.84	7.80	6.94	6.24
80	MGPM	—	—	21.9	—	—	18.6	22.9	20.5	18.6	17.0	15.6	14.5	12.6	11.2	10.0	9.11
	MGPL	—	—	15.1	—	—	23.3	22.7	20.6	18.9	17.3	16.0	14.8	12.9	11.3	10.0	8.94
100	MGPM	—	—	38.8	—	—	33.5	37.5	33.8	30.9	28.4	26.2	24.4	21.4	19.1	17.2	15.7
	MGPL	—	—	27.1	—	—	30.6	37.9	34.6	31.8	29.3	27.2	25.3	22.1	19.5	17.3	15.5

Bore size (mm)	Non-rotating accuracy $\theta$	
	MGPM	MGPL
12		
16	$\pm 0.08^\circ$	$\pm 0.10^\circ$
20	$\pm 0.07^\circ$	$\pm 0.09^\circ$
25		
32	$\pm 0.06^\circ$	$\pm 0.08^\circ$
40		
50	$\pm 0.05^\circ$	$\pm 0.06^\circ$
63		
80	$\pm 0.04^\circ$	$\pm 0.05^\circ$
100		

# Series MGP Model Selection

## Selection Conditions

Mounting orientation	Vertical		Horizontal	
Maximum speed (mm/s)	200	400	200	400
Graph (Slide bearing type)	(1), (2)	(3), (4)	(13), (14)	(15), (16)
Graph (Ball bushing bearing type)	(5) to (8)	(9) to (12)	(17), (18)	(19), (20)

MX 

MTS

MY CY MG CX 

D-

-X

20-

Data

### Selection Example 1 (Vertical mounting)

#### Selection conditions

Mounting: Vertical  
 Bearing type: Ball bushing  
 Stroke: 30 stroke  
 Maximum speed: 200 mm/s  
 Load weight: 3 kg  
 Eccentric distance: 90 mm

Find the point of intersection for the load weight of 3 kg and the eccentric distance of 90 mm on graph (5), based on vertical mounting, ball bushing, 30 stroke, and the speed of 200 mm/s.

→ MGPL25-30 is selected.

#### (5) Less than 40 stroke, V = 200 mm/s

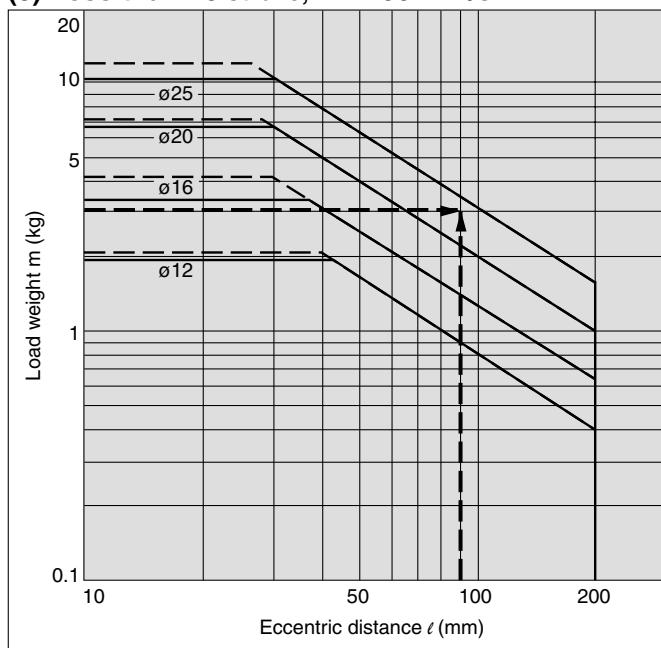

### Selection Example 2 (Horizontal mounting)

#### Selection conditions

Mounting: Horizontal  
 Bearing type: Slide bearing  
 Distance between plate and load center of gravity: 50 mm  
 Maximum speed: 200 mm/s  
 Load weight: 2 kg  
 Stroke: 30 stroke

Find the point of intersection for the load weight of 2 kg and 30 stroke on graph (13), based on horizontal mounting, slide bearing, the distance of 50 mm between the plate and load center of gravity, and the speed of 200 mm/s.

→ MGPM20-30 is selected.

#### (13) $l = 50$ mm, V = 200 mm/s

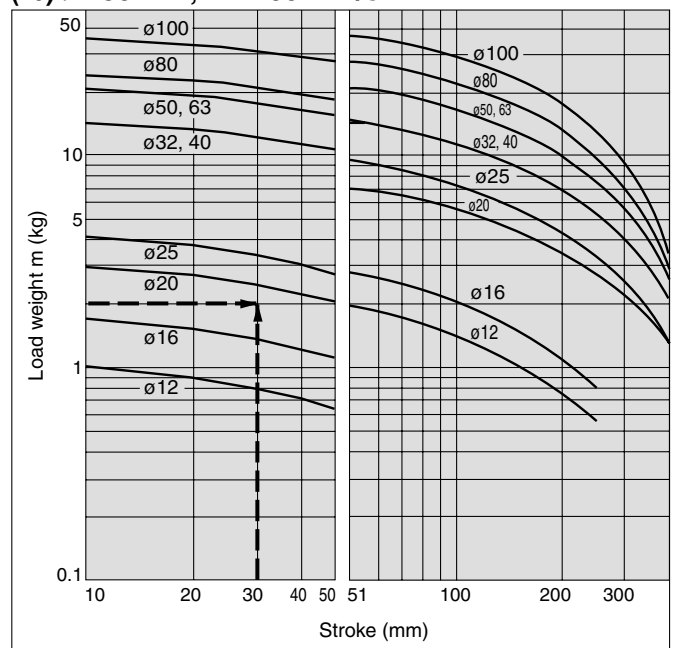

# Series MGP

## Vertical Mounting (Slide bearing)

— Operating pressure 0.4 MPa  
 - - - - - Operating pressure 0.5 MPa or more

### MGPM12 to 100

(1) 50 Stroke or Less, V = 200 mm/s

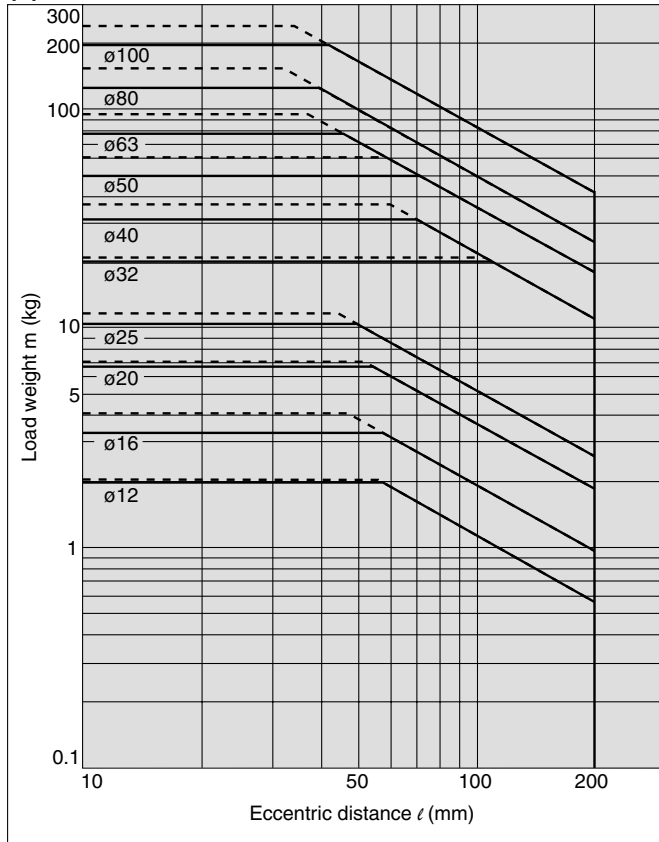

(2) Over 50 Stroke, V = 200 mm/s

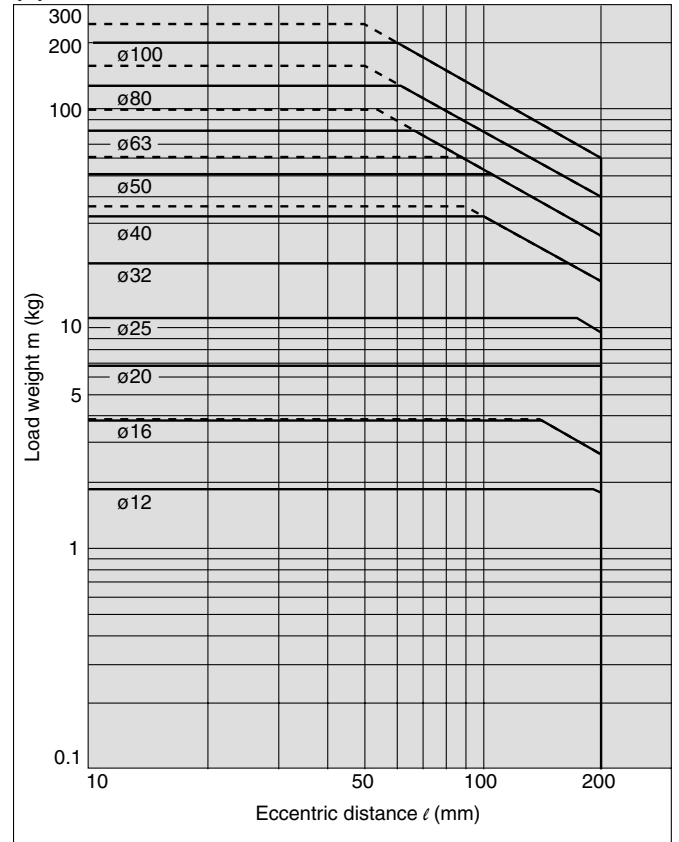

(3) 50 Stroke or Less, V = 400 mm/s

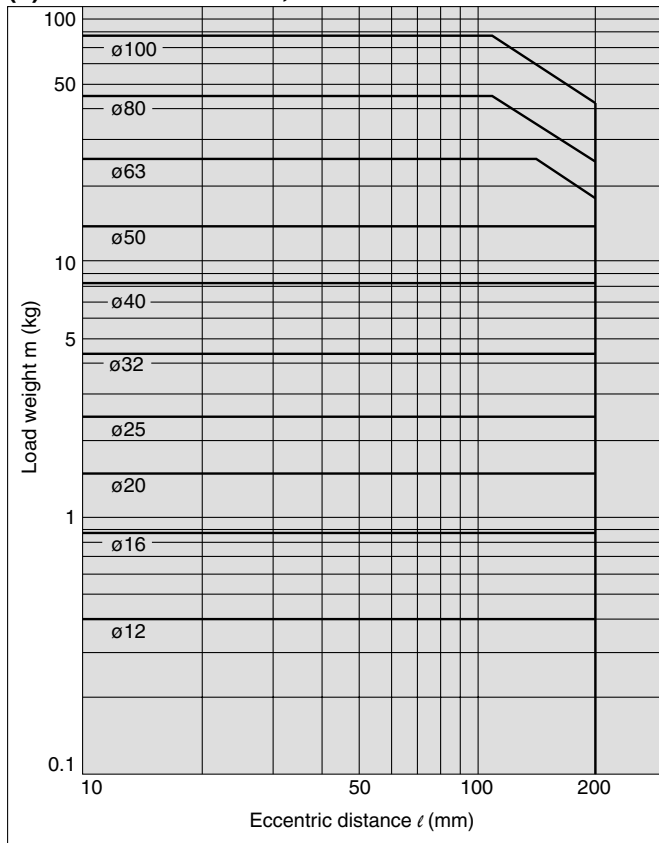

(4) Over 50 Stroke, V = 400 mm/s

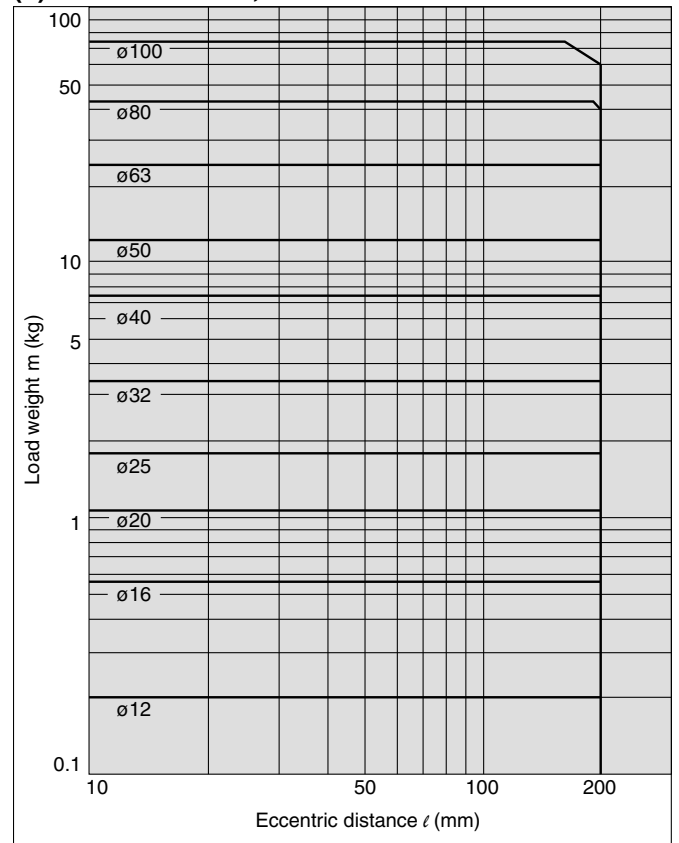

## Vertical Mounting (Ball bushing bearing)

— Operating pressure 0.4 MPa  
 - - - - - Operating pressure 0.5 MPa or more

### MGPL12 to 25

(5) 30 Stroke or Less, V = 200 mm/s

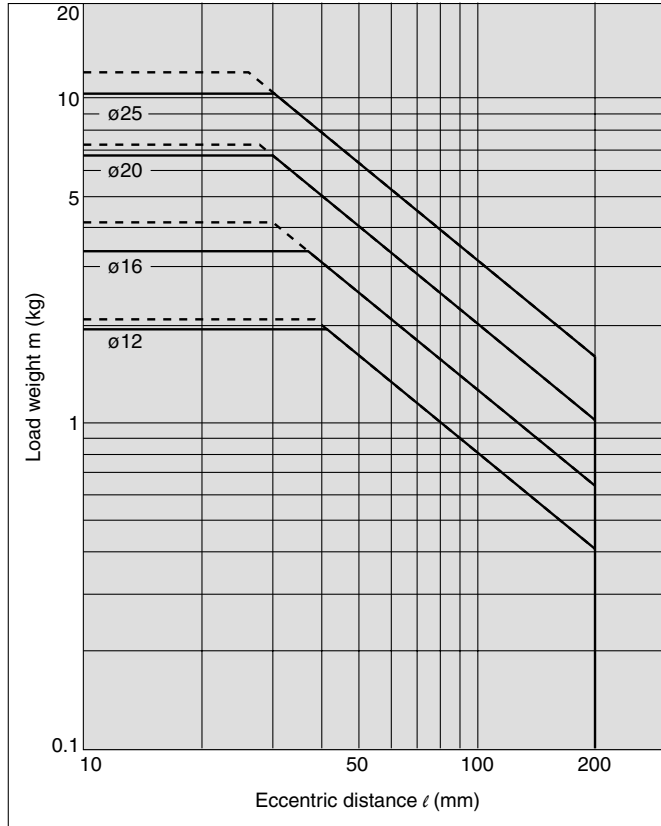

(6) Over 30 Stroke, V = 200 mm/s

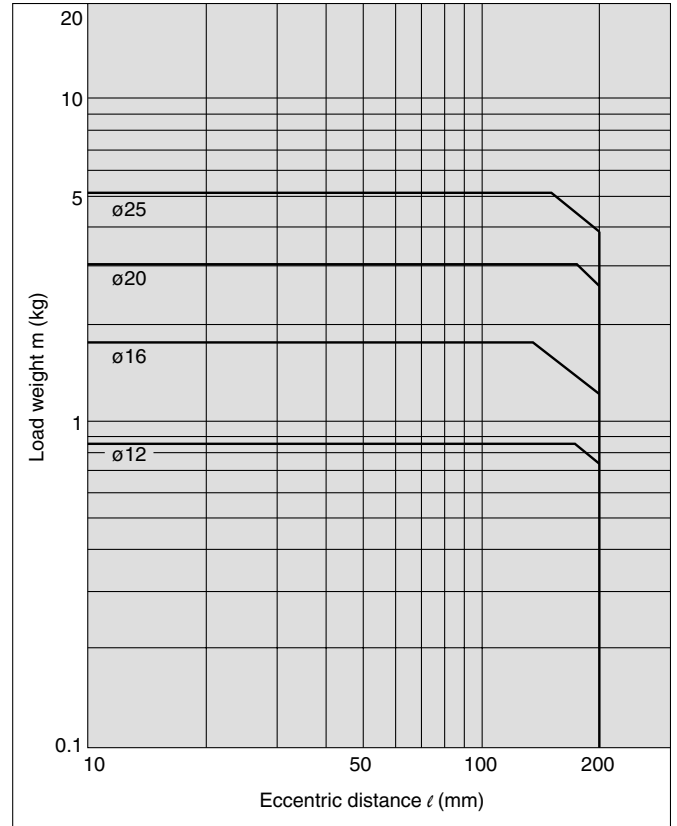

MX

MTS

MY

CY

MG

CX

D-

-X

20-

Data

### MGPL32 to 100

(7) 50 Stroke or Less, V = 200 mm/s

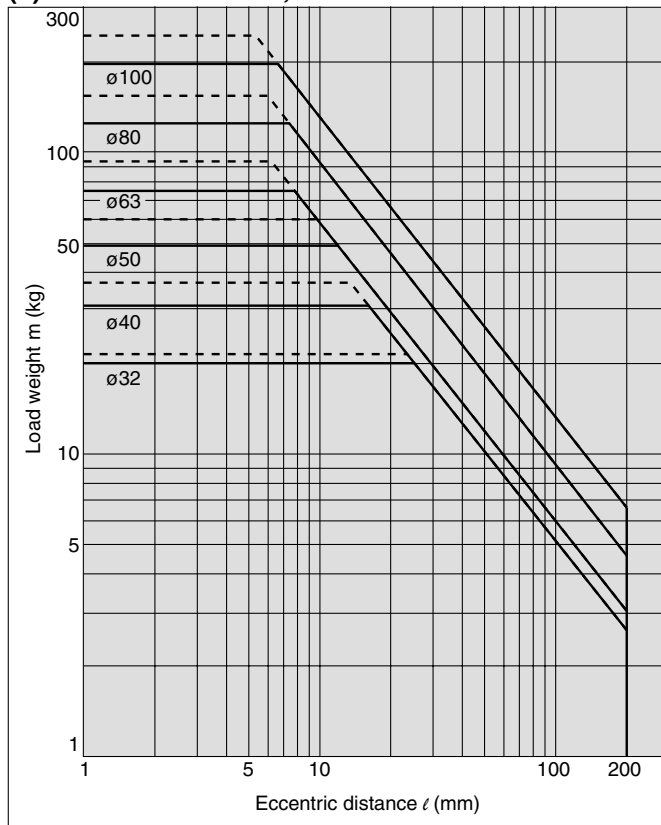

(8) Over 50 Stroke, V = 200 mm/s

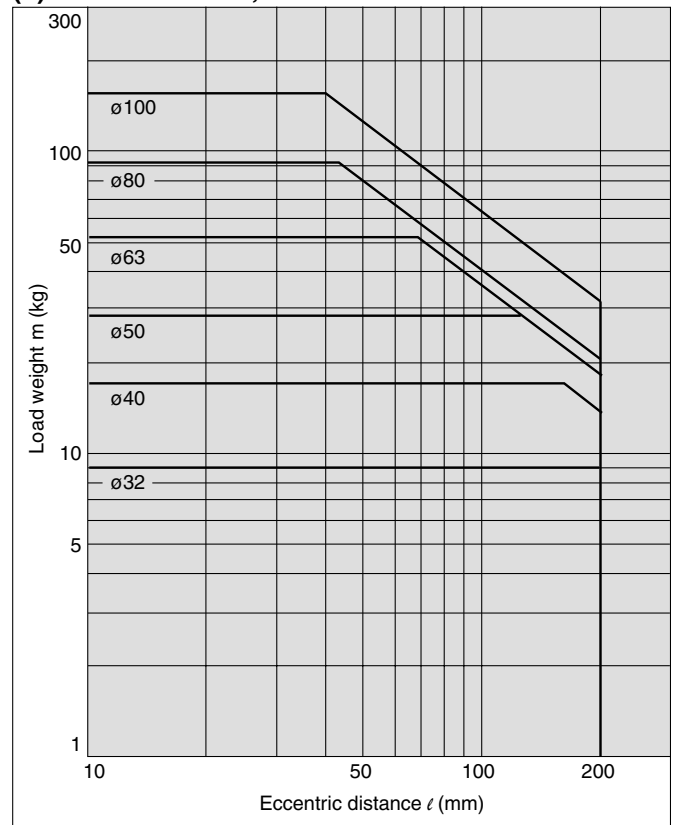

# Series MGP

## Vertical Mounting (Ball bushing bearing)

— Operating pressure 0.4 MPa

### MGPL12 to 25

(9) 30 Stroke or Less, V = 400 mm/s

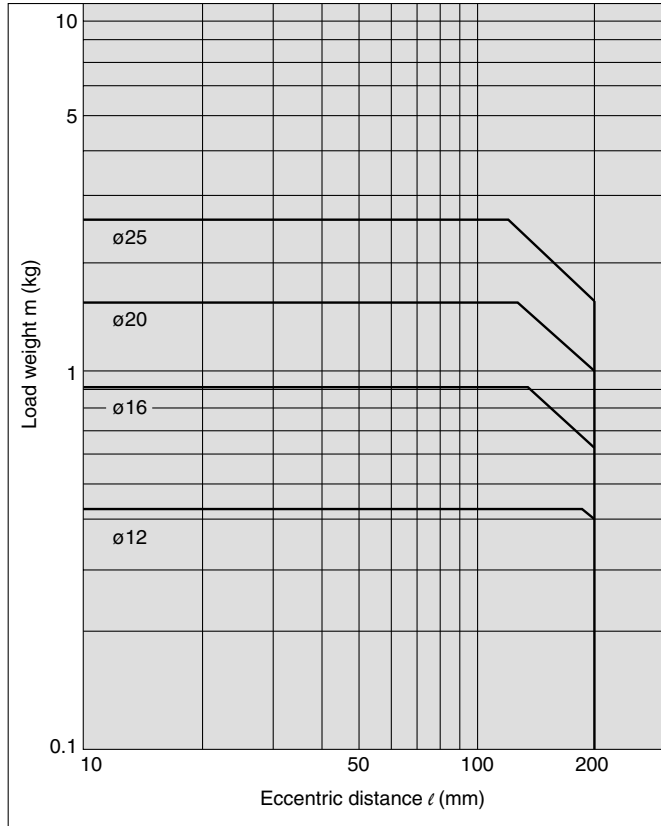

(10) Over 30 Stroke, V = 400 mm/s

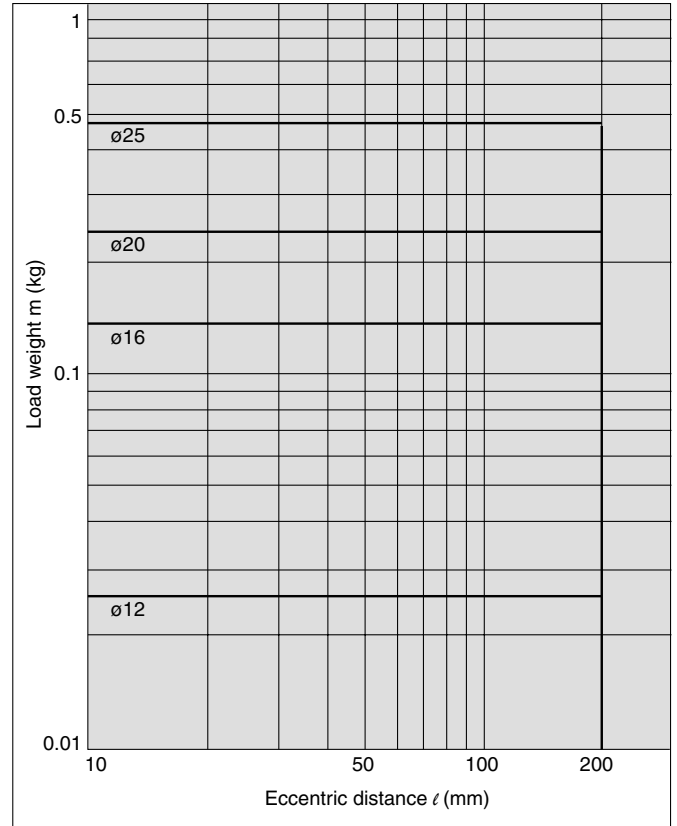

### MGPL32 to 100

(11) 50 Stroke or Less, V = 400 mm/s

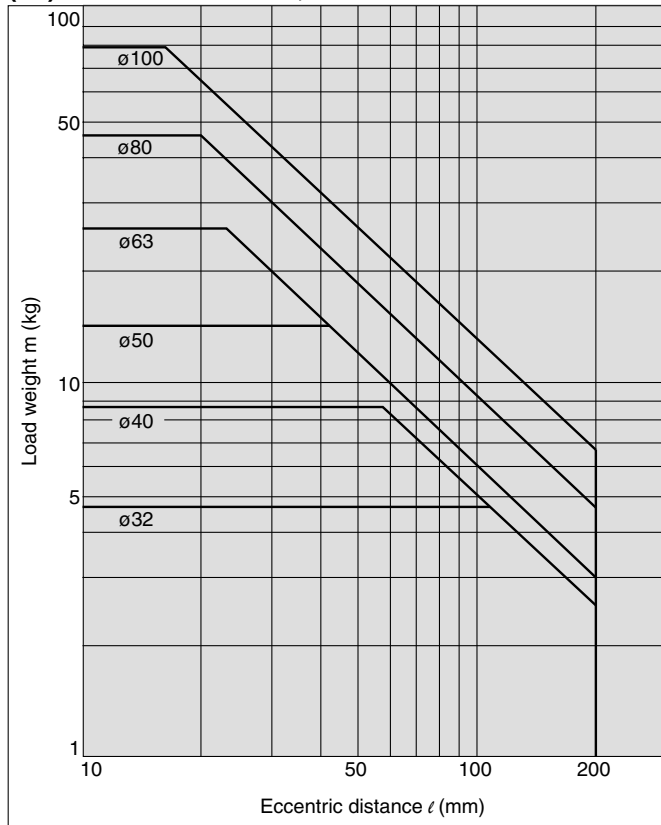

(12) Over 50 Stroke, V = 400 mm/s

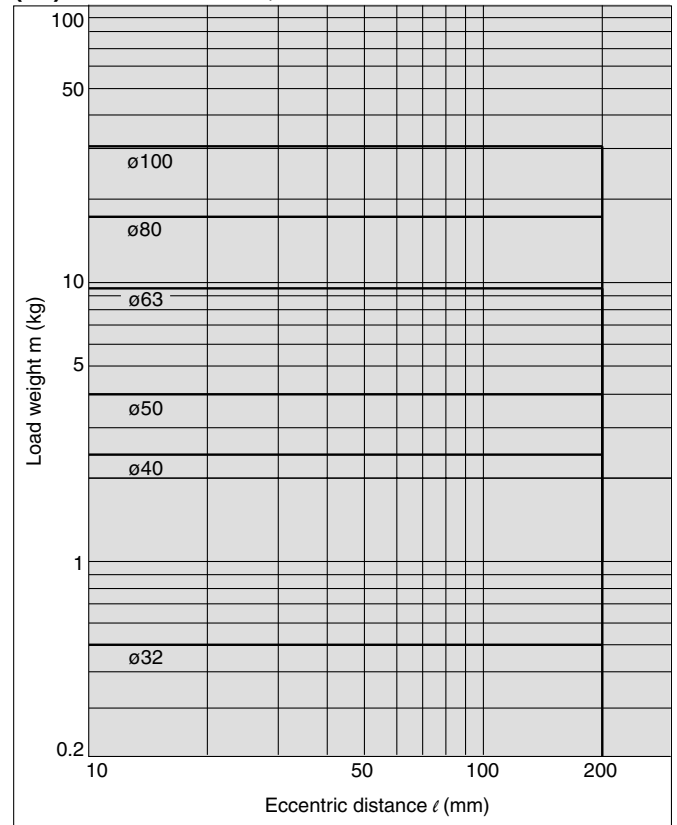

## Horizontal Mounting (Slide bearing)

MGPM12 to 100

(13)  $\ell = 50 \text{ mm}$ ,  $V = 200 \text{ mm/s}$

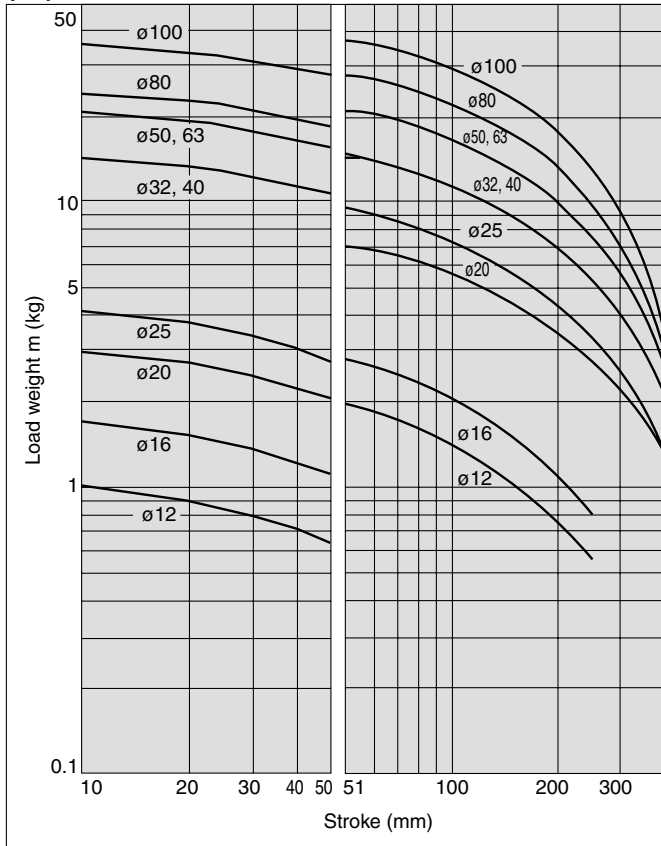

(14)  $\ell = 100 \text{ mm}$ ,  $V = 200 \text{ mm/s}$

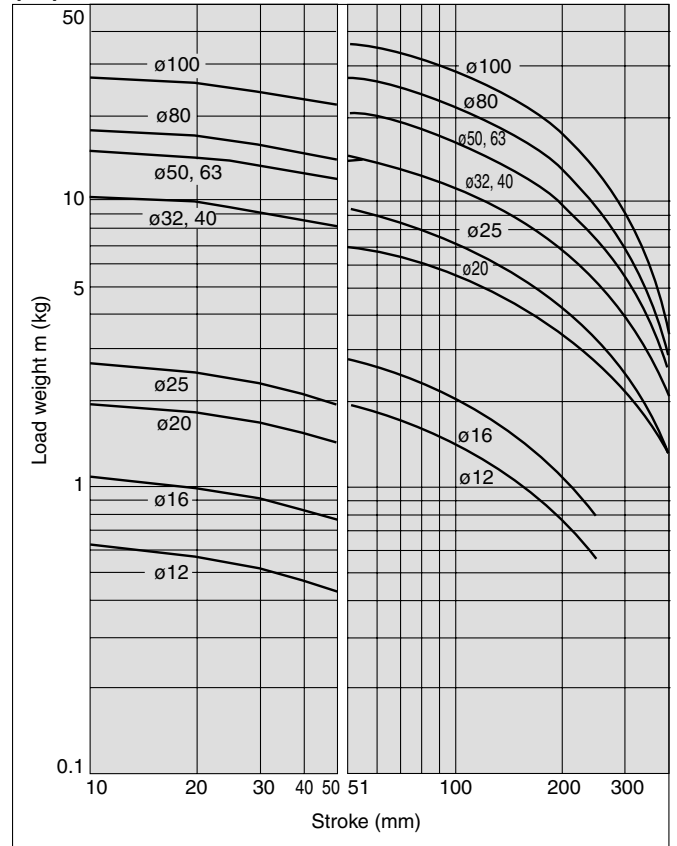

(15)  $\ell = 50 \text{ mm}$ ,  $V = 400 \text{ mm/s}$

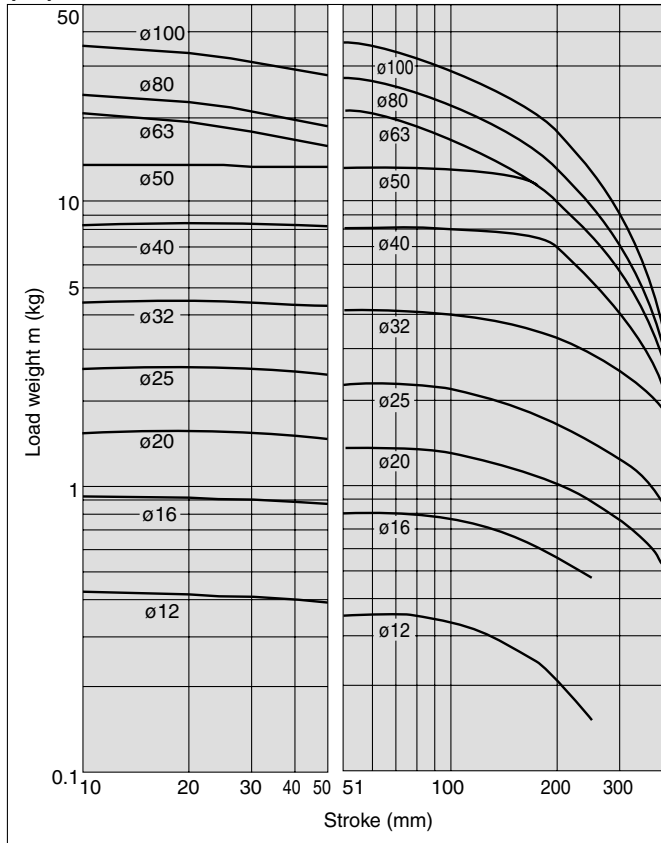

(16)  $\ell = 100 \text{ mm}$ ,  $V = 400 \text{ mm/s}$

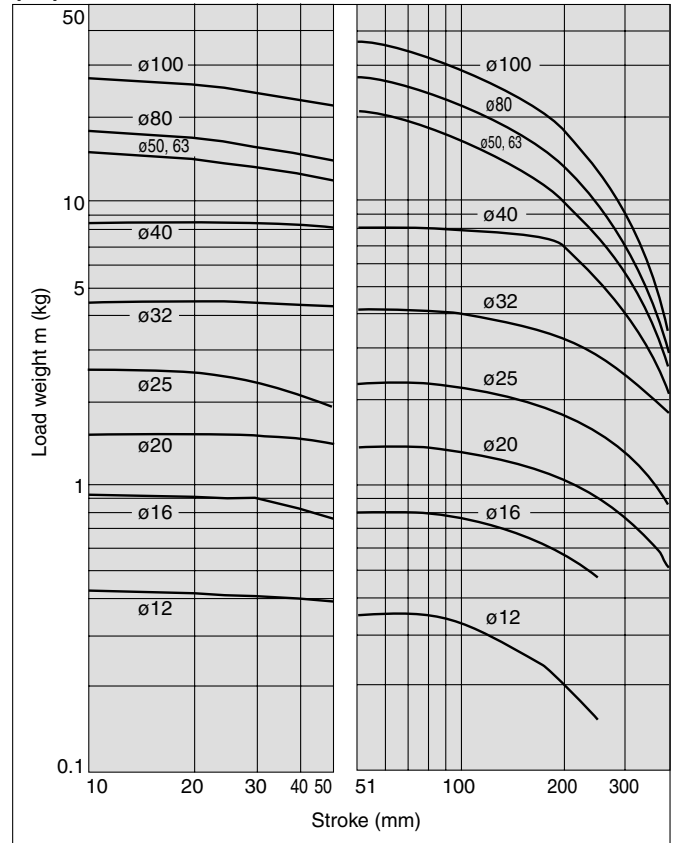

- MX
- MTS
- MY
- CY
- MG
- CX
- D-
- X
- 20-
- Data



# Series MGP

## Horizontal Mounting (Ball bushing bearing)

(17)  $l = 50 \text{ mm}$ ,  $V = 200 \text{ m/s}$

(18)  $l = 100 \text{ mm}$ ,  $V = 200 \text{ m/s}$

**MGPL12 to 25**

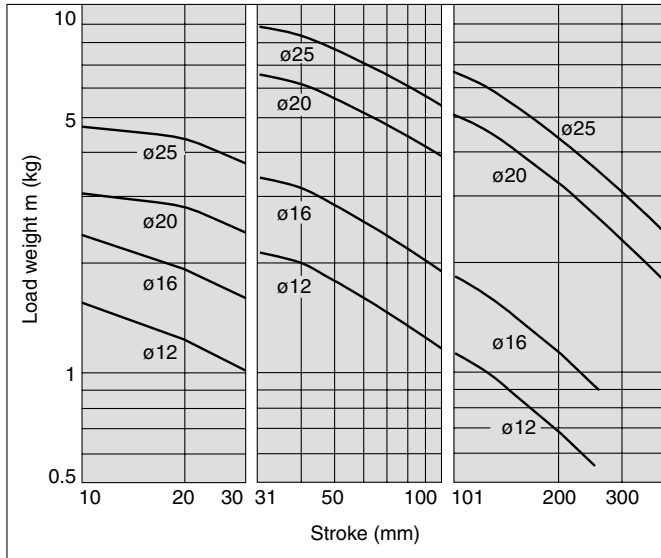

**MGPL12 to 25**

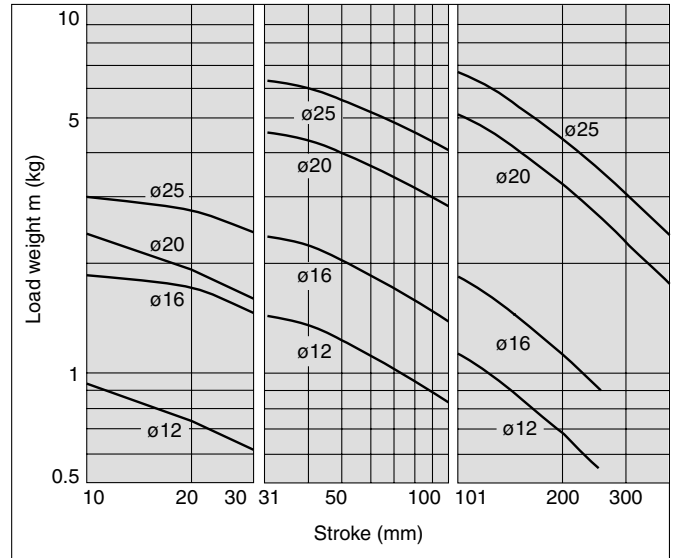

**MGPL32 to 63**

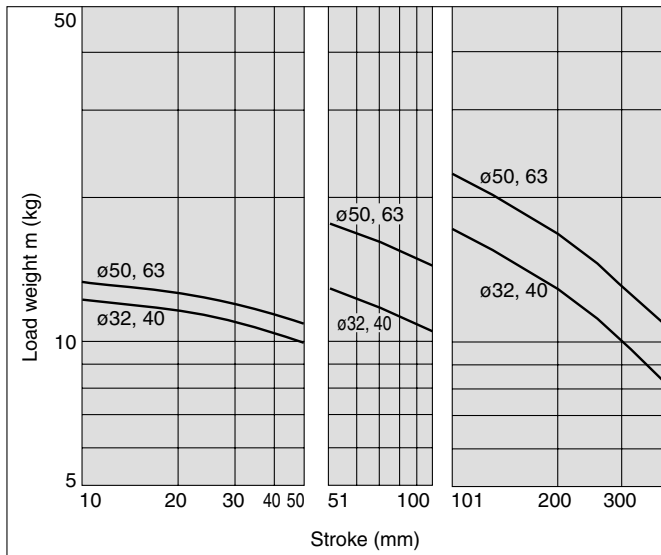

**MGPL32 to 63**

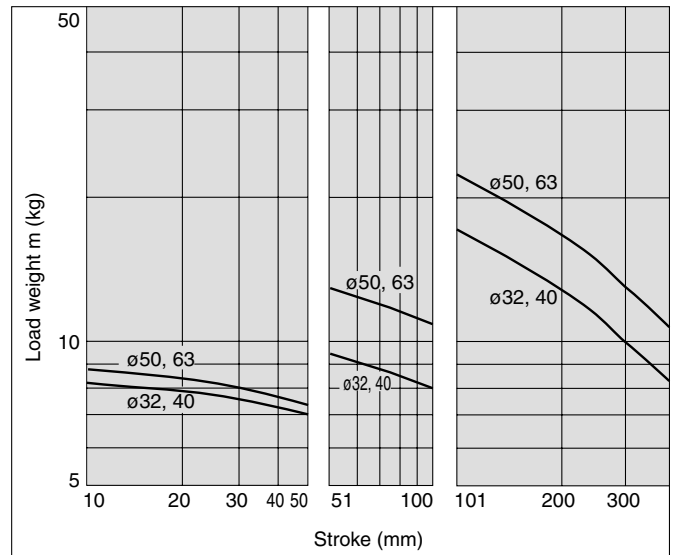

**MGPL80, 100**

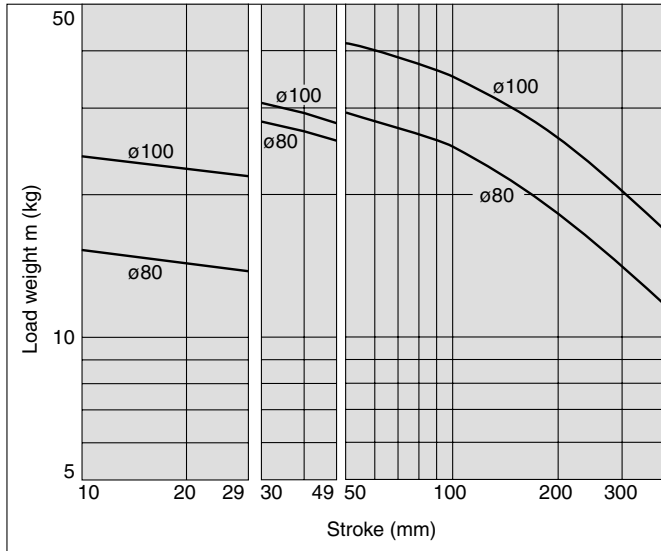

**MGPL80, 100**

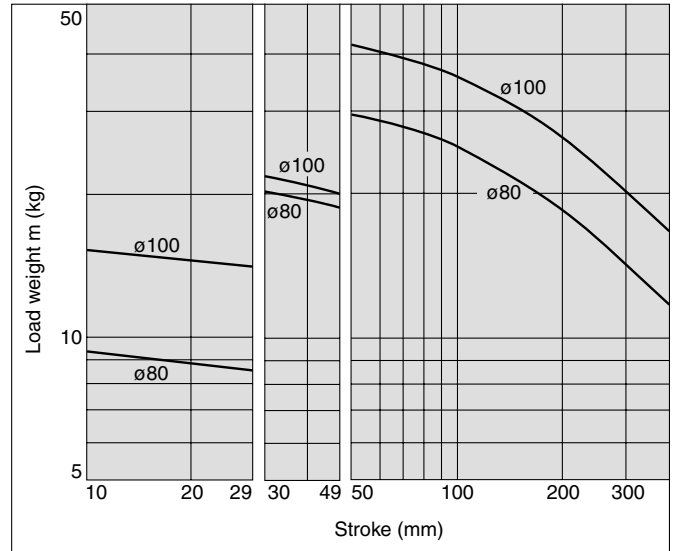

## Horizontal Mounting (Ball bushing bearing)

(19)  $\ell = 50 \text{ mm}$ ,  $V = 400 \text{ m/s}$

(20)  $\ell = 100 \text{ mm}$ ,  $V = 400 \text{ m/s}$

MGPL12 to 25

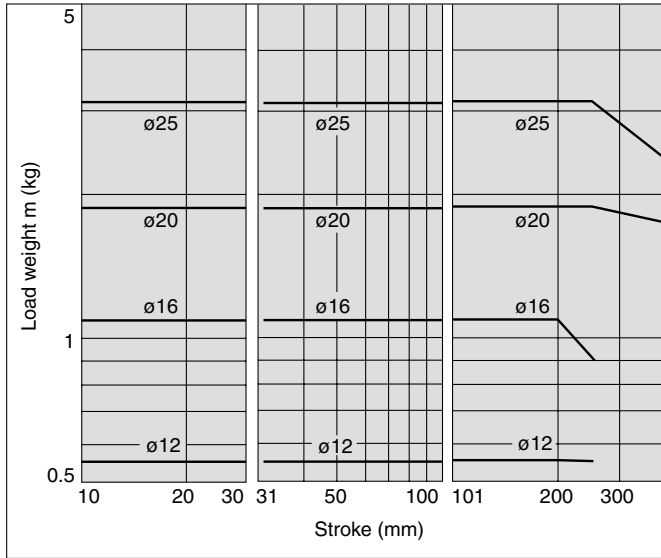

MGPL12 to 25

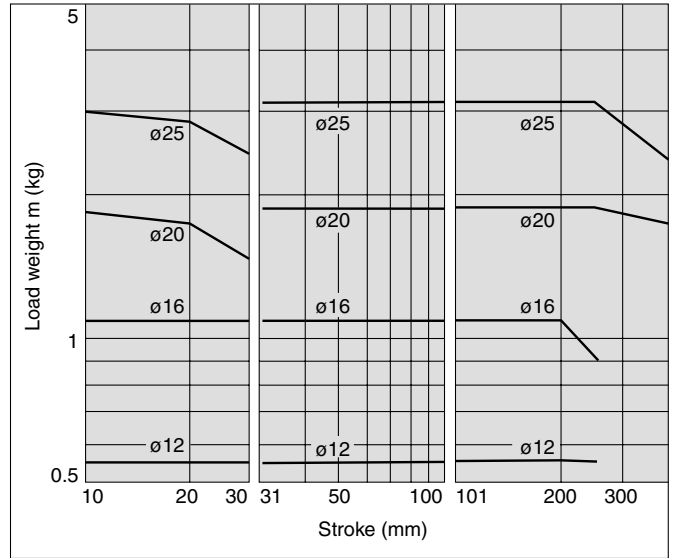

MGPL32 to 63

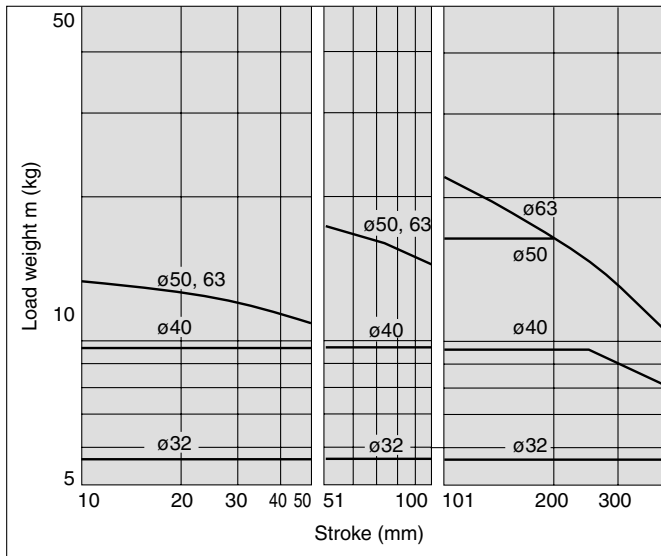

MGPL32 to 63

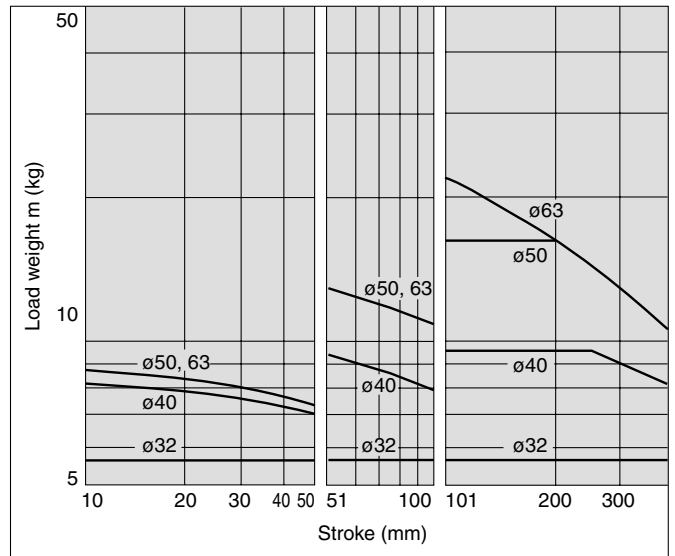

MGPL80, 100

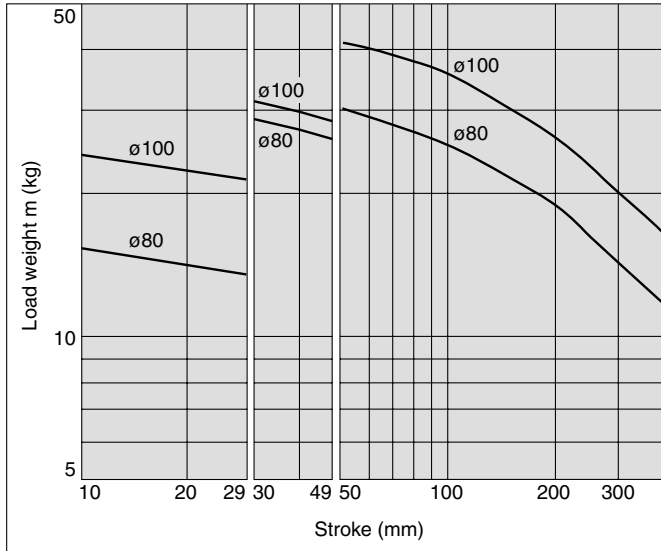

MGPL80, 100

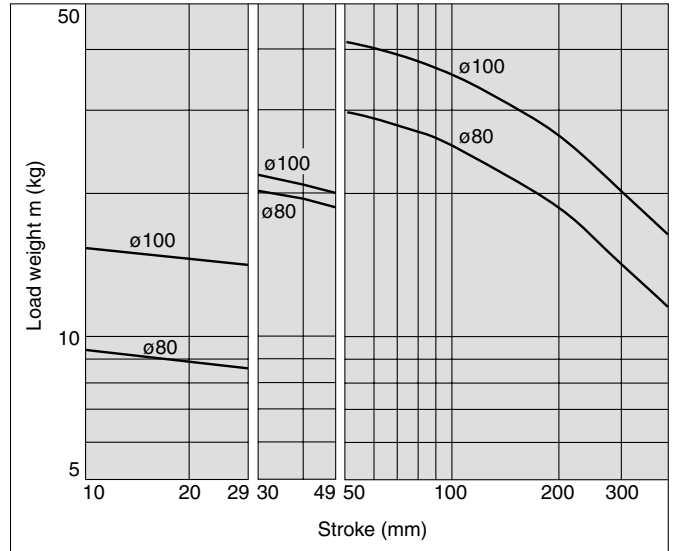

MX

MTS

MY

CY

MG

CX

D-

-X

20-

Data

# Series MGP

## Operating Range when Used as Stopper

### Bore Size: 12 to 25/MGPM12 to 25 (Slide bearing)

#### MGPM12 to 25 (Slide bearing)

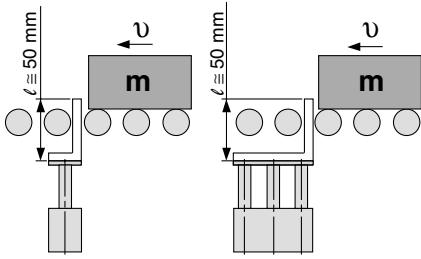

\* When selecting a model with a longer  $l$  dimension, be sure to choose a bore size which is sufficiently large.

#### ⚠ Caution Caution on handling

Note 1) When using as a stopper, select a model with 30 stroke or less.

Note 2) Model MGPL (Ball bushing bearing) cannot be used as a stopper.

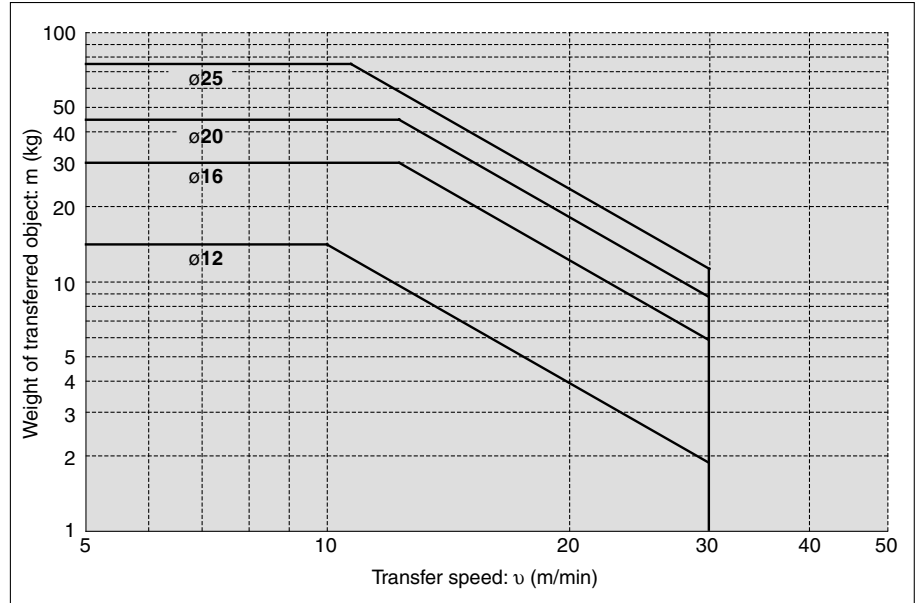

### Bore Size: 32 to 100/MGPM32 to 100 (Slide bearing)

#### MGPM32 to 100 (Slide bearing)

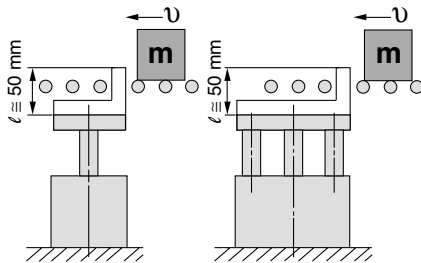

\* When selecting a model with a longer  $l$  dimension, be sure to choose a bore size which is sufficiently large.

#### ⚠ Caution Caution on handling

Note 1) When using as a stopper, select a model with 50 stroke or less.

Note 2) Model MGPL (Ball bushing bearing) cannot be used as a stopper.

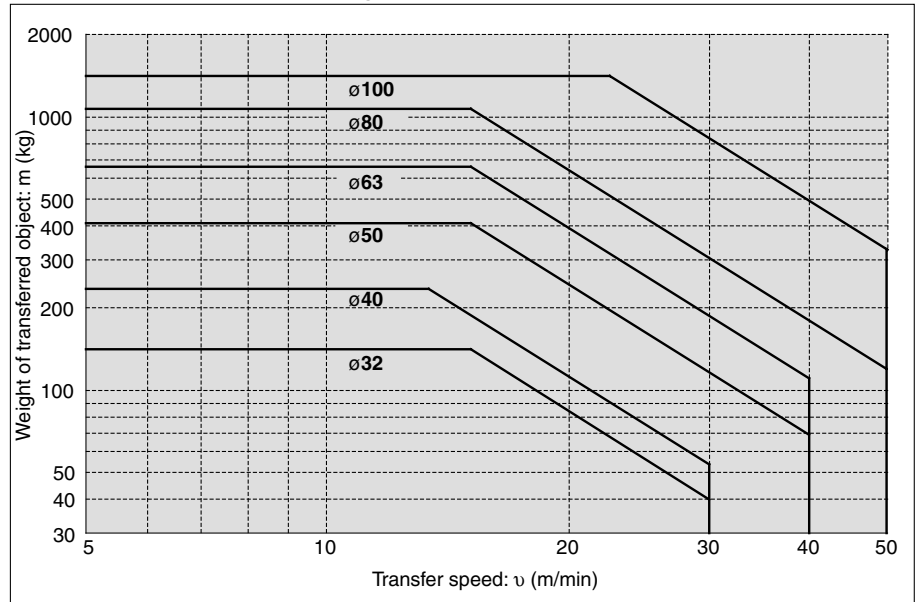

## 1. Water Resistant

Ideal for use in a machine tool environment exposed to coolants. Applicable for use in an environment with water splashing such as food processing and car wash equipment, etc.

### Specifications

Applicable series		<b>MGPM</b>
Bearing type		Slide bearing
Bore size (mm)		20, 25, 32, 40, 50, 63, 80, 100
Cushion	MGPM□□R	Rubber bumper
	MGPM□□V	Without cushion

\* Specifications other than above are the same as standard, basic style.

### How to Order

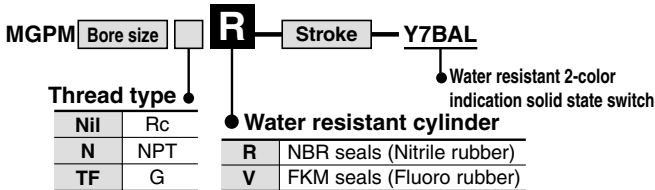

\* Stainless steel parts are available as made-to-order products.  
\* Piston rod and guide rod are made of stainless steel.

### Dimensions

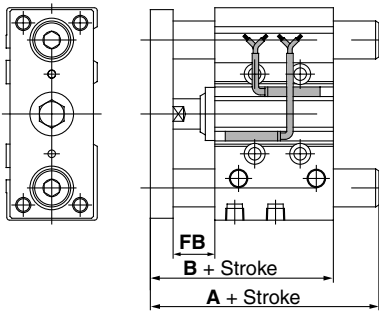

Bore size (mm)	A		B	FB
	50 stroke or less	51 stroke or more		
20	66	97.5	66	19
25	67.5	99	67.5	20
32	109	114	71.5	22
40	109	114	78	22
50	117.5	129	83	23
63	117.5	129	88	23
80	121	148	102.5	24
100	141	166	120	29

\* Other dimensions are the same as standard type.

## 2. Copper-free (For CRT manufacturing process)

To prevent the influence of copper ions or halogen ions during CRT manufacturing processes, copper and fluorine materials are not used in the component parts.

### Specifications

Applicable series	<b>MGPM</b>	<b>MGPL</b>
Bearing type	Slide bearing	Ball bushing bearing
Bore size (mm)	12, 16, 20, 25, 32, 40, 50, 63, 80, 100	

\* Specifications and dimensions other than above are the same as the standard, basic style.

### How to Order

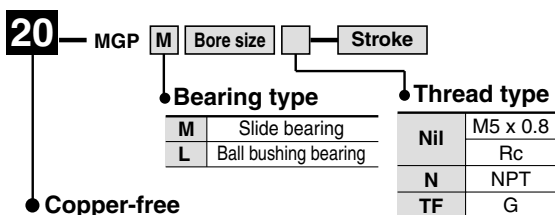

\* For bore sizes 12 and 16, M5 x 0.8 is only available.

## 3. Clean Series

Applicable in a clean room environment. Ideal for use in conveyor lines for semiconductor (LSI), liquid crystal (LCD), food processing, pharmaceutical, and electronic parts, etc.

### Specifications

Applicable series		<b>MGPL</b>							
Bearing type		Ball bushing bearing							
Bore size (mm)		12	16	20	25	32	40	50	63
Stroke (mm)		10 to 100		20 to 200		25 to 200			

\* Specifications other than above are the same as standard, basic style.

### How to Order

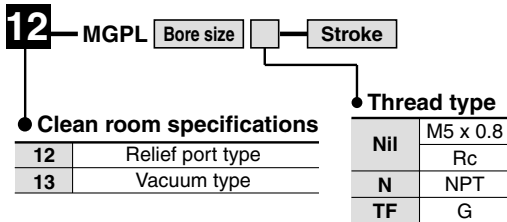

\* For bore sizes 12 and 16, M5 x 0.8 is only available.

### Dimensions

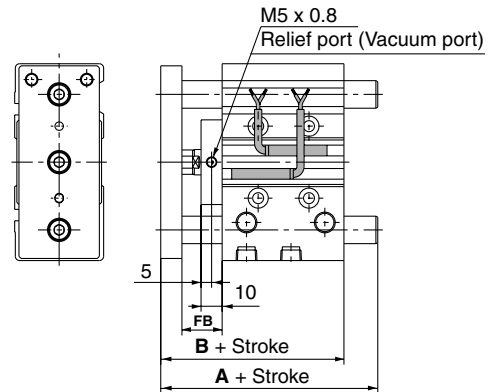

Bore size (mm)	A			B	FB
	30 st or less	Over 30 st to 100 st	Over 100 st		
12	56	68	—	55	18
16	62	78	—	59	18
20	76	93	117	66	19
25	82.5	98.5	117.5	66.5	19

Bore size (mm)	A			B	FB
	50 st or less	Over 50 st to 100 st	Over 100 st		
32	93	110	130	71.5	22
40	93	110	130	78	22
50	104	125	145	83	23
63	104	125	145	88	23

\* Other dimensions are the same as standard products.

MX□

MTS

MY□

CY□

MG□

CX□

D-

-X

20-

Data

# Series MGP

## Proper Auto Switch Mounting Position (Detection at stroke end) and Its Mounting Height

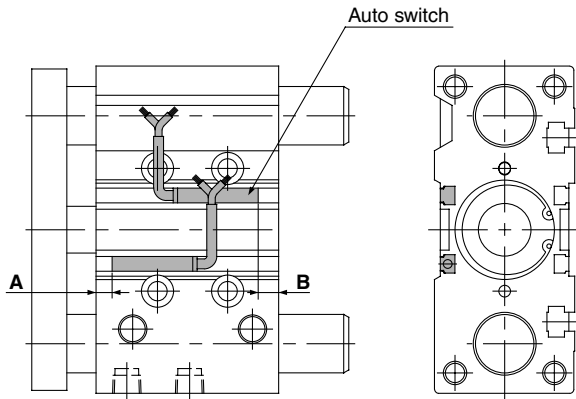

### Proper Mounting Position

Bore size (mm)	A	B
12	1.5	3
16	4.5	4
20	4	8
25	4.5	8
32	5.5	7

Bore size (mm)	A	B
40	9.5	9.5
50	7.5	11.5
63	10	14
80	13	18.5
100	17.5	23.5

Note 1) Minimum mountable strokes for auto switch are 10 stroke or more for two switches, and 5 stroke or more for one switch.

Note 2) D-P5DW type can be mounted only on bore sizes 40 through 100.

### For D-P5DW (\* Cannot be mounted on bore sizes $\phi 32$ or less.) $\phi 40$ to $\phi 63$

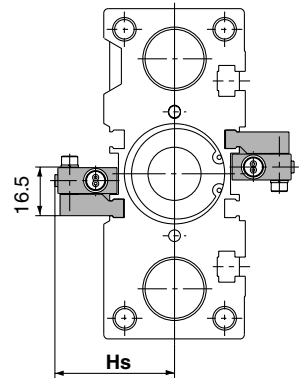
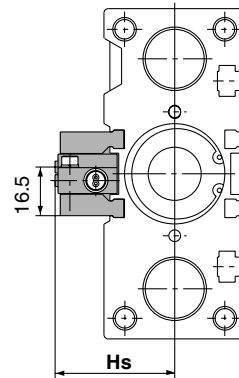

### $\phi 80, \phi 100$

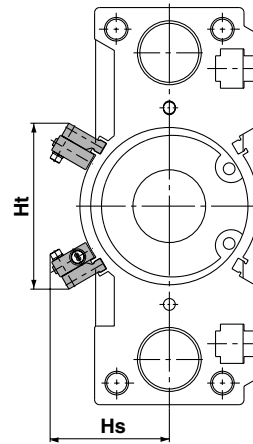

### For 25 stroke

\* For bore sizes 40 through 63 with two switches, one switch is mounted on each side.

Bore size (mm)	Hs	Ht
40	44.5	—
50	50	—
63	57	—
80	60.7	84.4
100	70.8	96.1

\* Minimum mountable strokes for auto switch are 10 stroke or more for two switches, and 5 stroke or more for one switch.

## Operating Range

Auto switch model	Applicable bore size (mm)									
	12	16	20	25	32	40	50	63	80	100
D-Z7□/Z80	7.5	10	10	10	10.5	10.5	10.5	11.5	11.5	12
D-Y59□/Y69□/Y7P/Y7PV D-Y7□W/Y7□WV	5.5	7.5	7.5	7	6.5	6	7	8	9.5	10
D-Y7BAL	3.5	5	5	5	6	6	6	6	6	6.5
D-P5DWL	—	—	—	—	—	4	4	5	4	4

Other than the applicable auto switches listed in "How to Order", the following auto switches can be mounted. For detailed specifications, refer to page 8-30-1.

Type	Model	Electrical entry (Fetching direction)	Features
Reed switch	D-Z80	Grommet (In-line)	Without indicator light

\* Normally closed (NC = b contact), solid state switch (D-Y7G/Y7H type) are also available. For details, refer to page 8-30-32.

## Construction

### Series MGPM

### Series MGPL

#### MGPM12 to 25

#### MGPL12 to 25

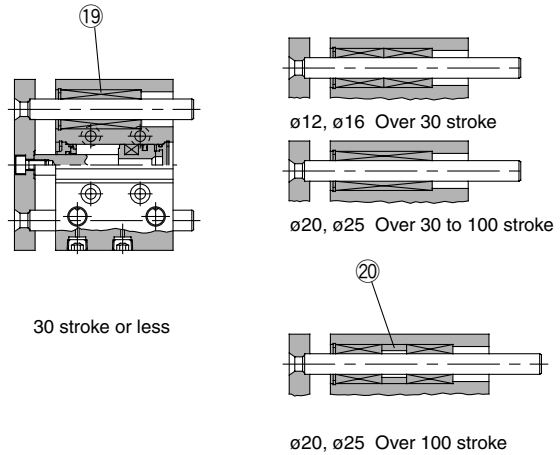
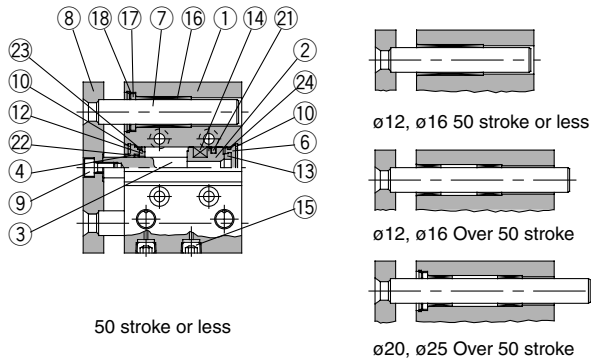

#### MGPM32 to 100

#### MGPL32 to 100

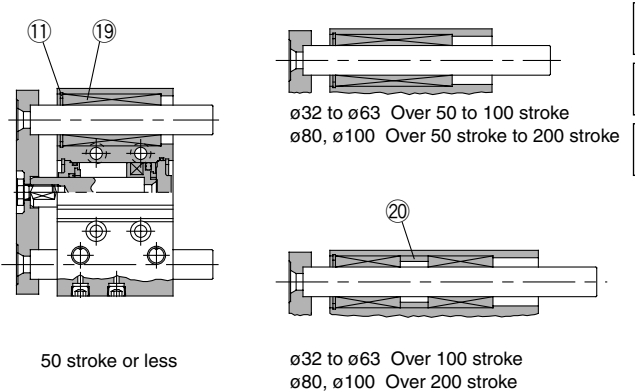
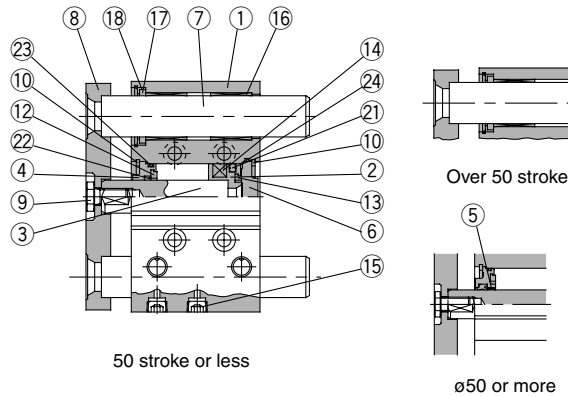

## Component Parts

No.	Description	Material	Note
①	Body	Aluminum alloy	Hard anodized
②	Piston	Aluminum alloy	Chromated
③	Piston rod	Stainless steel	ø12 to ø25
		Carbon steel	ø32 to ø100 Hard chrome plated
④	Collar	Aluminum alloy	ø12 to ø40 Clear anodized
		Aluminum alloy casted	ø50 to ø100 Painted
⑤	Bushing	Lead bronze casting	ø50 to ø100
⑥	Head cover	Aluminum alloy	ø12 to ø63 Colorless chromated
			ø80 to ø100 Painted
⑦	Guide rod	Carbon steel	Hard chrome plated
⑧	Plate	Carbon steel	Nickel plated
⑨	Plate mounting bolt	Carbon steel	Nickel plated
⑩	Snap ring	Carbon tool steel	Phosphate coated
⑪	Snap ring	Carbon tool steel	Phosphate coated

No.	Description	Material	Note
⑫	Bumper A	Urethane	
⑬	Bumper B	Urethane	
⑭	Magnet	Magnetic material	
⑮	Plug (M-5P) Hexagon socket head taper plug	Brass	ø12, ø16 Nickel plated
		Carbon steel	ø20 to ø100 Nickel plated
⑯	Slide Bearing	Lead-bronze casted	
⑰	Felt	Felt	Except ø12, ø16
⑱	Holder	Resin	Except ø12, ø16
⑲	Ball bushing		
⑳	Spacer	Aluminum alloy	
㉑*	Piston seal	NBR	
㉒*	Rod seal	NBR	
㉓*	Gasket A	NBR	
㉔*	Gasket B	NBR	

## Replacement Parts: Seal Kit

Bore size (mm)	Kit no.	Contents
12	MGP12-PS	Set of nos. above ㉑, ㉒, ㉓, ㉔
16	MGP16-PS	
20	MGP20-PS	
25	MGP25-PS	
32	MGP32-PS	

Bore size (mm)	Kit no.	Contents
40	MGP40-PS	Set of nos. above ㉑, ㉒, ㉓, ㉔
50	MGP50-PS	
63	MGP63-PS	
80	MGP80-PS	
100	MGP100-PS	

\* Seal kit includes ㉑ to ㉔. Order the seal kit, based on each bore size.

MX

MTS

MY

CY

MG

CX

D-

-X

20-

Data

# Series MGP

## MGPM, MGPL: $\phi 12$ to $\phi 25$

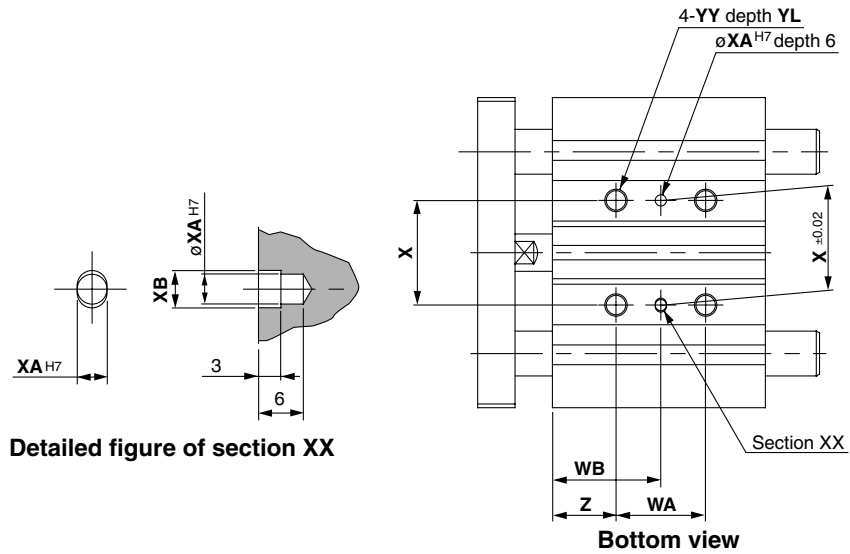

### T-slot dimensions

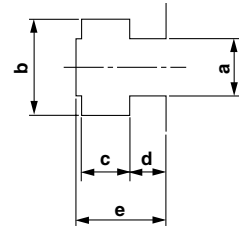

Bore size (mm)	a	b	c	d	e
12	4.4	7.4	3.7	2	6.2
16	4.4	7.4	3.7	2.5	6.7
20	5.4	8.4	4.5	2.8	7.8
25	5.4	8.4	4.5	3	8.2

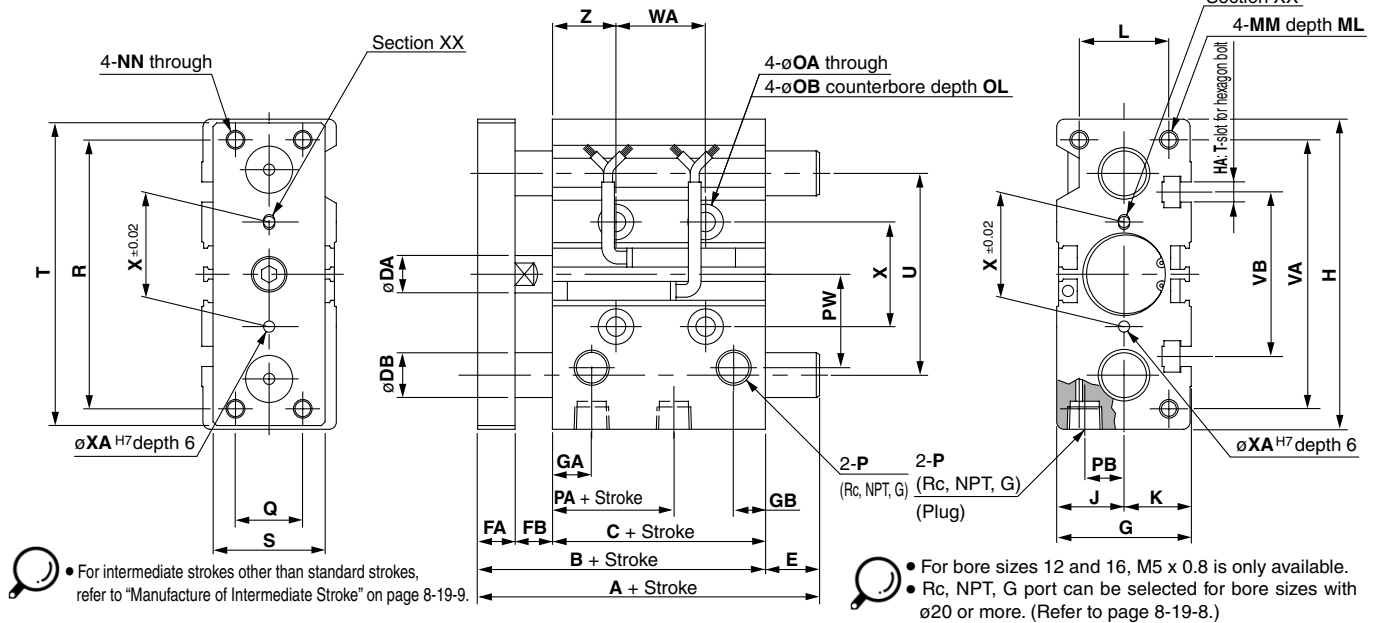

### MGPM, MGPL Common Dimensions

Bore size (mm)	Standard stroke (mm)	B	C	DA	FA	FB	G	GA	GB	H	HA	J	K	L	MM	ML	NN	OA	OB	OL	P	PA	PB	PW
12	10, 20, 30, 40, 50, 75, 100	42	29	6	8	5	26	11	7.5	58	M4	13	13	18	M4 x 0.7	10	M4 x 0.7	4.3	8	4.5	M5 x 0.8	13	8	18
16	125, 150, 175, 200, 250	46	33	8	8	5	30	11	8	64	M4	15	15	22	M5 x 0.8	12	M5 x 0.8	4.3	8	4.5	M5 x 0.8	15	10	19
20	20, 30, 40, 50, 75, 100 125, 150, 175, 200	53	37	10	10	6	36	10.5	8.5	83	M5	18	18	24	M5 x 0.8	13	M5 x 0.8	5.6	9.5	5.5	1/8	12.5	10.5	25
25	250, 300, 350, 400	53.5	37.5	12	10	6	42	11.5	9	93	M5	21	21	30	M6 x 1.0	15	M6 x 1.0	5.6	9.5	5.5	1/8	12.5	13.5	28.5

Bore size (mm)	Q	R	S	T	U	VA	VB	WA				WB				X	XA	XB	YY	YL	Z		
								30 st or less	Over 30 st to 100 st	Over 100 st to 200 st	Over 200 st to 300 st	Over 300 st	30 st or less	Over 30 st to 100 st	Over 100 st to 200 st							Over 200 st to 300 st	Over 300 st
12	14	48	22	56	41	50	37	20	40	110	200	—	15	25	60	105	—	23	3	3.5	M5 x 0.8	10	5
16	16	54	25	62	46	56	38	24	44	110	200	—	17	27	60	105	—	24	3	3.5	M5 x 0.8	10	5
20	18	70	30	81	54	72	44	24	44	120	200	300	29	39	77	117	167	28	3	3.5	M6 x 1.0	12	17
25	26	78	38	91	64	82	50	24	44	120	200	300	29	39	77	117	167	34	4	4.5	M6 x 1.0	12	17

### MGPM (Slide bearing) A, DB, E Dimensions

Bore size (mm)	A			DB	E		
	50 st or less	Over 50 st to 100 st	Over 100 st		50 st or less	Over 50 st to 100 st	Over 100 st
12	42	60.5	85	8	0	18.5	43
16	46	64.5	95	10	0	18.5	49

### MGPL (Ball bushing bearing) A, DB, E Dimensions

Bore size (mm)	A			DB	E		
	30 st or less	Over 30 st to 100 st	Over 100 st		30 st or less	Over 30 st to 100 st	Over 100 st
12	43	55	85	6	1	13	43
16	49	65	95	8	3	19	49

### MGPM (Slide bearing) A, DB, E Dimensions

Bore size (mm)	A			DB	E		
	50 st or less	Over 50 st to 200 st	Over 200 st		50 st or less	Over 50 st to 200 st	Over 200 st
20	53	84.5	122	12	0	31.5	69
25	53.5	85	122	16	0	31.5	68.5

### MGPL (Ball bushing bearing) A, DB, E Dimensions

Bore size (mm)	A				DB	E			
	30 st or less	Over 30 st to 100 st	Over 100 st to 200 st	Over 200 st		30 st or less	Over 30 st to 100 st	Over 100 st to 200 st	Over 200 st
20	63	80	104	122	10	10	27	51	69
25	69.5	85.5	104.5	122	13	16	32	51	68.5

## MGPM, MGPL: $\phi 32$ to $\phi 63$

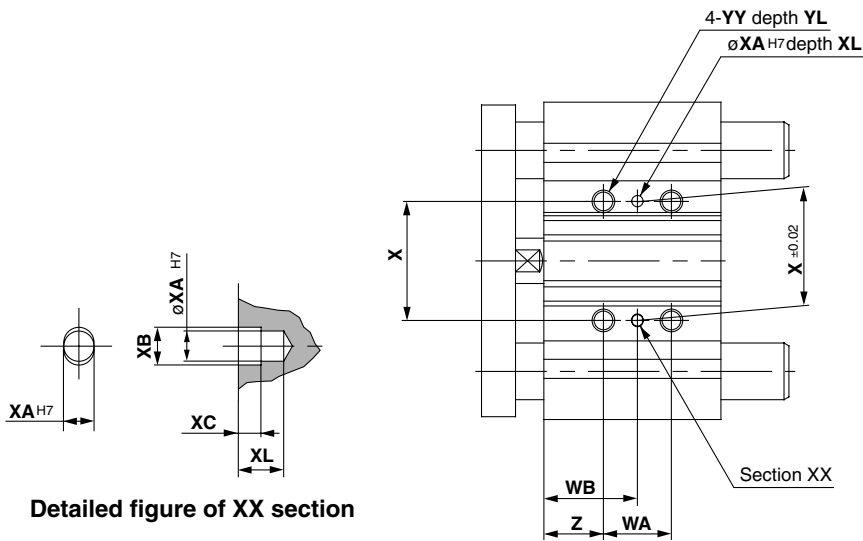

### T-slot dimensions

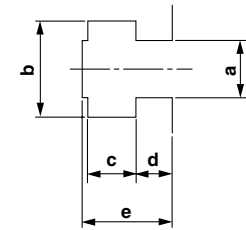

Bore size (mm)	a	b	c	d	e
32	6.5	10.5	5.5	3.5	9.5
40	6.5	10.5	5.5	4	11
50	8.5	13.5	7.5	4.5	13.5
63	11	17.8	10	7	18.5

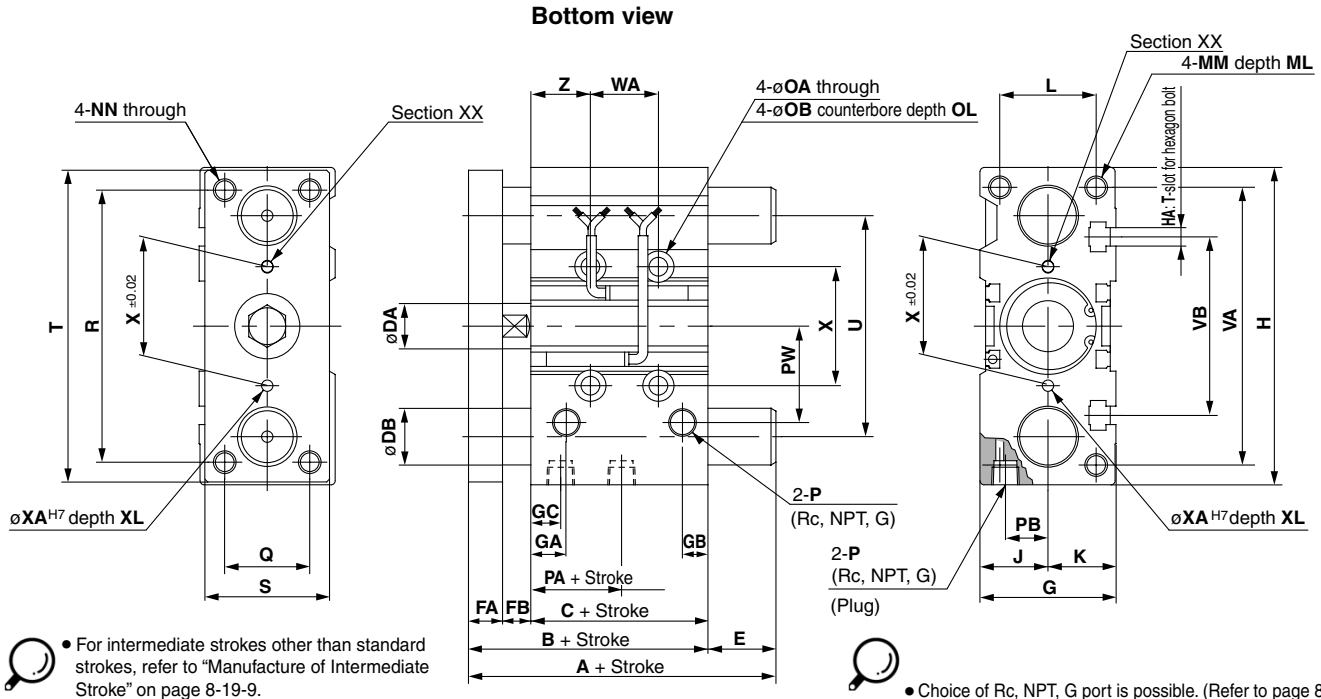

### MGPM, MGPL Common Dimensions

Bore size (mm)	Standard stroke (mm)	B	C	DA	FA	FB	G	GA	GB	GC	H	HA	J	K	L	MM	ML	NN	OA	OB	OL	P	PA	PB	PW	Q
		32	25, 50, 75, 100,	59.5	37.5	16	12	10	48	12.5	9	12.5	112	M6	24	24	34	M8 x 1.25	20	M8 x 1.25	6.6	11	7.5	1/8	7	15
40	125, 150, 175, 200	66	44	16	12	10	54	14	10	14	120	M6	27	27	40	M8 x 1.25	20	M8 x 1.25	6.6	11	7.5	1/8	13	18	38	30
50	250, 300, 350, 400	72	44	20	16	12	64	14	11	12	148	M8	32	32	46	M10 x 1.5	22	M10 x 1.5	8.6	14	9	1/4	9	21.5	47	40
63		77	49	20	16	12	78	16.5	13.5	16.5	162	M10	39	39	58	M10 x 1.5	22	M10 x 1.5	8.6	14	9	1/4	14	28	55	50

Bore size (mm)	R	S	T	U	VA	VB	WA					WB					X	XA	XB	XC	XL	YY	YL	Z
							25 st or less	Over 25 st to 100 st	Over 100 st to 200 st	Over 200 st to 300 st	Over 300 st	25 st or less	Over 25 st to 100 st	Over 100 st to 200 st	Over 200 st to 300 st	Over 300 st								
32	96	44	110	78	98	63	24	48	124	200	300	33	45	83	121	171	42	4	4.5	3	6	M8 x 1.25	16	21
40	104	44	118	86	106	72	24	48	124	200	300	34	46	84	122	172	50	4	4.5	3	6	M8 x 1.25	16	22
50	130	60	146	110	130	92	24	48	124	200	300	36	48	86	124	174	66	5	6	4	8	M10 x 1.5	20	24
63	130	70	158	124	142	110	28	52	128	200	300	38	50	88	124	174	80	5	6	4	8	M10 x 1.5	20	24

### MGPM (Slide bearing) A, DB, E Dimensions

Bore size (mm)	A			DB	E		
	50 st or less	Over 50 st to 200 st	Over 200 st		50 st or less	Over 50 st to 200 st	Over 200 st
32	97	102	140	20	37.5	42.5	80.5
40	97	102	140	20	31	36	74
50	106.5	118	161	25	34.5	46	89
63	106.5	118	161	25	29.5	41	84

### MGPL (Ball bushing bearing) A, DB, E Dimensions

Bore size (mm)	A				DB	E			
	50 st or less	Over 50 st to 100 st	Over 100 st to 200 st	Over 200 st		50 st or less	Over 50 st to 100 st	Over 100 st to 200 st	Over 200 st
32	81	98	118	140	16	21.5	38.5	58.5	80.5
40	81	98	118	140	16	15	32	52	74
50	93	114	134	161	20	21	42	62	89
63	93	114	134	161	20	16	37	57	84



# Series MGP

MGPM, MGPL:  $\phi 80$ ,  $\phi 100$

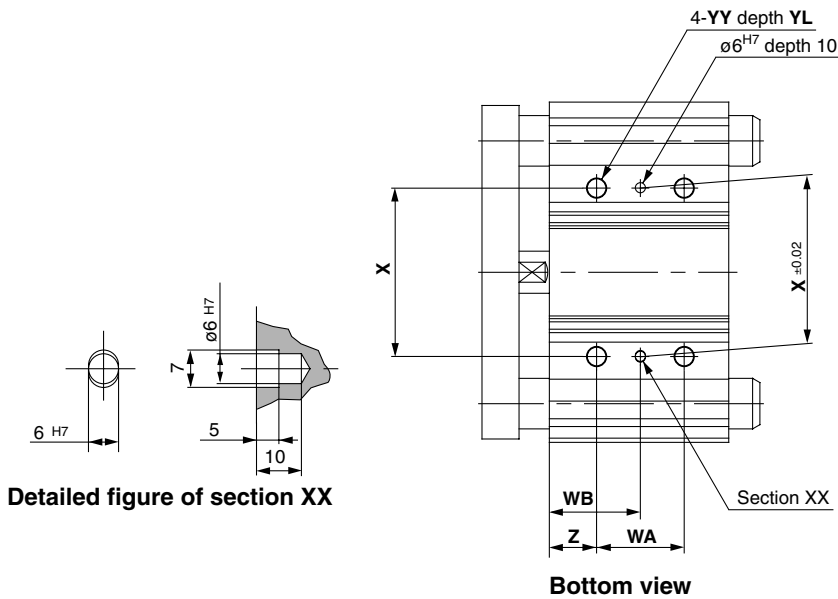

## T-slot dimensions

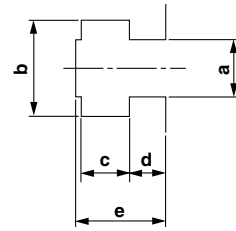

Bore size (mm)	a	b	c	d	e
80	13.3	20.3	12	8	22.5
100	15.3	23.3	13.5	10	30

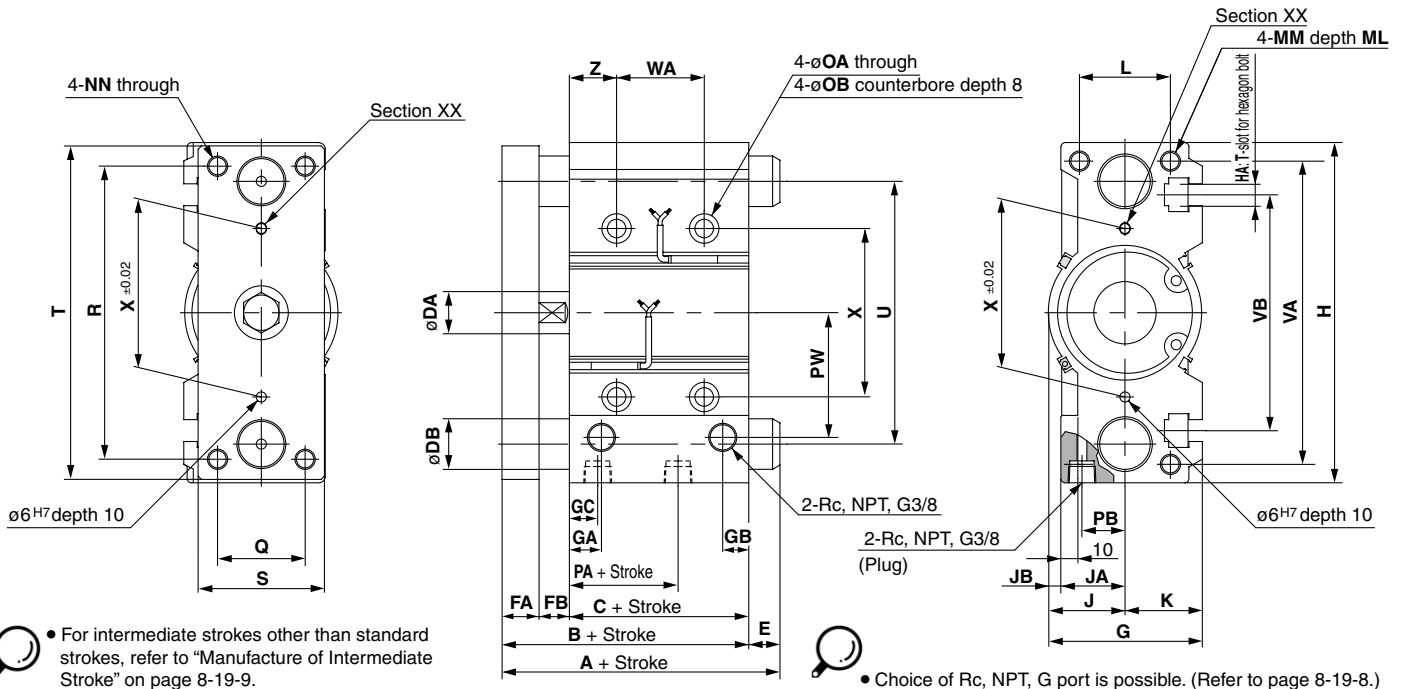

## MGPM, MGPL Common Dimensions

Bore size (mm)	Standard stroke (mm)	B	C	DA	FA	FB	G	GA	GB	GC	H	HA	J	JA	JB	K	L	MM	ML	NN	OA	OB	PA	PB	PW	Q	R
80	25, 50, 75, 100, 125, 150, 175, 200	96.5	56.5	25	22	18	91.5	19	15.5	14.5	202	M12	45.5	38	7.5	46	54	M12 x 1.75	25	M12 x 1.75	10.6	17.5	14.5	25.5	74	52	174
100	250, 300, 350, 400	116	66	30	25	25	111.5	23	19	18	240	M14	55.5	45	10.5	56	62	M14 x 2.0	31	M14 x 2.0	12.5	20	17.5	32.5	89	64	210

Bore size (mm)	S	T	U	VA	VB	WA				WB				X	YY	YL	Z		
						25 st or less	Over 25 st to 100 st	Over 100 st to 200 st	Over 200 st to 300 st	Over 300 st	25 st or less	Over 25 st to 100 st	Over 100 st to 200 st					Over 200 st to 300 st	Over 300 st
80	75	198	156	180	140	28	52	128	200	300	42	54	92	128	178	100	M12 x 1.75	24	28
100	90	236	188	210	166	48	72	148	220	320	35	47	85	121	171	124	M14 x 2.0	28	11

## MGPM (Slide bearing) A, DB, E Dimensions

Bore size (mm)	A			DB	E		
	50 st or less	Over 50 st to 200 st	Over 200 st		50 st or less	Over 50 st to 200 st	Over 200 st
80	115	142	193	30	18.5	45.5	96.5
100	137	162	203	36	21	46	87

## MGPL (Ball bushing bearing) A, DB, E Dimensions

Bore size (mm)	A				DB	E			
	25 st or less	Over 25 st to 50 st	Over 50 st to 200 st	Over 200 st		25 st or less	Over 25 st to 50 st	Over 50 st to 200 st	Over 200 st
80	109.5	130	160	193	25	13	33.5	63.5	96.5
100	121	147	180	203	30	5	31	64	87



# Made to Order Common Specifications: -XC8: Adjustable Stroke Cylinder/ Adjustable Extension Type

Symbol

## 16 Adjustable Stroke Cylinder/Adjustable Extension Type **-XC8**

It adjusts the extending stroke by the stroke adjustable mechanism equipped in the head side. (After the stroke is adjusted, with cushion on both sides is altered to single-sided, with cushion.)

### Applicable Series

Series	Description	Model	Action	Note	Vol. no. (for std model)
CJ2	Air cylinder	CJ2	Double acting, Single rod	Except with air cushion	6
CM2	Air cylinder	CM2	Double acting, Single rod		6
	Non-rotating rod type	CM2K	Double acting, Single rod		
	Direct mount type	CM2R	Double acting, Single rod		
	Cylinder with end lock	CBM2	Double acting, Single rod	Locking in head side only	
CG1	Air cylinder	CG1	Double acting, Single rod		6
	Non-rotating rod type	CG1K	Double acting, Single rod	Except with air cushion	
	Direct mount type	CG1R	Double acting, Single rod	Except with air cushion	
MB	Air cylinder	MB	Double acting, Single rod		6
	Non-rotating rod type	MBK	Double acting, Single rod		
MB1	Air cylinder	MB1	Double acting, Single rod		6
CA2	Air cylinder	CA2	Double acting, Single rod		6
	Non-rotating rod type	CA2K	Double acting, Single rod		
	Cylinder with end lock	CBA2	Double acting, Single rod	Locking in head side only	
CS1	Air cylinder	CS1	Double acting, Single rod		6
CQS	Compact cylinder	CQS	Double acting, Single rod	With rubber bumper, except with bracket	7
	Non-rotating rod	CQSK	Double acting, Single rod	With rubber bumper, except with bracket	
CQ2	Compact cylinder	CQ2	Double acting, Single rod	With rubber bumper, except with bracket	7
	Non-rotating rod type	CQ2K	Double acting, Single rod	With rubber bumper, except with bracket	
	Air-hydro type	CQ2H	Double acting, Single rod	With rubber bumper, except with bracket	
MTS	Precision cylinder	MTS	Double acting, Single rod		8
MGP	Compact guide cylinder	MGP	Double acting		8
		MGPA	High precision type		
MGG	Guide cylinder	MGG	Standard type		8
MGC		MGC	Compact type		8

### How to Order

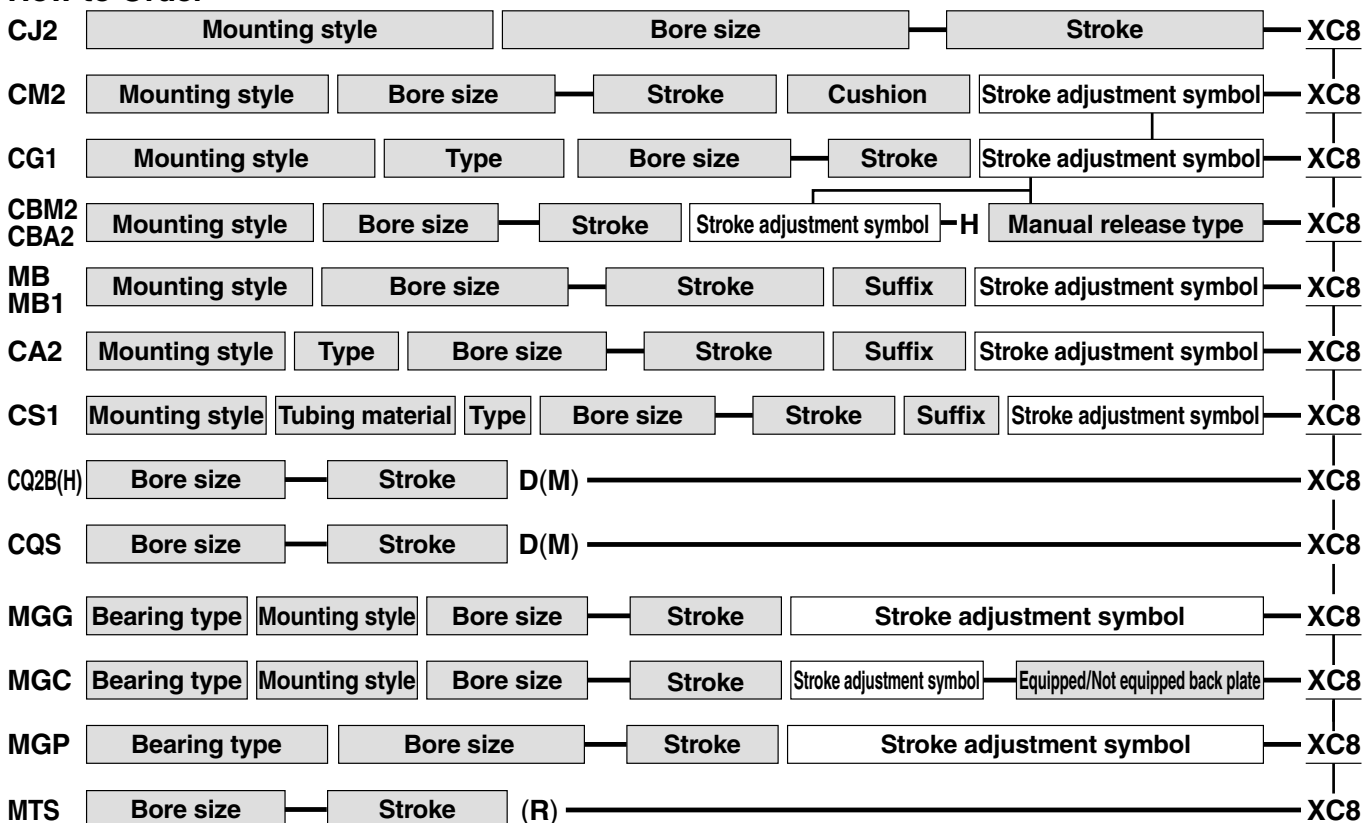

Adjustable stroke cylinder/Adjustable extend type •



- CJ1
- CJP
- CJ2
- CM2
- CG1
- MB
- MB1
- CA2
- CS1
- C76
- C85
- C95
- CP95
- NCM
- NCA
- D-
- X
- 20-
- Data

# Made to Order Common Specifications: -XC8: Adjustable Stroke Cylinder/ Adjustable Extension Type

## 16 Adjustable Stroke Cylinder/Adjustable Extension Type

### Specifications

Series	Stroke adjustment symbol	Stroke adjustment range (mm)
CJ2	—	0 to 15
CM2 CG1 MB MB1 CA2 CS1	A	0 to 25
	B	0 to 50

Note) Specifications other than above are the same as standard type.

Series	Stroke adjustment symbol	Stroke adjustment range (mm)
CQ2 CQS	—	0 to 10
MGG MGC	A	0 to 25
	B	0 to 50
MGP	A	0 to 10
	B	0 to 25
MTS	—	0 to 10 (ø8)
		0 to 25 (ø12 to ø40)

### Warning Precautions

- When the cylinder is operating, if something gets caught between the stopper bracket for adjusting the stroke and the cylinder body, it could injure personnel or damage the peripheral equipment. Therefore, take preventive measures as necessary, such as installing a protective cover.
- To adjust the stroke, make sure to secure the wrench flats of the stopper bracket before loosening the nut. If the nut is loosened without securing the stopper bracket, be aware that the area that joins the load to the piston rod or the area in which the piston rod is joined with the load side and the stopper bracket side could loosen first.

### JIS Symbol

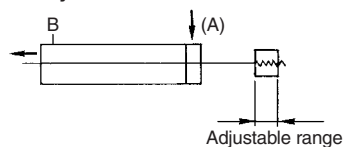

# Made to Order Common Specifications: -XC8: Adjustable Stroke Cylinder/ Adjustable Extension Type

## 16 Adjustable Stroke Cylinder/Adjustable Extension Type

Symbol  
**-XC8**

**Dimensions** (Dimensions other than below are the same as standard type.)

### Series MGG

ø20 to ø50

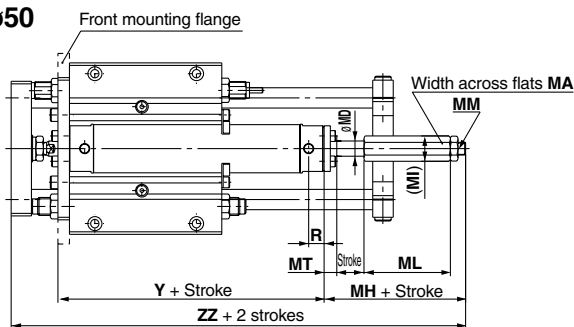

ø63

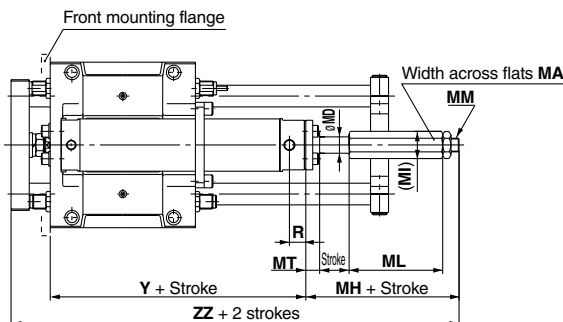

### MGG, MGC Common

Bore size (mm)	R	Y	MA	MD	MI	MM	MT
20	12	86	14	8	16.2	M8 x 1.25	9
25	12	86	17	10	19.7	M10 x 1.25	11
32	12	88	17	12	19.7	M10 x 1.25	11
40	13	99	24	16	27.8	M14 x 1.5	11
50	14	114	32	20	37	M18 x 1.5	11
63*	14	117	32	20	37	M18 x 1.5	13

\* Series MGG only

Bore size (mm)	Adjustment 0 to 25 mm			Adjustment 0 to 50 mm		
	MH	ML	ZZ	MH	ML	ZZ
20	63	43	179	88	68	204
25	66	43	189	91	68	214
32	66	43	191	91	68	216
40	72	47	215	97	72	240
50	85	53	254	110	78	279
63*	85	53	256	110	78	281

\* Series MGG only

### Series MGC

ø20 to ø50

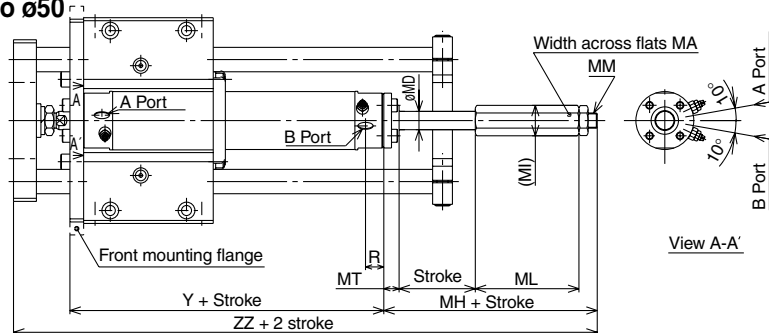

### Series MGP

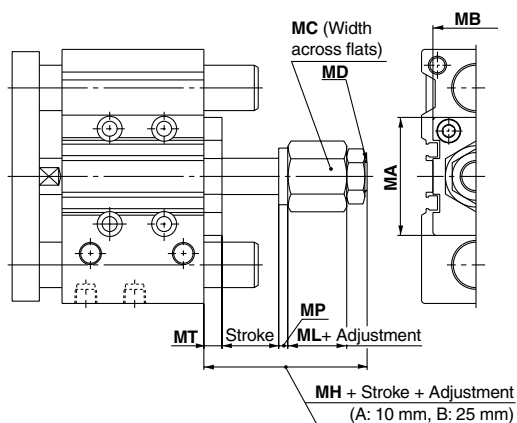

### MGPM, MGPL Common Dimensions

Bore size (mm)	MA	MB	MC	MD	MH	ML	MP	MT
12	28	16	14	M5 x 0.8	22	9	3	5
16	29	19	14	M5 x 0.8	22	9	3	5
20	34	30	22	M8 x 1.25	30	12.5	3	8
25	40	30	22	M8 x 1.25	30	12.5	3	8
32	52	38	27	M14 x 1.5	37	16	4	8
40	60	38	27	M14 x 1.5	37	16	4	8
50	68	50	36	M18 x 1.5	47	20	4	9
63	84	50	36	M18 x 1.5	47	20	4	9
80	114	50	46	M22 x 1.5	58	28	4	12
100	140	65	46	M22 x 1.5	62	28	4	16



# Made to Order Common Specifications: -XC9: Adjustable Stroke Cylinder/ Adjustable Retraction Type

## 17 Adjustable Stroke Cylinder/Adjustable Retraction Type

Symbol  
-XC9

The retract stroke of the cylinder can be adjusted by the adjusting bolt.

### Applicable Series

Series	Description	Model	Action	Note	Vol. no. (for std model)
CJ2	Air cylinder	CJ2	Double acting, Single rod	Except with air cushion	6
CM2	Air cylinder	CM2	Double acting, Single rod		6
	Non-rotating rod	CM2K	Double acting, Single rod		
	Direct mount type	CM2R	Double acting, Single rod		
	Non-rotating rod/Direct mount type	CM2RK	Double acting, Single rod		
CG1	Air cylinder	CG1	Double acting, Single rod		6
	Non-rotating rod	CG1K	Double acting, Single rod	Except with air cushion	
	Direct mount type	CG1R	Double acting, Single rod	Except with air cushion	
MB	Air cylinder	MB	Double acting, Single rod		6
	Low friction	MB□Q	Double acting, Single rod		
	Non-rotating rod	MBK	Double acting, Single rod		
MB1	Air cylinder	MB1	Double acting, Single rod		6
CA2	Air cylinder	CA2	Double acting, Single rod		6
	Non-rotating rod	CA2K	Double acting, Single rod		
CS1	Air cylinder	CS1	Double acting, Single rod		6
CQS	Compact cylinder	CQS	Double acting, Single rod	Except with rubber bumper and with bracket	7
CQ2	Compact cylinder	CQ2	Double acting, Single rod	Except with rubber bumper and with bracket	7
	Non-rotating rod	CQ2K	Double acting, Single rod	Except with rubber bumper and with bracket	
MGP	Compact guide cylinder	MGP	Double acting		8
		MGPA	High precision type		
MGG	Guide cylinder	MGG	Standard type		8
MGC		MGC	Compact type		8

### How to Order

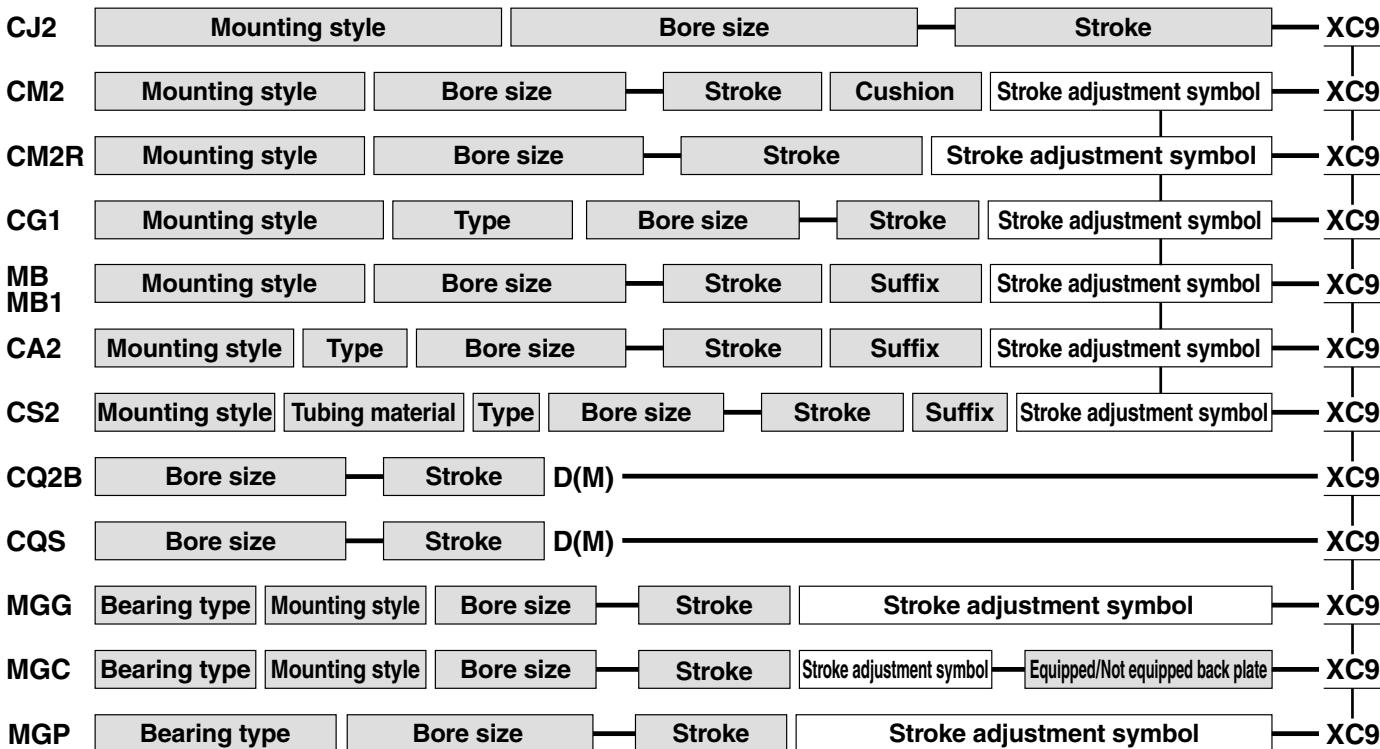

Adjustable stroke cylinder/Adjustable retract type

(After adjusting stroke, both-side cushion style is changed into single side cushion style. CQ2 is without cushion.)

# Made to Order Common Specifications: -XC9: Adjustable Stroke Cylinder/ Adjustable Retraction Type

## 17 Adjustable Stroke Cylinder/Adjustable Retraction Type

### Specifications

Series	Stroke adjustment symbol	Stroke adjustment range (mm)
CJ2	—	0 to 15
CM2 CG1 MB MB1 CA2 CS1	A	0 to 25
	B	0 to 50

Note) Specifications other than above are the same as standard type.

Series	Stroke adjustment symbol	Stroke adjustment range (mm)
CQ2 CQS	—	0 to 10
MGG MGC	A	0 to 25
	B	0 to 50
MGP	A	0 to 10
	B	0 to 25

### ⚠ Caution Precautions

- When air is supplied to the cylinder, if the stroke adjusting bolt is loosened in excess of the allowable stroke adjustment amount, be aware that the stroke adjusting bolt could fly out or air could be discharged, which could injure personnel or damage the peripheral equipment.
- Adjust the stroke when the cylinder is not pressurized.  
If it is adjusted in the pressurized state, the seal of the adjustment section could become deformed, leading to air leakage.

#### JIS Symbol

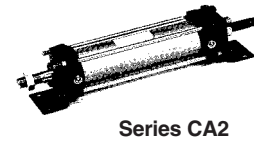
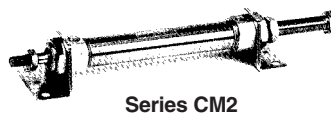
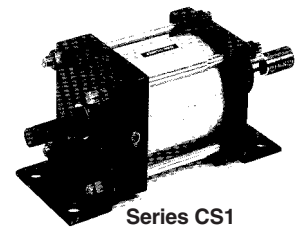
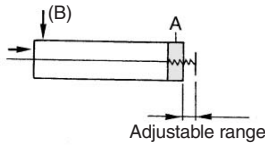

**Dimensions** (Dimensions other than below are the same as standard type.)

**Series MGG**  
ø20 to ø50

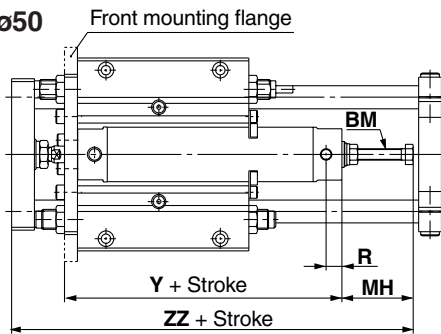

**MGG, MGC Common**

Bore size (mm)	R	Y	BM	MGG				MGC			
				Adjustment 0 to 25 mm		Adjustment 0 to 50 mm		Adjustment 0 to 25 mm		Adjustment 0 to 50 mm	
				MH	ZZ	MH	ZZ	MH	ZZ	MH	ZZ
20	12	86	M6 x 1	48	164	73	189	46	162	71	187
25	12	86	M6 x 1	48	171	73	196	46	169	71	194
32	12	88	M8 x 1.25	50	175	75	200	50	175	75	200
40	13	99	M12 x 1.75	65	208	90	233	64	207	89	232
50	14	114	M12 x 1.75	58	227	83	252	62	231	87	256
63	14	117	M16 x 2	65	236	90	261	—	—	—	—

ø63

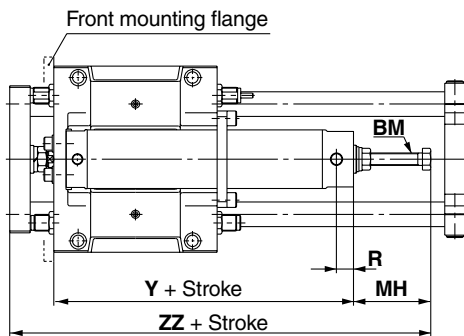

**Series MGC**  
ø20 to ø50

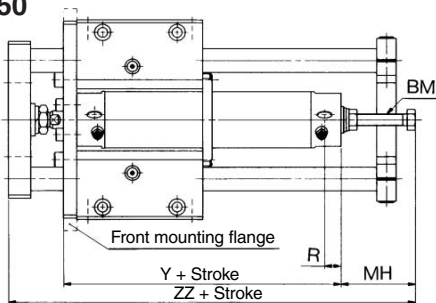

**Series MGP**

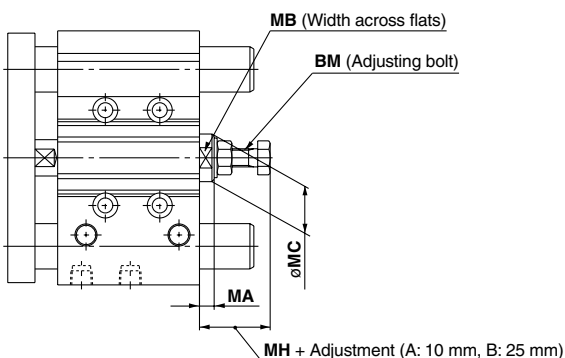

**MGPM, MGPL**  
Common Dimensions

Bore size (mm)	BM	MA	MB	MC	MH
12	M5 x 0.8	5	8	12.5	19
16	M6 x 1.0	5	10	14	19
20	M8 x 1.25	6.5	13	17.5	27
25	M8 x 1.25	6.5	13	17.5	26.5
32	M8 x 1.25	6.5	19	21	26.5
40	M12 x 1.5	9	27	30	33
50	M12 x 1.5	9	30	34	32.5
63	M16 x 1.5	10	36	40	37
80	M20 x 1.5	15	41	46	53.5
100	M24 x 1.5	18	46	52	57.5

CJ1

CJP

CJ2

CM2

CG1

MB

MB1

CA2

CS1

C76

C85

C95

CP95

NCM

NCA

D-

-X

20-

Data