

Turntable Cylinder

Series MGT

ø63, ø80, ø100

How to Order

MGT M 63 50 11 Y59A S A93 S

Cylinder with turntable

Guide rod bearing type

M	Slide bearing
L	Ball bushing

Bore size

63	63mm
80	80mm
100	100mm

Stroke (mm)
Refer to standard stroke table on page 2.

Table position detector hardware

Symbol	Positioning angle	Switch bracket	Position detector arms			
			a	b	c	d
10	90°	X	X	X	X	X
11		○	○	○	○	○
12		○	○	○	○	X
13		○	○	X	○	X
14		○	○	○	X	X
15	○	○	X	X	X	
20	180°	X	X	X	X	X
23		○	○	X	○	X
25		○	○	X	X	X

Table unit auto switch type

Nil	Without auto switch
------------	---------------------

Table unit switch quantity

S	1 pc.
2	2 pcs.
3	3 pcs.
4	4 pcs.

Cylinder unit auto switch type

Nil	Without auto switch
------------	---------------------

Cylinder unit switch quantity

Nil	2 pcs.
S	1 pc.

Diagram: Shows a turntable cylinder with a switch mounting bracket (a), table position detector arm (d), and guide rod bearing type (c, b).

Cylinder unit/Applicable auto switch types

Type	Special functions	Electrical entry	Indicator light	Wiring (output)	Load voltage		Auto switch part no.		Lead wire length (m)			Applicable load		
					DC	AC	Electrical entry direction	Vertical	Horizontal	0.5 (Nil)	3 (L)	5 (Z)	IC circuit	Relay PLC
Reed switch	—	Grommet	Yes	3 wire	—	5V	—	—	Z76	●	●	—	IC circuit	—
				2 wire	24V	12V	100V	—	Z73	●	●	●	—	Relay PLC
				2 wire	—	5V	100V or less	—	Z80	●	●	—	IC circuit	—
Solid state switch	—	Grommet	Yes	3 wire (NPN)	24V	5V	—	Y69A	Y59A	●	●	○	IC circuit	Relay PLC
				3 wire (PNP)				Y7PV	Y7P	●	●	○	IC circuit	
				2 wire				Y69B	Y59B	●	●	○	—	
	3 wire (NPN)	Y7NWV	Y7NW	●	●	○	IC circuit							
	3 wire (PNP)	Y7PWV	Y7PW	●	●	○	IC circuit							
	2 wire	Y7BWV	Y7BW	●	●	○	—							
Diagnostic indicator (2 color indicator)	—	Grommet	Yes	3 wire (NPN)	24V	5V	—	Y69A	Y59A	●	●	○	IC circuit	Relay PLC
				3 wire (PNP)				Y7PV	Y7P	●	●	○	IC circuit	
				2 wire				Y69B	Y59B	●	●	○	—	
Diagnostic indicator (2 color indicator)	—	Grommet	Yes	3 wire (NPN)	24V	12V	—	Y7NWV	Y7NW	●	●	○	IC circuit	Relay PLC
				3 wire (PNP)				Y7PWV	Y7PW	●	●	○	IC circuit	
				2 wire				Y7BWV	Y7BW	●	●	○	—	

* Lead wire indicator symbol
0.5m Nil (Ex.) Y69B
3m L Y69BL
5m Z Y69BZ

** Solid state auto switches marked with a ○ are manufactured upon receipt of order.

*** Refer to pages 6 to 9 for detailed auto switch specifications.

Table unit/Applicable auto switch types

Type	Special functions	Electrical entry	Indicator light	Wiring (output)	Load voltage		Auto switch part no.		*Lead wire length (m)		Applicable load		
					DC	AC	Electrical entry direction	Horizontal	0.5 (Nil)	3 (L)	IC circuit	Relay PLC	
Reed switch	—	Grommet	No	2 wire	24V	5V, 12V	100V or less	A90	●	●	—	IC circuit	Relay PLC
				2 wire	—	12V	100V	A93	●	●	—	IC circuit	—
				3 wire (NPN equiv.)	—	5V	—	A96	●	●	—	IC circuit	—
Solid state switch	—	Grommet	Yes	3 wire (NPN)	24V	12V	—	F9N	●	●	—	Relay PLC	
				3 wire (PNP)				F9P	●	●	—		
				2 wire				F9B	●	●	—		
	3 wire (NPN)	F9NW	●	●	—								
	3 wire (PNP)	F9PW	●	●	—								
	2 wire	F9BW	●	●	—								
Diagnostic indicator (2 color indicator)	—	Grommet	Yes	3 wire (NPN)	24V	12V	—	F9N	●	●	—	Relay PLC	
				3 wire (PNP)				F9P	●	●	—		
				2 wire				F9B	●	●	—		
Diagnostic indicator (2 color indicator)	—	Grommet	Yes	3 wire (NPN)	24V	12V	—	F9NW	●	●	—	Relay PLC	
				3 wire (PNP)				F9PW	●	●	—		
				2 wire				F9BW	●	●	—		

* Lead wire length indicator symbol
0.5m Nil (Ex.) A93
3m L A93L

** Refer to pages 6 to 9 for detailed auto switch specifications.

Series MGT



Models

Model	Bearing type	Bore size (mm)	Applicable auto switches			
			Cylinder		Turntable	
			Reed switch	Solid state	Reed switch	Solid state
MGTM	Slide bearing	63	D-Z7 type D-Z8 type	D-Y5 type	Note 1) D-A9 type	Note 1) D-F9 type
		80		D-Y6 type		
MGTL	Ball bushing	100		D-Y7 type		

Note 1) Vertical outlet types cannot be mounted.

Specifications

1MPa = 10.2kgf/cm²

Actuation system	Double acting type
Fluid	Air
Proof pressure	1.5MPa{15.3kgf/cm ² }
Maximum operating pressure	1.0MPa{10.2kgf/cm ² }
Minimum operating pressure	0.1MPa{1.0kgf/cm ² }
Ambient & fluid temperatures	-10 to 60°C
Piston speed	50 to 400mm/s
Bumper	Double-side rubber bumper
Lubrication	Non-lube
Stroke length tolerance	+1.5 0 mm
Table rotation system	Manual type
Table rotation direction	Right, left, free repetitive rotation
Table angle of rotation	Quarter circle 90°, half circle 180°, with positioning mechanism

Standard Stroke Table

Model	Standard strokes (mm)
MGTM 63	25, 50, 75, 100, 125,
MGTL 80	150, 175, 200
MGTL 100	

Intermediate strokes

Intermediate strokes (in 5mm increments) other than the standard strokes are made by installing spacers of 5, 10, 15 and 20mm widths.

(Ex.) A 1.MGTM63-35st is made by installing a 15mm spacer inside a MGTM63-50st, however the overall length will be the same as the 50st.

Theoretical Output

Bore size (mm)	Rod size (mm)	Actuation direction	Piston area (mm ²)	Operating pressure (MPa)								
				0.2	0.3	0.4	0.5	0.6	0.7	0.8	0.9	1.0
63	20	OUT	3117	623	935	1247	1559	1870	2182	2494	2805	3117
		IN	2803	561	841	1121	1402	1682	1962	2242	2523	2803
80	25	OUT	5027	1005	1508	2011	2514	3016	3519	4022	4524	5027
		IN	4536	907	1361	1814	2268	2722	3175	3629	4082	4536
100	30	OUT	7854	1571	2356	3142	3927	4712	5498	6283	7069	7854
		IN	7147	1429	2144	2859	3574	4288	5003	5718	6432	7147

1N: Approx. 0.102kgf 1MPa: Approx. 1.02kgf/cm² Note) Theoretical output (N) = Pressure (MPa) x Piston area (mm²)

Additional Bracket Weight Table

Bore size (mm)	Symbols for table unit position detector bracket (kg)					
	10 11 12 13 14 15					
	20 — — 23 — 25					
63	0	0.21	0.16	0.12	0.12	0.08
80	0	0.24	0.19	0.14	0.13	0.08
100	0	0.25	0.19	0.14	0.14	0.09

Weight Table

MGTM63 to 100 (Slide bearing)

Bore size (mm)	Model	Standard stroke (mm)							
		25	50	75	100	125	150	175	200
63	MGTM63	6.96 (4.78)	7.81 (5.12)	8.57 (5.38)	9.32 (5.63)	10.08 (5.88)	10.83 (6.14)	11.59 (6.39)	13.10 (6.90)
80	MGTM80	12.07 (9.29)	13.31 (9.96)	14.25 (10.33)	15.18 (10.71)	16.12 (11.08)	17.06 (11.46)	18.00 (11.83)	19.87 (12.58)
100	MGTM100	17.83 (13.51)	19.56 (14.45)	20.89 (14.99)	22.22 (15.53)	23.55 (16.07)	24.88 (16.60)	26.21 (17.14)	28.87 (18.22)

MGTL63 to 100 (Ball bushing)

Bore size (mm)	Model	Standard stroke (mm)							
		25	50	75	100	125	150	175	200
63	MGTL63	6.62 (4.33)	7.49 (4.61)	8.15 (4.80)	8.91 (5.08)	9.57 (5.27)	10.24 (5.45)	10.90 (5.64)	12.23 (6.01)
80	MGTL80	12.03 (8.92)	13.33 (9.44)	14.15 (9.73)	14.97 (10.02)	15.79 (10.31)	16.61 (10.60)	17.43 (10.89)	19.07 (11.46)
100	MGTL100	17.53 (12.84)	19.33 (13.62)	20.51 (14.04)	21.69 (14.46)	22.87 (14.87)	24.04 (15.29)	25.22 (15.70)	27.58 (16.54)

Numbers inside () indicate the weight of moving parts.

Operating Conditions

Allowable eccentric load

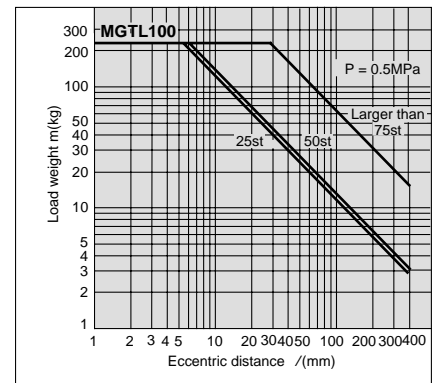
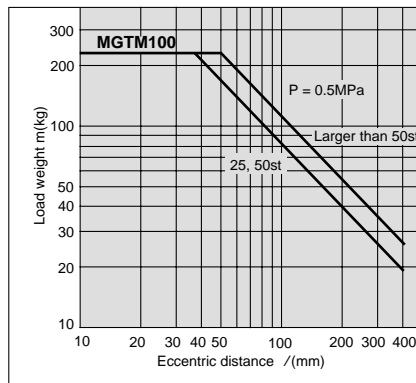
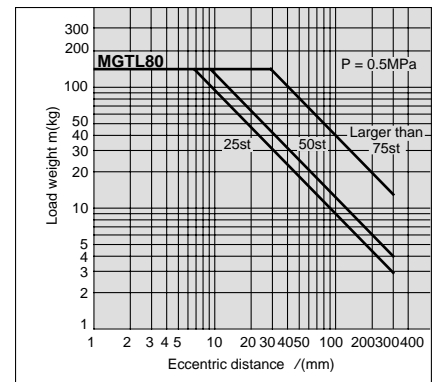
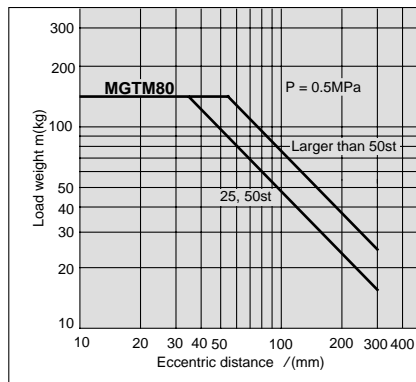
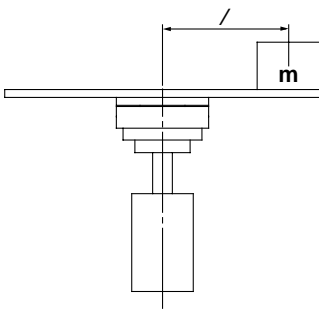
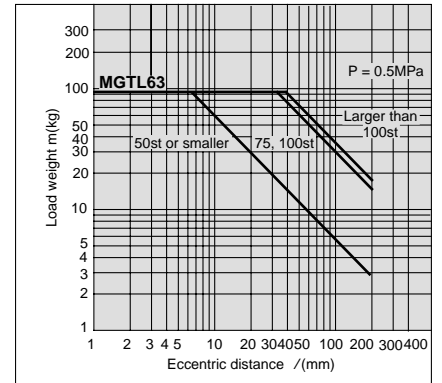
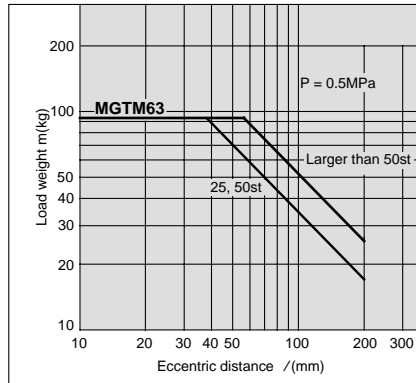
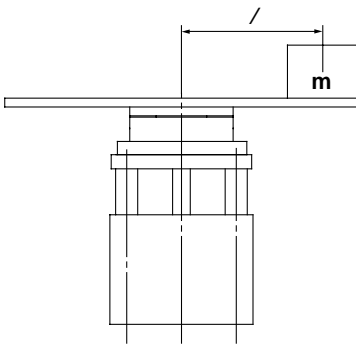

Allowable side load

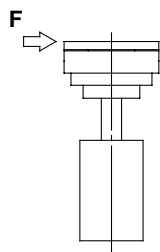
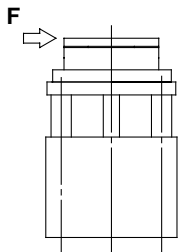

F(N) 1N: Approx. 0.102kgf

Bore size (mm)	Model	Stroke (mm)							
		25	50	75	100	125	150	175	200
63	MGTM	204	178	212	193	176	162	151	140
	MGTL	143	127	186	170	243	226	212	199
80	MGTM	250	221	291	267	246	228	213	199
	MGTL	62	154	255	237	220	205	192	180
100	MGTM	356	321	382	353	328	307	288	271
	MGTL	114	153	335	313	292	274	257	242

Series MGT

Construction

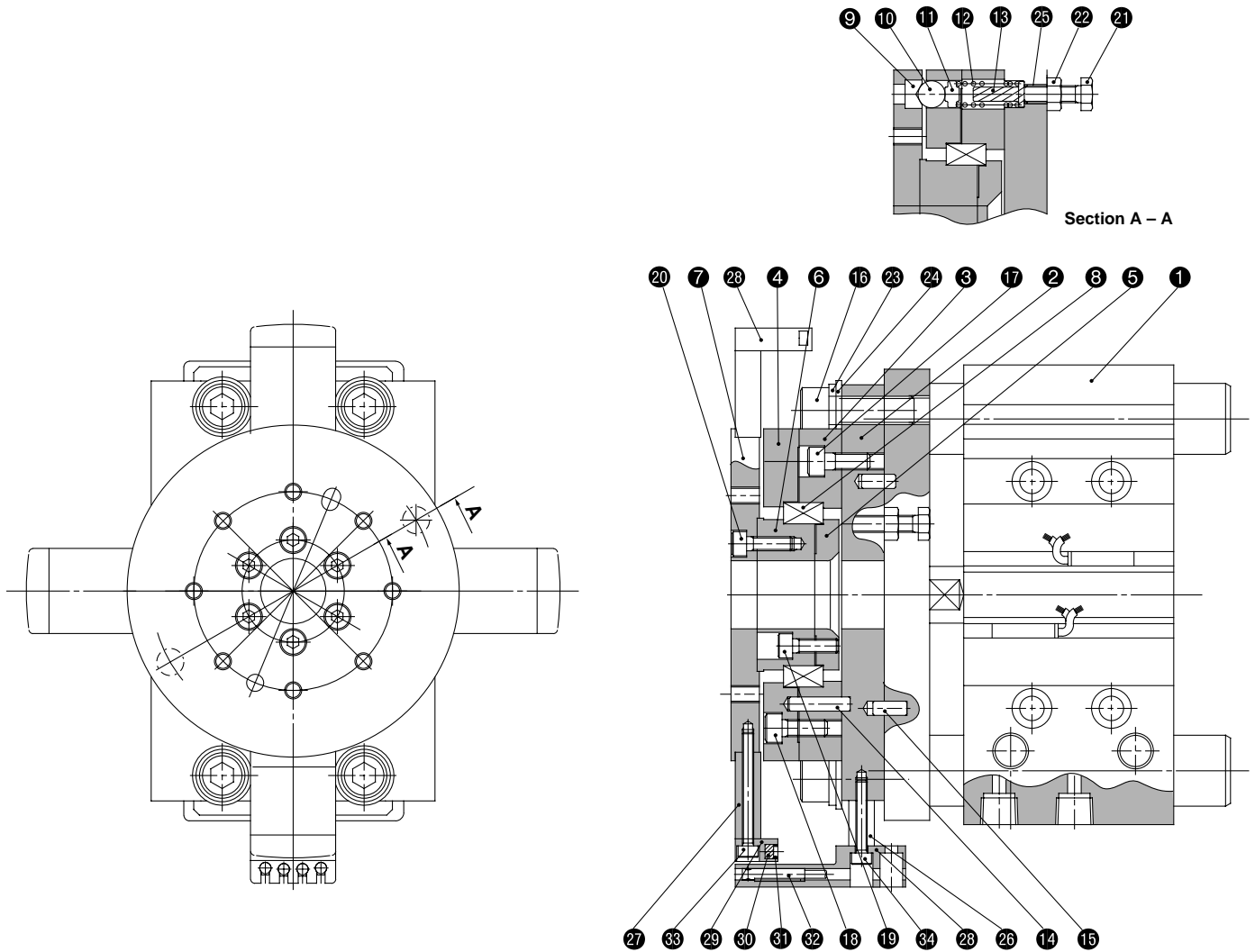

Parts list

No.	Description	Material	Note
1	Flat cylinder w/turntable	MGTM	MGPM63 to 100-□-□
		MGTL	MGPL63 to 100-□-□
2	Guide plate	Aluminum alloy	White anodized
3	Bearing guide A	Aluminum alloy	White anodized
4	Bearing guide B	Aluminum alloy	White anodized
5	Bearing guide C	Aluminum alloy	Chromated
6	Bearing guide D	Aluminum alloy	Chromated
7	Notch table	Carbon steel	Nickel plated
8	Bearing	—	
9	Notch ring	Carbon steel	Hard zinc chromated
10	Steel ball	High carbon chromium bearing steel	
11	Ball cap	Stainless steel	
12	Return spring	Piano wire	Zinc chromated

Parts list (position detector bracket)

No.	Description	Material	Note
26	Magnet base A	Aluminum alloy	White anodized
27	Magnet base B	Aluminum alloy	White anodized
28	Switch holder	Aluminum alloy	White anodized
29	Magnet holder	Aluminum alloy	White anodized
30	Magnet	Rare earth magnet	
31	Retaining ring	Carbon tool steel	
32	Auto switch	—	D-A9 type
33	Hexagon socket head cap screw	Chrome molybdenum steel	Nickel plated
34	Hexagon socket head cap screw	Chrome molybdenum steel	Nickel plated

Parts list

No.	Description	Material	Note
13	Spring guide	Carbon steel	
14	Parallel pin	High carbon chromium bearing steel	
15	Parallel pin	High carbon chromium bearing steel	
16	Hexagon socket head cap screw	Chrome molybdenum steel	Nickel plated
17	Hexagon socket head cap screw	Chrome molybdenum steel	Nickel plated
18	Hexagon socket head cap screw	Chrome molybdenum steel	Nickel plated
19	Hexagon socket head cap screw	Chrome molybdenum steel	Nickel plated
20	Hexagon socket head cap screw	Chrome molybdenum steel	Nickel plated
21	Hexagon bolt	Chrome molybdenum steel	Nickel plated
22	Hexagon nut	Carbon steel	Nickel plated
23	Spring washer	Steel wire	Nickel plated
24	Plain washer	Carbon wire	Nickel plated
25	Helical insert	Stainless steel	

Note) Please refer to the separate catalog CAT.E250 for details on components and replaceable parts for flat cylinders with guides (MGPM, MGPL).

Dimensions

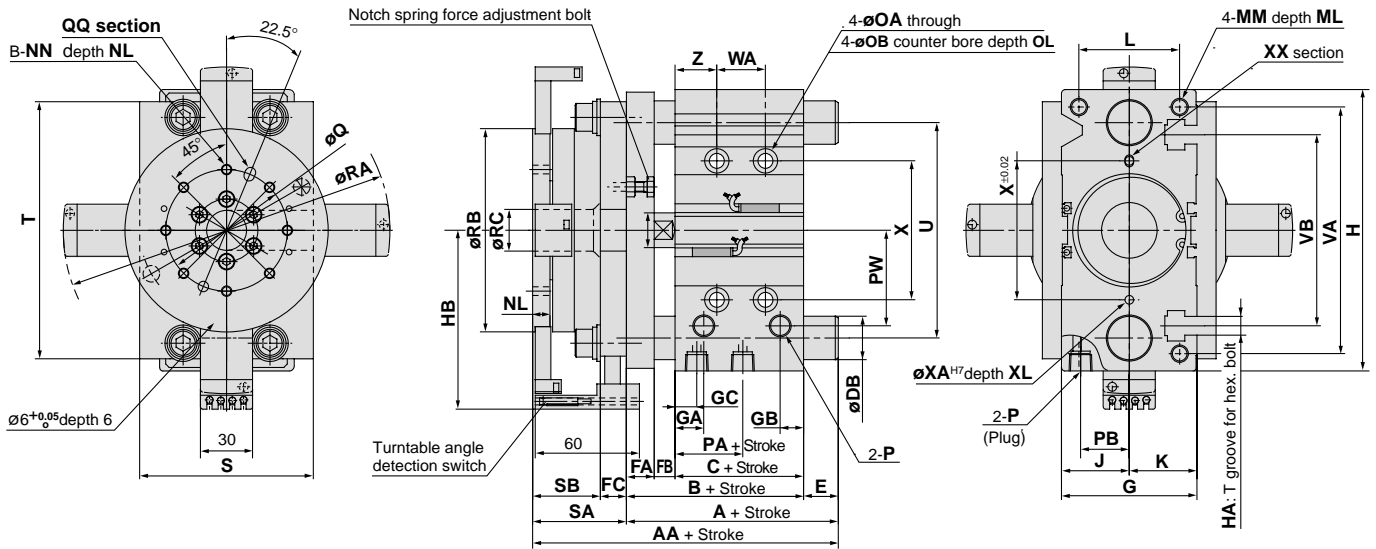
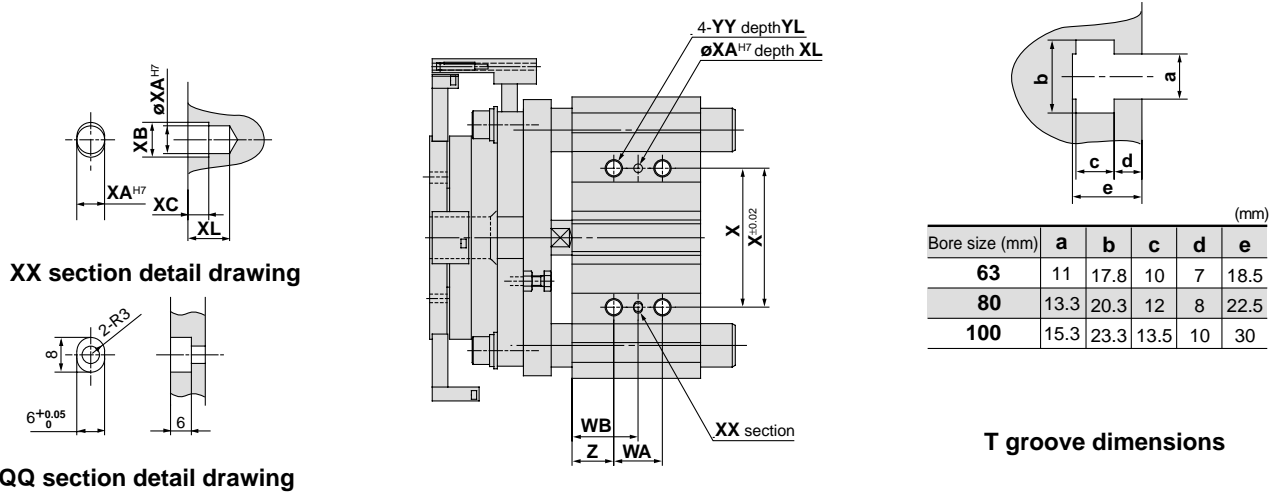

Bore size (mm)	Standard stroke (mm)	B	C	DA	FA	FB	FC	G	GA	GB	GC	H	HA	HB	J	K	L	MM	ML	NN	NL	OA
63	25, 50, 75,	77	49	20	16	12	15	78	16.5	13.5	16.5	162	M10	103	39	39	58	M10 X 1.5	22	M6 X 1.0	10	8.6
80	100, 125, 150,	96.5	56.5	25	22	18	15	91.5	19	15.5	14.5	202	M12	121.5	45.5	46	54	M12 X 1.75	26	M8 X 1.25	12	10.6
100	175, 200	116	66	30	25	25	20	111.5	23	19	18	240	M14	145	55.5	56	62	M14 X 2.0	32	M8 X 1.25	15	12.5

Bore size (mm)	OB	OL	P	PA	PB	PW	Q	RA	RB	RC	S	SA	SB	T	U	VA	VB	WA			WB		
																		25st	50, 75, 100st	Larger than 100st	25st	50, 75, 100st	Larger than 100st
63	14	9	Rc1/4	14	28	55	70	188	117	24	100	54	39	148	124	142	110	28	52	128	38	50	88
80	17.5	8	Rc3/8	14.5	25.5	74	80	225	128	24	125	56	41	198	156	180	140	28	52	128	42	54	92
100	20	8	Rc3/8	17.5	32.5	89	100	272	168	35	150	71	51	236	188	210	166	48	72	148	35	47	85

Bore size (mm)	X	XA	XB	XC	XL	YY	YL	Z
63	80	5	6	4	8	M10 X 1.5	20	24
80	100	6	7	5	10	M12 X 1.75	24	28
100	124	6	7	5	10	M14 X 2.0	28	11

MGTM (Slide bearing)

Bore size (mm)	AA				BD	E	
	25.50st	Larger than 50st	25.50st	Larger than 50st		25.50st	Larger than 50st
63	160.5	172	106.5	118	25	29.5	41
80	171	198	115	142	30	18.5	45.5
100	208	233	137	162	36	21	46

MGTL (Ball bushing)

Bore size (mm)	AA			A				DB	E			
	25st	50st	75st, 100st	25st	50st	75st, 100st	Larger than 100st		25st	50st	75st, 100st	Larger than 100st
63	147	168	188	93	114	134	20	16	37	57		
80	165.5	186	216	109.5	130	160	25	13	33.5	63.5		
100	192	218	251	121	147	180	30	5	31	64		

Auto Switch Specifications

Applicable Auto Switch Models



Applicable auto switches		Electrical entry/Function
Reed switches	D-Z7-Z8 type	Grommet
	D-A9 □ type	Grommet
Solid state switches	D-Y5-Y6-Y7P(V) type	Grommet
	D-Y7 □ W(V) type	Grommet (2 color indicator type, with diagnostic output)
	D-F9 □ type	Grommet
	D-F9 □ W type	Grommet (2 color indicator type, with diagnostic output)

⚠ Specific Product Precautions

Be sure to read before handling.
Refer to pages 13 through 15 for auto switch precautions.

Contact Protection Box/CD-P11, CD-P12

The D-Z7, D-Z8 and D-A9 type switches do not have built-in contact protection circuits. Use a contact protection box in cases such as with an induction load, when the lead wire is longer than 5m or with 100VAC.

- 1 Operating load is an induction load.
- 2 Wiring to the load is 5m or longer.
- 3 Load voltage is 100VAC.

Use a contact protection box in any of the above listed situations.

Contact protection box specifications

Part number	CD-P11		CD-P12
Load voltage	100VAC or less	200VAC	24VDC
Max. load current	25mA	12.5mA	50mA

* Lead wire length ----- Switch contact side 0.5m
Load connection side 0.5m



Contact protection box internal circuits

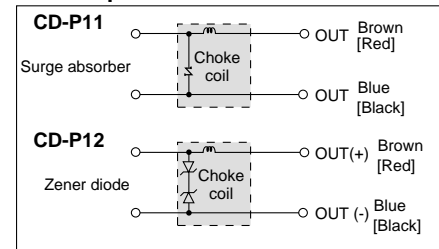

Contact protection box/Dimensions

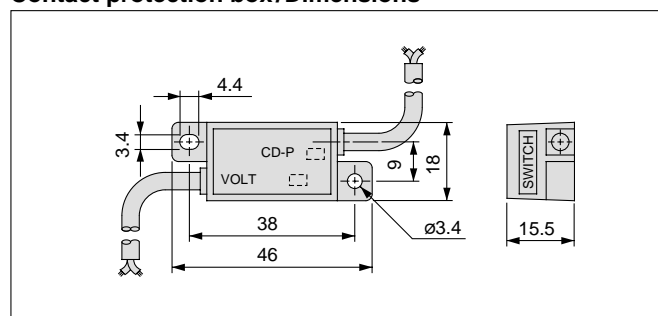

Contact protection box/Connection method

In order to connect a switch unit to a contact protection box, connect the lead wires from the contact protection box on the side labeled SWITCH to the lead wires coming out of the switch unit. Further, the length of the lead wires between the contact protection box and the switch unit should be kept as short as possible, but no more than 1m.

Auto Switch Internal Circuits

Reed switches

D-Z73

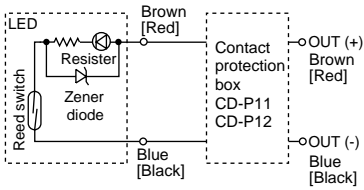

D-Z76

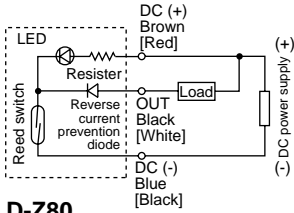

D-Z80

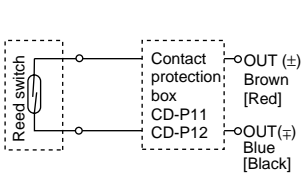

D-A90(V)

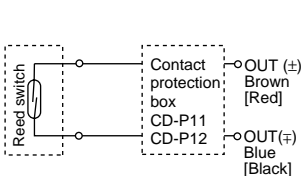

D-A93(V)

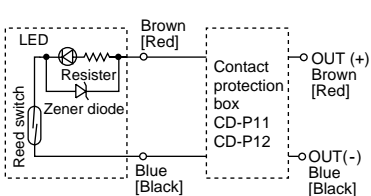

D-A96(V)

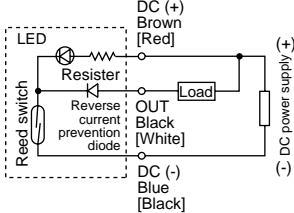

Solid state switches

D-Y59A, Y69A

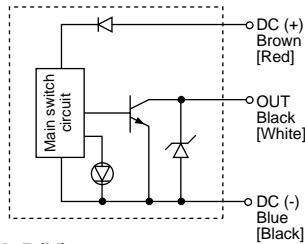

D-Y7P(V)

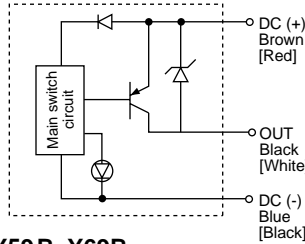

D-Y59B, Y69B

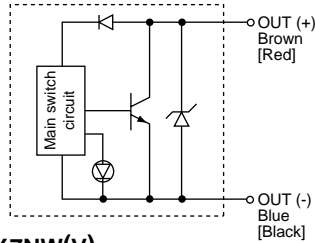

D-Y7NW(V)

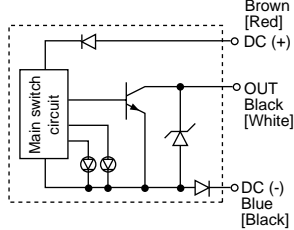

D-Y7PW(V)

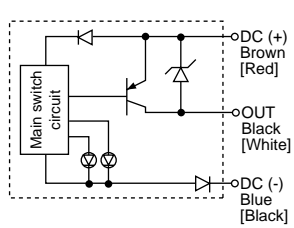

D-Y7BW(V)

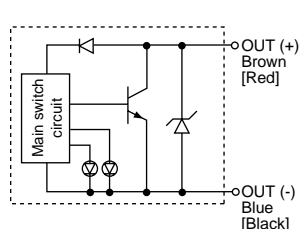

D-F9N(V)

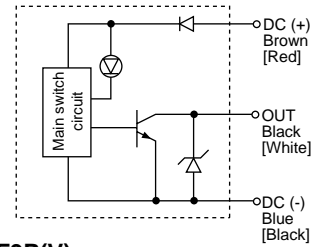

D-F9P(V)

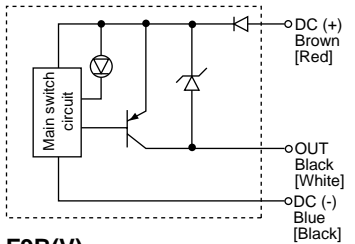

D-F9B(V)

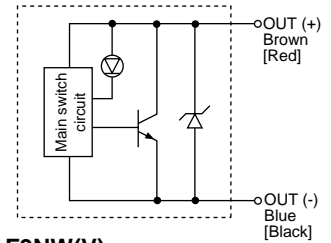

D-F9NW(V)

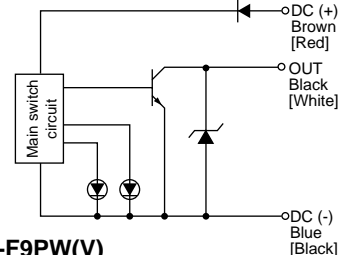

D-F9PW(V)

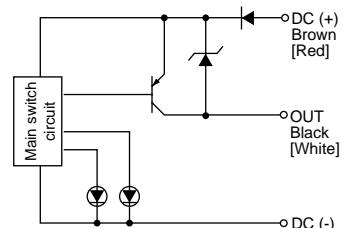

D-F9BW(V)

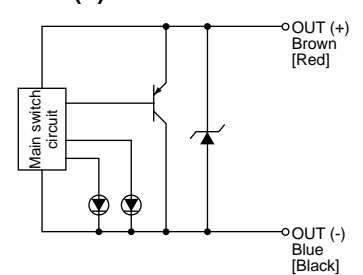

Indicator light/Display method

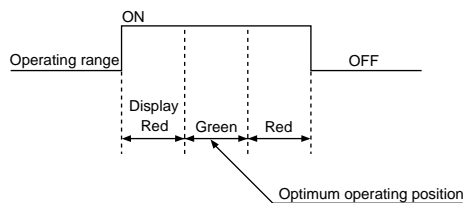

Series MGT

Proper Auto Switch Mounting Positions (Stroke End)

Proper auto switch mounting positions for cylinders (stroke end)

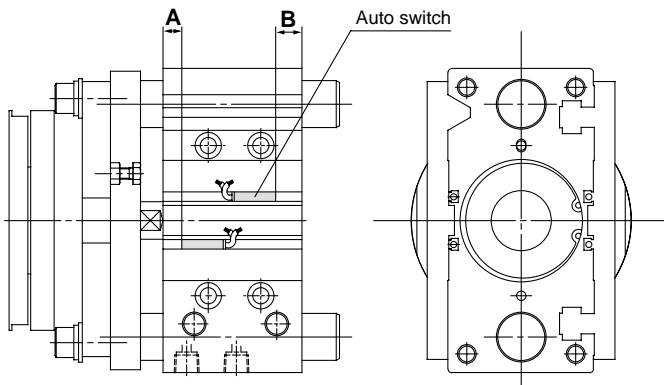

Proper mounting positions (mm)

Bore size (mm)	A	B
63	10	14
80	13	18.5
100	17.5	23.5

Proper auto switch mounting positions for table position detection

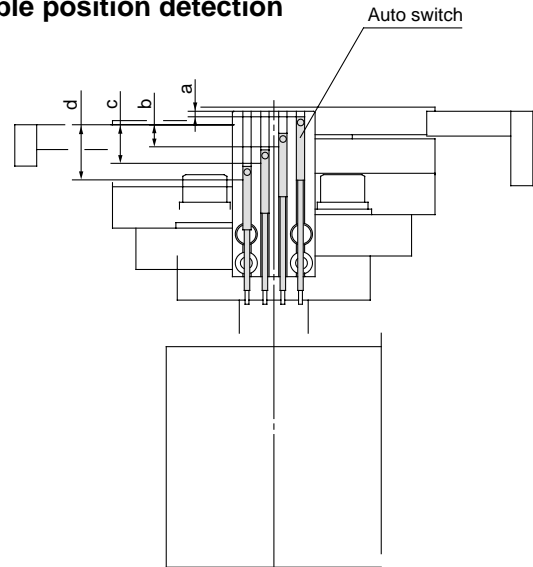

Proper mounting positions (mm)

	a	b	c	d
D-A9 type	2	8	14	20
D-F9 type	6	12	18	24
D-F9 □ W type	5	11	17	23

In order that adjacent switches do not misoperate, they should be set within ± 1 mm of the proper mounting positions indicated in the table above.

Mounting of Auto Switches

When mounting an auto switch, insert it into the cylinder's switch groove from the direction shown in the figure below. After setting it in the mounting position, use a flat head watchmakers screwdriver to secure it with the mounting screw which is included.

Mounting of auto switches for cylinders

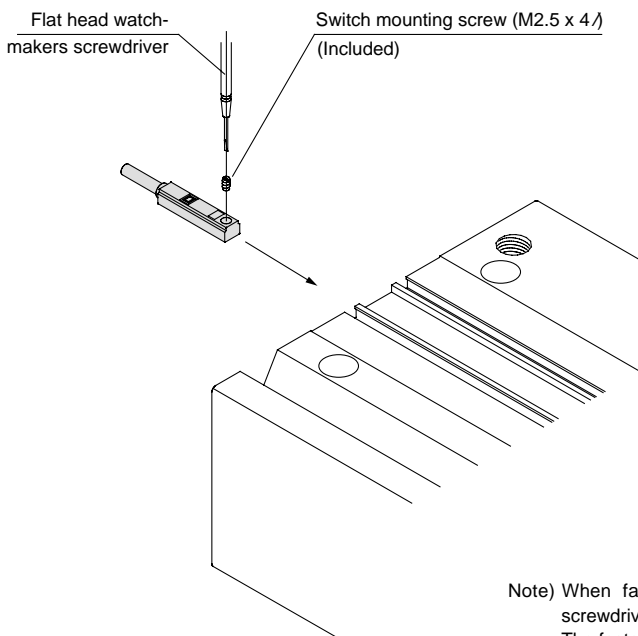

Mounting of auto switches for table position detection

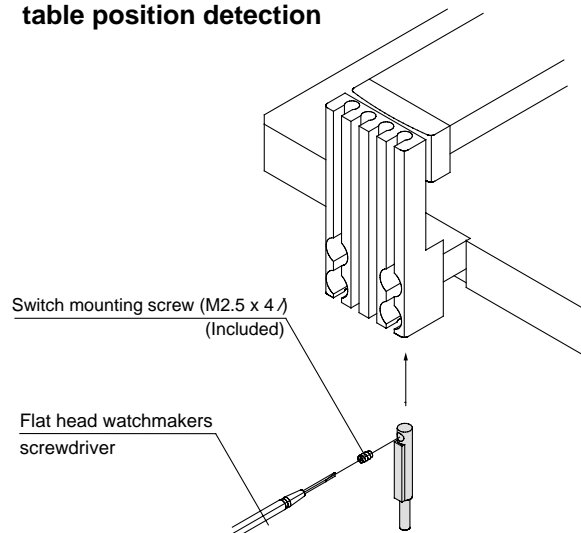

Note) When fastening the auto switch mounting screw, use a watchmakers screwdriver with a grip diameter of 5 to 6mm. The fastening torque should be 0.05 to 0.1N·m (0.51 to 1.02kgf·cm). As a rule, it should be turned about 90° past the position at which tightening can be felt.

Series MGT Auto Switches Connections and Examples

Basic Wiring

Solid state 3 wire, NPN (Power supply for switch and load are the same.)

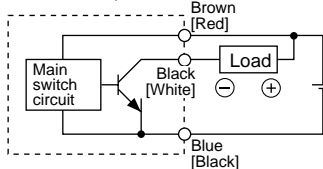

Solid state 3 wire, PNP

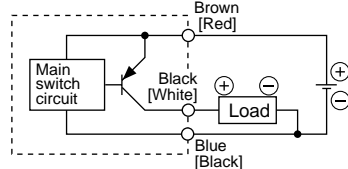

2 wire <Solid state>

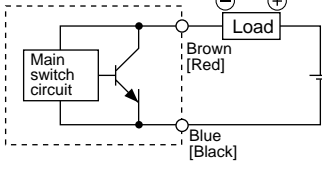

2 wire <Reed switch>

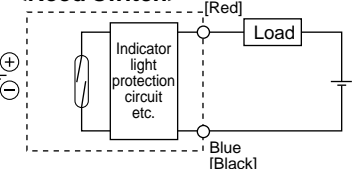

(Power supply for switch and load are separate.)

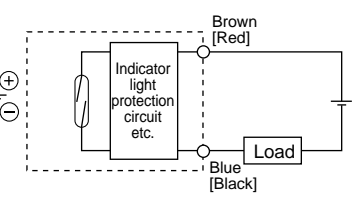
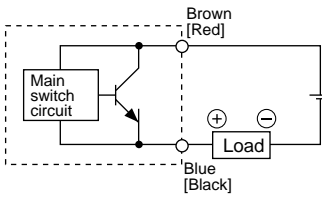
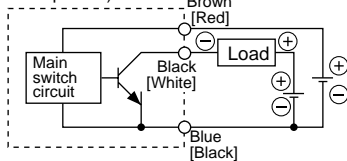

Examples of Connection to PLC (Sequence Controller)

Specification for sink input

3 wire, NPN

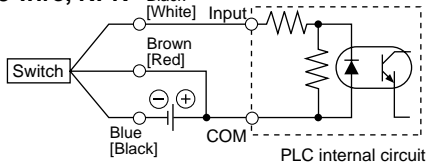

2 wire

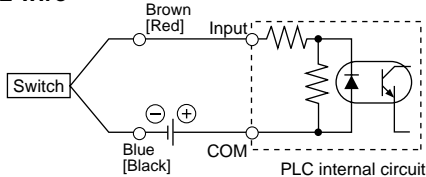

Specification for source input

3 wire, PNP

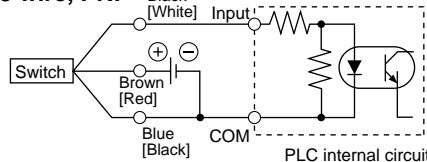

2 wire

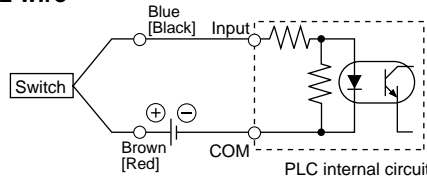

Connect according to the applicable PLC input specifications, as the connection method will vary depending on the PLC input specifications.

Connection Examples for AND (Series) and OR (Parallel)

3 wire

AND connection for NPN output (Using relays)

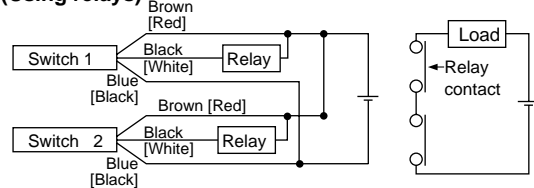

AND connection for NPN output (Performed with switches only)

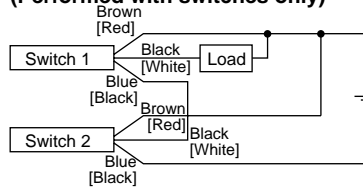

OR connection for NPN output

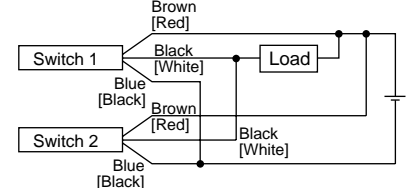

The indicator lights will light up when both switches are turned ON.

2 wire with 2 switch AND connection

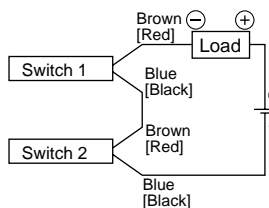

When two switches are connected in series, a load may malfunction because the load voltage will decline when in the ON state. The indicator lights will light up if both of the switches are in the ON state.

2 wire with 2 switch OR connection

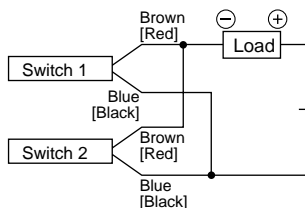

<Solid state>

When two switches are connected in parallel, malfunction may occur because the load voltage will increase when in the OFF state.

<Reed switch>

Because there is no current leakage, the load voltage will not increase when turned OFF, but due the number of switches in the ON state, the indicator lights will sometimes get dark or not light up, because of dispersion and reduction of the current flowing to the switches.

$$\begin{aligned} \text{Load voltage at ON} &= \text{Power supply voltage} - \text{Residual voltage} \times 2 \text{ pcs.} \\ &= 24\text{V} - 4\text{V} \times 2 \text{ pcs.} \\ &= 16\text{V} \end{aligned}$$

Example: Power supply is 24VDC
Voltage decline in switch is 4V

$$\begin{aligned} \text{Load voltage at OFF} &= \frac{\text{leakage current}}{\text{load impedance}} \times 2 \text{ pcs.} \times \text{load impedance} \\ &= 1\text{mA} \times 2 \text{ pcs.} \times 3\text{k}\Omega \\ &= 6\text{V} \end{aligned}$$

Example: Load impedance is 3kΩ
Leakage current from switch is 1mA