

Angular Air Gripper

Series MHC2-6/MHCA2-6

How to Order

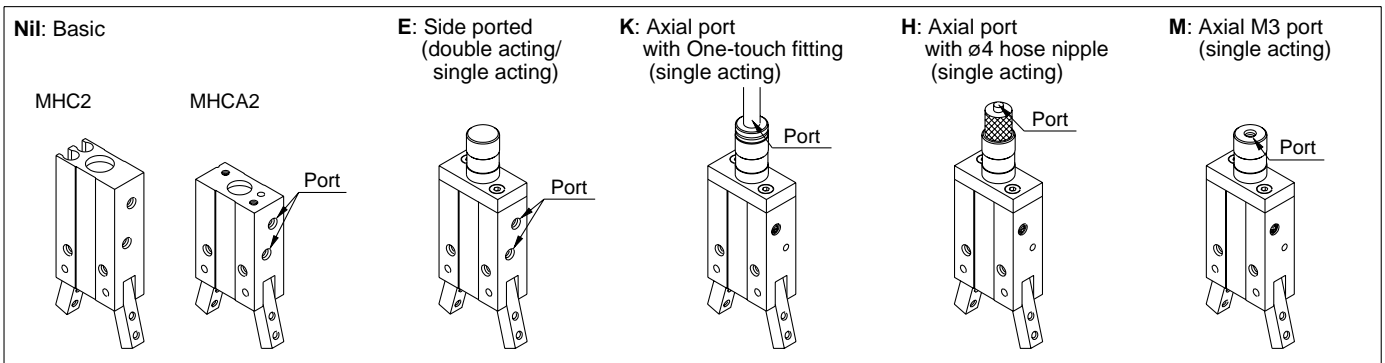
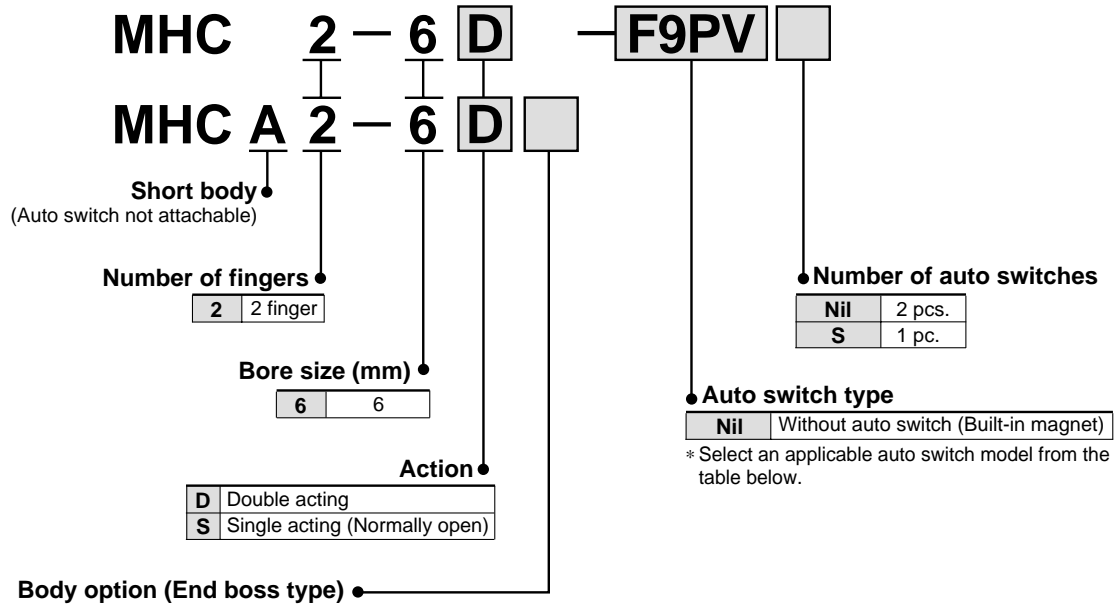

Applicable auto switches/ Refer to pages 15 through 17 for auto switch specifications.

Type	Special function	Electrical entry	Indicator light	Wiring (Output)	Load voltage		Auto switch type		Lead wire length (m)*			Note 1) Flexible lead wire (-61)	Applicable loads		
					DC	AC	Electrical entry direction	Perpendicular	In-line	0.5 (Nil)	3 (L)				5 (Z)
Solid state switch	—	Grommet	Yes	3-wire (NPN)	24V	12V	—	F9NV	F9N	●	●	○	○	—	Relay PLC
				3-wire (PNP)				F9PV	F9P	●	●	○			
				2-wire				F9BV	F9B	●	●	○			

*Lead wire length symbol: 0.5m Nil (Example) F9N
3m L (Example) F9NL
5m Z (Example) F9NZ

*Auto switches marked "O" are produced upon receipt of order.
Note 1) For the flexible wire specification, enter -61 after the part number.

(Example) When ordering with air gripper

MHC2-6D-F9NVS-61

Flexible wire

When ordering only auto switch

D-F9PL-61

Flexible wire

Angular Air Gripper *Series MHC2-6/MHCA2-6*



MHC2-6□



MHCA2-6□
Axial port
(With hose nipple)



MHCA2-6□

Specifications

Fluid		Air
Operating pressure	Double acting	0.15 to 0.6MPa
	Single acting: Normally open	0.3 to 0.6MPa
Ambient and fluid temperature		-10 to 60°C
Repeatability		±0.02mm
Maximum operating frequency		180c.p.m
Lubrication		Non-lube
Action		Double acting, Single acting (Normally open)
Auto switch (Optional) ^{Note)}		Solid state switch (3-wire, 2-wire)

Note) Refer to pages 15 through 17 for auto switch specifications.

Model

Action	Model	Cylinder bore (mm)	Holding moment ^{Note)} (Effective value) N·m	Opening/Closing angle (Both sides)	Weight ^{Note 2)} g
Double acting	MHC2-6D	6	0.038	30° to -10°	22
	MHCA2-6D	6			19
Single acting (Normally open)	MHC2-6S	6	0.024	30° to -10°	22
	MHCA2-6S	6			19

Note 1) At the pressure of 0.5MPa

Note 2) Excluding the auto switch weight.

Option

●Body option/End boss type

Symbol	Piping position	Piping port type	Applicable model	
		MHCA2-6	Double acting	Single acting
Nil	Standard	M3 x 0.5	●	●
E	Side ported	M3 x 0.5	●	●
K	Axial port	With ø4 one-touch fitting	—	●
H		With ø4 hose nipple	—	●
M		M3 x 0.5	—	●

Symbol

Double acting

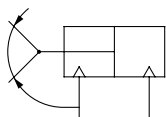

Single acting

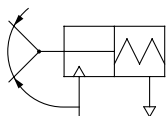

Series MHC2-6/MHCA2-6

Construction

MHC2-6

Double acting/with fingers open

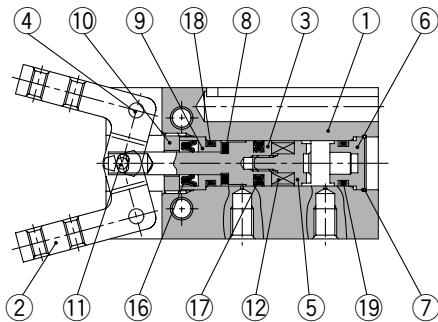

Double acting/with fingers closed Single acting

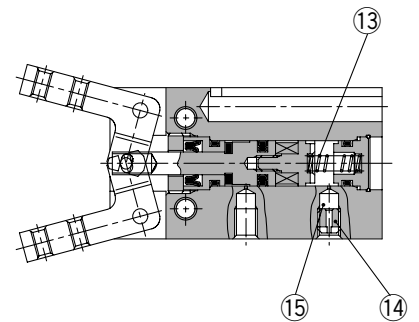
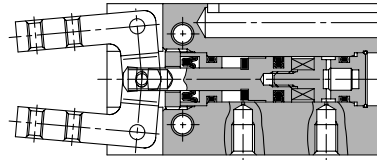

Parts list

No.	Description	Material	Note
1	Body	Aluminium alloy	Hard anodized
2	Finger	Stainless steel	Heat treatment
3	Piston	Stainless steel	
4	Lever shaft	Stainless steel	Nitriding
5	Magnet holder	Stainless steel	
6	Cap	Aluminium alloy	Hard anodized
7	Clip	Stainless steel	
8	Bumper	Urethane rubber	
9	Holder	Brass	Electroless nickel plated
10	Holder lock	Stainless steel	

Parts list

No.	Description	Material	Note
11	Needle roller	High carbon chromium bearing steel	
12	Magnet	Rare earth magnet	Nickel plated
13	NO spring	Piano wire	Zinc chromated
14	Exhaust plug	Brass	Electroless nickel plated
15	Exhaust filter	Resin	
16	Rod seal	NBR	
17	Piston seal	NBR	
18	Gasket	NBR	
19	Gasket	NBR	

Replacement parts

Description	Kit no.	Main parts	Note
Seal kit	MHC6-PS	16, 17, 18, 19	

MHCA2-6 (Short body)

Double acting/with fingers open

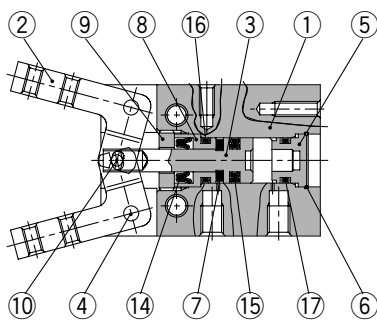

Double acting/with fingers closed Single acting

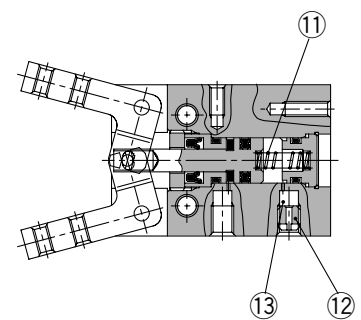
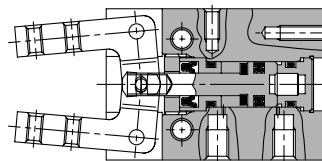

Parts list

No.	Description	Material	Note
1	Body	Aluminium alloy	Hard anodized
2	Finger	Stainless steel	Heat treatment
3	Piston	Stainless steel	
4	Lever shaft	Stainless steel	Nitriding
5	Cap	Aluminium alloy	Hard anodized
6	Clip	Stainless steel	
7	Bumper	Urethane rubber	
8	Holder	Brass	Electroless nickel plated
9	Holder lock	Stainless steel	

Parts list

No.	Description	Material	Note
10	Needle roller	High carbon chromium bearing steel	
11	NO spring	Piano wire	Zinc chromated
12	Exhaust plug	Brass	Electroless nickel plated
13	Exhaust filter	Resin	
14	Rod seal	NBR	
15	Piston seal	NBR	
16	Gasket	NBR	
17	Gasket	NBR	

Replacement parts

Description	Kit no.	Main parts	Note
Seal kit	MHCA6-PS	14, 15, 16, 17	

Series MHC2-6/MHCA2-6

Dimensions

MHCA2-6□ (Short body)

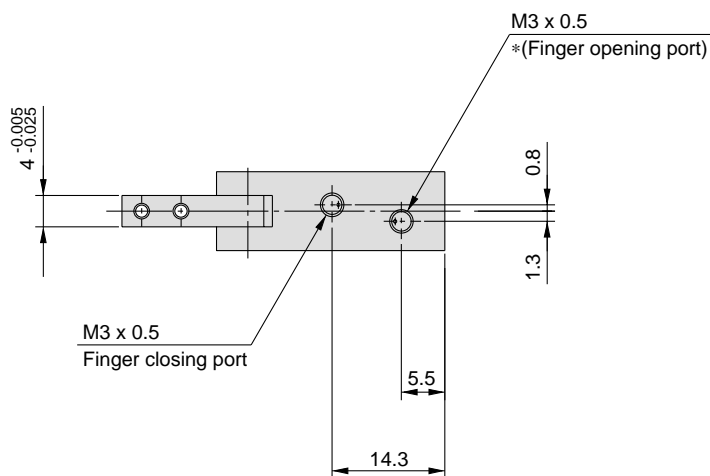
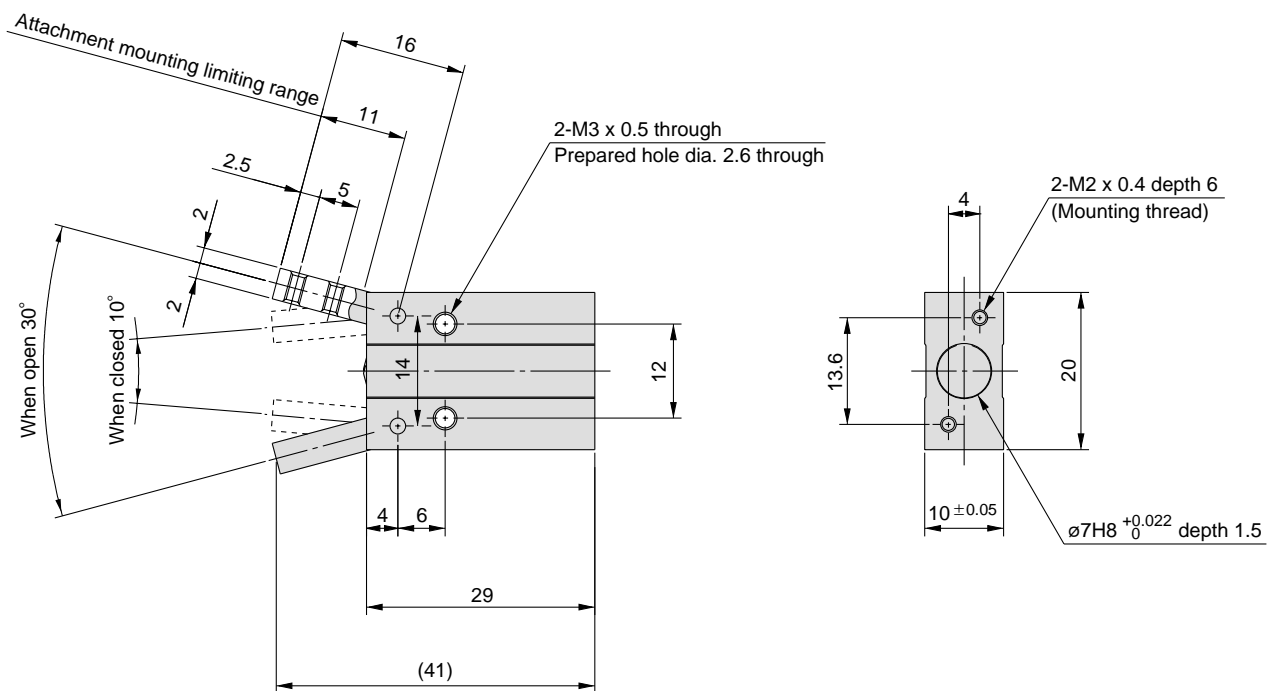
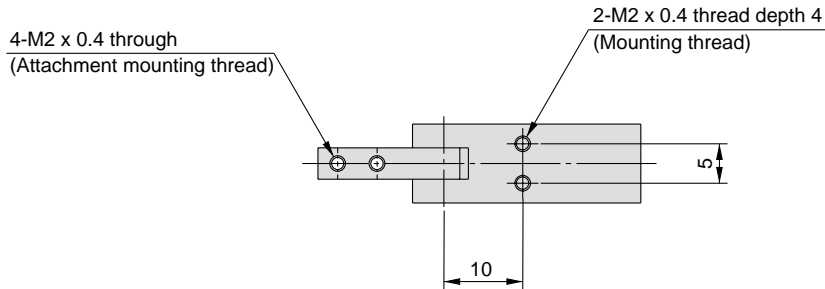

*In the case of MHCA2-6S, finger opening port is a breathing hole.

Auto Switch Hysteresis

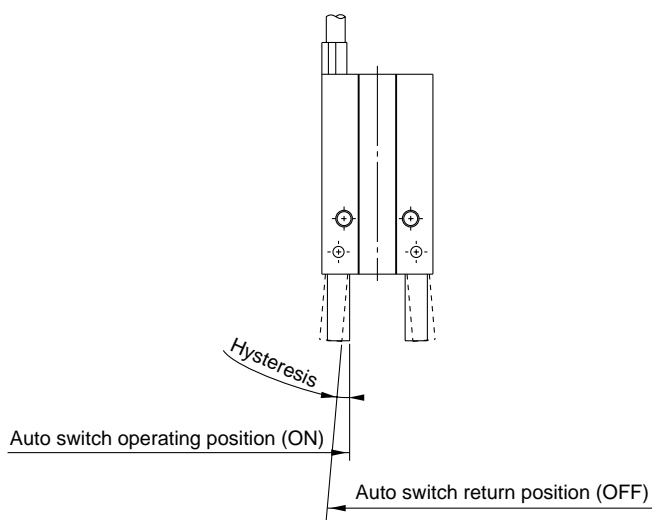

Hysteresis

Model	D-F9□(V)
MHC2-6□	4°

Auto Switch Mounting

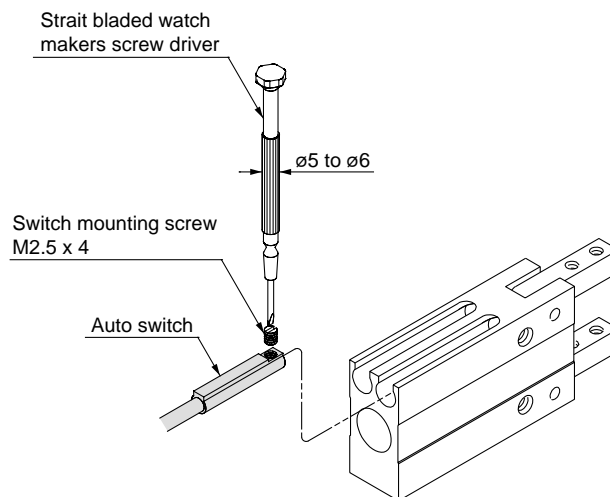

Note) Use a screwdriver with a grip diameter of 5 to 6 mm to tighten the auto switch mounting screw. The tightening torque should be about 0.05 to 0.1N·m. When you begin to feel that the screw is being tightened, turn it further by 90°.

Auto Switch Protrusion from the Body End Surface

- The amount of auto switch protrusion from the body end surface is shown in the table below.
- Use this as a standard when mounting, etc.

Model	Lead wire type	Illustration	In-line entry	Perpendicular entry
			D-F9	D-F9□V
MHC2-6□	Open		6.5	4.5
	Close		9	7

Series MHCA2

Body Option: End Boss Type

Applicable Model

Symbol	Piping position	Piping port type	Applicable model	
			Double acting	Single acting
E	Side ported	M3 x 0.5	●	●
H	Axial port	With ø4 hose nipple	—	●
K		With ø4 one-touch fitting	—	●
M		M3 x 0.5	—	●

Side Ported [E]

MHCA2-6□E

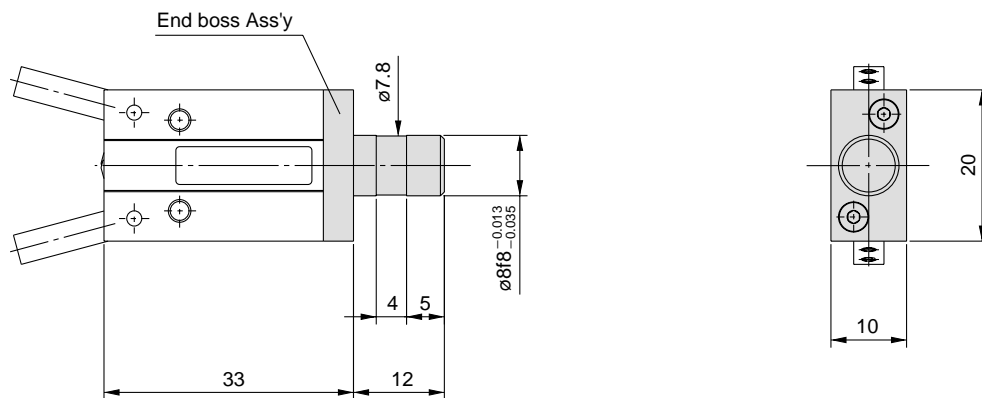

*The specifications and dimensions not given above are identical with those of the standard type.

Axial Port (with hose nipple) [H]

MHCA2-6SH

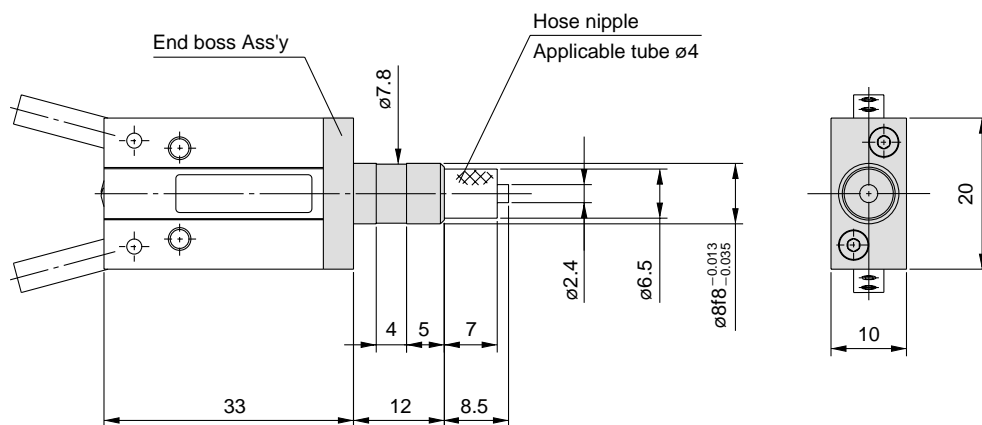

*The specifications and dimensions not given above are identical with those of the standard type.

Applicable tube

Description/Model	Nylon tube	Soft nylon tube	Polyurethane tube	Polyurethane coil tube
Specifications	T0425	TS0425	TU0425	TCU0425B-1
Outside diameter mm	4	4	4	4
Max. operating pressure MPa	1.0	0.8	0.5	0.5
Min. bending radius mm	13	12	10	—
Operating temperature °C	-20 to 60	-20 to 60	-20 to 60	-20 to 60
Material	Nylon 12	Nylon 12	Polyurethane	Polyurethane

For one-touch fittings and tubing, refer to SMC's "Best Pneumatics vol. 4" catalog.

Axial Port (with One touch fitting) [K]

MHCA2-6SK

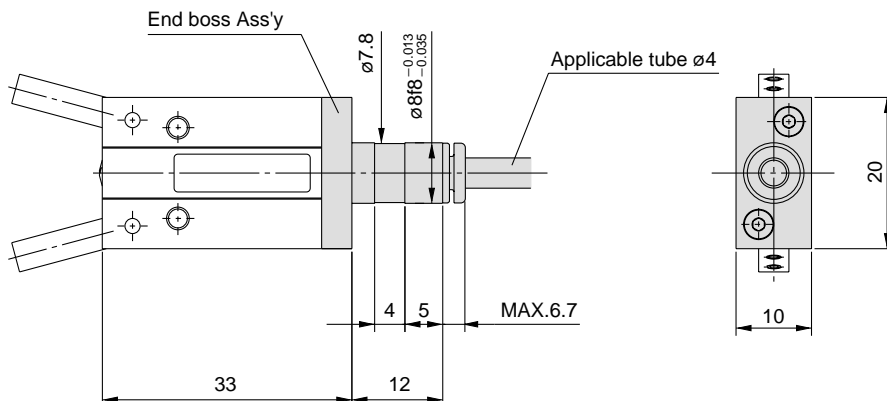

*The specifications and dimensions not given above are identical with those of the standard type.

Applicable tube

Description, model	Nylon tube	Soft nylon tube	Polyurethane tube	Polyurethane coil tube
	T0425	TS0425	TU0425	TCU0425B-1
Outside diameter mm	4	4	4	4
Max. operating pressure MPa	1.0	0.8	0.5	0.5
Min. bending radius mm	13	12	10	—
Operating temperature °C	-20 to 60	-20 to 60	-20 to 60	-20 to 60
Material	Nylon12	Nylon12	Poly urethane	Poly urethane

For one-touch fittings and tubing, refer to SMC's "Best Pneumatics vol. 4" catalog.

Axial Port (with M3 port) [M]

MHCA2-6SM

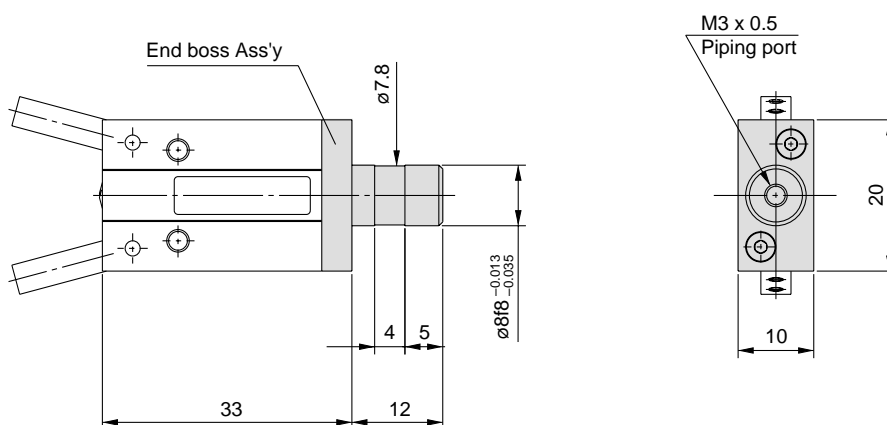

*The specifications and dimensions not given above are identical with those of the standard type.

Weights

Model	End boss type (symbol)			
	E	H	K	M
MHCA2-6□□	23	23	23	23

Unit: g

Series MHC2 Auto Switch Common Specifications

Auto Switch Common Specifications

Type	Solid state switch
Operating time	1ms or less
Shock resistance	1000m/s ²
Insulation resistance	50MΩ or more at 500VDC (Between lead wire and case)
Withstand voltage	1000VAC for 1min. (Between lead wire and case)
Ambient temperature	-10 to 60°C
Enclosure	IEC529 standard IP67, JISC0920 watertight construction

Lead Wire Length

Lead wire length indication

(Example)

D-F9P **L**

●Lead wire length

Nil	0.5m
L	3m
Z	5m

Note 1) Lead wire length Z: 5m applicable auto switch
Solid state switch: All models are produced upon receipt of order
(as standard).

Note 2) For the flexible wire specification, enter -61 after the part number.

(Example) D-F9PL-**61**

●Flexible wire specifications

Lead Wire Color Changes

The lead wire colors of SMC auto switches have been changed as shown below to satisfy IEC947-5-2 standards for production beginning September, 1996 and thereafter.

Take special care regarding wire polarity during the time that old colors still coexist with the new colors.

2-wire

	Old	New
Output (+)	Red	Brown
Output (-)	Black	Blue

3-wire

	Old	New
Power supply	Red	Brown
GND	Black	Blue
Output	White	Black

Series MHC2 Auto Switch Connections and Examples

Basic Wiring

Solid state 3-wire, NPN

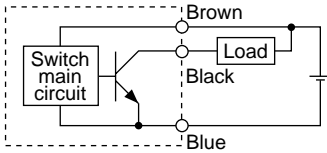

When power source for switch and load is not common.

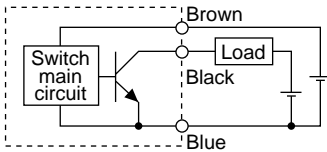

Solid state 3-wire, PNP

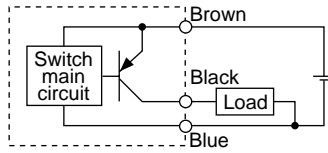

2-wire system

<Solid state>

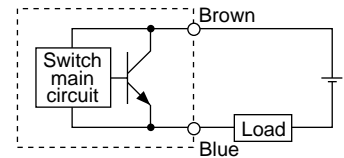
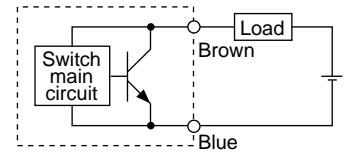

Examples of Connection to PLC (Sequence Controller)

Sink input specification 3-wire, NPN

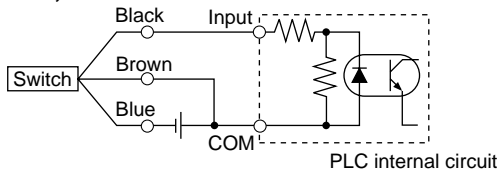

Source input specification 3-wire, PNP

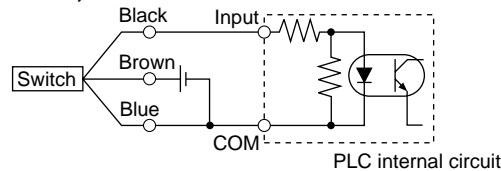

Connect according to the input specification of the sequence controller, because the connection method varies with the input specification of the sequence controller.

2-wire

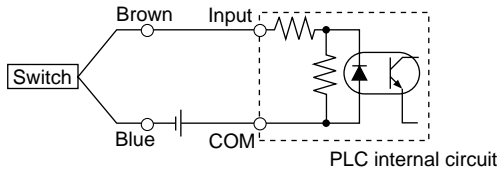

2-wire

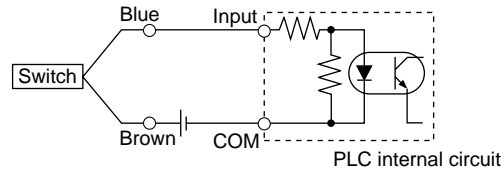

Connection Examples for AND (Series) and OR (Parallel)

3-wire

AND connection for NPN output (Using relays)

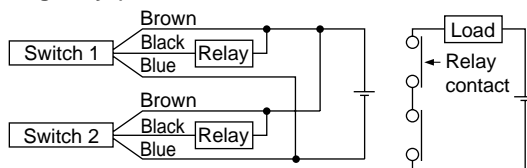

AND connection for NPN output (Performed with switches only)

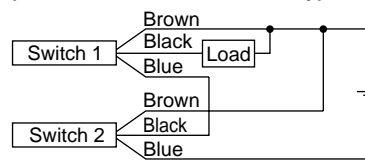

OR connection for NPN output

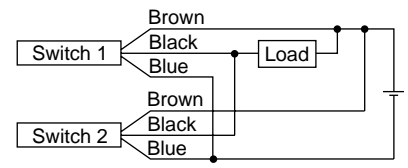

The indicator lights will light up when both switches are turned ON.

2-wire with 2 switch AND connection

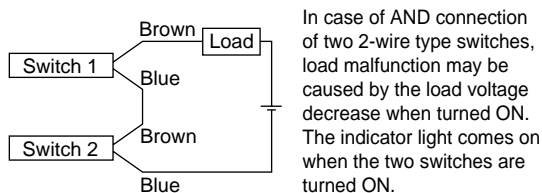

In case of AND connection of two 2-wire type switches, load malfunction may be caused by the load voltage decrease when turned ON. The indicator light comes on when the two switches are turned ON.

$$\begin{aligned} \text{Load voltage when turned ON} &= \text{Power supply voltage} - \text{Residual voltage} \times 2 \text{ pcs.} \\ &= 24\text{V} - 4\text{V} \times 2 \text{ pcs.} \\ &= 16\text{V} \end{aligned}$$

(Example) Power supply: 24VDC
Internal voltage drop: 4V

2-wire with 2 switch OR connection

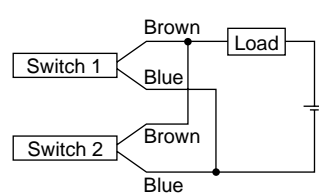

<Solid state>

In case of OR connection of two 2-wire type switches, load malfunction may be caused by the load voltage increase when turned OFF.

$$\begin{aligned} \text{Load voltage when turned OFF} &= \text{Leakage voltage} \times 2 \text{ pcs.} \times \text{Load impedance} \\ &= 1\text{mA} \times 2 \text{ pcs.} \times 3\text{k}\Omega \\ &= 6\text{V} \end{aligned}$$

(Example) Load impedance: 3kΩ
Current leakage: 1mA

Solid State Switch/Direct Mounting D-F9N(V), D-F9P(V), D-F9B(V)

Grommet



Auto Switch Specifications

D-F9□, D-F9□V (With indicator light)						
Auto switch symbol	D-F9N	D-F9NV	D-F9P	D-F9PV	D-F9B	D-F9BV
Electrical entry	In-line	Perpendicular	In-line	Perpendicular	In-line	Perpendicular
Wiring method	3-wire				2-wire	
Output method	NPN		PNP		—	
Applicable load	IC circuit, Relay, PLC				24VDC Relay, PLC	
Power supply	5, 12, 24VDC (4.5 to 28V)				—	
Current consumption	10mA or less				—	
Load voltage	28VDC or less		—		24VDC (10 to 28VDC)	
Load current	40mA or less		80mA or less		5 to 40mA	
Internal voltage drop	1.5V or less (0.8V or less at 10mA load current)		0.8V or less		4V or less	
Leakage current	100μA or less at 24VDC				0.8mA or less	
Indicator light	Red LED lights when ON					

O Lead wire — Heavy duty oil resistant, $\phi 2.7$, 3 cores (Brown, Black, Blue), 0.15mm², 2 cores (Brown, Blue), 0.18mm², 0.5m

Note 1) Refer to page 15 for solid state switch common specifications.

Note 2) Refer to page 15 for lead wire length.

Auto Switch Internal Circuits

D-F9N, F9NV

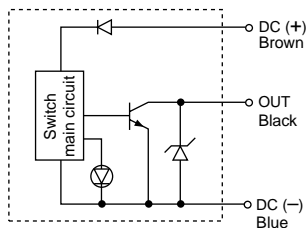

D-F9P, F9PV

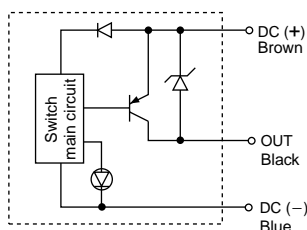

D-F9B, F9BV

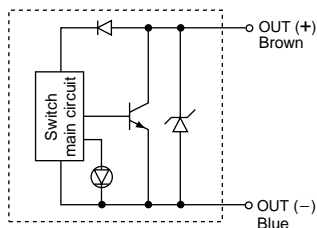

Auto Switch Weights

Unit: g

Auto switch part no.		D-F9N(V)	D-F9P(V)	D-F9B(V)
Lead wire length (m)	0.5	7	7	6
	3	37	37	31
	5	61	61	51

Auto Switch Dimensions

D-F9□

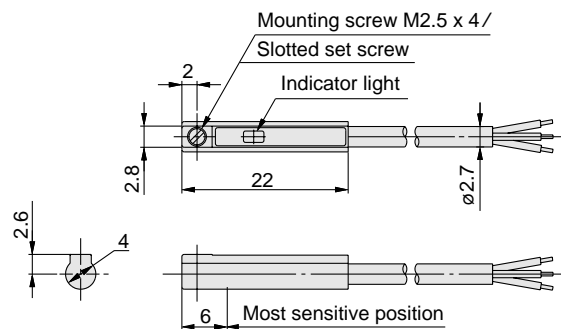

D-F9□V

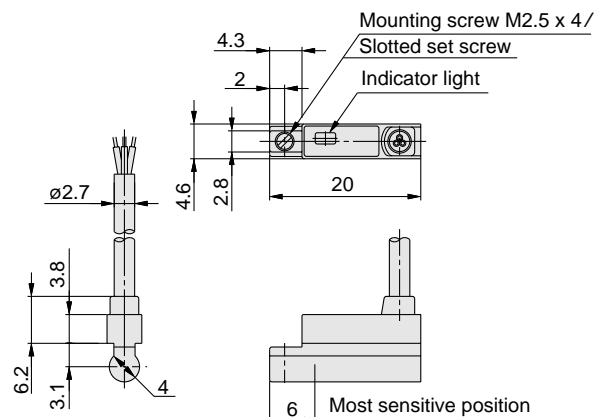





Series MHC2/MHCA2/MHCM2 Safety Instructions

These safety instructions are intended to prevent a hazardous situation and/or equipment damage. These instructions indicate the level of potential hazard by a label of "**Caution**", "**Warning**" or "**Danger**". To ensure safety, be sure to observe ISO 4414 Note 1), JIS B 8370 Note 2) and other safety practices.

 **Caution** : Operator error could result in injury or equipment damage.

 **Warning** : Operator error could result in serious injury or loss of life.

 **Danger** : In extreme conditions, there is a possible result of serious injury or loss of life.

Note 1) ISO 4414 : Pneumatic fluid power – Recommendations for the application of equipment to transmission and control systems.

Note 2) JIS B 8370 : General Rules for Pneumatic Equipment

Warning

1. The compatibility of pneumatic equipment is the responsibility of the person who designs the pneumatic system or decides its specifications.

Since the products specified here are used in various operating conditions, their compatibility for the specific pneumatic system must be based on specifications or after analysis and/or tests to meet your specific requirements. The expected performance and safety assurance will be the responsibility of the person who has determined the compatibility of the system. This person should continuously review the suitability of all items specified. Referring to the latest catalog information with a view to giving due consideration to any possibility of equipment failure when configuring a system.

2. Only trained personnel should operate pneumatically operated machinery and equipment.

Compressed air can be dangerous if handled incorrectly. Assembly, handling or repair of pneumatic systems should be performed by trained and experienced operators.

3. Do not service machinery/equipment or attempt to remove components until safety is confirmed.

1. Inspection and maintenance of machinery/equipment should only be performed after confirmation of safe locked-out control positions.
2. When equipment is to be removed, confirm the safety process as mentioned above. Cut the supply pressure for this equipment and exhaust all residual compressed air in the system.
3. Before machinery/equipment is restarted, take measures to prevent shooting-out of cylinder piston rod, etc. (Bleed air into the system gradually to create back pressure.)

4. Contact SMC if the product is to be used in any of the following conditions:

1. Conditions and environments beyond the given specifications, or if product is used outdoors.
2. Installation on equipment in conjunction with atomic energy, railway, air navigation, vehicles, medical equipment, food and beverages, recreation equipment, emergency stop circuits, press applications, or safety equipment.
3. An application which has the possibility of having negative effects on people, property, or animals, requiring special safety analysis.



Series MHC2/MHCA2/MHCM2 Air Gripper Precautions 1

Be sure to read before handling.

Precautions on design

Warning

1. A protective cover is recommended to minimize the risk of personal injury due to accidental contact with moving parts of the gripper.
2. If circuit pressure drops due to a power failure or trouble with the air supply, etc., there is a danger of work pieces dropping because of reduced gripping force. Measures should be taken to protect against unexpected drop of work due to loss of air pressure.

Selection

Warning

1. Keep the holding point within the specified range of the holding distance.

When the holding point distance becomes large, the finger attachment applies an excessively large load to the cross roller section, causing excessive play of the fingers and possibly leading to premature failure. Refer to the graph of the specified range of the holding distance for each series.

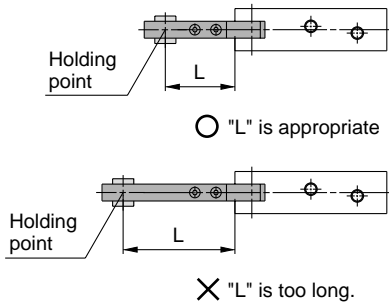

2. Attachments should be designed as light and short as possible.

1. Long and heavy attachment increases the inertial force to open and close the fingers. It may cause unsteady movement of fingers and have an adverse effect on life.
2. Even if holding point remains within the limited range, make the attachment as light and short as possible.

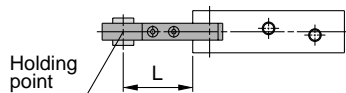

Selection

Warning

3. Select the large size gripper or use two or more grippers for one piece at once for handling long and large work.
3. Provide run off space in the attachment when using for the small or thin work.

If the run off space is not provided, with the finger part, holding condition becomes unsteady and the holding point may slide from the best position.

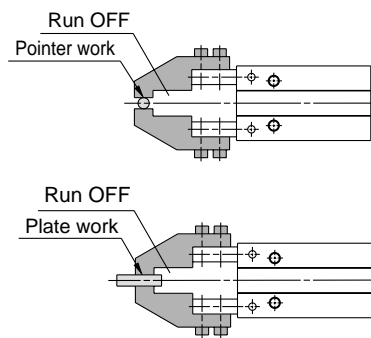

4. Select the model whose holding force is sufficient against work weight.

Incorrect selection may lead to release of work etc. Refer to "Effective holding force" and information to select the model by weight of work.

5. Do not use in applications where excessive external force or impact force may be applied to gripper.

It may cause malfunction. Consult SMC with regard to any other applications.

6. Select the model taking the width of fingers between opening and closing points into consideration.

<In case of short width>

1. The holding condition becomes unsteady due to the unstable opening/closing width or the changeable work diameter.
2. When using the auto switch, the detection is insufficient. Refer to "Auto Switch Hysteresis" and set the stroke including the hysteresis length for reliable switch function. When using water tight 2-color display auto switch, operation stroke may be limited due to light color setting at detection point. Refer to hysteresis of auto switch.

Selection

Warning

7. Consult with SMC in case of a single acting type, gripping with spring force only.

This can cause unstable gripping in some cases or return malfunction, due to faulty operation, etc.

Mounting

Warning

1. Do not drop nor dent the gripper when mounting.

Slight deformation can cause unaccuracy or malfunction.

2. Tighten the screw within the specified torque range to mount the attachment.

The tightening with large torque than specified range may cause malfunction, while the tightening with smaller torque may allow movement of holding position and dropping of work.

How to mount the attachment on fingers

Mount the attachment to the mounting female thread of the finger with a bolt etc. applying the following tightening torque.

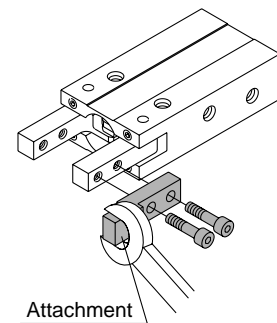

Model	Bolt used	Maximum tightening torque N·m
MHC□2-6	M2 x 0.4	0.15
MHCM2-7S	M2 x 0.4	0.15



Series MHC2/MHCA2/MHCM2 Air Gripper Precautions 2

Be sure to read before handling.

Mounting

⚠ Caution

3. Adjust the holding point so that excessive force will not be applied on fingers when inserting the work.

Particularly when performing a trial run, operate the equipment manually or with low cylinder pressure and speed while confirming that there is no impact or other unsafe conditions.

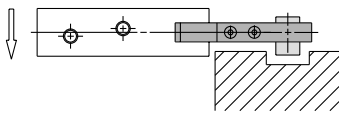

○ Holding point is adjusted

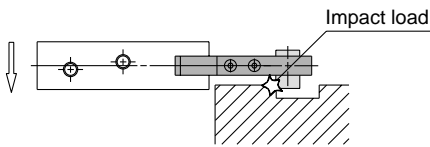

✕ Holding point is not adjusted

4. If the finger opens and closes at an excessive speed, the work piece may not be gripped precisely. Also, rattles or damage may be caused by inertia of the fingers or attachments. Install a speed controller to prevent shocks. Use a meter-in type speed controller.

Air gripper mounted type: AS1211F-M3

5. High frequency operation or long piping may cause condensation inside the air gripper or piping. For this reason, use a quick exhaust valve.

Air gripper mounted type: ASV1□0F-M3

Inline type: AQ240F-04

Piping

⚠ Caution

1. Preparation before piping
Thoroughly flush the fittings to prevent dust or chips from entering the gripper.
2. Wrapping of pipe tape
When piping and fittings are installed, care should be taken to prevent contamination (Chips from piping and seal materials).
Also, when pipe tape is used, leave 1.5 to 2 thread ridges exposed at the end.

Environment

⚠ Warning

1. Do not use in environment of corrosive gases, sea water, water, hot water, nor vapor or in environment gives bad influence specially.
2. Do not use in direct sun light.
3. Do not subject to excessive vibration.
4. Do not use close to flame.
5. Use a cover when gripper must be used in an environment where dust or cutting oil will come in contact with gripper.
6. Consult SMC for the use in any other special environment.

Lubrication

⚠ Caution

1. Non-lube type is lubricated already. Therefore, it is not necessary to lubricate before using.
When lubricating the gripper, use the turbine oil class1 (ISO VG32) and refuel continually.
When lubrication has been started, it must be continued throughout the life of the gripper or malfunction may result.

Maintenance

⚠ Warning

1. Do not enter the transfer line nor put the object.
It may cause unexpected accidents.
2. Do not enter your hands between finger and attachment.
It may cause unexpected accidents.
3. Confirm that no work is held by fingers before releasing the compressed air to remove the gripper from the line.
Dropping of work can be dangerous.



Series MHC2/MHCA2/MHCM2 Air Gripper Precautions 3

Be sure to read before handling.

Mounting

Warning

3. Tighten the screw within the specified torque range to mount the attachment.

The tightening with large torque than specified range may cause malfunction, while the tightening with smaller torque may allow movement of holding position and dropping of work.

Mounting of air gripper

Axial mounting (Body tapped)

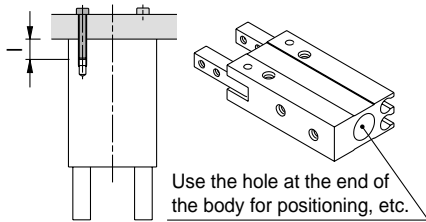

Model	Bolt used	Max. tightening torque N·m	Max. screw-in depth /mm
MHCA2-6	M2 x 0.4	0.15	6
MHCM2-7S	M2 x 0.4	0.15	4

Note) Axial mounting type is not available with MHC2-6.

Model	Bore mm	Hole depth mm
MHCA2-6	$\varnothing 7H8 \begin{smallmatrix} +0.022 \\ 0 \end{smallmatrix}$	1.5

Longitudinally mounting type (Body tap)

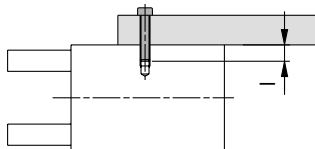

Model	Bolt used	Max. tightening torque N·m	Max. screw-in depth /mm
MHCA2-6	M2 x 0.4	0.15	4

Note) Perpendicular mounting type is not available with MHC2-6 and MHCM2-7S.

Side mounting (Body tapped, Body through hole)

●Using the body tapped

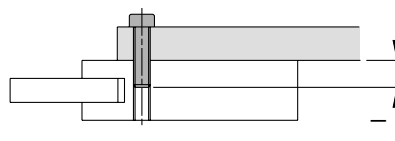

Model	Bolt used	Max. tightening torque N·m	Max. screw-in depth /mm
MHC2-6	M3 x 0.5	0.88	10
MHCA2-6	M3 x 0.5	0.88	10
MHCM2-7S	M2 x 0.4	0.15	10

●Using the body through hole

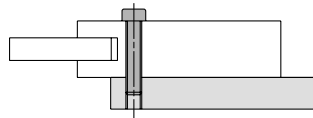

Model	Bolt used	Max. tightening torque N·m
MHC2-6	M2.5 x 0.45	0.49
MHCA2-6	M2.5 x 0.45	0.49

Note) Body through hole type is not available with MHCM2-7S.

Caution

1. Avoid the excessive force on fingers when mounting the attachment.

Any change of fingers may cause the malfunction and deteriorate the accuracy.

2. Avoid the external force to fingers.

Fingers may be damaged by continual lateral or the impact load. Provide clearance to prevent the work or the attachment from striking against any object at the stroke end.

1. Finger opening and closing stroke

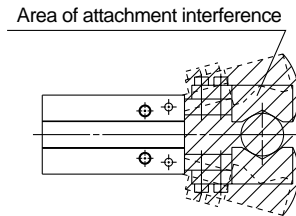

2. Stroke end when gripper is moving

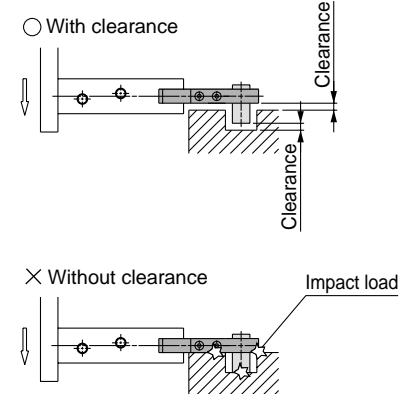

3. When turning over

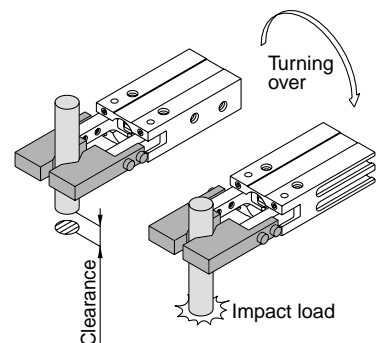



Series MHC2 Auto Switch Precautions 1

Be sure to read before handling.

Design and Selection

Warning

1. Confirm the specifications.

Read the specifications carefully and use this product appropriately. The product may be damaged or malfunction if it is used outside the range of specifications for load current, voltage, temperature or impact.

2. Take precautions when multiple air grippers are used close together.

When multiple auto switch air grippers are used in close proximity, magnetic field interference may cause the switches to malfunction. Maintain a minimum air gripper separation of 40 mm. (When the allowable separation is indicated for each air gripper series, use the specified value.)

3. Pay attention to the length of time that a switch is ON at an intermediate stroke position.

When an auto switch is placed at an intermediate position of the stroke and a load is driven at the time the piston passes, although the auto switch will operate, the operating time will be shortened and the load may not operate properly if the speed is too great. The maximum detectable piston speed is:

$$V(\text{mm/s}) = \frac{\text{Auto switch operating range (mm)}}{\text{Load operating time (ms)}} \times 1000$$

4. Keep wiring as short as possible.

<Solid state switch>

Although wire length should not affect switch function, use a wire of 100m or shorter.

5. Take precautions for the internal voltage drop of the switch.

<Solid state switch>

Generally, the internal voltage drop will be greater with a 2-wire solid state auto switch than with a reed switch.

- Take note that there will be a large voltage drop if auto switches are connected in series as shown below. (Refer to internal voltage drop in the auto switch specifications.)

[The voltage drop will be "n" times larger when "n" auto switches are connected.]

Even though an auto switch operates normally, the load may not operate.



- In the same way, when operating below the specified voltage, although an auto switch may operate normally, the load may not operate. Therefore, the formula below should be satisfied after confirming the minimum operating voltage of the load.

$$\text{Supply voltage} - \text{Internal voltage drop of switch} > \text{Minimum operating voltage of load}$$

Also, note that a 12VDC relay is not applicable.

6. Pay attention to leakage current.

<Solid state switch>

With a 2-wire solid state auto switch, current (leakage current) flows to the load to operate the internal circuit even when in the OFF state.

$$\text{Operating current of load (OFF condition)} > \text{Leakage current}$$

If the criteria given by the above formula are not met, it will not reset correctly (stays ON). Use a 3-wire switch if this specification will not be satisfied.

Moreover, leakage current flow to the load will be "n" times larger when "n" auto switches are connected in parallel.

7. Do not use a load that generates surge voltage.

<Solid state switch>

Although a zener diode for surge protection is connected at the output side of a solid state auto switch, damage may still occur if the surge is applied repeatedly. When a load, such as a relay or solenoid, which generates surge is directly driven, use a type of switch having a built-in surge absorbing element.

8. Cautions for use in an interlock circuit.

When an auto switch is used for an interlock signal requiring high reliability, devise a double interlock system to avoid trouble by providing a mechanical protection function, or by also using another switch (sensor) together with the auto switch. Also perform periodic maintenance and confirm proper operation.

9. Secure sufficient clearance for maintenance activities.

When designing an application, be sure to allow sufficient clearance for maintenance and inspections.

Mounting and Adjustment

Warning

1. Do not drop or bump.

Do not drop, bump or apply excessive impacts (1000m/s² or more for solid state switches) while handling.

Although the body of the switch may not be damaged, the inside of the switch could be damaged and cause a malfunction.

2. Do not carry a cylinder by the auto switch lead wires.

Never carry a cylinder by its lead wires. This may not only cause broken lead wires but it may cause internal elements of the switch to be damaged by the stress.

3. Mount switches using the proper fastening torque.

When a switch is tightened beyond the range of fastening torque, the mounting screws, mounting bracket or switch may be damaged. On the other hand, tightening below the range of fastening torque may allow the switch to slip out of position. (Refer to page 6 regarding switch mounting, movement and fastening torque, etc.)

Wiring

Warning

1. Avoid repeatedly bending or stretching lead wires.

Broken wires will result from applying repeated bending stress or stretching force to the lead wires.

2. Be sure to connect the load before power is applied.

<2-wire type>

If the power is turned ON when an auto switch is not connected to a load, the switch will be instantly damaged because of excess current.

3. Confirm proper insulation of wiring.

Be certain that there is no faulty wiring insulation (contact with other circuits, ground fault, improper insulation between terminals, etc.). Damage may occur due to excess current flow into a switch.



Series MHC2 Auto Switch Precautions 2

Be sure to read before handling.

Wiring

Warning

4. Do not run wiring near power lines or high voltage lines.

Wire separately from power lines or high voltage lines, avoiding parallel wiring or wiring in the same conduit with these lines. Control circuits containing auto switches, may malfunction due to noise from these other lines.

* Lead wire color changes

Lead wire colors of SMC switches have been changed in order to meet NECA Standard 0402 for production beginning September, 1996 and thereafter.

Special care should be taken regarding wire polarity during the time that the old colors still coexist with the new colors.

2-wire

	Old	New
Output (+)	Red	Brown
Output (-)	Black	Blue

3-wire

	Old	New
Power supply (+)	Red	Brown
Power supply GND	Black	Blue
Output	White	Black

5. Solid state with latch type diagnostic output.

<Solid state switch>

Model D-F9□(V) and all models of PNP output type switches do not have built-in short circuit prevention circuits. If loads are short circuited, the switches will be instantly damaged.

Take special care to avoid reverse wiring with the power supply line (brown) and the output line (black) on 3-wire type switches.

6. Avoid incorrect wiring.

<Solid state switch>

- 1) If connectors are reversed on a 2-wire type switch, the switch will not be damaged if protected by a protection circuit, but the switch will always stay in an ON state. However, it is still necessary to avoid reversed connections, since the switch could be damaged by a load short circuit in this condition.
- 2) If connections are reversed (power supply line + and power supply line -) on a 3 wire type switch, the switch will be protected by a protection circuit. However, if the power supply line (+) is connected to the blue wire and the power supply line (-) is connected to the black wire, the switch will be damaged.

Operating Environment

Warning

1. Never use in an atmosphere of explosive gases.

The structure of auto switches is not intended to prevent explosion. Never use in an atmosphere with an explosive gas since this may cause a serious explosion.

2. Do not use in an area where magnetic field is generated.

Auto switches will malfunction or magnets inside air grippers will become demagnetized.

3. Do not use in an environment where auto switches will be continually exposed to water.

Although switches, except for a few models, conform to the IEC standard IP67 structure (JIS C 0920: watertight construction), do not use switches in applications where they are continually exposed to water splash or spray. Poor insulation or swelling of the potting resin inside switches may cause malfunction.

4. Do not use in an environment with oil or chemicals.

Consult SMC if auto switches will be used in an environment with coolant, cleaning solvent, various oils or chemicals. If auto switches are used under these conditions for even a short time, they may be adversely affected by improper insulation, malfunction due to swelling of the potting resin, or hardening of the lead wires.

5. Do not use in an environment with temperature cycles.

Consult SMC if switches are used where there are temperature cycles other than normal temperature changes, as they may be adversely affected internally.

6. Do not use in locations where surge is generated.

<Solid state switch>

When there are units (solenoid type lifter, high frequency induction furnace, motor, etc.) which generate a large amount of surge in the area around air grippers with solid state auto switches, this may cause deterioration or damage to the switches. Avoid sources of surge generation and disorganized lines.

Operating Environment

Warning

7. Avoid accumulation of iron powder or close contact with magnetic substances.

When a large amount of ferrous powder such as machining chips or spatter is accumulated, or a magnetic substance (something attracted by a magnet) is brought into close proximity with an auto switch air gripper, it may cause the auto switch to malfunction due to a loss of the magnetic force inside the air gripper.

Maintenance

Warning

1. Perform the following maintenance periodically in order to prevent possible danger due to unexpected auto switch malfunction.

- 1) Secure and tighten switch mounting screws.
If screws become loose or the mounting position is dislocated, retighten them after readjusting the mounting position.
- 2) Confirm that there is no damage to lead wires.
To prevent faulty insulation, replace switches or repair lead wires, etc., if damage is discovered.

Other

Warning

1. Consult SMC concerning water resistance, elasticity of lead wires, and usage at welding sites, etc.