

Mechanically Jointed Hy-rodless Cylinder with Brake

Series ML1C

ø25, ø32, ø40

Brake mechanism has been compactly integrated into the slide table which enables intermediate stops of the rodless cylinder.

Large holding brake force

Force from 4 brake springs hold slide tightly.

- Holding force ø25 — 320 N
- ø32 — 500 N
- ø40 — 800 N

Brake construction is designed not to allow loads on guide.

Spring force works directly on the brake-shoe and the brake plate is caught between brake shoes from top and bottom so that the slide table can stop without compromising guide performance. The brake shoe yields long service life due to special friction resistant material.

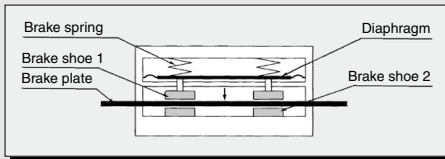

Stroke adjustment unit combines a shock absorber and stopper bolt.

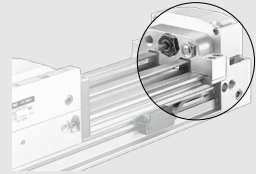

Stop is possible at the arbitrary position.

Locking in both directions is possible.

Locking in either side of cylinder stroke is possible, too.



External air piping for brake release not required.

Brake releasing air flows from head cover to slide table through air tube in cylinder body. There is no restriction on piping requirements because piping to the outside of the slide table is not necessary.

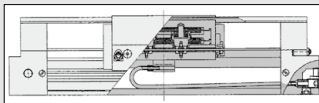

Cam follower guide type

Cam follower is adopted for the guide section. Trafficability is excellent in moment resistance.

CLJ2
CLM2
CLG1
CL1
MLGC
CNG
MNB
CNA2
CNS
CLS
CLQ
RLQ
MLU
MLGP
ML1C

D-□
-X□

Prior to Use

Maximum Allowable Moment/Maximum Load Mass

Model	Allowable moment (N·m)			Maximum load mass (kg)			
	M1	M2	M3	W1	W2	W3	W4
ML1C25	14.7	4.90	4.90	20	12	3	10
ML1C32	29.4	9.80	9.80	32	19	5	16
ML1C40	58.8	19.6	19.6	50	30	8	25

Maximum Allowable Moment

Select the moment within the limits shown in the graphs below. Note that the maximum payload value in some cases may exceed maximum allowable payload despite being within the limit shown in the graph; therefore, payload on the operating conditions should be checked.

Caution on Design

Allowable moment and Load Mass Maximum

Allowable moment and Maximum load mass varies depending on mounting orientation, piston speed, etc. Therefore use the cylinder within the range shown in the graph corresponding to operating conditions.

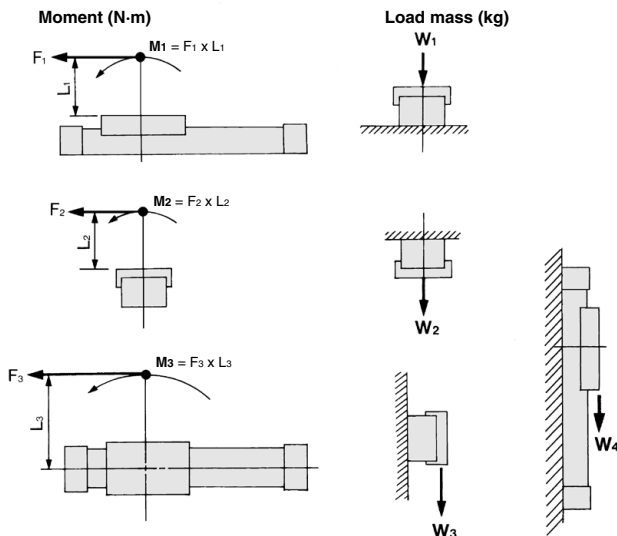

ML1C/M1

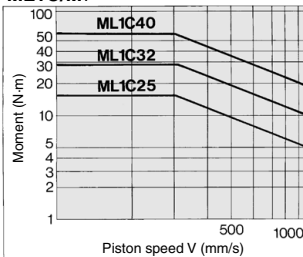

ML1C/M2, M3

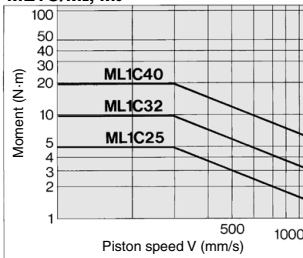

(How to calculate the load ratio)

A. Consider (1) max. load mass, (2) static moment, (3) dynamic moment (when stopper collides) when calculating the max. allowable moment and load mass.

• Evaluate (1) and (2) as νa (average speed), and (3) as ν (collision speed $\nu = 1.4 \nu a$). Calculate (1) (W_{max}) from the graph of max. payload (W_1, W_2, W_3) and calculate (2) and (3) (M_{max}) from the maximum allowable moment graph (M_1, M_2, M_3).

$$\sum \alpha = \frac{\text{Load mass [m]}}{\text{Maximum load mass [m-max]}} + \frac{\text{Static moment [M]^{Note 1}}}{\text{Static allowable moment [Mmax]}} + \frac{\text{Dynamic moment [ME]^{Note 2}}}{\text{Dynamic allowable moment [MEmax]}} \leq 1$$

Note 1) Moment generated by load, etc. when the cylinder stops.

Note 2) Moment generated by load equivalent to impact at stroke end (when stopper collides).

Note 3) Depending on the shape of the workpiece, multiple moments may occur. When this happens, the sum of the load factors ($\sum \alpha$) is the total of all such moments.

B. Reference formula [Dynamic moment at impact]

Refer to following calculation for dynamic moment considering the impact when stopper collides.

- W : Mass (kg)
- F : Load (N)
- F_E : Load equivalent to impact (when stopper collides) (N)
- ν : Average speed (mm/s)
- M : Static moment (N·m)
- ν : Collision speed (mm/s)
- L : Distance to the center of load gravity (m)
- M_E : Dynamic moment (N·m)
- g : Gravitational acceleration (9.8 m/s²)

$$\nu = 1.4 \nu a \text{ (mm/s)} \quad F_E = \frac{1.4}{100} \nu a \cdot g \cdot W$$

$$\therefore M_E = \frac{1}{3} \cdot F_E \cdot L = 0.05 \nu a g W L_1 \text{ (N·m)}$$

Note 4) Average load coefficient (This coefficient is meant to average the maximum load moment at the time of impact with stopper in the light of calculating the service life.)

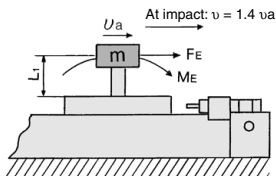

Maximum Load Mass

Select the maximum load mass to be applied within the limits shown in the graph. Note that the maximum allowable moment may in some cases exceed Maximum allowable moment despite being within the limit shown in the graph; therefore, allowable moment on operating conditions should be checked.

ML1C/W₁

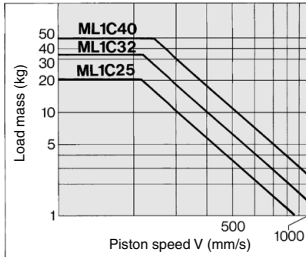

ML1C/W₂

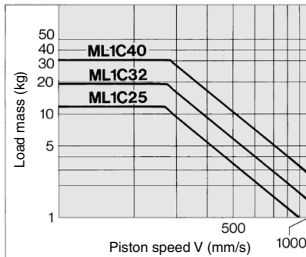

ML1C/W₃

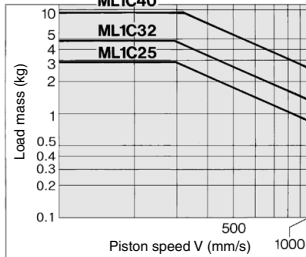

ML1C/W₄

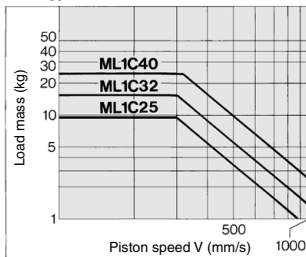

Caution on Pneumatic Circuit Design

Operating pneumatic circuit

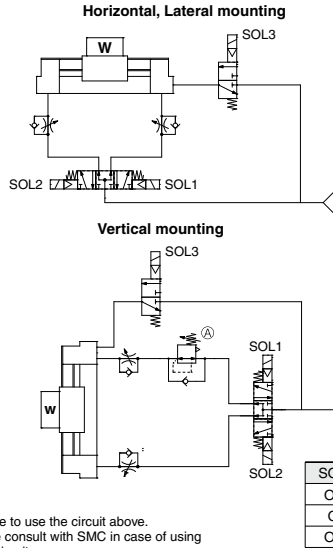

* Be sure to use the circuit above.
Please consult with SMC in case of using other circuits.

Solenoid Valve for Driving and Braking

<Solenoid valve for driving>

Use pressure center style valve.
Control the operation with a meter-out system.

<Solenoid valve for braking>

- Use the solenoid valve for braking which has the effective area equivalent to the one of solenoid valve for driving. If the effective area is smaller, it may encounter an unexpected sudden slide table movement.
- Install a solenoid valve for braking as close to the cylinder as possible. If there is a long distance between the cylinder and valve, it may cause fluctuations in the stop accuracy or unexpected sudden slide table movements.

<Recommended solenoid valve example>

	Horizontal, lateral mounting	Vertical
Solenoid valve for driving	VFS2500	
Solenoid valve for braking	VP300 or VFS2100	

* Determine the size of the solenoid valve according to the operating cylinder speed.

Air Balance

On both above mentioned circuit, the air balance is made by pressurizing to both sides of cylinder on the condition of the intermediate stop.
In the case of the vertical orientation, reduce the pressure of the upside by regulator (check valve) (A) to keep the balance is not made, it may cause unexpected sudden slide table movements after the intermediate stop operation, once the reverse operation occurs, resulting in compromised accuracy of the cylinder.

Supply Pressure

- Set the supply pressure at 0.25 to 0.5 MPa. If setting at less than 0.25 MPa, malfunction of the release brake may occur.
- If line pressure is used directly as supply pressure, any fluctuation in pressure will appear in the form of changes in cylinder characteristics. Therefore, make sure to use a pressure regulator to convert line pressure into supply pressure for the actuating valve and the brake valve. In order to actuate multiple cylinders at once, use a pressure regulator that can handle a large air flow volume and also consider installing a surge tank.

CLJ2

CLM2

CLG1

CL1

MLGC

CNG

MNB

CNA2

CNS

CLS

CLQ

RLQ

MLU

MLGP

ML1C

D-□

-X□

Mechanically Jointed Hy-rodless Cylinder with Brake

Series *ML1C*

∅25, ∅32, ∅40

How to Order

Hy-rodless cylinder
(With brake)

ML1C **25** **G** - **300** **H** - **M5BW** **□** - **□**

Bore size (mm) *

25	25 mm
32	32 mm
40	40 mm

Cylinder stroke *

Bore size (mm)	Standard stroke (mm)*	Maximum manufacturable stroke (mm)
25	100, 200, 300, 400, 500, 600, 700, 800, 900, 1000	2000
32	100, 200, 300, 400, 500, 600, 700, 800, 900, 1000	2000
40	100, 200, 300, 400, 500, 600, 700, 800, 900, 1000	2000

* When stroke is required, which is longer than the standard stroke, refer to the "Made to Order Specifications" for long stroke type (XB11).

• **Made to Order**
Refer to page 1029 for details.

• **Number of auto switches**

Nii	2 pcs.
S	1 pc.
n	"n" pcs.

• **Auto switch**

Nii	Without auto switch (Built-in magnet)
------------	---------------------------------------

* For the applicable auto switch model, refer to the table below.

* Auto switches are shipped together (not assembled).

• **Stroke adjustment unit symbol**

Refer to page 1029 for stroke adjustment unit.

Applicable Auto Switches/Refer to pages 1893 to 2007 for further information on auto switches.

Type	Special function	Electrical entry	Indicator light	Wiring (Output)	Load voltage		Auto switch model	Lead wire length (m)*			Pre-wired connector	Applicable load		
					DC	AC		0.5 (Nii)	3 (L)	5 (Z)		IC circuit	Relay, PLC	
Solid state auto switch	—	Grommet	Yes	3-wire (NPN)	24 V	5 V, 12 V	—	M5N	●	●	●	○	IC circuit	Relay, PLC
				3-wire (PNP)				M5P	●	●	●	○	IC circuit	
				2-wire				M5B	●	●	●	○	—	
	Diagnostic indication (2-color indication)			3-wire (NPN)	5 V, 12 V	M5NW	●	●	●	○	IC circuit			
				3-wire (PNP)		M5PW	●	●	●	○	IC circuit			
				2-wire		M5BW	●	●	●	○	—			
				3-wire (NPN)		M5NT	—	●	●	○	IC circuit			
With timer	3-wire (PNP)	5 V, 12 V	M5PT	—	●	●	○	IC circuit						
	3-wire (NPN equivalent)		—	5 V	—	E76A	●	●	—	—	IC circuit	—		
Reed auto switch	—	Grommet	Yes	2-wire	24 V	12 V	100 V	E73A	●	●	—	—	—	Relay, PLC
				5 V, 12 V		100 V or less	E80A	●	●	—	—	IC circuit		
				NO		—	—	—	—	—	—	—		

* Lead wire length symbols: 0.5 m.....Nii (Example) M5BW
3 m.....L (Example) M5BWL
5 m.....Z (Example) M5BWZ

* Solid state auto switches marked with "○" are produced upon receipt of order.

* For details about auto switches with pre-wired connector, refer to pages 1960 and 1961.

* Auto switches are shipped together (not assembled). (For details about auto switch mounting, etc., refer to page 1036.)



Made to Order Specifications
(For details, refer to pages 2033 to 2152.)

Symbol	Specifications
-XB11	Long stroke type

Cylinder Specifications

Bore size (mm)	25	32	40
Guide type	Cam follower guide type		
Fluid	Air		
Action	Double acting		
Operating pressure range (MPa)	0.1 to 0.8		
Proof pressure (MPa)	1.2		
Ambient and fluid temperature	5 to 60°C (No freezing)		
Piston speed (mm/s)	100 to 1000		
Cushion	Air cushion		
Lubrication	Not required (Non-lube)		
Stroke length tolerance (mm)	+1.8 0		
Port size Rc	Front port, Side port, Bottom port		1/8
			1/4

Brake Specifications

Lock operation	Spring locking (Exhaust lock)
Fluid	Air
Maximum operating pressure (MPa)	0.5
Brake releasing pressure (MPa)	0.25
Brake activating pressure (MPa)	0.18
Braking direction	Both directions

Stroke Adjustment Unit Specifications

Applicable cylinder size (mm)	25	32	40
Unit symbol	H	H	H
Configuration Shock absorber model	RB1412 + with adjustment bolt	RB1412 + with adjustment bolt	RB2015 + with adjustment bolt
Stroke adjustment range by intermediate fixing spacer (mm)	Without spacer	0 to -11.5	0 to -16
	With short spacer	-11.5 to -23	-12 to -24
	With long spacer	-23 to -34.5	-24 to -36

* Stroke adjustment range is applicable for one side when mounted on a cylinder.

* The shock absorber service life is different from that of the ML1C cylinder depending on the operating conditions. Refer to the Specific Product Precautions for the replacement period.

Stroke Adjustment Unit Symbol

		Right side stroke adjustment unit				
		Without unit	H: With high load shock absorber + Adjustment bolt			
			With short spacer	With long spacer		
Left side stroke adjustment unit	Without unit	Nil	SH	SH6	SH7	
	H: With high load shock absorber + Adjustment bolt	HS	H	HH6	HH7	
		With short spacer	H6S	H6H	H6	H6H7
		With long spacer	H7S	H7H	H7H6	H7

* Spacers are used to fix the stroke adjustment unit at an intermediate stroke position.

Stroke Adjustment Unit Shock Absorber Model

ø25	ø32	ø40
RB1412	RB2015	RB2015

Shock Absorber Specifications

Applicable cylinder size (mm)	25	32	40
Shock absorber model	RB1412	RB2015	RB2015
Max. energy absorption (J)	19.6	58.8	58.8
Stroke absorption (mm)	12	15	15
Max. collision speed (mm/s)	1000	1000	1000
Max. operating frequency (cycle/min)	45	25	25
Spring force (N)	Extended	6.85	8.34
	Retracted	15.98	20.50
Operating temperature range (°C)	5 to 60		

* Stroke adjustment range is applicable for one side when mounted on a cylinder.

* The shock absorber service life is different from that of the ML1C cylinder depending on the operating conditions. Refer to the Specific Product Precautions for the replacement period.

Stroke adjustment unit mounting diagram

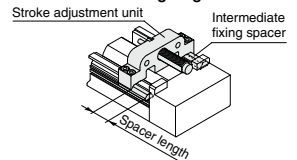

Example of H7H6 attachment

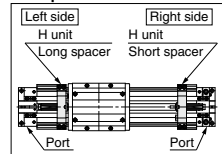

CLJ2

CLM2

CLG1

CL1

MLGC

CNG

MNB

CNA2

CNS

CLS

CLQ

RLQ

MLU

MLGP

ML1C

D-□

-X□

Series ML1C

Theoretical Output

Bore size (mm)	Piston area (mm ²)	Operating pressure (MPa)						
		0.2	0.3	0.4	0.5	0.6	0.7	0.8
25	490	98	147	196	245	294	343	392
32	804	161	241	322	402	483	563	643
40	1256	251	377	502	628	754	879	1005

Weight

Bore size (mm)	Basic weight	Additional weight per each 50 mm of stroke	Side support weight (per set)		Stroke adjustment unit weight (per unit)
			Type A	Type B	
25	3.86	0.275	0.015	0.016	0.25
32	6.05	0.425	0.040	0.041	0.41
40	8.38	0.545	0.076	0.080	0.50

Option

Stroke Adjustment Unit Model

ML1 - A 25 H - 6N

Cylinder bore size
Stroke adjustment unit
Unit part no.
Intermediate fixing spacer

25	25 mm
32	32 mm
40	40 mm

Symbol	Stroke adjustment unit	Mounting position
H	H unit	For both sides

Note) For details about adjustment range, refer to page 1029.

Nil	Without spacer
6	Short spacer
7	Long spacer

Nil	Assembled as a unit
N	Spacer only

Spacer shipping method

Nil	Assembled as a unit
N	Spacer only

- Spacers are used to fix the stroke adjustment unit at an intermediate stroke position.
- Spacers are shipped in 2 piece sets.

Components Parts

Model	ML1-A25H2 (Without spacer)	ML1-A25H2-6 (With short spacer)	ML1-A25H2-7 (With long spacer)	ML1-A25H2-6N (Short spacer only)	ML1-A25H2-7N (Long spacer only)
Diagram					
Labels		Short spacer	Long spacer	Short spacer	Long spacer

Side Support Part No.

Type	Bore size (mm)	25	32	40
Side support A		MY-S25A	MY-S32A	MY-S40A
Side support B		MY-S25B	MY-S32B	MY-S40B

For details about dimensions, etc., refer to page 1034.

Construction Principle of Brake

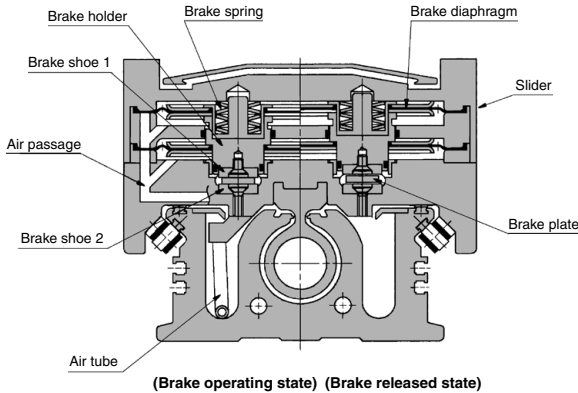

[Anatomy of Brake Operation]

Spring force generated by the brake spring works on a brake shoe 1 fixed to the brake holder, bend brake plate fixed on head cover on both sides, brake rails and holds brake plate between brake shoe 1 and brake shoe 2 fixed to slider side so that slider will stop.

[Brake releasing]

Air pressure supplied from the head cover side goes to the slide table through the air tube and acts on the brake diaphragm, reducing the spring.

Brake Capacity

Holding Force (Maximum static load)

Bore size (mm)	25	32	40
Holding force	320N	500N	800N

- The holding force is the lock's ability to hold a static load that does not involve vibrations or shocks, after it is locked without a load. Therefore, to use the cylinder near the upper limit of the constant holding force, be aware of the following:
 - Select the cylinder bore size so that the load is less than 80% of the holding force.
 - If slipping occurs when the load is over holding force, the brake shoe will be damaged, and it is possible the holding force will become smaller or the cylinder life shortened.

Allowable Kinetic Energy

Bore size (mm)	25	32	40
Allowable kinetic energy (J)	0.43	0.68	1.21

Overrun

Overrun

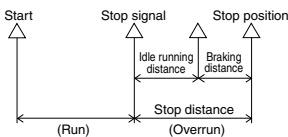

Overrun model

When cylinder is stopped at intermediate strokes, "idle running distance" is from detection of stop signal to beginning of brake operation and "braking distance" is from beginning of brake operation to the stop of slider.

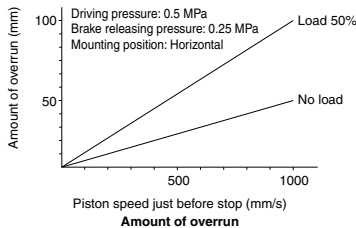

The graph above shows the relation between piston speed and overrun. (The length of overrun is changed, dependent on piston speed, load, piping conditions and control method. Be sure to adjust the stop signal position, etc. by trial operation with the actual machine.)

Stop dispersion

When cylinder is stopped at intermediate stroke, there is dispersion of stop position. Dispersion of stop position is changed dependent on piston speed, load, piping condition and control method. Use values in the table below as reference.

Stopping Accuracy

Piston speed (mm/s)	100	300	500	800	1000
Stopping accuracy (mm)	±0.5	±1.0	±2.0	±3.0	±4.0

Conditions Driving pressure: 0.5 MPa
 Brake releasing pressure: 0.25 MPa
 Load: 25%
 Solenoid valve for releasing brake is connected to cylinder directly. Dispersion of the control system is not included.

CLJ2

CLM2

CLG1

CL1

MLGC

CNG

MNB

CNA2

CNS

CLS

CLQ

RLQ

MLU

MLGP

ML1C

D-□

-X□

Manual Operation

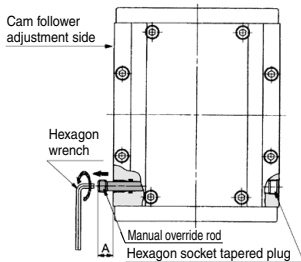

Warning

In the case of manual operation, be sure to supply air for brake releasing. If not, this may result in damage to the brake, which will cause a cylinder malfunction.

[Brake releasing]

1. Supply the air for releasing the brake to the braking air port on the head cover. This should be 0.4 to 0.5 MPa.
2. Loosen the manual override (nickel plated) rod on the slide table by using a hexagon wrench, and draw the rod until it reaches to the end. The size of the hexagon wrench should be 3 mm (ML1C25, 32) or 4 mm (ML1C40).
3. Exhaust the air to release the brake.

Manual Rod Drawing Dimensions

Model	A
ML1C25	23
ML1C32	27
ML1C40	32

[Brake operation]

1. Supply the air for releasing the brake to the braking air port on the head cover. This should be 0.4 to 0.5 MPa.
2. Push the manual rod and then screw it until it is housed inside a slider completely.
3. Exhaust the air to release the brake.

Cushion Capacity

Cushion selection

<Air cushion>

Air cushion is standard on Hy-rodless cylinder. The air cushion mechanism is incorporated to prevent excessive impact of the piston at the stroke end during high speed operation.

Air cushion is not applied for slow piston operation around the stroke end.

A range of the mass and speeds that an air cushion can absorb is within the limits shown in the graph, "Air Cushion Absorbing Capacity".

<Stroke adjustment unit with shock absorber>

Use this unit to decelerate the cylinder when mass and speed are beyond the air cushion limit lines or when the stroke adjustment causes limited or no cushion engagement.

Note)

1. Adjust the shock absorber so that stroke will be fully utilized to near the limit of allowable energy, because absorption capacity becomes extremely small if the absorber's effective stroke is short due to a stroke adjustment.
2. When the shock absorber is used within the air cushion stroke range, almost open the air cushion needle (about 1 turn from the fully closed position).

Air Cushion Stroke (mm)

Bore size (mm)	Cushion stroke
ø25	15
ø32	19
ø40	24

Air Cushion Absorption Capability

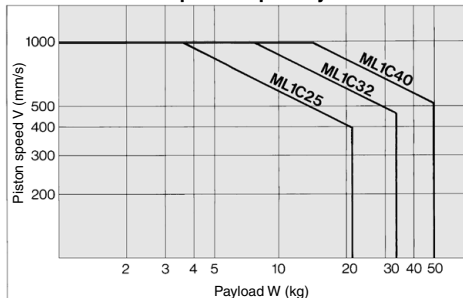

Stroke Adjusting Unit with Shock Absorber/ Calculation of Absorbed Energy

Type of impact	Horizontal collision	Vertical (Downward)	Vertical (Upward)
Kinetic energy E_1	$\frac{W}{2} \cdot V^2$		
Thrust energy E_2	F·s	F·s + W·s·g	F·s - W·s·g
Absorbed energy E	$E_1 + E_2$		

Symbol

V: Impact speed (m/s) g: Gravitational acceleration (m/s²)

W: Impact object mass (kg) F: Cylinder thrust (N)

s: Stroke length of shock absorber (m)

Note) The speed of the impact object is measured at the moment of impact with the shock absorber.

Adjusting Procedure

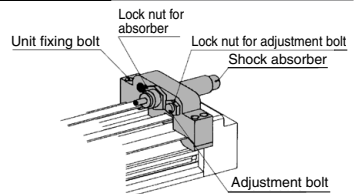

<Moving and fixing unit>

Remove the dust proof cover, loosen the four fixing bolts to move the unit body.

The unit body can be fixed by tightening four holding bolts evenly at an arbitrary position. However, there is a possibility that the adjustment mechanism will be tilted due to high impact energy. Since the holder mounting bracket for adjustment is available as an option for -X416, -X417, we recommend that you use it. Please refer to holder mounting bracket in Made to Order Specifications (2). If any other length is desired, please consult with SMC.

<Stroke adjusting of adjustment bolt>

After loosening the lock nut for adjustment bolt, adjust the stroke with hexagon wrench. Then, tighten lock nut.

<Stroke adjusting of shock absorber>

After loosening the lock nut for the shock absorber, adjust the stroke by rotating shock absorber, then fix the shock absorber by tightening lock nut. Do not over tighten the lock nut.



Basic Type

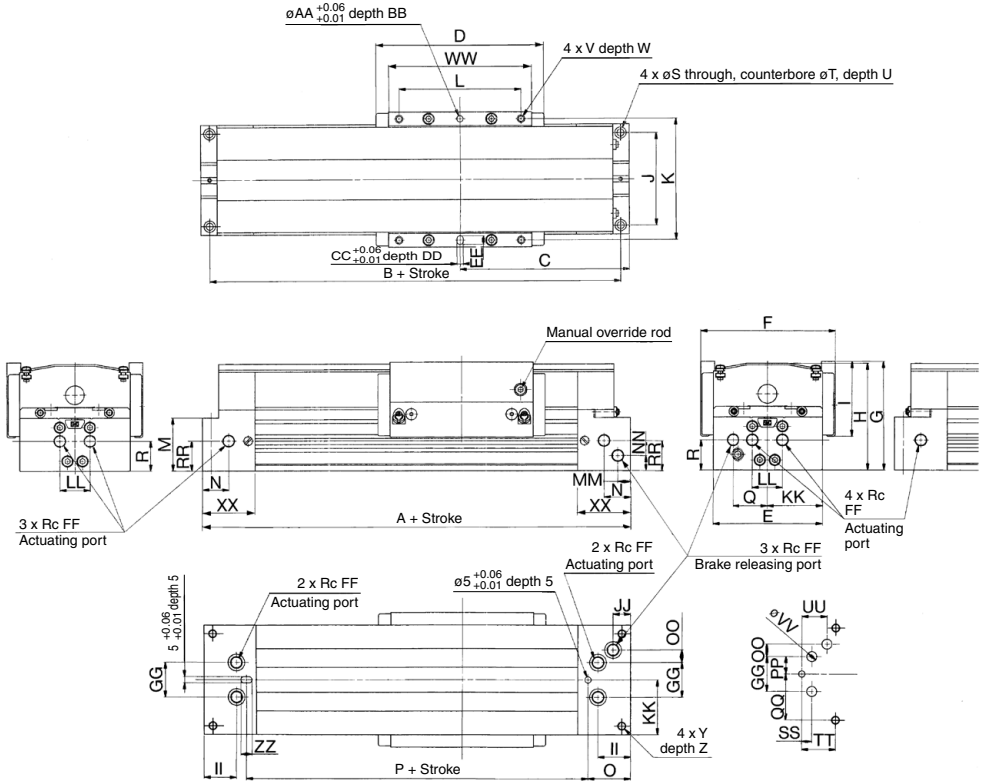

- CLJ2
- CLM2
- CLG1
- CL1
- MLGC
- CNG
- MNB
- CNA2
- CNS
- CLS
- CLQ
- RLQ
- MLU
- MLGP
- ML1C**

Bottom Side Piping Port Size

(Mounting side should be processed according to the dimensions below.) (mm)

Model	OO	PP	QQ	RR	SS	TT	UU	VV	Applicable gasket
ML1C25	10	14	37	24	8	27	20	8	C11.2
ML1C32	16.5	18	46	30	6.8	11	6.6	M6 x 1	M8 x 1.25 C11.2
ML1C40	17	23.5	53	40	12.5	34	26	10	C14

Model	A	B	C	D	E	F	G	H	I	J	K	L	M	N	O	P	Q	R	S	T	U	V	W	Y	Z
ML1C25	274	260	137	140	88	108	87	85.5	60	74	97	100	42.5	26	34	206	28	24	5.6	9	5.5	M5 x 0.8	8.5	M6 x 1	9.5
ML1C32	322	306	161	160	108	131	101	99.5	64	92	118	120	53.5	28	40	242	36.5	30	6.8	11	6.6	M6 x 1	12	M8 x 1.25	16
ML1C40	372	354	186	190	124	158	118	116.5	73	106	144	140	64	30.5	43	286	40.5	35	8.6	14	8.5	M8 x 1.25	14	M10 x 1.5	15

Model	AA	BB	CC	DD	EE	FF	GG	II	JJ	KK	LL	MM	NN	WW	XX	ZZ
ML1C25	5	5	5	5	7	1/8	28	26	14	44	20	16	12.5	120	42	8
ML1C32	6	5	6	5	8	1/8	36	28	18	54	36	18	12.5	140	48	8
ML1C40	6	5	6	5	8	1/4	47	30.5	17	62	30	22	16.5	170	51	10

- D-
- X

Series ML1C

Stroke Adjustment Unit

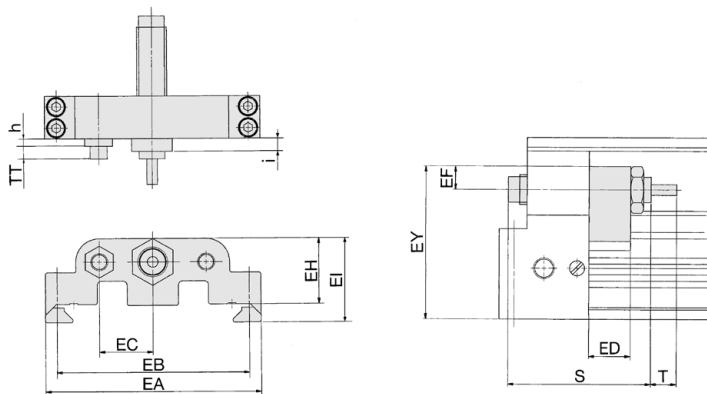

Part no.	Applicable bore	EA	EB	EC	ED	EF	EY	S	T	EH	EI	TT	h	i	Shock absorber model
ML1-A25H	ML1C25	101	90	25	20	11	72	67.3	12	31	39.5	Max. 16.5	4.5	3	RB1412
ML1-A32H	ML1C32	120	107	30	25	16	93	73.2	15	38	49	Max. 20	5.5	6	RB2015
ML1-A40H	ML1C40	147	129	30	31	16	105.5	73.2	15	40.5	54.5	Max. 25	5.5	6	

Side Support

Side support A

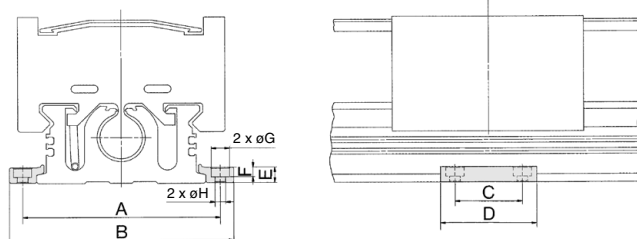

Side support B

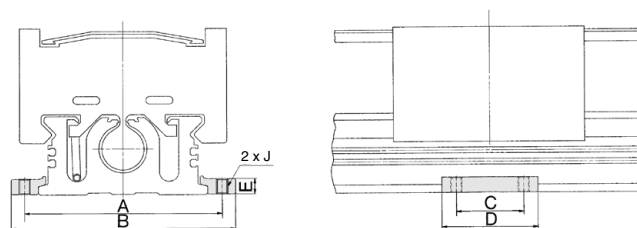

(mm)

Part no.	Applicable bore	A	B	C	D	E	F	G	H	J
MY-S25 ^A	ML1C25	103	117	35	50	8	5	9.5	5.5	M6 x 1
MY-S32 ^B	ML1C32	128	146	45	64	11.7	6	11	6.6	M8 x 1.25
MY-S40 ^A	ML1C40	148	170	55	80	14.8	5	14	9	M10 x 1.5

Construction

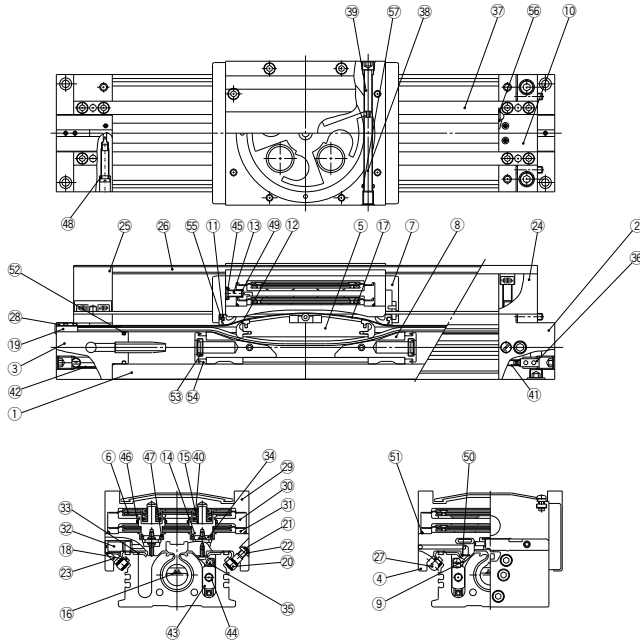

Component Parts

No.	Description	Material	Note
1	Cylinder tube	Aluminum alloy	Hard anodized
2	Head cover WR assembly	Aluminum alloy	Hard anodized
3	Head cover WL assembly	Aluminum alloy	Hard anodized
4	Slide table	Aluminum alloy	Hard anodized
5	Piston assembly	Aluminum alloy	Hard anodized
6	Brake diaphragm assembly	—	
7	End Cover	Chrome molybdenum steel	Nickel plated
8	Wear ring	Special resin	
9	Air joint assembly	—	
10	Plate tensile table	Rolled steel	Nickel plated
11	Stopper	Carbon steel	Nickel plated
12	Belt separator	Special resin	
13	Port joint	Stainless steel	
14	Brake holder assembly	Carbon steel	Gas soft nitrided
15	Spring holder	Carbon steel	Gas soft nitrided
16	Seal belt	Special resin	
17	Dust seal band	Stainless steel	
18	Rail	Hard steel wire material	
19	Belt clamp	Special resin	
20	Cam follower	—	
21	Eccentric screw cap	Stainless steel	
22	Lock nut	Stainless steel	
23	Bushing	Stainless steel	
24	Dust proof cover mountable R	Aluminum alloy	Hard anodized
25	Dust proof cover mountable L	Aluminum alloy	Hard anodized
26	Dust cover	Aluminum alloy	Hard anodized
27	Magnet assembly	Aluminum alloy	Anodized
28	Seal lock plate	Rolled steel	Nickel plated
29	Slider cover assembly	Aluminum alloy	Hard anodized
30	Diaphragm plate assembly	Aluminum alloy	Chromated
31	Diaphragm ring	Aluminum alloy	Chromated (ø25 only)

Component Parts

No.	Description	Material	Note
32	Cam follower cap	Aluminum alloy	Hard anodized
33	Tube cover	Aluminum alloy	Hard anodized
34	Brake shoe	Special friction material	
35	Joint ring	Stainless steel	
36	Air coupler 2	Stainless steel	
37	Brake plate	Stainless steel	Hard chrome plated
38	Manual rod 1	Carbon steel	Nickel plated
39	Manual rod 2	Carbon steel	Chromated
40	Brake spring		
41	Air tube	Special resin	
42	Cable	Stainless steel	
43	Tube guide assembly		
44	Guide tube	Stainless steel	
45	Tension rod	Rolled steel	Nickel plated
46	Spacer	Stainless steel	
47	O-ring	NBR	
48	O-ring	NBR	
49	O-ring	NBR	
50	Needle gasket	NBR	
51	O-ring	NBR	
52	O-ring	NBR	
53	O-ring	NBR	
54	Tube gasket	NBR	
55	Cushion seal	NBR	
56	Piston seal	NBR	
57	Scraper	NBR	
58	Bypass gasket	NBR	
59	O-ring	NBR	

- CLJ2
- CLM2
- CLG1
- CL1
- MLGC
- CNG
- MNB
- CNA2
- CNS
- CLS
- CLQ
- RLQ
- MLU
- MLGP
- ML1C**

- D-□
- X□

Series ML1C Auto Switch Mounting

Auto Switch Proper Mounting Position (Detection at Stroke End)

D-E7□A, D-E80A

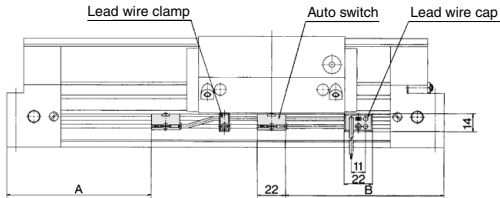

Note) Position auto switch's indicator sight toward the slide table side.

Lead Wire Clamp/Lead Wire Cap (Option)

Series	Lead wire clamp	Lead wire cap
ML1C	LC-01	LP-01

Series	Mounting position	ø25	ø32	ø40
		ML1C	A	128.5
	B	123.5	147.5	172.5

D-M5□
D-M5□W
D-M5□T

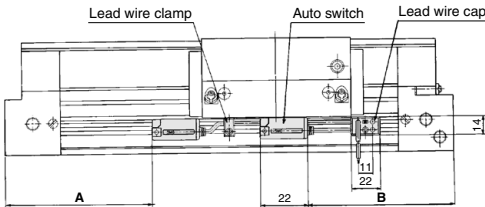

Lead Wire Clamp/Lead Wire Cap (Option)

Series	Lead wire clamp	Lead wire cap
ML1C	LC-01	LP-01

Series	Mounting position	(mm)		
		ø25	ø32	ø40
ML1C	A	124.8	148.8	173.8
	B	113.2	137.2	162.2

Minimum Stroke for Auto Switch Mounting

No. of auto switches mounted	Applicable auto switch (mm)	
	D-E7□A, D-E80A	D-M5□, D-M5□W, D-M5□T
1 pc.	10	5
2 pcs.	15	10

Auto Switch Mounting Bracket: Part No.

Bore size (mm)	Auto switch mounting bracket part no.	Note	Auto switch model
25 32 40	BM-Y1-025	<ul style="list-style-type: none"> Switch mounting screw M2.5 x 10 L Switch mounting nut 	D-E7□A-80A
	BM-Y2-025	<ul style="list-style-type: none"> Switch mounting screw M2.5 x 12 L Switch mounting nut 	D-M5□ D-M5□W D-M5□T

Operating Range

Auto switch model	Bore size (mm)		
	25	32	40
D-E7□A, E80A	6	6	6
D-M5□, M5□W, M5□T	4	4	4

* Since this is a guideline including hysteresis, not meant to be guaranteed. (Assuming approximately ±30% dispersion.)

There may be the case it will vary substantially depending on an ambient environment.



Series ML1C

Specific Product Precautions

Be sure to read before handling. Refer to front matter 39 for Safety Instructions and pages 3 to 12 for Actuator and Auto Switch Precautions.

Adjustment

⚠ Caution

1. Even though hy-rodless cylinders can be loaded within the maximum allowable moment and payload, precise alignment is required if connected to a payload which has an external support structure.

As the stroke becomes longer, variations in the center axis become larger. Consider using a connection method (floating mechanism) that is able to absorb deflection.

2. Due to the factory pre-adjusted guide and brake plate, readjustment is not required under normal operating conditions.

Therefore, do not unnecessarily alter the guide adjustment setting.

3. Do not operate the cylinder in an environment in which the cylinder will be exposed to cutting chips, dust (paper debris, lint, etc.), spatter or cutting fluid (gas oil, water (warm water), etc.), which could lead to operational problems.

4. It is recommended that grease be applied periodically to the sliding portion of the bearing and to the dust seal band to increase their service life.

5. Take precautions under operating conditions in which negative pressure is generated inside the cylinder by external forces or inertial forces. Air leakage may occur due to separation of the seal belt. Do not generate negative pressure in the cylinder by forcibly moving it with an external force during the trial operation or dropping it with self-weight under the non-pressure state, etc.

When the negative pressure is generated, slowly move the cylinder by hand and move the stroke back and forth. After doing so, if air leakage still occurs, consult with SMC.

6. Since the hy-rodless cylinders have a unique seal structure, a slight speed change may occur.

For applications that require constant speed, select an applicable equipment for the level of demand.

7. The hy-rodless cylinder does not guarantee traveling parallelism. When accuracy in traveling parallelism and a middle position of stroke is required, consult with SMC.

8. When the cylinder is used extremely infrequently, operation may be interrupted in order for anchoring and a change lubrication to be performed or service life may be reduced.

9. Mount a cylinder after confirming the cylinder tube is not twisted.

If flatness of the mounting surface is not sufficient, the cylinder tube may be twisted, which may cause air leakage due to separation of the seal belt, damage to a dust seal band, or malfunctions.

Handling Precautions

⚠ Caution

1. Do not scratch or dent the outside surface of the cylinder tube.

This may result in damaged bearings or scrapers, which can cause cylinder malfunction.

Handling Precautions

⚠ Caution

2. Do not apply a load to the dustproof cover.

It may cause malfunction.

3. Since the slide table is supported by precision bearings, do not subject it to strong impact or excessive moment when mounting workpieces.

4. Do not mount a slide table on the fixed equipment surface.

It may cause damage or malfunctions since an excessive load is applied to the bearing.

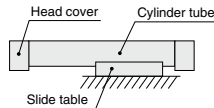

Mounting with a slide table (slider)

5. Consult with SMC when mounting in a cantilevered way.

Since the cylinder body deflects, it may cause malfunctions. Consult with SMC when using it this way.

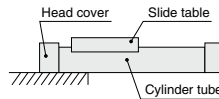

Mounting in a cantilevered way

6. Fixed parts of the cylinder on both ends must have at least 5 mm of contact between where the bottom of the cylinder tube and the equipment surface.

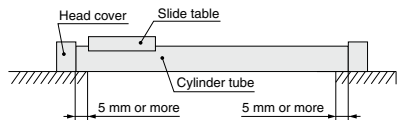

7. Consider uncalculated loads such as piping, cableveyor, etc., when selecting a load moment.

Calculation does not include the external acting force of piping, cableveyor, etc. Select load factors taking into account the external acting force of piping, cableveyor, etc.

Service Life and Replacement Period of Shock Absorber

⚠ Caution

1. Allowable operating cycle under the specifications set in this catalog is shown below.

1.2 million cycles RB08□□

2 million cycles RB10□□ to RB2725

(Note) Specified service life (suitable replacement period) is the value at room temperature (20 to 25°C). The period may vary depending on the temperature and other conditions. In some cases the absorber may need to be replaced before the allowable operating cycle above.

CLJ2

CLM2

CLG1

CL1

MLGC

CNG

MNB

CNA2

CNS

CLS

CLQ

RLQ

MLU

MLGP

ML1C

D-□

-X□