

3-Position Rotary Table

Stop position adjustment range

● From centre: $\pm 10^\circ$

● Rotation range: $0 \sim 95^\circ$

The desired position is adjustable to between 0 and 95° from the centred position to both the right and left hand sides.

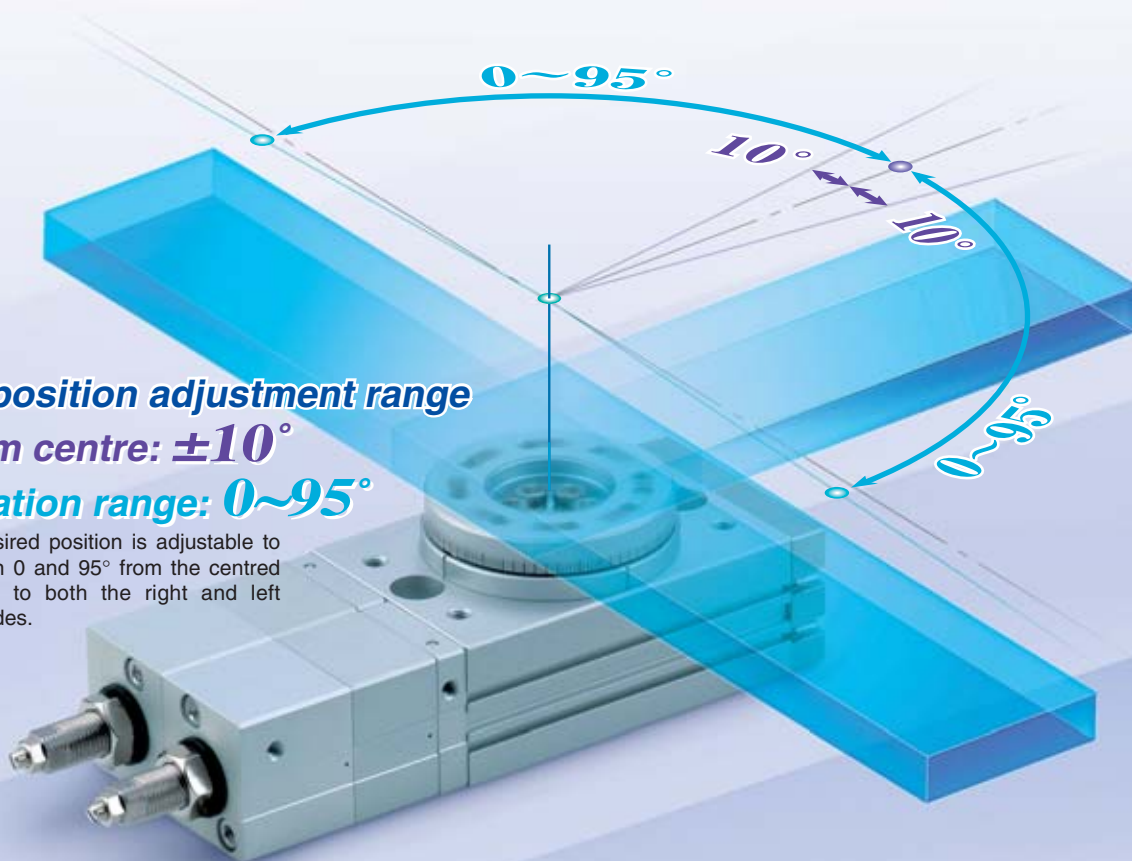

Sorting work to the right and left hand sides

Can be operated by a single valve.

Controllable with one 3-position solenoid valve.

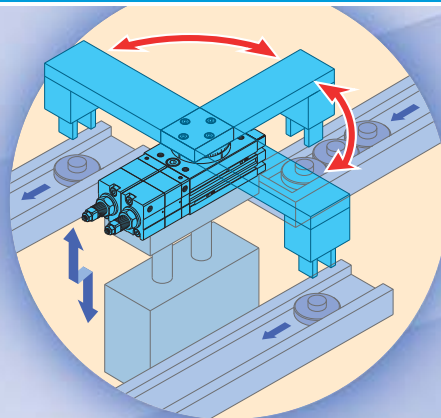
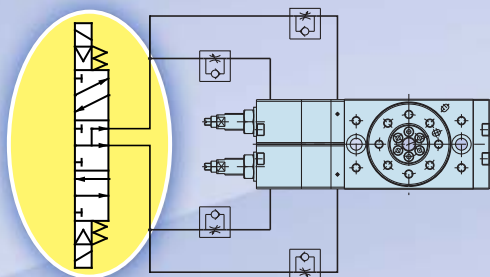

Example of Stop Position Settings

Angle is adjustable as shown below. (CCW: Counterclockwise, C: Centre, CW: Clockwise)

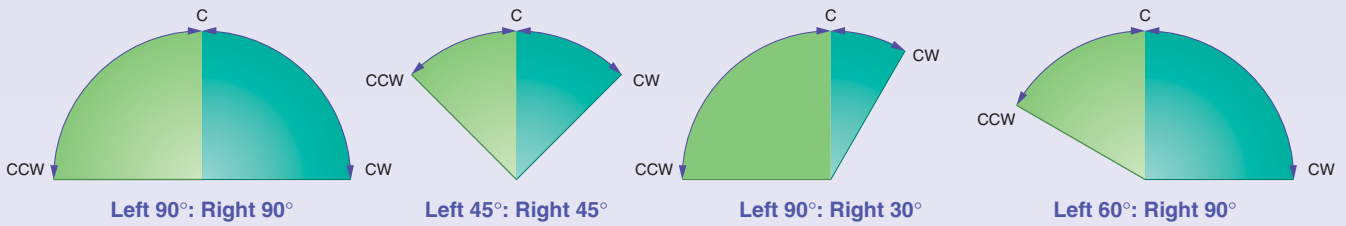

Working Principle

This example uses a 3-position 5-port solenoid valve (pressure centre). When air is supplied to all ports after the solenoid valve is in a pressure-center position, the pistons for rotary operation do not have any thrust, as the pressure on both sides is equal, and the pistons for centre stop move to the centre position due to the thrust of the pistons for centre stop. When all of the pistons (centre stop and rotary operation) are in contact with each other, the piston system stops.

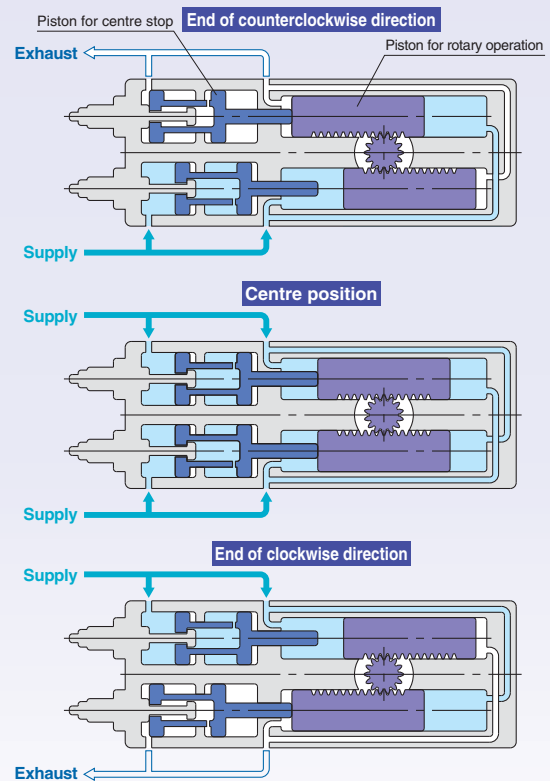
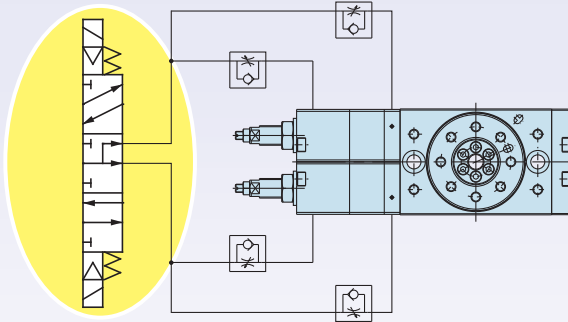

- A load can be mounted directly on the table.
- A High-precision model is also available in addition to the basic model.

Basic model: **MSZB**

High-precision model: **MSZA**

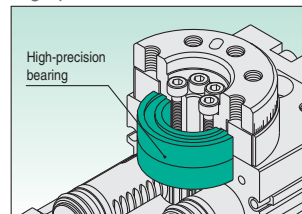
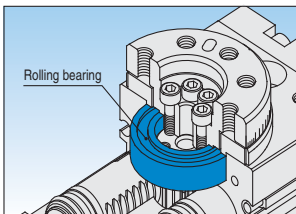

Model	Size	Torque (N-m)	Port size
Basic MSZB	10	1	M5
	20	2	
High-precision MSZA	30	3	
	50	5	



Series MSZ Model Selection

Model Selection Procedure

Formula

Selection Example

1 Operating conditions

Evaluate the operating conditions according to the mounting position.

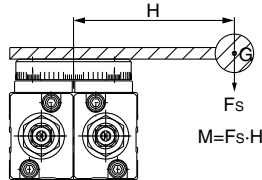

Vertical Mounting

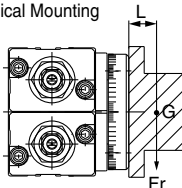

Horizontal Mounting

- Model used
- Operating pressure
- Mounting orientation
- Load type
Static load: T_s (N-m)
Resistance load: T_f (N-m)
Inertia load: T_a (N-m)
- Load configuration
- Rotation time t (s)
- Rotation angle θ (rad)
- Load mass m (kg)
- Distance between central axis and centre of gravity H (m)
- Mass point distance L (m)

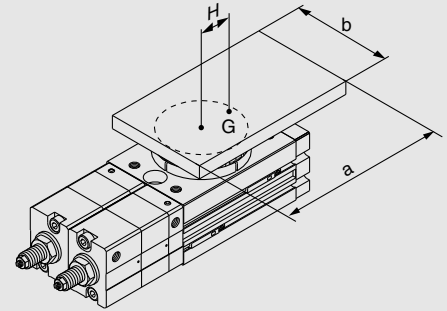

Rotary table: MSZB50A, Pressure: 0.5 MPa
Mounting orientation: Vertical
Load type: Inertial load T_a
Load configuration: 0.1 m x 0.06 m (Rectangular plate)
Rotation time t : 0.3s, Rotation angle: 90°
Load mass m : 0.4 kg
Distance between central axis and centre of gravity H : 0.04 m

2 Required torque

Confirm the type of load as shown below, and select an actuator that satisfies the required torque.

- Static load: T_s
- Resistance load: T_f **Load types**
- Inertial load: T_a

Effective torque $\geq T_s$
Effective torque $\geq (3 \text{ to } 5) \cdot T_f$
Effective torque $\geq 10 \cdot T_a$
Effective torque

Inertial load
 $10 \times T_a = 10 \times I \times \dot{\omega}$
 $= 10 \times 0.00109 \times (2 \times (\pi / 2) / 0.3^2)$
 $= 0.380 \text{ N} \cdot \text{m} < \text{Effective torque OK}$
Note) I substitutes for ⑤ the value for inertial moment.

3 Rotation time

Confirm that it is within the adjustable range of rotation time.

0.2 to 1.0 s / 90°

0.3 s / 90° OK

4 Allowable load

Confirm that the radial load, thrust load and moment are within the allowable ranges.

Thrust load: $m \times 9.8 \leq \text{Allowable load}$
Moment: $m \times 9.8 \times H \leq \text{Allowable moment}$
Allowable load

$0.4 \times 9.8 = 3.92 \text{ N} < \text{Allowable load OK}$
 $0.4 \times 9.8 \times 0.04 = 0.157 \text{ N} \cdot \text{m}$
 $0.157 \text{ N} \cdot \text{m} < \text{Allowable moment OK}$

5 Inertial moment

Find the load's inertial moment "I" for the energy calculation.

$I = m \times (a^2 + b^2) / 12 + m \times H^2$
Inertial moment

$I = 0.4 \times (0.10^2 + 0.06^2) / 12 + 0.4 \times 0.04^2$
 $= 0.00109 \text{ kg} \cdot \text{m}^2$

6 Kinetic energy

Confirm that the load's kinetic energy is within the allowable value.

$1/2 \times I \times \omega^2 \leq \text{Allowable energy}$
 $\omega = 2\theta / t$ (ω : Terminal angular velocity)
 θ : Rotation angle (rad)
 t : Rotation time (s)
Allowable kinetic energy/Rotation time

$1/2 \times 0.00109 \times (2 \times (\pi / 2) / 0.3)^2$
 $= 60 \text{ mJ} < \text{Allowable energy OK}$

Series MSZ

Effective Torque

Unit: N·m

Size	Operating direction	Operating pressure (MPa)								
		0.2	0.3	0.4	0.5	0.6	0.7	0.8	0.9	1
10	End→Centre	0.38	0.60	0.83	1.06	1.28	1.51	1.73	1.96	2.18
	Centre→End	0.29	0.50	0.70	0.90	1.10	1.30	1.51	1.71	1.91
20	End→Centre	0.72	1.14	1.55	1.97	2.39	2.81	3.22	3.64	4.06
	Centre→End	0.62	1.01	1.40	1.78	2.17	2.56	2.95	3.34	3.73
30	End→Centre	1.09	1.72	2.36	3.00	3.63	4.27	4.90	5.54	6.18
	Centre→End	0.91	1.49	2.07	2.65	3.23	3.81	4.39	4.97	5.55
50	End→Centre	1.83	2.83	3.84	4.84	5.84	6.85	7.85	8.85	9.85
	Centre→End				4.75	5.74	6.74	7.73	8.72	9.72

Note) Effective torque values are representative values and not to be considered as guaranteed values.
Torque changes depending on the rotating direction. Please refer to the figure below for the rotating directions.

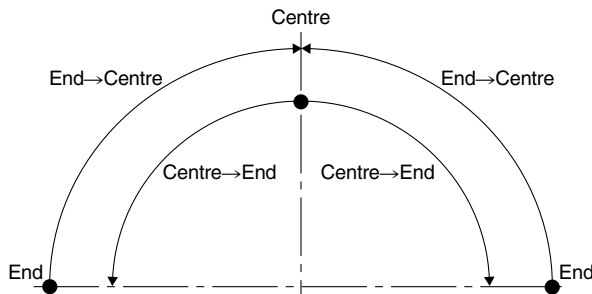

Allowable Load

Do not allow the load and moment applied to the table to exceed the allowable values shown in the table below.

(Operation beyond the allowable values can cause adverse effects on the service life, such as play in the table and loss of accuracy.)

Size	Allowable radial load (N)		Allowable thrust load (N)				Allowable moment (N·m)	
	Basic type	High precision type	(a)		(b)		Basic type	High precision type
			Basic type	High precision type	Basic type	High precision type		
10	78	86	74	74	78	107	2.4	2.9
20	147	166	137	137	137	197	4.0	4.8
30	196	233	197	197	363	398	5.3	6.4
50	314	378	296	296	451	517	9.7	12.0

Load Type

● Static load: Ts

A load as represented by the clamp which requires a pressing force only

(During examination if it is decided to consider the mass of the clamp itself in the drawing below, it should be regarded as an inertial load.)

(Example)

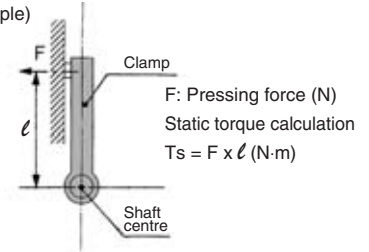

● Resistance load: Tf

A load that is affected by external forces such as friction or gravity

Since the aim is to move the load, and speed adjustment is necessary, allow an extra margin of 3 to 5 times for the effective torque.

*Actuator effective torque $\geq (3 \text{ to } 5) T_f$

(During examination if it is decided to consider the mass of the lever itself in the drawing below, it should be regarded as an inertial load.)

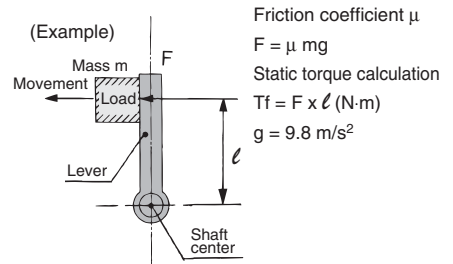

● Inertial load: Ta

A load that must be rotated by the actuator. Since the aim is to rotate the inertial load, and speed adjustment is necessary, allow an extra margin of 10 times or more for the effective torque.

*Actuator effective torque $\geq S \cdot T_a$
(S is 10 times or more)

$$T_a = I \cdot \dot{\omega} \text{ (N·m)}$$

I: Inertial moment

Refer to Front matter 3.

$\dot{\omega}$: Angular acceleration

$$\dot{\omega} = \frac{2\theta}{t^2} \text{ (rad/s}^2\text{)}$$

θ : Rotation angle (rad)

t: Rotation time (s)

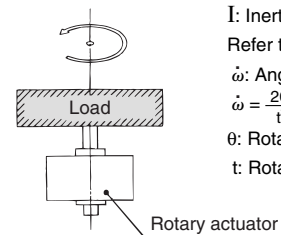

Inertial Moment Formula (Calculation of Inertial Moment I)

I: Inertial moment kg·m² m: Load mass kg

(1) Thin shaft

Position of rotational axis:
Perpendicular to the shaft
through one end

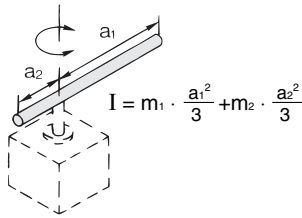

(2) Thin shaft

Position of rotational axis:
Through the shaft's centre of
gravity

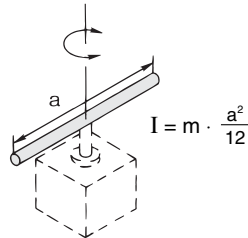

(3) Thin rectangular plate (Rectangular parallelepiped)

Position of rotational axis:
Through the plate's centre of
gravity

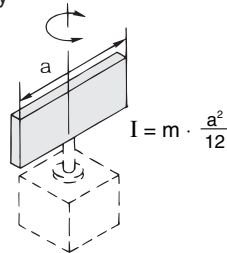

(4) Thin rectangular plate (Rectangular parallelepiped)

Position of rotational axis:
Perpendicular to the plate
through one of its points (also
the same in case of a thicker
plate)

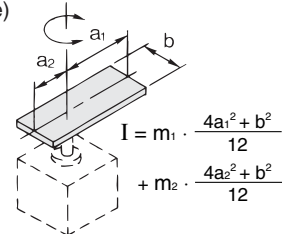

(5) Thin rectangular plate (Rectangular parallelepiped)

Position of rotational axis:
Through the centre of gravity and
perpendicular to the plate (also
the same in case of a thicker
plate)

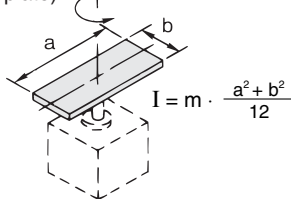

(6) Cylinder (Including thin round plate)

Position of rotational axis:
Centre axis

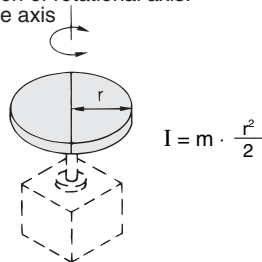

(7) Solid sphere

Position of rotational axis:
Diameter

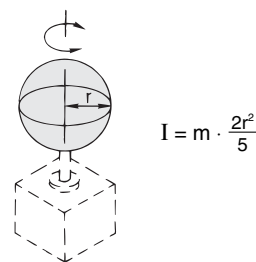

(8) Thin round plate

Position of rotational axis: Diameter

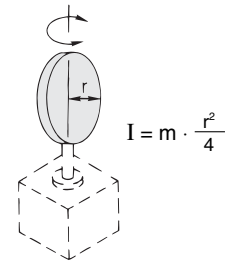

(9) Load at lever end

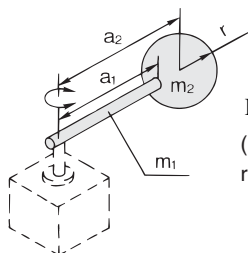

$$I = m_1 \cdot \frac{a_1^2}{3} + m_2 \cdot a_2^2 + K$$

(Example) When shape of m_2 is a sphere,
refer to (7), and $K = m_2 \cdot \frac{2r^2}{5}$

(10) Gear transmission

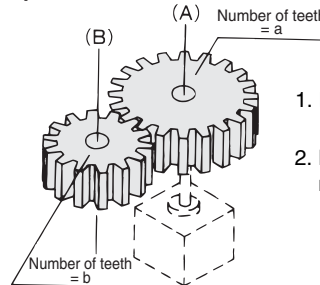

1. Find the inertial moment I_B for the rotation of shaft (B).
2. Next, I_B is entered to find I_A the inertial moment for the rotation of shaft (A) as
$$I_A = \left(\frac{a}{b}\right)^2 \cdot I_B$$

Kinetic Energy/Rotation Time

Even in cases where the torque required for rotation of the load is small, damage to internal parts may result from the inertial force of the load.

Select models giving consideration to the load's inertial moment and rotation time during operation.

(The inertial moment and rotation time charts can be used for your convenience in making model selections on Front matter 4.)

(1) Allowable kinetic energy and rotation time adjustment range

From the table below, set the rotation time within the adjustment range for stable operation. Note that operation exceeding the rotation time adjustment range, may lead to sticking or stopping of operation.

Size	Allowable kinetic energy (mJ)	Rotation time adjustment range for stable operation (s/90°)
10	7	0.2 to 1.0
20	25	
30	48	
50	81	

(2) Inertial moment calculation

Since the formula for inertial moment differ depending on the configuration of the load, refer to the inertial moment calculation formula on this page.

Series MSZ

Kinetic Energy/Rotation Time

(3) Model selection Select models by applying the inertial moment and rotation time which have been found to the chart below.

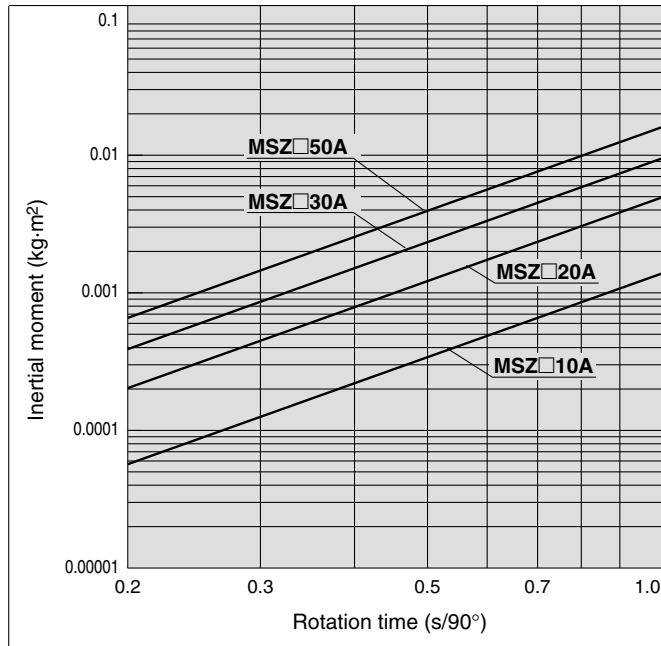

Rotation Accuracy: Displacement Values at 180° (Reference values)

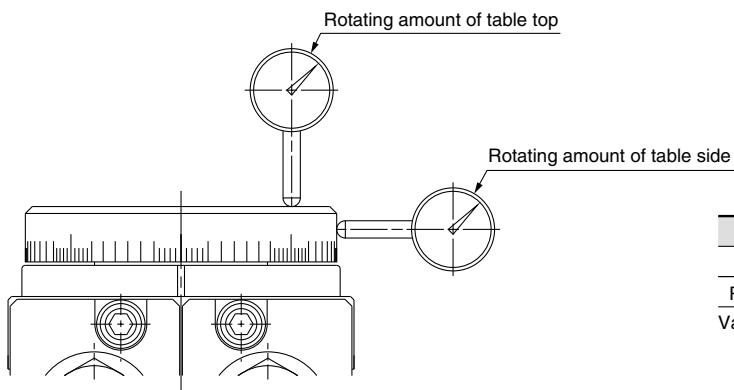

Measuring plate	MSZA	MSZB
Rotating amount of table top	0.03	0.1
Rotating amount of table side	0.03	0.1

Values in the table are actual values and not guaranteed values.

Table Displacement (Reference values)

- The following graphs show the displacement at point A, which is 100 mm away from the centre of rotation, where the load is applied.

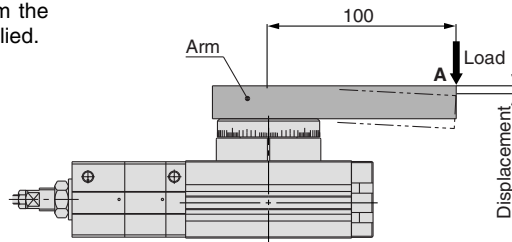

MSZ□10A

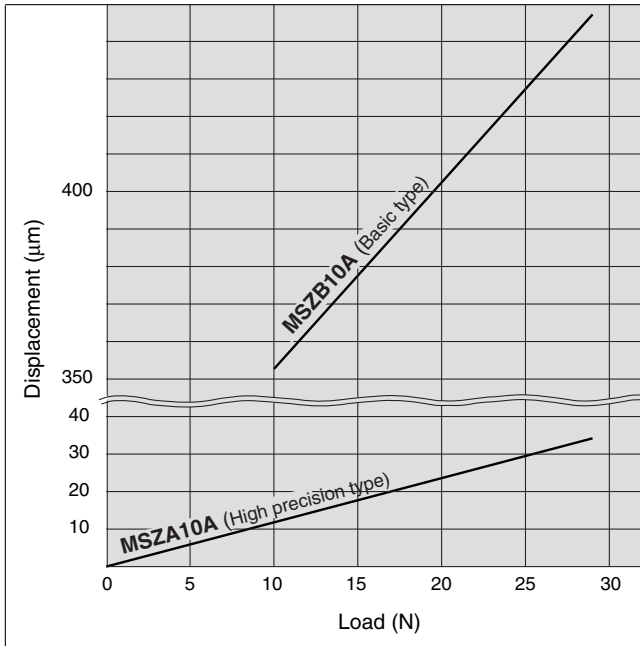

MSZ□20A

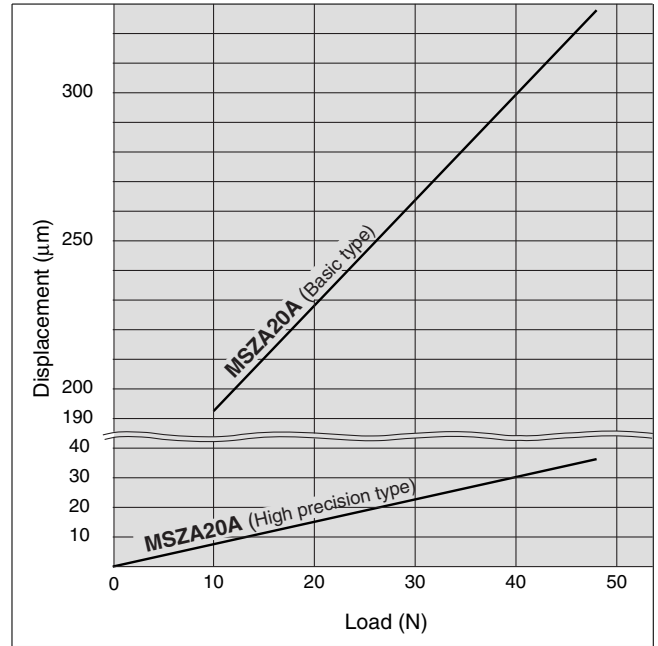

MSZ□30A

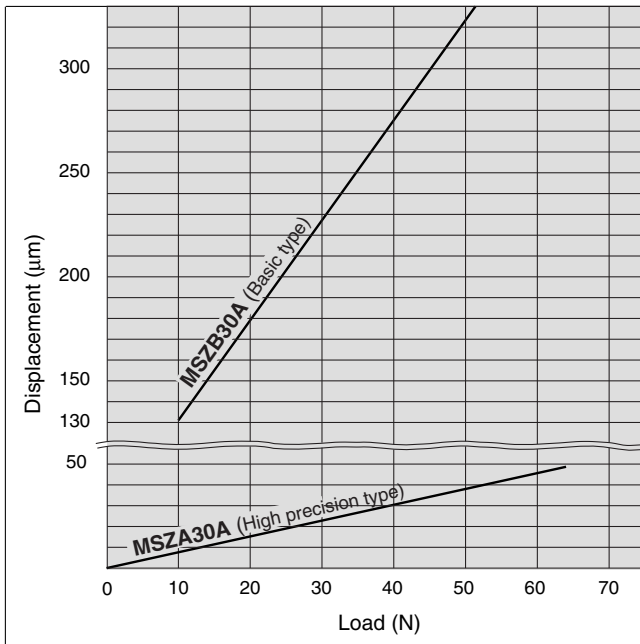

MSZ□50A

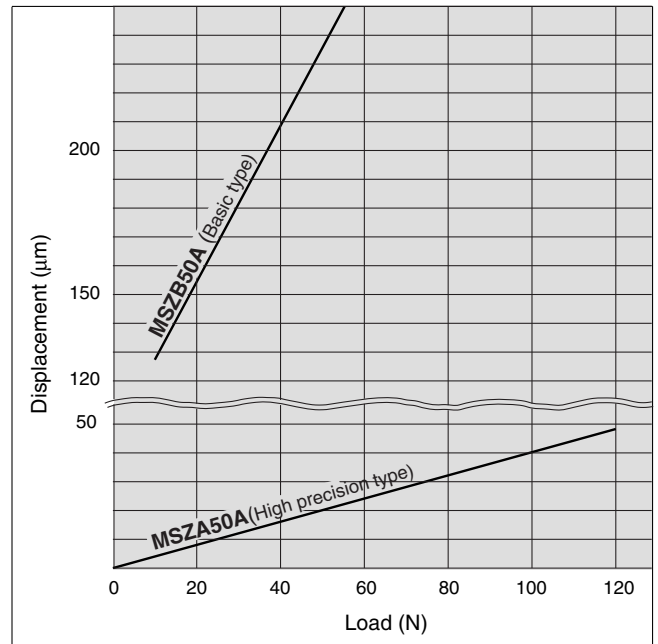

Rotary Table Air Consumption

Air consumption is the volume of air which is expended by the rotary actuator's reciprocal operation inside the actuator and in the piping between the actuator and the switching valve, etc. This is necessary for selection of a compressor and for calculation of its running cost.

$$Q_{CR} = V \times \left(\frac{P+0.1}{0.1} \right) \times 10^{-3} \dots(1)$$

$$Q_{CP} = a \times \ell \times \frac{P}{0.1} \times 10^{-6} \dots(2)$$

Q_{CR} = Amount of air consumption of rotary actuator [ℓ (ANR)]

Q_{CP} = Amount of air consumption of tube or piping [ℓ (ANR)]

V = Inner volume of the rotary table [cm³]

P = Operating pressure [MPa]

ℓ = Length of piping [mm]

a = Inner sectional area of piping [mm²]

Internal volume changes depending on the rotating direction (refer to the figure shown in the lower right). Because of this, to obtain the total air consumption, first calculate the air consumption of each stroke respectively by using formula (1), then add up each result.

Air in the tubing is only consumed when the table rotates from end to centre. The air consumption in the tubing can be obtained by using formula (2).

The internal volume for each rotating direction and the air consumption at each operating pressure calculated using formula (1) are shown in the table below.

To select a compressor, it is important to select one that has plenty of margin to accommodate the total air volume that is consumed by the pneumatic actuators that are located downstream. The total air consumption volume is affected by the leakage in the tube, the consumption in the drain valves and pilot valves, as well as by the reduction in air volume due to reduced temperature.

Formula

$$Q_{C2} = Q_c \times n \times \text{No. of actuators} \times \text{Margin rate}$$

Q_{C2} = Amount of exhaust air from a compressor [ℓ/min (ANR)]

n = Actuator oscillations per minute

Internal Cross Section of Tubing and Steel Piping

Nominal	O.D. (mm)	I.D. (mm)	Internal cross section a (mm ²)
T□0425	4	2.5	4.9
T□0604	6	4	12.6
TU 0805	8	5	19.6
T□0806	8	6	28.3
1/8B	—	6.5	33.2
T□1075	10	7.5	44.2
TU 1208	12	8	50.3
T□1209	12	9	63.6
1/4B	—	9.2	66.5
TS 1612	16	12	113
3/8B	—	12.7	127
T□1613	16	13	133
1/2B	—	16.1	204
3/4B	—	21.6	366
1B	—	27.6	598

[Calculation example]

Size: 10 Operating pressure: 0.5 MPa Inner sectional area of piping: 12.6 mm²

Length of piping: 1000mm Stroke: Centre → Counterclockwise → Centre → Clockwise → Centre

Total air consumption, Q_1 , is obtained by adding up the air consumption of each stroke, which is shown in the table below.

$$Q_1 = 0.019 + 0.040 + 0.019 + 0.040 = 0.118 \ell \text{ (ANR)}$$

Air consumed in the tubing is calculated using formula (2), as shown below.

$$Q_2 = 12.6 \times 1000 \times \frac{0.5}{0.1} \times 10^{-6} = 0.063 \ell \text{ (ANR)}$$

An entire stroke includes two rotations from end to centre where the air is consumed. Thus, the total air consumption Q of the rotary table and tubing is obtained as shown below.

$$Q = Q_1 + Q_2 \times 2 = 0.244 \ell \text{ (ANR)}$$

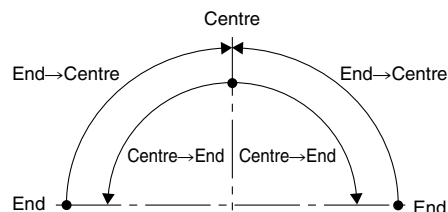

Air Consumption

Air consumption of rotary table: Q_{CR} ℓ (ANR)

Size	Operating direction	Rotation	Inner volume (cm ³)	Operating pressure (MPa)								
				0.2	0.3	0.4	0.5	0.6	0.7	0.8	0.9	1.0
10	End→Centre	90°	6.69	0.020	0.027	0.033	0.040	0.047	0.054	0.060	0.067	0.074
	Centre→End		3.11	0.009	0.012	0.016	0.019	0.022	0.025	0.028	0.031	0.034
20	End→Centre		13.2	0.040	0.053	0.066	0.079	0.093	0.106	0.119	0.132	0.145
	Centre→End		6.40	0.019	0.026	0.032	0.038	0.045	0.051	0.058	0.064	0.070
30	End→Centre		20.0	0.060	0.080	0.100	0.120	0.140	0.160	0.180	0.200	0.220
	Centre→End		9.52	0.029	0.038	0.048	0.057	0.067	0.076	0.086	0.095	0.105
50	End→Centre		32.6	0.098	0.130	0.163	0.195	0.228	0.261	0.293	0.326	0.358
	Centre→End		16.2	0.049	0.065	0.081	0.097	0.113	0.130	0.146	0.162	0.178

3-Position Rotary Table

Series MSZ

Size : 10, 20, 30, 50

How to Order

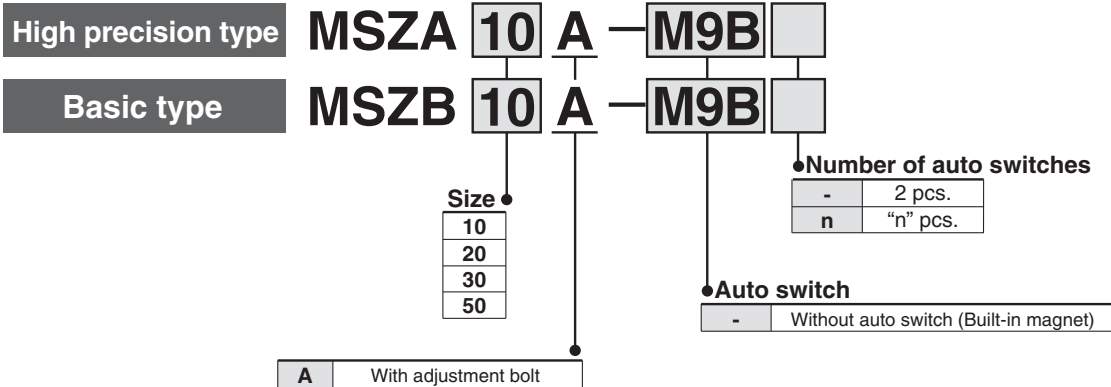

Applicable Auto Switch/Refer to pages 7 to 11 for detailed auto switch specification.

Type	Special function	Electrical entry	Indicator light	Wiring (Output)	Load voltage			Auto switch model		Lead wire length (m)*			Applicable load				
					DC	AC	Perpendicular	In-line	0.5 (Nil)	3 (L)	5 (Z)						
Reed switch	—	Grommet	No	2-wire	24 V	5 V, 12 V	100 V or less	A90V	A90	●	●	—	Relay, PLC				
			Yes	3-wire (NPN equiv.)	—	5V	—	A96V	A96	●	●	—	IC circuit				
				2-wire	24 V	12 V	100 V	A93V	A93	●	●	—	—	Relay, PLC			
Solid state switch	—	Grommet	Yes	3-wire (NPN)	24 V	5 V, 12 V	—	M9NV	M9N	●	●	○	IC circuit				
				3-wire (PNP)				M9PV	M9P	●	●	○					
				2-wire				M9BV	M9B	●	●	○		—			
				Diagnostic indication (2-colour display)				3-wire (NPN)	5 V, 12 V	—	M9NWV	M9NW	●	●	○	IC circuit	
											3-wire (PNP)	M9PWV	M9PW	●	●		○
											2-wire	M9BWV	M9BW	●	●		○
				Improved water resistance (2-colour display)				—	—	—	—	—	—	—	—	●	○
—	—	—	—	—	—	—	—	—	—	—	—						
—	—	—	—	—	—	—	—	—	—	—	—						

** Although it is possible to attach a water resistant auto switch, this is not a water-resistant-type rotary table.

* Lead wire length symbols: 0.5 m Nil (Example) M9N
 3 m L (Example) M9NL
 5 m Z (Example) M9NZ

* Auto switches marked with a "○" symbol are produced upon receipt of orders.

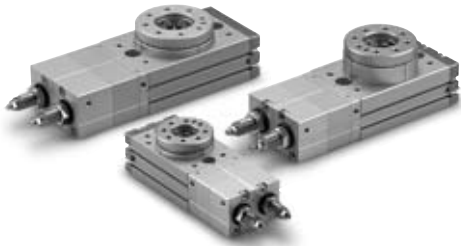

Specifications

Size	10	20	30	50
Fluid	Air (non-lube)			
Maximum operating pressure	1MPa			
Minimum operating pressure	0.2 MPa			
Ambient and fluid temperature	0 to 60°C (with no freezing)			
Cushion	None			
Rotation angle adjustment range	0 to 190°			
Centre position adjustment range	±10°			
Port size	M5			

Allowable Kinetic Energy and Rotation Time Adjustment Range

Size	Allowable kinetic energy (mJ)	Rotation time adjustment range for stable operation (s/90°)
10	7	0.2 to 1.0
20	25	
30	48	
50	81	

If a kinetic energy exceeding the allowable value is applied to the product, it may be damaged and become unusable. Care should be taken in designing, adjusting and operating the system so that the kinetic energy will not exceed the allowable values.

Weight

Size	Unit: g			
	10	20	30	50
Basic type	730	1350	1730	2660
High precision type	760	1450	1850	2820

Note) Excluding the weight of the auto switches.

Piping and speed control

- 1) A single 3-position pressure centre solenoid valve or two 3-port solenoid valves can be used. (Refer to Figures 1 or 2.)
- 2) A meter-out type speed controller is used for ports **A** and **B** and a meter-in type speed controller is used for ports **C** and **D**. (Figures 1 and 2 show the state at which pressure is applied to ports **B** and **D**.)

Figure 1 3-position pressure centre solenoid valve: 1 pc.

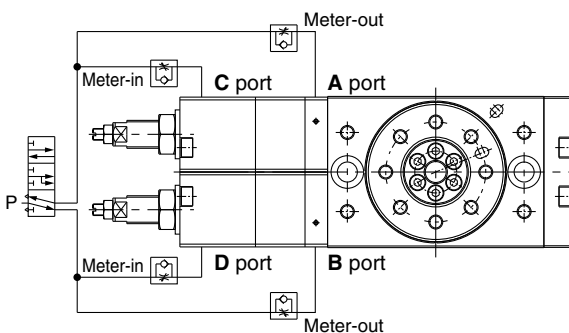
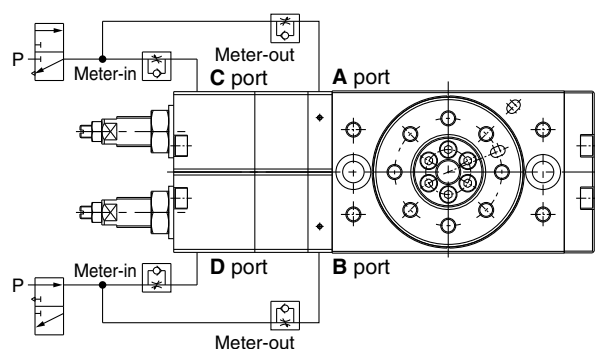

Figure 2 3-position solenoid valve: 2 pcs.



* The table return position under the power-off state changes depending on the solenoid valve type. Please refer to back page 6 for details.

- 3) Figure 3 shows the operational direction and Table 1 shows the pressure port and active speed controller for each operation.

Figure 3 Operational directions

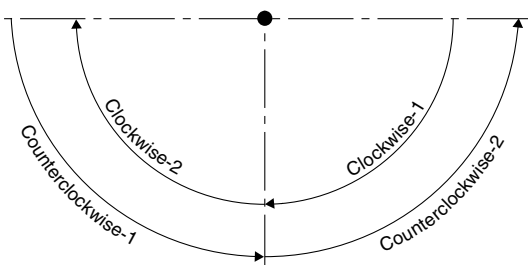

Table 1 Pressure port and active speed controller

Operating	Pressure port		Speed controller
	A, C	B, D	
Clockwise-1	●	●	C port
Clockwise-2	●	—	B port
Counterclockwise-1	●	●	D port
Counterclockwise-2	—	●	A port

Angle Adjustment

1) Stop positions are adjusted with the adjusting bolts shown in Figure 4.

- ① Adjusting bolts "a" and "b" are used for adjusting the rotation ends. Adjusting bolts "c" and "d" are used for adjusting the centre position.
- ② Figure 5 shows the angle ranges that can be adjusted with each adjusting bolt.

2) Angle adjustment

Supply air when adjusting the angle (a low pressure of approx. 0.2 MPa is recommended).

- ① First adjust both rotation end positions.
 - Apply pressure to ports A and C and to adjust adjusting bolt "b".
 - Apply pressure to ports B and D and to adjust adjusting bolt "a".
 - Lock the bolts with the fixing nuts after adjustment.
- ② Next, apply pressure to ports A to D to adjust the centre position.
 - Loosen the fixing nuts for adjusting bolts "c" and "d".
 - Tighten adjusting bolts "c" and "d" until they are almost hidden completely behind the fixing nuts (the table can be rotated manually).
 - Follow the appropriate procedure (R or L) shown in Table 2.

Figure 4 Adjusting bolt position

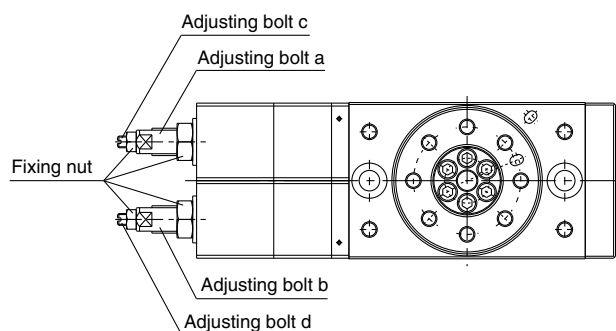

Figure 5 Angle adjustment Range

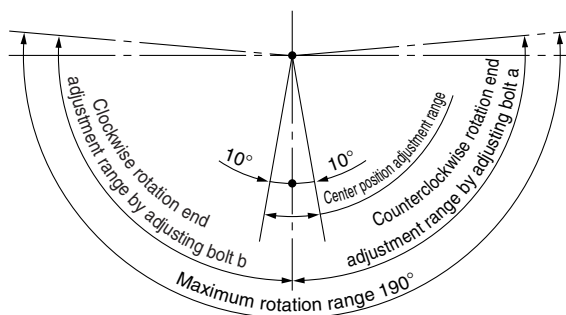

Table 2 Centre position adjustment

	R: Clockwise adjustment	L: Counterclockwise adjustment
1	Manually rotate the table counterclockwise until resistance is felt.	Manually rotate the table clockwise until resistance is felt.
2	Rotate the table clockwise when adjusting bolt "d" is loosened. Set it to the desired position.	Rotate the table counterclockwise when adjusting bolt "c" is loosened. Set it to the desired position.
3	Loosen adjusting bolt "c" until resistance is felt. (Make sure that there is no rotation backlash in the table.)	Loosen adjusting bolt "d" until resistance is felt. (Make sure that there is no rotation backlash in the table.)
4	Tighten both adjusting bolts "c" and "d" by approx. 45°. Note 1)	Tighten both adjusting bolts "c" and "d" by approx. 45°. Note 1)
5	Lock adjusting bolts "c" and "d" with fixing nuts. Note 2)	Lock adjusting bolts "c" and "d" with fixing nuts. Note 2)

Note 1) Since the position of the adjusting bolt can shift with the changing of screw clearance when tightening the fixing nuts.

Note 2) If the table has a rotation backlash after tightening the nut, readjust it.

Adjusting angle per rotation of angle adjusting screw

size	Adjusting bolt a, b (End position adjustment)	Adjusting bolt c, d (Centre position adjustment)
10	10.2°	5.1°
20	9.0°	3.6°
30	8.2°	3.3°
50	8.2°	4.1°

A piping, speed control, and angle adjustment manual is attached to the product.

Series MSZ

Construction

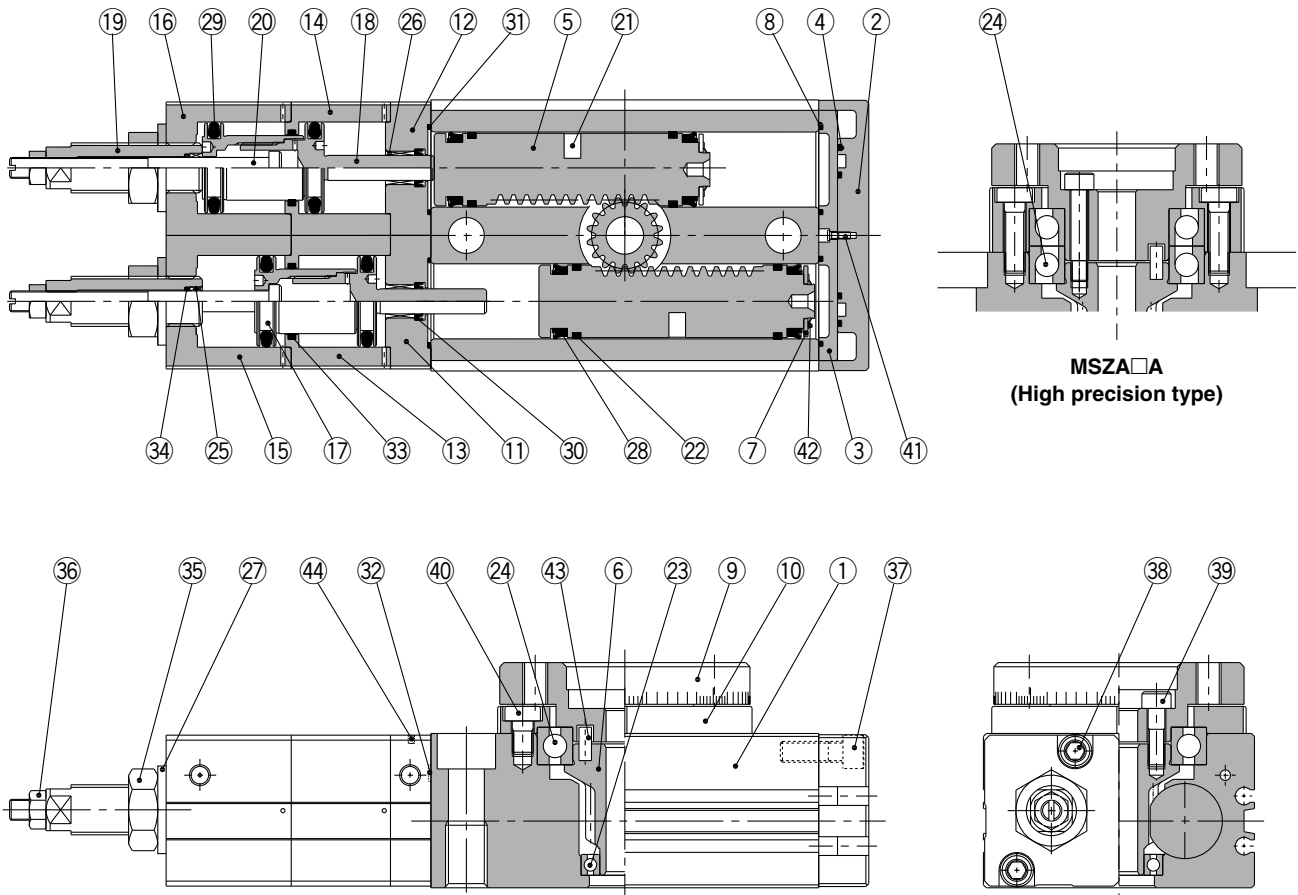

Component Parts

No.	Description	Material
1	Body	Aluminium alloy
2	Cover	Aluminium alloy
3	Plate	Aluminium alloy
4	Seal	NBR
5	Piston	Stainless steel
6	Pinion	Chrome molybdenum steel
7	Seal retainer	Aluminium alloy
8	Gasket (for cover)	NBR
9	Table	Aluminium alloy
10	Bearing retainer	Aluminium alloy
11	End cover (A)	Aluminium alloy
12	End cover (B)	Aluminium alloy
13	Cylinder tube (A)	Aluminium alloy
14	Cylinder tube (B)	Aluminium alloy
15	Tube cover (A)	Aluminium alloy
16	Tube cover (B)	Aluminium alloy
17	Sub piston (R)	Carbon steel
18	Sub piston (F)	Carbon steel
19	Adjustment bolt (R)	Carbon steel
20	Adjustment bolt (F)	Carbon steel
21	Magnet	Magnetic material
22	Wear ring	Resin
23	Deep groove ball bearing	Bearing steel

No.	Description	Material
24	Basic type	Deep groove ball bearing
	High precision type	Angular contact ball bearing
25	Bushing	SPCC
26	Bushing	SPCC
27	Seal washer	NBR
28	Piston seal	NBR
29	Piston seal	NBR
30	Rod seal	NBR
31	Gasket	NBR
32	O-ring	NBR
33	O-ring	NBR
34	O-ring	NBR
35	Compact hexagon nut	Steel wire
36	Hexagon nut	Steel wire
37	Hexagon socket head set bolt	Stainless steel
38	Hexagon socket head set bolt	Stainless steel
39	Hexagon socket head set bolt	Stainless steel
40	Size: 10	Round head phillips screw
	Size: 20, 30, 50	Low head cap screw
41	Round head phillips screw No.0	Steel wire
42	CS type snap ring	Spring steel
43	Parallel pin	Carbon steel
44	Steel ball	Stainless steel

Dimensions

Basic type/MSZB□A

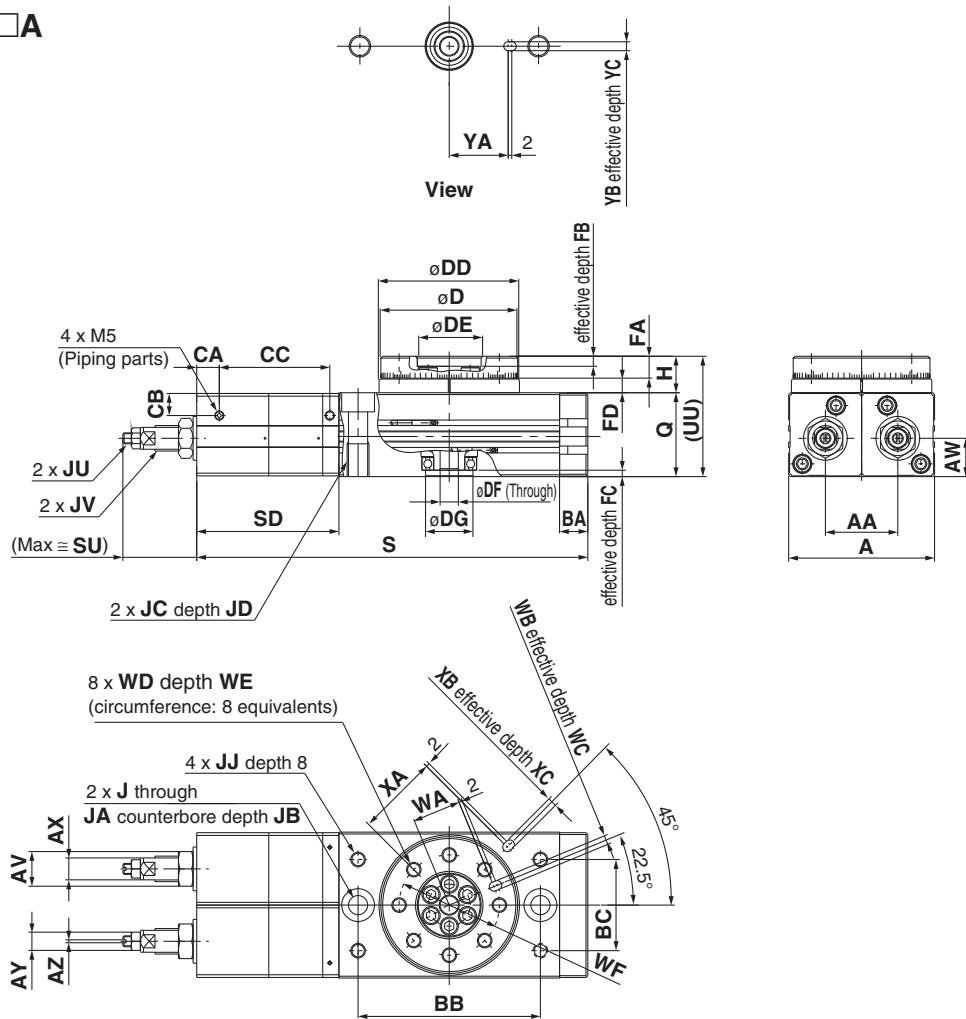

High precision type/MSZA□A

Size	DH	DI	DJ	DK	DL	FE	HA	UV
10	45h8	46h8	20H8	6	15H8	10	18.5	52.5
20	60h8	61h8	28H8	9	17H8	15.5	26	63
30	65h8	67h8	32H8	12	22H8	16.5	27	67
50	75h8	77h8	35H8	13	26H8	17.5	30	76

The position table shows the counterclockwise end when adjusted the rotation angle to 180°.

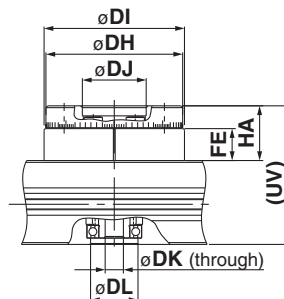

Size	AA	A	AV	AW	AX	AY	AZ	BA	BB	BC	CA	CB	CC	D	DD	DE	DF	DG	FA	FB	FC	FD	H	J	JA	JB
10	24.7	50	14	17	8	7	1	9.5	60	27	7	7	38	45h9	46h9	20H9	6	15H9	8	4	3	4.5	13	6.8	11	6.5
20	32.4	65	17	18.5	10	8	1.2	12	76	34	8.1	10	50.4	60h9	61h9	28H9	9	17H9	10	6	2.5	6.5	17	8.6	14	8.5
30	34.7	70	17	18.5	10	8	1.2	12	84	37	10.5	10.5	53.5	65h9	67h9	32H9	12	22H9	10	4.5	3	6.5	17	8.6	14	8.5
50	39.7	80	19	21	12	10	1.6	15.5	100	50	12.4	12.5	60.6	75h9	77h9	35H9	13	26H9	12	5	3	7.5	20	10.5	18	10.5

Size	JC	JD	JJ	JU	JV	Q	S	SD	SU	UU	WA	WB	WC	WD	WE	WF	XA	XB	XC	YA	YB	YC
10	M8 x 1.25	12	M5	M4 x 0.5	M10 x 1	34	132.5	50	27.3	47	15	3H9	3.5	M5	8	32	27	3H9	3.5	19	3H9	3.5
20	M10 x 1.5	15	M6	M5 x 0.5	M12 x 1.25	37	168.5	63.5	39	54	20.5	4H9	4.5	M6	10	43	36	4H9	4.5	24	4H9	4.5
30	M10 x 1.5	15	M6	M5 x 0.5	M12 x 1.25	40	184	69	36.4	57	23	4H9	4.5	M6	10	48	39	4H9	4.5	28	4H9	4.5
50	M12 x 1.75	18	M8	M6 x 0.75	M14 x 1.5	46	214.5	78	42.4	66	26.5	5H9	5.5	M8	12	55	45	5H9	5.5	33	5H9	5.5

Proper Auto Switch Mounting Position

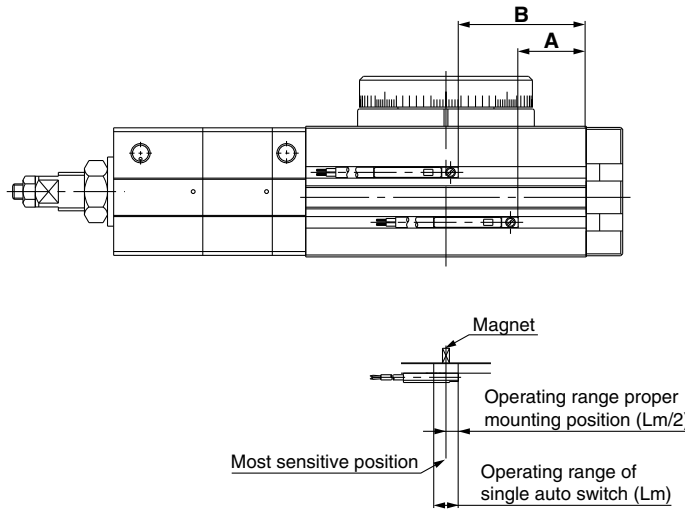

Size	Rotation	Reed switch				Solid state switch							
		D-A9□, D-A9□V		D-M9□W, D-M9□WV, D-M9BAL				D-M9□, D-M9□V					
		A	B	Operating angle θ m	Hysteresis angle	A	B	Operating angle θ m	Hysteresis angle	A	B	Operating angle θ m	Hysteresis angle
10	190°	27	45	90°	10°	31	49	90°	10°	31	49	60°	10°
20	190°	35	62	80°	10°	39	66	80°	10°	39	66	50°	10°
30	190°	39	68	65°	10°	43	72	65°	10°	43	72	50°	10°
50	190°	49	83	50°	10°	53	87	50°	10°	53	87	40°	10°

Operating angle θ m: Value of the operating range Lm of a single auto switch when converted to an axial rotation angle.
 Hysteresis angle: Value of the auto switch hysteresis when converted to an angle.

Detection of the Center Position

The appropriate mounting position of the centre position detection switch is between dimensions A and B, as shown above. However, since the auto switch turns on in the range of the operating angle (θ m), when one auto switch is used for detecting the centre position, the switch turns on long before reaching the centre position, as shown in the left figure below. To avoid this, use two switches (as shown in the right figure below) so that the rotation may be detected from both the clockwise rotation end to the centre position and from the counterclockwise rotation end to the centre position.

Centre position detecting switch: 1 pc.

Centre position detecting switch: 2 pcs.

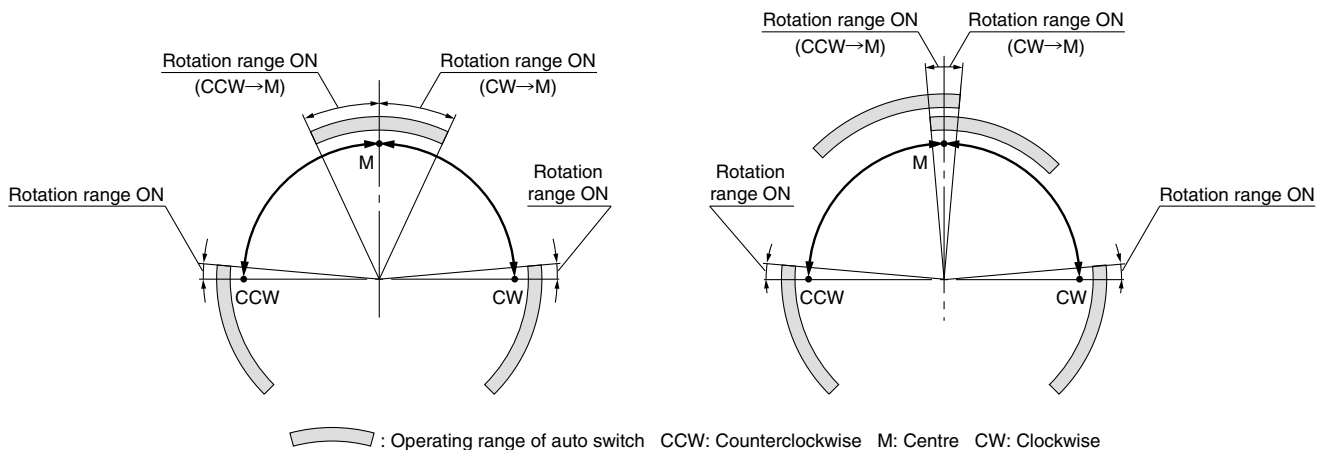

Series MSZ

Auto Switch Specifications

Auto Switch Common Specifications

Type	Reed switch	Solid state switch
Leakage current	None	3-wire: 100 μ A or less, 2-wire: 0.8 mA or less
Operating time	1.2 ms	1 ms or less
Impact resistance	300 m/s ²	1000 m/s ²
Insulation resistance	50 M Ω or more at 500 V DC Mega (between lead wire and case)	
Withstand voltage	1000 V AC for 1 min. (between lead wire and case)	1000 V AC for 1 min. (between lead wire and case)
Ambient temperature	-10 to 60°C	
Enclosure	IEC529 standard IP67, watertight (JIS C 0920)	

Lead Wire Length

Lead wire length indication

(Example) D-M9P **L**

Lead wire length

-	0.5 m
L	3 m
Z	5 m

- Note 1) Lead wire length Z: 5 m applicable auto switches
Solid state switch: All types are produced upon receipt of order.
Note 2) For solid state switches with flexible wire specification, add "-61" at the end of the lead wire length.

(Example) D-M9PVL- **61**

Flexible specification

Contact Protection Box/CD-P11, CD-P12

<Applicable switch type>

D-A9 and D-A9□V, type switches do not have internal contact protection circuits.

- (1) The operated load is an induction load.
- (2) The length of wiring to the load is 5 m or more.
- (3) The load voltage is 100 VAC.

A contact protection box should be used in any of the above situations.
Otherwise the lifetime of the contact may be shortened.

Specifications

Part No.	CD-P11		CD-P12
Load voltage	100 V AC	200 V AC	24 V DC
Max. load current	25 mA	12.5 mA	50 mA

* Lead wire length — Switch connection side: 0.5 m
Load connection side: 0.5 m



Internal Circuit

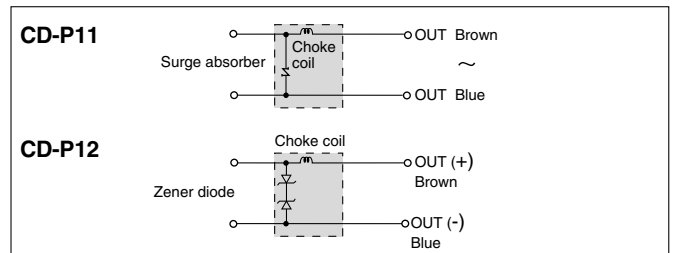

Dimensions

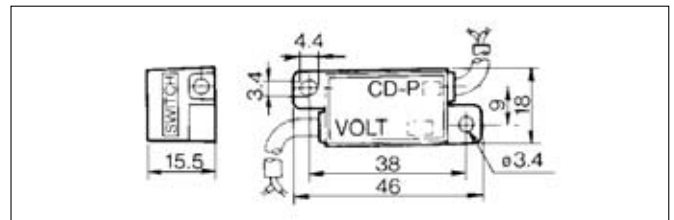

Contact Protection Box/Connection

To connect a switch unit to a contact protection box, connect the lead wire from the side of the contact protection box marked SWITCH to the lead wire coming out of the switch unit. The switch unit should be kept as close as possible to the contact protection box with a lead wire that is no more than 1 metre in length.

Auto Switch Connections and Examples

Basic Wiring

Solid state 3-wire, NPN

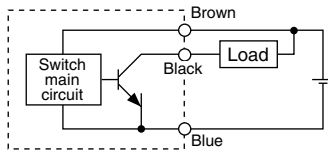

Solid state 3-wire, PNP

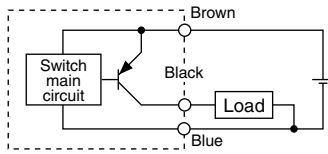

2-wire (Solid state)

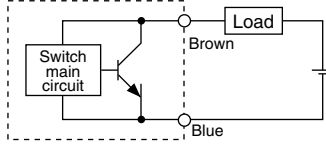

2-wire (Reed)

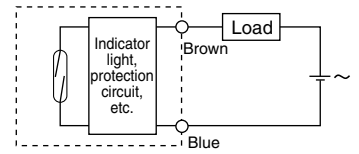

(When power supply for switch and load are separate.)

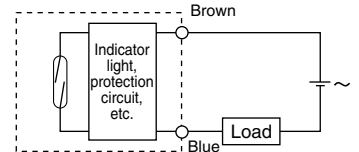
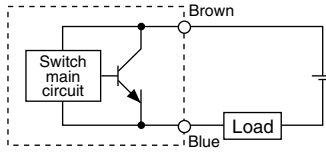
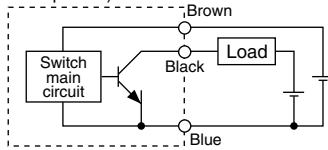

Examples of Connection to PLC

Sink input specifications

3-wire, NPN

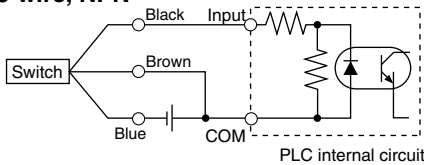

Source input specifications

3-wire, PNP

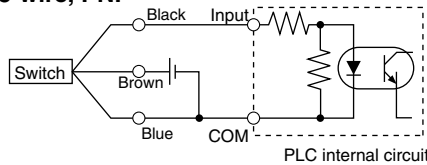

Connect according to the applicable PLC input specifications, as the connection method will vary depending on the PLC input specifications.

2-wire

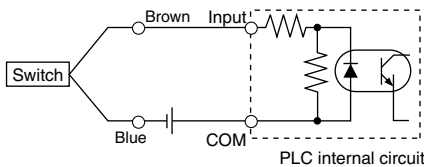

2-wire

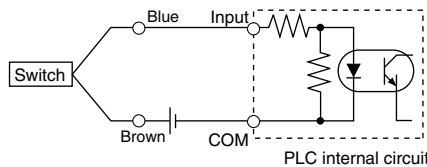

Connection Examples for AND (Series) and OR (Parallel)

3-wire

AND connection for NPN output (using relays)

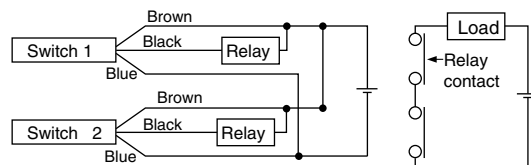

AND connection for NPN output (performed with switches only)

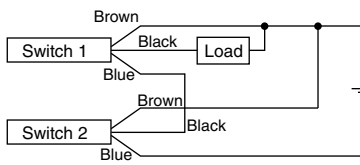

OR connection for NPN output

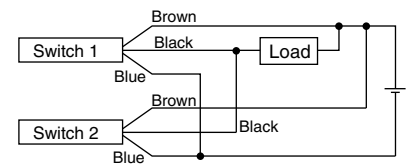

The indicator lights will light up when both switches are turned ON.

2-wire with 2 switches AND connection

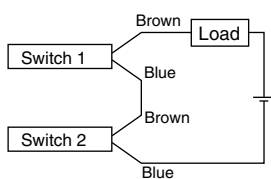

When two switches are connected in series, a load may malfunction because the load voltage will decline when in the ON state. The indicator lights will light up if both of the switches are in the ON state.

2-wire with 2 switches OR connection

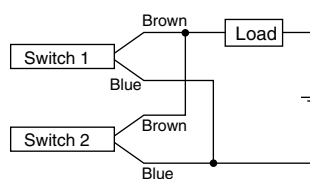

(Solid state) When two switches are connected in parallel, malfunction may occur because the load voltage will increase when in the OFF state.

(Reed) Because there is no current leakage, the load voltage will not increase when turned OFF. However, depending on the number of switches in the ON state, the indicator lights may sometimes get dark or not light up, because of dispersion and reduction of the current flowing to the switches.

$$\begin{aligned} \text{Load voltage at ON} &= \text{Power supply voltage} - \text{Residual voltage} \times 2 \text{ pcs.} \\ &= 24 \text{ V} - 4 \text{ V} \times 2 \text{ pcs.} \\ &= 16 \text{ V} \end{aligned}$$

Example: Power supply voltage is 24 V DC
Voltage decline in switch is 4 V

$$\begin{aligned} \text{Load voltage at OFF} &= \text{Leakage current} \times 2 \text{ pcs.} \times \text{Load impedance} \\ &= 1 \text{ mA} \times 2 \text{ pcs.} \times 3 \text{ k}\Omega \\ &= 6 \text{ V} \end{aligned}$$

Example: Load impedance is 3 kΩ
Leakage current from switch is 1 mA

Reed Switch: Direct Mounting Style D-A90(V)/D-A93(V)/D-A96(V)



For details about certified products conforming to international standards, visit us at www.smcworld.com.

Auto Switch Specifications

PLC: Programmable Logic Controller

Grommet Electrical entry: In-line



Caution

Operating Precautions

Fix the switch with the existing screw installed on the switch body. The switch may be damaged if a screw other than the one supplied, is used.

Auto Switch Internal Circuit

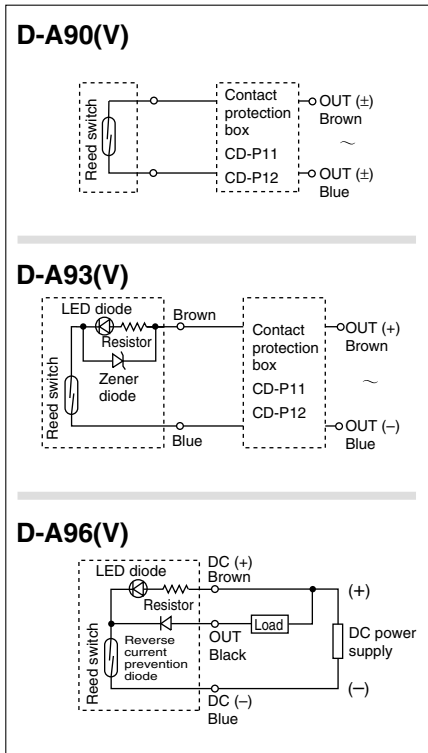

- Note) (1) In a case where the operation load is an inductive load.
(2) In a case where the wiring load is greater than 5 m.
(3) In a case where the load voltage is 100 VAC.

Please use the auto switch with a contact protection box any of the above mentioned cases. (For details about the contact protection box, refer to page 7.)

D-A90/D-A90V (Without indicator light)			
Auto switch part no.	D-A90/D-A90V		
Applicable load	IC circuit, Relay, PLC		
Load voltage	24 V AC/DC or less	48 V AC/DC or less	100 V AC/DC or less
Maximum load current	50 mA	40 mA	20 mA
Contact protection circuit	None		
Internal resistance	1 Ω or less (including lead wire length of 3 m)		
D-A93/D-A93V/D-A96/D-A96V (With indicator light)			
Auto switch part no.	D-A93/D-A93V		D-A96/D-A96V
Applicable load	Relay, PLC		IC circuit
Load voltage	24 V DC	100 V AC	4 to 8 V DC
Load current range and max. load current	Note 3) 5 to 40 mA	5 to 20 mA	20 mA
Contact protection circuit	None		
Internal voltage drop	D-A93 — 2.4 V or less (to 20 mA)/3 V or less (to 40 mA) D-A93 V — 2.7 V or less		0.8 V or less
Indicator light	Red LED lights when ON		

Lead wires

D-A90(V)/D-A93(V) — Oilproof vinyl heavy-duty cord: $\phi 2.7$, 0.18 mm² x 2 cores (Brown, Blue), 0.5 m
D-A96(V) — Oilproof vinyl heavy-duty cord: $\phi 2.7$, 0.15 mm² x 3 cores (Brown, Black, Blue), 0.5 m

Note 1) Refer to page 7 for reed switch common specifications.

Note 2) Refer to page 7 for lead wire lengths.

Weight

Unit: g

Model	D-A90	D-A90V	D-A93	D-A93V	D-A96	D-A96V
Lead wire length: 0.5 m	6	6	6	6	8	8
Lead wire length: 3 m	30	30	30	30	41	41

Dimensions

Unit: mm

D-A90/D-A93/D-A96

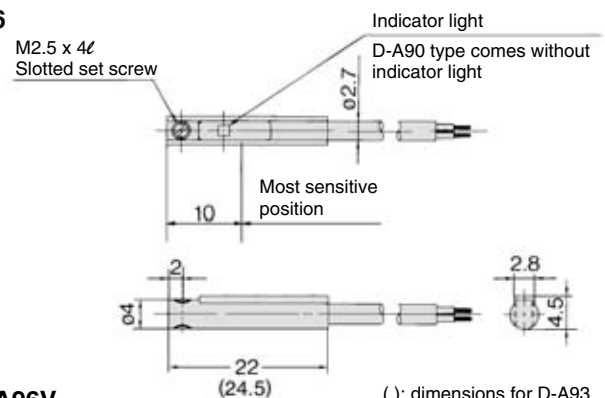

(): dimensions for D-A93.

D-A90V/D-A93V/D-A96V

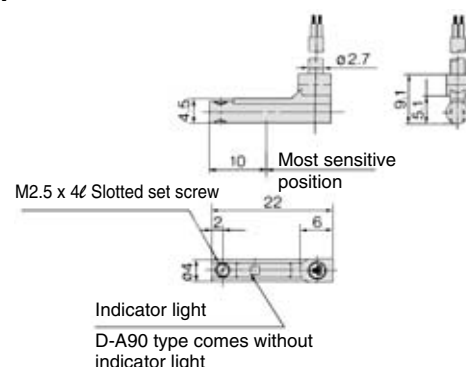

Solid State Switch: Direct Mounting Style D-M9N(V)/D-M9P(V)/D-M9B(V)



For details about certified products conforming to international standards, visit us at www.smcworld.com.

Auto Switch Specifications

PLC: Programmable Logic Controller

D-M9□, D-M9□V (With indicator light)						
Auto switch part no.	D-M9N	D-M9NV	D-M9P	D-M9PV	D-M9B	D-M9BV
Electrical entry direction	In-line	Perpendicular	In-line	Perpendicular	In-line	Perpendicular
Wiring type	3-wire			2-wire		
Output type	NPN		PNP		—	
Applicable load	IC circuit, Relay, PLC				24 V DC relay, PLC	
Power supply voltage	5, 12, 24 V DC (4.5 to 28 V)					—
Current consumption	10 mA or less					—
Load voltage	28 V DC or less		—		24 V DC (10 to 28 V DC)	
Load current	40 mA or less				2.5 to 40 mA	
Internal voltage drop	0.8 V or less				4 V or less	
Leakage current	100 μA or less at 24 V DC				0.8 mA or less	
Indicator light	Red LED lights when ON.					

Lead wires

- Oilproof vinyl heavy-duty cord: $\phi 2.7 \times 3.2$ ellipse, 0.15 mm²,
- D-M9B(V) 0.15 mm² x 2 cores
- D-M9N(V), D-M9P(V) 0.15 mm² x 3 cores

Note 1) Refer to page 7 for auto switch common specifications.

Note 2) Refer to page 7 for lead wire lengths.

Grommet

- 2-wire load current is reduced (2.5 to 40 mA)
- Lead-free
- UL certified (style 2844) lead cable is used.



Caution

Operating Precautions

Fix the switch with the existing screw installed on the switch body. The switch may be damaged if a screw other than the one supplied, is used.

Auto Switch Internal Circuit

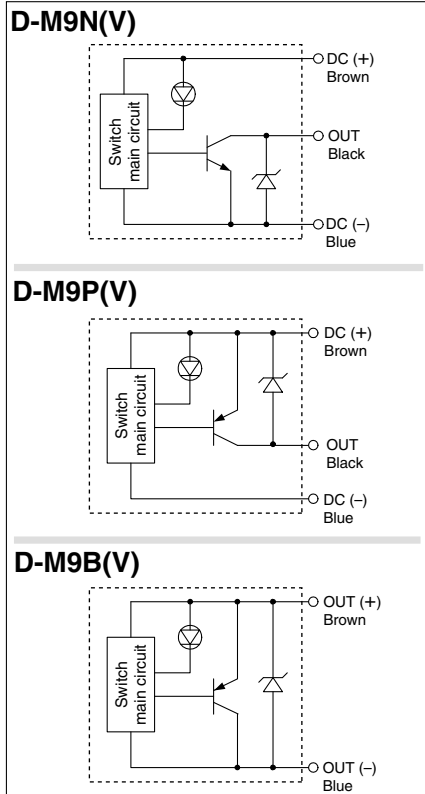

Weight

Unit: g

Auto switch part no.	D-M9N(V)	D-M9P(V)	D-M9B(V)
Lead wire length (m)	0.5	8	7
	3	41	38
	5	68	63

Dimensions

Unit: mm

D-M9□

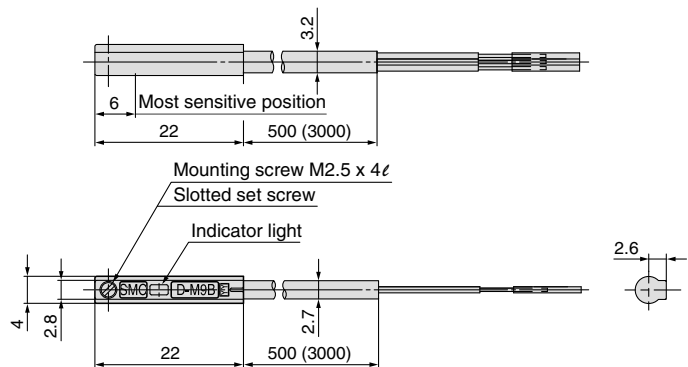

D-M9□V

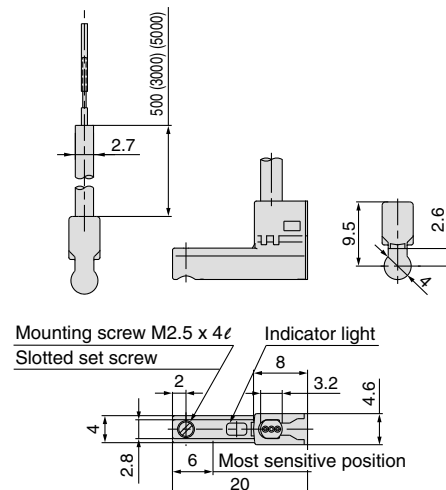

2-colour Indication Type, Solid State Switch: Direct Mounting Style

D-M9NW(V)/D-M9PW(V)/D-M9BW(V)

Grommet



Auto Switch Specifications



For details about certified products conforming to international standards, visit us at www.smcworld.com.

PLC: Programmable Logic Controller

D-M9□W/D-M9□WV (With indicator light)						
Auto switch part no.	D-M9NW	D-M9NWV	D-M9PW	D-M9PWV	D-M9BW	D-M9BWV
Electrical entry direction	In-line	Perpendicular	In-line	Perpendicular	In-line	Perpendicular
Wiring type	3-wire				2-wire	
Output type	NPN		PNP		—	
Applicable load	IC circuit, Relay, PLC				24 V DC relay, PLC	
Power supply voltage	5, 12, 24 V DC (4.5 to 28 VDC)				—	
Current consumption	10 mA or less				—	
Load voltage	28 V DC or less		—		24 V DC (10 to 28 V DC)	
Load current	40 mA or less		80 mA or less		5 to 40 mA	
Internal voltage drop	1.5 V or less (0.8 V or less at 10 mA load current)		0.8 V or less		4 V or less	
Leakage current	100 μA or less at 24 V DC				0.8 mA or less	
Indicator light	Operating position Red LED lights up Optimum operating position Green LED lights up					

Auto Switch Internal Circuit

D-M9NW(V)

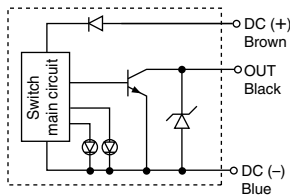

D-M9PW(V)

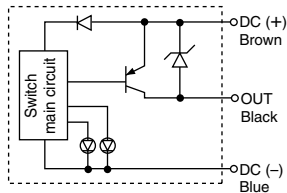

D-M9BW(V)

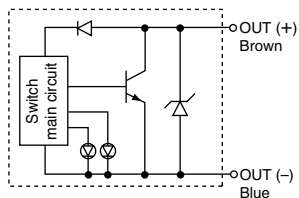

Indicator light/Display method

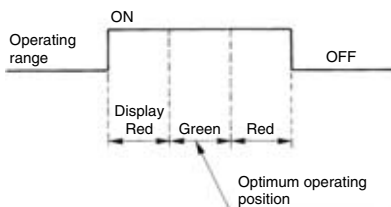

Lead wires

Oilproof vinyl heavy-duty cord: $\phi 2.7$, 0.15 mm² x 3 cores (Brown, Black, Blue),
0.18 mm² x 2 cores (Brown, Blue), 0.5 m

Note 1) Refer to page 7 for auto switch common specifications.

Note 2) Refer to page 7 for lead wire lengths.

Weight

Unit: g

Auto switch part no.	D-M9NW(V)	D-M9PW(V)	D-M9BW(V)
Lead wire length (m)	0.5	7	7
	3	34	32
	5	56	52

Dimensions

Unit: mm

D-M9□W

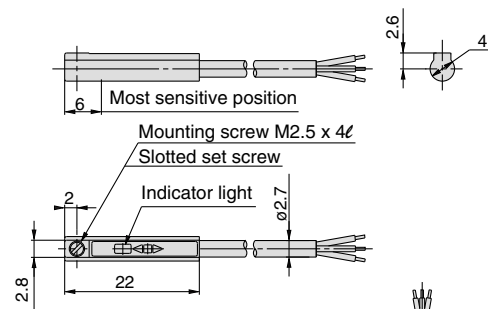

D-M9□WV

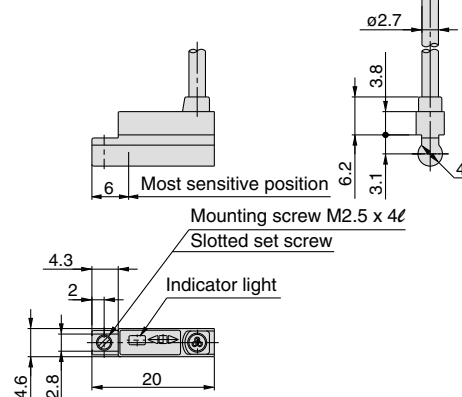





Series **MSZ**

Safety Instructions

These safety instructions are intended to prevent a hazardous situation and/or equipment damage. These instructions indicate the level of potential hazard by labels of “**Caution**”, “**Warning**” or “**Danger**”. To ensure safety, be sure to observe ISO 4414^{Note1)}, JIS B 8370^{Note2)} and other safety practices.

■Explanation of the Labels

Labels	Explanation of the labels
 Danger	In extreme conditions, there is a possible result of serious injury or loss of life.
 Warning	Operator error could result in serious injury or loss of life.
 Caution	Operator error could result in injury or equipment damage.

Note 1) ISO 4414: Pneumatic fluid power – General rules relating to systems.

Note 2) JIS B 8370: General Rules for Pneumatic Equipment

Note 3) Injury indicates light wounds, burns and electrical shocks that do not require hospitalisation or hospital visits for long-term medical treatment.

Note 4) Equipment damage refers to extensive damage to the equipment and surrounding devices.

■Selection/Handling/Applications

1. The compatibility of pneumatic equipment is the responsibility of the person who designs the pneumatic system or decides its specifications.

Since the products specified here are used in various operating conditions, their compatibility for the specific pneumatic system must be based on specifications or after analysis and/or tests to meet your specific requirements. The expected performance and safety assurance are the responsibility of the person who has determined the compatibility of the system. This person should continuously review the suitability of all item specified, referring to the latest catalogue information with a view to giving due consideration to any possibility of equipment failure when configuring a system.

2. Only trained personnel should operate pneumatically operated machinery and equipment.

Compressed air can be dangerous if handled incorrectly. Assembly, handling or repair of pneumatic systems should be performed by trained and experienced operators. (Trained operators should understand JIS B 8370 “General Rules for Pneumatic Equipment” and other safety regulations.)

3. Do not service machinery/equipment or attempt to remove components until safety is confirmed.

1. Inspection and maintenance of machinery/equipment should only be performed once measures to prevent falling or runaway of the driven objects have been confirmed.
2. When equipment is removed, confirm the safety process as mentioned above, turn off the supply pressure for this equipment, exhaust all residual compressed air and release all energy (liquid pressure, spring, condenser and gravity) in the system.
3. Before machinery/equipment is restarted, take measures to prevent shooting-out of cylinder piston rod, etc.

4. Take measures for safety and contact SMC if the product is to be used in any of the following conditions and atmosphere:

1. Conditions and environments beyond the given specifications, or if product is used outdoors or with direct sun lights.
2. Installation on equipment in conjunction with atomic energy, railway, air navigation, vehicles, medical equipment, food and beverages, recreation equipment, emergency stop circuits, clutch/brake circuit for press, or safety equipment.
3. An application which has the possibility of having negative effects on people, property, or animals, requiring special safety analysis.
4. If the products are used in an interlock circuit, prepare a double interlock style circuit with a mechanical protection function for the prevention of a breakdown. And, examine the devices periodically if they function normally or not.

■Exemption from Liability

1. SMC, its officers and employees shall be exempted from liability for any loss or damage arising out of earthquake or fire, action by a third person, accidents, customer error with or without intention, product misuse, and any other damages caused by abnormal operating conditions.

2. SMC, its officers, and its employees shall be exempted from liability for any incidental damage that is caused by the use or the inability to use this product (loss of business interests, business interruptions, etc.).

3. SMC is exempted from liability for any damages caused by operations not contained in the catalogues and/or instruction manuals, and operations outside of the specification range.

4. SMC is exempted from liability for any loss or damage whatsoever caused by malfunctions of its products when combined with other devices or software.



Series MSZ Auto Switch Precautions 1

Be sure to read before handling.

Design and Selection

Warning

1. Confirm the specifications.

Read the specifications carefully and use this product appropriately. The product may be damaged or malfunction if it is used outside the range of specifications of current load, voltage, temperature or impact. We do not guarantee any damage in any case the product is used outside of the specification range.

2. Keep wiring as short as possible.

<Reed switches>

As the length of the wiring to a load gets longer, the rush current at switching ON becomes greater, and this may shorten the products life. (The switch will stay ON all the time.)

- 1) For an auto switch without a contact protection circuit, use a contact protection box when the wire length is 5 m or longer.
- 2) Even if an auto switch has a built-in contact protection circuit, when the wiring is more than 30 m long, it is not able to adequately absorb the rush current and its life may be reduced. It is again necessary to connect a contact protection box in order to extend its life. Please contact SMC in this case.

<Solid state switch>

- 3) Although wire length should not affect switch function, use a wire that is 100 m or shorter.

3. Do not use a load that generates surge voltage. If a surge voltage is generated, possibly resulting in the shortening of product life.

<Reed switch>

If driving a load such as a relay that generates a surge voltage, use a switch with a built-in contact protection circuit or use a contact protection box.

<Solid state switch>

Although a zener diode for surge protection is connected at the output side of a solid state auto switch, damage may still occur if a surge is applied repeatedly. When directly driving a load which generates surge, such as a relay or solenoid valve, use a type of switch with a built-in surge absorbing element.

4. Cautions for use in an interlock circuit

When an auto switch is used for an interlock signal requiring high reliability, devise a double interlock system to safeguard against malfunctions by providing a mechanical protection function, or by also using another switch (sensor) together with the auto switch. Also perform periodic inspection and confirm proper operation.

5. Do not disassemble the product or make any modifications, including additional machining.

Caution

1. Take precautions when multiple cylinders are used close together.

When two or more auto switch actuator are lined up in close proximity to each other, magnetic field interference may cause the switches to malfunction. Maintain a minimum separation of 40 mm. (When the allowable interval is specified for each series, use the indicated value.)

2. Take precautions for the internal voltage drop of the switch.

<Reed switch>

- 1) Switches with an indicator light (Except D-A96/A96V)

• If auto switches are connected in series as shown below, take note that there will be a large voltage drop because of internal resistance in the light emitting diodes. (Refer to internal voltage drop in the auto switch specifications.)

[The voltage drop will be "n" times larger when "n" auto switches are connected.]

Even though an auto switch operates normally, the load may not operate.



• Similarly, when operating below a specified voltage, it is possible that the load may be ineffective even though the auto switch function is normal. Therefore, the formula below should be satisfied after confirming the minimum operating voltage of the load.

$$\text{Supply voltage} - \text{Internal voltage drop of switch} > \text{Minimum operating voltage of load}$$

- 2) If the internal resistance of a light emitting diode causes a problem, select a switch without an indicator for light (MODEL D-A90/A90V)

<Solid state switch>

- 3) Generally, the internal voltage drop will be great with a 2-wire solid state auto switch. Also, note that a 12 V DC relay is not applicable.

3. Pay attention to leakage current.

<Solid state switch>

With a 2-wire solid state auto switch, current (leakage current) flows to the load to operate the internal circuit even when in the OFF state.

$$\text{Current to operate load (OFF condition)} > \text{Leakage current}$$

If the condition given in the above formula is not met, it will not reset correctly (stays ON). Use a 3-wire switch if this specification cannot be satisfied.

Moreover, leakage current flow to the load will be "n" times larger when "n" auto switches are connected in parallel.

4. Ensure sufficient clearance for maintenance activities.

When designing an application, be sure to allow sufficient clearance for maintenance and inspections.



Series MSZ Auto Switch Precautions 2

Be sure to read before handling.

Mounting and Adjustment

Warning

1. Instruction manual.

Install the products and operate them only after reading the instruction manual carefully and understanding its contents. Also keep the manual where it can be referred to as necessary.

2. Do not drop or bump.

Do not drop, bump or apply excessive impacts (300m/s² or greater for reed switches and 1000m/s² or greater for solid state switches) while handling.

Although the body of the switch may not be damaged, the inside of the switch could be damaged and cause a malfunction.

3. Mount switches using the proper tightening torque.

When a switch is tightened above the torque specification, the mounting screws, or switch may be damaged. On the other hand, tightening below the torque specification may allow the switch to slip out of position. (Refer to switch mounting for each series regarding switch mounting, moving, and fastening torque, etc.)

4. Mount a switch at the centre of the operating range.

Adjust the mounting position of an auto switch so that the piston stops at the centre of the operating range (the range in which a switch is ON). (The mounting positions shown in the catalogue indicate the optimum position at the stroke end.) If mounted at the end of the operating range (around the borderline of ON and OFF), operation will be unstable.

<D-M9□>

When the D-M9 auto switch is used to replace old series auto switch, it may not activate depending on operating condition because of its shorter operating range.

Such as

- Application where the stop position of actuator may vary and exceed the operating range of the auto switch, for example, pushing, pressing, clamping operation, etc.
- Application where the auto switch is used for detecting an intermediate stop position of the actuator. (In this case the detecting time will be reduced.)

In these applications, please set the auto switch to the centre of the required detecting range.

5. Securing the space for maintenance

When installing the products, please allow access for maintenance.

Caution

1. Do not carry an actuator by the auto switch lead wires.

Never carry a cylinder by its lead wires. This may not only cause broken lead wires, but it may cause internal elements of the switch to be damaged by the stress.

2. Fix the switch with the appropriate screw installed on the switch body. If using other screws, switch may be damaged.

Wiring

Warning

1. Confirm proper insulation of wiring.

Be certain that there is no faulty wiring insulation (such as contact with other circuits, ground fault, improper insulation between terminals, etc.). Damage may occur due to excess current flow into a switch.

2. Do not wire in conjunction with power lines or high voltage lines.

Wire separately from power lines or high voltage lines, avoiding parallel wiring or wiring in the same conduit with these lines. Control circuits containing auto switches may malfunction due to noise from these lines.

Caution

1. Avoid repeatedly bending or stretching lead wires.

Broken lead wires will result from repeatedly applying bending stress or stretching force to the lead wires.

2. Be sure to connect the load before power is applied.

<2-wire type>

If the power is turned ON when an auto switch is not connected to a load, the switch will be instantly damaged because of excess current.

3. Do not allow short circuit of loads.

<Reed switch>

If the power is turned ON with a load in a short circuited condition, the switch will be instantly damaged because of excess current flow into the switch.

<Solid state switch>

D-M9□, D-M9□W(V) and all models of PNP output type switches do not have built-in short circuit protection circuits. If loads are short circuited, the switches will be instantly damaged, as in the case of reed switches.

Take special care to avoid reverse wiring with the brown [red] power supply line and the black [white] output line on 3-wire type switches.



Series MSZ Auto Switch Precautions 3

Be sure to read before handling.

Wiring

⚠ Caution

4. Avoid incorrect wiring.

<Reed switch>

A 24 VDC switch with indicator light has polarity. The brown [red] lead wire is (+), and the blue [black] lead wire is (-).

1) If connections are reversed, the switch will still operate, but the light emitting diode will not light up.

Also note that a current greater than the maximum specified one will damage a light emitting diode and make it inoperable.

Applicable models: D-A93, A93V

<Solid state switch>

1) If connections are reversed on a 2-wire type switch, the switch will not be damaged if protected by a protection circuit, but the switch will always stay in an ON state. However, it is still necessary to avoid reversed connections, since the switch could be damaged by a load short circuit in this condition.

2) If connections are reversed (power supply line + and power supply line -) on a 3-wire type switch, the switch will be protected by a protection circuit. However, if the power supply line (+) is connected to the blue wire and the power supply line (-) is connected to the black wire, the switch will be damaged.

<D-M9□, F6□>

D-M9□(V) does not have built-in short circuit protection circuit. Be aware that if the power supply connection is reversed (e.g. (+) power supply wire and (-) power supply wire connection is reversed), the switch will be damaged.

5. When the cable sheath is stripped, confirm the stripping direction. The insulator may be split or damaged depending on the direction. (D-M9□(V) only)

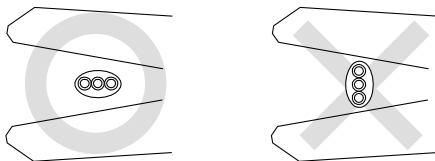

Recommended tool

Model name	Model no.
Wire stripper	D-M9N-SWY

* Stripper for a round cable (ø2.0) can be used for a 2-wire type cable.

Operating Environment

⚠ Warning

1. Never use in an atmosphere of explosive gases.

The construction of the auto switch is not intended to prevent explosion. Never use in an atmosphere with an explosive gas since this may cause a serious explosion.

2. Do not use in an area where a magnetic field is generated.

The auto switch will malfunction or the magnets inside of an actuator will become demagnetised if used in such an environment.

3. Do not use in an environment where the auto switch will be continually exposed to water.

The switch satisfies the IEC standard IP67 construction (JIS C 0920: watertight construction). Nevertheless, it should not be used in applications where it is continually exposed to water splash or spray. This may cause deterioration of the insulation or swelling of the potting resin inside switch causing a malfunction.

4. Do not use in an environment with oil or chemicals.

Consult with SMC if the auto switch will be used in an environment with coolant, cleaning solvent, various oils or chemicals. If the auto switch is used under these conditions for even a short time, it may be adversely affected by a deterioration of the insulation, a malfunction due to swelling of the potting resin, or hardening of the lead wires.

5. Do not use in an environment with temperature cycles.

Consult with SMC if the switch is used where there are temperature cycles other than normal temperature changes, as they may adversely affect the switch internally.

6. Do not use in an environment where there is excessive impact shock.

<Reed switch>

When excessive impact (300 m/s² or more) is applied to a reed switch during operation, the contact point may malfunction and generate a signal momentarily (1 ms or less) or cut off. Consult with SMC regarding the need to use a solid state switch in a specific environment.

7. Do not use in an area where surges are generated.

<Solid state switch>

When there are units (such as solenoid type lifters, high frequency induction furnaces, motors, etc.) that generate a large amount of surge in the area around an actuator with a solid state auto switch, their proximity or pressure may cause deterioration or damage to the internal circuit of the switch. Avoid sources of surge generation and crossed lines.



Series MSZ Auto Switch Precautions 4

Be sure to read before handling.

Operating Environment

Caution

1. Avoid accumulation of iron debris or close contact with magnetic substances.

When a large accumulated amount of ferrous waste such as machining chips or welding spatter, or a magnetic substance (something attracted by a magnet) is brought into close proximity to an actuator with auto switches, this may cause the auto switches to malfunction due to a loss of the magnetic force inside the actuator.

2. Contact SMC for the water resistance ability, the elasticity ability of the lead wire, and the welding site etc.

3. Do not expose the product to direct sunlight for an extended period of time.

4. Do not use the product in locations where it is exposed to radiant heat.

Maintenance

Warning

1. Perform the following maintenance periodically in order to prevent possible danger due to unexpected auto switch malfunction.

- 1) Securely tighten switch mounting screws.
If screws become loose or the mounting position is dislocated, retighten them after readjusting the mounting position.
- 2) Confirm that there is no damage to the lead wires.
To prevent faulty insulation, replace switches or repair lead wires, etc., if damage is discovered.
- 3) Confirm that the green light on the 2-colour display type switch lights up.
Confirm that the green LED is ON when stopped at the set position. If the red LED is ON, when stopped at the set position, the mounting position is not appropriate. Readjust the mounting position until the green LED lights up.

2. Perform the maintenance procedures outlined in the instruction manual.

If the maintenance procedures are performed improperly, malfunction or damage to the machinery or equipment may occur.

3. Removal of equipment, and supply/exhaust of compressed air.

When an equipment is serviced, first confirm that measures are in place to prevent workpieces from dropping run-away equipment, etc. Then cut the supply pressure and power, and exhaust all compressed air from the system using the residual pressure release function.

When the equipment is operated after remounting or replacement, first confirm that measures are in place to prevent lurching of actuators, etc. Then confirm that the equipment is operating normally.



Series MSZ / Specific product precautions

Be sure to read before handling.

Please refer to “Precautions for Handling Pneumatic Devices” (M-03-E3A) for Safety Instructions and Actuators/Auto Switch Precautions.

Operation which requires no stop at the centre position

⚠ Caution

1. End-to-end operation without stopping at the centre position includes situations such as decelerating or pausing around the centre position. Avoid use for applications in which speed change is a problem during end-to-end operation since the product may stop for max. 0.1s during high-speed rotation (0.2s/90) and for max. 0.5s during low-speed rotation (1s/90).

Breathing hole

⚠ Caution

1. The breathing holes located on the intermediate stopping part repeatedly absorb and release air. Care should be taken not to block the holes when mounting the product.

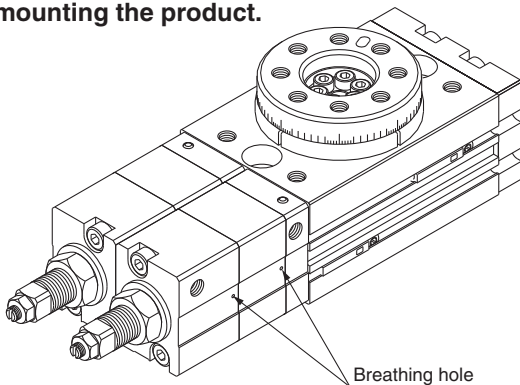

Mounting

⚠ Caution

1. Although any mounting direction is available with this product, when the gravity acting on the load acts in the direction of table rotation (e.g. the centre of gravity for the load and the rotation centre are not aligned when the rotation shaft is horizontal), stable rotation speed cannot be obtained.

In particular, since a meter-in speed controller controls the operation of rotating from the end to centre position, when the operating direction is the same as the direction the gravity acts on, then gravitational acceleration cannot be controlled, this may cause bouncing when it stops.

Backlash in the table at the centre position

⚠ Caution

1. Backlash in the table in the rotating direction can be controlled by adjusting the centre position properly. However, backlash (about 0.1) may occur as the rotation speed increases. If this causes any problems during operation, readjust the centre position.

Behaviour in the power-off condition

⚠ Caution

1. When a pressure-centre (PAB) type 3-position solenoid valve is used, the table as well as the solenoid valve return to the centre position when the power is cut due to blackouts, etc.

If the return position must be at a particular rotation end, either counterclockwise or clockwise when a blackout occurs, use two 3-port solenoid valves as shown below. Please refer to the table below for the solenoid valve type to be used.

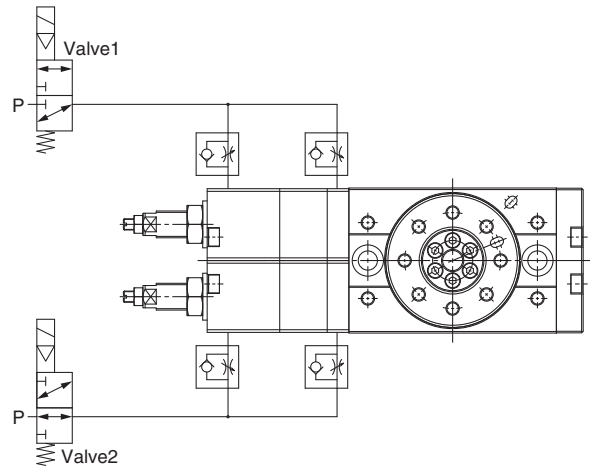

Reset position	Valve1	Valve2
Counterclockwise rotation end	Normally closed	Normally open
Clockwise rotation end	Normally open	Normally closed

If the stopped position must be held when the power is cut, use two 5-port double solenoid valves as shown below. (Plug the port, A or B, that is not being used.)

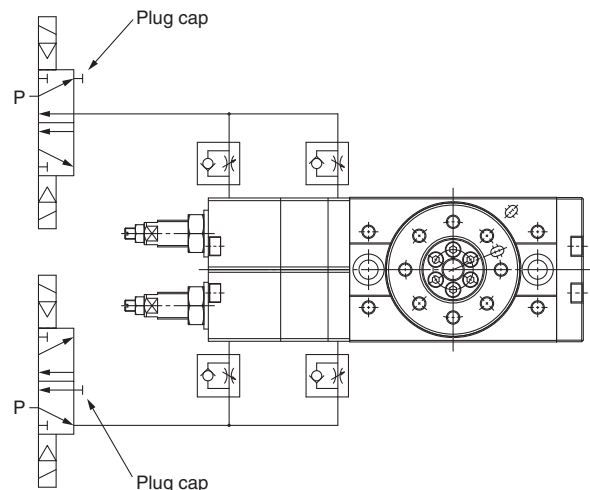



EUROPEAN SUBSIDIARIES:



Austria

SMC Pneumatik GmbH (Austria).
Girakstrasse 8, A-2100 Korneuburg
Phone: +43 2262-62280, Fax: +43 2262-62285
E-mail: office@smc.at
http://www.smc.at



France

SMC Pneumatique, S.A.
1, Boulevard de Strasbourg, Parc Gustave Eiffel
Bussy Saint Georges F-77607 Mame La Vallée Cedex 3
Phone: +33 (0)1-6476 1000, Fax: +33 (0)1-6476 1010
E-mail: contact@smc-france.fr
http://www.smc-france.fr



Netherlands

SMC Pneumatics BV
De Ruyterkade 120, NL-1011 AB Amsterdam
Phone: +31 (0)20-5318888, Fax: +31 (0)20-5318880
E-mail: info@smcpneumatics.nl
http://www.smcpneumatics.nl



Spain

SMC España, S.A.
Zuazobidea 14, 01015 Vitoria
Phone: +34 945-184 100, Fax: +34 945-184 124
E-mail: post@smc.smces.es
http://www.smces.es



Belgium

SMC Pneumatics N.V./S.A.
Nijverheidsstraat 20, B-2160 Wommelgem
Phone: +32 (0)3-355-1464, Fax: +32 (0)3-355-1466
E-mail: post@smcpneumatics.be
http://www.smcpneumatics.be



Germany

SMC Pneumatik GmbH
Boschring 13-15, D-63329 Egelsbach
Phone: +49 (0)6103-4020, Fax: +49 (0)6103-402139
E-mail: info@smc-pneumatik.de
http://www.smc-pneumatik.de



Norway

SMC Pneumatics Norway A/S
Vollsveien 13 C, Granfos Næringspark N-1366 Lysaker
Tel: +47 67 12 90 20, Fax: +47 67 12 90 21
E-mail: post@smc-norge.no
http://www.smc-norge.no



Sweden

SMC Pneumatics Sweden AB
Ekhagsvägen 29-31, S-141 71 Huddinge
Phone: +46 (0)8-603 12 00, Fax: +46 (0)8-603 12 90
E-mail: post@smcpneumatics.se
http://www.smc.nu



Bulgaria

SMC Industrial Automation Bulgaria EOOD
16 Kliment Ohridski Blvd., fl.13 BG-1756 Sofia
Phone: +359 2 9744492, Fax: +359 2 9744519
E-mail: office@smc.bg
http://www.smc.bg



Greece

S. Parianopoulos S.A.
7, Konstantinoupoleos Street, GR-11855 Athens
Phone: +30 (0)1-3426076, Fax: +30 (0)1-3455578
E-mail: parianos@hol.gr
http://www.smceu.com



Poland

SMC Industrial Automation Polska Sp.z.o.o.
ul. Konstruktorska 11A, PL-02-673 Warszawa,
Phone: +48 22 548 5085, Fax: +48 22 548 5087
E-mail: office@smc.pl
http://www.smc.pl



Switzerland

SMC Pneumatik AG
Dorfstrasse 7, CH-8484 Weisslingen
Phone: +41 (0)52-396-3131, Fax: +41 (0)52-396-3191
E-mail: info@smc.ch
http://www.smc.ch



Croatia

SMC Industrijska automatika d.o.o.
Cromerec 12, 10000 ZAGREB
Phone: +385 1 377 66 74, Fax: +385 1 377 66 74
E-mail: office@smc.hr
http://www.smceu.com



Hungary

SMC Hungary Ipari Automatizálási Kft.
Budafoki út 107-113, H-11117 Budapest
Phone: +36 1 371 1343, Fax: +36 1 371 1344
E-mail: office@smc-automation.hu
http://www.smc-automation.hu



Portugal

SMC Sucursal Portugal, S.A.
Rua de Engº Ferreira Dias 452, 4100-246 Porto
Phone: +351 22-610-89-22, Fax: +351 22-610-89-36
E-mail: postpt@smc.smces.es
http://www.smces.es



Turkey

Entek Prömatik San. ve Tic Ltd. Sti.
Peipa Tic. Merkezi Kat: 11 No: 1625, TR-80270 Okmeydanı Istanbul
Phone: +90 (0)212-221-1512, Fax: +90 (0)212-221-1519
E-mail: smc-entek@entek.com.tr
http://www.entek.com.tr



Czech Republic

SMC Industrial Automation CZ s.r.o.
Hudcova 78a, CZ-61200 Brno
Phone: +420 5 414 24611, Fax: +420 5 412 18034
E-mail: office@smc.cz
http://www.smc.cz



Ireland

SMC Pneumatics (Ireland) Ltd.
2002 Citywest Business Campus, Naas Road, Saggart, Co. Dublin
Phone: +353 (0)1-403 9000, Fax: +353 (0)1-464-0500
E-mail: sales@smcpneumatics.ie
http://www.smcpneumatics.ie



Romania

SMC Romania srl
Str Frunzei 29, Sector 2, Bucharest
Phone: +40 213205111, Fax: +40 213261489
E-mail: smcromania@smcromania.ro
http://www.smcromania.ro



UK

SMC Pneumatics (UK) Ltd
Vincent Avenue, Crownhill, Milton Keynes, MK8 0AN
Phone: +44 (0)800 1382930 Fax: +44 (0)1908-555064
E-mail: sales@smcpneumatics.co.uk
http://www.smcpneumatics.co.uk



Denmark

SMC Pneumatik A/S
Knudsminde 4B, DK-8300 Odder
Phone: +45 70252900, Fax: +45 70252901
E-mail: smc@smc-pneumatik.dk
http://www.smc.dk.com



Italy

SMC Italia S.p.A
Via Garibaldi 62, I-20061 Carugate, (Milano)
Phone: +39 (0)2-92711, Fax: +39 (0)2-9271365
E-mail: mailbox@smcitalia.it
http://www.smcitalia.it



Russia

SMC Pneumatik LLC.
4B Sverdlovskaja nab, St. Petersburg 195009
Phone: +812 718 5445, Fax: +812 718 5449
E-mail: info@smc-pneumatik.ru
http://www.smc-pneumatik.ru



Estonia

SMC Pneumatics Estonia OÜ
Laki 12-101, 106 21 Tallinn
Phone: +372 (0)6 593540, Fax: +372 (0)6 593541
E-mail: smc@smcpneumatics.ee
http://www.smcpneumatics.ee



Latvia

SMC Pneumatics Latvia SIA
Smerla 1-705, Riga LV-1006, Latvia
Phone: +371 781-77-00, Fax: +371 781-77-01
E-mail: info@smclv.lv
http://www.smclv.lv



Slovakia

SMC Priemyselna Automatizácia, s.r.o.
Námestie Martina Benku 10, SK-81107 Bratislava
Phone: +421 2 444 56725, Fax: +421 2 444 56028
E-mail: office@smc.sk
http://www.smc.sk



Finland

SMC Pneumatics Finland OY
PL72, Tiistintintintie 4, SF-02031 ESPOO
Phone: +358 207 513513, Fax: +358 207 513595
E-mail: smcffi@smc.fi
http://www.smc.fi



Lithuania

SMC Pneumatics Lietuva, UAB
Savanoriu pr. 180, LT-01354 Vilnius, Lithuania
Phone: +370 5 264 81 26, Fax: +370 5 264 81 26



Slovenia

SMC industrijska Avtomatika d.o.o.
Grajski trg 15, SLO-8360 Zuzemberk
Phone: +386 738 85240 Fax: +386 738 85249
E-mail: office@smc-ind-avtom.si
http://www.smc-ind-avtom.si



OTHER SUBSIDIARIES WORLDWIDE:

ARGENTINA, AUSTRALIA, BOLIVIA, BRASIL, CANADA, CHILE,
CHINA, HONG KONG, INDIA, INDONESIA, MALAYSIA, MEXICO,
NEW ZEALAND, PHILIPPINES, SINGAPORE, SOUTH KOREA,
TAIWAN, THAILAND, USA, VENEZUELA

<http://www.smceu.com>
<http://www.smcworld.com>