

Low Profile Slide Table Series **MXF**



How to Order

Low Profile Slide Table **MXF 12-50-F9N S**

Bore-Stroke (mm)

ø 8	10, 20, 30
ø 12	20, 30, 50
ø 16	30, 50, 75
ø 20	30, 50, 75, 100

Number of auto switches

—	2 pcs.
S	1 pc.
n	n pcs.

Auto switch

—	Without auto switch
---	---------------------

Select the auto switch from the list below.

How to Order Stroke Adjuster (Accessory)

MXF — A 16 27 — X11

Applicable cylinder bore size

8	ø8
12	ø12
16	ø16
20	ø20

Adjustable range

—	5mm	Standard
X11	15mm	Option
X12	25mm	

* -X12 (Adjustable range 25mm) is not available for series MXF8/MXF12.
* -X11 and -X12 are not available as built-in product.

Applicable Auto Switches/Refer to p.5.3-2 for the detailed specifications on auto switches.

Style	Special function	Electrical entry	Indicator	Wiring (Output)	Load voltage			Auto switch model		Lead wire length		Applicable load	
					DC	AC		Electrical entry direction		0.5 (—)	3 (L)		
						24V	5V	100V or less	100V				
Reed switch	—	Grommet	No	2 wire	24V	5V	100V or less	A90V	A90	●	●	IC	Relay PLC
								A93V	A93	●	●	—	
Solid state switch	Diagnostic indication (2 color)	Grommet	Yes	3 wire (NPN)	24V	12V	—	F9NV	F9N	●	●	—	Relay PLC
				3 wire (PNP)				F9PV	F9P	●	●		
				2 wire				F9BV	F9B	●	●		
				3 wire (NPN)				F9NWV	F9NW	●	●		
				3 wire (PNP)				F9PWV	F9PW	●	●		
				2 wire				F9BWV	F9BW	●	●		

* Lead wire length 0.5m.....— (Example)A93
3m.....L (Example)A93L

Low Profile Slide Table *Series MXF*

Specifications



Bore size (mm)	ø 8	ø 12	ø 16	ø 20
Port size	M3 X 0.5	M5 X 0.8		
Fluid	Air			
Action	Double acting			
Operating pressure	0.15 to 0.7MPa			
Proof pressure	1.05MPa			
Ambient and fluid temperature	-10 to 60°C			
Operating speed range	50 to 500mm/s			
Cushion	Both ends rubber bumper			
Lubrication	Non-lube			
Auto switch (option)	Reed switch Solid state switch (2 wire, 3 wire) 2 color indication solid state switch (2 wire, 3 wire)			
Stroke tolerance	$+1_0$ mm			
Stroke adjustment range	Extend 5mm/Retract 5mm			

Theoretical Force

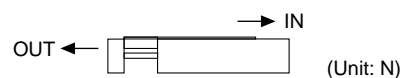

Bore size (mm)	Rod diameter (mm)	Operating direction	Piston area (mm ²)	Operating pressure (MPa)					
				0.2	0.3	0.4	0.5	0.6	0.7
8	4	OUT	50	10	15	20	25	30	35
		IN	38	8	11	15	19	23	27
12	6	OUT	113	23	34	45	57	68	79
		IN	85	17	26	34	43	51	60
16	8	OUT	201	40	60	80	101	121	141
		IN	151	30	45	60	76	91	106
20	10	OUT	314	63	94	126	157	188	220
		IN	236	47	71	94	118	142	165

Note) Theoretical force (N)=Pressure (MPa) X Piston area(mm²)

Standard Stroke

Model	Standard stroke (mm)
MXF8	10, 20, 30
MXF12	20, 30, 50
MXF16	30, 50, 75
MXF20	30, 50, 75, 100

Weight

Model	Standard stroke (mm)					
	10	20	30	50	75	100
MXF8	120	130	170	—	—	—
MXF12	—	210	250	360	—	—
MXF16	—	—	360	500	690	—
MXF20	—	—	600	750	1060	1370

- CL
- MLGC
- CNA
- CB
- CV/MVG
- CXW
- CXS
- CXT
- MX
- MXU
- MXS
- MXQ
- MXF**
- MXW
- MXP
- MG
- MGP
- MGQ
- MGG
- MGC
- MGF
- CY1
- MY1

Series MXF

Table Deflection

Table deflection by pitch moment

Table pitch deflection due to static pitch moment applied at arrow for all strokes of slide table.

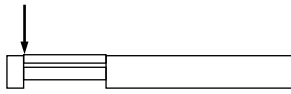

MXF 8

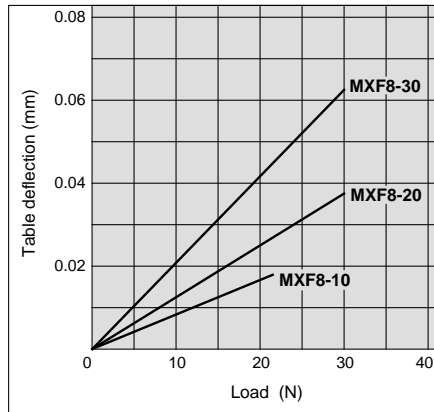

Table deflection by yaw moment

Table yaw deflection due to static yaw moment applied at arrow for all strokes of slide table.

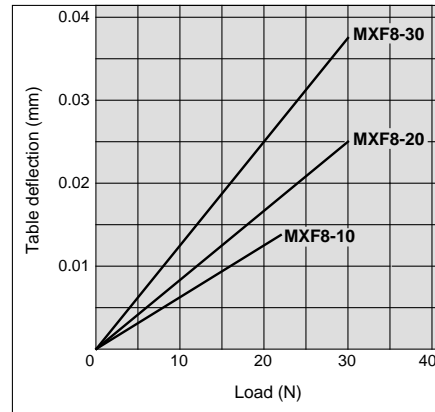
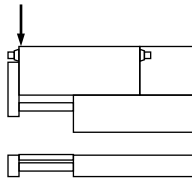
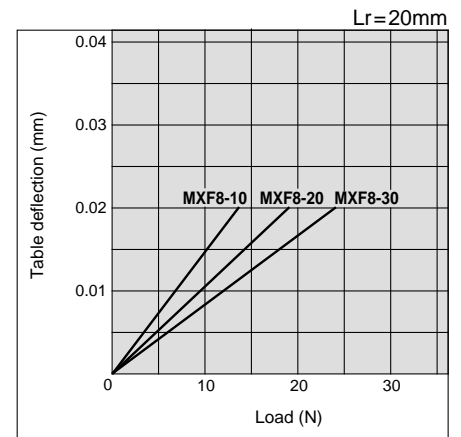
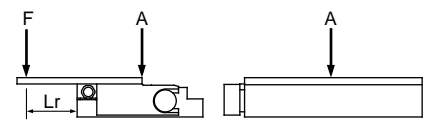
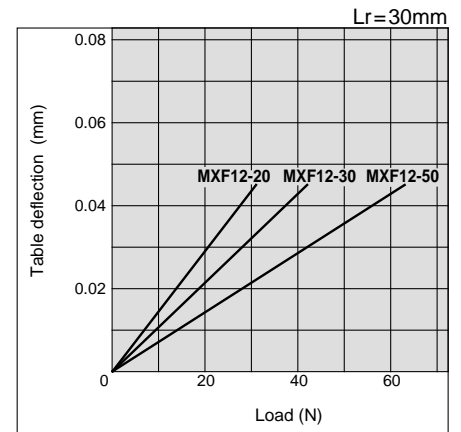
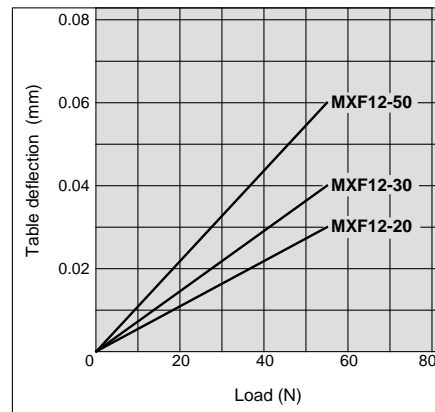
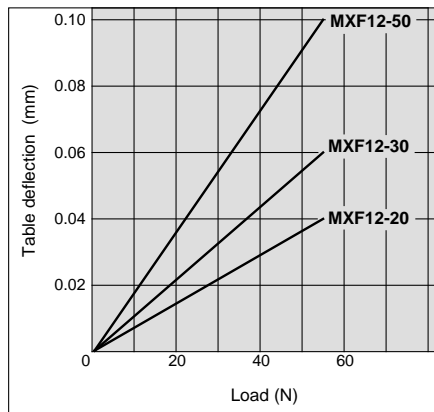

Table deflection by roll moment

Table roll deflection arrow A due to static roll moment applied at arrow F when Lr=20mm and table is retracted.



MXF 12



Allowable static moment

Model	Stroke (mm)	Allowable static moment: Mp, My, Mr (Nm)						Correction value for moment center distance (mm)					
		10	20	30	50	75	100	Cp1	Cp2	Cy1	Cy2	Cr1	Cr2
MXF8	16	0.56	0.78	0.98	—	—	—	6 ⁽¹⁾	10	6 ⁽¹⁾	21	21	10
MXF12	16	—	1.65	2.22	3.34	—	—	10	11	10	23	23	11
MXF16	16	—	—	3.41	5.69	7.96	—	10	12	10	28	28	12
MXF20	16	—	—	6.66	9.14	13.70	18.27	11	17	11	34	34	17

Note 1) 16mm only for MXF8-10.

Table deflection by pitch moment

Table pitch deflection due to static pitch moment applied at arrow for all strokes of slide table.

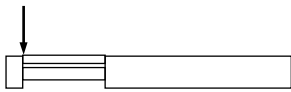

MXF 16

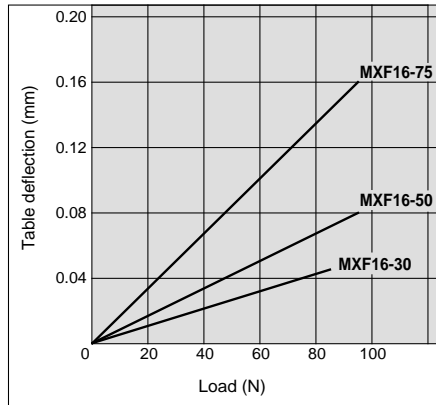

Table deflection by yaw moment

Table yaw deflection due to static yaw moment applied at arrow for all strokes of slide table.

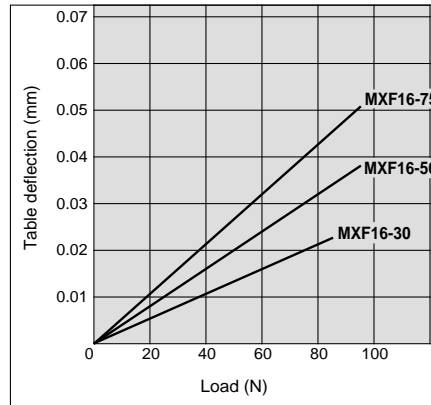
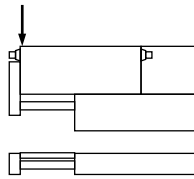
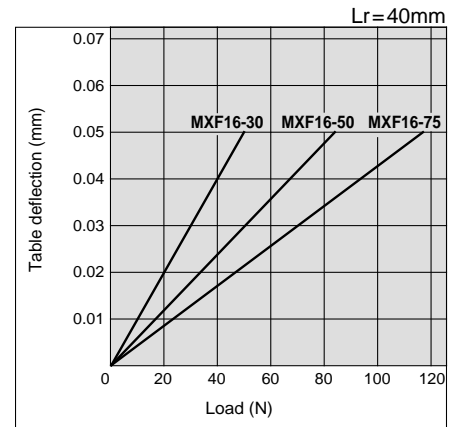
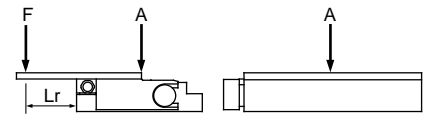
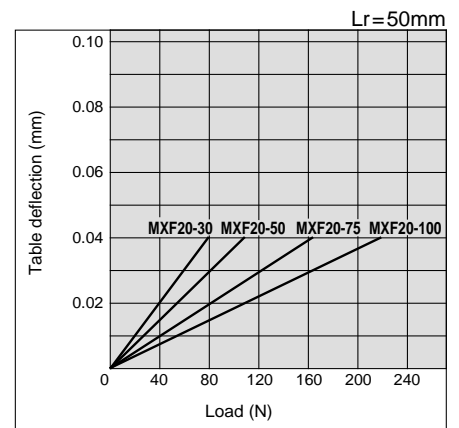
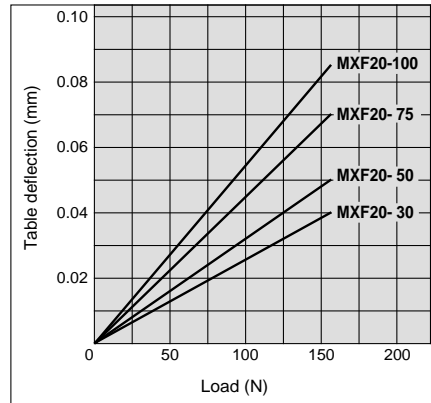
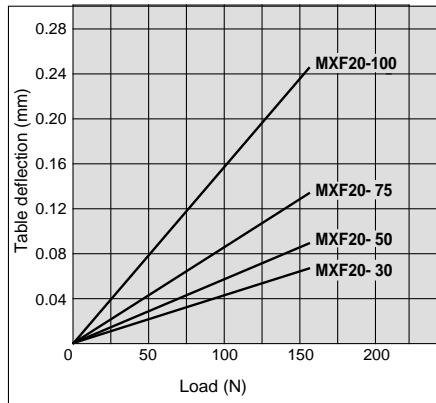

Table deflection by roll moment

Table roll deflection arrow A due to static roll moment applied at arrow F when Lr=20mm and table is retracted.



MXF 20



Formula for calculation of allowable static load, Fp, Fy and Fr

When pitch moment is applied	When yaw moment is applied	When roll moment is applied
$F_p = \frac{M_p \times 1000}{(L_p + C_p)} \quad (N)$ <p>Lp: Distance between body and load point(mm) Cp: Correction value for moment center distance(mm)</p>	$F_y = \frac{M_y \times 1000}{(L_y + C_y)} \quad (N)$ <p>Ly: Distance between body and load point(mm) Cy: Correction value for moment center distance(mm)</p>	$F_r = \frac{M_r \times 1000}{(L_r + C_r)} \quad (N)$ <p>Lr: Distance between body and load point(mm) Cr: Correction value for moment center distance(mm)</p>

⚠️ Precaution

Selection

⚠️ Caution

- ① If a table is stopped at an intermediate position by an external stopper, avoid ejection. If ejection occurs, it causes damage. If a slide table is stopped at an intermediate position by an external stopper and then forwarded to the front, draw back the intermediate stopper after supplying pressure to allow the slide table to return to the back for an instant, then supply pressure to the opposite port to operate the slide table.
- ② Do not use in circumstances that excessive, external forces or impacts would be applied. These conditions could lead to malfunctions.
- ③ Portable weight should be 1/10 or less of the allowable static load in consideration of the overhang or inertia.

CL

MLGC

CNA

CB

CV/MVG

CXW

CXS

CXT

MX

MXU

MXS

MXQ

MXF

MXW

MXP

MG

MGP

MGQ

MGG

MGC

MGF

CY1

MY1

Guide for Operation of Slide Table MXF

⚠ Precaution

Be sure to read before handling.
Refer to p.0-39 to 0-43 for Safety
Instructions and common precautions.

Mounting

⚠ Caution

- ① Do not scratch or dent the mounting side of the body, table or end plate. It causes play in the guide section and increases sliding resistance.
- ② Do not apply scratch or dent the forward side of the rail or guide. It can causes play of the guide section and increases sliding resistance.
- ③ Do not bring into close contact with objects which would be influenced by a magnetic field. As an air slide table has magnets built-in, do not allow close contact with magnetic disks, magnetic cards or magnetic tapes. Data may be erased.
- ④ When mounting an air slide table, screws of appropriate length should be used and tightened properly within the maximum tightening torque. If screws are tightened beyond designed limits, malfunction may occur. If they are tightened insufficiently, it may result in sliding from its position.
- ⑤ Be careful when adjusting stroke not to allow cylinder end plate to bottom out against cylinder body.

Positioning

⚠ Caution

- ① Pin holes are designed to allow accurate and repeated mounting.
- * Location of pin holes on top and bottom are not identical.

Slide Table Mounting

The slide table can be mounted from 2 directions. Select the best direction according to your application.

① Body tapped mounting

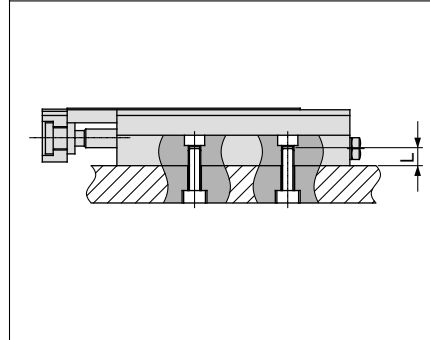

Model	Bolt used	Max. torque (Nm)	Max. screw-in depth L(mm)
MXF8	M4 X 0.7	2.1	4.7
MXF12	M4 X 0.7	2.1	6.5
MXF16	M5 X 0.8	4.4	6.7
MXF20	M5 X 0.8	4.4	8.5

② Through hole mounting

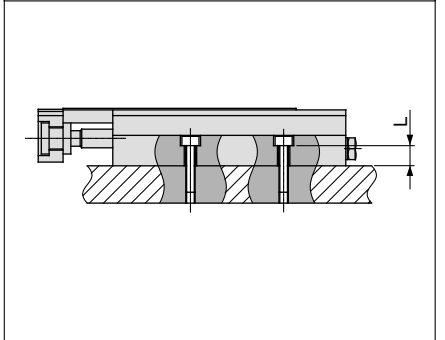

Model	Bolt used	Max. torque (Nm)	Max. screw-in depth L(mm)
MXF8	M3 X 0.5	1.2	4.7
MXF12	M3 X 0.5	1.2	6.5
MXF16	M4 X 0.7	2.8	6.7
MXF20	M4 X 0.7	2.8	8.5

⚠ **Caution** 0.02mm or less of flatness is recommended. An uneven mounting surface may cause play and increase sliding resistance.

Mounting of Work Piece

Work can be mounted on two sides of the air slide table.

① Front face mounting

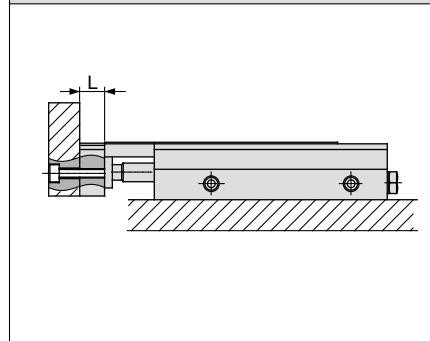

Model	Bolt used	Max. torque (Nm)	Max. screw-in depth L(mm)
MXF8	M3 X 0.5	0.9	6
MXF12	M3 X 0.5	0.9	6
MXF16	M4 X 0.7	2.1	10
MXF20	M5 X 0.8	4.4	12

② Top face mounting

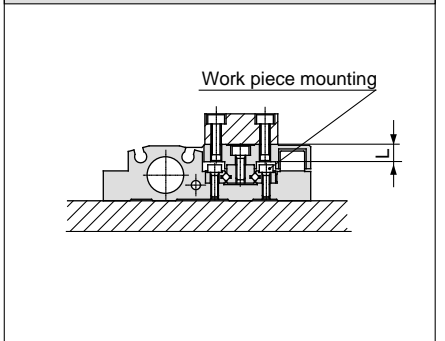

Model	Bolt used	Max. torque (Nm)	Max. screw-in depth L(mm)
MXF8	M3 X 0.5	0.9	6.5
MXF12	M3 X 0.5	0.9	5.5
MXF16	M4 X 0.7	2.1	6.5
MXF20	M5 X 0.8	4.4	9.5

⚠ Caution

Use bolts at least 0.5mm shorter than maximum thread depth to prevent bolts from contacting the end plate. If the bolts are too long, they hit the end plate and may cause malfunctions.

Construction

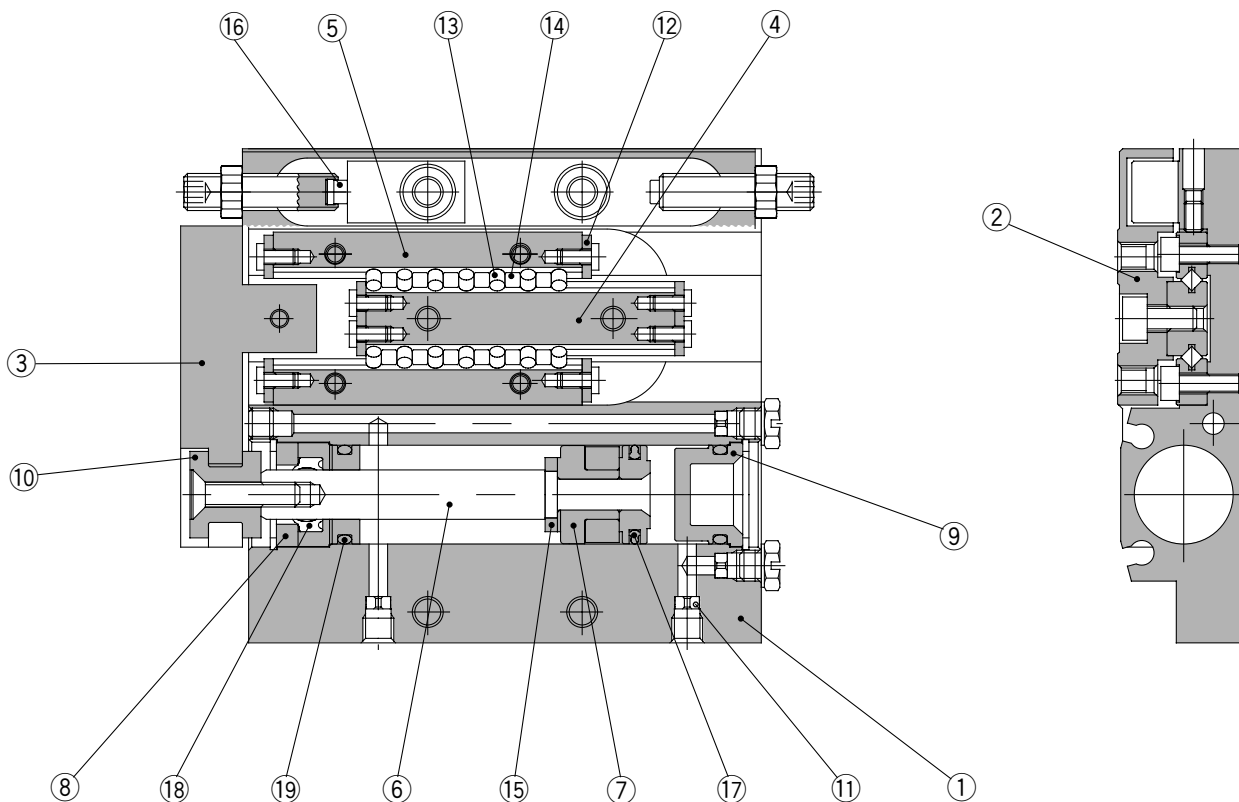

Component Parts

No.	Description	Material	Note
①	Body	Aluminum alloy	Hard anodized
②	Table	Aluminum alloy	Hard anodized
③	End plate	Aluminum alloy	Hard anodized
④	Rail	Carbon tool steel	Heat treatment
⑤	Guide	Carbon tool steel	Heat treatment
⑥	Rod	Stainless steel	
⑦	Piston assembly	—	With magnet
⑧	Seal retainer	Brass	Electroless nickel plated
⑨	Head cap	Resin	
⑩	Floating bushing	Stainless steel	
⑪	Orifice	Brass	Electroless nickel plated
⑫	Roller stopper	Stainless steel	
⑬	Cylindrical roller	High carbon chromium bearing	
⑭	Roller spacer	Resin	
⑮	Rod bumper	Polyurethane	

Component Parts

No.	Description	Material	Note
⑯	Adjustment bumper	Polyurethane	
⑰	Piston seal	NBR	
⑱	Rod seal	NBR	
⑲	O ring	NBR	

Replacement Parts: Seal Kits

Bore size (mm)	Kit No.	Note
8	MXF8-PS	1 set including ⑰ to ⑲
12	MXF12-PS	
16	MXF16-PS	
20	MXF20-PS	

* The parts indicated with the numbers ⑰, ⑱ and ⑲ are included in a seal kit. Specify the order numbers in compliance with respective cylinder bore size.

Stroke Adjuster Bolt/Dimensions

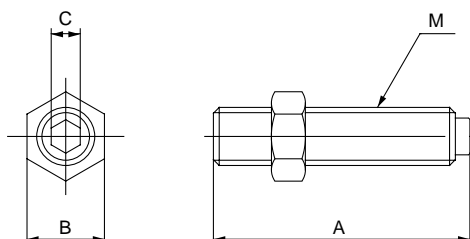

Model	Part No.	Stroke adj. range (mm)	A	B	C	M
MXF8	MXF-A827	5	17	6	2	M4 X 0.7
	MXF-A827-X11	15	27			
MXF12	MXF-A1227	5	23.5	7	2.5	M5 X 0.8
	MXF-A1227-X11	15	33.5			
MXF16	MXF-A1627	5	26.5	8	3	M6 X 1
	MXF-A1627-X11	15	36.5			
	MXF-A1627-X12	25	46.5			
MXF20	MXF-A2027	5	30	12	4	M8 X 1
	MXF-A2027-X11	15	40			
	MXF-A2027-X12	25	50			

CL
MLGC
CNA
CB
CV/MVG
CXW
CXS
CXT
MX
MXU
MXS
MXQ
MXF
MXW
MXP
MG
MGP
MGQ
MGG
MGC
MGF
CY1
MY1

Series MXF

Dimensions MXF **8** 

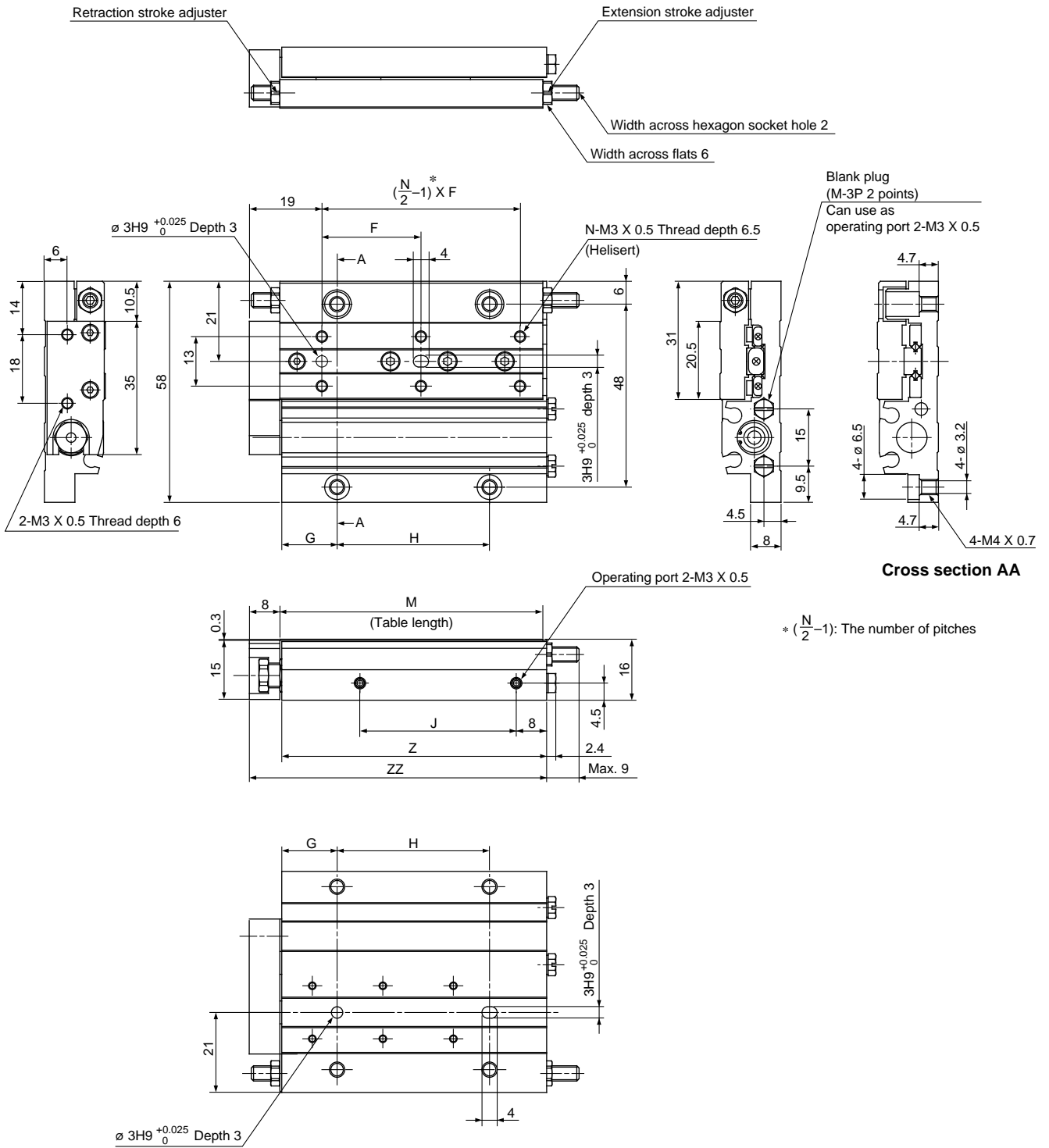

* $(\frac{N}{2}-1)$: The number of pitches

Model	F	N	G	H	J	M	Z	ZZ
MXF8-10	20	4	13.5	22	21	49	49.5	58
MXF8-20	26	4	14.5	26	26	54	54.5	63
MXF8-30	26	6	14.5	40	41	69	69.5	78

 With auto switch
 MXF8-10 SMXF8, #1(#1+#4)
 MXF8-20 SMXF8, #2(#2+#5)
 MXF8-30 SMXF8, #3(#3+#6)

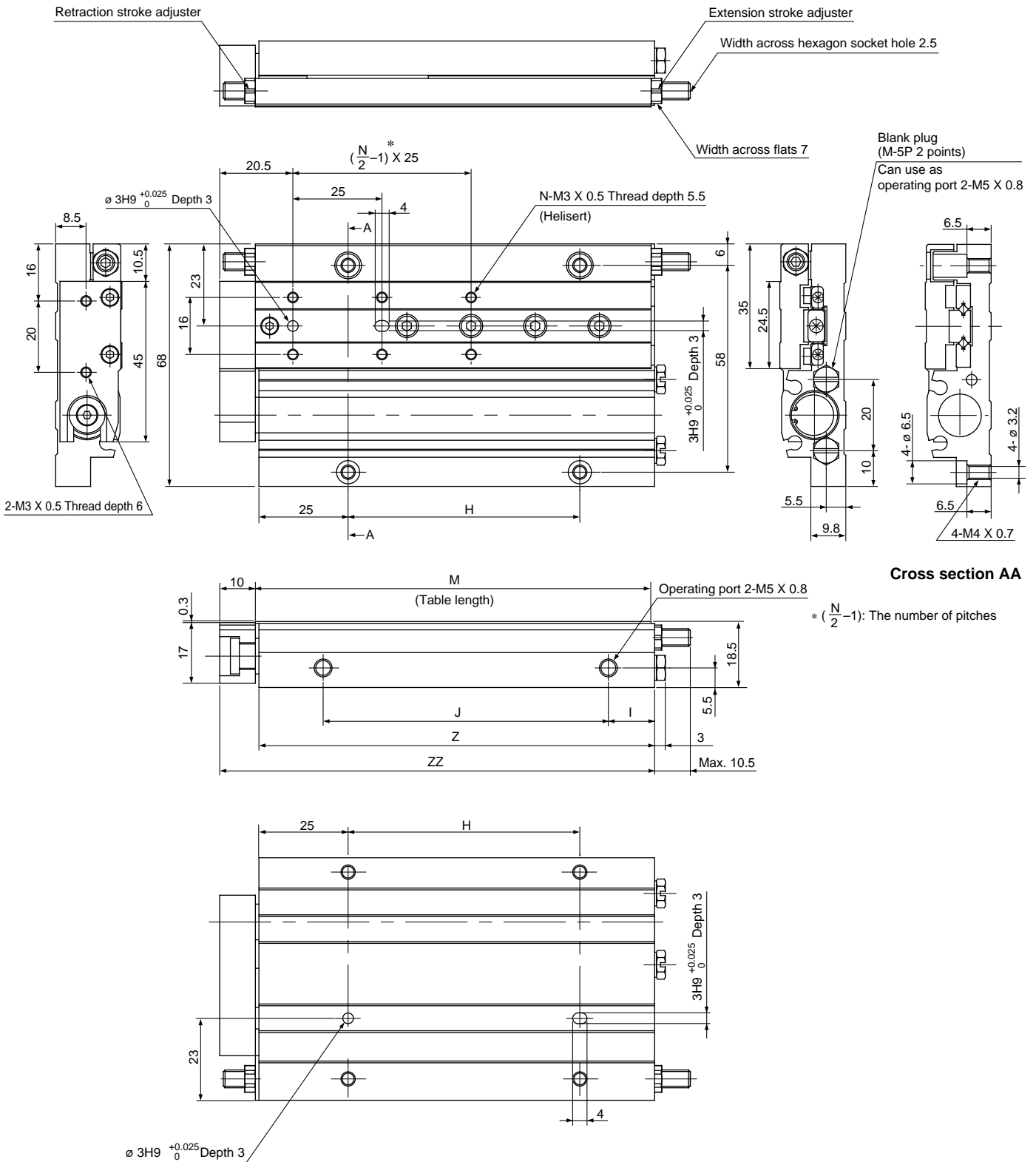

- CL
- MLGC
- CNA
- CB
- CV/MVG
- CXW
- CXS
- CXT
- MX
- MXU
- MXS
- MXQ
- MXF**
- MXW
- MXP
- MG
- MGP
- MGQ
- MGG
- MGC
- MGF
- CY1
- MY1

Model	N	H	I	J	M	Z	ZZ
MXF12-20	4	22	11	36	65	65	76
MXF12-30	4	30	12	45	75	75	86
MXF12-50	6	65	13	80	111	111	122

 With auto switch
 MXF12-20 SMXF12, #1(#1+#4)
 MXF12-30 SMXF12, #2(#2+#5)
 MXF12-50 SMXF12, #3(#3+#6)

Dimensions **MXF20**

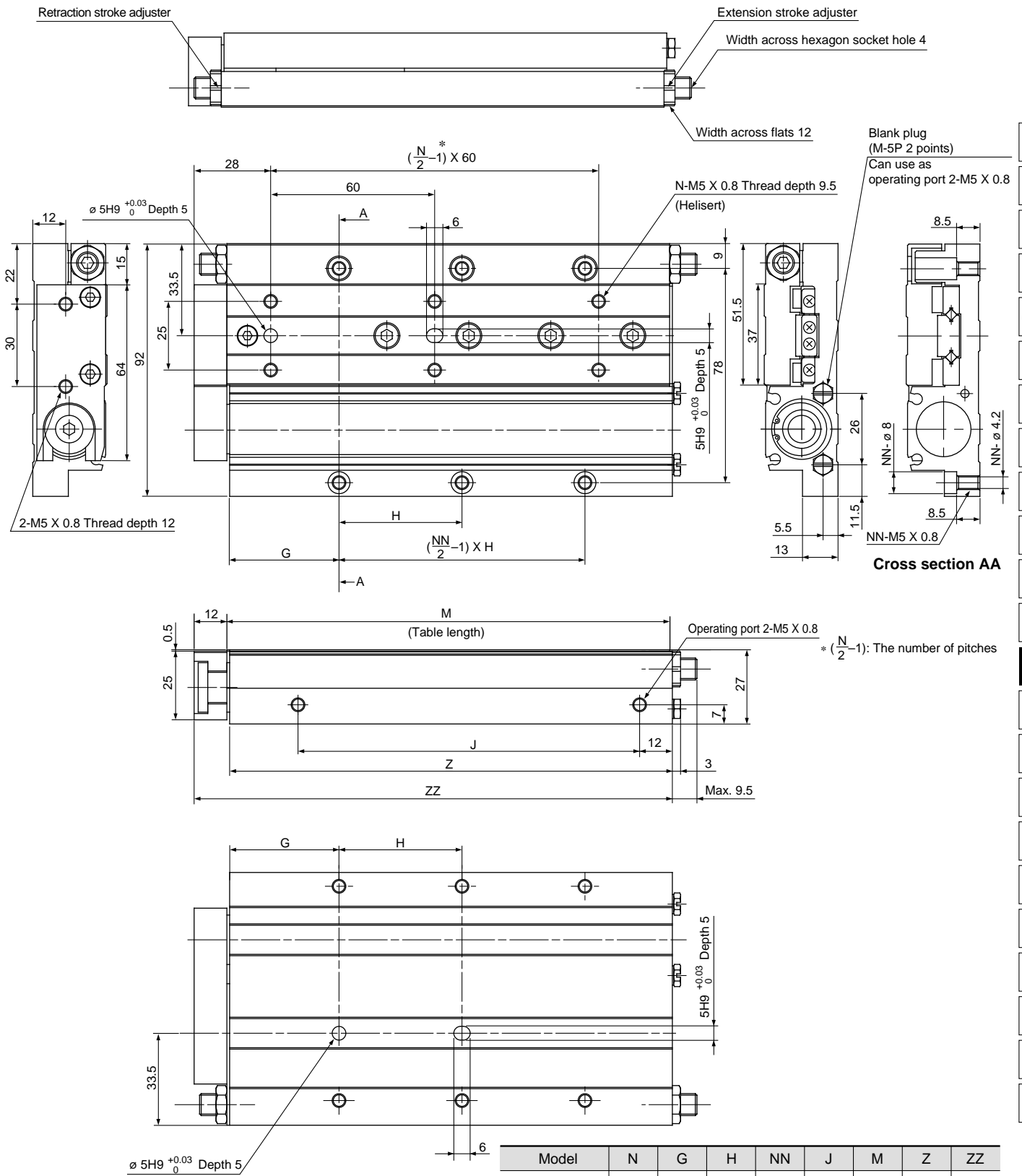

- CL
- MLGC
- CNA
- CB
- CV/MVG
- CXW
- CXS
- CXT
- MX
- MXU
- MXS
- MXQ
- MXF**
- MXW
- MPX
- MG
- MGP
- MGQ
- MGG
- MGC
- MGF
- CY1
- MY1

Model	N	G	H	NN	J	M	Z	ZZ
MXF20-30	4	29	30	4	57	91	91	104
MXF20-50	4	36	45	4	77	113	113	126
MXF20-75	6	40	45	6	125	162	162	175
MXF20-100	6	59	60	6	175	211	211	224

 With auto switch
 MXF20-30 SMXF20, #1(#1+#5) MXF20-75 SMXF20, #3(#3+#7)
 MXF20-50 SMXF20, #2(#2+#6) MXF20-100.....SMXF20, #4(#4+#8)

Solid-state Auto Switches for Direct Mounting Series D-M9N(V)/D-M9P(V)/D-M9B(V)



Grommet

- Reduced load currents for two-wire model (2.5 to 40 mA)
- Compliance with lead-free requirements
- Use of UL-approved lead wires (style 2844)



Internal circuits

D-M9N/M9NV

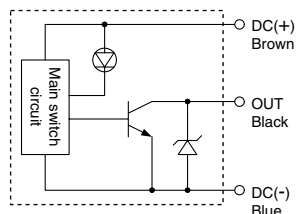

D-M9P/M9PV

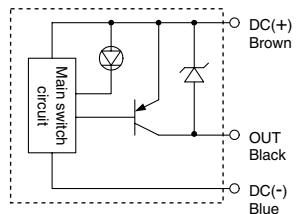

D-M9B/M9BV

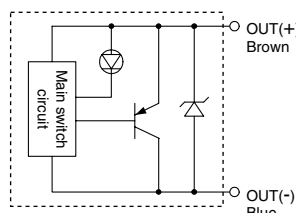

Auto Switch Specifications

PLC: Programmable Logic Controller

D-M9□/D-M9□V (with Indicator light)						
Model number	D-M9N	D-M9NV	D-M9P	D-M9PV	D-M9B	D-M9BV
Electrical entry	In-line	Perpendicular	In-line	Perpendicular	In-line	Perpendicular
Wiring	Three-wire			Two-wire		
Output	NPN		PNP		—	
Applicable load	Integrated circuit, relay and PLC				24 V DC relay and PLC	
Power voltage	5, 12, or 24 V DC (4.5 to 28 V DC)				—	
Current consumption	10 mA or less				—	
Load voltage	28 V DC or less		—		24 V DC (10 to 28 V DC)	
Load current	40 mA or less				2.5 to 40 mA	
Internal voltage drop	0.8 V or less				4 V or less	
Leakage current	100 μA max. at 24 V DC				0.8 mA or less	
Indicator light	Red LED lights when ON.					

- Lead wire: oil-proof heavy-duty vinyl cable
2.7 x 3.2 with elliptic cross-section, 0.15 mm², two cores (D-M9B),
or three cores (D-M9N and D-M9P)

Solid state switch specifications

Leakage current	3-wire: 100 μA or less; 2-wire: 0.8 mA max.
Operating time	1 ms or less
Impact resistance	1000 m/s ²
Insulation resistance	50 MΩ or more at 500 V DC (between lead wire and case)
Withstand voltage	1000 V AC for 1 min. (between lead wire and case)
Ambient temperature	-10°C to 60°C
Enclosure	IEC529 standard IP67, JIS C 0920 watertight construction

Weight

Unit: g

Model	D-M9N(V)	D-M9P(V)	D-M9B(V)
Lead wire length (m)	0.5	8	7
	3	41	38
	5	68	63

How to Order

Standard Model Number

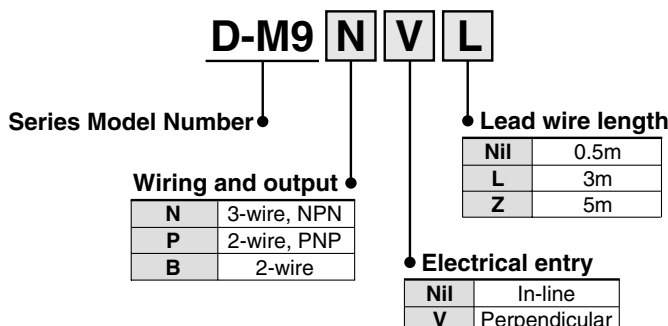

Series D-M9

Auto Switch Dimensions

D-M9□

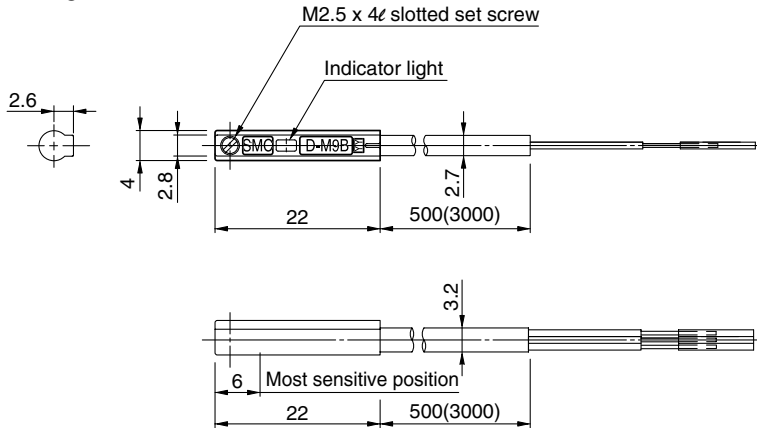

D-M9□V

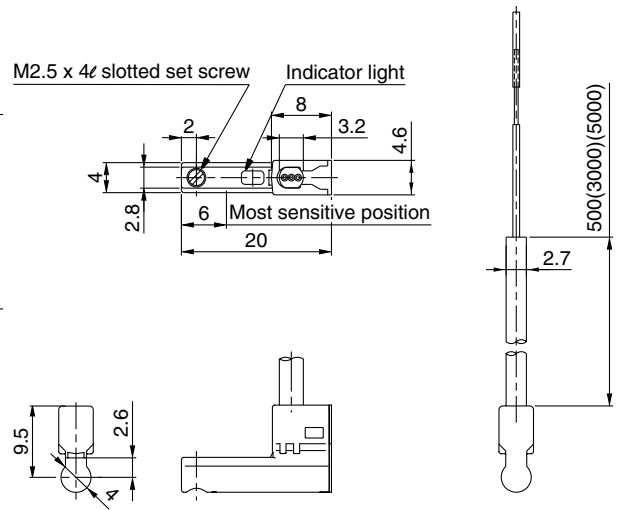

⚠ Specific Product Precautions

Be sure to read before handling. Contact SMC when the required specification is out of range.

Handling

⚠ Caution

Observe the following precautions when handling the product.

- The D-M9 series of auto switches is not overcurrent-protected. Faulty wiring or short circuit may result in breakage or burning-out of the switch.
- When stripping the cable clad, be careful about the orientation of the cable being stripped. The insulator may be accidentally torn or damaged depending on the orientation, as shown on the right.

- We recommend the following tools

Manufacturer	Product name	Product number
VESSEL	Wire stripper	No 3000G
Tokyo Ideal	Strip master	45-089

* The stripper for the round shape cords (ø2.0) is for a 2-wire style.

- Please do not attach the switch with any other screws than those already attached to the auto switch body.

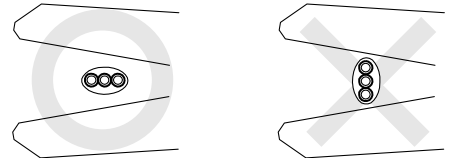

The operation range is shorter than that of the conventional models.

If the auto switch replaces the conventional model, it may not function depending on its application because the operation range is shorter. Refer to the examples below.

- In an application where at the end, the stopping position shifting range is larger than the operation range. For example, pushing a work against something, or pressing a work into a hole, or clamping a work.
- In an application where the auto switch is used to detect an intermediate stopping position. (Detecting time is shortened.)

Note) Please contact SMC for the operation range details for each actuator.

The switch is damaged instantly when a load is shortened since short circuit protection is not built-in. Pay special attention to avoid reversing the connection of the brown lead of the power supply line and the black output line connection.