



# Operation Manual

PRODUCT NAME

Air slide table / Reversible type

MODEL/ Series

MXQR \* \*(L)

**SMC Corporation**

# Contents

Safety Instructions .....	3,4
1. Specifications	
1-1 Specifications .....	5,6
1-2 Optional specifications .....	7
2. How to use	
2-1 Mounting .....	8~10
2-2 Precautions for mounting the adjuster on the left .....	10
2-3 Air supply .....	10
2-4 Piping .....	11
2-5. Environment .....	11
2-6 Lubricating .....	12
2-7 Handling of optional adjuster .....	12,13
2-8 Precautions for mounting optional adjuster .....	14
2-9 Mounting of auto switch .....	15
3. Maintenance	
3-1 Precautions for maintenance .....	15
3-2. Addition of grease .....	15
3-3 Construction/Parts list .....	16
4. Change of adjuster mounting position	
4-1 Removal of accessories .....	17
4-2 Removal of body .....	17
4-3 Confirmation of mounting of body and guide .....	18
4-4 Fixing of body and guide .....	19,20
4-5 Mounting accessories .....	20,21
4-6 Completion of change .....	21
4-7 Removal of cap .....	21



# Safety Instructions

These safety instructions are intended to prevent hazardous situations and/or equipment damage. These instructions indicate the level of potential hazard with the labels of "Caution," "Warning" or "Danger." They are all important notes for safety and must be followed in addition to International Standards (ISO/IEC), Japan Industrial Standards (JIS)\*1) and other safety regulations\*2).

\*1) ISO 4414: Pneumatic fluid power -- General rules relating to systems

ISO 4413: Hydraulic fluid power -- General rules relating to systems

IEC 60204-1: Safety of machinery -- Electrical equipment of machines (Part 1: General requirements)

ISO 10218-1992: Manipulating industrial robots -- Safety

JIS B 8370: General rules for pneumatic equipment.

JIS B 8361: General rules for hydraulic equipment.

JIS B 9960-1: Safety of machinery -- Electrical equipment for machines. (Part 1: General requirements)

JIS B 8433-1993: Manipulating industrial robots - Safety, etc.

\*2) Labor Safety and Sanitation Law, etc.



## Caution

Caution indicates a hazard with a low level of risk which, if not avoided, could result in minor or moderate injury.



## Warning

Warning indicates a hazard with a medium level of risk which, if not avoided, could result in death or serious injury.



## Danger

Danger indicates a hazard with a high level of risk which, if not avoided, will result in death or serious injury.



## Warning

### 1. The compatibility of the product is the responsibility of the person who designs the equipment or decides its specifications.

Since the product specified here is used under various operating conditions, its compatibility with specific equipment must be decided by the person who designs the equipment or decides its specifications based on necessary analysis and test results. The expected performance and safety assurance of the equipment will be the responsibility of the person who has determined its compatibility with the product. This person should also continuously review all specifications of the product referring to its latest catalog information, with a view to giving due consideration to any possibility of equipment failure when configuring the equipment.

### 2. Only personnel with appropriate training should operate machinery and equipment.

The product specified here may become unsafe if handled incorrectly. The assembly, operation and maintenance of machines or equipment including our products must be performed by an operator who is appropriately trained and experienced.

### 3. Do not service or attempt to remove product and machinery/equipment until safety is confirmed.

The inspection and maintenance of machinery/equipment should only be performed after measures to prevent falling or runaway of the driven objects have been confirmed. When the product is to be removed, confirm that the safety measures as mentioned above are implemented and the power from any appropriate source is cut, and read and understand the specific product precautions of all relevant products carefully. Before machinery/equipment is restarted, take measures to prevent unexpected operation and malfunction.

### 4. Contact SMC beforehand and take special consideration of safety measures if the product is to be used in any of the following conditions.

1) Conditions and environments outside of the given specifications, or use outdoors or in a place exposed to direct sunlight.

2) Installation on equipment in conjunction with atomic energy, railways, air navigation, space, shipping, vehicles, military, medical treatment, combustion and recreation, or equipment in contact with food and beverages, emergency stop circuits, clutch and brake circuits in press applications, safety equipment or other applications unsuitable for the standard specifications described in the product catalog.

3) An application which could have negative effects on people, property, or animals requiring special safety analysis.

4) Use in an interlock circuit, which requires the provision of double interlock for possible failure by using a mechanical protective function, and periodical checks to confirm proper operation.



# Safety Instructions

## Caution

**The product is provided for use in manufacturing industries.**

The product herein described is basically provided for peaceful use in manufacturing industries.

If considering using the product in other industries, consult SMC beforehand and exchange specifications or a contract if necessary.

If anything is unclear, contact your nearest sales branch.

## Limited warranty and Disclaimer/Compliance Requirements

The product used is subject to the following “Limited warranty and Disclaimer” and “Compliance Requirements”.

Read and accept them before using the product.

### Limited warranty and Disclaimer

**The warranty period of the product is 1 year in service or 1.5 years after the product is delivered.\*3)**

**Also, the product may have specified durability, running distance or replacement parts. Please consult your nearest sales branch.**

**For any failure or damage reported within the warranty period which is clearly our responsibility, a replacement product or necessary parts will be provided.**

**This limited warranty applies only to our product independently, and not to any other damage incurred due to the failure of the product.**

**Prior to using SMC products, please read and understand the warranty terms and disclaimers noted in the specified catalog for the particular products.**

**\*3) Vacuum pads are excluded from this 1 year warranty.**

**A vacuum pad is a consumable part, so it is warranted for a year after it is delivered.**

**Also, even within the warranty period, the wear of a product due to the use of the vacuum pad or failure due to the deterioration of rubber material are not covered by the limited warranty.**

### Compliance Requirements

When the product is exported, strictly follow the laws required by the Ministry of Economy, Trade and Industry (Foreign Exchange and Foreign Trade Control Law).

# 1. Specifications

## 1-1 Specifications

### (1) Product

Model	MXQR6	MXQR8	MXQR12	MXQR16	MXQR20	MXQR25
Bore size (mm)	6	8	12	16	20	25
Port size	M5X0.5				Rc1/8,NPT1/8,G1/8	
Fluid	Air					
Action	Double acting					
Operating pressure	*10.15 to 0.7 MPa					
Proof pressure	1.05 MPa					
Ambient and fluid temperature	-10 to 60 °C (No freezing)					
Operating speed range	50 to 500 mm/s Adjuster option/ Metal stopper: 50 to 200mm/s With shock absorber: 300 to 500mm/s (only for MXQR6)					
Cushion	Rubber bumper (standard, adjuster option/rubber stopper) Shock absorber (adjuster option/shock absorber*2) None (adjuster option/metal stopper)					
Lubrication	Not required (non-lube)					
Auto switch	Reed auto switch (2-wire and 3-wire) Solid state auto switch (2-wire and 3-wire) 2-color display solid state auto switch (2-wire and 3-wire)					
Stroke length tolerance	+1 0		mm			

\*1 MXQR6 with shock absorber: Operating pressure 0.3MPa to 0.7MPa

\*2 The MXQR6 series does not have an RJ short stroke type (JS and JT).

### (2) Standard stroke

Model	Standard stroke (mm)
<b>MXQR 6</b>	10, 20, 30, 40, 50
<b>MXQR 8</b>	10, 20, 30, 40, 50, 75
<b>MXQR12</b>	10, 20, 30, 40, 50, 75, 100
<b>MXQR16</b>	10, 20, 30, 40, 50, 75, 100, 125
<b>MXQR20</b>	10, 20, 30, 40, 50, 75, 100, 125, 150
<b>MXQR25</b>	10, 20, 30, 40, 50, 75, 100, 125, 150

### (3) Theoretical force

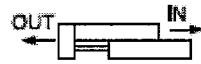

The dual rod ensures an output twice that of existing cylinders.

(N)

Bore size (mm)	Rod size (mm)	Operating direction	Piston area (mm <sup>2</sup> )	Operating pressure (MPa)					
				0.2	0.3	0.4	0.5	0.6	0.7
6	3	OUT	57	11	17	23	29	34	40
		IN	42	8	13	17	21	25	29
8	4	OUT	101	20	30	40	51	61	71
		IN	75	15	23	30	38	45	53
12	6	OUT	226	45	68	90	113	136	159
		IN	170	34	51	68	85	102	119
16	8	OUT	402	80	121	161	201	241	281
		IN	302	60	91	121	151	181	211
20	10	OUT	628	126	188	251	314	377	440
		IN	471	94	141	188	236	283	330
25	12	OUT	982	196	295	393	491	589	687
		IN	756	151	227	302	378	454	529

Note) Theoretical output (N) = Pressure (MPa) x Piston area (mm<sup>2</sup>)

### (4) Weight

(g)

Model	Standard stroke (mm)									Additional weight of adjuster option					
	10	20	30	40	50	75	100	125	150	Rubber stopper		Shock absorber		Metal stopper	
	Extension end		Retraction end		Extension end		Retraction end		Extension end		Retraction end				
MXQR 6	100	120	140	180	200	—	—	—	—	6	5	14	10	10	5
MXQR 8	140	170	210	250	315	385	—	—	—	10	10	30	23	23	10
MXQR12	335	340	380	450	490	655	745	—	—	25	23	47	30	35	23
MXQR16	605	610	670	735	835	1000	1250	1400	—	45	40	75	53	60	40
MXQR20	1100	1100	1100	1200	1400	1750	2350	2650	2900	80	65	170	120	115	65
MXQR25	1750	1750	1750	1950	2400	2750	3450	4300	4700	130	110	220	140	180	110

### (5) Table accuracy

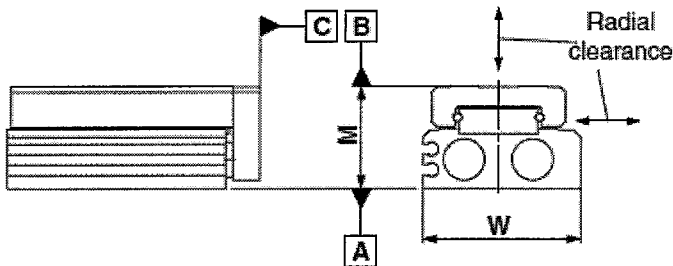

Table (1) B Side Parallelism to A Side

(mm)

Model	Stroke (mm)								
	10	20	30	40	50	75	100	125	150
MXQR 6	0.025	0.03	0.035	0.04	0.045	—	—	—	—
MXQR 8	0.025	0.03	0.035	0.04	0.055	0.065	—	—	—
MXQR12	0.03	0.03	0.035	0.04	0.045	0.065	0.075	—	—
MXQR16	0.035	0.035	0.04	0.045	0.05	0.065	0.08	0.095	—
MXQR20	0.04	0.04	0.04	0.045	0.055	0.07	0.095	0.105	0.125
MXQR25	0.045	0.045	0.045	0.05	0.06	0.07	0.09	0.115	0.125

Model	MXQR6	MXQR8	MXQR12	MXQR16	MXQR20	MXQR25
B side parallelism to A side	Refer to Table (1).					
B side traveling parallelism to A side	Refer to Graph (1).					
C side perpendicularity to A side	0.05 mm					
M dimension tolerance	±0.08 mm (±0.1 mm) *1					
W dimension tolerance	±0.1 mm					
Radial internal clearance (μm)	-4 to 0	-4 to 0	-6 to 0	-10 to 0	-12 to 0	-14 to 0

\*1) ±0.1 mm for 75 mm or longer stroke

Graph (1) B Side Traveling Parallelism to A Side (mm)

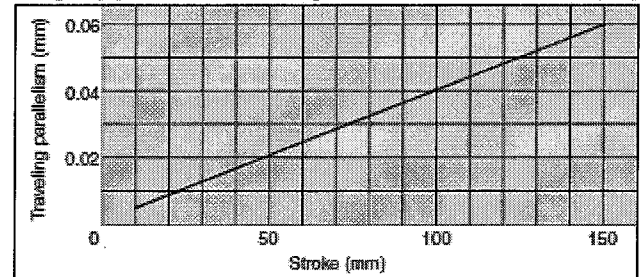

## 1-2 Optional specifications

### (1) Adjuster

Stroke adjusting range

Type	Details	Stroke adjusting range
Rubber stopper	Extension end (AS)	0 to 5mm
	Retraction end (AT)	
	Both ends (A)	
Shock absorber	Extension end (BS,JS)	0 to 12mm: MXQR6 (only for BS and BT), 0 to 20mm: MXQR8 0 to 18mm: MXQR16, 0 to 22mm: MXQR12 0 to 35mm: MXQR20, 25
	Retraction end (BT,JT)	
	Both ends (B,J)	
Metal stopper	Extension end (CS)	0 to 5mm
	Retraction end (CT)	
	Both ends (C)	

### (2) Specifications of shock absorber

Model of Shock absorber	RB0604 -X2062	RB0805	RB0806	RB1007	RB1411	RB1412	RJ0805	RJ1006	RJ1410	
Applicable slide table	MXQR6	MXQR8	MXQR12	MXQR16	MXQR20	MXQR25	MXQR8,12	MXQR16	MXQR20,25	
Maximum absorbed energy J	0.5	0.98	2.94	5.88	14.7	19.6	0.5	1.5	3.7	
Stroke absorbed mm	4	5	6	7	11	12	5	6	10	
Collision speed mm/s	300 to 500	50 to 500								
Maximum operating frequency cycles/min.	-	80	80	70	45	45	80	70	45	
Maximum allowable thrust N	150	245	245	422	814	814	245	422	814	
Ambient temperature range °C	-10 to 60°C (No freezing)									
Spring force N	Extended	1.34	1.96	1.96	4.22	6.86	6.86	2.8	5.4	6.4
	Retracted	3.89	3.83	4.22	6.86	15.3	15.98	4.9	8.0	14.6
Weight g	5.5	15	15	25	65	65	15	23	65	

## 2. How to use

For use of actuators, refer to the Precautions in Best Pneumatics No. 3.

### 2-1 Mounting

#### (1) Mounting of body

Three types of installation are available according to the machine or work piece.

##### 1) Horizontal mounting (Tapped hole)

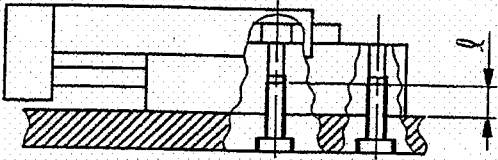

Model	Bolt	Maximum tightening torque Nm	Maximum screw-in depth l mm
MXQR 6	M4X0.7	2.1	8
MXQR 8	M4X0.7	2.1	8
MXQR12	M5X0.8	4.4	10
MXQR16	M6X1	7.4	12
MXQR20	M6X1	7.4	12
MXQR25	M8X1.25	18.0	16

##### 2) Horizontal mounting (Through hole)

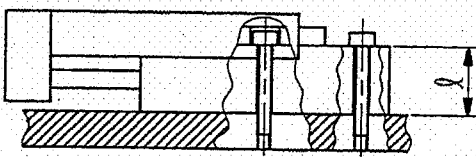

Model	Bolt	Maximum tightening torque Nm	Body thickness l mm
MXQR 6	M3X0.5	1.2	11.5
MXQR 8	M3X0.5	1.2	13.5
MXQR12	M4X0.7	2.8	17.4
MXQR16	M5X0.8	5.7	22.4
MXQR20	M5X0.8	5.7	27.4
MXQR25	M6X1	10.0	33.4

##### 3) Vertical mounting (Tapped hole on side)

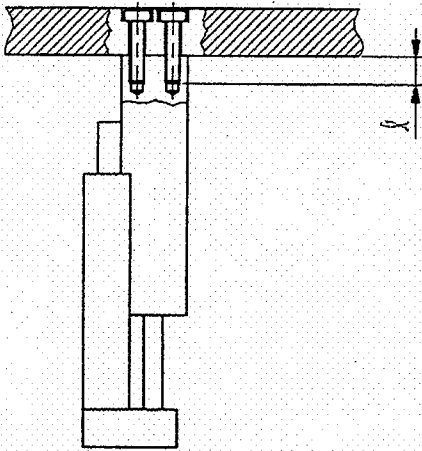

Model	Bolt	Maximum tightening torque Nm	Maximum screw-in depth l mm
MXQR 6	M2.5X0.45	0.5	4
MXQR 8	M3X0.5	0.9	4
MXQR12	M4X0.7	2.1	6
MXQR16	M5X0.8	4.4	7
MXQR20	M5X0.8	4.4	8
MXQR25	M6X1	7.4	10



(2) Mounting of work piece

1) Front mounting

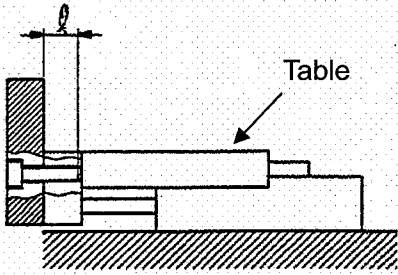

Model	Bolt	Maximum tightening torque Nm	Maximum screw-in depth l mm
MXQR 6	M3X0.5	0.9	5
MXQR 8	M4X0.7	2.1	6
MXQR12	M5X0.8	4.4	8
MXQR16	M6X1	7.4	10
MXQR20	M6X1	7.4	13
MXQR25	M8X1.25	18.0	15

**Caution**

In order to prevent the work piece fixing bolt from hitting the table, use a bolt of a length at least 0.5 mm shorter than the maximum screw-in depth. Longer bolts can hit the table, which causes operation failure.

2) Top mounting

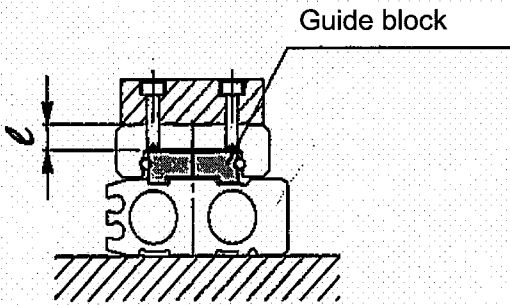

Model	Bolt	Maximum tightening torque Nm	Maximum screw-in depth l mm
MXQR 6	M3X0.5	1.2	4
MXQR 8	M3X0.5	1.2	4.8
MXQR12	M4X0.7	2.8	6
MXQR16	M5X0.8	5.7	7
MXQR20	M5X0.8	5.7	9.5
MXQR25	M6X1	10.0	11.5

**Caution**

In order to prevent the work piece fixing bolt from hitting the guide block, use a bolt of a length at least 0.5 mm shorter than the maximum screw-in depth. Longer bolts can hit the guide block, which causes operation failure.

(3) Precautions for mounting

**Caution**

- 1) Do not attach magnets to the table. The table is made of magnetic material. It will become magnetized if magnets are attached to it, which may cause the malfunction of auto switches, etc.
- 2) Do not damage the mounting surface of the body, table and end plate. Damage can cause reduction in flatness, play at the guide and increase in sliding resistance.
- 3) Do not dent or scratch the rolling surface of the guide block and table. Play or increased sliding resistance can result.
- 4) Do not apply strong impact or an excessive moment while mounting a work piece. If an external force more than the allowable moment is applied, it may cause play at the guide part and cause an increase in sliding resistance.
- 5) Keep the flatness of the mounting surface 0.002 mm or less. Insufficient flatness of a work piece or base mounted on the product can cause play at the guide and an increase in the sliding resistance.
- 6) When connecting a load with an external support or guide mechanism, perform careful alignment.
- 7) Do not touch the product while in operation. An operator's finger may get caught between the optional adjuster and product.

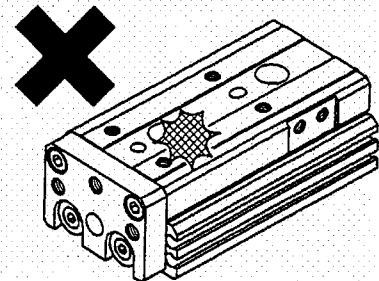

- Install a cover as a safety measure if an operator can get close to the slide table during operation.
- 8) Keep away objects which are affected by magnets.  
Since the product has built-in magnets, do not allow magnetic disks, magnetic cards or magnetic tapes to come close. Data may be erased.
- 9) When mounting the product, tighten it with screws of appropriate length at an appropriate torque less than the maximum tightening torque.  
Tightening to a torque greater than the specified range may cause malfunction, and insufficient tightening may cause displacement or dropping.

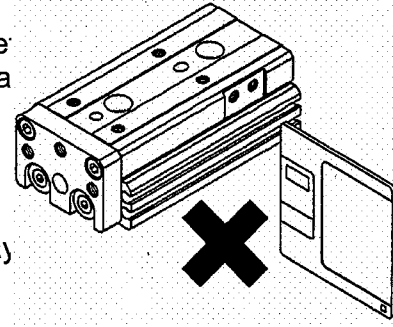

## 2-2 Precautions for mounting the adjuster on the left

### ⚠ Caution

Keep at least 3mm between adjusters mounted on the right and left when they are side by side. If there is not sufficient space between the adjusters, the auto switch may malfunction.

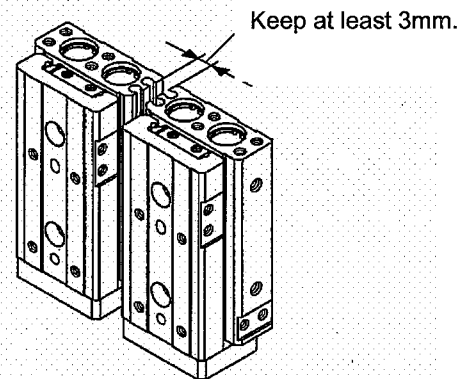

## 2-3 Air supply

### ⚠ Warning

#### (1) Type of fluids

The operating fluid must be compressed air. Contact SMC if using the product with other fluids.

#### (2) Large amount of condensate

Do not use compressed air containing a lot of condensate, which can cause operating failure of the pneumatic equipment. Install an air dryer or drain catch before the filter.

#### (3) Draining control

If an air filter is not drained, condensate will leak to the secondary side and cause operation failure of the pneumatic equipment. When it is difficult to control drainage, the use of a filter with an auto drain is recommended. For the details of compressed air mentioned above, refer to SMC catalog "Compressed Air Purification System".

#### (4) Types of air

Do not use compressed air which contains chemicals, synthetic oils containing organic solvents, salts or corrosive gases, etc., as this can cause damage or malfunction.

### ⚠ Caution

**1) If ultra dry air is used as a fluid, it can reduce the lubrication characteristics of equipment and affect the reliability (life) of equipment. Contact SMC beforehand.**

#### 2) Install an air filter.

Install an air filter close to the upstream side of the valve. A filtration degree of 5 $\mu$ m or less should be selected.

#### 3) Install an aftercooler, air dryer or drain catch before the filter and take appropriate measures.

Do not use compressed air containing a lot of condensate, which can cause the operating failure of the product and other pneumatic equipment.

#### 4) Use the product within the specified fluid and ambient temperature range.

When operating at temperatures below 5°C, water in the circuit may freeze and cause breakage of seals or malfunction. Corrective measures should be taken to prevent freezing.

For the details of compressed air mentioned above, refer to SMC catalog "Compressed Air Purification System".

## 2-4 Piping

### Caution

- 1) For the handling of one-touch fittings, refer to the Precautions for fittings and tubing in Best Pneumatics No. 6.
- 2) Before piping  
Before piping, perform air blow (flushing) or cleaning to remove any cutting chips, cutting oil, dust, etc. from the piping.

### 3) Sealant tape

When installing piping or fitting into a port, prevent cutting chips and sealant material from getting inside the piping. If a sealant tape is used, leave 1.5 to 2 threads exposed at the end of threads.

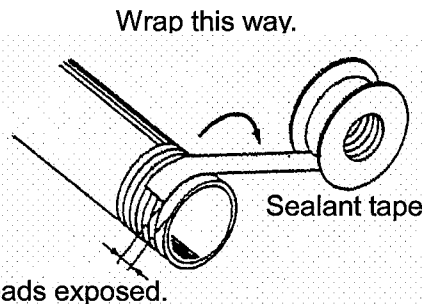

## 2-5. Environment

### Warning

- 1) Do not use in an environment where corrosive gases, chemicals, sea water, water or steam are present.
- 2) If using in a location directly exposed to sunlight, shade the product from the sunlight.
- 3) Do not operate in a location subject to vibration or impact.
- 4) Do not use in a place where there are heat sources around the product and it can receive radiant heat.
- 5) Install a cover over the rod if it is used in an area that is dusty, or in an environment in which water or oil splashes on the cylinder.
- 6) When using auto switches, do not operate in an environment with strong magnetic fields.
- 7) Refer to Shock Absorber Precautions if using a product with a shock absorber.
- 8) Grease oil can decrease depending on the properties of the compressed air used with the pneumatic equipment, external environment and operating conditions. This may reduce the lubrication performance and shorten the life of the product.

### Caution

- 1) Lubricant and grease oil may seep out of the product in some operating conditions. Contact SMC, especially if a clean environment is required.
- 2) Do not use in an environment where the product is directly exposed to liquid, such as cutting oil. If cutting oil, coolant or oil mist splashes the product, play, increased sliding resistance and air leakage can result. If the product is used in such an environment, contact SMC.
- 3) Do not use the product in an environment directly exposed to foreign matter such as dust, cutting chips and spatter. This can result in play, increased operating resistance, air leakage, etc.
- 4) Note the corrosion resistance of the linear guide. The table and guide block use martensite stainless steel, but it is inferior to austenitic stainless steel in terms of corrosion resistance. Especially, rust may be generated in an environment that allows water drops from condensation to stay on the surface.

## 2-6 Lubricating

### Warning

#### Lubricating

The product has been lubricated for life by the manufacturer, and does not require lubrication in service. If a lubricant is used in the system, use turbine oil Class 1 (with no additive) ISO VG32. Do not use machine oil or spindle oil.

Once lubricant is used in the system, lubrication must be continued because the original lubricant applied during manufacturing will be washed away.

When a turbine oil is used, refer to its Material Safety Datasheet (MSDS), and take appropriate measures and handle safely.

## 2-7 Handling of optional adjuster

(1) Stroke adjuster (rubber stopper/metal stopper)

### Caution

- 1) When replacing the bolt, do not replace it with a bolt other than the designated adjust bolt. Impact force may cause play, damage, etc.
- 2) Tighten the lock nut according to the tightening torque shown in the table on the right.  
Insufficient tightening may reduce the positioning accuracy.  
The shock absorber uses different torques, which are shown on the next page.
- 3) Be careful not to hit the table with the wrench when adjusting the stroke adjuster.  
This may cause play.

Model	Tightening torque Nm
MXQR 6	3.0
MXQR 8	5.0
MXQR12	12.5
MXQR16	25.0
MXQR20	43.0
MXQR25	69.0

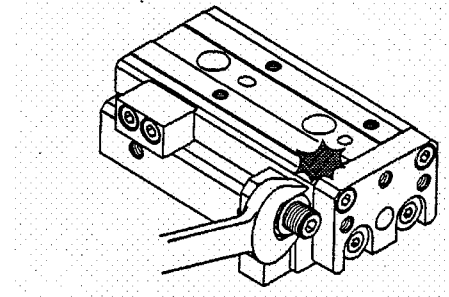

(2) Shock absorber

**⚠ Caution**

- 1) Do not turn the screws at the bottom of the shock absorber body.  
They are not for adjustment.  
This may lead to oil leakage.
- 2) Do not damage the sliding surface of the piston rod of the shock absorber.  
Otherwise, impaired durability and return failure can result.

Piston rod

Do not turn the screws at the bottom.

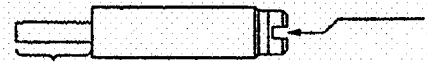

Do not damage.

- 3) Tighten the lock nut of the shock absorber according to the tightening torque shown in the table on the right.
- 4) For details of handling the shock absorber, refer to the Operation Manual and catalog of the RB and RJ.

Model	Tightening torque Nm
MXQR 6	0.85
MXQR 8	1.67
MXQR12	1.67
MXQR16	3.14
MXQR20	10.8
MXQR25	10.8

5) Life and replacement period of shock absorber

As a guide, the number of operating cycles which the product can last when used according to the catalog is as follows.

1.2 million cycles: RB0604-X2062

RB08□□

2 million cycles: RB10□□ to RB14□□

3 million cycles: RJ0805 to RJ1410

Note) The life time (appropriate replacement period) is at an ordinary temperature (20 to 25°C).

It depends on the operating conditions such as temperature, so in some cases the product will need to be replaced sooner than the above value.

Model	Model of shock absorber	
MXQR 6	RB0604-X2062	—
MXQR 8	RB0805	RJ0805
MXQR12	RB0806	
MXQR16	RB1007	RJ1006
MXQR20	RB1411	RJ1410
MXQR25	RB1412	

## 2-8 Precautions for mounting optional adjuster

### (1) Rubber stopper, shock absorber and metal stopper

#### Caution

In some models, the bolt for mounting the adjuster parts to the body and the bolt for mounting the stopper parts to the table have different lengths.

- Rubber stopper: For MXQR6 and 8 with stroke adjuster (AS) for extension end
- Shock absorber: For MXQR6, 20 and 25 with shock absorber (BS and JS) for extension end.
- Metal stopper: For MXQR6, 8, 20 and 25 with stroke adjuster (CS) for retraction end

Assembly using a bolt with inappropriate length can cause operating failure.

The length of the hexagon socket head bolt is as shown in the table below.

Model	Thread size of stroke adjuster at extension end						Thread size of stroke adjuster at retraction end
	AS		BS·JS		CS		AT,BT,JT,CT
	Body mounting section	Table mounting section	Body mounting section	Table mounting section	Body mounting section	Table mounting section	Body mounting section
MXQR 6	M2.5X6	M2.5X8	M2.5X6	M2.5X8	M2.5X6	M2.5X8	M2.5X9
MXQR 8	M3X8	M3X10	M3X12	M3X12	M3X8	M3X10	M3X11
MXQR12	M4X12	M4X12	M4X12	M4X12	M4X12	M4X12	M4X14
MXQR16	M5X16	M5X16	M5X16	M5X16	M5X16	M5X16	M5X18
MXQR20	M6X16	M6X16	M6X18	M6X20	M6X16	M6X20	M5X18
MXQR25	M8X18	M8X18	M8X18	M8X20	M8X18	M8X20	M6X22

### (2) Tighten the mounting bolt of the rubber stopper, shock absorber and metal stopper according to the table below.

Insufficient tightening may reduce the positioning accuracy and cause operating failure.

Model	Body and table mounting section of stroke adjuster at extension end (AS, BS, JS, CS)		Stroke adjuster at retraction end (AT, BT, JT, CT)	
	Thread size	Tightening torque Nm	Thread size	Tightening torque Nm
MXQR 6	M2.5	0.5	M2.5	0.5
MXQR 8	M3	0.9	M3	0.9
MXQR12	M4	2.1	M4	2.1
MXQR16	M5	4.4	M5	4.4
MXQR20	M6	7.0		
MXQR25	M8	18.0	M6	7.0

## 2-9 Mounting of auto switch

### Caution

- 1) Auto switch mounting tool  
For the tightening of the mounting screws (attached to the auto switch), use a watchmaker's screwdriver with a handle diameter of about mm.

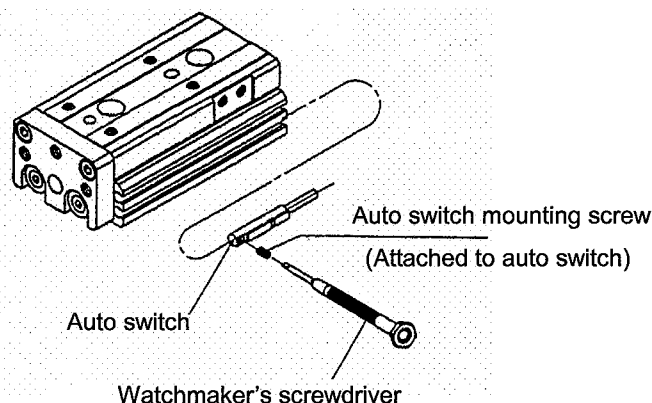

### 2) Tightening torque

Tightening torque of auto switch mounting screws

Auto switch model	Tightening torque Nm
D-A9□(V)	0.10 to 0.20
D-M9□(V)、D-M9□W(V)	0.05 to 0.15

## 3. Maintenance

### 3-1 Precautions for maintenance

#### Warning

- 1) Maintenance should be performed according to the procedure indicated in the Operation Manual. Improper handling can cause damage and malfunction of equipment and machinery.
- 2) Maintenance work  
Improper handling of compressed air is dangerous. Therefore, replacement of elements and other maintenance activities should be performed by personnel with sufficient knowledge and experience pertaining to pneumatic equipment.
- 3) Draining  
Remove condensate from air filters regularly.
- 4) Removal of equipment, and supply/exhaust of compressed air  
When equipment is serviced, first confirm that measures are in place to prevent dropping of driven objects and or equipment running out of control, etc. Then cut the supply pressure and the power of facilities, and exhaust all compressed air from the system. Before restarting the equipment, confirm that measures are taken to prevent sudden extension.

### 3-2. Addition of grease

#### Caution

- 1) Applying additional grease on the guide  
Grease is applied to this product by the manufacturer, it is not necessary to apply further grease in the life time of the product. If the grease is replenished, use the specified grease. (Specific grease part number: GR-S)
- 2) Replacement of piston seal  
A specific grease is prepared. Apply it to the piston seal and sliding part. (Specific grease part number: GR-L)

### 3-3 Construction/Parts list

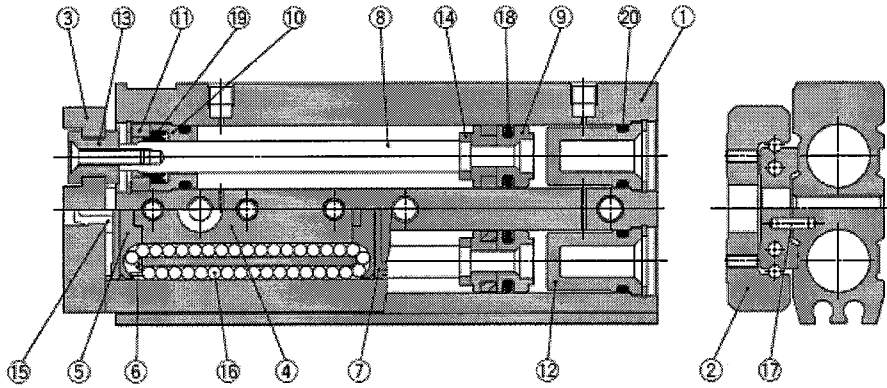

#### Parts list

No.	Description	Material	Remarks
1	Body	Aluminum alloy	Hard anodized
2	Table	Stainless steel	Heat treatment
3	End plate	Aluminum alloy	Hard anodized
4	Guide block	Stainless steel	Heat treatment
5	Cover	Synthetic resin	
6	Return guide	Synthetic resin	
7	Scraper	Stainless steel, NBR	
8	Rod	Stainless steel	
9	Piston assembly		With magnet on one side
10	Rod cover	Aluminum alloy	Anodized
11	Seal support	Brass	Electroless nickel plating
12	Head cap	Synthetic resin	
13	Floating bushing	Stainless steel	
14	Rod bumper	Polyurethane	
15	End bumper	Polyurethane	
16	Steel ball	High carbon chromium bearing steel	
17	Spring pin	Stainless steel	
18	Piston seal	NBR	
19	Rod seal	NBR	
20	O-ring	NBR	

#### Replacement part: Seal kit\*

Bore size (mm)	Standard type	
	Part no.	Content
6	MXQ 6-PS	1 set of numbers above 18 to 20
8	MXQ 8-PS	
12	MXQ12-PS	
16	MXQ16-PS	
20	MXQ20-PS	
25	MXQ25-PS	

#### Replacement part: Grease package

Applied section	Grease package part number
Guide	GR-S-010 (10g)
	GR-S-020 (20g)
Cylinder	GR-L-005 (5g)
	GR-L-010 (10g)

\*For the seal kit, the part number on the right table is for one set. Order with applicable part number to each cylinder bore size.



## 4. Change of adjuster mounting position

### 4-1 Removal of accessories

- (1) Mount the cap (enclosed with the product) in the position shown in the figure on the right to fix the table and guide block. The position should be at "a" if using one guide block, and "a" and "b" if using two guide blocks.

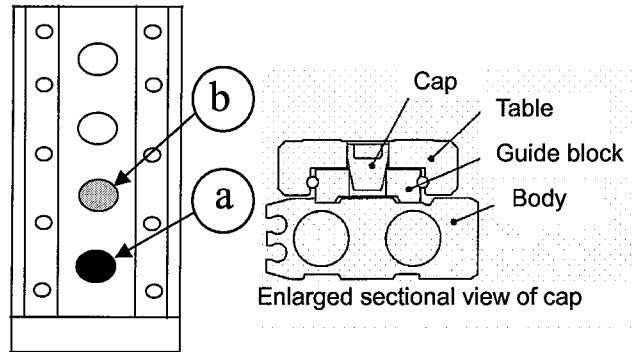

Note) If the guide block comes off, it will be difficult to reassemble the steel balls.

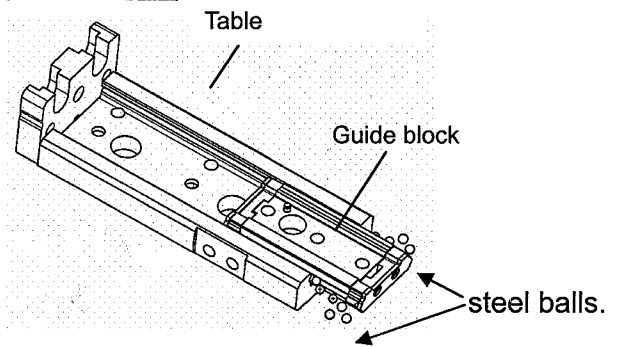

- (2) Remove accessories (parts for adjuster and stopper).

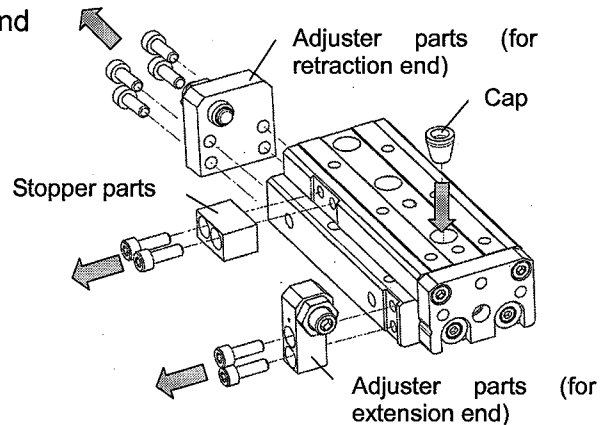

### 4-2 Removal of body

Turn the product over and remove the body fixing bolts. Then turn the body back over.

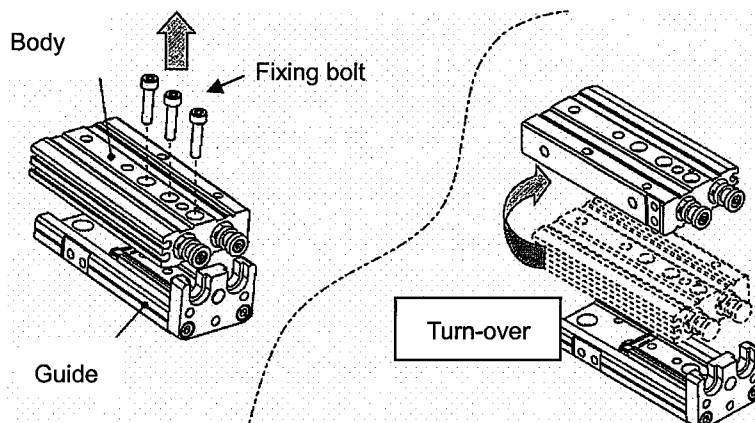

### 4-3 Confirmation of mounting of body and guide

- (1) Remove all dust from the body and guide mounting surfaces shown in the figure on the right. (If dust gets caught, it will reduce the accuracy of the table.)

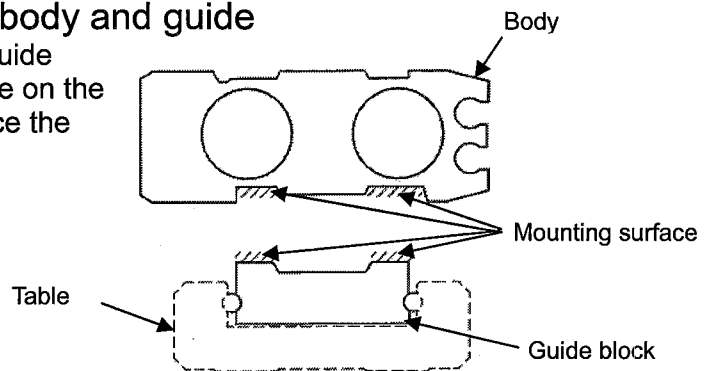

- (2) Gently place the body onto the guide and combine them in the position shown below.

- (1) Body pin hole (small hole) and guide block pin
- (2) Floating part at rod end and U groove on floating part

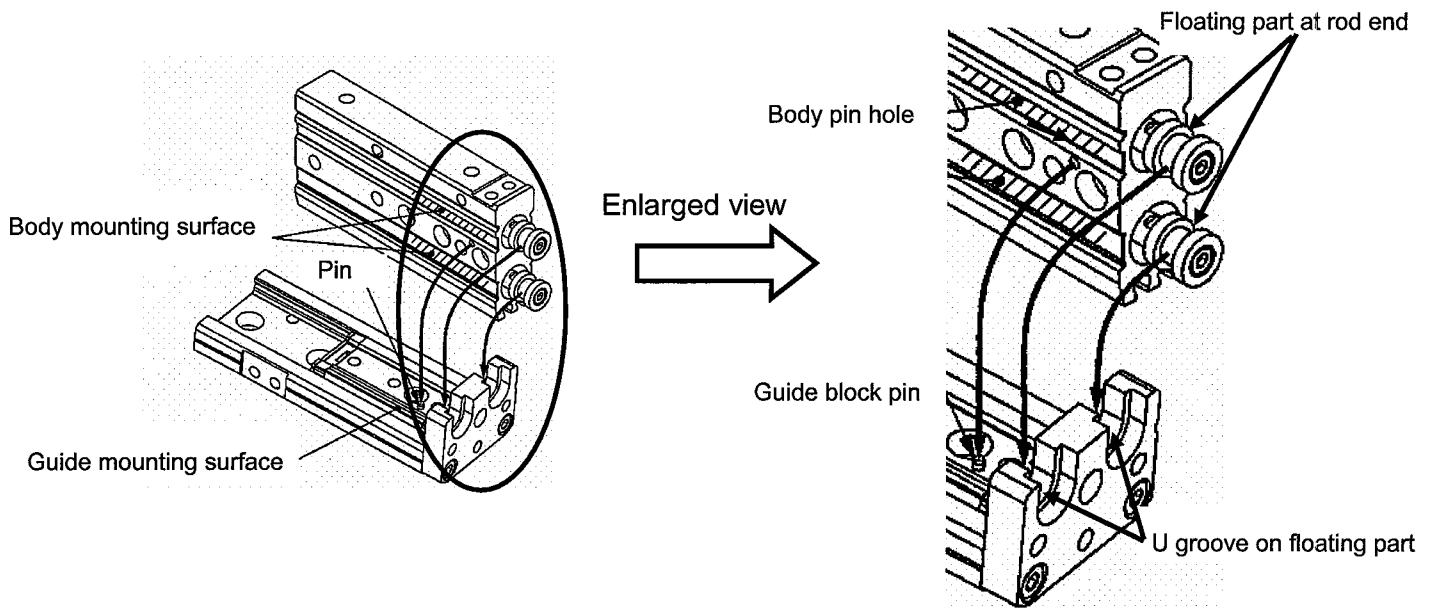

## 4-4 Fixing of body and guide

- (1) Remove the locking adhesive from the fixing bolts and clean them thoroughly. Apply locking adhesive at the end of the screw. For the curing time, refer to the catalog of the adhesive used, and take this into consideration when mounting the product on the machine.

The procedure for cleaning the fixing bolt is as follows.

- 1) Remove the residue of locking adhesive on the removed bolt using an organic solvent. If necessary, use a brush to physically peel and clean off the residue more effectively.
- 2) Remove the locking adhesive from the female thread in the same way.  
Be careful to prevent the locking adhesive and dust from entering the sliding part.  
Do not wipe the grease off the guide.
- 3) Since organic solvent can be dangerous, refer to its MSDS and take appropriate measures for safe use.

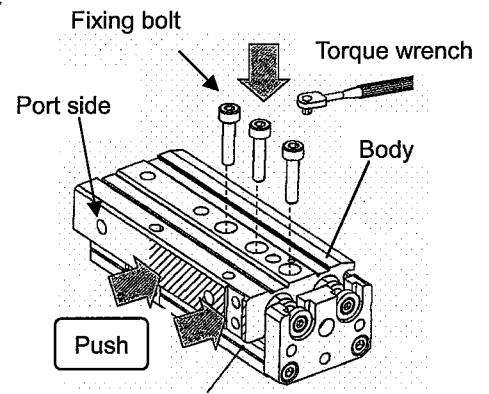
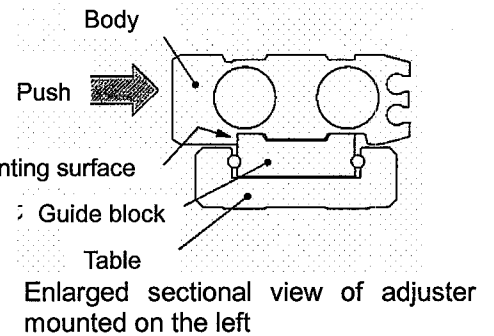

Adjuster mounted on the left (MXQR\*\*L type)

- (2) As shown in the figure on the right, push the body down to the reference mounting surface at the port side or auto switch mounting side (Table 1) and tighten it temporarily with the fixing bolts using a hexagon wrench. Then, tighten to the torque specified in Table 2 using a torque wrench or torque driver. The reference mounting surface has thin slits on the table side.

Table 1 Pushing force (referential value)

Bore size (mm)	Pushing force N
6	3 to 6
8	5 to 10
12	10 to 20
16	20 to 40
20	30 to 60
25	45 to 90

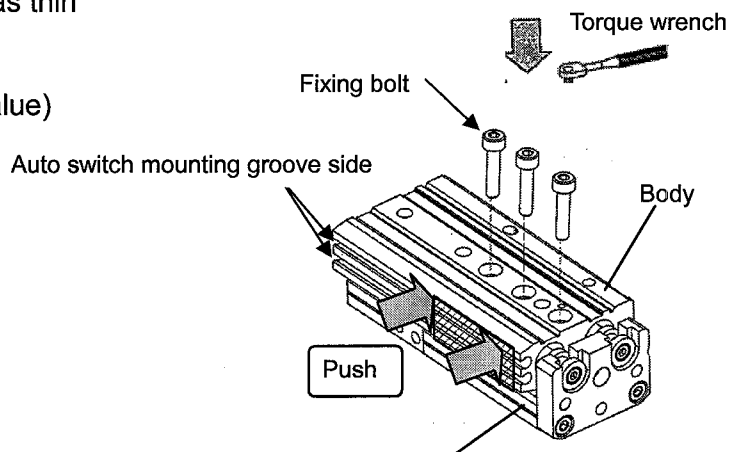

Adjuster mounted on the right (MXQR\*\* type)

**⚠ Caution**

**Tighten to the specified torque. Insufficient torque can cause accuracy failure and play at the guide. Excessive torque can cause deformation of parts, operating failure, and accuracy failure.**

Table 2 Tightening torque (for body)

Bore size (mm)	Thread size	Tightening torque (Nm)
6	M2.5	0.36
8	M3	0.63
12	M4	1.5
16	M5	3.0
20	M6	5.2
25	M8	12.5

- (3) Turn the floating part lightly and check there is no excessive resistance.

Note) When turning the floating part, use the wrench flat of the rod. If the rod is gripped by pliers, etc., air leakage can result. Since the MXQR6 and 8 do not have wrench flats, use the floating bushing instead.

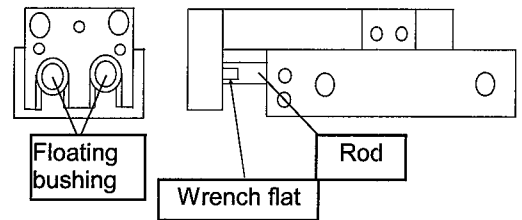

**4-5 Mounting accessories**

- (1) Mount the adjuster parts to the appropriate direction shown in the figure on the right.

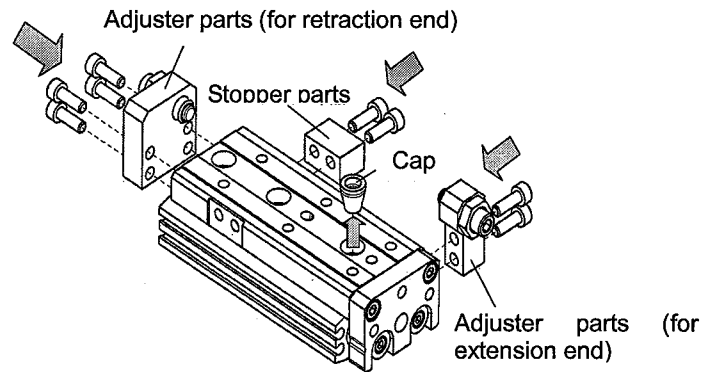

- (2) When assembling the adjuster parts (for extension end) and stopper parts, make sure there is no gap, as shown in the figure on the right.

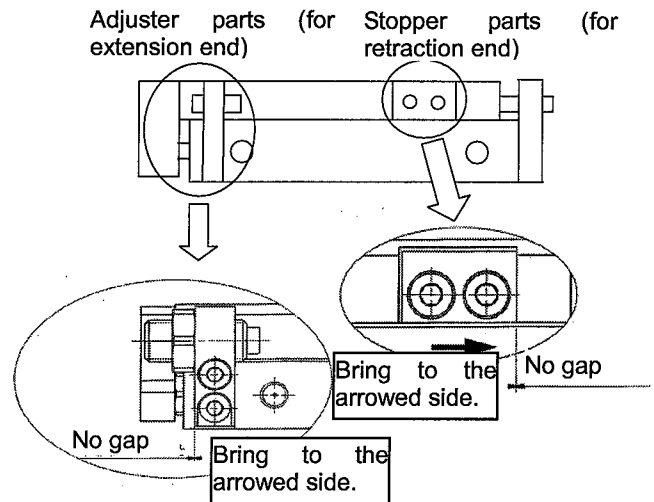

(3) Fix accessories (parts for adjuster and stopper) by tightening the fixing bolts to the torque specified in Table 2 using a torque wrench or torque driver.

Table 2 Tightening torque (for accessories)

Model	Mounting part of adjuster (for extension end) and stopper		Mounting part of adjuster (for retraction end)	
	Thread size	Tightening torque Nm	Thread size	Tightening torque Nm
MXQR 6	M2.5	0.5	M2.5	0.5
MXQR 8	M3	0.9	M3	0.9
MXQR12	M4	2.1	M4	2.1
MXQR16	M5	4.4	M5	4.4
MXQR20	M6	7.0		
MXQR25	M8	18.0	M6	7.0

#### 4-6 Completion of change

The adjuster has been changed from the left one to the right one as shown in the figure on the right.

\*The guide uses martensitic stainless steel.

Clean the product sufficiently to prevent generation of rust.

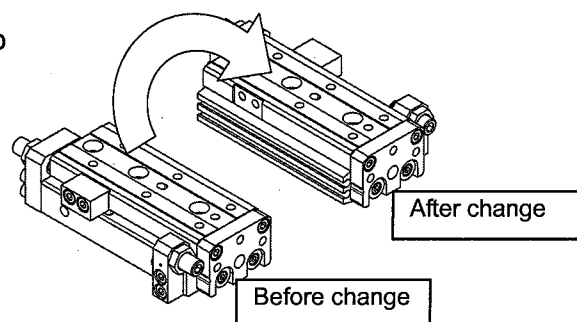

#### 4-7 Removal of cap

Remove the cap from the bottom of the body using a hexagon wrench as shown in the figure on the right.

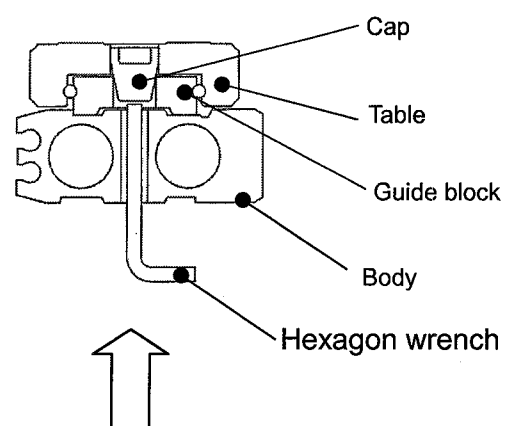

Revision history

## SMC Corporation

4-14-1, Sotokanda, Chiyoda-ku, Tokyo 101-0021 JAPAN

Tel: + 81 3 5207 8249 Fax: +81 3 5298 5362

URL <http://www.smcworld.com>

---

Note: Specifications are subject to change without prior notice and any obligation on the part of the manufacturer.  
© 2009 SMC Corporation All Rights Reserved