

Mechanically Jointed Rodless Cylinder

Series MY1



High Accuracy



Allowable moment Large



High rigidity/
Linear guide type
Series MY1HT

Linear guide type
Series MY1H

Cam follower guide type
Series MY1C

Slide bearing guide type
Series MY1M

Basic type
Series MY1B

- MY1B -Z
- MY1H -Z
- MY1B
- MY1M
- MY1C
- MY1H
- MY1 HT
- MY1 □W
- MY2C
- MY2 H□
- MY3A
- MY3B
- MY3M

Five types of guide allow a wide range of selections.

Series Variations		Piping type ⁽¹⁾	Bore size (mm)								Air cushion	Stroke adjustment Unit	Side support	Floating bracket	End lock	Made to Order ⁽³⁾	P. 1219	
Series	Guide type		10	16	20	25	32	40	50	63								80
MY1B	Basic type	Centralized piping Standard piping	●	●	●	●	●	●	●	●	●	●	●	●	●	●	P. 1263	
MY1M	Slide bearing guide type		●	●	●	●	●	●	●	●	●	●	●	●	●	●	●	P. 1283
MY1C	Cam follower guide type		●	●	●	●	●	●	●	●	●	●	●	●	●	●	●	P. 1307
MY1H	Linear guide type		●	●	●	●	●	●	●	●	●	●	●	●	●	●	●	
MY1HT	High rigidity/Linear guide type		●	●	●	●	●	●	●	●	●	●	●	●	●	●	●	

Note 1) $\phi 10$ is available with central piping only. Note 2) $\phi 10$ is available with rubber bumper only.
Note 3) Availability for Made-to-Order differs, depending on the size and the model.

- D-□
- X□

Technical data

Mechanically Jointed Rodless Cylinder

MY1 Series

Basic type

MY1B Series

Can be combined with a variety of guides to accommodate conditions. Simple design without guide facilitates space savings.

Basic type

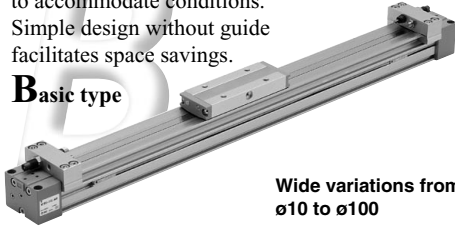

Wide variations from $\phi 10$ to $\phi 100$

Slide bearing type

MY1M Series

Integral guide allows use in a wide range of conveyor systems.

Moderate type

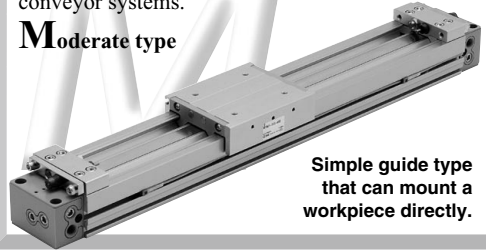

Simple guide type that can mount a workpiece directly.

Cam follower guide type

MY1C Series

Makes smooth operation possible even with an off-set load.

Cam follower type

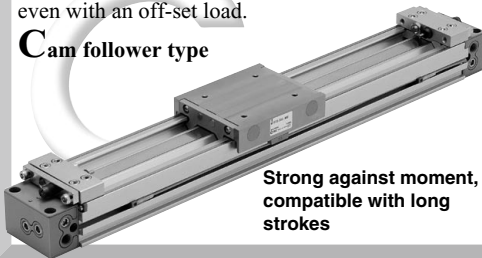

Strong against moment, compatible with long strokes

Linear guide type

MY1H Series

Small and medium sizes $\phi 10$ to $\phi 40$ are ideal for pick & place.

High precision type

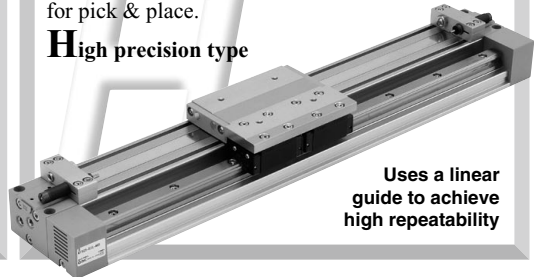

Uses a linear guide to achieve high repeatability

High rigidity/Linear guide type

MY1HT Series

Heavy load, high moment
Ideal for transfer and pick & place of heavy loaded workpieces

High precision Twin guide type



Linear guide
Heavy loaded workpieces can be accommodated by using two linear guides.

Stroke availability

Strokes may be selected in increments of 1 mm.

Stroke adjustment unit

Strokes can be adjusted either at one side or both sides.

- Adjustment bolt
- Low load shock absorber + Adjustment bolt (L unit)
- Heavy-loaded shock absorber + Adjustment bolt (H unit)

Centralized piping

Piping ports are concentrated at one side.

Side support

Side support prevents a cylinder tube from sagging in long stroke applications.

Interchangeability

The bodies and workpiece mountings are interchangeable between Series MY1M and MY1C.

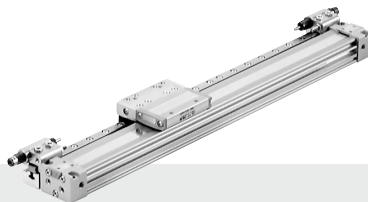
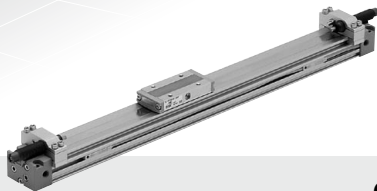

Basic type **MY1B10**

Height **27** mm

Linear guide type **MY1H10**



- Even when equipped with a floating bracket, the height is only 28.5 mm.

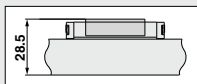

- The stroke adjustment unit (H unit) does not protrude above the table type.

- Stroke adjustment unit can be mounted
- Centralized piping type (Standard)

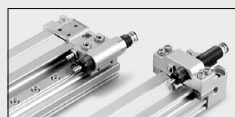

Uses two linear guides.
Maximum load mass of 320 kg. (ø63)

High rigidity/Linear guide type **MY1HT50/63**

Extremely easy to maintain

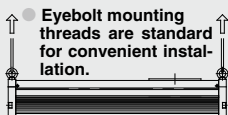

Using eyebolts

- It is possible to replace cylinders with a workpiece being mounted.

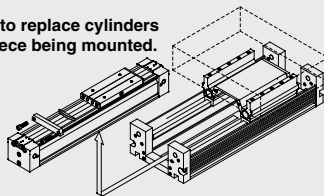

End lock type introduced to series **MY1H**.

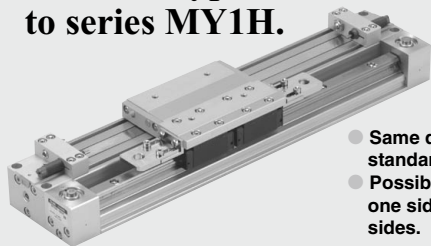

- Same dimensions as standard
- Possible to lock either on one side or on both sides.

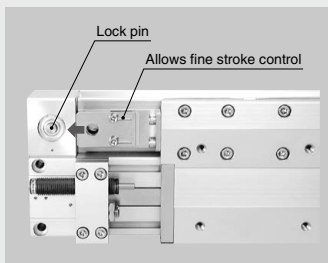

MY1B
-Z

MY1H
-Z

MY1B

MY1M

MY1C

MY1H

MY1
HT

MY1
□W

MY2C

MY2
H□

MY3A
MY3B

MY3M

D-□

-X□

Technical
data

Series MY1 Model Selection 1

Following are the steps for selecting the most suitable Series MY1 to your application.

Standards for Tentative Model Selection

Cylinder model	Guide type	Standards for guide selection	Graphs for related allowable values
MY1B	Basic type	Guaranteed accuracy not required, generally combined with separate guide	Refer to P. 1220.
MY1M	Slide bearing guide type	Slide table accuracy approx. ± 0.12 mm ⁽²⁾	Refer to P. 1244.
MY1C	Cam follower guide type	Slide table accuracy approx. ± 0.05 mm ⁽²⁾	Refer to P. 1264.
MY1H	Linear guide type	Slide table accuracy of ± 0.05 mm or less required ⁽²⁾	Refer to P. 1284.
MY1HT	High rigidity/Linear guide type	Slide table accuracy of ± 0.05 mm or less required ⁽²⁾	Refer to P. 1308.

Note 1) These accuracy values for each guide should be used only as a guide during selection. Please contact SMC when guaranteed accuracy for MY1C/MY1H is required.

Note 2) "Accuracy" here means displacement of the slide table (at stroke end) when 50% of the allowable moment shown in the catalog is applied. (reference value).

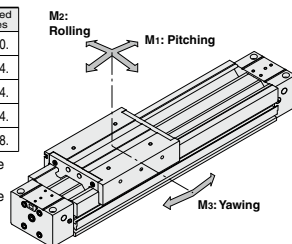

Selection Flow Chart

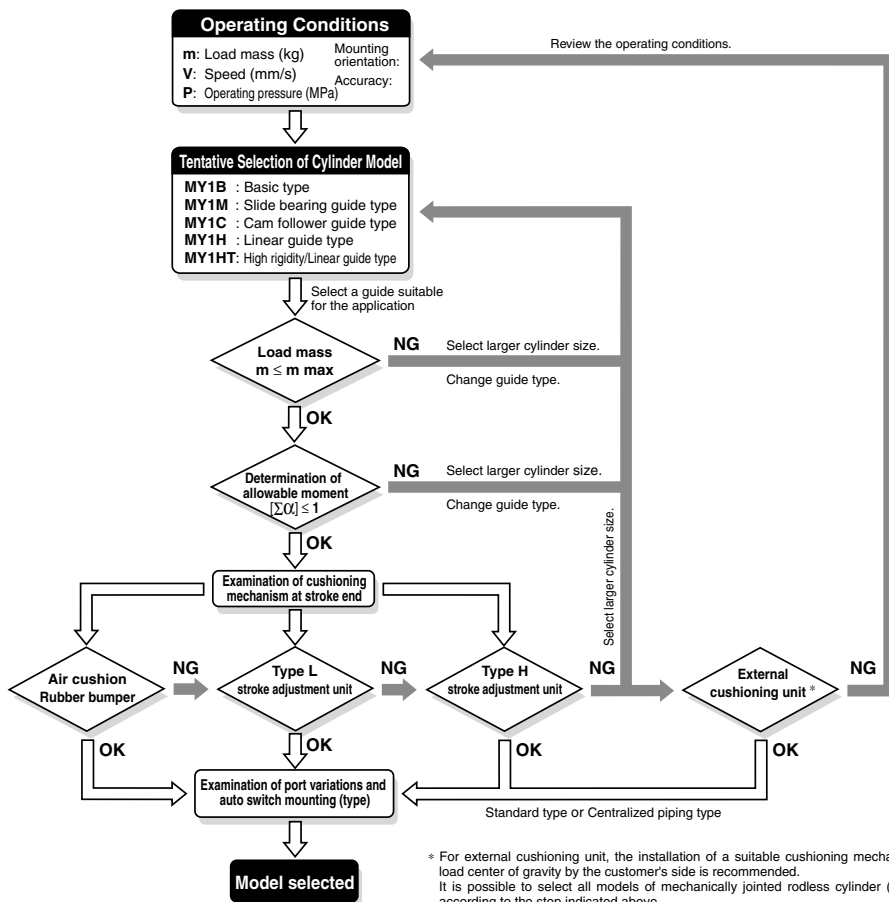

Types of Moment Applied to Rodless Cylinders

Multiple moments may be generated depending on the mounting orientation, load, and position of the center of gravity.

Coordinates and Moments

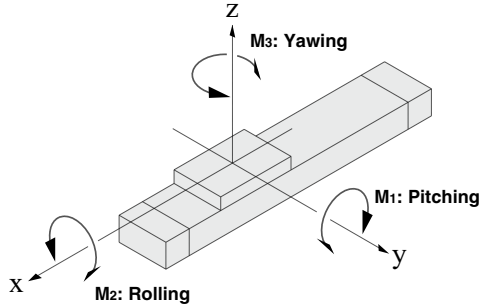

Static Moment

Horizontal mounting

Ceiling mounting

Wall mounting

Vertical mounting

g: Gravitational acceleration

Mounting orientation	Horizontal mounting	Ceiling mounting	Wall mounting	Vertical mounting
Static load (m)	m_1	m_2	m_3	m_4 (Note)
M_1	$m_1 \times g \times X$	$m_2 \times g \times X$	—	$m_4 \times g \times Z$
M_2	$m_1 \times g \times Y$	$m_2 \times g \times Y$	$m_3 \times g \times Z$	—
M_3	—	—	$m_3 \times g \times X$	$m_4 \times g \times Y$

Note) m_4 is a mass movable by thrust. Use 0.3 to 0.7 times the thrust (differs depending on the operating speed) as a guide for actual use.

Dynamic Moment

Mounting orientation	Horizontal mounting	Ceiling mounting	Wall mounting	Vertical mounting
Dynamic load (Fe)	$1.4 \times \nu_a \times \delta \times m_n \times g$			
M_{1E}	$\frac{1}{3} \times F_E \times Z$			
M_{2E}	Dynamic moment M_{2E} is not generated.			
M_{3E}	$\frac{1}{3} \times F_E \times Y$			

Note) Regardless of the mounting orientation, dynamic moment is calculated with the formulae above.

g: Gravitational acceleration, ν_a : Average speed, δ : Damper coefficient

- MY1B -Z
- MY1H -Z
- MY1B
- MY1M
- MY1C
- MY1H
- MY1 HT
- MY1 W
- MY2C
- MY2 H
- MY3A
- MY3B
- MY3M

- D-
- X
- Technical data

Series MY1 Model Selection 2

Following are the steps for selecting the most suitable Series MY1 to your application.

Calculation of Guide Load Factor

1. Operating Conditions

Operating cylinder MY1H40-500
Average operating speed v_a ... 300 mm/s
Mounting orientation Wall mounting
Cushion Air cushion ($\dot{O} = 1/100$)

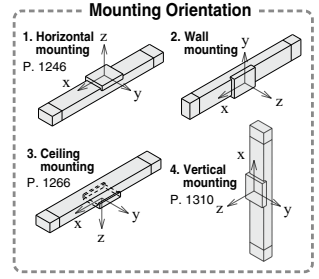
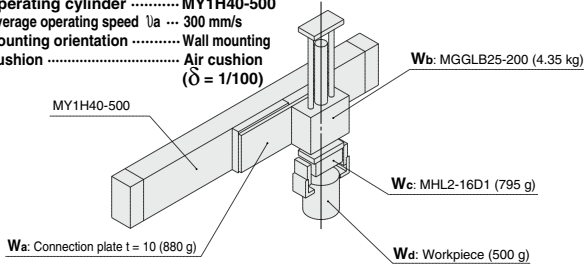

For actual examples of calculation for each orientation, refer to the pages above.

2. Load Blocking

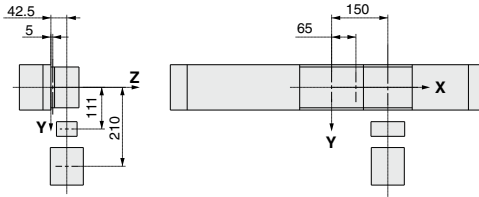

Mass and Center of Gravity for Each Workpiece

Workpiece no. W _n	Mass m _n	Center of gravity		
		X-axis X _n	Y-axis Y _n	Z-axis Z _n
W _a	0.88 kg	65 mm	0 mm	5 mm
W _b	4.35 kg	150 mm	0 mm	42.5 mm
W _c	0.795 kg	150 mm	111 mm	42.5 mm
W _d	0.5 kg	150 mm	210 mm	42.5 mm

n = a, b, c, d

3. Composite Center of Gravity Calculation

$$m_3 = \sum m_n \\ = 0.88 + 4.35 + 0.795 + 0.5 = 6.525 \text{ kg}$$

$$X = \frac{1}{m_3} \times \sum (m_n \times X_n) \\ = \frac{1}{6.525} (0.88 \times 65 + 4.35 \times 150 + 0.795 \times 150 + 0.5 \times 150) = 138.5 \text{ mm}$$

$$Y = \frac{1}{m_3} \times \sum (m_n \times Y_n) \\ = \frac{1}{6.525} (0.88 \times 0 + 4.35 \times 0 + 0.795 \times 111 + 0.5 \times 210) = 29.6 \text{ mm}$$

$$Z = \frac{1}{m_3} \times \sum (m_n \times Z_n) \\ = \frac{1}{6.525} (0.88 \times 5 + 4.35 \times 42.5 + 0.795 \times 42.5 + 0.5 \times 42.5) = 37.4 \text{ mm}$$

4. Calculation of Load Factor for Static Load

m₃: Mass

m₃ max (from (1) of graph MY1H/m₃) = 50 (kg)
Load factor $\alpha_1 = m_3/m_3 \text{ max} = 6.525/50 = 0.13$

M₂: Moment

M₂ max (from (2) of graph MY1H/M₂) = 50 (N·m)
M₂ = m₃ × g × Z = 6.525 × 9.8 × 37.4 × 10⁻³ = 2.39 (N·m)
Load factor $\alpha_2 = M_2/M_2 \text{ max} = 2.39/50 = 0.05$

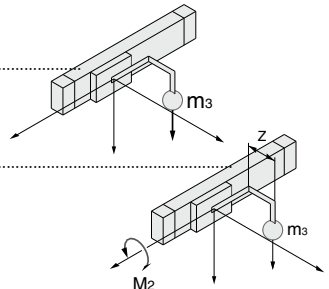

M₃: Moment

M₃ max (from (3) of graph MY1H/M₃) = 38.7 (N·m)

$$M_3 = m_3 \times g \times X = 6.525 \times 9.8 \times 138.5 \times 10^{-3} = 8.86 \text{ (N·m)}$$

$$\text{Load factor } \alpha_3 = M_3 / M_3 \text{ max} = 8.86 / 38.7 = 0.23$$

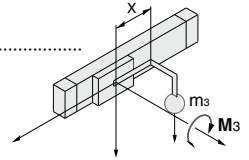

5. Calculation of Load Factor for Dynamic Moment

Equivalent load F_E at impact

$$F_E = 1.4Ua \times \delta \times m \times g = 1.4 \times 300 \times \frac{1}{100} \times 6.525 \times 9.8 = 268.6 \text{ (N)}$$

M_{1E}: Moment

M_{1E} max (from (4) of graph MY1H/M₁ where 1.4Ua = 420 mm/s) = 35.9 (N·m)

$$M_{1E} = \frac{1}{3} \times F_E \times Z = \frac{1}{3} \times 268.6 \times 37.4 \times 10^{-3} = 3.35 \text{ (N·m)}$$

$$\text{Load factor } \alpha_4 = M_{1E} / M_{1E} \text{ max} = 3.35 / 35.9 = 0.09$$

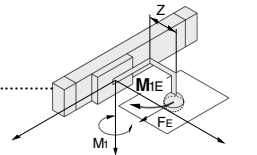

M_{3E}: Moment

M_{3E} max (from (5) of graph MY1H/M₃ where 1.4Ua = 420 mm/s) = 27.6 (N·m)

$$M_{3E} = \frac{1}{3} \times F_E \times Y = \frac{1}{3} \times 268.6 \times 29.6 \times 10^{-3} = 2.65 \text{ (N·m)}$$

$$\text{Load factor } \alpha_5 = M_{3E} / M_{3E} \text{ max} = 2.65 / 27.6 = 0.10$$

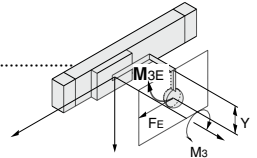

6. Sum and Examination of Guide Load Factors

$$\Sigma \alpha = \alpha_1 + \alpha_2 + \alpha_3 + \alpha_4 + \alpha_5 = 0.60 \leq 1$$

The above calculation is within the allowable value, and therefore the selected model can be used.

Select a shock absorber separately.

In an actual calculation, when the sum of guide load factors α in the formula above is more than 1, consider decreasing the speed, increasing the bore size, or changing the product series.

This calculation can be easily made using the “SMC Pneumatics CAD System”.

- MY1B -Z
- MY1H -Z
- MY1B
- MY1M
- MY1C
- MY1H
- MY1 HT
- MY1 □W
- MY2C
- MY2 □H
- MY3A
- MY3B
- MY3M

Load Mass

MY1H/m₃

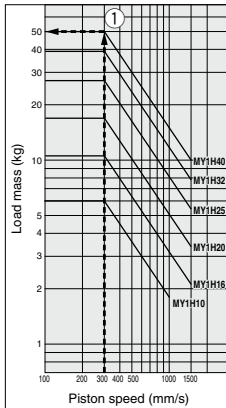

Allowable Moment

MY1H/M₁

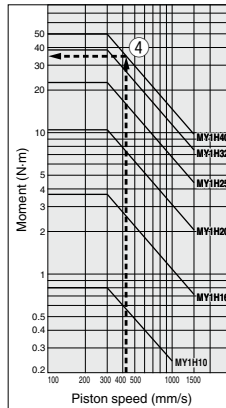

MY1H/M₂

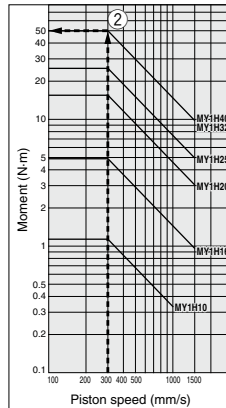

MY1H/M₃

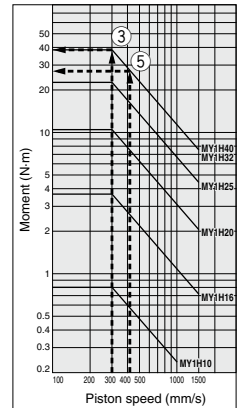

- D-□
- X□
- Technical data

Series MY1B

Basic Type

ø10, ø16, ø20, ø25, ø32, ø40, ø50, ø63, ø80, ø100

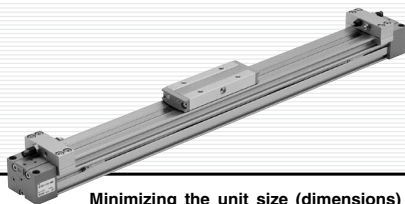

Minimizing the unit size (dimensions) and combination with other guides is possible.

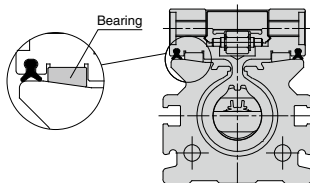

MY1B
-Z

MY1H
-Z

MY1B

MY1M

MY1C

MY1H

MY1
HT

MY1
□W

MY2C

MY2
H□

MY3A
MY3B

MY3M

D-□

-X□

Technical
data

Series MY1B Prior to Use

Maximum Allowable Moment/Maximum Load Mass

Model	Bore size (mm)	Maximum allowable moment (N·m)			Maximum load mass (kg)		
		M1	M2	M3	m1	m2	m3
MY1B	10	0.8	0.1	0.3	5.0	1.0	0.5
	16	2.5	0.3	0.8	15	3.0	1.7
	20	5.0	0.6	1.5	21	4.2	3.0
	25	10	1.2	3.0	29	5.8	5.4
	32	20	2.4	6.0	40	8.0	8.8
	40	40	4.8	12	53	10.6	14
	50	78	9.3	23	70	14	20
	63	160	19	48	83	16.6	29
	80	315	37	95	120	24	42
	100	615	73	184	150	30	60

The above values are the maximum allowable values for moment and load. Refer to each graph regarding the maximum allowable moment and maximum allowable load for a particular piston speed.

Caution on Design

We recommend installing an external shock absorber when the cylinder is combined with another guide (connection with floating bracket, etc.) and the maximum allowable load is exceeded, or when the operating speed is 1000 to 1500 mm/s for bore sizes ø16, ø50, ø63, ø80 and ø100.

Load mass (kg)

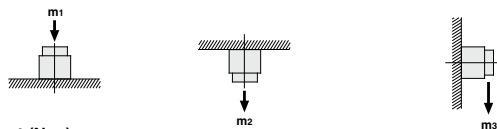

Moment (N·m)

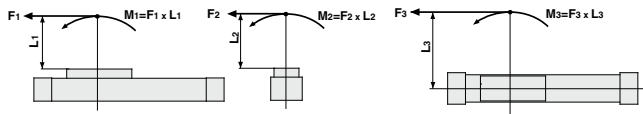

<Calculation of guide load factor>

- Maximum allowable load (1), static moment (2), and dynamic moment (3) (at the time of impact with stopper) must be examined for the selection calculations.
 - To evaluate, use \bar{U}_a (average speed) for (1) and (2), and U (collision speed $U = 1.4 \bar{U}_a$) for (3). Calculate m_{max} for (1) from the maximum allowable load graph (m_1, m_2, m_3) and M_{max} for (2) and (3) from the maximum allowable moment graph (M_1, M_2, M_3).

$$\text{Sum of guide load factors } \sum \alpha = \frac{\text{Load mass [m]}}{\text{Maximum allowable load [m}_{max}\text{]}} + \frac{\text{Static moment [M]}^{(1)}}{\text{Allowable static moment [M}_{max}\text{]}} + \frac{\text{Dynamic moment [M}_E\text{]}^{(2)}}{\text{Allowable dynamic moment [M}_{Emax}\text{]}} \leq 1$$

- Note 1) Moment caused by the load, etc., with cylinder in resting condition.
 Note 2) Moment caused by the impact load equivalent at the stroke end (at the time of impact with stopper).
 Note 3) Depending on the shape of the workpiece, multiple moments may occur. When this happens, the sum of the load factors ($\sum \alpha$) is the total of all such moments.

2. Reference formula [Dynamic moment at impact]

Use the following formulae to calculate dynamic moment when taking stopper impact into consideration.

- m : Load mass (kg)
- F : Load (N)
- F_E : Load equivalent to impact (at impact with stopper) (N)
- \bar{U}_a : Average speed (mm/s)
- M : Static moment (N·m)
- $U = 1.4 \bar{U}_a$ (mm/s) $F_E = 1.4 \bar{U}_a \cdot \delta \cdot m \cdot g$
- $\therefore M_E = \frac{1}{3} F_E \cdot L = 4.57 \bar{U}_a \delta m L$
- U : Collision speed (mm/s)
- L : Distance to the load's center of gravity (m)
- M_E : Dynamic moment (N·m)
- δ : Damper coefficient
- With rubber bumper = 4/100 (MY1B10, MY1H10)
- With air cushion = 1/100
- With shock absorber = 1/100
- g : Gravitational acceleration (9.8 m/s²)

- Note 4) $1.4 \bar{U}_a \delta$ is a dimensionless coefficient for calculating impact force.
 Note 5) Average load coefficient ($= \frac{1}{3}$): This coefficient is for averaging the maximum load moment at the time of stopper impact according to service life calculations.

- For detail selection procedures, refer to pages 1222 and 1223.

Maximum Allowable Moment

Select the moment from within the range of operating limits shown in the graphs. Note that the maximum allowable load value may sometimes be exceeded even within the operating limits shown in the graphs. Therefore, also check the allowable load for the selected conditions.

Maximum Load Mass

Select the load from within the range of limits shown in the graphs. Note that the maximum allowable moment value may sometimes be exceeded even within the operating limits shown in the graphs. Therefore, also check the allowable moment for the selected conditions.

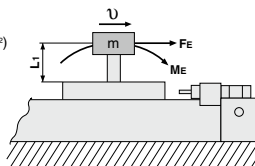

MY1B/M₁

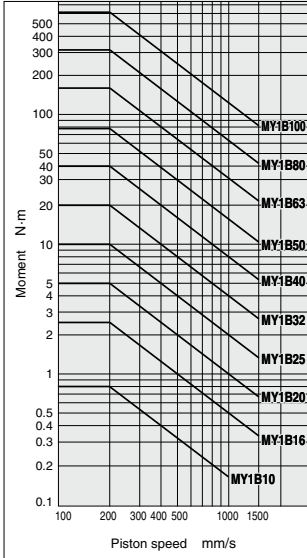

MY1B/M₂

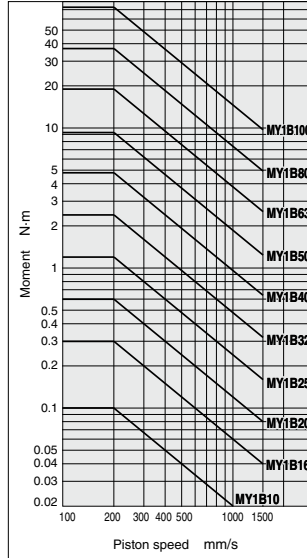

MY1B/M₃

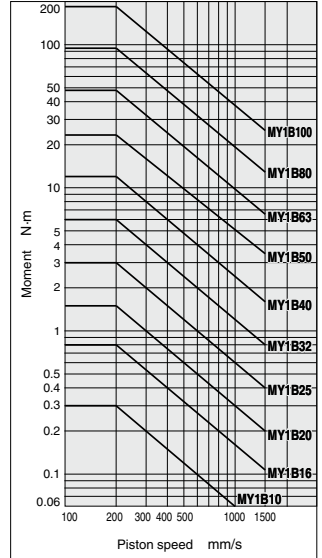

MY1B/m₁

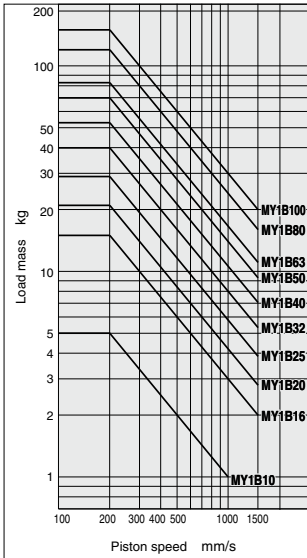

MY1B/m₂

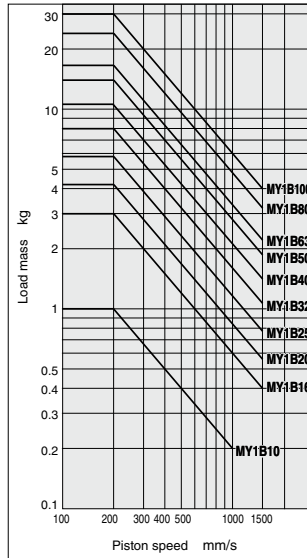

MY1B/m₃

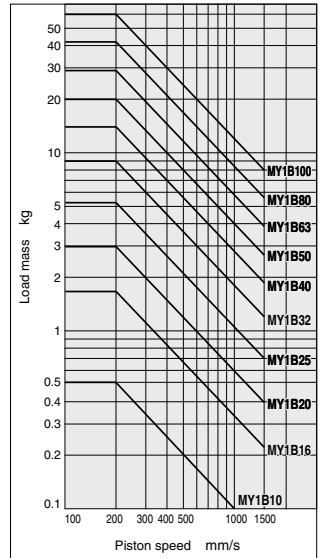

MY1B
-Z

MY1H
-Z

MY1B

MY1M

MY1C

MY1H

MY1
HT

MY1
□W

MY2C

MY2
H□

MY3A

MY3B

MY3M

D-□

-X□

Technical
data

Series MY1B Model Selection

Following are the steps for selecting the most suitable Series MY1B to your application.

Calculation of Guide Load Factor

1. Operating Conditions

Cylinder MY1B32-500
 Average operating speed \bar{v}_a ... 300 mm/s
 Mounting orientation Horizontal mounting
 Cushion Air cushion
 ($\bar{\delta} = 1/100$)

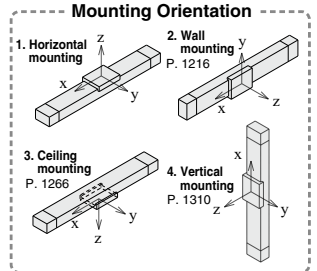
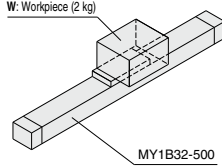

For actual examples of calculation for each orientation, refer to the pages above.

2. Load Blocking

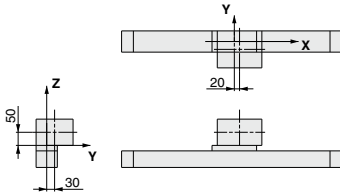

Mass and Center of Gravity for Workpiece

Workpiece no.	Mass m	Center of gravity		
		X-axis	Y-axis	Z-axis
W	2 kg	20 mm	30 mm	50 mm

3. Calculation of Load Factor for Static Load

m₁: Mass

m₁ max (from (1) of graph MY1B/**m₁**) = 27 (kg).....

Load factor $\alpha_1 = m_1 / m_1 \text{ max} = 2/27 = 0.07$

M₁: Moment

M₁ max (from (2) of graph MY1B/**M₁**) = 13 (N·m).....

M₁ = **m₁** × **g** × **X** = 2 × 9.8 × 20 × 10⁻³ = 0.39 (N·m)

Load factor $\alpha_2 = M_1 / M_1 \text{ max} = 0.39/13 = 0.03$

M₂: Moment

M₂ max (from (3) of graph MY1B/**M₂**) = 1.6 (N·m).....

M₂ = **m₁** × **g** × **Y** = 2 × 9.8 × 30 × 10⁻³ = 0.59 (N·m)

Load factor $\alpha_3 = M_2 / M_2 \text{ max} = 0.59/1.6 = 0.37$

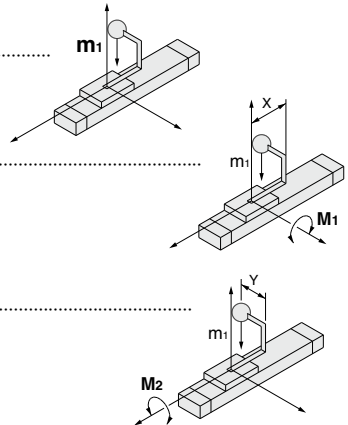

4. Calculation of Load Factor for Dynamic Moment

Equivalent load F_E at impact

$$F_E = 1.4Ua \times \delta \times m \times g = 1.4 \times 300 \times \frac{1}{100} \times 2 \times 9.8 = 82.3 \text{ (N)}$$

M_{1E} : Moment

$M_{1E} \text{ max}$ (from (1) of graph MY1B/ M_1 where $1.4Ua = 420 \text{ mm/s}$) = 9.5 (N·m).....

$$M_{1E} = \frac{1}{3} \times F_E \times Z = \frac{1}{3} \times 82.3 \times 50 \times 10^{-3} = 1.37 \text{ (N·m)}$$

Load factor $\alpha_4 = M_{1E}/M_{1E} \text{ max} = 1.37/9.5 = 0.14$

M_{3E} : Moment

$M_{3E} \text{ max}$ (from (5) of graph MY1B/ M_3 where $1.4Ua = 420 \text{ mm/s}$) = 2.9 (N·m).....

$$M_{3E} = \frac{1}{3} \times F_E \times Y = \frac{1}{3} \times 82.3 \times 30 \times 10^{-3} = 0.82 \text{ (N·m)}$$

Load factor $\alpha_5 = M_{3E}/M_{3E} \text{ max} = 0.82/2.9 = 0.28$

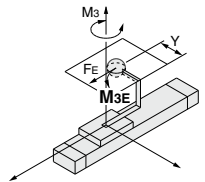
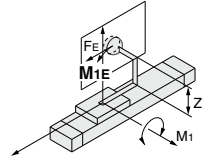

5. Sum and Examination of Guide Load Factors

$$\Sigma\alpha = \alpha_1 + \alpha_2 + \alpha_3 + \alpha_4 + \alpha_5 = 0.89 \leq 1$$

The above calculation is within the allowable value, and therefore the selected model can be used. Select a shock absorber separately.

In an actual calculation, when the total sum of guide load factors α in the formula above is more than 1, consider either decreasing the speed, increasing the bore size, or changing the product series. This calculation can be easily made using the "SMC Pneumatics CAD System".

MY1B

-Z

MY1H

-Z

MY1B

MY1M

MY1C

MY1H

MY1 HT

MY1

W

MY2C

MY2

H

MY3A

MY3B

MY3M

Load Mass

MY1B/ m_1

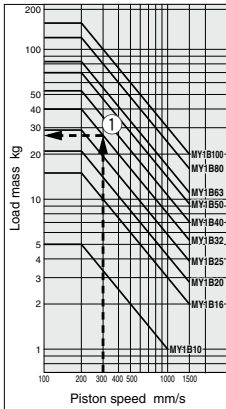

Allowable Moment

MY1B/ M_1

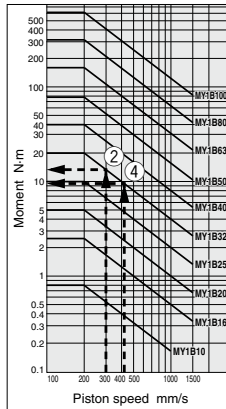

MY1B/ M_2

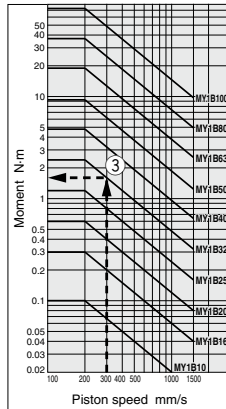

MY1B/ M_3

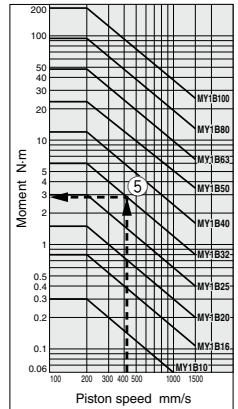

D-□

-X□

Technical data

Mechanically Jointed Rodless Cylinder Basic Type

Series MY1B

ø10, ø16, ø20, ø25, ø32, ø40, ø50, ø63, ø80, ø100

Series MY1B basic type ø25, ø32, and ø40 sizes have been remodeled with a reduction in weight and improved piping flexibility. Refer to page1170 for details.

How to Order

Basic type MY1B 20 - 300 - M9BW

Bore size (mm)

10	10 mm
16	16 mm
20	20 mm
25	25 mm
32	32 mm
40	40 mm
50	50 mm
63	63 mm
80	80 mm
100	100 mm

Basic type

Port thread type

Symbol	Type	Bore size
Nil	M thread	ø10, ø16, ø20
	Rc	ø25, ø32, ø40, ø50, ø63, ø80, ø100
TN	NPT	
TF	G	

Piping

Nil	Standard type
G	Centralized piping type

Note) For ø10, only G is available.

Cylinder stroke (mm)

Bore size (mm)	Standard stroke (mm)*	Maximum manufacturable stroke (mm)
10, 16	100, 200, 300, 400, 500, 600, 700	3000
20, 25, 32, 40	800, 900, 1000, 1200, 1400, 1600	5000
50, 63, 80, 100	1800, 2000	

* The stroke can be manufactured up to the maximum stroke from 1 mm stroke in 1 mm increments. However, when the stroke is 49 mm or less, the air cushion capability lowers and multiple auto switches cannot be mounted. Pay special attention to this point. Also when exceeding a 2000 mm stroke, specify "XB11" at the end of the model number. For details, refer to the "Made to Order Specifications"

Made to Order
Refer to page 1225 for details.

Number of auto switches

Nil	2 pcs.
S	1 pc.
n	"n" pcs.

Auto switch

Nil Without auto switch (Built-in magnet)

For ø10 cylinders without an auto switch, the cylinder configuration is for the reed auto switch. Contact SMC when the solid state auto switch is retrofitted.

Applicable auto switches vary depending on the bore size. Select an applicable one referring to the table below.

Stroke adjustment unit symbol

Refer to "Stroke adjustment unit" on page 1225.

Applicable Auto Switches

Refer to pages 1559 to 1673 for further information on auto switches.

Type	Special function	Electrical entry	Indicator light	Wiring (Output)	Load voltage		Auto switch model		Lead wire length (m)				Pre-wired connector	Applicable load	
					DC	AC	Perpendicular ø10 to ø20 [Y69A]	In-line ø10 to ø20 [Y59A]	0.5 (Nil)	1 (M)	3 (L)	5 (Z)			
															DC
Solid state auto switch	—	Grommet	Yes	3-wire (NPN)	5 V, 12 V	—	M9NV** [Y69A]	M9N** [Y59A]	●	●	○	○	IC circuit	Relay, PLC	
				3-wire (PNP)			M9PV** [Y7P]	M9P** [Y7P]	●	●	○	○			
				2-wire	M9BV** [Y69B]		M9B** [Y59B]	●	●	○	○	—			
				3-wire (NPN)	M9NWV** [Y7NWV]		M9NW** [Y7NW]	●	●	○	○	IC circuit			
				3-wire (PNP)	M9PWV** [Y7PWV]		M9PW** [Y7PW]	●	●	○	○				
				2-wire	M9BWB** [Y7BWV]		M9BW** [Y7BW]	●	●	○	○	—			
	Diagnostic indication (2-color indication)	Grommet	Yes	3-wire (NPN)	24 V	—	M9NAV*** [—]	M9NA*** [—]	○	○	●	○	IC circuit	—	
				3-wire (PNP)			M9PAV*** [—]	M9PA*** [—]	○	○	●	○			
				2-wire	M9BVA*** [—]		M9BA*** [Y7BA]	○	○	●	○	—			
				3-wire (NPN)	M9NAV*** [—]		M9NA*** [—]	○	○	●	○	IC circuit			
				3-wire (PNP)	M9PAV*** [—]		M9PA*** [—]	○	○	●	○				
				2-wire	M9BVA*** [—]		M9BA*** [Y7BA]	○	○	●	○	—			
Water resistant (2-color indication)	Grommet	Yes	3-wire (NPN)	5 V, 12 V	—	M9NAV*** [—]	M9NA*** [—]	○	○	●	○	IC circuit	—		
			3-wire (PNP)			M9PAV*** [—]	M9PA*** [—]	○	○	●	○				
Reed auto switch	—	Grommet	Yes	3-wire (NPN equivalent)	—	5 V	A96V	A96	Z76	●	—	●	—	IC circuit	—
				2-wire			24 V	12 V	A93V 100 V or less	A93	Z73	●	—	●	—
			No	2-wire	24 V	12 V	A90V	A90	Z80	●	—	●	—	IC circuit	—

*** Water resistant type auto switches can be mounted on the above models, but in such case SMC cannot guarantee water resistance. Consult with SMC regarding water resistant types with the above model numbers.

* Lead wire length symbols: 0.5 m Nil (Example) M9NW
1 m M (Example) M9NWM
3 m L (Example) M9NWL
5 m Z (Example) M9NWZ

* Solid state auto switches marked with "○" are produced upon receipt of order.
* Separate switch spacers (BMG2-012) are required to retrofit auto switches (M9 type) on cylinders ø25 to ø40, ø63 to ø100
** D-M9□□□ type cannot be mounted on ø50. Select auto switches in brackets.

* There are other applicable auto switches than listed above. For details, refer to page 1321.

* For details about auto switches with pre-wired connector, refer to pages 1626 and 1627.

* Auto switches are shipped together (not assembled).

Mechanically Jointed Rodless Cylinder Basic Type **Series MY1B**

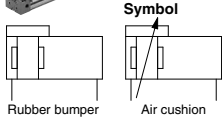
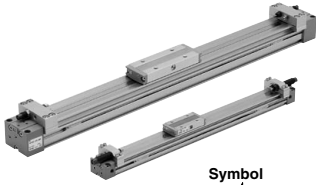

Made to Order

Made to Order: Individual Specifications
(For details, refer to page 1322.)

Symbol	Specifications
-X168	Helical insert thread specifications

Made to Order Specifications
(For details, refer to pages 1699 to 1818.)

Symbol	Specifications
-XB11	Long stroke type
-XB22	Shock absorber soft type Series RJ type
-XC67	NBR rubber lining in dust seal band

Specifications

Bore size (mm)	10	16	20	25	32	40	50	63	80	100
Fluid	Air									
Action	Double acting									
Operating pressure range	0.2 to 0.8 MPa					0.1 to 0.8 MPa				
Proof pressure	1.2 MPa									
Ambient and fluid temperature	5 to 60°C									
Cushion	Rubber bumper					Air cushion				
Lubrication	Non-lube									
Stroke length tolerance	1000 or less $+^{1}_{0}$ 1001 to 3000 $+^{2}_{0}$					2700 or less $+^{1}_{0}$ 2701 to 5000 $+^{2}_{0}$				
Piping Port size	Front/Side port	M5 x 0.8			Rc 1/8	Rc 1/4	Rc 3/8	Rc 1/2		
	Bottom port	ø4			ø6	ø8	ø10	ø18		

Piston Speed

Bore size (mm)		10	16 to 100
Without stroke adjustment unit		100 to 500 mm/s	100 to 1000 mm/s
Stroke adjustment unit	A unit	100 to 200 mm/s	100 to 1000 mm/s ⁽¹⁾
	L unit and H unit	100 to 1000 mm/s	100 to 1500 mm/s ⁽²⁾

Note1) Be aware that when the stroke adjustment range is increased by manipulating the adjustment bolt, the air cushion capacity decreases. Also, when exceeding the air cushion stroke ranges on page 1228, the piston speed should be 100 to 200 mm per second.

Note2) The piston speed is 100 to 1000 mm/s for centralized piping.

Note3) Use at a speed within the absorption capacity range. Refer to page 1227.

Stroke Adjustment Unit Specifications

Bore size (mm)		10	16	20	25	32	40						
Unit symbol		A	H	A	A	L	H	A	L	H	A	L	H
Configuration Shock absorber model		With adjustment bolt	RB 0805 + with adjustment bolt	With adjustment bolt	With adjustment bolt	RB 0806 + with adjustment bolt	RB 1007 + with adjustment bolt	With adjustment bolt	RB 1007 + with adjustment bolt	RB 1412 + with adjustment bolt	With adjustment bolt	RB 1412 + with adjustment bolt	RB 2015 + with adjustment bolt
Stroke adjustment range by intermediate fixing spacer (mm)	Without spacer	0 to -5	0 to -5.6	0 to -6	0 to -6	0 to -6	0 to -6	0 to -11.5	0 to -11.5	0 to -11.5	0 to -12	0 to -12	0 to -16
	With short spacer	—	-5.6 to -11.2	-6 to -12	-6 to -12	-6 to -12	-6 to -12	-11.5 to -23	-11.5 to -23	-11.5 to -23	-12 to -24	-12 to -24	-16 to -32
	With long spacer	—	-11.2 to -16.8	-12 to -18	-12 to -18	-12 to -18	-12 to -18	-23 to -34.5	-23 to -34.5	-23 to -34.5	-24 to -36	-24 to -36	-32 to -48

Note) Intermediate fixing spacer is not available for ø10.

* Stroke adjustment range is applicable for one side when mounted on a cylinder.

Stroke Adjustment Unit Symbol

		Right side stroke adjustment unit													
		Without unit		A: With adjustment bolt				L: With low load shock absorber + Adjustment bolt				H: With high load shock absorber + Adjustment bolt			
Left side stroke adjustment unit	Without unit	Nil	SA	SA6	SA7	SL	SL6	SL7	SH	SH6	SH7				
	A: With adjustment bolt	AS	A	AA6	AA7	AL	AL6	AL7	AH	AH6	AH7				
	With short spacer	A6S	A6A	A6	A6A7	A6L	A6L6	A6L7	A6H	A6H6	A6H7				
	With long spacer	A7S	A7A	A7A6	A7	A7L	A7L6	A7L7	A7H	A7H6	A7H7				
	L: With low load shock absorber + Adjustment bolt	LS	LA	LA6	LA7	L	LL6	LL7	LH	LH6	LH7				
	With short spacer	L6S	L6A	L6A6	L6A7	L6L	L6L6	L6L7	L6H	L6H6	L6H7				
	With long spacer	L7S	L7A	L7A6	L7A7	L7L	L7L6	L7L7	L7H	L7H6	L7H7				
	H: With high load shock absorber + Adjustment bolt	HS	HA	HA6	HA7	HL	HL6	HL7	H	HH6	HH7				
With short spacer	H6S	H6A	H6A6	H6A7	H6L	H6L6	H6L7	H6H	H6H6	H6H7					
With long spacer	H7S	H7A	H7A6	H7A7	H7L	H7L6	H7L7	H7H	H7H6	H7H7					

* Spacers are used to fix the stroke adjustment unit at an intermediate stroke position.

Shock Absorbers for L and H Units

Model	Stroke adjustment unit	Bore size (mm)				
		10	20	25	32	40
Standard (Shock absorber/RB series)	L	—	RB0806	RB1007	RB1412	—
	H	RB0805	RB1007	RB1412	RB2015	—
Shock absorber/soft type RJ series mounted (-XB22)	L	—	RJ0806H	RJ1007H	RJ1412H	—
	H	RJ0805	RJ1007H	RJ1412H	—	—

* The shock absorber service life is different from that of the MY1B cylinder depending on operating conditions. Refer to the RB Series Specific Product Precautions for the replacement period.

* Mounted shock absorber soft type RJ series (-XB22) is made to order specifications. For details, refer to page 1722.

Shock Absorber Specifications

Model	RB 0805	RB 0806	RB 1007	RB 1412	RB 2015	
Max. energy absorption (J)	1.0	2.9	5.9	19.6	58.8	
Stroke absorption (mm)	5	6	7	12	15	
Max. collision speed (mm/s)	1000	1500	1500	1500	1500	
Max. operating frequency (cycle/min)	80	80	70	45	25	
Spring force (N)	Extended	1.96	1.96	4.22	6.86	8.34
	Retracted	3.83	4.22	6.86	15.98	20.50
Operating temperature range (°C)	5 to 60					

* The shock absorber service life is different from that of the MY1B cylinder depending on operating conditions. Refer to the RB Series Specific Product Precautions for the replacement period.

Stroke adjustment unit mounting diagram

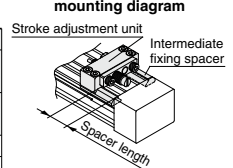

Example of H6H7 attachment

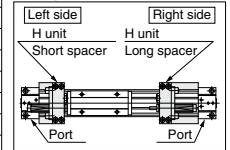

Series MY1B

Theoretical Output

Bore size (mm)	Piston area (mm ²)	Operating pressure (MPa)							
		0.2	0.3	0.4	0.5	0.6	0.7	0.8	
10	78	15	23	31	39	46	54	62	
16	200	40	60	80	100	120	140	160	
20	314	62	94	125	157	188	219	251	
25	490	98	147	196	245	294	343	392	
32	804	161	241	322	402	483	563	643	
40	1256	251	377	502	628	754	879	1005	
50	1962	392	588	784	981	1177	1373	1569	
63	3115	623	934	1246	1557	1869	2180	2492	
80	5024	1004	1507	2009	2512	3014	3516	4019	
100	7850	1570	2355	3140	3925	4710	5495	6280	

Note) Theoretical output (N) = Pressure (MPa) x Piston area (mm²)

Weight

Bore size (mm)	Basic weight	Additional weight per each 50 mm of stroke	Weight of moving parts	Stroke adjustment unit weight (per unit)			
				Side support bracket weight (per set)	A unit weight	L unit weight	H unit weight
10	0.15	0.04	0.03	0.003	0.01	—	0.02
16	0.61	0.06	0.07	0.01	0.04	—	—
20	1.06	0.10	0.14	0.02	0.05	0.05	0.10
25	1.33	0.12	0.21	0.02	0.06	0.10	0.18
32	2.65	0.18	0.47	0.02	0.12	0.21	0.40
40	3.87	0.27	0.91	0.04	0.23	0.32	0.49
50	7.78	0.44	1.40	0.04	—	—	—
63	13.10	0.70	2.20	0.08	—	—	—
80	20.70	1.18	4.80	0.17	—	—	—
100	35.70	1.97	8.20	0.17	—	—	—

Calculation: (Example) MY1B25-300A

- Basic weight 1.33 kg
- Cylinder stroke 300 stroke
- Additional weight 0.12/50 stroke
- $1.33 + 0.12 \times 300/50 + 0.06 \times 2 \approx 2.17$ kg
- Weight of A unit 0.06 kg

Option

Stroke Adjustment Unit Part No.

MY - A 25 L2 - 6N

Stroke adjustment unit

Bore size	
10	10 mm
16	16 mm
20	20 mm
25	25 mm
32	32 mm
40	40 mm

Note) Stroke adjustment unit is not available for ø50, ø63, ø80 and ø100.

Unit no.

Symbol	Stroke adjustment unit	Mounting position
A1	A unit	Left
A2	A unit	Right
L1	L unit	Left
L2	L unit	Right
H1	H unit	Left
H2	H unit	Right

Note 1) Refer to page 1225 for details about adjustment range.

Note 2) A and H unit only for ø10, A unit only for ø16

Intermediate fixing spacer

Nil	Without spacer
6	Short spacer
7	Long spacer

Spacer delivery style

Nil	Unit installed
N	Spacer only

* Spacers are used to fix the stroke adjustment unit at an intermediate stroke position.

* Spacers are shipped for a set of two.

Note) Intermediate fixing spacer is not available for ø10.

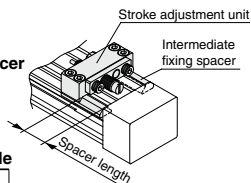

Component Parts

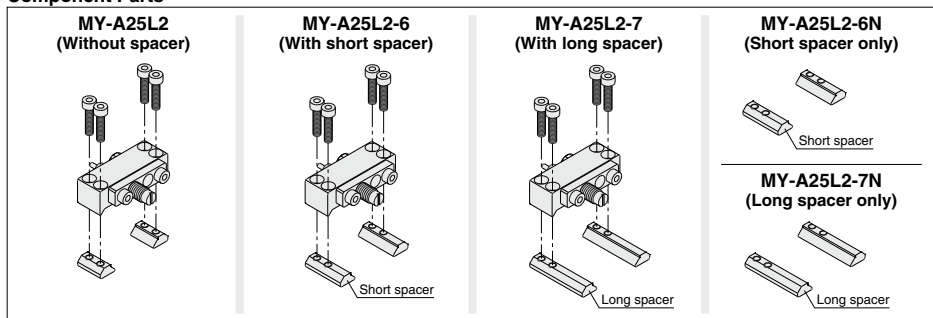

Side Support Part No.

Type \ Bore size (mm)	10	16	20	25	32	40	50	63	80	100
Side support A	MY-S10A	MY-S16A	MY-S20A	MY-S25A	MY-S32A	MY-S40A	MY-S50A	MY-S63A	MY-S80A	MY-S100A
Side support B	MY-S10B	MY-S16B	MY-S20B	MY-S25B	MY-S32B	MY-S40B	MY-S50B	MY-S63B	MY-S80B	MY-S100B

For details about dimensions, etc., refer to page 1239.

A set of side supports consists of a left support and a right support.

Cushion Capacity

Cushion Selection

<Rubber bumper>

Rubber bumpers are a standard feature on MY1B10.

Since the stroke absorption of rubber bumpers is short, when adjusting the stroke with an A unit, install an external shock absorber.

The load and speed range which can be absorbed by a rubber bumper is inside the rubber bumper limit line of the graph.

<Air cushion>

Air cushions are a standard feature on mechanically jointed rodless cylinders. (Except $\phi 10$.)

The air cushion mechanism is incorporated to prevent excessive impact of the piston at the stroke end during high speed operation. The purpose of air cushion, thus, is not to decelerate the piston near the stroke end.

The ranges of load and speed that air cushions can absorb are within the air cushion limit lines shown in the graphs.

<Stroke adjustment unit with shock absorber>

Use this unit when operating with a load or speed exceeding the air cushion limit line, or when cushioning is required outside of the effective air cushion stroke range due to stroke adjustment.

L unit

Use this unit when cushioning is necessary outside of the effective air cushion range even if the load and speed are within the air cushion limit line, or when the cylinder is operated in a load and speed range above the air cushion limit line and below the L unit limit line.

H unit

Use this unit when the cylinder is operated in a load and speed range above the L unit limit line and below the H unit limit line.

⚠ Caution

1. Refer to the figure below when using the adjustment bolt to perform stroke adjustment.

When the effective stroke of the shock absorber decreases as a result of stroke adjustment, the absorption capacity decreases dramatically. Secure the adjustment bolt at the position where it protrudes approximately 0.5 mm from the shock absorber.

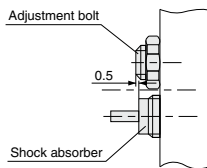

2. Do not use a shock absorber together with air cushion.

Absorption Capacity of Rubber Bumper, Air Cushion and Stroke Adjustment Units

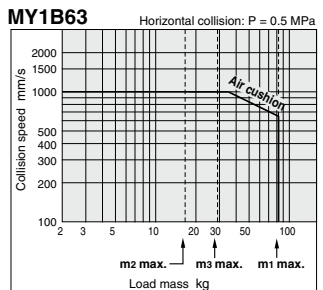
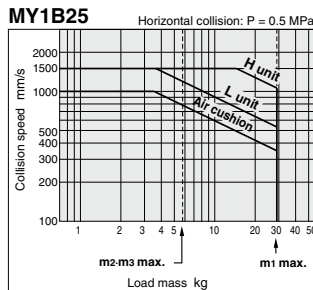
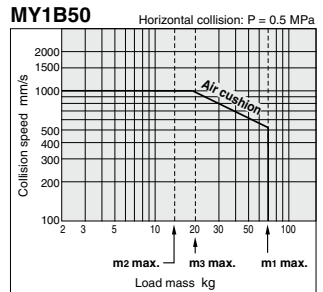
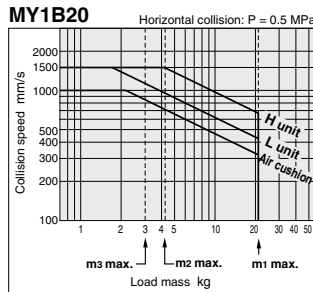
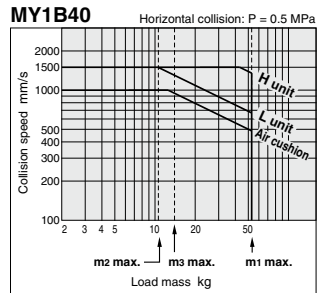
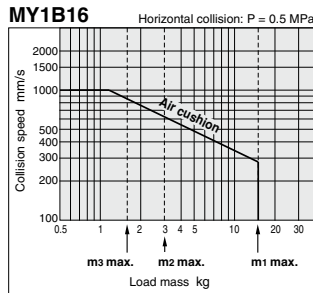
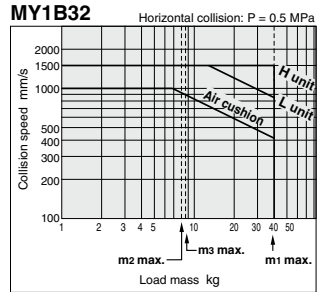
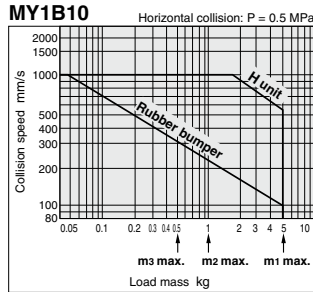

MY1B
-Z

MY1H
-Z

MY1B

MY1M

MY1C

MY1H

MY1
HT

MY1
□W

MY2C

MY2
□H

MY3A

MY3B

MY3M

D-□

-X□

Technical
data

Cushion Capacity

Rubber Bumper/Air Cushion Stroke Adjustment Unit Absorption Capacity

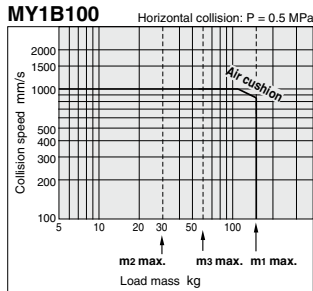
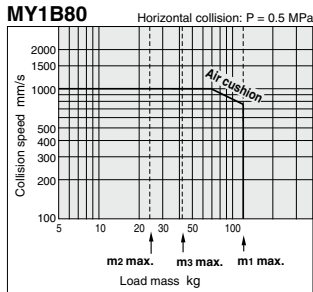

Air Cushion Stroke (mm)

Bore size (mm)	Cushion stroke
16	12
20	15
25	15
32	19
40	24
50	30
63	37
80	40
100	40

Rubber Bumper (ø10 only) Positive Stroke from One End Due to Pressure

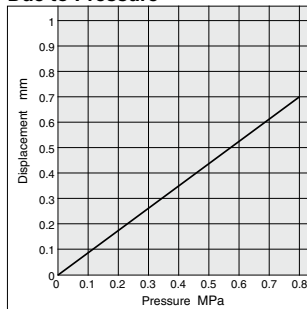

Tightening Torque for Stroke Adjustment Unit Holding Bolts (N·m)

Bore size (mm)	Unit	Tightening torque
10	A	0.4
	H	
16	A	0.7
	L	
20	A	1.8
	L	
	H	
25	A	3.5
	L	
	H	
32	A	5.8
	L	
	H	
40	A	13.8
	L	
	H	

Tightening Torque for Stroke Adjustment Unit Lock Plate Holding Bolts (N·m)

Bore size (mm)	Unit	Tightening torque
20	H	1.2
	L	1.2
25	H	3.3
	L	3.3
32	H	10
	L	3.3
40	L	3.3
	H	10

Calculation of Absorbed Energy for Stroke Adjustment Unit with Shock Absorber (N·m)

Type of impact	Horizontal collision	Vertical (Downward)	Vertical (Upward)
Kinetic energy E ₁	$\frac{1}{2} m \cdot v^2$		
Thrust energy E ₂	F · s	F _s + m · g · s	F _s - m · g · s
Absorbed energy E	E ₁ + E ₂		

Symbol

v: Speed of impact object (m/s)

F: Cylinder thrust (N)

s: Shock absorber stroke (m)

m: Mass of impact object (kg)

g: Gravitational acceleration (9.8 m/s²)

Note) The speed of the impact object is measured at the time of impact with the shock absorber.

⚠ Precautions

Be sure to read before handling. Refer to front matters 54 and 55 for Safety Instructions and pages 3 to 11 for Actuator and Auto Switch Precautions.

⚠ Caution

Use caution not to get your hands caught in the unit.

- When using a product with stroke adjustment unit, the space between the slide table (slider) and the stroke adjustment unit becomes narrow at the stroke end, causing a danger of hands getting caught. Install a protective cover to prevent direct contact with the human body.

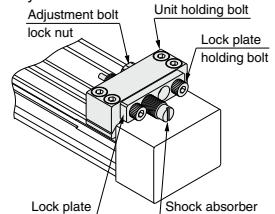

<Fastening of unit>

The unit can be secured by evenly tightening the four unit holding bolts.

⚠ Caution

Do not operate with the stroke adjustment unit fixed in an intermediate position.

When the stroke adjustment unit is fixed in an intermediate position, slippage can occur depending on the amount of energy released at the time of an impact. In such cases, as a stroke adjustment unit with the spacer for intermediate securing is available, it is recommended to use it.

(Except ø10)

For other lengths, please consult with SMC (Refer to "Tightening Torque for Stroke Adjustment Unit Holding Bolts".)

<Stroke adjustment with adjustment bolt>
Loosen the adjustment bolt lock nut, and adjust the stroke from the lock plate side using a hexagon wrench. Retighten the lock nut.

<Stroke adjustment with shock absorber>

Loosen the two lock plate holding bolts, turn the shock absorber and adjust the stroke. Then, uniformly tighten the lock plate holding bolts to secure the shock absorber.

Take care not to over-tighten the holding bolts. (Except ø10 and ø20 L unit.) (Refer to "Tightening Torque for Stroke Adjustment Unit Lock Plate Holding Bolts".)

Note)

Although the lock plate may slightly bend due to tightening of the lock plate holding bolt, this does not affect the shock absorber and locking function.

Construction: $\varnothing 10$

Centralized piping type: MY1B10G

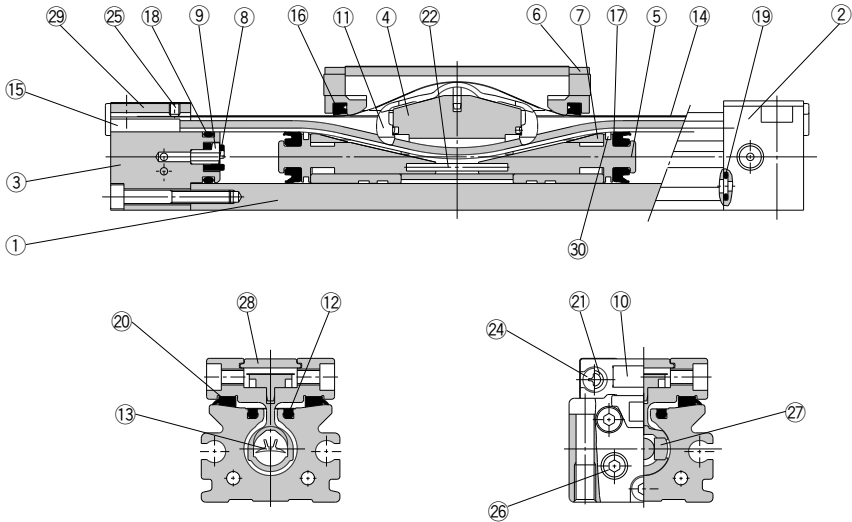

Component Parts

No.	Description	Material	Note
1	Cylinder tube	Aluminum alloy	Hard anodized
2	Head cover WR	Aluminum alloy	Painted
3	Head cover WL	Aluminum alloy	Painted
4	Piston yoke	Aluminum alloy	Hard anodized
5	Piston	Aluminum alloy	Chromated
6	End Cover	Special resin	
7	Wear ring	Special resin	
8	Bumper	Polyurethane rubber	
9	Holder	Stainless steel	
10	Stopper	Carbon steel	Nickel plated
11	Belt separator	Special resin	
12	Seal magnet	Rubber magnet	

No.	Description	Material	Note
15	Belt clamp	Special resin	
20	Bearing	Special resin	
21	Spacer	Chromium molybdenum steel	Nickel plated
22	Spring pin	Stainless steel	
23	Hexagon socket head cap screw	Chromium molybdenum steel	Nickel plated
24	Round binding head crew	Carbon steel	Nickel plated
25	Slotted set screw	Carbon steel	Black zinc chromated
26	Hexagon socket head plug	Carbon steel	Nickel plated
27	Magnet	—	
28	Top plate	Stainless steel	
29	Head plate	Stainless steel	
30	Felt	Felt	

Replacement Part: Seal Kit

No.	Description	Qty.	MY1B10
13	Seal belt	1	MY10-16A-Stroke
14	Dust seal band	1	MY10-16B-Stroke
16	Scraper	2	MY1B10-PS
17	Piston seal	2	
18	Tube gasket	2	
19	O-ring	4	

* Seal kit includes 15, 17, 18 and 19.

Seal kit includes a grease pack (10 g).

When 13 and 14 are shipped independently, a grease pack is included. (10 g per 1000 strokes)

Order with the following part number when only the grease pack is needed.

Grease pack part number: GR-S-010 (10 g), GR-S-020 (20 g)

MY1B
-Z

MY1H
-Z

MY1B

MY1M

MY1C

MY1H

MY1
HT

MY1
□W

MY2C

MY2
H□

MY3A
MY3B

MY3M

D-□

-X□

Technical
data

Series MY1B

Construction: $\varnothing 16$ to $\varnothing 100$

MY1B16 to 100

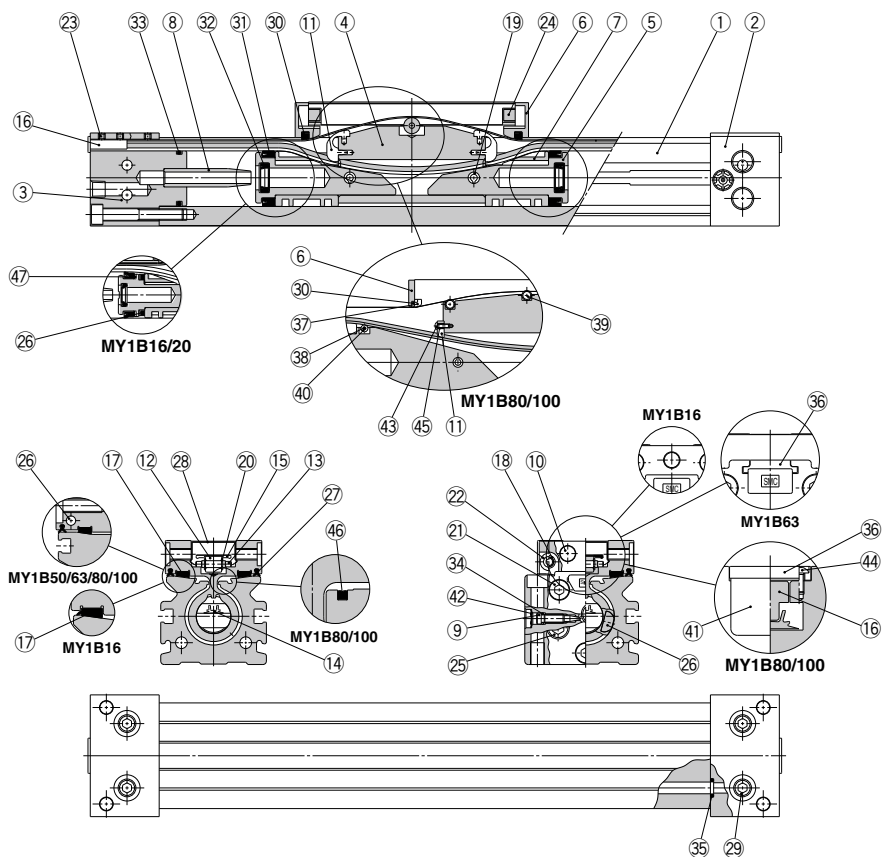

MY1B16 to 100

Component Parts

No.	Description	Material	Note
1	Cylinder tube	Aluminum alloy	Hard anodized
2	Head cover WR	Aluminum alloy	Painted
3	Head cover WL	Aluminum alloy	Painted
4	Piston yoke	Aluminum alloy	Anodized
5	Piston	Aluminum alloy	Chromated
6	End cover	Special resin	
		Carbon steel	Nickel plated (ø80, ø100)
7	Wear ring	Special resin	
8	Cushion ring	Aluminum alloy	Anodized
9	Cushion needle	Rolled steel	Nickel plated
10	Stopper	Carbon steel	Nickel plated
11	Belt separator	Special resin	
12	Guide roller	Special resin	(ø16 to ø63)
13	Guide roller shaft	Stainless steel	(ø16 to ø63)
16	Belt clamp	Special resin	
		Aluminum alloy	Chromated (ø80, ø100)
17	Bearing	Special resin	
18	Spacer	Stainless steel	(ø16 to ø63)
19	Spring pin	Carbon tool steel	
20	Type E retaining ring	Cold rolled special steel strip	(ø25 to ø63)
21	Hexagon socket head cap screw	Chromium molybdenum steel	Nickel plated
22	Hexagon socket button head screw	Chromium molybdenum steel	Nickel plated
23	Hexagon socket head set screw	Chromium molybdenum steel	Black zinc chromated/ Nickel plated
24	Double round parallel key	Carbon steel	(ø16 to ø40)
25	Hexagon socket head taper plug	Carbon steel	Nickel plated

No.	Description	Material	Note
26	Magnet	—	
28	Top cover	Stainless steel	
29	Hexagon socket head taper plug	Carbon steel	Nickel plated
36	Head plate	Aluminum alloy	Painted (ø63 to ø100)
37	Backup plate	Special resin	(ø80, ø100)
38	Guide roller B	Special resin	(ø80, ø100)
39	Guide roller A	Stainless steel	(ø80, ø100)
40	Guide roller shaft B	Stainless steel	(ø80, ø100)
41	Side cover	Aluminum alloy	Hard anodized (ø80, ø100)
42	Type CR retaining ring	Spring steel	
43	Hexagon socket button head screw	Chromium molybdenum steel	Nickel plated (ø80, ø100)
44	Hexagon socket button head screw	Chromium molybdenum steel	Nickel plated (ø80, ø100)
45	Spacer B	Stainless steel	(ø80, ø100)
46	Seal magnet	Rubber magnet	(ø80, ø100)
47	Leak retainer	Special resin	(ø16, ø20)

Replacement Part: Seal Kit

No.	Description	Qty.	MY1B16	MY1B20	MY1B25	MY1B32	MY1B40
14	Seal belt	1	MY16-16A-Stroke	MY20-16A-Stroke	MY25-16A-Stroke	MY32-16A-Stroke	MY40-16A-Stroke
15	Dust seal band	1	MY16-16B-Stroke	MY20-16B-Stroke	MY25-16B-Stroke	MY32-16B-Stroke	MY40-16B-Stroke
27	Side scraper	2	—	MYB20-15CA7164B	MYB25-15BA5900B	MYB32-15BA5901B	MYB40-15BA5902B
34	O-ring	2	KA00309 (ø4 x ø1.8 x ø1.1)	KA00309 (ø4 x ø1.8 x ø1.1)	KA00311 (ø5.1 x ø3 x ø1.05)	KA00320 (ø7.15 x ø3.75 x ø1.7)	KA00320 (ø7.15 x ø3.75 x ø1.7)
30	Scrape	2					
31	Piston seal	2					
32	Cushion seal	2	MY1B16-PS	MY1B20-PS	MY1B25-PS	MY1B32-PS	MY1B40-PS
33	Tube gasket	2					
35	O-ring	4					

No.	Description	Qty.	MY1B50	MY1B63	MY1B80	MY1B100
14	Seal belt	1	MY50-16A-Stroke	MY63-16A-Stroke	MY80-16A-Stroke	MY100-16A-Stroke
15	Dust seal band	1	MY50-16B-Stroke	MY63-16B-Stroke	MY80-16B-Stroke	MY100-16B-Stroke
27	Side scraper	2	MYB50-15CA7165B	MYB63-15CA7166B	MYB80-15CK2470B	MY100-15CK2471B
34	O-ring	2	KA00402 (ø8.3 x ø4.5 x ø1.9)	KA00777 —	KA00050 —	KA00050 —
30	Scrape	2				
31	Piston seal	2				
32	Cushion seal	2	MY1B50-PS	MY1B63-PS	MY1B80-PS	MY1B100-PS
33	Tube gasket	2				
35	O-ring	4				

* Seal kit includes ③, ④, ⑤, ⑥ and ⑦. Order the seal kit based on each bore size.

* Seal kit includes a grease pack (10 g).

When ⑭ and ⑮ are shipped independently, a grease pack is included. (10 g per 1000 strokes)

Order with the following part number when only the grease pack is needed.

Grease pack part number: GR-S-010 (10 g), GR-S-020 (20 g)

Note) Two kinds of dust seal bands are available for the MY1B16 to 63. Since the part number varies depending on the treatment of the hexagon socket head set screw ⑬, please check a proper dust seal band carefully.

A: Black zinc chromated—MY□□-16B-stroke, B: Nickel plated—MY□□-16BW-stroke

MY1B

-Z

MY1H

-Z

MY1B

MY1M

MY1C

MY1H

MY1 HT

MY1

□W

MY2C

MY2

H□

MY3A

MY3B

MY3M

MY3M

MY3M

MY3M

MY3M

MY3M

MY3M

MY3M

MY3M

MY3M

MY3M

MY3M

MY3M

MY3M

MY3M

MY3M

MY3M

MY3M

MY3M

MY3M

MY3M

MY3M

MY3M

MY3M

MY3M

MY3M

MY3M

MY3M

MY3M

MY3M

MY3M

MY3M

MY3M

MY3M

MY3M

MY3M

Series MY1B

Centralized Piping Type $\phi 10$

Refer to page 1325 regarding centralized piping port variations.

MY1B10G — Stroke

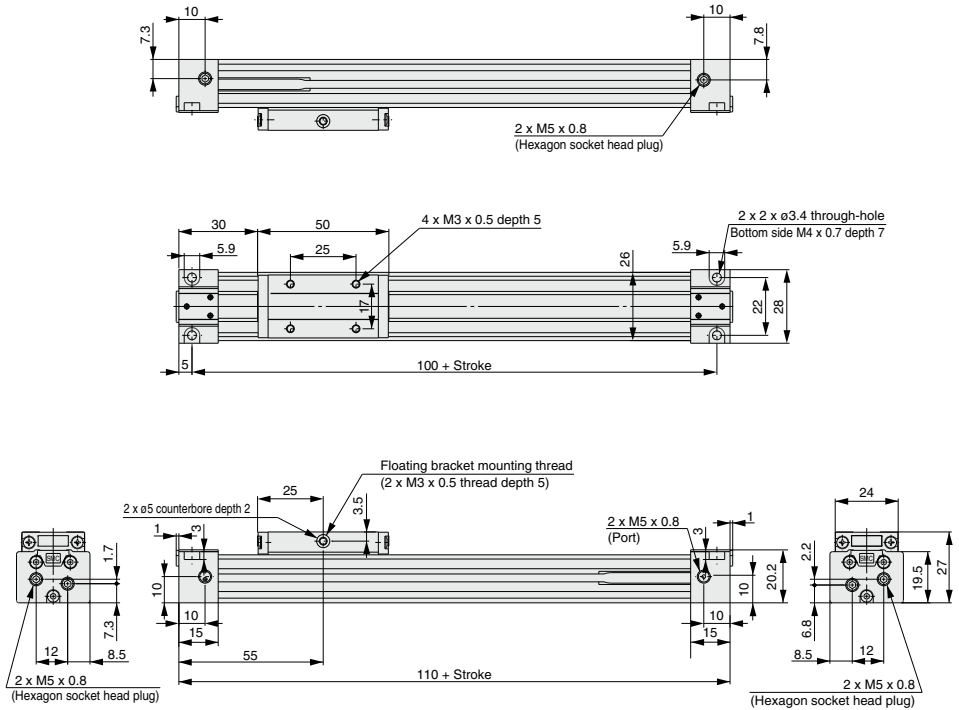

Mechanically Jointed Rodless Cylinder Basic Type **Series MY1B**

Standard Type/Centralized Piping Type $\phi 16, \phi 20$

Refer to page 1325 regarding centralized piping port variations.

MY1B16□/20□ — Stroke

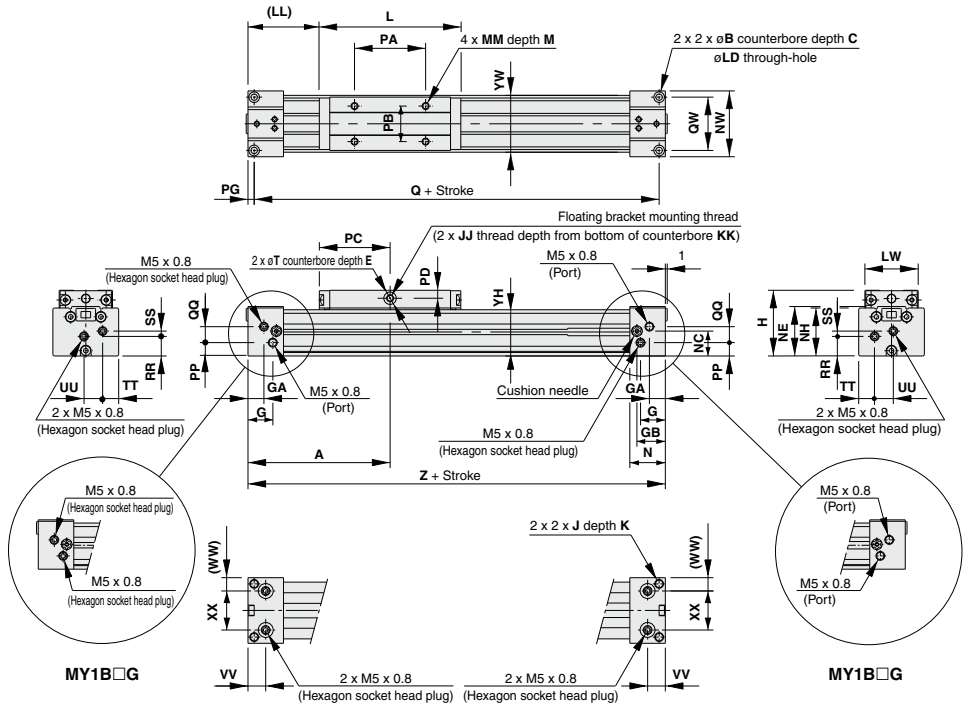

Model	A	B	C	E	G	GA	GB	H	J	JJ	K	KK	L	LD	LL	LW	M	MM	N	NC	NE
MY1B16□	80	6	3.5	2	14	9	16	37	M5 x 0.8	M4 x 0.7	10	6.5	80	3.5	40	30	6	M4 x 0.7	20	14	27.8
MY1B20□	100	7.5	4.5	2	12.5	12.5	20.5	46	M6 x 1	M4 x 0.7	12	10	100	4.5	50	37	8	M5 x 0.8	25	17.5	34

Model	NH	NW	PA	PB	PC	PD	PG	PP	Q	QQ	QW	RR	SS	T	TT	UU	VV	WW	XX	YH	YW	Z
MY1B16□	27	37	40	20	40	4.5	3.5	7.5	153	9	30	11	3	7	9	10.5	10	7.5	22	26	32	160
MY1B20□	33.5	45	50	25	50	5	4.5	11.5	191	11	36	14.5	5	8	10.5	12	12.5	10.5	24	32.5	40	200

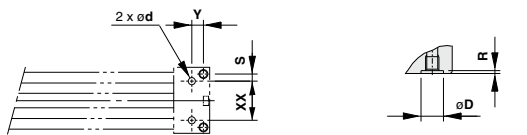

Bottom ported
(Applicable O-ring)

Hole Size for Centralized Piping on the Bottom							
Model	WX	Y	S	d	D	R	Applicable O-ring
MY1B16□	22	6.5	4	4	8.4	1.1	C6
MY1B20□	24	8	6	4	8.4	1.1	

(Machine the mounting side to the dimensions below.)

- MY1B-Z
- MY1H-Z
- MY1B
- MY1M
- MY1C
- MY1H
- MY1HT
- MY1W
- MY2C
- MY2H
- MY3A
- MY3B
- MY3M

Series MY1B

Standard Type/Centralized Piping Type $\phi 25, \phi 32, \phi 40$

Refer to page 1325 regarding centralized piping port variations.

MY1B25□/32□/40□ — Stroke

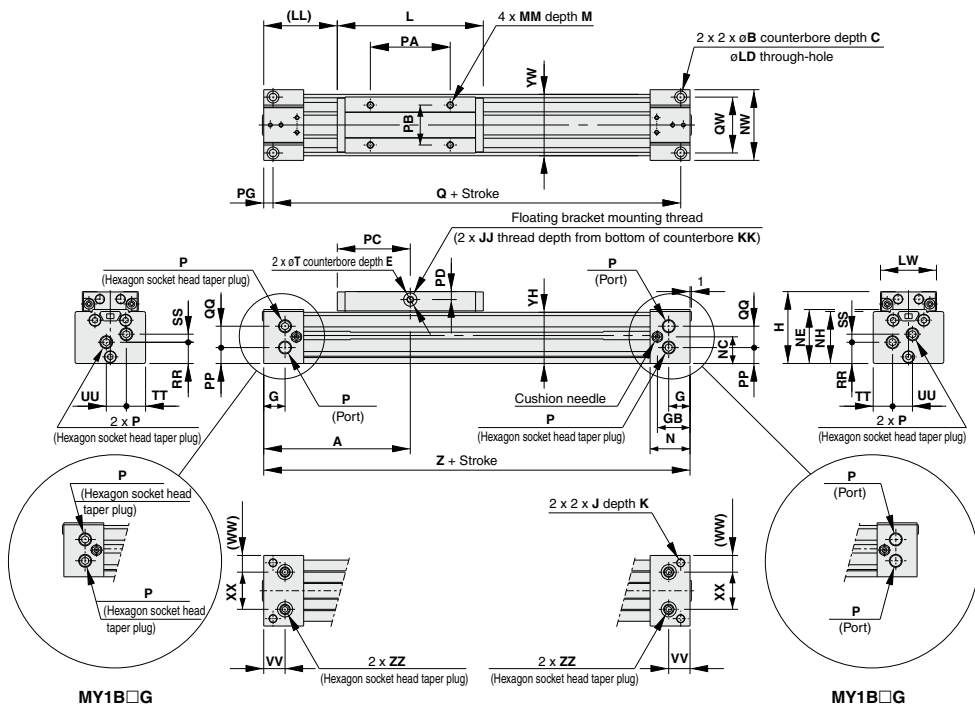

MY1B□G

MY1B□G

Model	A	B	C	E	G	GB	H	J	JJ	K	KK	L	LD	LL	LW	M	MM	N	NC	NE	NH	NW
MY1B25□	110	9	5.5	2	16	24.5	54	M6 x 1	M5 x 0.8	9.5	9	110	5.6	55	42	9	M5 x 0.8	30	20	40.5	39	53
MY1B32□	140	11	6.6	2	19	30	68	M8 x 1.25	M5 x 0.8	16	10	140	6.8	70	52	12	M6 x 1	37	25	50	49	64
MY1B40□	170	14	8.5	2	23	36.5	84	M10 x 1.5	M6 x 1	15	13	170	8.6	85	64	12	M6 x 1	45	30.5	63	61.5	75

(mm)

Model	P	PA	PB	PC	PD	PP	PG	Q	QQ	QW	RR	SS	T	TT	UU	VV	WW	XX	YH	YW	Z	ZZ
MY1B25□	Rc 1/8	60	30	55	6	12	7	206	16	42	16	6	10	14.5	15	16	12.5	28	38.5	46	220	Rc 1/16
MY1B32□	Rc 1/8	80	35	70	10	17	8	264	16	51	23	4	10	16	16	19	16	32	48	55	280	Rc 1/16
MY1B40□	Rc 1/4	100	40	85	12	18.5	9	322	24	59	27	10.5	14	20	22	23	19.5	36	60.5	67	340	Rc 1/8

(mm)

*P" indicates cylinder supply ports.

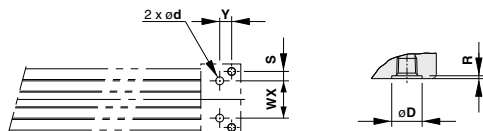

Bottom ported (ZZ)
(Applicable O-ring)

Hole Size for Centralized Piping on the Bottom

Model	WX	Y	S	d	D	R	Applicable O-ring
MY1B25□	28	9	7	6	11.4	1.1	C9
MY1B32□	32	11	9.5	6	11.4	1.1	
MY1B40□	36	14	11.5	8	13.4	1.1	

(Machine the mounting side to the dimensions below.)

Mechanically Jointed Rodless Cylinder Basic Type *Series MY1B*

Standard Type/Centralized Piping Type $\phi 50, \phi 63$

Refer to page 1325 regarding centralized piping port variations.

MY1B50□/63□ — Stroke

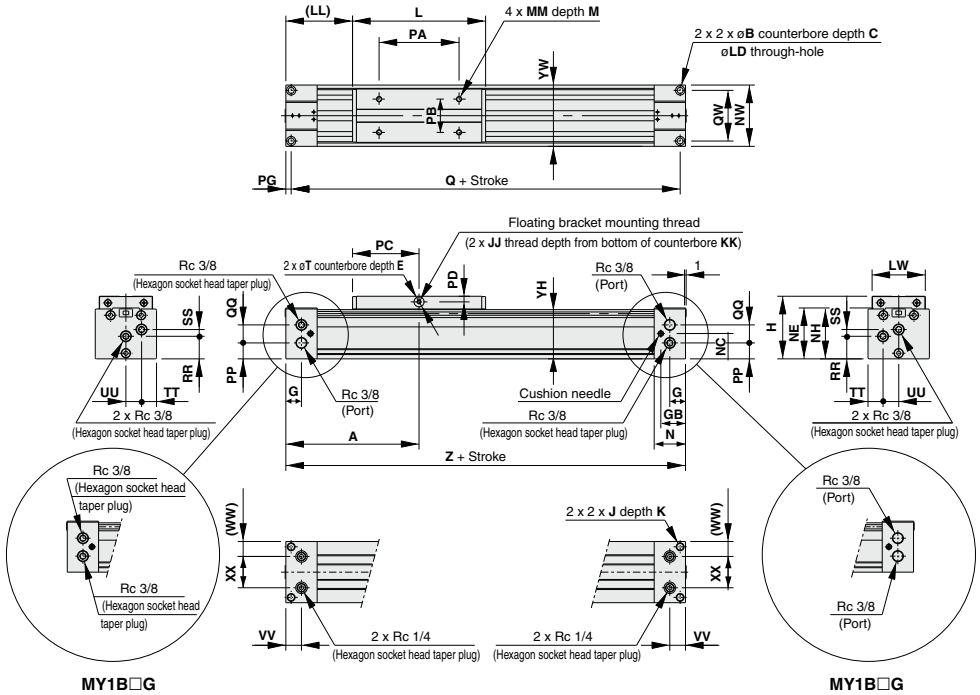

Model	A	B	C	E	G	GB	H	J	JJ	K	KK	L	LD	LL	LW	M	MM	N	NC	NE
MY1B50□	200	14	8.5	3	23.5	37	94	M12 x 1.75	M6 x 1	25	17	200	9	100	80	14	M8 x 1.25	47	38	76.5
MY1B63□	230	17	10.5	3	25	39	116	M14 x 2	M8 x 1.25	28	24	230	11	115	96	16	M8 x 1.25	50	51	100

Model	NH	NW	PA	PB	PC	PD	PG	PP	Q	QQ	QW	RR	SS	T	TT	UU	VV	WW	XX	YH	YW	Z
MY1B50□	75	92	120	50	100	8.5	8	24	384	27	76	34	10	15	22.5	23.5	23.5	22.5	47	74	92	400
MY1B63□	95	112	140	60	115	9.5	10	37.5	440	29.5	92	45.5	13.5	16	27	29	25	28	56	94	112	460

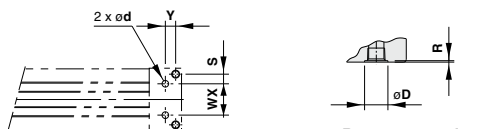

Hole Size for Centralized Piping on the Bottom

Model	WX	Y	S	d	D	R	Applicable O-ring
MY1B50□	47	15.5	14.5	10	17.5	1.1	C15
MY1B63□	56	15	18	10	17.5	1.1	

(Machine the mounting side to the dimensions below.)

- MY1B-Z
- MY1H-Z
- MY1B
- MY1M
- MY1C
- MY1H
- MY1HT
- MY1W
- MY2C
- MY2H
- MY3A
- MY3B
- MY3M

- D-□
- X□
- Technical data

Series MY1B

Standard Type/Centralized Piping Type $\phi 80, \phi 100$

Refer to page 1325 regarding centralized piping port variations.

MY1B80□/100□ — Stroke

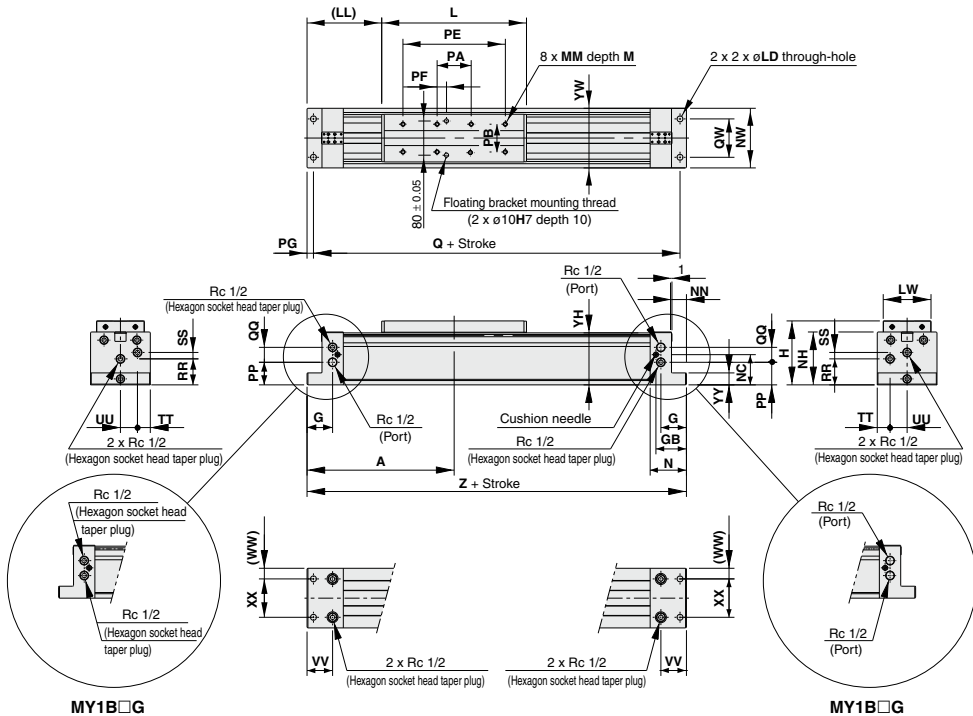

(mm)

Model	A	G	GB	H	L	LD	LL	LW	M	MM	N	NC	NH	NN	NW	PA	PB	PE
MY1B 80□	345	60	71.5	150	340	14	175	112	20	M10 x 1.5	85	71	124	35	140	80	65	240
MY1B100□	400	70	79.5	190	400	18	200	140	25	M12 x 1.75	95	85	157	45	176	120	85	280

(mm)

Model	PF	PG	PP	Q	QQ	QW	RR	SS	TT	UU	VV	WW	XX	YH	YW	YY	Z
MY1B 80□	22	15	53	660	35	90	61	15	30	40	60	25	90	122	140	28	690
MY1B100□	42	20	69	760	38	120	75	20	40	48	70	28	120	155	176	35	800

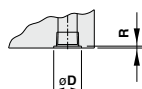
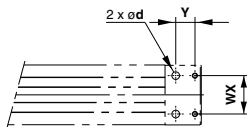

**Bottom ported
(Applicable O-ring)**

Hole Size for Centralized Piping on the Bottom

Model	WX	Y	d	D	R	Applicable O-ring
MY1B 80□	90	45	18	26	1.8	P22
MY1B100□	120	50	18	26	1.8	

(Machine the mounting side to the dimensions below.)

Stroke Adjustment Unit

With adjustment bolt

MY1B — A

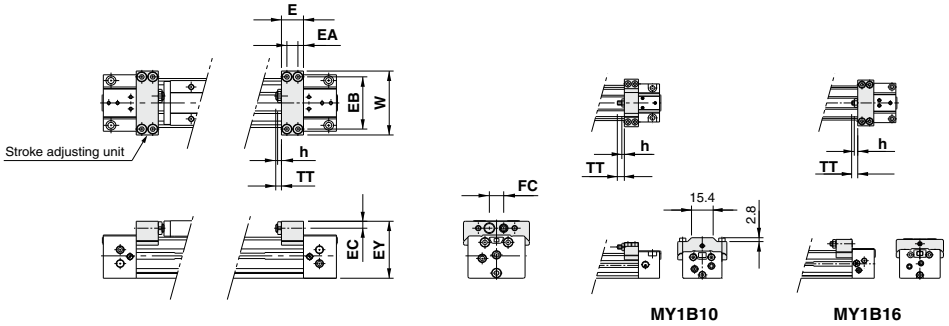

(mm)

Applicable bore size	E	EA	EB	EC	EY	FC	h	TT	W
MY1B10	10	5	28	3.3	26.3	—	1.8	5 (Max. 10)	35
MY1B16	14.6	7	34.4	4.2	36.5	—	2.4	5.4 (Max. 11)	43
MY1B20	19	9	43	5.8	45.6	13	3.2	6 (Max. 12)	53
MY1B25	20	10	49	6.5	53.5	13	3.5	5 (Max. 16.5)	60
MY1B32	25	12	61	8.5	67	17	4.5	8 (Max. 20)	74
MY1B40	31	15	76	9.5	81.5	17	4.5	9 (Max. 25)	94

With low load shock absorber + Adjustment bolt

MY1B — L

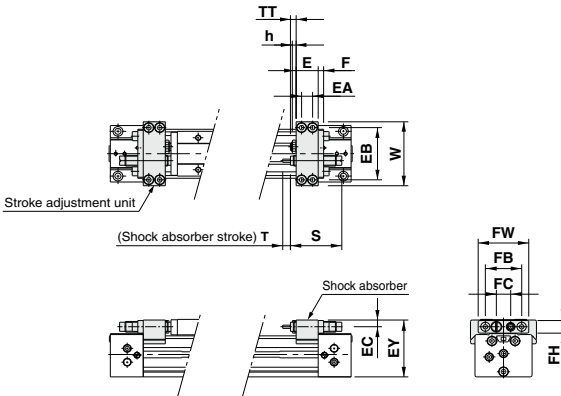

(mm)

Applicable bore size	E	EA	EB	EC	EY	F	FB	FC	FH	FW	h	S	T	TT	W	Shock absorber model
MY1B20	19	9	43	5.8	45.6	4	—	13	—	—	3.2	40.8	6	6 (Max. 12)	53	RB0806
MY1B25	20	10	49	6.5	53.5	6	33	13	12	46	3.5	46.7	7	5 (Max. 16.5)	60	RB1007
MY1B32	25	12	61	8.5	67	6	43	17	16	56	4.5	67.3	12	8 (Max. 20)	74	RB1412
MY1B40	31	15	76	9.5	81.5	6	43	17	16	56	4.5	67.3	12	9 (Max. 25)	94	RB1412

MY1B
-Z

MY1H
-Z

MY1B

MY1M

MY1C

MY1H

MY1
HT

MY1
□W

MY2C

MY2
H□

MY3A

MY3B

MY3M

D-□

-X□

Technical
data

Series MY1B

Stroke Adjustment Unit

With high load shock absorber + Adjustment bolt

MY1B Bore size — Stroke H

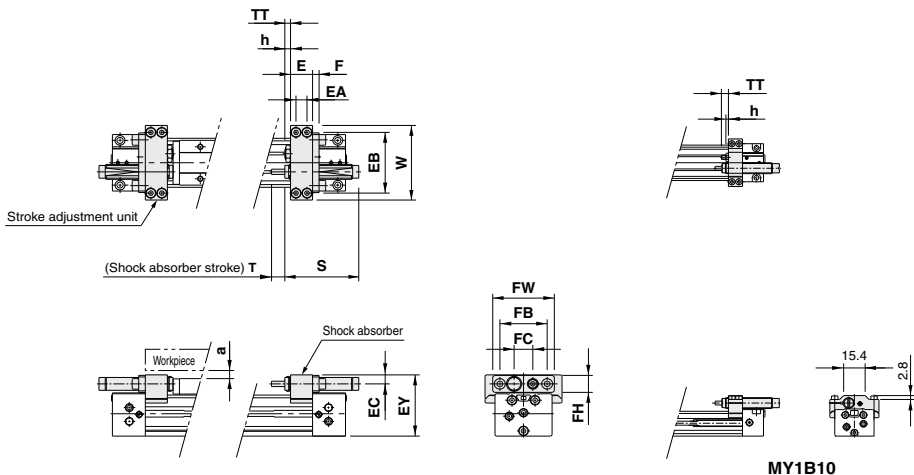

* Since the dimension EY of H unit is greater than the table top height (dimension H), when a workpiece is loaded that is larger than the full length (dimension L) of the slide table allow a clearance of size "a" or larger at the workpiece side. (mm)

Applicable bore size	E	EA	EB	EC	EY	F	FB	FC	FH	FW	h	S	T	TT	W	Shock absorber model	a
MY1B10	10	5	28	5.5	29.8	—	—	8	—	—	1.8	40.8	5	5 (Max. 10)	35	RB0805	3.5
MY1B20	20	10	49	6.5	47.5	6	33	13	12	46	3.5	46.7	7	5 (Max. 11)	60	RB1007	2.5
MY1B25	20	10	57	8.5	57.5	6	43	17	16	56	4.5	67.3	12	5 (Max. 16.5)	70	RB1412	4.5
MY1B32	25	12	74	11.5	73	8	57	22	22	74	5.5	73.2	15	8 (Max. 20)	90	RB2015	6
MY1B40	31	15	82	12	87	8	57	22	22	74	5.5	73.2	15	9 (Max. 25)	100	RB2015	4

Side Support

Side support A MY-S□A

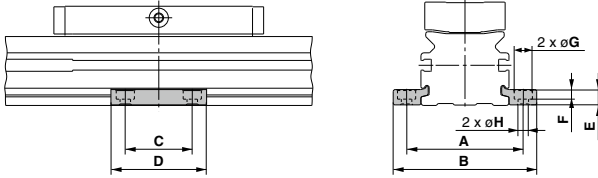

Side support B MY-S□B

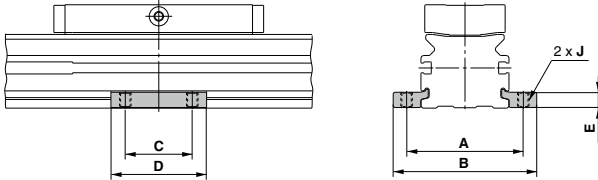

Model	Applicable bore size	A	B	C	D	E	F	G	H	J
MY-S10 ^A _B	MY1B 10	35	43.6	12	21	3	1.2	6.5	3.4	M4 x 0.7
MY-S16 ^A _B	MY1B 16	43	53.6	15	26	4.9	3	6.5	3.4	M4 x 0.7
MY-S20 ^A _B	MY1B 20	53	65.6	25	38	6.4	4	8	4.5	M5 x 0.8
MY-S25 ^A _B	MY1B 25	61	75	35	50	8	5	9.5	5.5	M6 x 1
	MY1B 32	70	84							
MY-S32 ^A _B	MY1B 40	87	105	45	64	11.7	6	11	6.6	M8 x 1.25
	MY1B 50	113	131							
MY-S50 ^A _B	MY1B 63	136	158	55	80	14.8	8.5	14	9	M10 x 1.5
	MY1B 80	170	200							
MY-S63 ^A _B	MY1B 80	170	200	70	100	18.3	10.5	17.5	11.5	M12 x 1.75
	MY1B100	206	236							

* A set of side supports consists of a left support and a right support.

Guide for Side Support Application

For long stroke operation, the cylinder tube may be deflected depending on its own weight and the load mass. In such a case, use a side support in the middle section. The spacing (L) of the support must be no more than the values shown in the graph on the right.

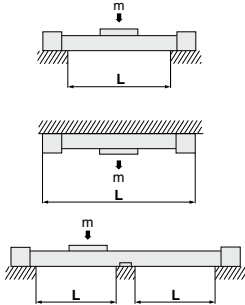

Caution

- If the cylinder mounting surfaces are not measured accurately, using a side support may cause poor operation. Therefore, be sure to level the cylinder tube when mounting. Also, for long stroke operation involving vibration and impact, use of a side support is recommended even if the spacing value is within the allowable limits shown in the graph.
- Support brackets are not for mounting; use them solely for providing support.

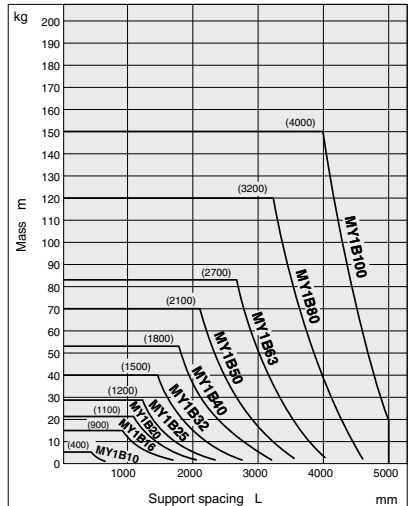

MY1B-Z

MY1H-Z

MY1B

MY1M

MY1C

MY1H

MY1HT

MY1□W

MY2C

MY2□H

MY3A

MY3B

MY3M

D-□

-X□

Technical data

Series MY1B

Floating Bracket

Facilitates connection to other guide systems.

Applicable bore size

ø10

MY-J10

Application Example

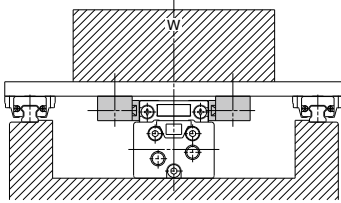

Mounting Example

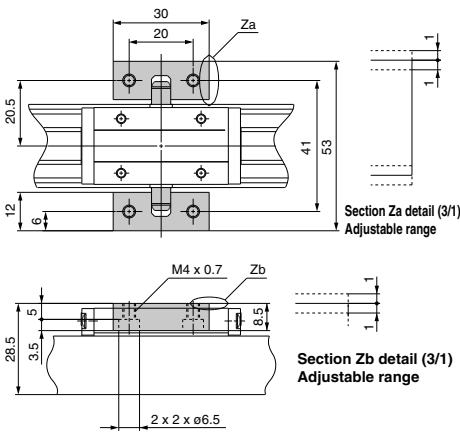

Note) A set of brackets with floating mechanism consists of a left bracket and a right bracket.

Applicable bore size

ø16, ø20

MY-J16/MY-J20

Application Example

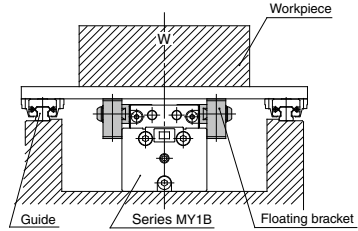

Mounting Example

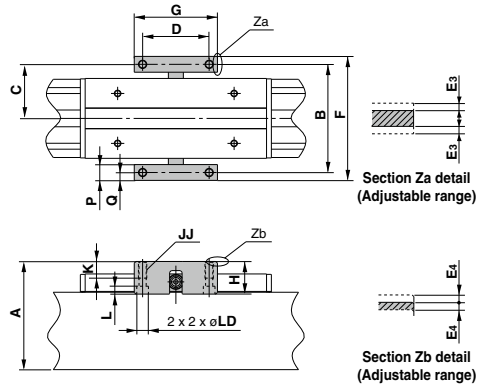

(mm)

Model	Applicable bore size	A	B	C	D	F	G	H
MY-J16	MY1B16□	45	45	22.5	30	52	38	18
MY-J20	MY1B20□	55	52	26	35	59	50	21

Model	Applicable bore size	JJ	K	L	P	Q	E3	E4	LD
MY-J16	MY1B16□	M4 x 0.7	10	4	7	3.5	1	1	6
MY-J20	MY1B20□	M4 x 0.7	10	4	7	3.5	1	1	6

Note) A set of brackets with floating mechanism consists of a left bracket and a right bracket.

Installation of Holding Bolts

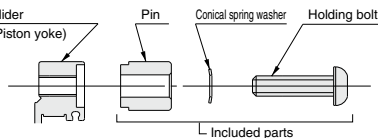

Included parts

Tightening Torque for Holding Bolts

(N·m)

Model	Tightening torque	Model	Tightening torque	Model	Tightening torque
MY-J10	0.6	MY-J25	3	MY-J50	5
MY-J16	1.5	MY-J32	5	MY-J63	13
MY-J20	1.5	MY-J40	5		

MY-J10 to 63 (1 set) Component Parts

Description	Qty.
Bracket	2
Pin	2
Conical spring washer	2
Holding bolt	2

Mechanically Jointed Rodless Cylinder Basic Type **Series MY1B**

Applicable bore size

ø25, ø32, ø40

MY-J25/MY-J32/MY-J40

Application Example

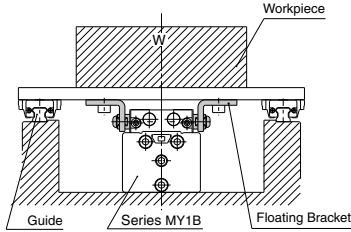

Mounting Example

One set of brackets can be mounted in two directions for compact combinations.

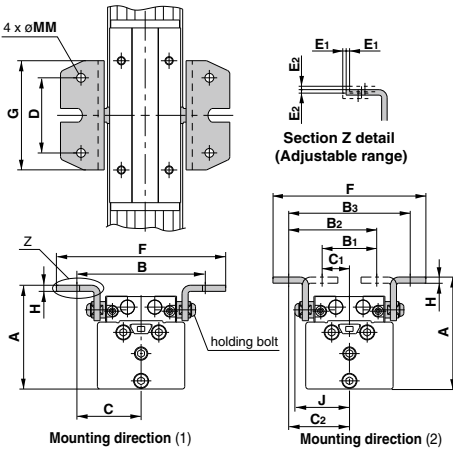

Model	Applicable bore size	Common					Mounting direction (1)				
		D	G	H	J	MM	A	B	C	F	
MY-J25	MY1B25□	40	60	3.2	35	5.5	63	78	39	100	
MY-J32	MY1B32□	55	80	4.5	40	6.5	76	94	124		
MY-J40	MY1B40□	74	100	4.5	47	6.5	92	112	144		

Model	Applicable bore size	Mounting direction (2)					Adjustable range			
		A	B1	B2	B3	C1	C2	F	E1	E2
MY-J25	MY1B25□	65	28	53	78	14	39	96	1	1
MY-J32	MY1B32□	82	40	64	88	20	44	111	1	1
MY-J40	MY1B40□	98	44	76	108	22	54	131	1	1

Note) A set of brackets with floating mechanism consists of a left bracket and a right bracket.

Applicable bore size

ø50, ø63

MY-J50/MY-J63

Application Example

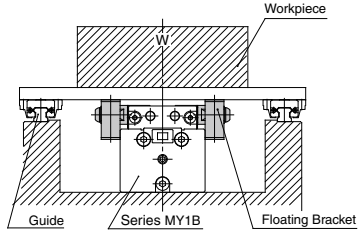

Mounting Example

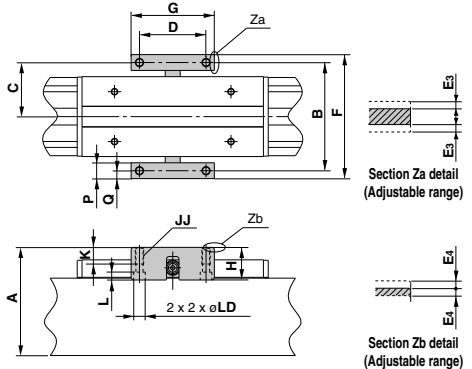

Model	Applicable bore size	A	B	C	D	F	G	H
MY-J50	MY1B50□	110	110	55	70	126	90	37
MY-J63	MY1B63□	131	130	65	80	149	100	37

Model	Applicable bore size	JJ	K	L	P	Q	E3	E4	LD
MY-J50	MY1B50□	M8 x 1.25	20	7.5	16	8	2.5	2.5	11
MY-J63	MY1B63□	M10 x 1.5	20	9.5	19	9.5	2.5	2.5	14

Note) A set of brackets with floating mechanism consists of a left bracket and a right bracket.

MY1B

-Z

MY1H

-Z

MY1B

MY1M

MY1C

MY1H

MY1HT

MY1□W

MY2C

MY2H□

MY3A

MY3B

MY3M

MY2H□

MY3A

MY3B

MY3M

MY2H□

MY3A

MY3B

MY3M

MY2H□

MY3A

MY3B

MY3M

MY2H□

MY3A

MY3B

MY3M

MY2H□

MY3A

MY3B

MY3M

MY2H□

MY3A

MY3B

MY3M

MY2H□

MY3A

MY3B

MY3M

Series MY1B

Floating Bracket

Facilitates connection to other guide systems.

Applicable bore size

Ø80, Ø100

MY-J80/MY-J100

Application Example

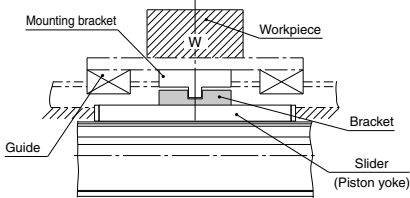

Mounting Example

Support bracket mounting area is heat treated at Hrc40 or above.

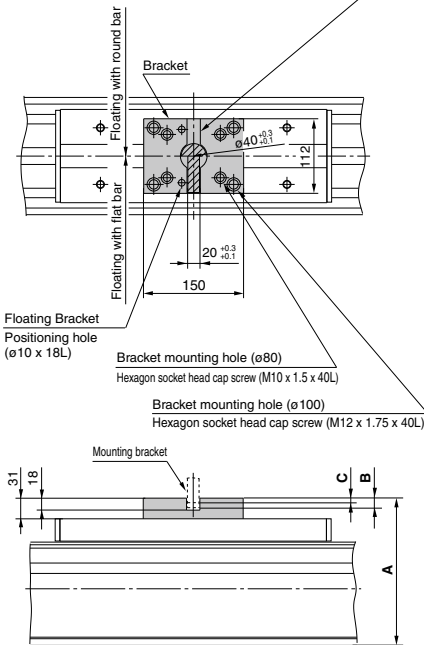

Hexagon Socket Head Cap Screw Tightening Torque (N·m)

Model	Applicable bore size	A	B (max.)	C (min.)	Model	Tightening torque
MY-J 80	MY1B 80□	181	15	9	MY-J 80	25
MY-J100	MY1B100□	221	15	9	MY-J100	44

Note) • Flat bar or round bar mounting are possible for the support bracket (slanted lines) mounted by the customer.

• "B" and "C" indicate the allowable mounting dimensions for the support bracket (flat bar or round bar).

• Consider support brackets with dimensions that allow the floating mechanism to function properly.

Floating Bracket Operating Precautions

⚠ Caution

When connecting to a load which has an external guide mechanism, use a discrepancy absorption mechanism.

Mount the external guide mounting brackets and floating brackets in a place where the required degree of freedom for the floating Y and Z axes can be secured.

The thrust transmission area of the floating bracket must be fixed so that it does not partially contact with the body.

* Confirm the Coordinates and Moments in Model Selection on page 1215 for the details of floating Y and Z axes.

MY-J80, 100 (1 set) Component Parts

Description	Qty.
Bracket	1
Parallel pin	2
Holding bolt	4

Series MY1M

Slide Bearing Guide Type

ø16, ø20, ø25, ø32, ø40, ø50, ø63

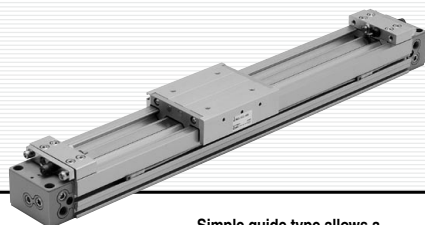

Simple guide type allows a workpiece to be mounted directly.

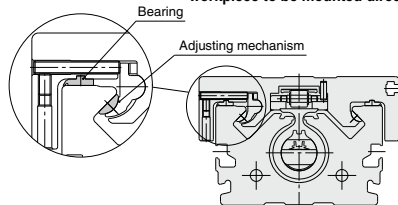

MY1B
-Z

MY1H
-Z

MY1B

MY1M

MY1C

MY1H

MY1
HT

MY1
□W

MY2C

MY2
H□

MY3A
MY3B

MY3M

D-□

-X□

Technical
data

Series MY1M Prior to Use

Maximum Allowable Moment/Maximum Load Mass

Model	Bore size (mm)	Maximum allowable moment (N·m)			Maximum load mass (kg)		
		M ₁	M ₂	M ₃	m ₁	m ₂	m ₃
MY1M	16	6.0	3.0	1.0	18	7	2.1
	20	10	5.2	1.7	26	10.4	3
	25	15	9.0	2.4	38	15	4.5
	32	30	15	5.0	57	23	6.6
	40	59	24	8.0	84	33	10
	50	115	38	15	120	48	14
	63	140	60	19	180	72	21

The above values are the maximum allowable values for moment and load. Refer to each graph regarding the maximum allowable moment and maximum allowable load for a particular piston speed.

Maximum Allowable Moment

Select the moment from within the range of operating limits shown in the graphs. Note that the maximum allowable load value may sometimes be exceeded even within the operating limits shown in the graphs. Therefore, also check the allowable load for the selected conditions.

Load mass (kg)

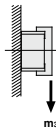
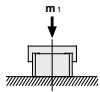

Moment (N·m)

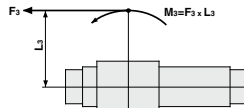
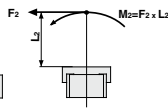
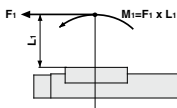

<Calculation of guide load factor>

1. Maximum allowable load (1), static moment (2), and dynamic moment (3) (at the time of impact with stopper) must be examined for the selection calculations.

* To evaluate, use \bar{v} a (average speed) for (1) and (2), and v (collision speed $v = 1.4\bar{v}$ a) for (3). Calculate m_{max} for (1) from the maximum allowable load graph (m_1, m_2, m_3) and M_{max} for (2) and (3) from the maximum allowable moment graph (M_1, M_2, M_3).

$$\text{Sum of guide load factors } \Sigma \alpha = \frac{\text{Load mass [m]}}{\text{Maximum allowable load [mmax]}} + \frac{\text{Static moment [M]}^{(1)}}{\text{Allowable static moment [Mmax]}} + \frac{\text{Dynamic moment [Me]}^{(2)}}{\text{Allowable dynamic moment [Mmax]}} \leq 1$$

Note 1) Moment caused by the load, etc., with cylinder in resting condition.

Note 2) Moment caused by the impact load equivalent at the stroke end (at the time of impact with stopper).

Note 3) Depending on the shape of the workpiece, multiple moments may occur. When this happens, the sum of the load factors (α) is the total of all such moments.

Maximum Load Mass

Select the load from within the range of limits shown in the graphs. Note that the maximum allowable moment value may sometimes be exceeded even within the operating limits shown in the graphs. Therefore, also check the allowable moment for the selected conditions.

2. Reference formula [Dynamic moment at impact]

Use the following formulae to calculate dynamic moment when taking stopper impact into consideration.

m: Load mass (kg)

F: Load (N)

F_E: Load equivalent to impact (at impact with stopper) (N)

\bar{v} a: Average speed (mm/s)

M: Static moment (N·m)

$$v = 1.4\bar{v}a \text{ (mm/s)} \quad F_E = 1.4\bar{v}a \cdot \delta \cdot m \cdot g$$

$$\therefore M_E = \frac{1}{3} \cdot F_E \cdot L_1 = 4.57\bar{v}a \delta m L_1 \text{ (N·m)}$$

v: Collision speed (mm/s)

L₁: Distance to the load's center of gravity (m)

M_E: Dynamic moment (N·m)

δ : Damper coefficient

With rubber bumper = 4/100

(MY1B10, MY1H10)

With air cushion = 1/100

With shock absorber = 1/100

g: Gravitational acceleration (9.8 mm/s²)

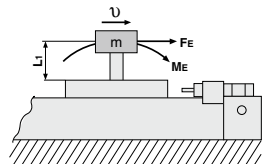

Note 4) $1.4\bar{v}a\delta$ is a dimensionless coefficient for calculating impact force.

Note 5) Average load coefficient ($= \frac{1}{3}$): This coefficient is for averaging the maximum load moment at the time of stopper impact according to service life calculations.

3. For detailed selection procedures, refer to pages 1246 and 1247.

MY1M/M₁

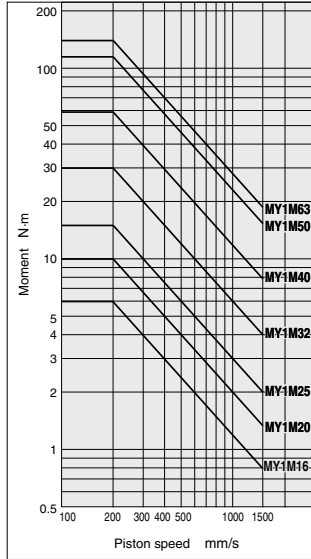

MY1M/M₂

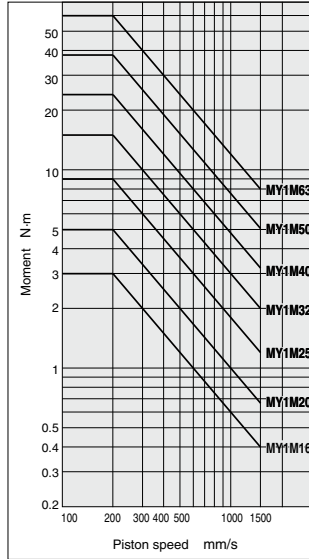

MY1M/M₃

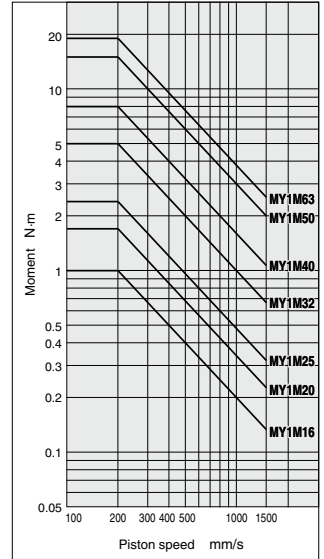

MY1M/m₁

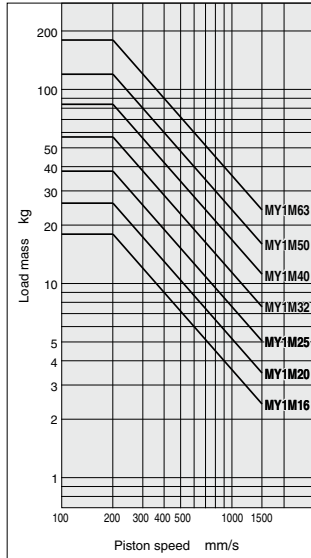

MY1M/m₂

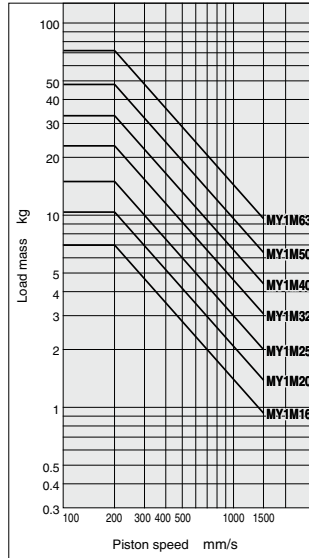

MY1M/m₃

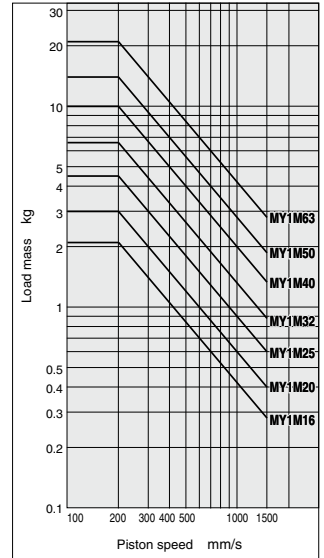

MY1B
-Z

MY1H
-Z

MY1B

MY1M

MY1C

MY1H

MY1
HT

MY1
□W

MY2C

MY2
H□

MY3A

MY3B

MY3M

D-□

-X□

Technical
data

Model Selection

Following are the steps for selecting the most suitable Series MY1M to your application.

Calculation of Guide Load Factor

1. Operating Conditions

Cylinder MY1M40-500

Average operating speed v_a ...200 mm/s

Mounting orientationHorizontal mounting

Cushion Air cushion
($\delta = 1/100$)

W_a: Connection plate $t = 10$ (880 g)

W_a: Workpiece (500 g)

W_c: MHL2-16D1 (795 g)

MY1M40-500

W_b: MGGLB25-200 (4.35 kg)

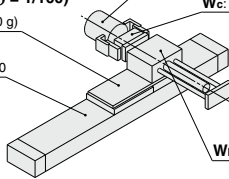

Mounting Orientation

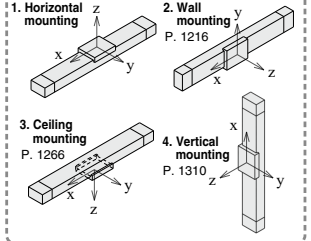

For actual examples of calculation for each orientation, refer to the pages above.

2. Load Blocking

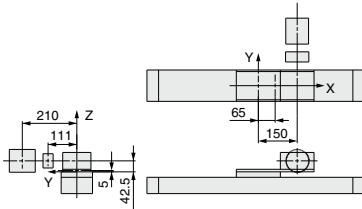

Mass and Center of Gravity for Each Workpiece

Workpiece no. W_n	Mass m_n	Center of gravity		
		X-axis X_n	Y-axis Y_n	Z-axis Z_n
W_a	0.88 kg	65 mm	0 mm	5 mm
W_b	4.35 kg	150 mm	0 mm	42.5 mm
W_c	0.795 kg	150 mm	111 mm	42.5 mm
W_d	0.5 kg	150 mm	210 mm	42.5 mm

$n=a, b, c, d$

3. Composite center of Gravity Calculation

$$m_1 = \sum m_n \\ = 0.88 + 4.35 + 0.795 + 0.5 = 6.525 \text{ kg}$$

$$X = \frac{1}{m_1} \times \sum (m_n \times x_n) \\ = \frac{1}{6.525} (0.88 \times 65 + 4.35 \times 150 + 0.795 \times 150 + 0.5 \times 150) = 138.5 \text{ mm}$$

$$Y = \frac{1}{m_1} \times \sum (m_n \times y_n) \\ = \frac{1}{6.525} (0.88 \times 0 + 4.35 \times 0 + 0.795 \times 111 + 0.5 \times 210) = 29.6 \text{ mm}$$

$$Z = \frac{1}{m_1} \times \sum (m_n \times z_n) \\ = \frac{1}{6.525} (0.88 \times 5 + 4.35 \times 42.5 + 0.795 \times 42.5 + 0.5 \times 42.5) = 37.4 \text{ mm}$$

4. Calculation of load factor for static load

m₁: Mass

m₁ max (from (1) of graph MY1M/m₁) = 84 (kg).....

Load factor $\alpha_1 = m_1/m_1 \text{ max} = 6.525/84 = 0.08$

M₁: Moment

M₁ max (from (2) of graph MY1M/M₁) = 59 (N·m).....

M₁ = **m₁** × **g** × **X** = 6.525 × 9.8 × 138.5 × 10⁻³ = 8.86 (N·m)

Load factor $\alpha_2 = M_1/M_1 \text{ max} = 8.86/59 = 0.15$

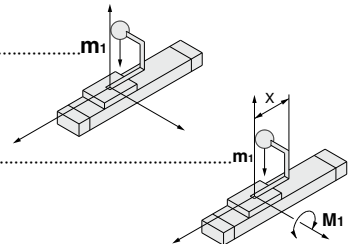

M_2 : Moment

$M_2 \text{ max}$ (from (3) of graph MY1M/ M_2) = 24 (N·m).....

$M_3 = m_1 \times g \times Y = 6.525 \times 9.8 \times 29.6 \times 10^{-3} = 1.89$ (N·m)

Load factor $\alpha_3 = M_2/M_2 \text{ max} = 1.89/24 = 0.08$

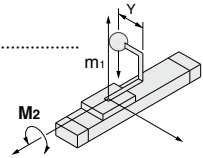

5. Calculation of Load Factor for Dynamic Moment

Equivalent load F_E at impact

$$F_E = 1.40a \times \delta \times m \times g = 1.4 \times 200 \times \frac{1}{100} \times 6.525 \times 9.8 = 179.1 \text{ (N)}$$

M_{1E} : Moment

$M_{1E} \text{ max}$ (from (4) of graph MY1M/ M_1 where $1.40a = 280$ mm/s) = 42.1 (N·m).....

$$M_{1E} = \frac{1}{3} \times F_E \times Z = \frac{1}{3} \times 179.1 \times 37.4 \times 10^{-3} = 2.23 \text{ (N·m)}$$

Load factor $\alpha_4 = M_{1E}/M_{1E} \text{ max} = 2.23/42.1 = 0.05$

M_{3E} : Moment

$M_{3E} \text{ max}$ (from (5) of graph MY1M/ M_3 where $1.40a = 280$ mm/s) = 5.7 (N·m).....

$$M_{3E} = \frac{1}{3} \times F_E \times Y = \frac{1}{3} \times 179.1 \times 29.6 \times 10^{-3} = 1.77 \text{ (N·m)}$$

Load factor $\alpha_5 = M_{3E}/M_{3E} \text{ max} = 1.77/5.7 = 0.31$

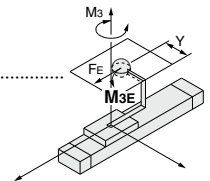
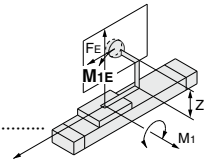

6. Sum and Examination of Guide Load Factors

$$\Sigma \alpha = \alpha_1 + \alpha_2 + \alpha_3 + \alpha_4 + \alpha_5 = 0.67 \leq 1$$

The above calculation is within the allowable value, and therefore the selected model can be used.

Select a shock absorber separately.

In an actual calculation, when the total sum of guide load factors α in the formula above is more than 1, consider either decreasing the speed, increasing the bore size, or changing the product series. This calculation can be easily made using the "SMC Pneumatics CAD System".

MY1B

-Z

MY1H

-Z

MY1B

MY1M

MY1C

MY1H

MY1

HT

MY1

□W

MY2C

MY2

□H

MY3A

MY3B

MY3M

Load Mass

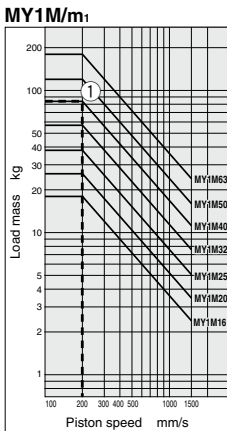

Allowable Moment

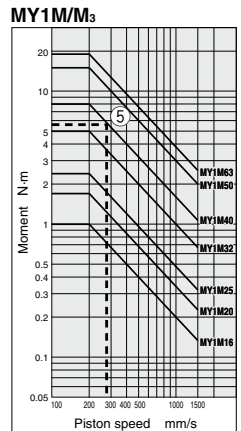
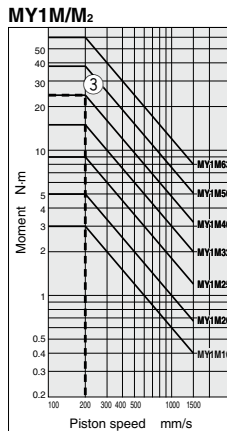
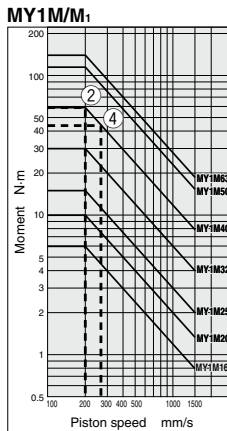

D-□

-X□

Technical data

Mechanically Jointed Rodless Cylinder Slide Bearing Guide Type

Series MY1M

ø16, ø20, ø25, ø32, ø40, ø50, ø63

How to Order

Slide bearing guide type **MY1M 20** **G** - **300 L** - **M9BW** -

Slide bearing guide type

Bore size

16	16 mm
20	20 mm
25	25 mm
32	32 mm
40	40 mm
50	50 mm
63	63 mm

Port thread type

Symbol	Type	Bore size
Nil	M thread	ø16, ø20
	Rc	ø25, ø32,
TN	NPT	ø40, ø50,
TF	G	ø63

Piping

Nil	Standard type
G	Centralized piping type

Cylinder stroke (mm)

Bore size (mm)	Standard stroke (mm)*	Maximum manufacturable stroke (mm)
16	100, 200, 300, 400, 500, 600, 700	3000
20, 25, 32, 40, 50, 63	800, 900, 1000, 1200, 1400, 1600, 1800, 2000	5000

* The stroke can be manufactured up to the maximum stroke from 1 mm stroke in 1 mm increments. However, when the stroke is 49 mm or less, the air cushion capability lowers and multiple auto switches cannot be mounted. Pay special attention to this point. Also when exceeding a 2000 mm stroke, specify "-XB11" at the end of the model number. For details, refer to the "Made to Order Specifications"

Made to Order
Refer to page 1249 for details.

Number of auto switches

Nil	2 pcs.
S	1 pc.
n	"n" pcs.

Auto switch

Nil	Without auto switch (Built-in magnet)
-----	---------------------------------------

Applicable auto switches vary depending on the bore size. Select an applicable one referring to the table below.

Stroke adjustment unit symbol
Refer to "Stroke adjustment unit" on page 1249.

Applicable Auto Switches

Type	Special function	Electrical entry	Indicator light	Wiring (Output)	Load voltage		Auto switch model		Lead wire length (m)				Pre-wired connector	Applicable load			
					DC	AC	Perpendicular	In-line	0.5 (Nil)	1 (M)	3 (L)	5 (Z)					
															ø16, ø20	ø25 to ø63	ø16, ø20
Solid state auto switch	—	Grommet	Yes	3-wire (NPN)	24 V	5 V, 12 V	—	M9NV	M9N	●	●	○	○	IC circuit	Relay, PLC		
				3-wire (PNP)				M9PV	M9P	●	●	○	○				
				2-wire				M9BV	M9B	●	●	○	○				
				3-wire (NPN)				M9NWW	M9NW	●	●	○	○				
	Diagnostic indication (2-color indication)			3-wire (PNP)	M9PVV	M9PW	●	●	○	○	IC circuit						
				2-wire	M9BWW	M9BW	●	●	○	○							
				3-wire (PNP)	M9NAV**	M9NA**	○	○	○	○		IC circuit					
				3-wire (PNP)	M9PAV**	M9PA**	○	○	○	○							
Water resistant (2-color indication)	2-wire	M9BAV**	M9BA**	○	○	○	○	IC circuit									
	3-wire (NPN equivalent)	—	5 V	—	A96V	—	A96		Z76	●	●	—	—	IC circuit	—		
	No	2-wire	24 V	12 V	100 V	A93V	—		A93	Z73	●	●	●			—	Relay, PLC
					100 V or less	A90V	—		A90	Z70	●	●	—			—	

** Water resistant type auto switches can be mounted on the above models, but in such case SMC cannot guarantee water resistance. Consult with SMC regarding water resistant types with the above model numbers.

* Lead wire length symbols: 0.5 m Nil (Example) M9NW
1 m M (Example) M9NWW
3 m L (Example) M9NWL
5 m Z (Example) M9NWL

* Solid state auto switches marked with "○" are produced upon receipt of order.
* Separate switch spacers (BMG2-012) are required to retrofit auto switches (M9 type) on cylinders ø25 to ø63.

* There are other applicable auto switches than listed above. For details, refer to page 1321.

* For details about auto switches with pre-wired connector, refer to pages 1626 and 1627.

* Auto switches are shipped together (not assembled). (Refer to pages 1319 to 1321 for the details of auto switch mounting.)

Mechanically Jointed Rodless Cylinder Slide Bearing Guide Type **Series MY1M**

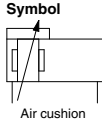
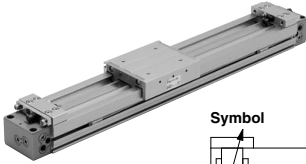

Made to Order

Made to Order: Individual Specifications
(For details, refer to page 1322.)

Symbol	Specifications
-X168	Helical insert thread specifications

Made to Order Specifications
(For details, refer to pages 1699 to 1818.)

Symbol	Specifications
-XB11	Long stroke
-XB22	Shock absorber soft type Series RJ type
-XC67	NBR rubber lining in dust seal band

Specifications

Bore size (mm)	16	20	25	32	40	50	63
Fluid	Air						
Action	Double acting						
Operating pressure range	0.15 to 0.8 MPa						
Proof pressure	1.2 MPa						
Ambient and fluid temperature	5 to 60°C						
Cushion	Air cushion						
Lubrication	Non-lube						
Stroke length tolerance	1000 or less $^{+1.8}_0$ 1001 to 3000 $^{+2.8}_0$		2700 or less $^{+1.8}_0$, 2701 to 5000 $^{+2.8}_0$				
Piping port size	Front/Side port M5 x 0.8		Bottom port ø4		Rc 1/8	Rc 1/4	Rc 3/8

Piston Speed

Bore size (mm)		16 to 63
Without stroke adjustment unit		100 to 1000 mm/s
Stroke adjustment unit		100 to 1000 mm/s ⁽¹⁾
L unit and H unit		100 to 1500 mm/s ⁽²⁾

Note 1) Be aware that when the stroke adjustment range is increased by manipulating the adjustment bolt, the air cushion capacity decreases. Also, when exceeding the air cushion stroke ranges on page 1252, the piston speed should be 100 to 200 mm per second.

Note 2) The piston speed is 100 to 1000 mm/s for centralized piping.

Note 3) Use at a speed within the absorption capacity range. Refer to page 1252.

Stroke Adjustment Unit Specifications

Bore size (mm)		16		20		25		32		40		50		63	
Unit symbol		A	L	A	L	H	A	L	H	A	L	H	A	L	H
Configuration Shock absorber model	Without spacer	RB 0806 + with adjustment bolt		RB 0806 + with adjustment bolt		RB 1007 + with adjustment bolt		RB 1412 + with adjustment bolt		RB 2015 + with adjustment bolt		RB 2725 + with adjustment bolt		RB 2725 + with adjustment bolt	
	With short spacer	0 to -5.6		0 to -6		0 to -11.5		0 to -12		0 to -16		0 to -20		0 to -25	
	With long spacer	-5.6 to -11.2		-6 to -12		-11.5 to -23		-12 to -24		-16 to -32		-20 to -40		-25 to -50	
Stroke adjustment range by intermediate fixing spacer (mm)		-11.2 to -16.8		-12 to -18		-23 to -34.5		-24 to -36		-32 to -48		-40 to -60		-50 to -75	

* Stroke adjustment range is applicable for one side when mounted on a cylinder.

Stroke Adjustment Unit Symbol

		Right side stroke adjustment unit														
		Without unit	A: With adjustment bolt				L: With low load shock absorber + Adjustment bolt				H: With high load shock absorber + Adjustment bolt					
			With short spacer	With long spacer	With short spacer	With long spacer	With short spacer	With long spacer	With short spacer	With long spacer	With short spacer	With long spacer	With short spacer	With long spacer	With short spacer	With long spacer
Left side stroke adjustment unit	Without unit	Nil	SA	SA6	SA7	SL	SL6	SL7	SH	SH6	SH7					
	A: With adjustment bolt	AS	A	AA6	AA7	AL	AL6	AL7	AH	AH6	AH7					
	With short spacer	A6S	A6A	A6	A6A7	A6L	A6L6	A6L7	A6H	A6H6	A6H7					
	With long spacer	A7S	A7A	A7A6	A7	A7L	A7L6	A7L7	A7H	A7H6	A7H7					
	L: With low load shock absorber + Adjustment bolt	LS	LA	LA6	LA7	L	LL6	LL7	LH	LH6	LH7					
	With short spacer	L6S	L6A	L6A6	L6A7	L6L	L6L6	L6L7	L6H	L6H6	L6H7					
	With long spacer	L7S	L7A	L7A6	L7A7	L7L	L7L6	L7L7	L7H	L7H6	L7H7					
	H: With high load shock absorber + Adjustment bolt	HS	HA	HA6	HA7	HL	HL6	HL7	H	HH6	HH7					
	With short spacer	H6S	H6A	H6A6	H6A7	H6L	H6L6	H6L7	H6H	H6H6	H6H7					
	With long spacer	H7S	H7A	H7A6	H7A7	H7L	H7L6	H7L7	H7H	H7H6	H7H7					

* Spacers are used to fix the stroke adjustment unit at an intermediate stroke position.

Stroke adjustment unit mounting diagram

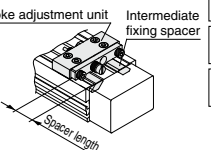

Example of L6L7 attachment

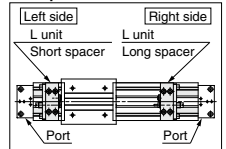

Shock Absorbers for L and H Units

Type	Stroke adjustment unit	Bore size (mm)					
		16	20	25	32	40	50
Standard (Shock absorber/RB series)	L	RB0806	RB1007	RB1412	RB2015	RB2725	
	H	—	RB1007	RB1412	RB2015	RB2725	
Shock absorber/soft type RJ series mounted (-XB22)	L	RJ0806H	RJ1007H	RJ1412H	—	—	
	H	—	RJ1007H	RJ1412H	—	—	

* The shock absorber service life is different from that of the MY1M cylinder depending on operating conditions. Refer to the RB Series Specific Product Precautions for the replacement period.

* Mounted shock absorber soft type RJ series (-XB22) is made to order specifications. For details, refer to page 1722.

Shock Absorber Specifications

Model	RB 0806	RB 1007	RB 1412	RB 2015	RB 2725	
Max. energy absorption (J)	2.9	5.9	19.6	58.8	147	
Stroke absorption (mm)	6	7	12	15	25	
Max. collision speed (mm/s)	1500					
Max. operating frequency (cycle/min)	80	70	45	25	10	
Spring force (N)	Extended	1.96	4.22	6.86	8.34	8.83
	Retracted	4.22	6.86	15.98	20.50	20.01
Operating temperature range (°C)	5 to 60					

* The shock absorber service life is different from that of the MY1M cylinder depending on operating conditions. Refer to the RB Series Specific Product Precautions for the replacement period.

Series MY1M

Theoretical Output

Bore size (mm)	Piston area (mm ²)	Operating pressure (MPa)						
		0.2	0.3	0.4	0.5	0.6	0.7	0.8
16	200	40	60	80	100	120	140	160
20	314	62	94	125	157	188	219	251
25	490	98	147	196	245	294	343	392
32	804	161	241	322	402	483	563	643
40	1256	251	377	502	628	754	879	1005
50	1962	392	588	784	981	1177	1373	1569
63	3115	623	934	1246	1557	1869	2180	2492

Note) Theoretical output (N) = Pressure (MPa) x Piston area (mm²)

Weight

Bore size (mm)	Basic weight	Additional weight per each 50 mm of stroke	Weight of moving parts	Side support bracket weight (per set)	Stroke adjustment unit weight (per unit)		
				Type A and B	A unit weight	L unit weight	H unit weight
16	0.67	0.12	0.19	0.01	0.03	0.04	—
20	1.11	0.16	0.28	0.02	0.04	0.05	0.08
25	1.64	0.24	0.39	0.02	0.07	0.11	0.18
32	3.27	0.38	0.81	0.04	0.14	0.23	0.39
40	5.88	0.56	1.41	0.08	0.25	0.34	0.48
50	10.06	0.77	2.51	0.08	0.36	0.51	0.81
63	16.57	1.11	3.99	0.17	0.68	0.83	1.08

Calculation: (Example) MY1M25-300A

- Basic weight 1.64 kg
- Cylinder stroke 300 stroke
- Additional weight 0.24/50 stroke
- $1.64 + 0.24 \times 300/50 + 0.07 \times 2 \approx 3.22$ kg
- Weight of A unit 0.07 kg

Option

Stroke Adjustment Unit Part No.

MYM-A 25 L2-6N

Stroke adjustment unit

Intermediate fixing spacer

Spacer delivery style

Spacer length

Bore size	16 mm	20 mm	25 mm	32 mm	40 mm	50 mm	63 mm
16	16 mm						
20		20 mm					
25			25 mm				
32				32 mm			
40					40 mm		
50						50 mm	
63							63 mm

Symbol	Stroke adjustment unit	Mounting position
A1	A unit	Left
A2		Right
L1	L unit	Left
L2		Right
H1	H unit	Left
H2		Right

Unit no.	Without spacer	Short spacer	Long spacer
6	<input type="checkbox"/>	<input checked="" type="checkbox"/>	<input type="checkbox"/>
7	<input type="checkbox"/>	<input type="checkbox"/>	<input checked="" type="checkbox"/>

Spacer delivery style	Unit installed
NII	<input type="checkbox"/>
N	<input checked="" type="checkbox"/>

* Spacers are used to fix the stroke adjustment unit at an intermediate stroke position.
* Spacers are shipped for a set of two.

Component Parts

MYM-A25L2 (Without spacer)	MYM-A25L2-6 (With short spacer)	MYM-A25L2-7 (With long spacer)	MYM-A25L2-6N (Short spacer only)
			MYM-A25L2-7N (Long spacer only)

Side Support Part No.

Bore size (mm)	16	20	25	32	40	50	63
Side support A	MY-S16A	MY-S20A	MY-S25A	MY-S32A	MY-S40A		MY-S63A
Side support B	MY-S16B	MY-S20B	MY-S25B	MY-S32B	MY-S40B		MY-S63B

For details about dimensions, etc., refer to page 1261.

A set of side supports consists of a left support and a right support.

Cushion Capacity

Cushion Selection

<Air cushion>

Air cushions are a standard feature on mechanically jointed rodless cylinders. The air cushion mechanism is incorporated to prevent excessive impact of the piston at the stroke end during high speed operation. The purpose of air cushion, thus, is not to decelerate the piston near the stroke end. The ranges of load and speed that air cushions can absorb are within the air cushion limit lines shown in the graphs.

<Stroke adjustment unit with shock absorber>

Use this unit when operating with a load or speed exceeding the air cushion limit line, or when cushioning is required outside of the effective air cushion stroke range due to stroke adjustment.

<L unit>

Use this unit when the cylinder stroke is outside of the effective air cushion range even if the load and speed are within the air cushion limit line, or when the cylinder is operated in a load and speed range above the air cushion limit line or below the L unit limit line.

<H unit>

Use this unit when the cylinder is operated in a load and speed range above the L unit limit line and below the H unit limit line.

⚠ Caution

1. Refer to the figure below when using the adjustment bolt to perform stroke adjustment.

When the effective stroke of the shock absorber decreases as a result of stroke adjustment, the absorption capacity decreases dramatically. Secure the adjustment bolt at the position where it protrudes approximately 0.5 mm from the shock absorber.

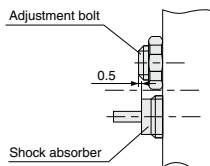

2. Do not use a shock absorber together with air cushion.

Air Cushion Stroke (mm)

Bore size (mm)	Cushion stroke
16	12
20	15
25	15
32	19
40	24
50	30
63	37

Absorption Capacity of Air Cushion and Stroke Adjustment Units

MY1M16

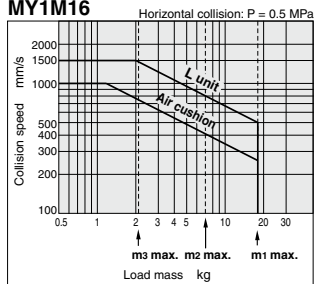

MY1M32

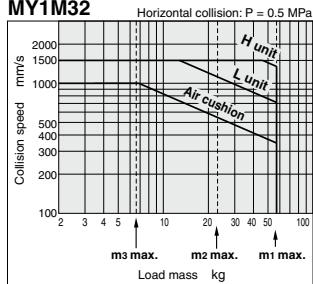

MY1M20

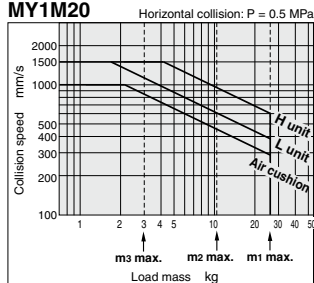

MY1M40

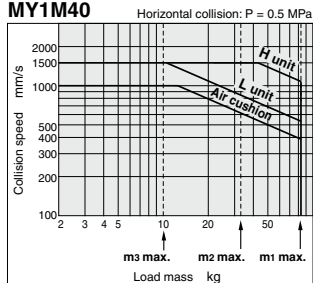

MY1M25

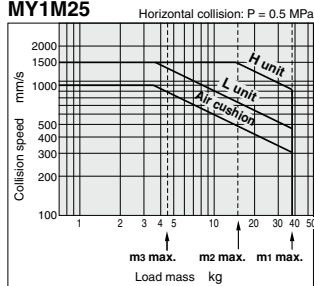

MY1M50

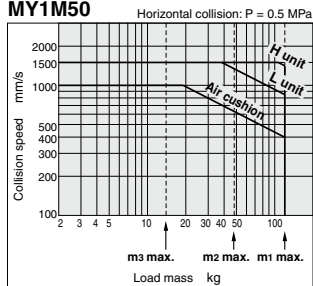

MY1M63

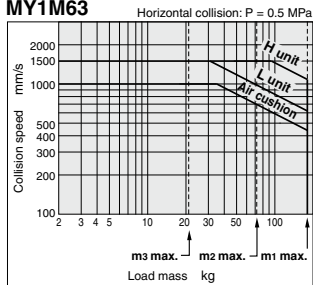

Tightening Torque for Stroke Adjusting Unit Holding Bolts (N·m)

Bore size (mm)	Unit	Tightening torque
16	A	0.7
	L	
20	A	1.8
	L	
	H	
25	A	3.5
	L	
	H	
32	A	5.8
	L	
	H	
40	A	13.8
	L	
	H	
50	A	13.8
	L	
	H	
63	A	27.5
	L	
	H	

Tightening Torque for Stroke Adjustment Unit Lock Plate Holding Bolts (N·m)

Bore size (mm)	Unit	Tightening torque
25	L	1.2
	H	3.3
32	L	3.3
	H	10
40	L	3.3
	H	10

Calculation of Absorbed Energy for Stroke Adjusting Unit with Shock Absorber (N·m)

Type of impact	Horizontal collision	Vertical (Downward)	Vertical (Upward)
Kinetic energy E ₁	$\frac{1}{2} m \cdot v^2$		
Thrust energy E ₂	$F \cdot s$	$F \cdot s + m \cdot g \cdot s$	$F \cdot s - m \cdot g \cdot s$
Absorbed energy E	$E_1 + E_2$		

Symbol
 v: Speed of impact object (m/s)
 F: Cylinder thrust (N)
 s: Shock absorber stroke (m)
 m: Mass of impact object (kg)
 g: Gravitational acceleration (9.8 m/s²)

Note) The speed of the impact object is measured at the time of impact with the shock absorber.

⚠ Precautions

Be sure to read before handling. Refer to front matter 57 for Safety Instructions and pages 3 to 12 for Actuator and Auto Switch Precautions.

⚠ Caution

Use caution not to get your hands caught in the unit.

- When using a product with stroke adjustment unit, the space between the slide table (slider) and the stroke adjustment unit becomes narrow at the stroke end, causing a danger of hands getting caught. Install a protective cover to prevent direct contact with the human body.

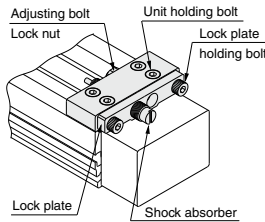

<Fastening of unit>
 The unit can be secured by evenly tightening the four unit holding bolts.

⚠ Caution

Do not operate with the stroke adjustment unit fixed in an intermediate position.

When the stroke adjustment unit is fix in an intermediate position, slippage can occur depending on the amount of energy released at the time of an impact. In such cases, as a stroke adjustment unit with the spacer for intermediate securing is available, it is recommended to use it. For other lengths, please consult with SMC (Refer to "Tightening Torque for Stroke Adjusting Unit Holding Bolts".)

<Stroke adjustment with adjustment bolt>
 Loosen the adjustment bolt lock nut, and adjust the stroke from the lock plate side using a hexagon wrench. Retighten the lock nut.

<Stroke adjustment with shock absorber>
 Loosen the two lock plate holding bolts, turn the shock absorber and adjust the stroke. Then, uniformly tighten the lock plate holding bolts to secure the shock absorber.

Take care not to over-tighten the holding bolts. (Except ø16, ø20, ø50, ø63) (Refer to "Tightening Torque for Stroke Adjusting Unit Lock Plate Holding Bolts".)

Note) Although the lock plate may slightly bend due to tightening of the lock plate holding bolt, this does not affect the shock absorber and locking function.

MY1B
-Z

MY1H
-Z

MY1B

MY1M

MY1C

MY1H

MY1
HT

MY1
□W

MY2C

MY2
□H

MY3A
MY3B

MY3M

D-□

-X□

Technical
data

Series MY1M

Construction: $\varnothing 16$ to $\varnothing 63$

MY1M16 to 63

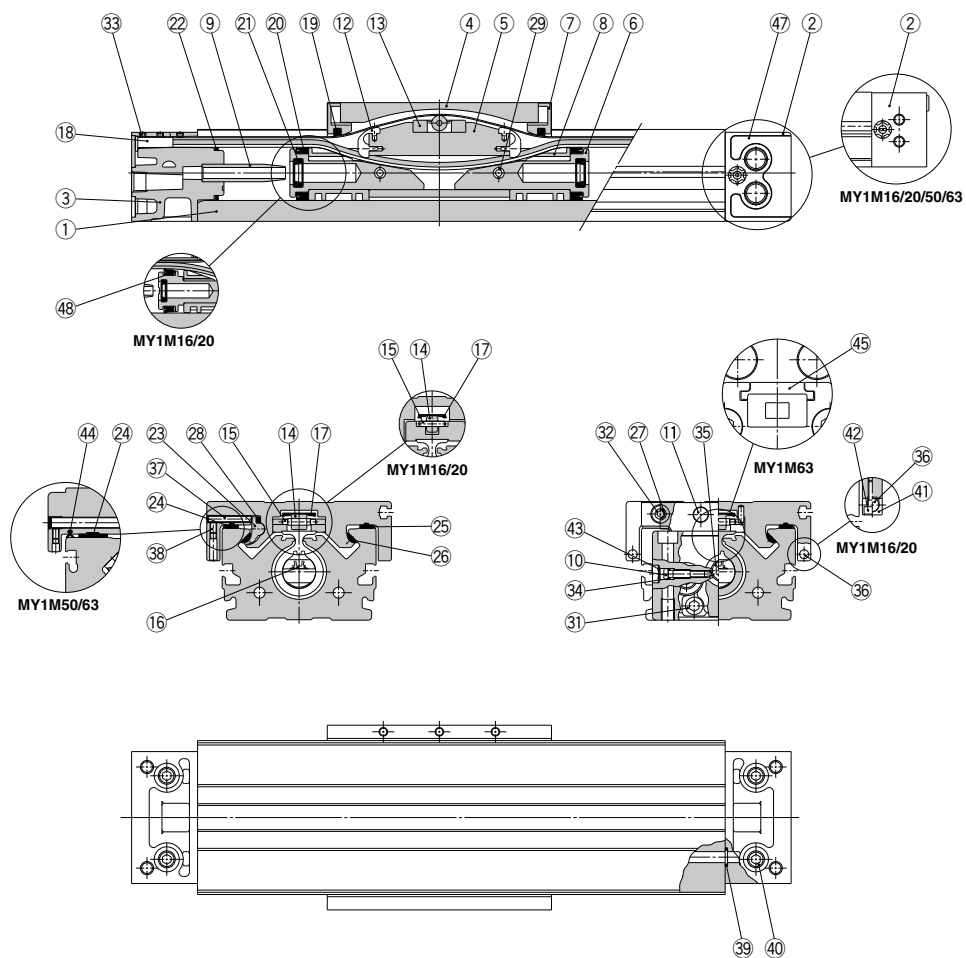

MY1M16 to 63

Component Parts

No.	Description	Material	Note
1	Cylinder tube	Aluminum alloy	Hard anodized
2	Head cover WR	Aluminum alloy	Painted
3	Head cover WL	Aluminum alloy	Painted
4	Slide table	Aluminum alloy	Hard anodized
5	Piston yoke	Aluminum alloy	Chromated
6	Piston	Aluminum alloy	Chromated
7	End cover	Special resin	
8	Wear ring	Special resin	
9	Cushion ring	Aluminum alloy	Anodized
10	Cushion needle	Rolled steel	Nickel plated
11	Stopper	Carbon steel	Nickel plated
12	Belt separator	Special resin	
13	Coupler	Sintered iron material	
14	Guide roller	Special resin	
15	Guide roller shaft	Stainless steel	
18	Belt clamp	Special resin	
23	Adjusting arm	Aluminum alloy	Chromated
24	Bearing R	Special resin	
25	Bearing L	Special resin	
26	Bearing S	Special resin	

No.	Description	Material	Note
27	Spacer	Stainless steel	
28	Backup spring	Stainless steel	
29	Spring pin	Carbon tool steel	
31	Hexagon socket head cap screw	Chromium molybdenum steel	Nickel plated
32	Hexagon socket button head screw	Chromium molybdenum steel	Nickel plated
33	Hexagon socket head set screw	Chromium molybdenum steel	Black zinc chromated/Nickel plated
35	Hexagon socket head taper plug	Carbon steel	Nickel plated
36	Magnet	—	
37	Hexagon socket head set screw	Chromium molybdenum steel	Black zinc chromated
38	Hexagon socket head set screw	Chromium molybdenum steel	Black zinc chromated
40	Hexagon socket head taper plug	Carbon steel	Nickel plated
41	Magnet holder	Special resin	($\phi 16, \phi 20$)
42	Hexagon socket head cap screw	Chromium molybdenum steel	Nickel plated
43	Type CR retaining ring	Spring steel	
45	Head plate	Aluminum alloy	Hard anodized ($\phi 63$)
47	Port cover	Special resin	($\phi 25$ to $\phi 40$)
48	Lube retainer	Special resin	($\phi 16, \phi 20$)

Replacement Part: Seal Kit

No.	Description	Qty.	MY1M16	MY1M20	MY1M25	MY1M32	MY1M40	MY1M50	MY1M63
16	Seal belt	1	MY16-16A-Stroke	MY20-16A-Stroke	MY25-16A-Stroke	MY32-16A-Stroke	MY40-16A-Stroke	MY50-16A-Stroke	MY63-16A-Stroke
17	Dust seal band	1	MY16-16B-Stroke	MY20-16B-Stroke	MY25-16B-Stroke	MY32-16B-Stroke	MY40-16B-Stroke	MY50-16B-Stroke	MY63-16B-Stroke
34	O-ring	2	KA00309 ($\phi 4 \times \phi 1.8 \times \phi 1.1$)	KA00311 ($\phi 5.1 \times \phi 3 \times \phi 1.05$)	KA00311 ($\phi 5.1 \times \phi 3 \times \phi 1.05$)	KA00320 ($\phi 7.15 \times \phi 3.75 \times \phi 1.7$)	KA00402 ($\phi 8.3 \times \phi 4.5 \times \phi 1.9$)	KA00777 —	KA00777 —
44	Side scraper	2	—	—	—	—	—	MYM50-15CK0502B	MYM63-15CK0503B
19	Scraper	2	—	—	—	—	—	—	—
20	Piston seal	2	—	—	—	—	—	—	—
21	Cushion seal	2	MY1M16-PS	MY1M20-PS	MY1M25-PS	MY1M32-PS	MY1M40-PS	MY1M50-PS	MY1M63-PS
22	Tube gasket	2	—	—	—	—	—	—	—
39	O-ring	4	—	—	—	—	—	—	—

* Seal kit includes 19, 20, 21, 22 and 39. Order the seal kit based on each bore size.

* Seal kit includes a grease pack (10 g).

When 16 and 17 are shipped independently, a grease pack is included. (10 g per 1000 strokes)

Order with the following part number when only the grease pack is needed.

Grease pack part number: GR-S-010 (10 g), GR-S-020 (20 g)

Note) Two kinds of dust seal bands are available. Verify the type to use, since the part number varies depending on the treatment of the hexagon socket head set screw 33.

A: Black zinc chromated→MY□□-16B-stroke, B: Nickel plated→MY□□-16BW-stroke

MY1B
-Z

MY1H
-Z

MY1B

MY1M

MY1C

MY1H

MY1
HT

MY1
□W

MY2C

MY2
□

MY3A
MY3B

MY3M

D-□

-X□

Technical
data

Series MY1M

Standard Type/Centralized Piping Type $\phi 16, \phi 20$

Refer to page 1325 regarding centralized piping port variations.

MY1M16□/20□ — Stroke

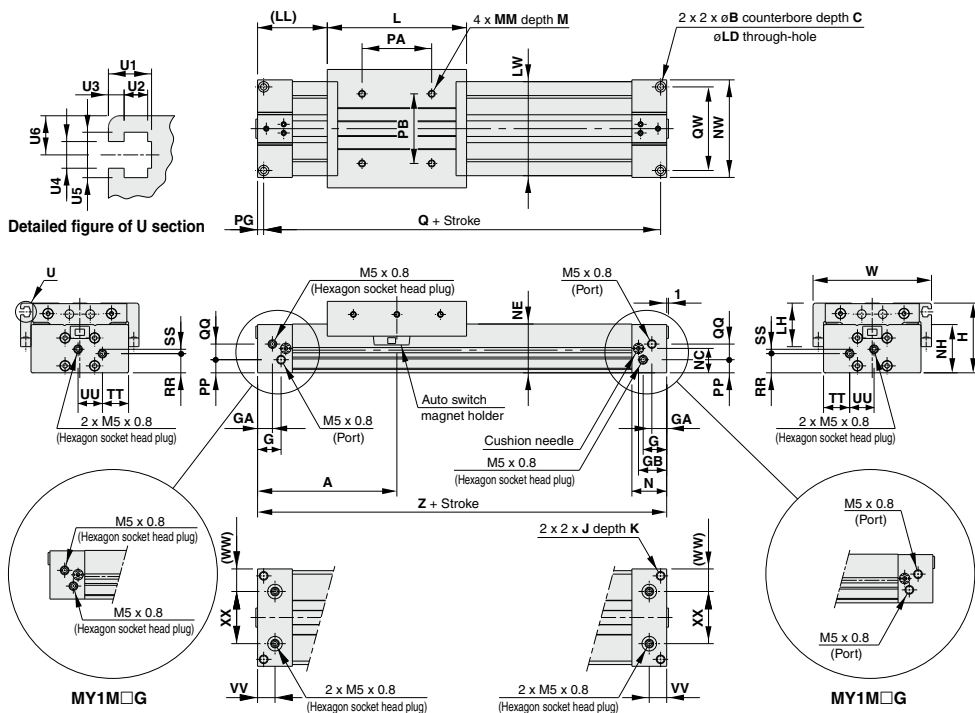

Model	A	B	C	G	GA	GB	H	J	K	L	LD	LH	LL	LW	M	MM	N	NC	NE	NH	NW	PA
MY1M16□	80	6	3.5	13.5	8.5	16.2	40	M5 x 0.8	10	80	3.6	22.5	40	54	6	M4 x 0.7	20	14	28	27.7	56	40
MY1M20□	100	7.5	4.5	12.5	12.5	20	46	M6 x 1	12	100	4.8	23	50	58	7.5	M5 x 0.8	25	17	34	33.7	60	50

Model	PB	PG	PP	Q	QQ	QW	RR	SS	TT	UU	VV	W	WW	XX	Z
MY1M16□	40	3.5	7.5	153	9	48	11	2.5	15	14	10	68	13	30	160
MY1M20□	40	4.5	11.5	191	10	45	14.5	5	18	12	12.5	72	14	32	200

Detailed Dimensions of U Section (mm)

Model	U1	U2	U3	U4	U5	U6
MY1M16□	5.5	3	2	3.4	5.8	5
MY1M20□	5.5	3	2	3.4	5.8	5.5

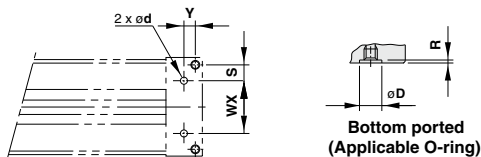

Hole Size for Centralized Piping on the Bottom

Model	WX	Y	S	d	D	R	Applicable O-ring
MY1M16□	30	6.5	9	4	8.4	1.1	C6
MY1M20□	32	8	6.5	4	8.4	1.1	

(Machine the mounting side to the dimensions below.)

Mechanically Jointed Rodless Cylinder Slide Bearing Guide Type **Series MY1M**

Standard Type/Centralized Piping Type $\phi 25, \phi 32, \phi 40$ Refer to page 1325 regarding centralized piping port variations.

MY1M25□/32□/40□ — Stroke

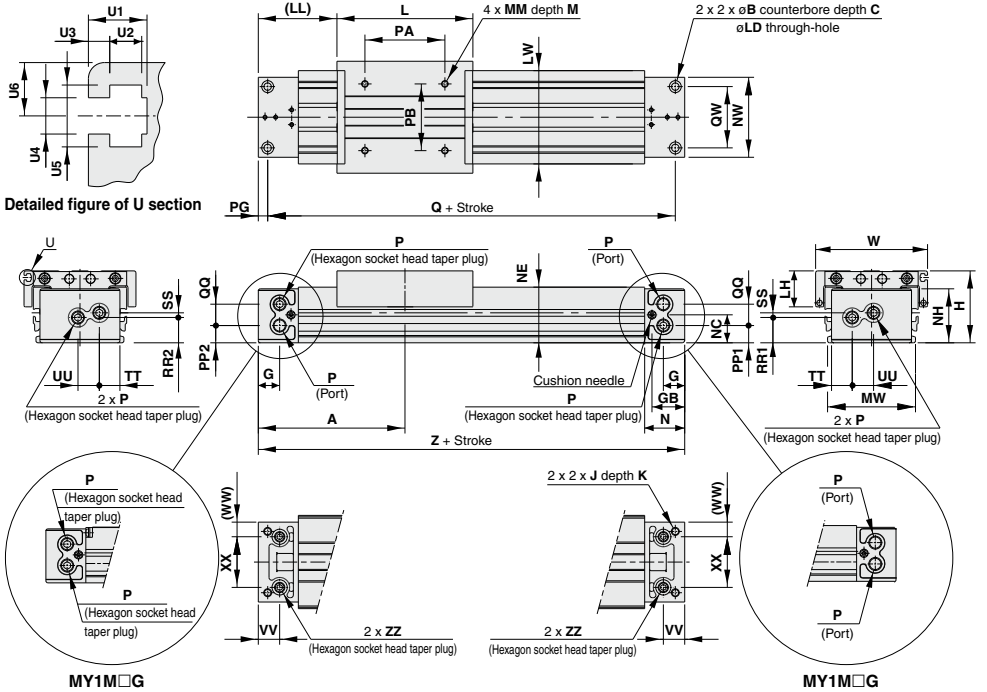

Model	A	B	C	G	GB	H	J	K	L	LD	LH	LL	LW	M	MM	MW	N	NC	NE	NH	NW	P	PA
MY1M25□	110	9	5.5	17	24.5	54	M6 x 1	9.5	102	5.6	27	59	70	10	M5 x 0.8	66	30	21	41.8	40.5	60	Rc1/8	80
MY1M32□	140	11	6.5	19	30	68	M8 x 1.25	16	132	6.8	35	74	88	13	M6 x 1	80	37	26	52.3	50	74	Rc1/8	80
MY1M40□	170	14	8.5	23	36.5	84	M10 x 1.5	15	162	8.6	38	89	104	13	M6 x 1	96	45	32	65.3	63.5	94	Rc1/4	100

(mm)

P indicates cylinder supply ports.

Model	Detailed Dimensions of U Section (mm)														Detailed Dimensions of U Section (mm)										
	PB	PG	PP1	PP2	Q	QQ	QW	RR1	RR2	SS	TT	UU	VV	W	WW	XX	Z	ZZ	Model	U1	U2	U3	U4	U5	U6
MY1M25□	50	7	12.7	12.7	206	15.5	46	18.9	17.9	4.1	15.5	16	16	84	11	38	220	Rc 1/16	MY1M25□	5.5	3	2	3.4	5.8	5
MY1M32□	60	8	15.5	18.5	264	16	60	22	24	4	21	16	19	102	13	48	280	Rc 1/16	MY1M32□	5.5	3	2	3.4	5.8	7
MY1M40□	80	9	17.5	20	322	26	72	25.5	29	9	26	21	23	118	20	54	340	Rc 1/8	MY1M40□	6.5	3.8	2	4.5	7.3	8

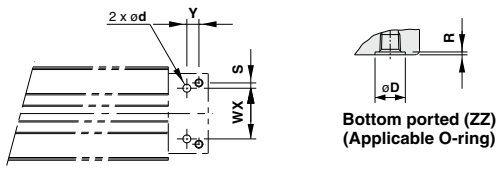

Hole Size for Centralized Piping on the Bottom

Model	WX	Y	S	d	D	R	Applicable O-ring
MY1M25□	38	9	4	6	11.4	1.1	C9
MY1M32□	48	11	6	6	11.4	1.1	
MY1M40□	54	14	9	8	13.4	1.1	C11.2

(Machine the mounting side to the dimensions below.)

- MY1B-Z
- MY1H-Z
- MY1B
- MY1M
- MY1C
- MY1H
- MY1HT
- MY1□W
- MY2C
- MY2H□
- MY3A
- MY3B
- MY3M

- D-□
- X□
- Technical data

Series MY1M

Standard Type/Centralized Piping Type $\phi 50, \phi 63$

Refer to page 1325 regarding centralized piping port variations.

MY1M50□/60□ — Stroke

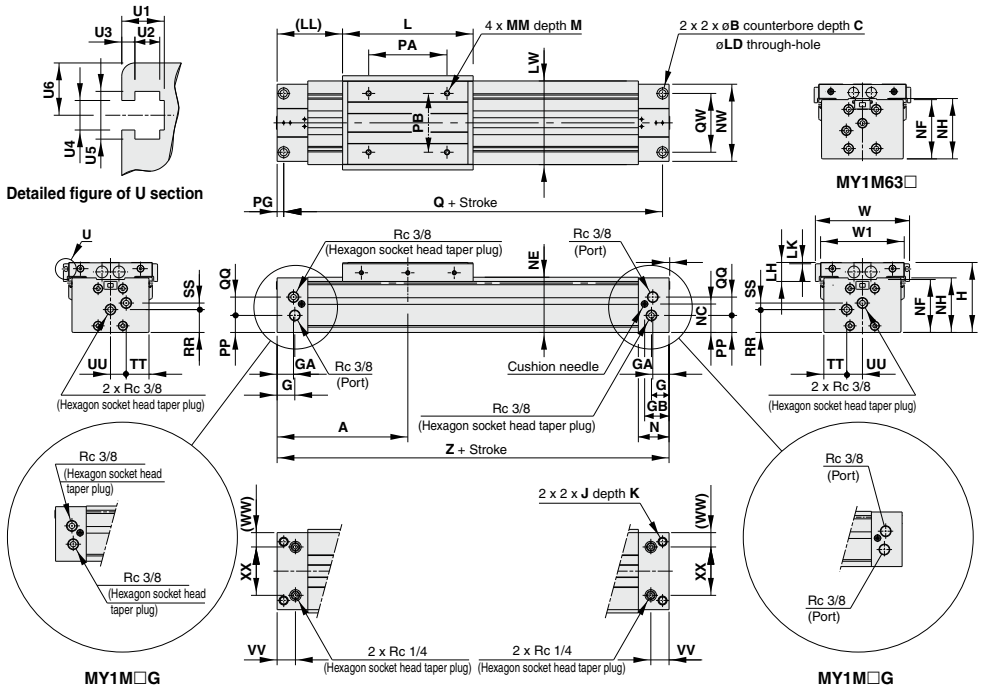

Model	A	B	C	G	GA	GB	H	J	K	L	LD	LH	LK	LL	LW	M	MM	N	NC	NE	NF	NH	NW	PA
MY1M50□	200	17	10.5	27	25	37.5	107	M14 x 2	28	200	11	29	2	100	128	15	M8 x 1.25	47	43.5	84.5	81	83.5	118	120
MY1M63□	230	19	12.5	29.5	27.5	39.5	130	M16 x 2	32	230	13.5	32.5	5.5	115	152	16	M10 x 1.5	50	56	104	103	105	142	140

Model	PB	PG	PP	Q	QQ	QW	RR	SS	TT	UU	VV	W	W1	WW	XX	Z
MY1M50□	90	10	26	380	28	90	35	10	35	24	28	144	128	22	74	400
MY1M63□	110	12	42	436	30	110	49	13	43	28	30	168	152	25	92	460

Detailed Dimensions of U Section

Model	U1	U2	U3	U4	U5	U6
MY1M50□	6.5	3.8	2	4.5	7.3	8
MY1M63□	8.5	5	2.5	5.5	8.4	8

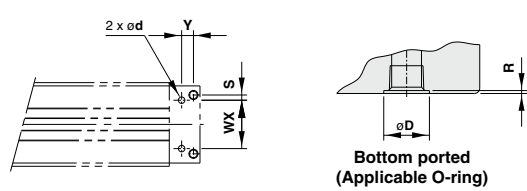

Bottom ported (Applicable O-ring)

Hole Size for Centralized Piping on the Bottom

Model	WX	Y	S	d	D	R	Applicable O-ring
MY1M50□	74	18	8	10	17.5	1.1	C15
MY1M63□	92	18	9	10	17.5	1.1	

(Machine the mounting side to the dimensions below.)

Stroke Adjustment Unit

With adjustment bolt

MY1M Bore size — Stroke **A**

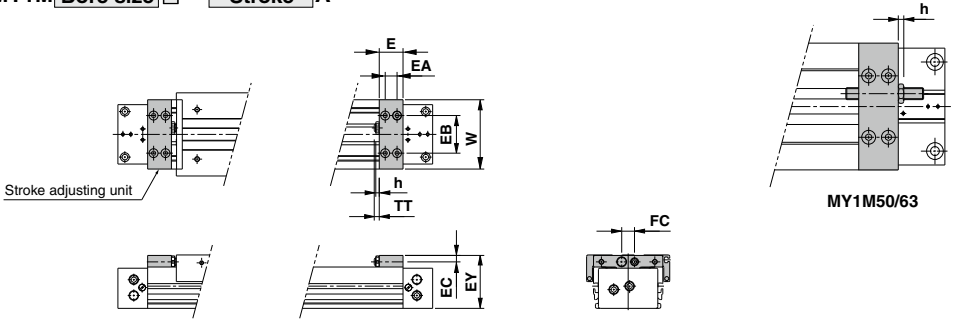

Applicable bore size	E	EA	EB	EC	EY	FC	h	TT	W
MY1M16	14.6	7	30	5.8	39.5	14	3.6	5.4 (Max. 11)	58
MY1M20	20	10	32	5.8	45.5	14	3.6	5 (Max. 11)	58
MY1M25	24	12	38	6.5	53.5	13	3.5	5 (Max. 16.5)	70
MY1M32	29	14	50	8.5	67	17	4.5	8 (Max. 20)	88
MY1M40	35	17	57	10	83	17	4.5	9 (Max. 25)	104
MY1M50	40	20	66	14	106	26	5.5	13 (Max. 33)	128
MY1M63	52	26	77	14	129	31	5.5	13 (Max. 38)	152

With low load shock absorber + Adjustment bolt

MY1M Bore size — Stroke **L**

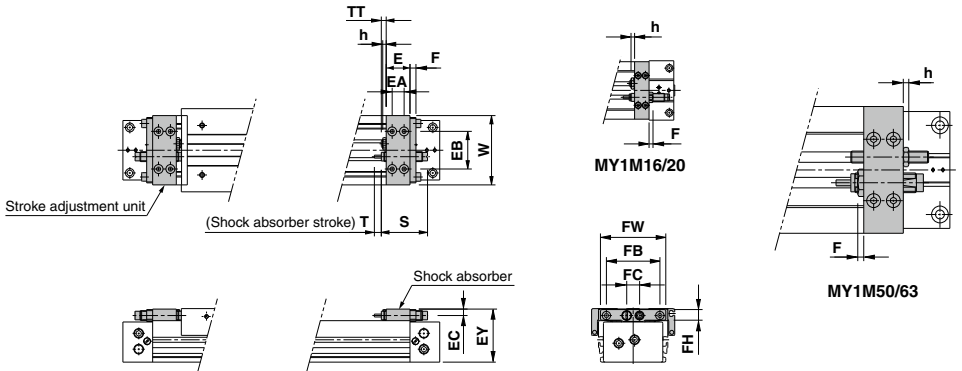

Applicable size	E	EA	EB	EC	EY	F	FB	FC	FH	FW	h	S	T	TT	W	Shock absorber model
MY1M16	14.6	7	30	5.8	39.5	4	—	14	—	—	3.6	40.8	6	5.4 (Max. 11)	58	RB0806
MY1M20	20	10	32	5.8	45.5	4	—	14	—	—	3.6	40.8	6	5 (Max. 11)	58	RB0806
MY1M25	24	12	38	6.5	53.5	6	54	13	13	66	3.5	46.7	7	5 (Max. 16.5)	70	RB1007
MY1M32	29	14	50	8.5	67	6	67	17	16	80	4.5	67.3	12	8 (Max. 20)	88	RB1412
MY1M40	35	17	57	10	83	6	78	17	17.5	91	4.5	67.3	12	9 (Max. 25)	104	RB1412
MY1M50	40	20	66	14	106	6	—	26	—	—	5.5	73.2	15	13 (Max. 33)	128	RB2015
MY1M63	52	26	77	14	129	6	—	31	—	—	5.5	73.2	15	13 (Max. 38)	152	RB2015

- MY1B
- Z
- MY1H
- Z
- MY1B
- MY1M
- MY1C
- MY1H
- MY1
- HT
- MY1
- W
- MY2C
- MY2
- H
- MY3A
- MY3B
- MY3M

- D
- X
- Technical data

Series MY1M

Stroke Adjustment Unit

With high load shock absorber + Adjustment bolt

MY1M — H

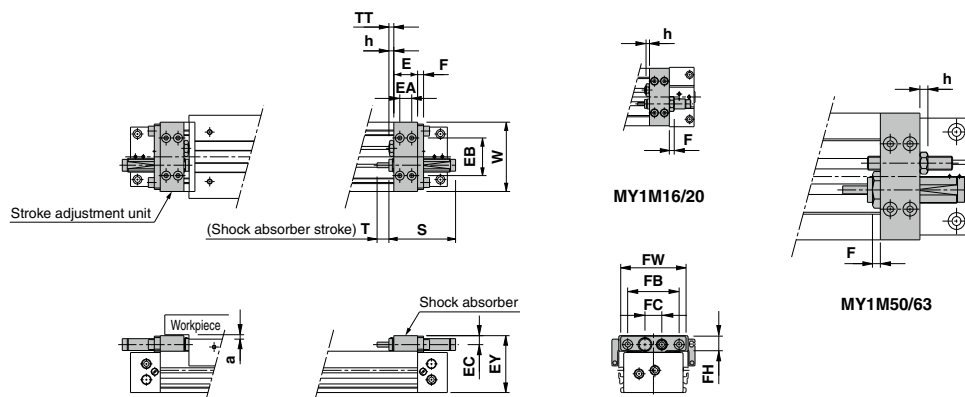

* Since dimension EY of the H type unit is greater than the table top height (dimension H), when mounting a workpiece that exceeds the overall length (dimension L) of the slide table, allow a clearance of dimension "a" or larger on the workpiece side.

Applicable bore size	E	EA	EB	EC	EY	F	FB	FC	FH	FW	h	S	T	TT	W	Shock absorber model	a
MY1M20	20	10	32	7.7	50	5	—	14	—	—	3.5	46.7	7	5 (Max. 11)	58	RB1007	5
MY1M25	24	12	38	9	57.5	6	52	17	16	66	4.5	67.3	12	5 (Max. 16.5)	70	RB1412	4.5
MY1M32	29	14	50	11.5	73	8	67	22	22	82	5.5	73.2	15	8 (Max. 20)	88	RB2015	6
MY1M40	35	17	57	12	87	8	78	22	22	95	5.5	73.2	15	9 (Max. 25)	104	RB2015	4
MY1M50	40	20	66	18.5	115	8	—	30	—	—	11	99	25	13 (Max. 33)	128	RB2725	9
MY1M63	52	26	77	19	138.5	8	—	35	—	—	11	99	25	13 (Max. 38)	152	RB2725	9.5

Side Support

Side support A MY-S□A

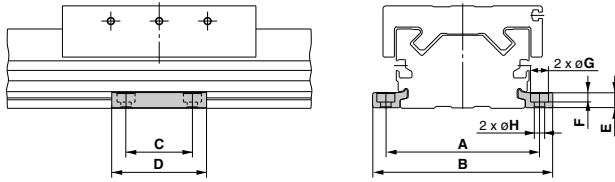

Side support B MY-S□B

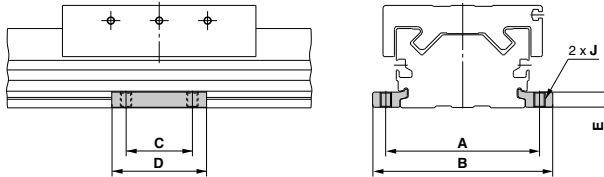

Model	Applicable bore size	A	B	C	D	E	F	G	H	J
MY-S16 ^A _B	MY1M16	61	71.6	15	26	4.9	3	6.5	3.4	M4 x 0.7
MY-S20 ^A _B	MY1M20	67	79.6	25	38	6.4	4	8	4.5	M5 x 0.8
MY-S25 ^A _B	MY1M25	81	95	35	50	8	5	9.5	5.5	M6 x 1
MY-S32 ^A _B	MY1M32	100	118	45	64	11.7	6	11	6.6	M8 x 1.25
MY-S40 ^A _B	MY1M40	120	142	55	80	14.8	8.5	14	9	M10 x 1.5
MY-S63 ^A _B	MY1M63	172	202	70	100	18.3	10.5	17.5	11.5	M12 x 1.75

* A set of side supports consists of a left support and a right support.

Guide for Side Support Application

For long stroke operation, the cylinder tube may be deflected depending on its own weight and the load mass. In such a case, use a side support in the middle section. The spacing (L) of the support must be no more than the values shown in the graph on the right.

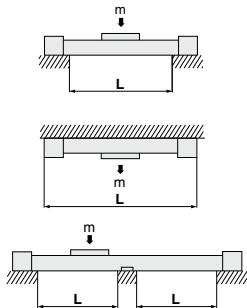

⚠ Caution

1. If the cylinder mounting surfaces are not measured accurately, using a side support may cause poor operation. Therefore, be sure to level the cylinder tube when mounting. Also, for long stroke operation involving vibration and impact, use of a side support is recommended even if the spacing value is within the allowable limits shown in the graph.
2. Support brackets are not for mounting; use them solely for providing support.

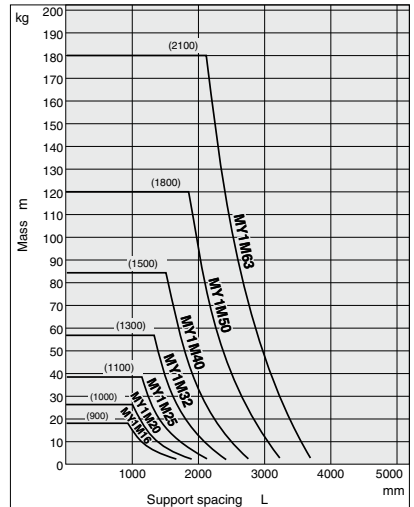

MY1B

-Z

MY1H

-Z

MY1B

MY1M

MY1C

MY1H

-Z

MY1

HT

MY1

□W

MY2C

MY2

□H

MY3A

MY3B

MY3M

MY3M

MY3M

MY3M

MY3M

MY3M

MY3M

MY3M

MY3M

MY3M

MY3M

MY3M

MY3M

MY3M

MY3M

MY3M

MY3M

MY3M

MY3M

MY3M

MY3M

MY3M

MY3M

MY3M

MY3M

MY3M

MY3M

MY3M

MY3M

Series MY1C

Cam Follower Guide Type

ø16, ø20, ø25, ø32, ø40, ø50, ø63

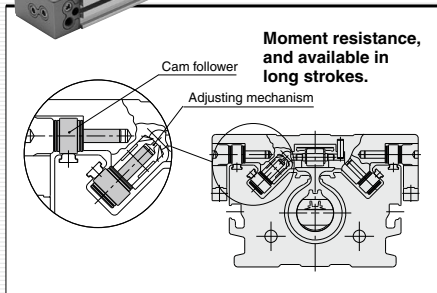
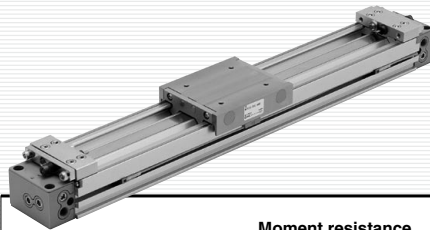

MY1B
-Z

MY1H
-Z

MY1B

MY1M

MY1C

MY1H

MY1
HT

MY1
□W

MY2C

MY2
H□

MY3A
MY3B

MY3M

D-□

-X□

Technical
data

Series MY1C Prior to Use

Maximum Allowable Moment/Maximum Load Mass

Model	Bore size (mm)	Maximum allowable moment (N·m)			Maximum load mass (kg)		
		M1	M2	M3	m1	m2	m3
MY1C	16	6.0	3.0	2.0	18	7	2.1
	20	10	5.0	3.0	25	10	3
	25	15	8.5	5.0	35	14	4.2
	32	30	14	10	49	21	6
	40	60	23	20	68	30	8.2
	50	115	35	35	93	42	11.5
	63	150	50	50	130	60	16

The above values are the maximum allowable values for moment and load. Refer to each graph regarding the maximum allowable moment and maximum allowable load for a particular piston speed.

Load mass (kg)

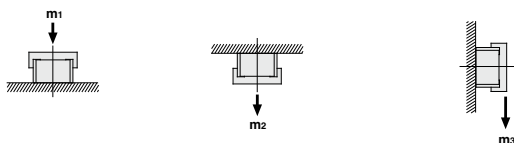

Moment (N·m)

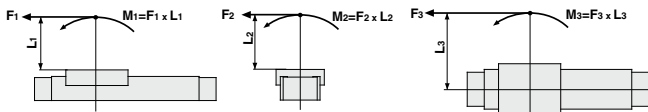

<Calculation of guide load factor>

- Maximum allowable load (1), static moment (2), and dynamic moment (3) (at the time of impact with stopper) must be examined for the selection calculations.
 ※ To evaluate, use \bar{v}_a (average speed) for (1) and (2), and v (collision speed $v = 1.4v_a$) for (3). Calculate m_{max} for (1) from the maximum allowable load graph (m_1, m_2, m_3) and M_{max} for (2) and (3) from the maximum allowable moment graph (M_1, M_2, M_3).

$$\text{Sum of guide load factors } \Sigma \alpha = \frac{\text{Load mass [m]}}{\text{Maximum allowable load [m}_{max}\text{]}} + \frac{\text{Static moment [M]}^{(1)}}{\text{Allowable static moment [M}_{max}\text{]}} + \frac{\text{Dynamic moment [M}\epsilon\text{]}^{(2)}}{\text{Allowable dynamic moment [M}\epsilon_{max}\text{]}} \leq 1$$

Note 1) Moment caused by the load, etc., with cylinder in resting condition.

Note 2) Moment caused by the impact load equivalent at the stroke end (at the time of impact with stopper).

Note 3) Depending on the shape of the workpiece, multiple moments may occur. When this happens, the sum of the load factors ($\Sigma \alpha$) is the total of all such moments.

2. Reference formula [Dynamic moment at impact]

Use the following formulae to calculate dynamic moment when taking stopper impact into consideration.

m: Load mass (kg)

F: Load (N)

F ϵ : Load equivalent to impact (at impact with stopper) (N)

\bar{v}_a : Average speed (mm/s)

M: Static moment (N·m)

$$v = 1.4\bar{v}_a \quad (\text{mm/s}) \quad F\epsilon = 1.4v_a \cdot \delta \cdot m \cdot g \quad (\text{Note 4})$$

$$\therefore M\epsilon = \frac{1}{3} \cdot F\epsilon \cdot L_1 = 4.57v_a \delta m L_1 \quad (\text{N}\cdot\text{m}) \quad (\text{Note 5})$$

v: Collision speed (mm/s)

L $_1$: Distance to the load's center of gravity (m)

M ϵ : Dynamic moment (N·m)

δ : Damper coefficient At collision: $v = 1.4v_a$

With rubber bumper = 4/100

(MY1B10, MY1H10)

With air cushion = 1/100

With shock absorber = 1/100

g: Gravitational acceleration (9.8 m/s²)

Note 4) $1.4v_a\delta$ is a dimensionless coefficient for calculating impact force.

Note 5) Average load coefficient ($= \frac{1}{3}$). This coefficient is for averaging the maximum load moment at the time of stopper impact according to service life calculations.

- For detailed selection procedures, refer to pages 1266 and 1267.

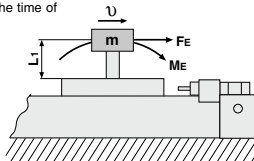

Maximum Allowable Moment

Select the moment from within the range of operating limits shown in the graphs. Note that the maximum allowable load value may sometimes be exceeded even within the operating limits shown in the graphs. Therefore, also check the allowable load for the selected conditions.

Maximum Load Mass

Select the load from within the range of limits shown in the graphs. Note that the maximum allowable moment value may sometimes be exceeded even within the operating limits shown in the graphs. Therefore, also check the allowable moment for the selected conditions.

MY1C/M₁

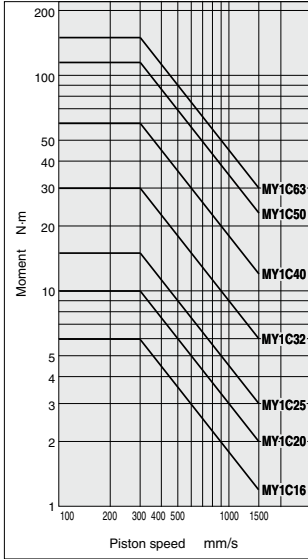

MY1C/M₂

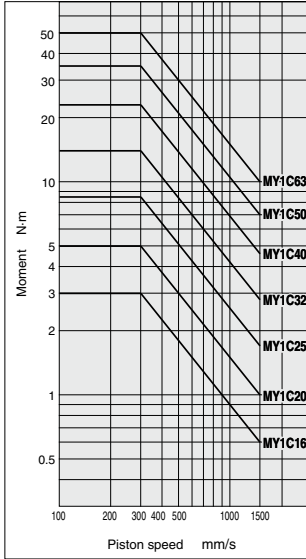

MY1C/M₃

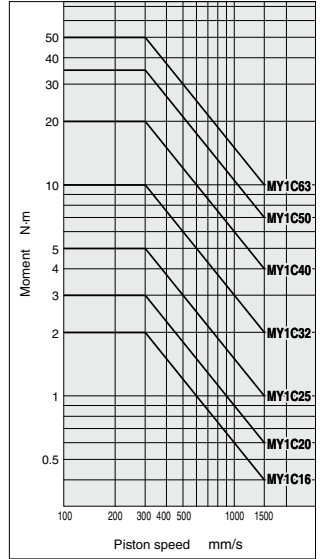

MY1C/m₁

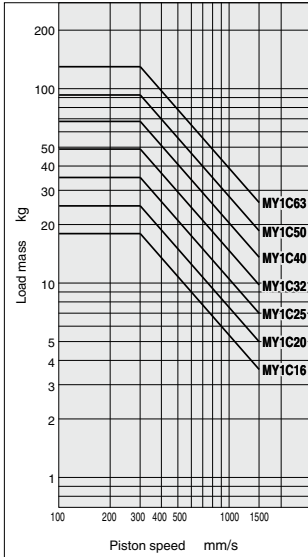

MY1C/m₂

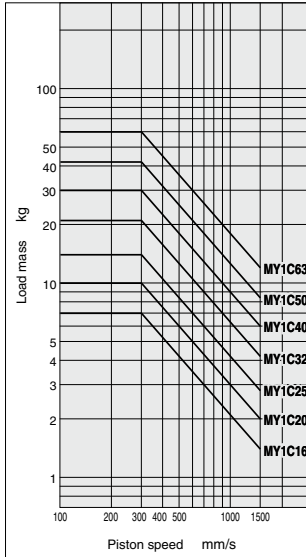

MY1C/m₃

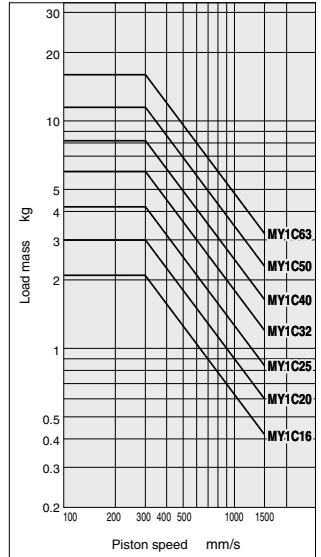

MY1B
-Z

MY1H
-Z

MY1B

MY1M

MY1C

MY1H

MY1
HT

MY1
W

MY2C

MY2
H

MY3A

MY3B

MY3M

D-

-X

Technical
data

Series MY1C Model Selection

Following are the steps for selecting the most suitable Series MY1C to your application.

Calculation of Guide Load Factor

1. Operating Conditions

Cylinder..... MY1C40-500
Average operating speed v_a ... 300 mm/s
Mounting orientation..... Ceiling mounting
Cushion..... Air cushion
($\delta = 1/100$)

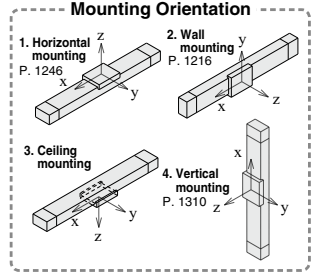
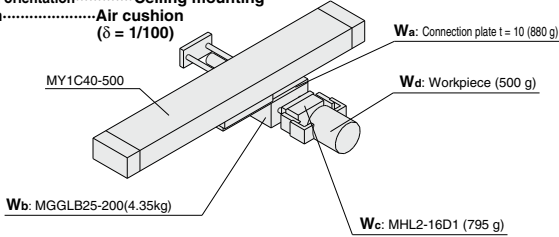

For actual examples of calculation for each orientation, refer to the pages above.

2. Load Blocking

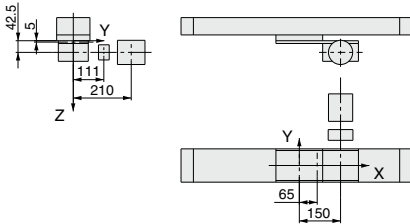

Mass and Center of Gravity for Each Workpiece

Workpiece no. W_n	Mass m_n	Center of gravity		
		X-axis X_n	Y-axis Y_n	Z-axis Z_n
W_a	0.88 kg	65 mm	0 mm	5 mm
W_b	4.35 kg	150 mm	0 mm	42.5 mm
W_c	0.795 kg	150 mm	111 mm	42.5 mm
W_d	0.5 kg	150 mm	210 mm	42.5 mm

$n=a, b, c, d$

3. Composite Center of Gravity Calculation

$$m_2 = \sum m_n \\ = 0.88 + 4.35 + 0.795 + 0.5 = 6.525 \text{ kg}$$

$$X = \frac{1}{m_2} \times \sum (m_n \times X_n) \\ = \frac{1}{6.525} (0.88 \times 65 + 4.35 \times 150 + 0.795 \times 150 + 0.5 \times 150) = 138.5 \text{ mm}$$

$$Y = \frac{1}{m_2} \times \sum (m_n \times Y_n) \\ = \frac{1}{6.525} (0.88 \times 0 + 4.35 \times 0 + 0.795 \times 111 + 0.5 \times 210) = 29.6 \text{ mm}$$

$$Z = \frac{1}{m_2} \times \sum (m_n \times Z_n) \\ = \frac{1}{6.525} (0.88 \times 5 + 4.35 \times 42.5 + 0.795 \times 42.5 + 0.5 \times 42.5) = 37.4 \text{ mm}$$

4. Calculation of Load Factor for Static Load

m_2 : Mass

$$m_2 \text{ max (from (1) of graph MY1C}/m_2) = 30 \text{ (kg)}$$

$$\text{Load factor } \alpha_1 = m_2 / m_2 \text{ max} = 6.525 / 30 = 0.22$$

M_1 : Moment

$$M_1 \text{ max (from (2) of graph MY1C}/M_1) = 60 \text{ (N}\cdot\text{m)}$$

$$M_1 = m_2 \times g \times X = 6.525 \times 9.8 \times 138.5 \times 10^{-3} = 8.86 \text{ (N}\cdot\text{m)}$$

$$\text{Load factor } \alpha_2 = M_1 / M_1 \text{ max} = 8.86 / 60 = 0.15$$

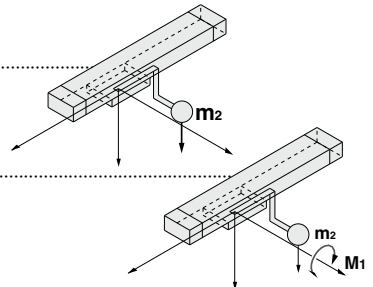

M₂: Moment

M₂ max (from (3) of graph MY1C/M₂) = 23.0 (N·m).....

M₂ = m₂ × g × Y = 6.525 × 9.8 × 29.6 × 10⁻³ = 1.89 (N·m)

Load factor **α₃ = M₂/M₂ max** = 1.89/23.0 = **0.08**

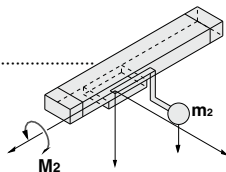

5. Calculation of Load Factor for Dynamic Moment

Equivalent load F_E at impact

$$F_E = 1.4v_a \times \delta \times m \times g = 1.4 \times 300 \times \frac{1}{100} \times 6.525 \times 9.8 = 268.6 \text{ (N)}$$

M_{1E}: Moment

M_{1E} max (from (4) of graph MY1C/M₁ where 1.4v_a = 420 mm/s) = 42.9 (N·m).....

$$M_{1E} = \frac{1}{3} \times F_E \times Z = \frac{1}{3} \times 268.6 \times 37.4 \times 10^{-3} = 3.35 \text{ (N·m)}$$

Load factor **α₄ = M_{1E}/M_{1E} max** = 3.35/42.9 = **0.08**

M_{3E}: Moment

M_{3E} max (from (5) of graph MY1C/M₃ where 1.4v_a = 420 mm/s) = 14.3 (N·m).....

$$M_{3E} = \frac{1}{3} \times F_E \times Y = \frac{1}{3} \times 268.6 \times 29.6 \times 10^{-3} = 2.65 \text{ (N·m)}$$

Load factor **α₅ = M_{3E}/M_{3E} max** = 2.65/14.3 = **0.19**

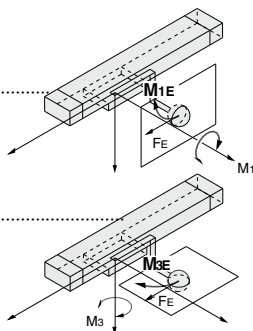

6. Sum and Examination of Guide Load Factors

$$\sum \alpha = \alpha_1 + \alpha_2 + \alpha_3 + \alpha_4 + \alpha_5 = 0.72 \leq 1$$

The above calculation is within the allowable value, and therefore the selected model can be used.

Select a shock absorber separately.

In an actual calculation, when the total sum of guide load factors α in the formula above is more than 1, consider either decreasing the speed, increasing the bore size, or changing the product series. This calculation can be easily made using the "SMC Pneumatics CAD System".

MY1B
-Z

MY1H
-Z

MY1B

MY1M

MY1C

MY1H

MY1
HT

MY1
□W

MY2C

MY2
□H

MY3A

MY3B

MY3M

Load Mass

MY1C/m₂

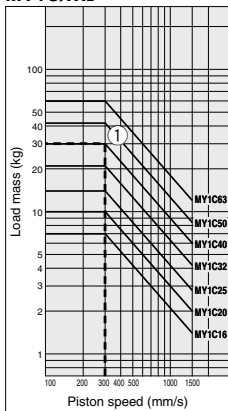

Allowable Moment

MY1C/M₁

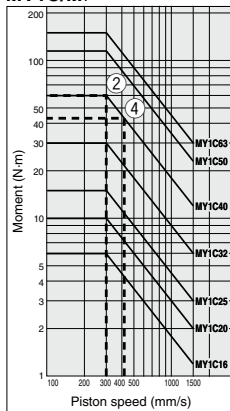

MY1C/M₂

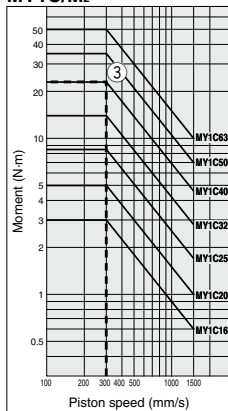

MY1C/M₃

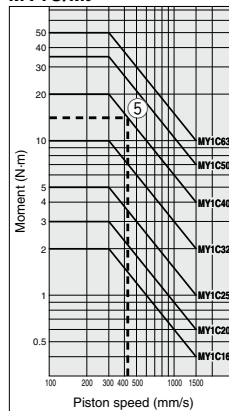

D-□

-X□

Technical
data

Mechanically Jointed Rodless Cylinder Cam Follower Guide Type

Series MY1C

ø16, ø20, ø25, ø32, ø40, ø50, ø63

How to Order

Cam follower guide type

MY1C 25 - **300** - **M9BW**

Cam follower guide type

Bore size

16	16 mm
20	20 mm
25	25 mm
32	32 mm
40	40 mm
50	50 mm
63	63 mm

Port thread type

Symbol	Type	Bore size
Nil	M thread	ø16, ø20
	Rc	ø25, ø32,
TN	NPT	ø40, ø50,
TF	G	ø63

Piping

Nil	Standard type
G	Centralized piping type

Cylinder stroke (mm)

Bore size (mm)	Standard stroke (mm)*	Maximum manufacturable stroke (mm)
16	100, 200, 300, 400, 500, 600, 700	3000
20, 25, 32	800, 900, 1000, 1200, 1400, 1600	5000
40, 50, 63	1800, 2000	

* The stroke can be manufactured up to the maximum stroke from 1 mm stroke in 1 mm increments. However, when the stroke is 49 mm or less, the air cushion capability lowers and multiple auto switches cannot be mounted. Pay special attention to this point. Also when exceeding a 2000 mm stroke, specify "XB1" at the end of the model number. For details, refer to the "Made to Order Specifications"

Made to Order
Refer to page 1269 for details.

Number of auto switches

Nil	2 pcs.
S	1 pc.
n	"n" pcs.

Auto switch

Nil	Without auto switch (Built-in magnet)
-----	---------------------------------------

Applicable auto switches vary depending on the bore size. Select an applicable one referring to the table below.

Stroke adjustment unit symbol
Refer to "Stroke adjustment unit" on page 1269.

Applicable Auto Switches

Refer to pages 1559 to 1673 for further information on auto switches.

Type	Special function	Electrical entry	Indicator light	Wiring (Output)	Load voltage		Auto switch model		Lead wire length (m)				Pre-wired connector	Applicable load		
					DC	AC	Perpendicular ø16, ø20 ø25 to ø63	In-line ø16, ø20 ø25 to ø63	0.5 (Nil)	1 (M)	3 (L)	5 (Z)				
Solid state auto switch	Diagnostic indication (2-color indication)	Grommet	Yes	3-wire (PNP)	24 V	5 V, 12 V	M9NV	M9N	●	●	●	○	○	IC circuit	Relay, PLC	
				3-wire (PNP)			M9PV	M9P	●	●	●	○	○			
				2-wire			M9BV	M9B	●	●	●	○	○			—
				3-wire (NPN)			M9NVV	M9NW	●	●	●	○	○			IC circuit
	Water resistant (2-color indication)			3-wire (PNP)	5 V, 12 V	M9PWW	M9PW	●	●	●	○	○	IC circuit			
				2-wire		M9BWW	M9BW	●	●	●	○	○		—		
				3-wire (NPN)		M9NAV**	M9NA**	○	○	○	○	○		—		
				3-wire (PNP)		M9PAV**	M9PA**	○	○	○	○	○		—		
Reed auto switch	Grommet	No	2-wire	24 V	12 V	100 V 100 V or less	M9BAV**	M9BA**	○	○	○	○	○	—		
							A96V	A96	Z76	●	—	●	—	—	IC circuit	—
							A93V	A93	Z73	●	—	●	—	—	—	Relay, PLC
							A90V	A90	Z80	●	—	●	—	—	—	IC circuit

** Water resistant type auto switches can be mounted on the above models, but in such case SMC cannot guarantee water resistance. Consult with SMC regarding water resistant types with the above model numbers.

* Lead wire length symbols: 0.5 m Nil (Example) M9NV
1 m M (Example) M9NVV
3 m L (Example) M9NVL
5 m Z (Example) M9NVZ

* Solid state auto switches marked with "C" are produced upon receipt of order.
* Separate switch spacers (BMG2-012) are required to retrofit auto switches (M9 type) on cylinders ø25 to ø63.

* There are other applicable auto switches than listed above. For details, refer to page 1321.

* For details about auto switches with pre-wired connector, refer to pages 1626 and 1627.

* Auto switches are shipped together (not assembled). (Refer to pages 1319 to 1321 for the details of auto switch mounting.)

Mechanically Jointed Rodless Cylinder Cam Follower Guide Type **Series MY1C**

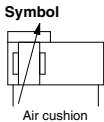
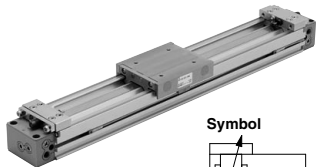

Made to Order; Individual Specifications
(For details, refer to page 1322.)

Symbol	Specifications
-X168	Helical insert thread specifications

Made to Order Specifications
(For details, refer to pages 1699 to 1818.)

Symbol	Specifications
-XB11	Long stroke
-XB22	Shock absorber soft type Series RJ type
-XC56	With knock pin hole
-XC67	NBR rubber lining in dust seal band

Specifications

Bore size (mm)	16	20	25	32	40	50	63
Fluid	Air						
Action	Double acting						
Operating pressure range	0.1 to 0.8 MPa						
Proof pressure	1.2 MPa						
Ambient and fluid temperature	5 to 60°C						
Cushion	Air cushion						
Lubrication	Non-lube						
Stroke length tolerance	1000 or less $^{+1.8}_0$ 1001 to 3000 $^{+2.8}_0$			2700 or less $^{+1.8}_0$, 2701 to 5000 $^{+2.8}_0$			
Piping port size	Front/Side port M5 x 0.8 ø4		Rc 1/8 ø6		Rc 1/4 ø8		Rc 3/8 ø10

Piston Speed

Bore size (mm)		16 to 63
Without stroke adjustment unit		100 to 1000 mm/s
Stroke adjustment unit	A unit	100 to 1000 mm/s ⁽¹⁾
	L unit and H unit	100 to 1500 mm/s ⁽²⁾

Note 1) Be aware that when the stroke adjustment range is increased by manipulating the adjustment bolt, the air cushion capacity decreases. Also, when exceeding the air cushion stroke ranges on page 1272, **the piston speed should be 100 to 200 mm per second.**

Note 2) The piston speed is 100 to 1000 mm/s for centralized piping.

Note 3) Use at a speed within the absorption capacity range. Refer to page 1272.

Stroke Adjustment Unit Specifications

Bore size (mm)		16			20			25			32			40			50			63		
Unit symbol		A	L	H	A	L	H	A	L	H	A	L	H	A	L	H	A	L	H			
Configuration Shock absorber model	Without spacer	RB 0806 + adjustment bolt	RB 0806 + adjustment bolt	RB 1007 + adjustment bolt	RB 1007 + adjustment bolt	RB 1412 + adjustment bolt	RB 1412 + adjustment bolt	RB 2015 + adjustment bolt	RB 2015 + adjustment bolt	RB 1412 + adjustment bolt	RB 2015 + adjustment bolt	RB 2015 + adjustment bolt	RB 1412 + adjustment bolt	RB 2015 + adjustment bolt	RB 2725 + adjustment bolt	RB 2725 + adjustment bolt	RB 1412 + adjustment bolt	RB 2015 + adjustment bolt	RB 2725 + adjustment bolt			
	With intermediate fixing spacer (mm)	-5.6 to -11.2	-6 to -12	-11.5 to -23	-12 to -24	-16 to -32	-20 to -40	-25 to -50														
	With long spacer	-11.2 to -16.8	-12 to -18	-23 to -34.5	-24 to -36	-32 to -48	-40 to -60	-50 to -75														

* Stroke adjustment range is applicable for one side when mounted on a cylinder.

Stroke Adjustment Unit Symbol

Left side stroke adjustment unit	Right side stroke adjustment unit	Right side stroke adjustment unit																		
		Without unit	A: With adjustment bolt						L: With low load shock absorber + Adjustment bolt						H: With high load shock absorber + Adjustment bolt					
			With short spacer	With long spacer	With short spacer	With long spacer	With short spacer	With long spacer	With short spacer	With long spacer										
Without unit	Nil	SA	SA6	SA7	SL	SL6	SL7	SH	SH6	SH7										
A: With adjustment bolt	AS	A	AA6	AA7	AL	AL6	AL7	AH	AH6	AH7										
With short spacer	A6S	A6A	A6	A6A7	A6L	A6L6	A6L7	A6H	A6H6	A6H7										
With long spacer	A7S	A7A	A7A6	A7	A7L	A7L6	A7L7	A7H	A7H6	A7H7										
L: With low load shock absorber + Adjustment bolt	LS	LA	LA6	LA7	L	LL6	LL7	LH	LH6	LH7										
With short spacer	L6S	L6A	L6A6	L6A7	L6L	L6L6	L6L7	L6H	L6H6	L6H7										
With long spacer	L7S	L7A	L7A6	L7A7	L7L	L7L6	L7L7	L7H	L7H6	L7H7										
H: With high load shock absorber + Adjustment bolt	HS	HA	HA6	HA7	HL	HL6	HL7	H	HH6	HH7										
With short spacer	H6S	H6A	H6A6	H6A7	H6L	H6L6	H6L7	H6H	H6H6	H6H7										
With long spacer	H7S	H7A	H7A6	H7A7	H7L	H7L6	H7L7	H7H	H7H6	H7H7										

* Spacers are used to fix the stroke adjustment unit at an intermediate stroke position.

Stroke adjustment unit mounting diagram

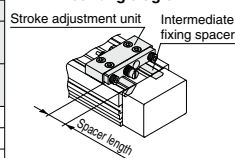

Example of H6H7 attachment

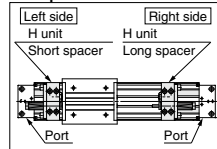

Shock Absorbers for L and H Units

Type	Stroke adjustment unit	Bore size (mm)						
		16	20	25	32	40	50	63
Standard (Shock absorber/RB series)	L	RB0806	RB1007	RB1412	RB2015	RB2725		
	H	—	RB1007	RB1412	RB2015	RB2725		
Shock absorber/soft type RJ series mounted (-XB22)	L	RJ0806H	RJ1007H	RJ1412H	—	—		
	H	—	RJ1007H	RJ1412H	—	—		

* The shock absorber service life is different from that of the MY1C cylinder depending on operating conditions. Refer to the RB Series Specific Product Precautions for the replacement period.

* Mounted shock absorber soft type RJ series (-XB22) is made to order specifications. For details, refer to page 1722.

Shock Absorber Specifications

Model		RB 0806	RB 1007	RB 1412	RB 2015	RB 2725
Max. energy absorption (J)		2.9	5.9	19.6	58.8	147
Stroke absorption (mm)		6	7	12	15	25
Max. collision speed (mm/s)		1500				
Max. operating frequency (cycle/min)		80	70	45	25	10
Spring force (N)	Extended	1.96	4.22	6.86	8.34	8.83
	Retracted	4.22	6.86	15.98	20.50	20.01
Operating temperature range (°C)		5 to 60				

* The shock absorber service life is different from that of the MY1C cylinder depending on operating conditions. Refer to the RB Series Specific Product Precautions for the replacement period.

Series MY1C

Theoretical Output

Bore size (mm)	Piston area (mm ²)	Operating pressure (MPa)						
		0.2	0.3	0.4	0.5	0.6	0.7	0.8
16	200	40	60	80	100	120	140	160
20	314	62	94	125	157	188	219	251
25	490	98	147	196	245	294	343	392
32	804	161	241	322	402	483	563	643
40	1256	251	377	502	628	754	879	1005
50	1962	392	588	784	981	1177	1373	1569
63	3115	623	934	1246	1557	1869	2180	2492

Note) Theoretical output (N) = Pressure (MPa) x Piston area (mm²)

Weight

Bore size (mm)	Basic weight	Additional weight per each 50 mm of stroke	Weight of moving parts	Side support bracket weight (per set) Type A and B	Stroke adjustment unit weight (per unit)		
					A unit weight	L unit weight	H unit weight
16	0.67	0.12	0.22	0.01	0.03	0.04	—
20	1.06	0.15	0.31	0.02	0.04	0.05	0.08
25	1.58	0.24	0.41	0.02	0.07	0.11	0.18
32	3.14	0.37	0.86	0.04	0.14	0.23	0.39
40	5.60	0.52	1.49	0.08	0.25	0.34	0.48
50	10.14	0.76	2.59	0.08	0.36	0.51	0.81
63	16.67	1.10	4.26	0.17	0.68	0.83	1.08

Calculation: (Example) MY1C25-300A

- Basic weight 1.58 kg
- Cylinder stroke 300 stroke
- Additional weight 0.24/50 stroke
- $1.58 + 0.24 \times 300/50 + 0.07 \times 2 \approx 3.16$ kg
- Weight of A unit 0.07 kg

Option

Stroke Adjustment Unit Part No.

MYM-A 25 L2-6N

Stroke adjustment unit

Intermediate fixing spacer

Spacer delivery style

Spacer length

Bore size	16 mm	20 mm	25 mm	32 mm	40 mm	50 mm	63 mm
16	16 mm						
20		20 mm					
25			25 mm				
32				32 mm			
40					40 mm		
50						50 mm	
63							63 mm

Symbol	Stroke adjustment unit	Mounting position
A1	A unit	Left
A2		Right
L1	L unit	Left
L2		Right
H1	H unit	Left
H2		Right

Unit no.	Without spacer	Short spacer	Long spacer
6	<input type="checkbox"/>	<input checked="" type="checkbox"/>	<input type="checkbox"/>
7	<input type="checkbox"/>	<input type="checkbox"/>	<input checked="" type="checkbox"/>

Spacer delivery style	Unit installed
NII	<input type="checkbox"/>
N	<input checked="" type="checkbox"/>

Note 1) Refer to page 1269 for details about adjustment range.

Note 2) A and L unit only for ø16

Component Parts

MYM-A25L2 (Without spacer)	MYM-A25L2-6 (With short spacer)	MYM-A25L2-7 (With long spacer)	MYM-A25L2-6N (Short spacer only)
			MYM-A25L2-7N (Long spacer only)

Side Support Part No.

Bore size (mm)	16	20	25	32	40	50	63
Side support A	MY-S16A	MY-S20A	MY-S25A	MY-S32A	MY-S40A	MY-S50A	MY-S63A
Side support B	MY-S16B	MY-S20B	MY-S25B	MY-S32B	MY-S40B	MY-S50B	MY-S63B

For details about dimensions, etc., refer to page 1281.

A set of side supports consists of a left support and a right support.

Cushion Capacity

Cushion Selection

<Air cushion>

Air cushions are a standard feature on mechanically jointed rodless cylinders. The air cushion mechanism is incorporated to prevent excessive impact of the piston at the stroke end during high speed operation. The purpose of air cushion, thus, is not to decelerate the piston near the stroke end.

The ranges of load and speed that air cushions can absorb are within the air cushion limit lines shown in the graphs.

<Stroke adjustment unit with shock absorber>

Use this unit when operating with a load or speed exceeding the air cushion limit line, or when cushioning is necessary because the cylinder stroke is outside of the effective air cushion stroke range due to stroke adjustment.

L unit

Use this unit when the cylinder stroke is outside of the effective air cushion range even if the load and speed are within the air cushion limit line, or when the cylinder is operated in a load and speed range above the air cushion limit line or below the L unit limit line.

H unit

Use this unit when the cylinder is operated in a load and speed range above the L unit limit line and below the H unit limit line.

⚠ Caution

1. Refer to the figure below when using the adjustment bolt to perform stroke adjustment.

When the effective stroke of the shock absorber decreases as a result of stroke adjustment, the absorption capacity decreases dramatically. Secure the adjustment bolt at the position where it protrudes approximately 0.5 mm from the shock absorber.

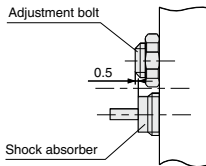

2. Do not use a shock absorber together with air cushion.

Air Cushion Stroke (mm)

Bore size (mm)	Cushion stroke
16	12
20	15
25	15
32	19
40	24
50	30
63	37

Absorption Capacity of Air Cushion and Stroke Adjustment Units

MY1C16

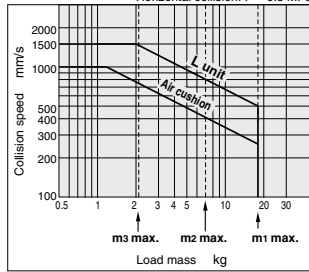

MY1C32

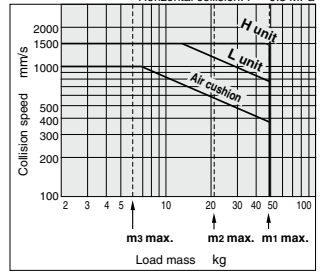

MY1C20

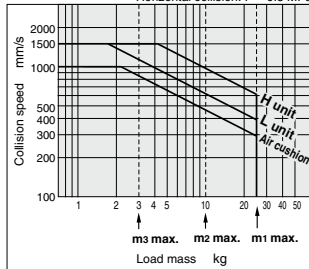

MY1C40

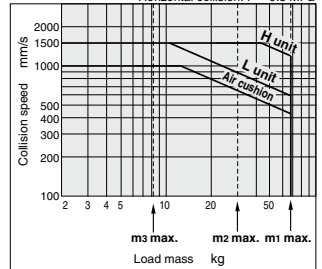

MY1C25

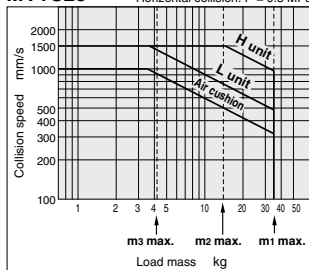

MY1C50

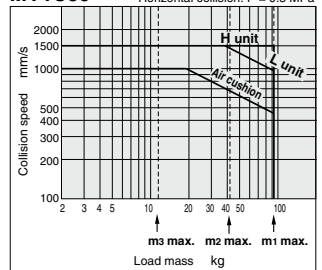

MY1C63

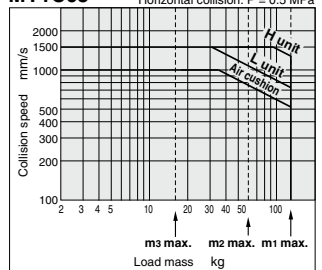



Tightening Torque for Stroke Adjustment Unit Holding Bolts (N·m)

Bore size (mm)	Unit	Tightening torque
16	A	0.7
	L	
20	A	1.8
	L	
	H	
25	A	3.5
	L	
	H	
32	A	5.8
	L	
	H	
40	A	13.8
	L	
	H	
50	A	13.8
	L	
	H	
63	A	27.5
	L	
	H	

Tightening Torque for Stroke Adjustment Unit Lock Plate Holding Bolts (N·m)

Bore size (mm)	Unit	Tightening torque
25	L	1.2
	H	3.3
32	L	3.3
	H	10
40	L	3.3
	H	10

Calculation of Absorbed Energy for Stroke Adjustment Unit with Shock Absorber (N·m)

Type of impact	Horizontal collision	Vertical (Downward)	Vertical (Upward)
			
Kinetic energy E_1	$\frac{1}{2} m \cdot v^2$		
Thrust energy E_2	$F \cdot s$	$F \cdot s + m \cdot g \cdot s$	$F \cdot s - m \cdot g \cdot s$
Absorbed energy E	$E_1 + E_2$		

Symbol
 v: Speed of impact object (m/s)
 F: Cylinder thrust (N)
 s: Shock absorber stroke (m)
 m: Mass of impact object (kg)
 g: Gravitational acceleration (9.8 m/s²)

Note) The speed of the impact object is measured at the time of impact with the shock absorber.

⚠ Precautions

Be sure to read before handling. Refer to front matter 57 for Safety Instructions and pages 3 to 12 for Actuator and Auto Switch Precautions.

⚠ Caution

Use caution not to get your hands caught in the unit.

- When using a product with stroke adjustment unit, the space between the slide table (slider) and the stroke adjusting unit becomes narrow at the stroke end, causing a danger of hands getting caught. Install a protective cover to prevent direct contact with the human body.

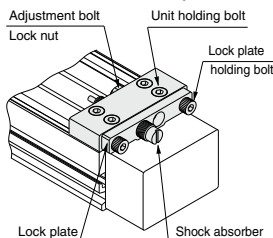

<Fastening of unit>
 The unit can be secured by evenly tightening the four unit holding bolts.

⚠ Caution

Do not operate with the stroke adjustment unit fixed in an intermediate position.

When the stroke adjusting unit is fixed in an intermediate position, slippage can occur depending on the amount of energy released at the time of an impact. In such cases, as a stroke adjustment unit with the spacer for intermediate securing is available, it is recommended to use it.

For other lengths, please consult with SMC (Refer to "Tightening Torque for Stroke Adjustment Unit Holding Bolts".)

<Stroke adjustment with adjusting bolt>

Loosen the adjusting bolt lock nut, and adjust the stroke from the lock plate side using a hexagon wrench. Retighten the lock nut.

<Stroke adjustment with shock absorber>

Loosen the two lock plate holding bolts, turn the shock absorber and adjust the stroke. Then, uniformly tighten the lock plate holding bolts to secure the shock absorber.

Take care not to over-tighten the holding bolts. (Except $\phi 16$, $\phi 20$, $\phi 50$, $\phi 63$) (Refer to "Tightening Torque for Stroke Adjusting Unit Lock Plate Holding Bolts".)

Note) Although the lock plate may slightly bend due to tightening of the lock plate holding bolt, this does not affect the shock absorber and locking function.

MY1B

-Z

MY1H

-Z

MY1B

MY1M

MY1C

MY1H

MY1

HT

MY1

□W

MY2C

MY2

□H

MY3A

MY3B

MY3M

MY3M

MY3M

MY3M

MY3M

MY3M

MY3M

MY3M

MY3M

MY3M

MY3M

MY3M

MY3M

MY3M

MY3M

MY3M

MY3M

MY3M

MY3M

MY3M

MY3M

MY3M

MY3M

MY3M

MY3M

MY3M

MY3M

MY3M

MY3M

MY3M

MY3M

MY3M

MY3M

MY3M

MY3M

MY3M

Series MY1C

Construction: $\varnothing 16$ to $\varnothing 63$

MY1C16 to 63

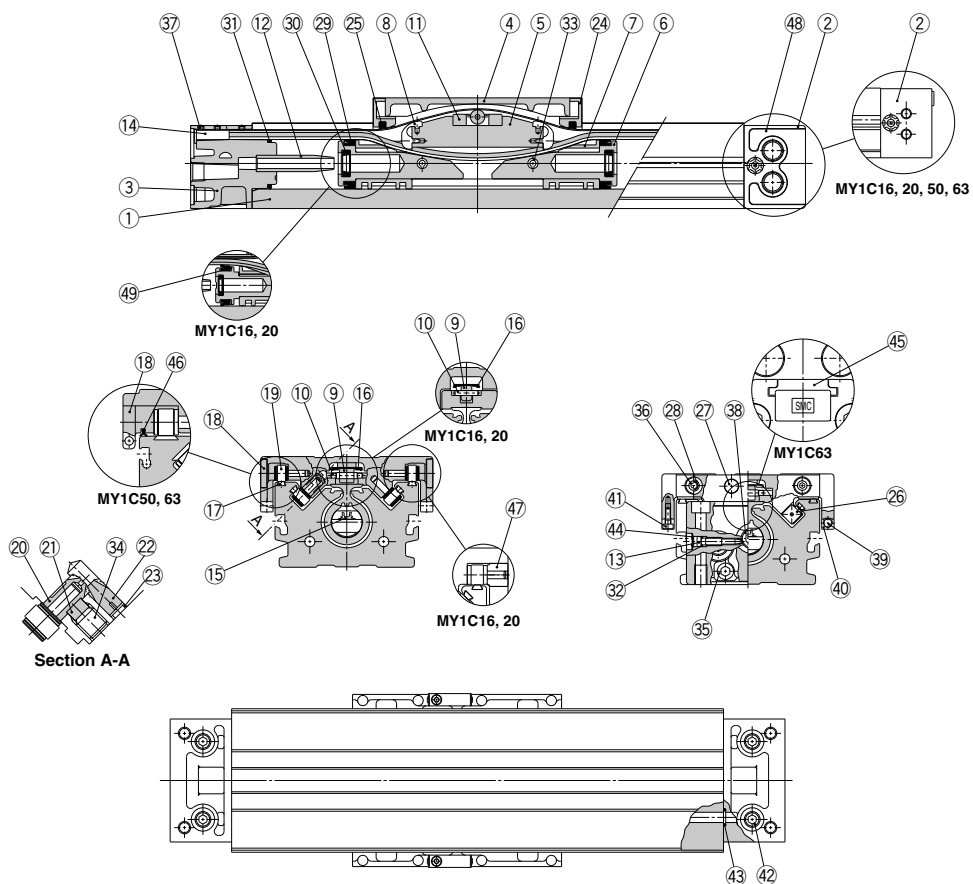

MY1C16 to 63

Component Parts

No.	Description	Material	Note
1	Cylinder tube	Aluminum alloy	Hard anodized
2	Head cover WR	Aluminum alloy	Painted
3	Head cover WL	Aluminum alloy	Painted
4	Slide table	Aluminum alloy	Electroless nickel plated
5	Piston yoke	Aluminum alloy	Chromated
6	Piston	Aluminum alloy	Chromated
7	Wear ring	Special resin	
8	Belt separator	Special resin	
9	Guide roller	Special resin	
10	Guide roller shaft	Stainless steel	
11	Coupler	Sintered iron material	
12	Cushion ring	Aluminum alloy	Anodized
13	Cushion needle	Rollled steel	Nickel plated
14	Belt clamp	Special resin	
17	Rail	Hard steel wire	
18	Cam follower cap	Special resin	(ø25 to ø40)
19	Cam follower	—	
20	Eccentric gear	Stainless steel	
21	Gear bracket	Stainless steel	
22	Adjustment gear	Stainless steel	
23	Retaining ring	Stainless steel	

No.	Description	Material	Note
24	End Cover	Special resin	
26	Backup plate	Special resin	
27	Stopper	Carbon steel	Nickel plated
28	Spacer	Stainless steel	
33	Spring pin	Carbon tool steel	
34	Hexagon socket head set screw	Chromium molybdenum steel	Black zinc chromated
35	Hexagon socket head cap screw	Chromium molybdenum steel	Nickel plated
36	Hexagon socket button head screw	Chromium molybdenum steel	Nickel plated
37	Hexagon socket head set screw	Chromium molybdenum steel	Black zinc chromated/Nickel plated
38	Hexagon socket head taper plug	Carbon steel	Nickel plated
39	Magnet		
40	Magnet holder	Special resin	
41	Hexagon socket head cap screw	Chromium molybdenum steel	Nickel plated
42	Hexagon socket head taper plug	Carbon steel	Nickel plated
44	Type CR retaining ring	Spring steel	
45	Head plate	Aluminum alloy	Hard anodized (ø63)
46	Side scraper	Special resin	(ø50 to ø63)
47	Bushing	Aluminum alloy	(ø16 to ø20)
48	Port cover	Special resin	(ø25 to ø40)
49	Lube retainer	Special resin	(ø16 to ø20)

Replacement Part: Seal Kit

No.	Description	Qty.	MY1C16	MY1C20	MY1C25	MY1C32	MY1C40	MY1C50	MY1C63
15	Seal belt	1	MY16-16A-Stroke	MY20-16A-Stroke	MY25-16A-Stroke	MY32-16A-Stroke	MY40-16A-Stroke	MY50-16A-Stroke	MY63-16A-Stroke
16	Dust seal band	1	MY16-16B-Stroke	MY20-16B-Stroke	MY25-16B-Stroke	MY32-16B-Stroke	MY40-16B-Stroke	MY50-16B-Stroke	MY63-16B-Stroke
32	O-ring	2	KA00309 (ø4 x ø1.8 x ø1.1)	KA00311 (ø5.1 x ø3 x ø1.05)	KA00311 (ø5.1 x ø3 x ø1.05)	KA00320 (ø7.15 x ø3.75 x ø1.7)	KA00402 (ø8.3 x ø4.5 x ø1.9)	—	—
46	Side scraper	2	—	—	—	—	—	MYM50-15CK0502B	MYM63-15CK0503B
25	Scraper	2							
29	Piston seal	2							
30	Cushion seal	2	MY1M16-PS	MY1M20-PS	MY1M25-PS	MY1M32-PS	MY1M40-PS	MY1M50-PS	MY1M63-PS
31	Tube gasket	2							
43	O-ring	4							

* Seal kit includes (25), (29), (30), (31) and (43). Order the seal kit based on each bore size.

* Seal kit includes a grease pack (10 g).

When (15) and (16) are shipped independently, a grease pack is included. (10 g per 1000 strokes)

Order with the following part number when only the grease pack is needed.

Grease pack part number: GR-S-010 (10 g), GR-S-020 (20 g)

Note) Two kinds of dust seal bands are available. Verify the type to use, since the part number varies depending on the treatment of the hexagon socket head set screw (37).

A: Black zinc chromated → MY□□-16B-stroke, B: Nickel plated → MY□□-16BW-stroke

MY1B

-Z

MY1H

-Z

MY1B

MY1M

MY1C

MY1H

MY1

HT

MY1

□W

MY2C

MY2

H□

MY3A

MY3B

MY3M

MY2C

MY2

H□

MY3A

MY3B

MY3M

MY3M

MY3M

MY3M

MY3M

MY3M

MY3M

MY3M

MY3M

MY3M

MY3M

MY3M

MY3M

MY3M

MY3M

MY3M

MY3M

MY3M

MY3M

MY3M

MY3M

MY3M

MY3M

MY3M

MY3M

MY3M

MY3M

MY3M

MY3M

MY3M

Series MY1C

Standard Type/Centralized Piping Type $\phi 16, \phi 20$

Refer to page 1325 regarding centralized piping port variations.

MY1C16□/20□ — Stroke

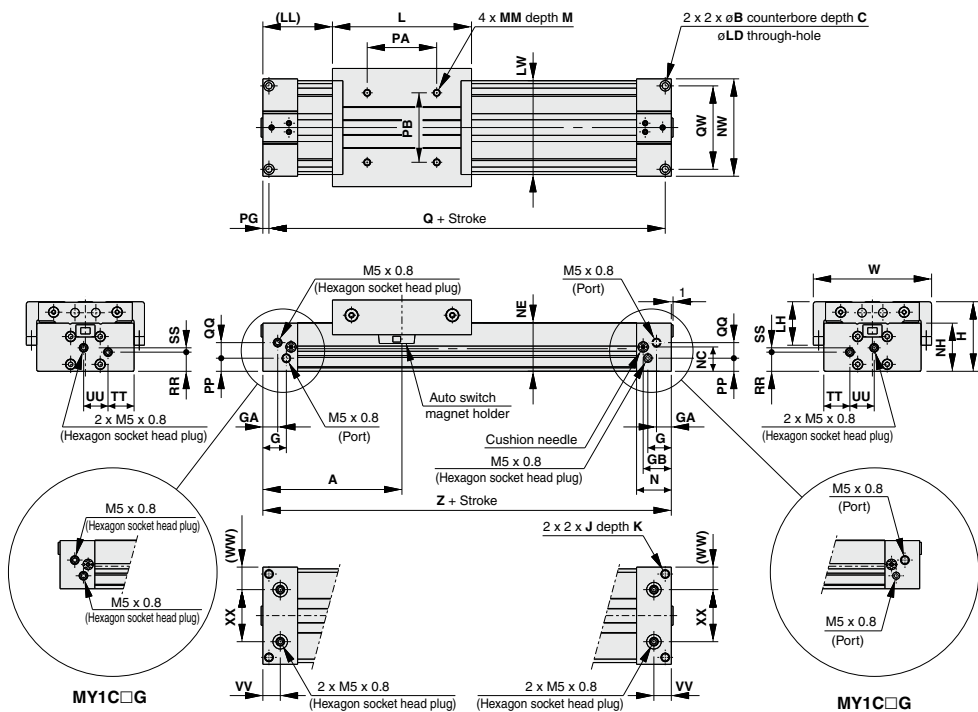

Model	A	B	C	G	GA	GB	H	J	K	L	LD	LH	LL	LW	M	MM	N	NC
MY1C16□	80	6	3.5	13.5	8.5	16.2	40	M5 x 0.8	10	80	3.6	22.5	40	54	6	M4 x 0.7	20	14
MY1C20□	100	7.5	4.5	12.5	12.5	20	46	M6 x 1	12	100	4.8	23	50	58	7.5	M5 x 0.8	25	17

Model	NE	NH	NW	PA	PB	PG	PP	Q	QQ	QW	RR	SS	TT	UU	VV	W	WW	XX	Z
MY1C16□	28	27.7	56	40	40	3.5	7.5	153	9	48	11	2.5	15	14	10	68	13	30	160
MY1C20□	34	33.7	60	50	40	4.5	11.5	191	10	45	14.5	5	18	12	12.5	72	14	32	200

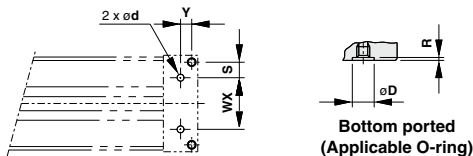

Hole Sizes for Centralized Piping on the Bottom

Model	WX	Y	S	d	D	R	Applicable O-ring
MY1C16□	30	6.5	9	4	8.4	1.1	C6
MY1C20□	32	8	6.5	4	8.4	1.1	

(Machine the mounting side to the dimensions below.)

Mechanically Jointed Rodless Cylinder Cam Follower Guide Type *Series MY1C*

Standard Type/Centralized Piping Type $\varnothing 25, \varnothing 32, \varnothing 40$ Refer to page 1325 regarding centralized piping port variations.

MY1C25□/32□/40□ — Stroke

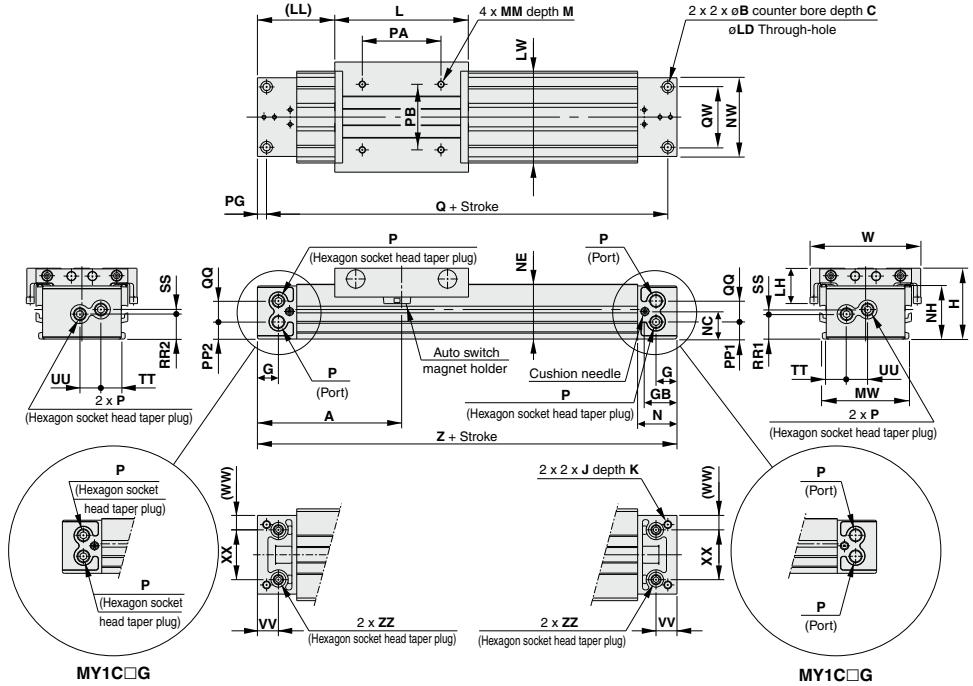

MY1C□G

MY1C□G

Model	A	B	C	G	GB	H	J	K	L	LD	LH	LL	LW	M	MM	MW	N	NC	NE	NH	NW	P	PA
MY1C25□	110	9	5.5	17	24.5	54	M6 x 1	9.5	102	5.6	27	59	70	10	M5 x 0.8	66	30	21	41.8	40.5	60	Rc 1/8	60
MY1C32□	140	11	6.5	19	30	68	M8 x 1.25	16	132	6.8	35	74	88	13	M6 x 1	80	37	26	52.3	50	74	Rc 1/8	80
MY1C40□	170	14	8.5	23	36.5	84	M10 x 1.5	15	162	8.6	38	89	104	13	M6 x 1	96	45	32	65.3	63.5	94	Rc 1/4	100

(mm)

P indicates cylinder supply ports.

Model	PB	PG	PP1	PP2	Q	QQ	QW	RR1	RR2	SS	TT	UU	VV	W	WW	XX	Z	ZZ
MY1C25□	50	7	12.7	12.7	206	15.5	46	18.9	17.9	4.1	15.5	16	16	84	11	38	220	Rc 1/16
MY1C32□	60	8	15.5	18.5	264	16	60	22	24	4	21	16	19	102	13	48	280	Rc 1/16
MY1C40□	80	9	17.5	20	322	26	72	25.5	29	9	26	21	23	118	20	54	340	Rc 1/8

(mm)

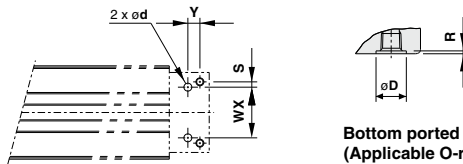

**Bottom ported (ZZ)
(Applicable O-ring)**

Hole Size for Centralized Piping on the Bottom

Model	WX	Y	S	d	D	R	Applicable O-ring
MY1C25□	38	9	4	6	11.4	1.1	C9
MY1C32□	48	11	6	6	11.4	1.1	
MY1C40□	54	14	9	8	13.4	1.1	C11.2

(Machine the mounting side to the dimensions below.)

MY1B
-Z

MY1H
-Z

MY1B

MY1M

MY1C

MY1H

MY1
HT

MY1
□W

MY2C

MY2
H□

MY3A
MY3B

MY3M

D-□

-X□

Technical
data

Series MY1C

Standard Type/Centralized Piping Type $\phi 50, \phi 63$

Refer to page 1325 regarding centralized piping port variations.

MY1C50□/63□ — Stroke

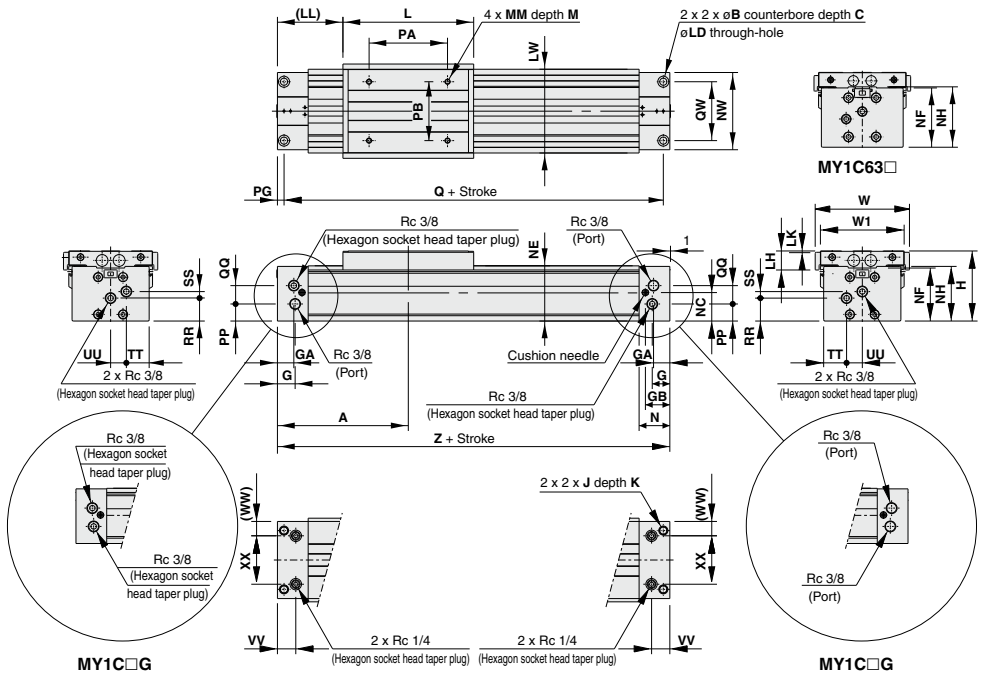

Model	A	B	C	G	GA	GB	H	J	K	L	LD	LH	LK	LL	LW	M	MM	N	NC	NE
MY1C50□	200	17	10.5	27	25	37.5	107	M14 x 2	28	200	11	29	2	100	128	15	M8 x 1.25	47	43.5	84.5
MY1C63□	230	19	12.5	29.5	27.5	39.5	130	M16 x 2	32	230	13.5	32.5	5.5	115	152	16	M10 x 1.5	50	60	104

Model	NF	NH	NW	PA	PB	PG	PP	Q	QQ	QW	RR	SS	TT	UU	VV	W	W1	WW	XX	Z
MY1C50□	81	83.5	118	120	90	10	26	380	28	90	35	10	35	24	28	144	128	22	74	400
MY1C63□	103	105	142	140	110	12	42	436	30	110	49	13	43	28	30	168	152	25	92	460

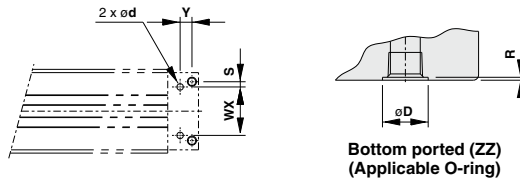

**Bottom ported (ZZ)
(Applicable O-ring)**

Hole Size for Centralized Piping on the Bottom

Model	WX	Y	S	d	D	R	Applicable O-ring
MY1C50□	74	18	8	10	17.5	1.1	C15
MY1C63□	92	18	9	10	17.5	1.1	

(Machine the mounting side to the dimensions above.)

Stroke Adjustment Unit

With adjustment bolt

MY1C Bore size — Stroke A

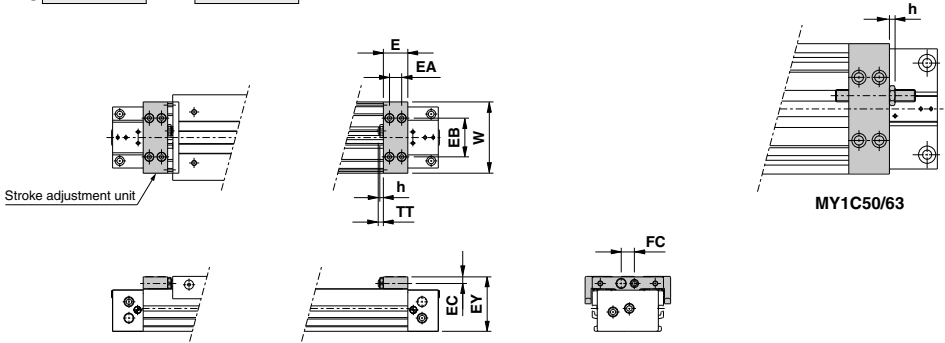

MY1C50/63

Applicable bore size	E	EA	EB	EC	EY	FC	h	TT	W
MY1C16	14.6	7	30	5.8	39.5	14	3.6	5.4 (Max. 11)	58
MY1C20	20	10	32	5.8	45.5	14	3.6	5 (Max. 11)	58
MY1C25	24	12	38	6.5	53.5	13	3.5	5 (Max. 16.5)	70
MY1C32	29	14	50	8.5	67	17	4.5	8 (Max. 20)	88
MY1C40	35	17	57	10	83	17	4.5	9 (Max. 25)	104
MY1C50	40	20	66	14	106	26	5.5	13 (Max. 33)	128
MY1C63	52	26	77	14	129	31	5.5	13 (Max. 38)	152

With low load shock absorber + Adjustment bolt

MY1C Bore size — Stroke L

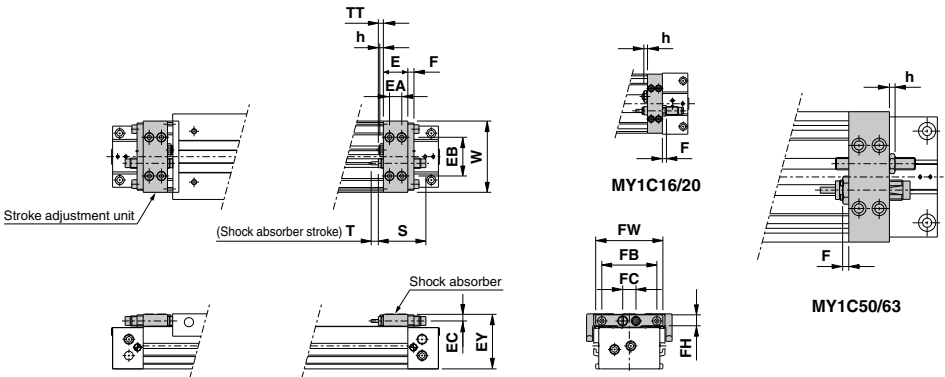

MY1C16/20

MY1C50/63

Applicable bore size	E	EA	EB	EC	EY	F	FB	FC	FH	FW	h	S	T	TT	W	Shock absorber model
MY1C16	14.6	7	30	5.8	39.5	4	—	14	—	—	3.6	40.8	6	5.4 (Max. 11)	58	RB0806
MY1C20	20	10	32	5.8	45.5	4	—	14	—	—	3.6	40.8	6	5 (Max. 11)	58	RB0806
MY1C25	24	12	38	6.5	53.5	6	54	13	13	66	3.5	46.7	7	5 (Max. 16.5)	70	RB1007
MY1C32	29	14	50	8.5	67	6	67	17	16	80	4.5	67.3	12	8 (Max. 20)	88	RB1412
MY1C40	35	17	57	10	83	6	78	17	17.5	91	4.5	67.3	12	9 (Max. 25)	104	RB1412
MY1C50	40	20	66	14	106	6	—	26	—	—	5.5	73.2	15	13 (Max. 33)	128	RB2015
MY1C63	52	26	77	14	129	6	—	31	—	—	5.5	73.2	15	13 (Max. 38)	152	RB2015

(mm)

MY1B

Z

MY1H

Z

MY1B

MY1M

MY1C

MY1H

MY1

HT

MY1

W

MY2C

MY2

H

MY3A

MY3B

MY3M

D-

-X

Technical data

Series MY1C

Stroke Adjustment Unit

With high load shock absorber + Adjustment bolt

MY1C Bore size — Stroke H

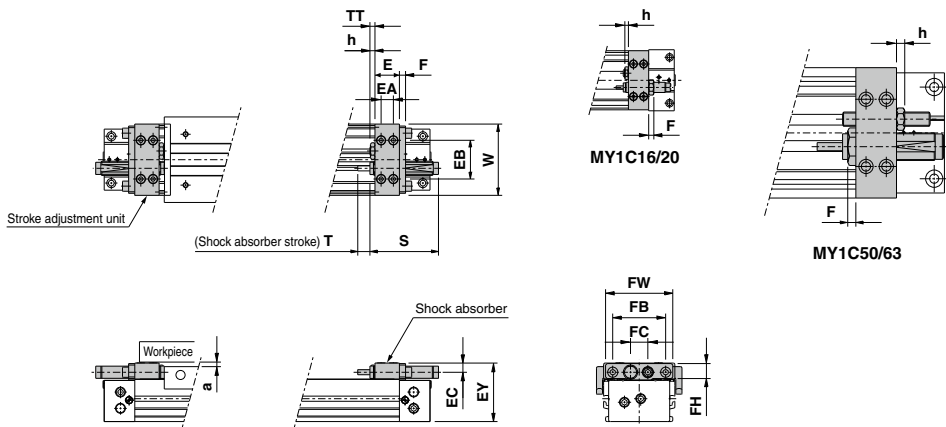

* Since dimension EY of the H type unit is greater than the table top height (dimension H), when mounting a workpiece that exceeds the overall length (dimension L) of the slide table, allow a clearance of dimension "a" or larger on the workpiece side.

Applicable bore size	E	EA	EB	EC	EY	F	FB	FC	FH	FW	h	S	T	TT	W	Shock absorber model	a
MY1C20	20	10	32	7.7	50	5	—	14	—	—	3.5	46.7	7	5 (Max. 11)	58	RB1007	5
MY1C25	24	12	38	9	57.5	6	52	17	16	66	4.5	67.3	12	5 (Max. 16.5)	70	RB1412	4.5
MY1C32	29	14	50	11.5	73	8	67	22	22	82	5.5	73.2	15	8 (Max. 20)	88	RB2015	6
MY1C40	35	17	57	12	87	8	78	22	22	95	5.5	73.2	15	9 (Max. 25)	104	RB2015	4
MY1C50	40	20	66	18.5	115	8	—	30	—	—	11	99	25	13 (Max. 33)	128	RB2725	9
MY1C63	52	26	77	19	138.5	8	—	35	—	—	11	99	25	13 (Max. 38)	152	RB2725	9.5

Side Support

Side support A MY-S□A

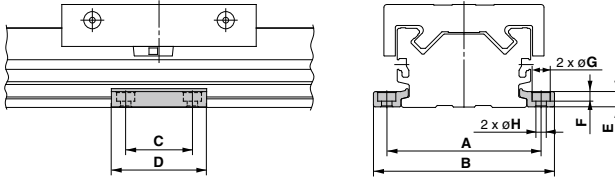

Side support B MY-S□B

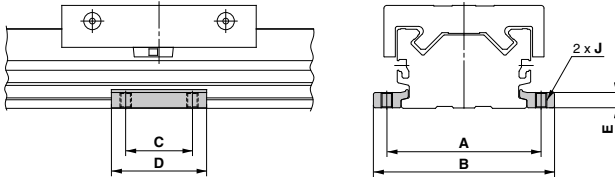

(mm)

Model	Applicable bore size	A	B	C	D	E	F	G	H	J
MY-S16 [△]	MY1C16	61	71.6	15	26	4.9	3	6.5	3.4	M4 x 0.7
MY-S20 [△]	MY1C20	67	79.6	25	38	6.4	4	8	4.5	M5 x 0.8
MY-S25 [△]	MY1C25	81	95	35	50	8	5	9.5	5.5	M6 x 1
MY-S32 [△]	MY1C32	100	118	45	64	11.7	6	11	6.6	M8 x 1.25
MY-S40 [△]	MY1C40	120	142	55	80	14.8	8.5	14	9	M10 x 1.5
	MY1C50	142	164							
MY-S63 [△]	MY1C63	172	202	70	100	18.3	10.5	17.5	11.5	M12 x 1.75

* A set of side supports consists of a left support and a right support.

Guide for Side Support Application

For long stroke operation, the cylinder tube may be deflected depending on its own weight and the load weight. In such a case, use a side support in the middle section. The spacing (L) of the support must be no more than the values shown in the graph on the right.

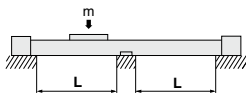
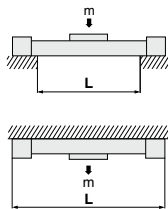

Caution

1. If the cylinder mounting surfaces are not measured accurately, using a side support may cause poor operation. Therefore, be sure to level the cylinder tube when mounting. Also, for long stroke operation involving vibration and impact, use of a side support is recommended even if the spacing value is within the allowable limits shown in the graph.

2. Support brackets are not for mounting; use them solely for providing support.

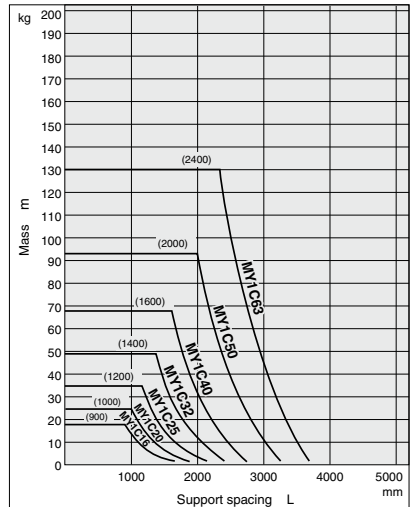

MY1B

-Z

MY1H

-Z

MY1B

MY1M

MY1C

MY1H

-Z

MY1

HT

MY1

□W

MY2C

MY2

□H

MY3A

MY3B

MY3M

MY3M

MY3M

MY3M

MY3M

MY3M

MY3M

MY3M

MY3M

MY3M

MY3M

MY3M

MY3M

MY3M

MY3M

MY3M

MY3M

MY3M

MY3M

MY3M

MY3M

MY3M

MY3M

MY3M

MY3M

MY3M

MY3M

MY3M

Series MY1H

Linear Guide Type

ø10, ø16, ø20, ø25, ø32, ø40

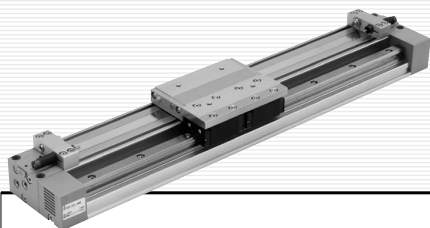

Uses a linear guide to achieve high repeatability

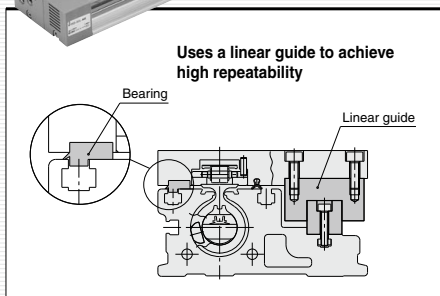

End lock type capable of holding a position at the stroke end
(Except bore size ø10)

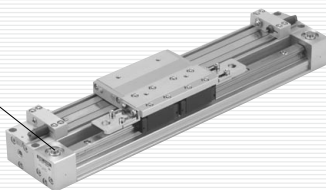

MY1B
-Z

MY1H
-Z

MY1B

MY1M

MY1C

MY1H

MY1
HT

MY1
□W

MY2C

MY2
H□

MY3A
MY3B

MY3M

D-□

-X□

Technical
data

Maximum Allowable Moment/Maximum Load Mass

Model	Bore size (mm)	Maximum allowable moment (N·m)			Maximum load mass (kg)		
		M1	M2	M3	m1	m2	m3
MY1H	10	0.8	1.1	0.8	6.1	6.1	6.1
	16	3.7	4.9	3.7	10.8	10.8	10.8
	20	11	16	11	17.6	17.6	17.6
	25	23	26	23	27.5	27.5	27.5
	32	39	50	39	39.2	39.2	39.2
	40	50	50	39	50	50	

The above values are the maximum allowable values for moment and load. Refer to each graph regarding the maximum allowable moment and maximum allowable load for a particular piston speed.

Load mass (kg)

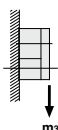
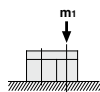

Moment (N·m)

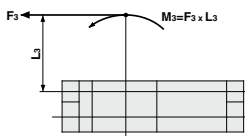
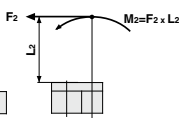
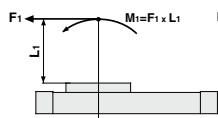

<Calculation of guide load factor>

- Maximum allowable load (1), static moment (2), and dynamic moment (3) (at the time of impact with stopper) must be examined for the selection calculations.
 * To evaluate, use \bar{v}_a (average speed) for (1) and (2), and v (collision speed $v = 1.4v_a$) for (3). Calculate m_{max} for (1) from the maximum allowable load graph (m_1, m_2, m_3) and M_{max} for (2) and (3) from the maximum allowable moment graph (M_1, M_2, M_3).

$$\text{Sum of guide load factors } \Sigma \alpha = \frac{\text{Load mass [m]}}{\text{Maximum allowable load [m max]}} + \frac{\text{Static moment [M] }^{(1)}}{\text{Allowable static moment [Mmax]}} + \frac{\text{Dynamic moment [ME] }^{(2)}}{\text{Allowable dynamic moment [MEmax]}} \leq 1$$

- Note 1) Moment caused by the load, etc., with cylinder in resting condition.
 Note 2) Moment caused by the impact load equivalent at the stroke end (at the time of impact with stopper).
 Note 3) Depending on the shape of the workpiece, multiple moments may occur. When this happens, the sum of the load factors ($\Sigma \alpha$) is the total of all such moments.

2. Reference formula [Dynamic moment at impact]

Use the following formulae to calculate dynamic moment when taking stopper impact into consideration.

- m**: Load mass (kg)
- F**: Load (N)
- Fe**: Load equivalent to impact (at impact with stopper) (N)
- \bar{v}_a** : Average speed (mm/s)
- M**: Static moment (N·m)
- v**: Collision speed (mm/s)
- L**: Distance to the load's center of gravity (m)
- ME**: Dynamic moment (N·m)
- δ** : Damper coefficient
 With rubber bumper = 4/100 (MY1B10, MY1H10)
 With air cushion = 1/100
 With shock absorber = 1/100
- g**: Gravitational acceleration (9.8 m/s²)

$$v = 1.4\bar{v}_a \quad \text{Fe} = 1.4\bar{v}_a \cdot \delta \cdot m \cdot g$$

$$\therefore ME = \frac{1}{3} \cdot Fe \cdot L = 4.57\bar{v}_a \delta m L \quad (\text{Note 4})$$

Note 4) $1.4\bar{v}_a \delta$ is a dimensionless coefficient for calculating impact force.

Note 5) Average load coefficient ($= \frac{1}{3}$): This coefficient is for averaging the maximum load moment at the time of stopper impact according to service life calculations.

- For detailed selection procedures, refer to pages 1286 and 1287.

Maximum Allowable Moment

Select the moment from within the range of operating limits shown in the graphs. Note that the maximum allowable load value may sometimes be exceeded even within the operating limits shown in the graphs. Therefore, also check the allowable load for the selected conditions.

Maximum Load Mass

Select the load from within the range of limits shown in the graphs. Note that the maximum allowable moment value may sometimes be exceeded even within the operating limits shown in the graphs. Therefore, also check the allowable moment for the selected conditions.

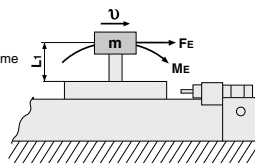

MY1H/M₁

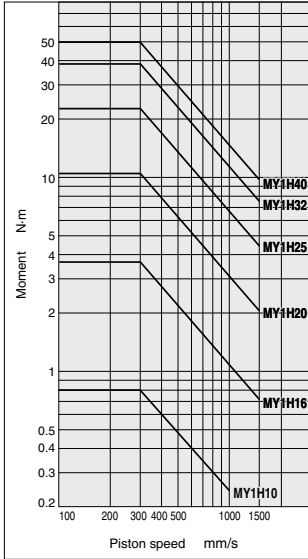

MY1H/M₂

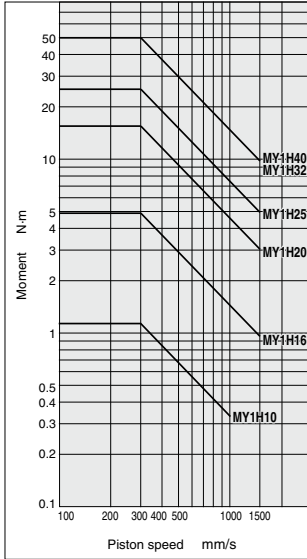

MY1H/M₃

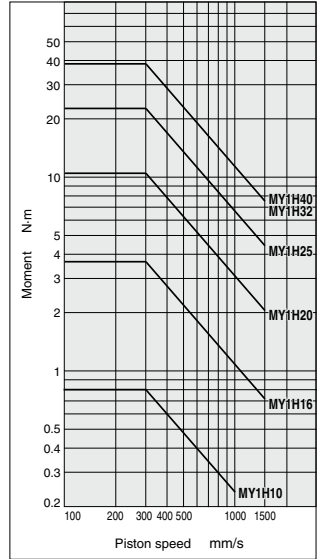

MY1H/m₁

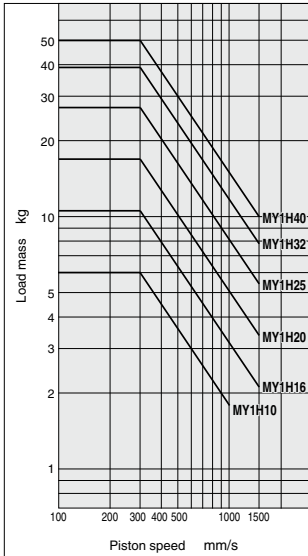

MY1H/m₂

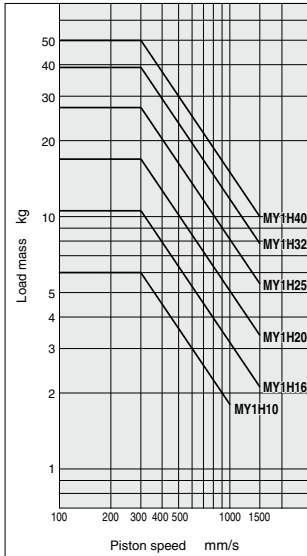

MY1H/m₃

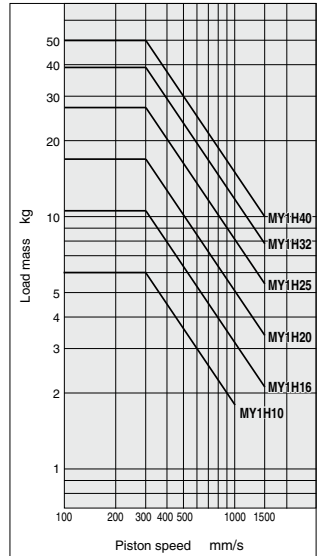

MY1B
-Z

MY1H
-Z

MY1B

MY1M

MY1C

MY1H

MY1
HT

MY1
W

MY2C

MY2
H

MY3A

MY3B

MY3M

D-

-X

Technical
data

Series MY1H Model Selection

Following are the steps for selecting the most suitable Series MY1H to your application.

Calculation of Guide Load Factor

1. Operating Conditions

Operating cylinder MY1H40-500
 Average operating speed v_a ... 300 mm/s
 Mounting orientation Wall mounting
 Cushion Air cushion ($\delta = 1/100$)

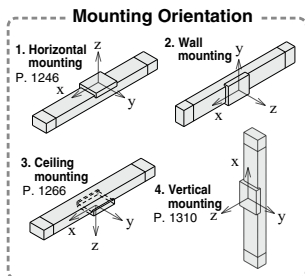
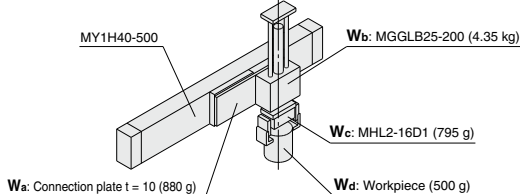

For actual examples of calculation for each orientation, refer to the pages above.

2. Load Blocking

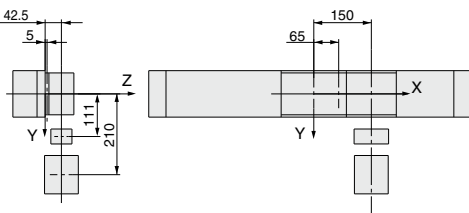

Mass and Center of Gravity for Each Workpiece

Workpiece no.	Mass m_n	Center of gravity		
		X-axis X_n	Y-axis Y_n	Z-axis Z_n
Wa	0.88 kg	65 mm	0 mm	5 mm
Wb	4.35 kg	150 mm	0 mm	42.5 mm
Wc	0.795 kg	150 mm	111 mm	42.5 mm
Wd	0.5 kg	150 mm	210 mm	42.5 mm

n=a, b, c, d

3. Composite Center of Gravity Calculation

$$m_3 = \sum m_n$$

$$= 0.88 + 4.35 + 0.795 + 0.5 = 6.525 \text{ kg}$$

$$X = \frac{1}{m_3} \times \sum (m_n \times X_n)$$

$$= \frac{1}{6.525} (0.88 \times 65 + 4.35 \times 150 + 0.795 \times 150 + 0.5 \times 150) = 138.5 \text{ mm}$$

$$Y = \frac{1}{m_3} \times \sum (m_n \times Y_n)$$

$$= \frac{1}{6.525} (0.88 \times 0 + 4.35 \times 0 + 0.795 \times 111 + 0.5 \times 210) = 29.6 \text{ mm}$$

$$Z = \frac{1}{m_3} \times \sum (m_n \times Z_n)$$

$$= \frac{1}{6.525} (0.88 \times 5 + 4.35 \times 42.5 + 0.795 \times 42.5 + 0.5 \times 42.5) = 37.4 \text{ mm}$$

4. Calculation of Load Factor for Static Load

m_3 : Mass

$m_3 \text{ max}$ (from (1) of graph MY1H/ m_3) = 50 (kg).....

Load factor $\alpha_1 = m_3/m_3 \text{ max} = 6.525/50 = 0.13$

M_2 : Moment

$m_2 \text{ max}$ (from (2) of graph MY1H/ M_2) = 50 (N·m).....

$M_2 = m_3 \times g \times Z = 6.525 \times 9.8 \times 37.4 \times 10^{-3} = 2.39 \text{ (N·m)}$

Load factor $\alpha_2 = M_2/M_2 \text{ max} = 2.39/50 = 0.05$

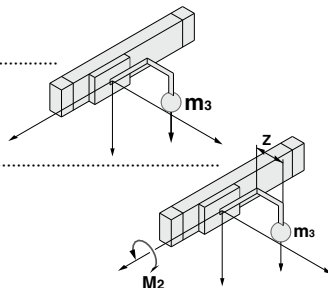

M₃: Moment

M₃ max (from (3) of graph MY1H/M₃) = 38.7 (N·m).....

M₃ = m₃ × g × X = 6.525 × 9.8 × 138.5 × 10⁻³ = 8.86 (N·m)

Load factor **α₃ = M₃/M₃ max = 8.86/38.7 = 0.23**

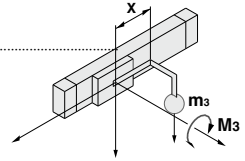

5. Calculation of Load Factor for Dynamic Moment

Equivalent load F_E at impact

F_E = 1.4U_a × δ × m × g = 1.4 × 300 × $\frac{1}{100}$ × 6.525 × 9.8 = 268.6 (N)

M_{1E}: Moment

M_{1E} max (from (4) of graph MY1H/M₁ where 1.4U_a = 420 mm/s) = 35.9 (N·m).....

M_{1E} = $\frac{1}{3}$ × F_E × Z = $\frac{1}{3}$ × 268.6 × 37.4 × 10⁻³ = 3.35 (N·m)

Load factor **α₄ = M_{1E}/M_{1E} max = 3.35/35.9 = 0.09**

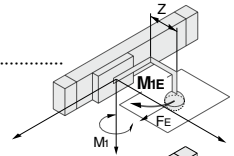

M_{3E}: Moment

M_{3E} max (from (5) of graph MY1H/M₃ where 1.4U_a = 420 mm/s) = 27.6 (N·m).....

M_{3E} = $\frac{1}{3}$ × F_E × Y = $\frac{1}{3}$ × 268.6 × 29.6 × 10⁻³ = 2.65 (N·m)

Load factor **α₅ = M_{3E}/M_{3E} max = 2.65/27.6 = 0.10**

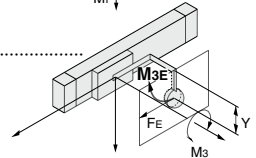

6. Sum and Examination of Guide Load Factors

Σα = α₁ + α₂ + α₃ + α₄ + α₅ = 0.60 ≤ 1

The above calculation is within the allowable value, and therefore the selected model can be used.

Select a shock absorber separately.

In an actual calculation, when the total sum of guide load factors Σα in the formula above is more than 1, consider either decreasing the speed, increasing the bore size, or changing the product series.

This calculation can be easily made using the "SMC Pneumatics CAD System".

MY1B

-Z

MY1H

-Z

MY1B

MY1M

MY1C

MY1H

MY1

HT

MY1

□W

MY2C

MY2

□H

MY3A

MY3B

MY3M

Load Mass

MY1H/m₃

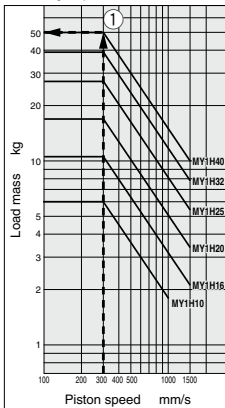

Allowable Moment

MY1H/M₁

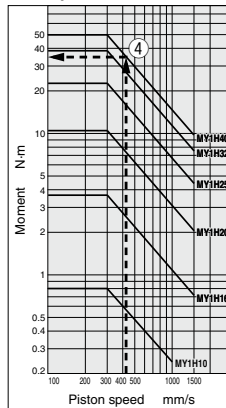

MY1H/M₂

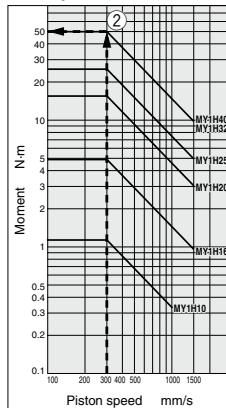

MY1H/M₃

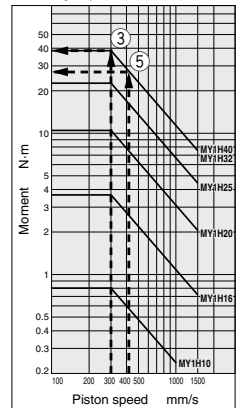

D-□

-X□

Technical data

Mechanically Jointed Rodless Cylinder Linear Guide Type

Series MY1H

ø10, ø16, ø20, ø25, ø32, ø40

Series MY1H linear guide type ø25, ø32, and ø40 sizes have been remodeled with improved piping flexibility. Refer to **page1187** for details.

How to Order

Linear guide type **MY1H** **25** **300** **M9BW**

Linear guide type

Bore size

10	10 mm
16	16 mm
20	20 mm
25	25 mm
32	32 mm
40	40 mm

Port thread type

Symbol	Type	Bore size
Nil	M thread	ø10, ø16, ø20
	Rc	
TN	NPT	ø25, ø32, ø40
TF	G	

Piping

Nil	Standard type
G	Centralized piping type

Note) For ø10, only G is available.

Cylinder stroke (mm)

Bore size (mm)	Standard stroke (mm)*	Maximum manufacturable stroke (mm)
10, 16, 20	50, 100, 150, 200, 250, 300	1000
25, 32, 40	350, 400, 450, 500, 550, 600	1500

* The stroke can be manufactured up to the maximum stroke from 50 mm stroke in 1 mm increments. However, add "XB10" to the end of the part number for non-standard strokes from 51 to 599. Also when exceeding a 600 mm stroke, specify "XB11" at the end of the model number. (Except ø10)

Made to Order
Refer to page 1289 for details.

Number of auto switches

Nil	2 pcs.
S	1 pc.
n	"n" pcs.

Auto switch

Nil	Without auto switch (Built-in magnet)
-----	---------------------------------------

* Refer to the table below for the applicable auto switch model.

For ø10 cylinders without an auto switch, the cylinder configuration is for the reed auto switch. Contact SMC when the solid state auto switch is retrofitted.

End lock position

Nil	Without end lock
E	Right end
F	Left end
W	Both ends

* MY1H10 is not available with end lock.

* For end lock positions, refer to page 1304.

Stroke adjustment unit symbol

Refer to "Stroke adjustment unit" on page 1289.

Intermediate fixing spacer is not available for end lock mounting side.

Applicable Auto Switches

Refer to pages 1559 to 1673 for further information on auto switches.

Type	Special function	Electrical entry	Indication light	Wiring (Output)	Load voltage		Auto switch model		Lead wire length (m)				Pre-wired connector	Applicable load			
					DC	AC	Perpendicular	In-line	0.5 (Nil)	1 (M)	3 (L)	5 (Z)			None (N)		
Solid state auto switch	—	Grommet	Yes	3-wire (NPN)	24 V	5 V, 12 V	M9NV	M9N	●	●	●	○	○	IC circuit	Relay, PLC		
				3-wire (PNP)			M9PV	M9P	●	●	●	○	○				
				2-wire			M9BV	M9B	●	●	●	○	○				
				3-wire (NPN)			M9NVV	M9NV	●	●	●	○	○				
	Diagnostic indication (2-color indication)			Grommet	Yes	3-wire (PNP)	24 V	5 V, 12 V	M9PVV	M9PV	●	●	●	○		○	IC circuit
						2-wire			M9BWW	M9BW	●	●	●	○		○	
						3-wire (NPN)			M9NAV**	M9NA**	○	○	●	○		○	
						3-wire (PNP)			M9PAV**	M9PA**	○	○	●	○		○	
Water resistant (2-color indication)	Grommet	No	2-wire	24 V	12 V	M9BAV**	M9BA**	○	○	●	○	○	—				
			3-wire (NPN equivalent)			A96V	A96	●	—	—	—	—		IC circuit	—		
Reed auto switch	—	Grommet	No	2-wire	24 V	12 V	A93V	A93	●	—	●	—	—	Relay, PLC			
				100 V or less			A90V	A90	●	—	●	—	—		IC circuit		
				100 V or less			A90V	A90	●	—	●	—	—		IC circuit		

** Water resistant type auto switches can be mounted on the above models, but in such case SMC cannot guarantee water resistance. Consult with SMC regarding water resistant types with the above model numbers.

* Lead wire length symbols: 0.5 m Nil (Example) M9NV
1 m M (Example) M9NVW
3 m L (Example) M9NWL
5 m Z (Example) M9NVZ

* Solid state auto switches marked with "○" are produced upon receipt of order.
* Separate switch spacers (BMG2-012) are required to retrofit auto switches (M9 type) on cylinders ø25 to ø40.

* There are other applicable auto switches than listed above. For details, refer to page 1321.

* For details about auto switches with pre-wired connector, refer to pages 1626 and 1627.

* Auto switches are shipped together (not assembled). (Refer to pages 1319 to 1321 for the details of auto switch mounting.)

Mechanically Jointed Rodless Cylinder Linear Guide Type **Series MY1H**

Specifications

Bore size (mm)	10	16	20	25	32	40
Fluid	Air					
Action	Double acting					
Operating pressure range	0.2 to 0.8 MPa (2.0 to 8.2 kgf/cm ²)		0.1 to 0.8 MPa			
Proof pressure	1.2 MPa					
Ambient and fluid temperature	5 to 60°C					
Cushion	Rubber bumper	Air cushion				
Lubrication	Non-lube					
Stroke length tolerance	+1.8 0					
Piping	Front/Slide port	M5 x 0.8	Rc 1/8	Rc 1/4		
	Bottom port	ø4	ø6	ø8		

Made to Order
Made to Order: Individual Specifications
(For details, refer to page 1322.)

Symbol	Specifications
-X168	Helical insert thread specifications

Made to Order Specifications
(For details, refer to pages 1699 to 1818.)

Symbol	Specifications
-XB10	Intermediate stroke (Using exclusive body)
-XB11	Long stroke
-XB22	Shock absorber soft type Series RJ type
-XC56	With knock pin hole
-XC67	NBR rubber lining in dust seal band

Stroke Adjustment Unit Specifications

Bore size (mm)		10	16	20		25		32		40	
Unit symbol		H	A	L	A	L	H	A	L	H	A
Configuration Shock absorber model		RB 0805 + with adjustment bolt	With adjustment bolt RB 0806 + with adjustment bolt	With adjustment bolt RB 0806 + with adjustment bolt	With adjustment bolt RB 1007 + with adjustment bolt	With adjustment bolt RB 1007 + with adjustment bolt	With adjustment bolt RB 1412 + with adjustment bolt	With adjustment bolt RB 1412 + with adjustment bolt	With adjustment bolt RB 2015 + with adjustment bolt	With adjustment bolt RB 1412 + with adjustment bolt	With adjustment bolt RB 2015 + with adjustment bolt
	Stroke adjustment range by intermediate fixing spacer (mm)	Without spacer 0 to -10	0 to -5.6	0 to -6	0 to -12	0 to -11.5	0 to -12	0 to -12	0 to -12	0 to -16	0 to -16
	With short spacer —*1	-5.6 to -11.2	-6 to -12	-11.5 to -23	-12 to -24	-16 to -32	-16 to -32	-23 to -34.5	-24 to -36	-32 to -48	-32 to -48
	With long spacer —*1	-11.2 to -16.8	-12 to -18	-23 to -34.5	-23 to -34.5	-24 to -36	-32 to -48	-32 to -48	-32 to -48	-32 to -48	-32 to -48

- *1) For ø10, stroke adjustment is available. Refer to page 1293 for details.
*2) Stroke adjustment range is applicable for one side when mounted on a cylinder.

Stroke Adjustment Unit Symbol

		Right side stroke adjustment unit											
		Without unit	A: With adjustment bolt			L: With low load shock absorber + Adjustment bolt			H: With high load shock absorber + Adjustment bolt				
Left side stroke adjustment unit	Without unit	Nil	SA	SA6	SA7	SL	SL6	SL7	SH	SH6	SH7		
	A: With adjustment bolt	With short spacer	A6S	A6A	A6A	A6A7	AL	AL6	AL7	AH	AH6	AH7	
With long spacer		A7S	A7A	A7A6	A7	A7L	A7L6	A7L7	A7H	A7H6	A7H7		
With short spacer		L6S	L6A	L6A6	L6A7	L6L	L6L6	L6L7	L6H	L6H6	L6H7		
L: With low load shock absorber + Adjustment bolt	With long spacer	L7S	L7A	L7A6	L7A7	L7L	L7L6	L7L7	L7H	L7H6	L7H7		
	With short spacer	L6S	L6A	L6A6	L6A7	L6L	L6L6	L6L7	L6H	L6H6	L6H7		
	With long spacer	L7S	L7A	L7A6	L7A7	L7L	L7L6	L7L7	L7H	L7H6	L7H7		
H: With high load shock absorber + Adjustment bolt	With short spacer	H6S	H6A	H6A6	H6A7	H6L	H6L6	H6L7	H6H	H6H6	H6H7		
	With long spacer	H7S	H7A	H7A6	H7A7	H7L	H7L6	H7L7	H7H	H7H6	H7H7		
	With short spacer	H6S	H6A	H6A6	H6A7	H6L	H6L6	H6L7	H6H	H6H6	H6H7		
With long spacer	H7S	H7A	H7A6	H7A7	H7L	H7L6	H7L7	H7H	H7H6	H7H7			

- * Intermediate fixing spacer is not available for end lock mounting side.
* Spacers are used to fix the stroke adjustment unit at an intermediate stroke position.

Shock Absorbers for L and H Units

Type	Stroke adjustment unit	Bore size (mm)					
		10	16	20	25	32	40
Standard (Shock absorber/RB series)	L	—	RB0806	RB1007	RB1412	RB2015	
	H	RB0805	—	RB1007	RB1412	RB2015	
Shock absorber/soft type RJ series mounted (-XB22)	L	—	RJ0806H	RJ1007H	RJ1412H		
	H	RJ0805	—	RJ1007H	RJ1412H	—	—

- * The shock absorber service life is different from that of the MY1H cylinder depending on operating conditions. Refer to the RB Series Specific Product Precautions for the replacement period.
* Mounted shock absorber soft type RJ series (-XB22) is made to order specifications. For details, refer to page 1722.

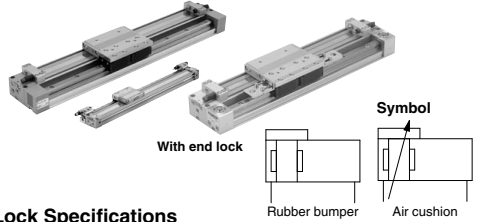

Lock Specifications

Bore size (mm)	16	20	25	32	40
Lock position	One end (Selectable), Both ends				
Holding force (Max.) (N)	110	170	270	450	700
Fine stroke adjustment range (mm)	0 to -5.6	0 to -6	0 to -11.5	0 to -12	0 to -16
Backlash	1 mm or less				
Manual release	Possible (Non-lock type)				

Piston Speed

Bore size (mm)		10	16 to 40
Without stroke adjustment unit		100 to 500 mm/s	100 to 1000 mm/s
Stroke adjustment unit	A unit	100 to 200 mm/s	100 to 1000 mm/s ⁽¹⁾
	L unit and H unit	100 to 1000 mm/s	100 to 1500 mm/s ⁽²⁾

Note 1) Be aware that when the stroke adjustment range is increased by manipulating the adjustment bolt, the air cushion capacity decreases. Also, when exceeding the air cushion stroke ranges on page 1291, the piston speed should be 100 to 200 mm per second.

- Note 2) The piston speed is 100 to 1000 mm/s for centralized piping.
Note 3) Use at a speed within the absorption capacity range. Refer to page 1291.

Stroke adjustment unit mounting diagram

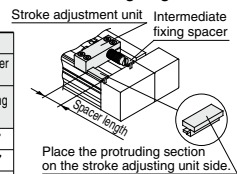

Place the protruding section on the stroke adjusting unit side.

Example of L6L7 attachment

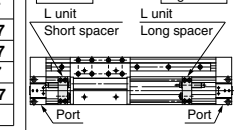

Shock Absorber Specifications

Model	RB 0805	RB 0806	RB 1007	RB 1412	RB 2015	
Max. energy absorption (J)	1.0	2.9	5.9	19.6	58.8	
Stroke absorption (mm)	5	6	7	12	15	
Max. collision speed (mm/s)	1000	1500	1500	1500	1500	
Max. operating frequency (cycle/min)	80	80	70	45	25	
Spring force (N)	Extended	1.96	1.96	4.22	6.86	8.34
	Retracted	3.83	4.22	6.86	15.98	20.50
Operating temperature range (°C)	5 to 60					

- * The shock absorber service life is different from that of the MY1H cylinder depending on operating conditions. Refer to the RB Series Specific Product Precautions for the replacement period.

Series MY1H

Theoretical Output

Bore size (mm)	Piston area (mm ²)	Operating pressure (MPa)						
		0.2	0.3	0.4	0.5	0.6	0.7	0.8
10	78	15	23	31	39	46	54	62
16	200	40	60	80	100	120	140	160
20	314	62	94	125	157	188	219	251
25	490	98	147	196	245	294	343	392
32	804	161	241	322	402	483	563	643
40	1256	251	377	502	628	754	879	1005

Note) Theoretical output (N) = Pressure (MPa) x Piston area (mm²)

Weight

Bore size (mm)	Basic weight	Additional weight per each 50 mm of stroke	Weight of moving parts	Side support bracket weight (per set) Type A and B	Stroke adjustment unit weight (per unit)		
					A unit weight	L unit weight	H unit weight
10	0.26	0.08	0.05	0.003	—	—	0.02
16	0.74	0.14	0.19	0.01	0.02	0.04	—
20	1.35	0.25	0.40	0.02	0.03	0.05	0.07
25	2.31	0.30	0.73	0.02	0.04	0.07	0.11
32	4.65	0.46	1.30	0.04	0.08	0.14	0.23
40	6.37	0.55	1.89	0.08	0.12	0.19	0.28

Calculation: (Example) MY1H25-300A

- Basic weight 2.31 kg
- Cylinder stroke 300 stroke
- Additional weight 0.30/50 stroke
2.31 + 0.30 x 300/50 + 0.04 x 2 ≒ 4.19 kg
- Weight of A unit 0.06 kg

Option

Stroke Adjustment Unit Part No.

MYH-A 25 L2 - 6N

Stroke adjustment unit

Bore size

10	10 mm
16	16 mm
20	20 mm
25	25 mm
32	32 mm
40	40 mm

Unit no.

Symbol	Stroke adjustment unit	Mounting position
A1	A unit	Left
A2	A unit	Right
L1	L unit	Left
L2	L unit	Right
H1	H unit	Left
H2	H unit	Right

Note 1) Refer to page 1289 for details about adjustment range.

Note 2) H unit only for ø10, A and L unit only for ø16

Stroke adjustment unit

Intermediate fixing spacer

Spacer delivery style

Nil	Without spacer
6	Short spacer
7	Long spacer

Spacer length

Place the protruding section on the stroke adjustment unit side.

* When ordering the intermediate fixing spacer for the stroke adjustment unit, the intermediate fixing spacer is shipped together.

Component Parts

MYH-A25L2 (Without spacer)	MYH-A25L2-6 (With short spacer)	MYH-A25L2-7 (With long spacer)	MYH-A25L2-6N (Short spacer only)
			MYH-A25L2-7N (Long spacer only)

* Nuts are equipped on the cylinder body.

Side Support Part No.

Bore size (mm) Type	10	16	20	25	32	40
Side support A	MY-S10A	MY-S16A	MY-S20A	MY-S25A	MY-S32A	MY-S40A
Side support B	MY-S10B	MY-S16B	MY-S20B	MY-S25B	MY-S32B	MY-S40B

For details about dimensions, etc., refer to page 1305.

A set of side supports consists of a left support and a right support.

Cushion Capacity

Cushion Selection

<Rubber bumper>

Rubber bumpers are a standard feature on MY1H10.

Since the stroke absorption of rubber bumpers is short, when adjusting the stroke with an A unit, install an external shock absorber.

The load and speed range which can be absorbed by a rubber bumper is inside the rubber bumper limit line of the graph.

<Air cushion>

Air cushions are a standard feature on mechanically jointed rodless cylinders.

The air cushion mechanism is incorporated to prevent excessive impact of the piston at the stroke end during high speed operation. The purpose of air cushion, thus, is not to decelerate the piston near the stroke end.

The ranges of load and speed that air cushions can absorb are within the air cushion limit lines shown in the graphs.

<Stroke adjustment unit with shock absorber>

Use this unit when operating with a load or speed exceeding the air cushion limit line, or when cushioning is required outside of the effective air cushion stroke range due to stroke adjustment.

L unit

Use this unit when the cylinder stroke is outside of the effective air cushion range even if the load and speed are within the air cushion limit line, or when the cylinder is operated in a load and speed range above the air cushion limit line or below the L unit limit line.

H unit

Use this unit when the cylinder is operated in a load and speed range above the L unit limit line and below the H unit limit line.

⚠ Caution

1. Refer to the figure below when using the adjustment bolt to perform stroke adjustment.

When the effective stroke of the shock absorber decreases as a result of stroke adjustment, the absorption capacity decreases dramatically. Secure the adjusting bolt at the position where it protrudes approximately 0.5 mm from the shock absorber.

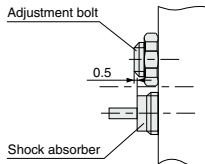

2. Do not use a shock absorber together with air cushion.

Air Cushion Stroke

(mm)

Bore size (mm)	Cushion stroke
16	12
20	15
25	15
32	19
40	24

Absorption Capacity of Rubber Bumper, Air cushion and Stroke Adjustment Units

MY1H10

Horizontal collision: P = 0.5 MPa

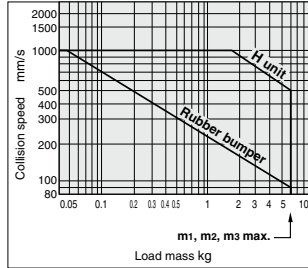

MY1H32

Horizontal collision: P = 0.5 MPa

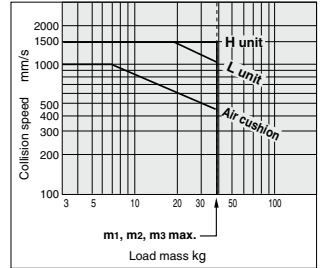

MY1H16

Horizontal collision: P = 0.5 MPa

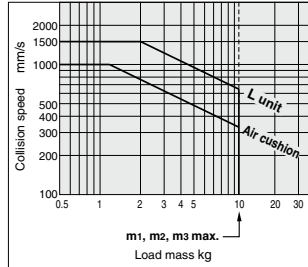

MY1H40

Horizontal collision: P = 0.5 MPa

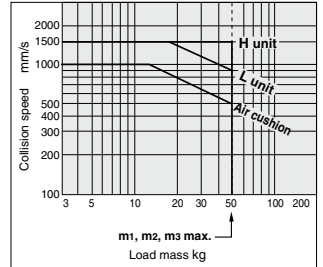

MY1H20

Horizontal collision: P = 0.5 MPa

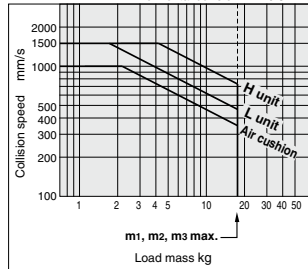

MY1H25

Horizontal collision: P = 0.5 MPa

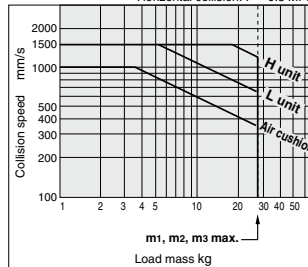

MY1B
-Z

MY1H
-Z

MY1B

MY1M

MY1C

MY1H

MY1
HT

MY1
□W

MY2C

MY2
□H

MY3A

MY3B

MY3M

D-□

-X□

Technical
data



Series MY1H

Cushion Capacity

Tightening Torque for Stroke Adjustment Unit Holding Bolts (N·m)

Bore size (mm)	Tightening torque
10	Refer to the adjustment procedures on page 1293.
16	0.7
20	1.8
25	1.8
32	3.5
40	5.8

Calculation of Absorbed Energy for Stroke Adjustment Unit with Shock Absorber (N·m)

Type of impact	Horizontal collision	Vertical (Downward)	Vertical (Upward)
			
Kinetic energy E ₁	$\frac{1}{2} m \cdot v^2$		
Thrust energy E ₂	F · s	F · s + m · g · s	F · s - m · g · s
Absorbed energy E	E ₁ + E ₂		

Symbol

v: Speed of impact object (m/s)

F: Cylinder thrust (N)

s: Shock absorber stroke (m)

m: Weight of impact object (kg)

g: Gravitational acceleration (9.8 m/s²)

Note) The speed of the impact object is measured at the time of impact with the shock absorber.

Rubber Bumper (ø10 only) Positive Stroke from One End Due to Pressure

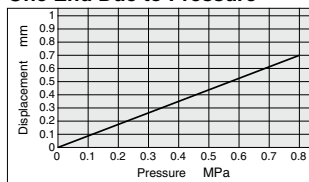



Series MY1H

Specific Product Precautions 1

Be sure to read before handling.

Refer to front matter 57 for Safety Instructions and pages 3 to 12 for Actuator and Auto Switch Precautions.

⚠ Caution

Use caution not to get your hands caught in the unit.

- When using a product with stroke adjustment unit, the space between the slide table (slider) and the stroke adjustment unit becomes narrow at the stroke end, causing a danger of hands getting caught. Install a protective cover to prevent direct contact with the human body.

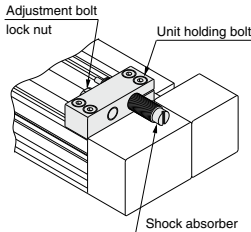

<Fastening of unit>

The unit can be secured by evenly tightening the four unit holding bolts.

⚠ Caution

Do not operate with the stroke adjustment unit fixed in an intermediate position.

When the stroke adjustment unit is fixed in an intermediate position, slippage can occur depending on the amount of energy released at the time of an impact. In such cases, as a stroke adjustment unit with the spacer for intermediate securing is available, it is recommended to use it. (Except $\phi 10$)

For other lengths, please consult with SMC (Refer to "Tightening Torque for Stroke Adjustment Unit Holding Bolts".)

<Stroke adjustment with adjustment bolt>

Loosen the adjustment bolt lock nut, and adjust the stroke from the head cover side using a hexagon wrench. Re-tighten the lock nut.

<Stroke adjustment with shock absorber>

Loosen the two unit holding bolts on the shock absorber side, turn the shock absorber and adjust the stroke. Then, uniformly tighten the unit holding bolts to secure the shock absorber.

Take care not to over-tighten the holding bolts. (Except $\phi 10$, $\phi 16$, $\phi 20$) (Refer to "Tightening Torque for Stroke Adjustment Unit Holding Bolts".)

⚠ Caution

To adjust the stroke adjustment unit of the MY1H10, follow the step shown below.

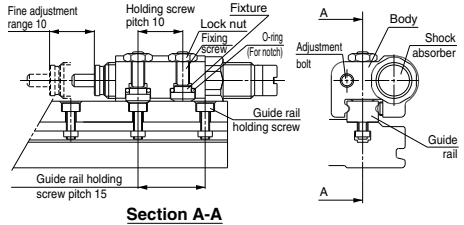

Adjusting Procedure

- Loosen the two lock nuts, and then loosen the holding screws by turning them approximately two turns.
- Move the body to the notch just before the desired stroke. (The notches are found in alternating increments of 5 mm and 10 mm.)
- Tighten the holding screw to 0.3 N·m. Make sure that the tightening does not cause excessive torque. The fixture fits into the fastening hole in the guide rail to prevent slippage, which enables fastening with low torque.
- Tighten the lock nut to 0.6 N·m.
- Make fine adjustments with the adjustment bolt and shock absorber.

MY1B
-Z

MY1H
-Z

MY1B

MY1M

MY1C

MY1H

MY1
HT

MY1
□W

MY2C

MY2
H□

MY3A
MY3B

MY3M

D-□

-X□

Technical
data



Series MY1H

Specific Product Precautions 2

Be sure to read before handling.

Refer to front matter 57 for Safety Instructions and pages 3 to 12 for Actuator and Auto Switch Precautions.

With End Locks

Recommended Pneumatic Circuit

⚠ Caution

This is necessary for the correct locking and unlocking actions.

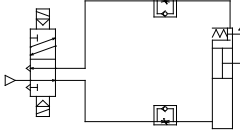

Operating Precautions

⚠ Caution

1. Do not use 3 position solenoid valves.

Avoid use in combination with 3 position solenoid valves (especially closed center metal seal types). If pressure is trapped in the port on the lock mechanism side, the cylinder cannot be locked.

Furthermore, even after being locked, the lock may be released after some time due to air leaking from the solenoid valve and entering the cylinder.

2. Back pressure is required when releasing the lock.

Before starting operation, be sure to control the system so that air is supplied to the side without the lock mechanism (in case of locks on both ends, the side where the slide table is not locked) as shown in the figure above. There is a possibility that the lock may not be released. (Refer to the section on releasing the lock.)

3. Release the lock when mounting or adjusting the cylinder.

If mounting or other work is performed when the cylinder is locked, the lock unit may be damaged.

4. Operate at 50% or less of the theoretical output.

If the load exceeds 50% of the theoretical output, this may cause problems such as failure of the lock to release, or damage to the lock unit.

5. Do not operate multiple cylinders in synchronization.

Avoid applications in which two or more end lock cylinders are synchronized to move one workpiece, as one of the cylinder locks may not be able to release when required.

6. Use a speed controller with meter-out control.

Lock cannot be released occasionally by meter-in control.

7. Be sure to operate completely to the cylinder stroke end on the side with the lock.

If the cylinder piston does not reach the end of the stroke, locking and unlocking may not be possible. (Refer to the section on adjusting the end lock mechanism.)

Operating Pressure

⚠ Caution

1. Supply air pressure of 0.15 MPa or higher to the port on the side that has the lock mechanism, as it is necessary for disengaging the lock.

Exhaust Speed

⚠ Caution

1. Locking will occur automatically if the pressure applied to the port on the lock mechanism side falls to 0.05 MPa or less. In the cases where the piping on the lock mechanism side is long and thin, or the speed controller is separated at some distance from the cylinder port, the exhaust speed will be reduced. Take note that some time may be required for the lock to engage.

In addition, clogging of a silencer mounted on the solenoid valve exhaust port can produce the same effect.

Relation to Cushion

⚠ Caution

1. When the air cushion on the lock mechanism side is in a fully closed or nearly closed state, there is a possibility that the slide table will not reach the stroke end, in which case locking will not occur.

Adjusting the End Lock Mechanism

⚠ Caution

1. The end lock mechanism is adjusted at the time of shipping. Therefore, adjustment for operation at the stroke end is unnecessary.

2. The end lock mechanism after the stroke adjustment unit has been adjusted. The adjustment bolt and shock absorber of the stroke adjustment unit must be adjusted and secured first. Locking and unlocking may not occur otherwise.

3. Perform fine adjustment of the end lock mechanism as follows. Loosen the lock finger holding bolts, and then adjust by aligning the center of the lock piston with the center of the lock finger hole. Secure the lock finger.

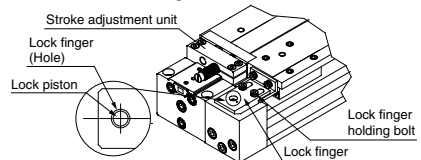

Releasing the Lock

⚠ Warning

1. Before releasing the lock, be sure to supply air to the side without the lock mechanism, so that there is no load applied to the lock mechanism when it is released. (Refer to the recommended pneumatic circuits.) If the lock is released when the port on the side without the lock is in an exhaust state, and with a load applied to the lock unit, the lock unit may be subjected to an excessive force and be damaged. Furthermore, sudden movement of the slide table is very dangerous.

Manual Release

⚠ Caution

1. When manually releasing the end lock, be sure to release the pressure.

If it is unlocked while the air pressure still remains, it will lead to damage a workpiece, etc. due to unexpected lurching.

2. Perform manual release of the end lock mechanism as follows. Push the lock piston down with a screwdriver, etc., and move the slide table.

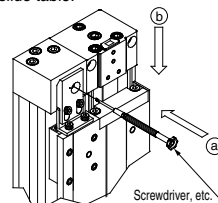

Other handling precautions regarding mounting, piping, and environment are the same as the standard series.

Construction: $\varnothing 10$

Centralized piping type

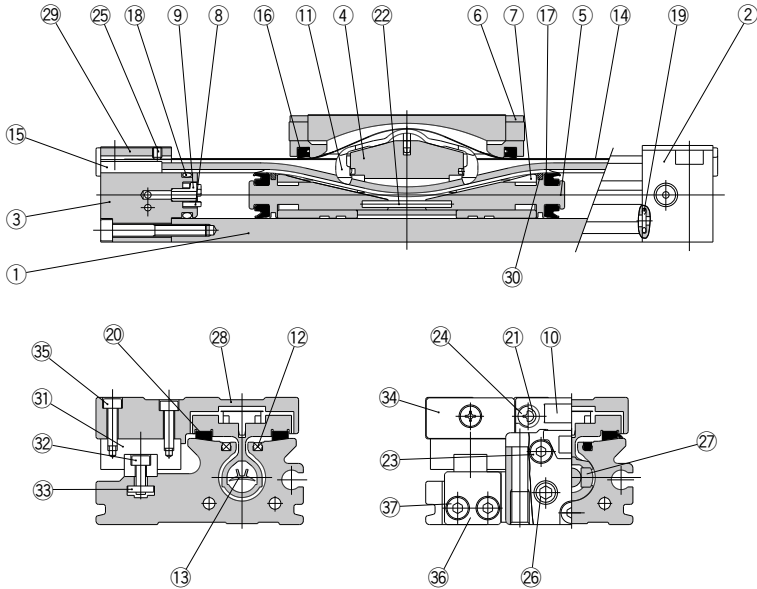

Component Parts

No.	Description	Material	Note
1	Cylinder tube	Aluminum alloy	Hard anodized
2	Head cover WR	Aluminum alloy	Painted
3	Head cover WL	Aluminum alloy	Painted
4	Piston yoke	Aluminum alloy	Hard anodized
5	Piston	Aluminum alloy	Chromated
6	End cover	Special resin	
7	Wear ring	Special resin	
8	Bumper	Polyurethane rubber	
9	Holder	Stainless steel	
10	Stopper	Carbon steel	Nickel plated
11	Belt separator	Special resin	
12	Seal magnet	Rubber magnet	
15	Belt clamp	Special resin	
20	Bearing	Special resin	
21	Spacer	Chromium molybdenum steel	Nickel plated

No.	Description	Material	Note
22	Spring pin	Stainless steel	
23	Hexagon socket head cap screw	Chromium molybdenum steel	Nickel plated
24	Round head Phillips screw	Carbon steel	Nickel plated
25	Hexagon socket head set screw	Carbon steel	Black zinc chromated
26	Hexagon socket head plug	Carbon steel	Nickel plated
27	Magnet	—	
28	Slide table	Aluminum alloy	Hard anodized
29	Head plate	Stainless steel	
30	Felt	Felt	
31	Linear guide	—	
32	Hexagon socket head cap screw	Chromium molybdenum steel	Nickel plated
33	Square nut	Carbon steel	Nickel plated
34	Stopper plate	Carbon steel	Nickel plated
35	Hexagon socket head cap screw	Chromium molybdenum steel	Nickel plated
36	Guide stopper	Carbon steel	Nickel plated
37	Hexagon socket head cap screw	Chromium molybdenum steel	Nickel plated

Replacement Part: Seal Kit

No.	Description	Qty.	MY1H10
13	Seal belt	1	MY10-16A-Stroke
14	Dust seal band	1	MY10-16B-Stroke
16	Scraper	2	MY1B10-PS
17	Piston seal	2	
18	Tube gasket	2	
19	O-ring	4	

* Seal kit includes 16, 17, 18 and 19.

Seal kit includes a grease pack (10 g).

When 13 and 14 are shipped independently, a grease pack is included.

Order with the following part number when only the grease pack is needed.

Grease pack part number: GR-S-010 (10 g), GR-S-020 (20 g)

MY1B

-Z

MY1H

-Z

MY1B

MY1M

MY1C

MY1H

MY1

HT

MY1

□W

MY2C

MY2

□H

MY3A

MY3B

MY3M

MY3M

MY3M

MY3M

MY3M

MY3M

MY3M

MY3M

MY3M

MY3M

MY3M

MY3M

MY3M

MY3M

MY3M

MY3M

MY3M

MY3M

MY3M

MY3M

MY3M

MY3M

MY3M

MY3M

MY3M

MY3M

MY3M

MY3M

MY3M

MY3M

MY3M

MY3M

Series MY1H

Construction: $\varnothing 16$ to $\varnothing 40$

MY1H16 to 40

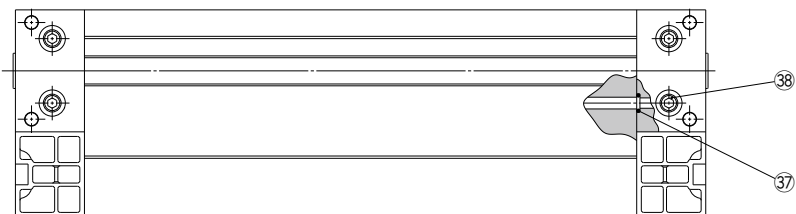
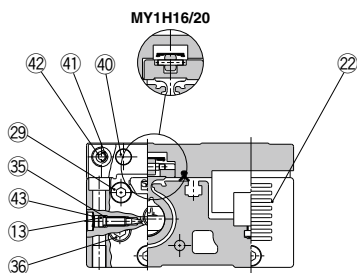
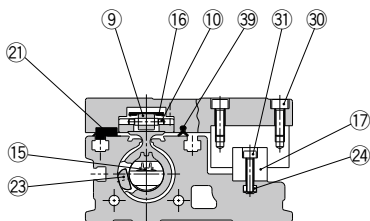
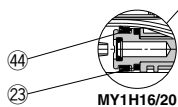
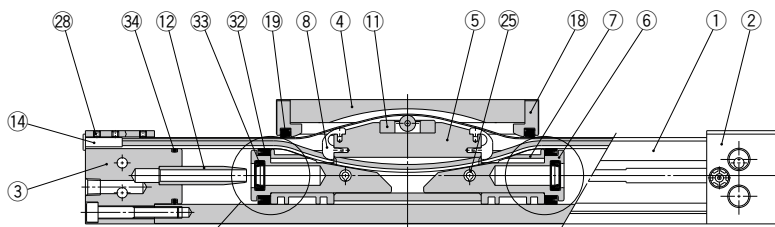

MY1H16 to 40

Component Parts

No.	Description	Material	Note
1	Cylinder tube	Aluminum alloy	Hard anodized
2	Head cover WR	Aluminum alloy	Painted
3	Head cover WL	Aluminum alloy	Painted
4	Slide table	Aluminum alloy	Hard anodized
5	Piston yoke	Aluminum alloy	Chromated
6	Piston	Aluminum alloy	Chromated
7	Wear ring	Special resin	
8	Belt separator	Special resin	
9	Guide roller	Special resin	
10	Guide roller shaft	Stainless steel	
11	Coupler	Sintered iron material	
12	Cushion ring	Aluminum alloy	Anodized
13	Cushion needle	Rolled steel	Nickel plated
14	Belt clamp	Special resin	
17	Guide		
18	End cover	Special resin	
21	Bearing	Special resin	
22	Guide cover	Special resin	

No.	Description	Material	Note
23	Magnet	—	
24	Square nut	Carbon steel	Nickel plated
25	Spring pin	Carbon tool steel	
28	Hexagon socket head set screw	Chromium molybdenum steel	Black zinc chromated/Nickel plated
29	Hexagon socket head cap screw	Chromium molybdenum steel	Nickel plated
30	Hexagon socket head cap screw	Chromium molybdenum steel	Nickel plated
31	Hexagon socket head cap screw	Chromium molybdenum steel	Nickel plated
36	Hexagon socket head taper plug	Carbon steel	Nickel plated
38	Hexagon socket head taper plug	Carbon steel	Nickel plated
40	Stopper	Carbon steel	Nickel plated
41	Spacer	Stainless steel	
42	Hexagon socket button head screw	Chromium molybdenum steel	Nickel plated
43	Type CR retaining ring	Spring steel	
44	Lube retainer	Special resin	(ø16, ø20)

Replacement Part: Seal Kit

No.	Description	Qty.	MY1H16	MY1H20	MY1H25	MY1H32	MY1H40
15	Seal belt	1	MY16-16A-Stroke	MY20-16A-Stroke	MY25-16A-Stroke	MY32-16A-Stroke	MY40-16A-Stroke
16	Dust seal band	1	MY16-16B-Stroke	MY20-16B-Stroke	MY25-16B-Stroke	MY32-16B-Stroke	MY40-16B-Stroke
35	O-ring	2	KA00309 (ø4 x ø1.8 x ø1.1)	KA00309 (ø4 x ø1.8 x ø1.1)	KA00311 (ø5.1 x ø3 x ø1.05)	KA00320 (ø7.15 x ø3.75 x ø1.7)	KA00320 (ø7.15 x ø3.75 x ø1.7)
39	Side scraper	1	MYH16-15BK2900B	MYH20-15BK2901B	MYH25-15BK2902B	MYH32-15BK2903B	MYH40-15BK2904B
19	Scraper	2					
32	Piston seal	2	MY1H16-PS	MY1H20-PS	MY1H25-PS	MY1H32-PS	MY1H40-PS
33	Cushion seal	2					
34	Tube gasket	2					
37	O-ring	4					

* Seal kit includes 19, 32, 33, 34 and 37. Order the seal kit based on each bore size.

* Seal kit includes a grease pack (10 g).

When 15 and 16 are shipped independently, a grease pack (20 g) is included.

Order with the following part number when only the grease pack is needed.

Grease pack part number: GR-S-010 (10 g), GR-S-020 (20 g)

Note Two kinds of dust seal bands are available. Verify the type to use, since the part number varies depending on the treatment of the hexagon socket head set screw 28.

A: Black zinc chromated → MY□□-16B-stroke, B: Nickel plated → MY□□-16BW-stroke

MY1B
-Z

MY1H
-Z

MY1B

MY1M

MY1C

MY1H

MY1
HT

MY1
□W

MY2C

MY2
□H

MY3A
MY3B

MY3M

D-□

-X□

Technical
data

Series MY1H

Construction: $\varnothing 16$ to $\varnothing 40$

With End Lock

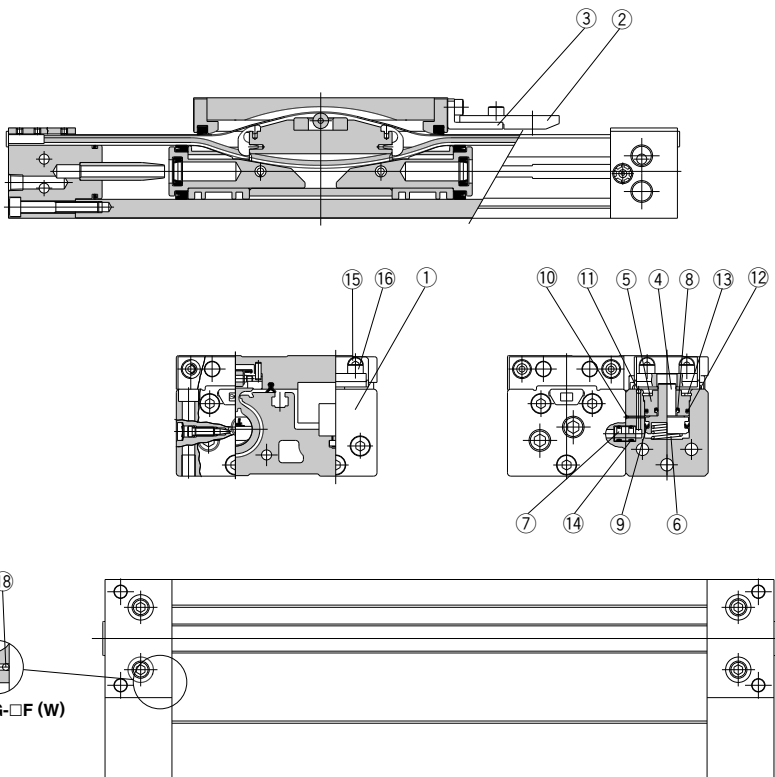

Component Parts

No.	Description	Material	Note
1	Locking body	Aluminum alloy	Painted
2	Lock finger	Carbon steel	After quenching, nickel plated
3	Lock finger bracket	Rolled steel	Nickel plated
4	Lock piston	Carbon tool steel	After quenching, electroless nickel plated
5	Rod cover	Aluminum alloy	Hard anodized
6	Return spring	Spring steel	Zinc chromated
7	Bypass pipe	Aluminum alloy	Chromated
10	Steel ball	High carbon chrome bearing steel	
11	Steel ball	High carbon chrome bearing steel	
13	Round type R retaining ring	Carbon tool steel	Nickel plated
14	O-ring	NBR	
15	Hexagon socket head cap screw	Chromium molybdenum steel	Nickel plated
16	Hexagon socket head cap screw	Chromium molybdenum steel	Nickel plated
17	Steel ball	High carbon chrome bearing steel	
18	Steel ball	High carbon chrome bearing steel	

Replacement Part: Seal Kit

No.	Description	Material	Qty.	MY1H16	MY1H20	MY1H25	MY1H32	MY1H40
8	Rod seal	NBR	1	KB00257	KB00257	KB00267	KB00267	KB00267
9	Piston seal	NBR	1	KB00202	KB00202	KB00217	KB00217	KB00217
12	O-ring	NBR	1	KA00057	KA00057	KA00037	KA00037	KA00037

** Since the seal kit does not include a grease pack, order it separately.

Grease pack part no.: GR-S-010 (10 g)

Mechanically Jointed Rodless Cylinder Linear Guide Type *Series MY1H*

Centralized Piping Type $\phi 10$

Refer to page 1325 regarding centralized piping port variations.

MY1H10G — Stroke

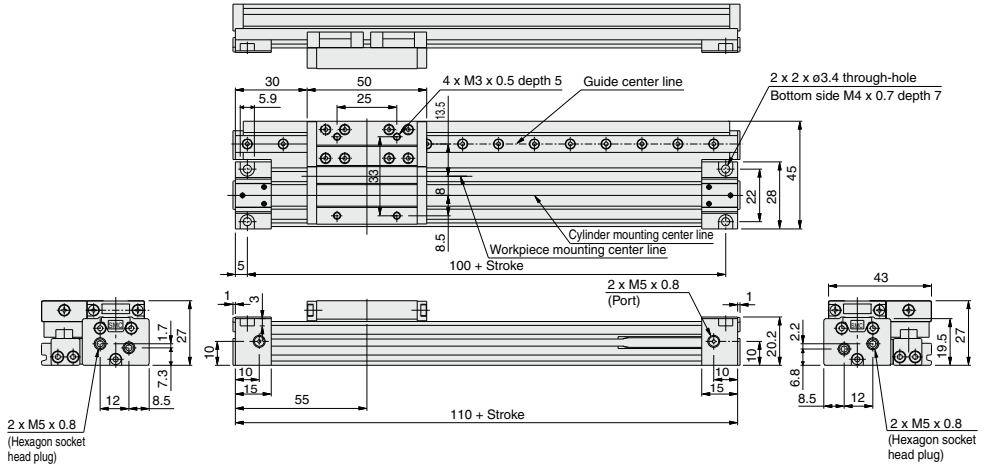

With shock absorber + Adjustment bolt

MY1H10G — Stroke H

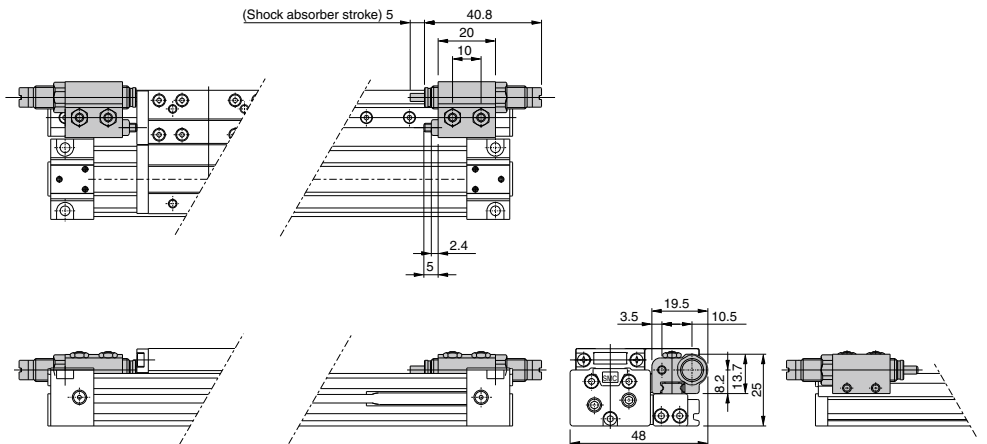

MY1B

-Z

MY1H

-Z

MY1B

MY1M

MY1C

MY1H

MY1

HT

MY1

□W

MY2C

MY2

H□

MY3A

MY3B

MY3M

D-□

-X□

Technical data

Series MY1H

Standard Type/Centralized Piping Type $\phi 16, \phi 20$

Refer to page 1325 regarding centralized piping port variations.

MY1H16□/20□ – Stroke

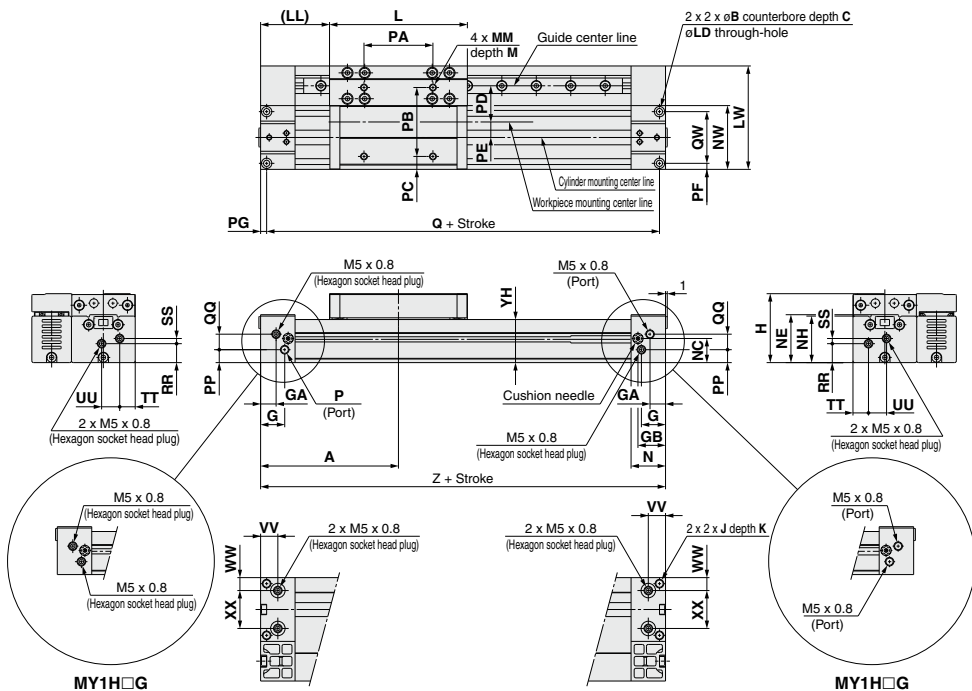

Model	A	B	C	G	GA	GB	H	J	K	L	LD	LL	LW	M	MM	N	NC	NE	NH	NW
MY1H16□	80	6	3.5	14	9	16	40	M5 x 0.8	10	80	3.5	40	60	7	M4 x 0.7	20	14	27.8	27	37
MY1H20□	100	7.5	4.5	12.5	12.5	20.5	46	M6 x 1	12	100	4.5	50	78	8	M5 x 0.8	25	17.5	34	33.5	45

Model	PA	PB	PC	PD	PE	PF	PG	PP	Q	QQ	QW	RR	SS	TT	UU	VV	WW	XX	YH	Z
MY1H16□	40	40	7.5	21	9	3.5	3.5	7.5	153	9	30	11	3	9	10.5	10	7.5	22	25	160
MY1H20□	50	40	14.5	27	12	4.5	4.5	11.5	191	11	36	14.5	5	10.5	12	12.5	10.5	24	31.5	200

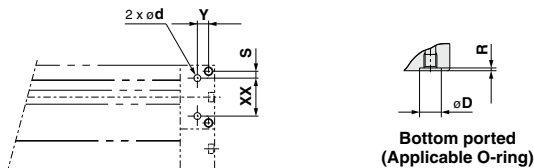

Hole Size for Centralized Piping on the Bottom

Model	WX	Y	S	d	D	R	Applicable O-ring
MY1H16□	22	6.5	4	4	8.4	1.1	C6
MY1H20□	24	8	6	4	8.4	1.1	

(Machine the mounting side to the dimensions below.)

Mechanically Jointed Rodless Cylinder Linear Guide Type *Series MY1H*

Standard Type/Centralized Piping Type $\phi 25, \phi 32, \phi 40$

Refer to page 1325 regarding centralized piping port variations.

MY1H25□/32□/40□ – Stroke

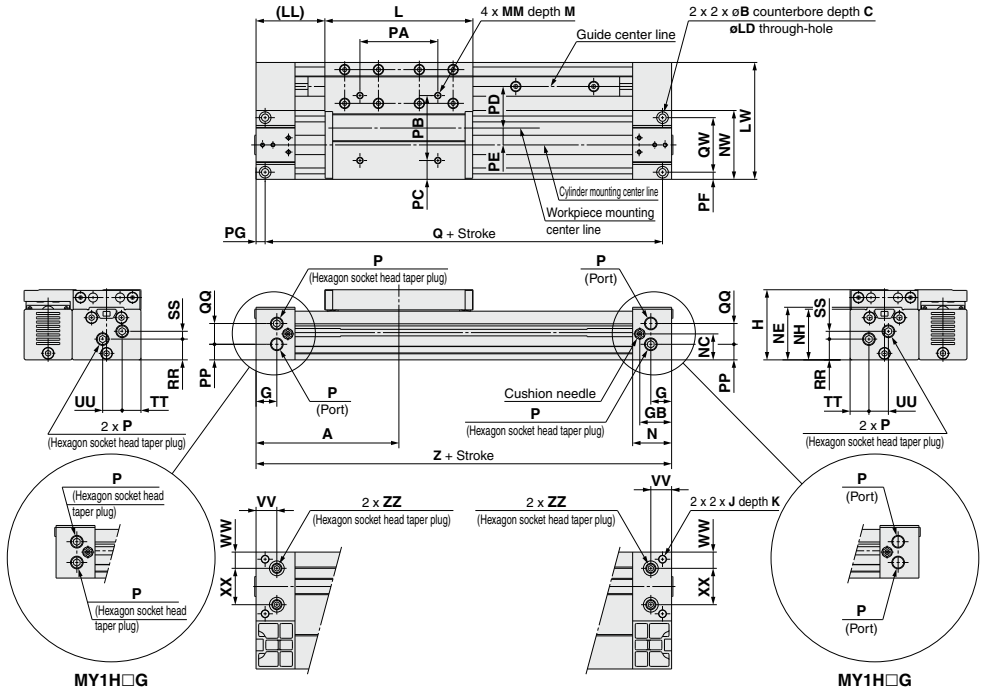

Model	A	B	C	G	GB	H	J	K	L	LD	LL	LW	M	MM	N	NC	NE	NH	NW	P
MY1H25□	110	9	5.5	16	24.5	54	M6 x 1	9.5	114	5.4	53	90	9	M5 x 0.8	30	20	40.5	39	53	Rc 1/8
MY1H32□	140	11	6.6	19	30	68	M8 x 1.25	16	140	6.8	70	110	13	M6 x 1	37	25	50	49	64	Rc 1/8
MY1H40□	170	14	8.5	23	36.5	84	M10 x 1.5	15	170	8.6	85	121	13	M6 x 1	45	30.5	63	61.5	75	Rc 1/4

(mm)

*"P" indicates cylinder supply ports.

Model	PA	PB	PC	PD	PE	PF	PG	PP	Q	QQ	QW	RR	SS	TT	UU	VV	WW	XX	YH	Z	ZZ
MY1H25□	60	50	14.5	32	13	5.5	7	12	206	16	42	16	6	14.5	15	16	12.5	28	37.5	220	Rc 1/16
MY1H32□	80	60	15	42	13	6.5	8	17	264	16	51	23	4	16	16	19	16	32	47	280	Rc 1/16
MY1H40□	100	80	20.5	37.5	23	8	9	18.5	322	24	59	27	10.5	20	22	23	19.5	36	59.5	340	Rc 1/8

(mm)

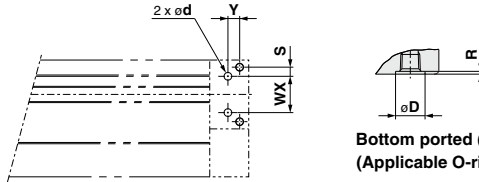

**Bottom ported (ZZ)
(Applicable O-ring)**

Hole Size for Centralized Piping on the Bottom

Model	WX	Y	S	d	D	R	Applicable O-ring
MY1H25□	28	9	7	6	11.4	1.1	C9
MY1H32□	32	11	9.5	6	11.4	1.1	
MY1H40□	36	14	11.5	8	13.4	1.1	

(Machine the mounting side to the dimensions below.)

MY1B

-Z

MY1H

-Z

MY1B

MY1M

MY1C

MY1H

HT

MY1

□W

MY2C

MY2

□H

MY3A

MY3B

MY3M

MY3M

MY3M

MY3M

MY3M

MY3M

MY3M

MY3M

MY3M

MY3M

MY3M

MY3M

MY3M

MY3M

MY3M

MY3M

MY3M

MY3M

MY3M

MY3M

MY3M

MY3M

MY3M

MY3M

MY3M

MY3M

MY3M

MY3M

MY3M

MY3M

MY3M

MY3M

MY3M

MY3M

MY3M

Series MY1H

Stroke Adjustment Unit

With adjustment bolt

MY1H Bore size - Stroke A

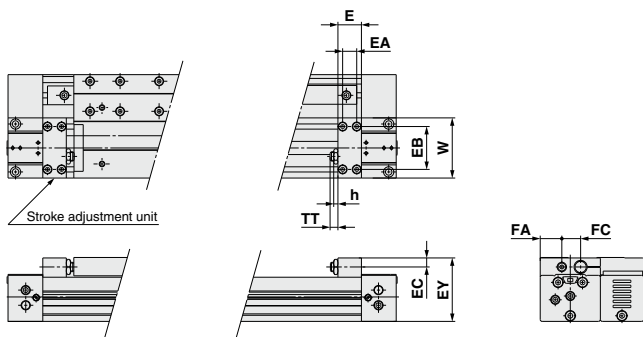

Applicable bore size	E	EA	EB	EC	EY	FA	FC	h	TT	W
MY1H16	14.6	7	28	5.8	39.5	11.5	13	3.6	5.4 (Max. 11)	37
MY1H20	19	10	33	5.8	45.5	15	14	3.6	6 (Max. 12)	45
MY1H25	18	9	40	7.5	53.5	16	21	3.5	5 (Max. 16.5)	53
MY1H32	25	14	45.6	9.5	67.5	23	20	4.5	8 (Max. 20)	64
MY1H40	31	19	55	11	82	24.5	26	4.5	9 (Max. 25)	75

With low load shock absorber + Adjustment bolt

MY1H Bore size - Stroke L

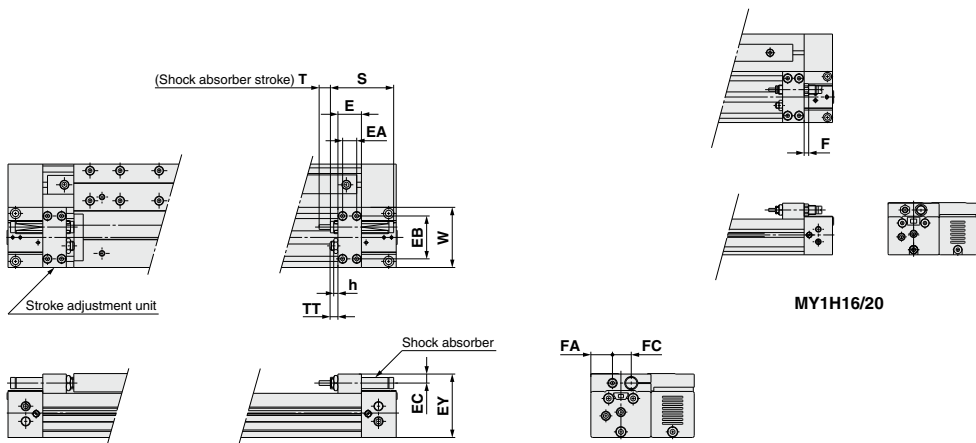

Applicable bore size	E	EA	EB	EC	EY	F	FA	FC	h	S	T	TT	W	Shock absorber model
MY1H16	14.6	7	28	5.8	39.5	4	11.5	13	3.6	40.8	6	5.4 (Max. 11)	37	RB0806
MY1H20	19	10	33	5.8	45.5	4	15	14	3.6	40.8	6	6 (Max. 12)	45	RB0806
MY1H25	18	9	40	7.5	53.5	—	16	21	3.5	46.7	7	5 (Max. 16.5)	53	RB1007
MY1H32	25	14	45.6	9.5	67.5	—	23	20	4.5	67.3	12	8 (Max. 20)	64	RB1412
MY1H40	31	19	55	11	82	—	24.5	26	4.5	67.3	12	9 (Max. 25)	75	RB1412

Stroke Adjustment Unit

With high load shock absorber + Adjustment bolt

MY1H Bore size - Stroke H

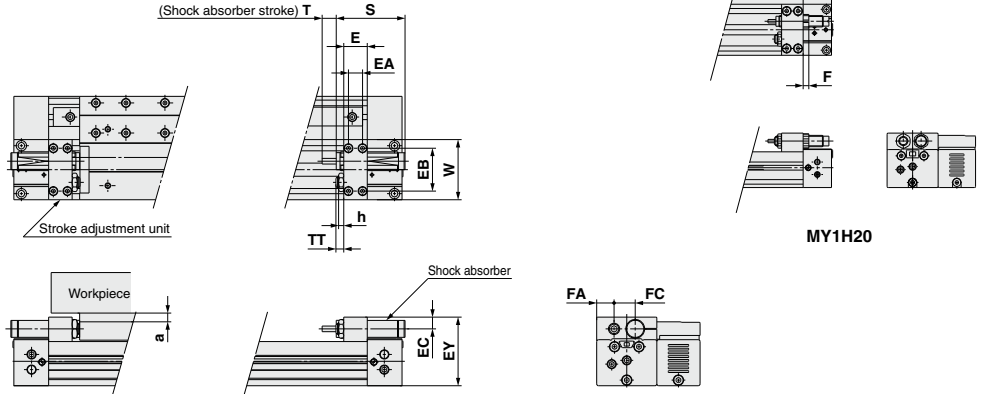

MY1H20

* Since dimension EY of the H type unit is greater than the table top height (dimension H), when mounting a workpiece that exceeds the overall length (dimension L) of the slide table, allow a clearance of dimension "a" or larger on the workpiece side.

Applicable bore size	E	EA	EB	EC	EY	F	FA	FC	h	S	T	TT	W	Shock absorber model	a
MY1H20	19	10	33	7.7	49.5	5	14.3	15.7	3.5	46.7	7	6 (Max. 12)	45	RB1007	4
MY1H25	18	9	40	9	57	—	18	17.5	4.5	67.3	12	5 (Max. 16.5)	53	RB1412	3.5
MY1H32	25	14	45.6	12.4	73	—	18.5	22.5	5.5	73.2	15	8 (Max. 20)	64	RB2015	5.5
MY1H40	31	19	55	12.4	86	—	26.5	22	5.5	73.2	15	9 (Max. 25)	75	RB2015	2.5

MY1B
-Z

MY1H
-Z

MY1B

MY1M

MY1C

MY1H

MY1
HT

MY1
□W

MY2C

MY2
□

MY3A
MY3B

MY3M

D-□

-X□

Technical
data

Series MY1H

With End Lock $\varnothing 16$ to $\varnothing 40$

[Dimensions for types other than end lock are identical to the standard type dimensions. For details about dimensions, etc., refer to pages 1300 and 1301.]

MY1H□—□E
(Right end)

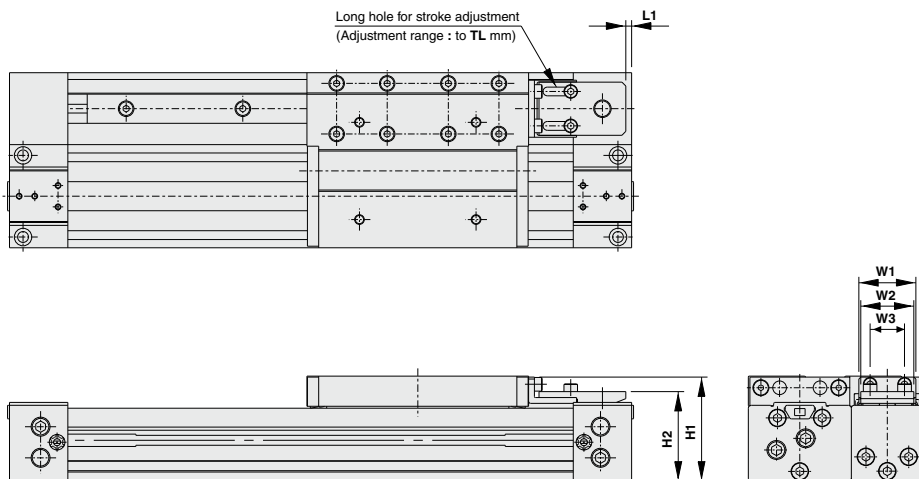

MY1H□—□F
(Left end)

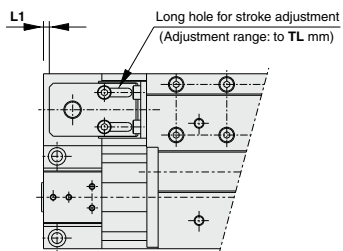

MY1H□—□W
(Both ends)

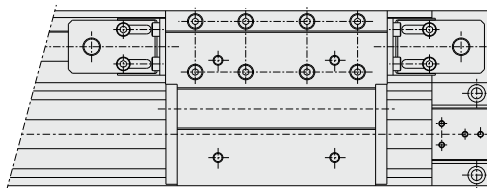

(mm)							
Model	H1	H2	L1	TL	W1	W2	W3
MY1H16□	39.2	33	0.5	5.6	18	16	10.4
MY1H20□	45.7	39.5	3	6	18	16	10.4
MY1H25□	53.5	46	3	11.5	29.3	27.3	17.7
MY1H32□	67	56	6.5	12	29.3	27.3	17.7
MY1H40□	83	68.5	10.5	16	38	35	24.4

Side Support

Side support A MY-S□A

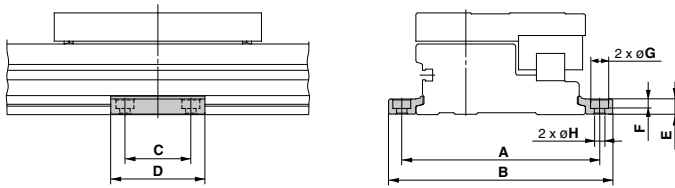

Side support B MY-S□B

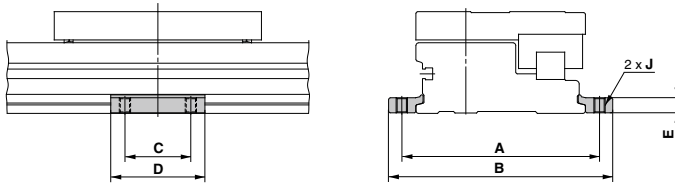

Model	Applicable bore size	A	B	C	D	E	F	G	H	J
MY-S10 ^ø ₆	MY1H10	53	61.6	12	21	3	1.2	6.5	3.4	M4 x 0.7
MY-S16 ^ø ₆	MY1H16	71	81.6	15	26	4.9	3	6.5	3.4	M4 x 0.7
MY-S20 ^ø ₆	MY1H20	91	103.6	25	38	6.4	4	8	4.5	M5 x 0.8
MY-S25 ^ø ₆	MY1H25	105	119	35	50	8	5	9.5	5.5	M6 x 1
MY-S32 ^ø ₆	MY1H32	130	148	45	64	11.7	6	11	6.6	M8 x 1.25
MY-S40 ^ø ₆	MY1H40	145	167	55	80	14.8	8.5	14	9	M10 x 1.5

* A set of side supports consists of a left support and a right support.

Guide for Side Support Application

For long stroke operation, the cylinder tube may be deflected depending on its own weight and the load mass. In such a case, use a side support in the middle section. The spacing (L) of the support must be no more than the values shown in the graph on the right.

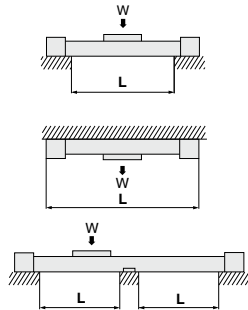

⚠ Caution

1. If the cylinder mounting surfaces are not measured accurately, using a side support may cause poor operation. Therefore, be sure to level the cylinder tube when mounting. Also, for long stroke operation involving vibration and impact, use of a side support is recommended even if the spacing value is within the allowable limits shown in the graph.
2. Support brackets are not for mounting; use them solely for providing support.

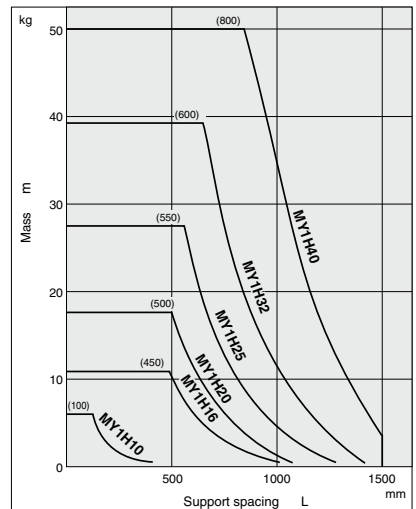

MY1B

-Z

MY1H

-Z

MY1B

MY1M

MY1C

MY1H

HT

MY1

□W

MY2C

MY2

□H

MY3A

MY3B

MY3M

□D

□X

Technical data

Technical data

Series MY1HT

High Rigidity/Linear Guide Type

ø50, ø63



The use of two linear guides allows a maximum load of 320 kg. (ø63)

Rodless cylinder
MY1BH

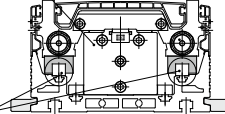

2 linear guides

Easy maintenance is stressed by a revolutionary construction which allows cylinder replacement without disturbing the guide units or workpiece.

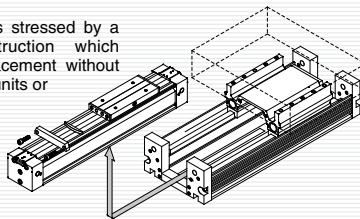

MY1B
-Z

MY1H
-Z

MY1B

MY1M

MY1C

MY1H

MY1
HT

MY1
□W

MY2C

MY2
H□

MY3A
MY3B

MY3M

D-□

-X□

Technical
data

Series MY1HT Prior to Use

Maximum Allowable Moment/Maximum Load Mass

Model	Bore size (mm)	Maximum allowable moment (N-m)			Maximum load mass (kg)		
		M ₁	M ₂	M ₃	m ₁	m ₂	m ₃
MY1HT	50	140	180	140	200	140	200
	63	240	300	240	320	220	320

The above values are the maximum allowable values for moment and load. Refer to each graph regarding the maximum allowable moment and maximum allowable load for a particular piston speed.

Maximum Allowable Moment

Select the moment from within the range of operating limits shown in the graphs. Note that the maximum allowable load value may sometimes be exceeded even within the operating limits shown in the graphs. Therefore, also check the allowable load for the selected conditions.

Load mass (kg)

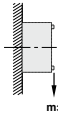

Moment (N-m)

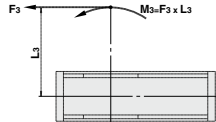
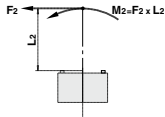
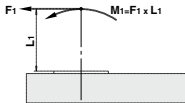

<Calculation of guide load factor>

- Maximum allowable load (1), static moment (2), and dynamic moment (3) (at the time of impact with stopper) must be examined for the selection calculations.
 * To evaluate, use \bar{v}_a (average speed) for (1) and (2), and v (collision speed $v = 1.4\bar{v}_a$) for (3). Calculate m_{max} for (1) from the maximum allowable load graph (m_1, m_2, m_3) and M_{max} for (2) and (3) from the maximum allowable moment graph (M_1, M_2, M_3).

Maximum Load Mass

Select the load from within the range of limits shown in the graphs. Note that the maximum allowable moment value may sometimes be exceeded even within the operating limits shown in the graphs. Therefore, also check the allowable moment for the selected conditions.

$$\text{Sum of guide load factors } \Sigma \alpha = \frac{\text{Load mass [m]}}{\text{Maximum allowable load [m max]}} + \frac{\text{Static moment [M]}^{(1)}}{\text{Allowable static moment [Mmax]}} + \frac{\text{Dynamic moment [Me]}^{(2)}}{\text{Allowable dynamic moment [MEmax]}} \leq 1$$

- Note 1) Moment caused by the load, etc., with cylinder in resting condition.
 Note 2) Moment caused by the impact load equivalent at the stroke end (at the time of impact with stopper).
 Note 3) Depending on the shape of the workpiece, multiple moments may occur. When this happens, the sum of the load factors ($\Sigma \alpha$) is the total of all such moments.

- Reference formula [Dynamic moment at impact]
 Use the following formulae to calculate dynamic moment when taking stopper impact into consideration.

- m:** Load mass (kg)
F: Load (N)
F_E: Load equivalent to impact (at impact with stopper) (N)
 \bar{v}_a : Average speed (mm/s)
M: Static moment (N-m)

$$v = 1.4\bar{v}_a \text{ (mm/s)} \quad F_E = 1.4\bar{v}_a \cdot \delta \cdot m \cdot g \quad (\text{Note 4})$$

$$\therefore M_E = \frac{1}{3} \cdot F_E \cdot L = 4.57\bar{v}_a \delta m L \quad (\text{Note 5})$$

- \bar{v} :** Collision speed (mm/s)
L: Distance to the load's center of gravity (m)
M_E: Dynamic moment (N-m)
 δ : Damper coefficient
 With rubber bumper = 4/100 (MY1B10, MY1H10)
 With air cushion = 1/100
 With shock absorber = 1/100
g: Gravitational acceleration (9.8 m/s²)

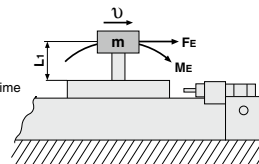

- Note 4) $1.4\bar{v}_a \delta$ is a dimensionless coefficient for calculating impact force.
 Note 5) Average load coefficient ($= \frac{1}{3}$): This coefficient is for averaging the maximum load moment at the time of stopper impact according to service life calculations.

- For detailed selection procedures, refer to pages 1310 and 1311.

MY1HT/M₁

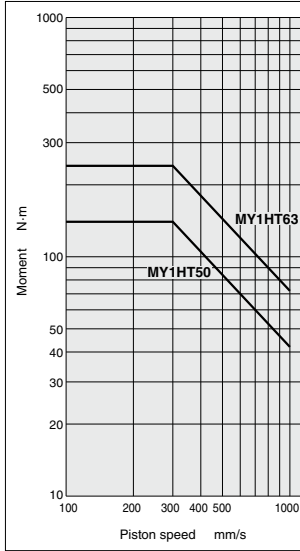

MY1HT/M₂

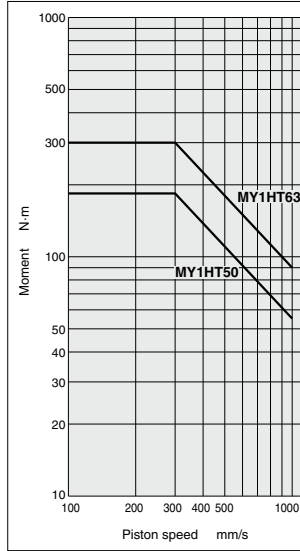

MY1HT/M₃

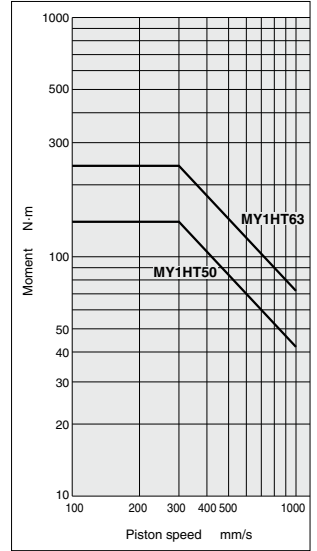

MY1HT/m₁

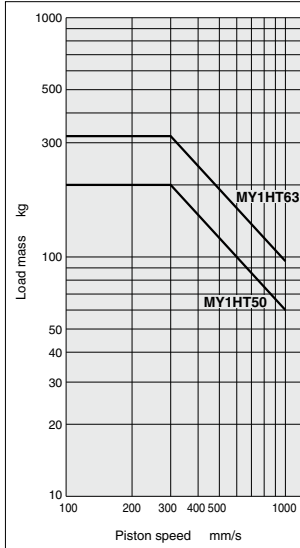

MY1HT/m₂

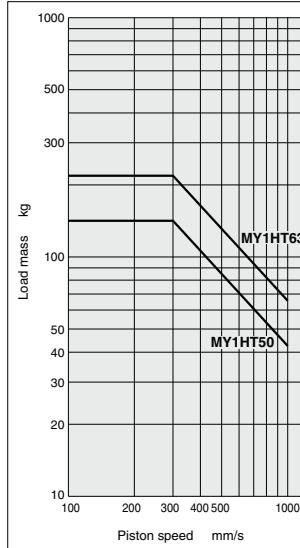

MY1HT/m₃

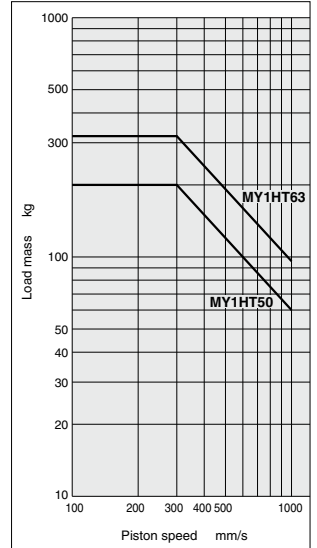

MY1B
-Z

MY1H
-Z

MY1B

MY1M

MY1C

MY1H

MY1
HT

MY1
W

MY2C

MY2
H

MY3A
MY3B

MY3M

D-

-X

Technical
data

Series MY1HT Model Selection

Following are the steps for selecting the most suitable Series MY1HT to your application.

Calculation of Guide Load Factor

1. Operating Conditions

Cylinder MY1HT50-600
 Average operating speed v_a ... 700 mm/s
 Mounting orientation Vertical mounting
 Cushion Shock absorber
 ($\delta = 1/100$)

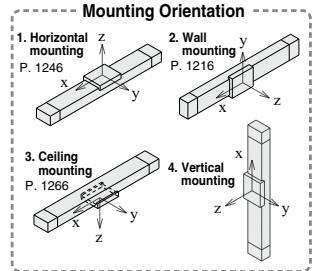
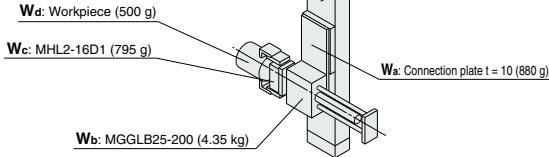

For actual examples of calculation for each orientation, refer to the pages above.

2. Load Blocking

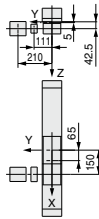

Mass and Center of Gravity for Each Workpiece

Workpiece no. W _n	Mass m _n	Center of gravity		
		X-axis X _n	Y-axis Y _n	Z-axis Z _n
W _a	0.88 kg	65 mm	0 mm	5 mm
W _b	4.35 kg	150 mm	0 mm	42.5 mm
W _c	0.795 kg	150 mm	111 mm	42.5 mm
W _d	0.5 kg	150 mm	210 mm	42.5 mm

n=a, b, c, d

3. Composite Center of Gravity Calculation

$$m_t = \sum m_n$$

$$= 0.88 + 4.35 + 0.795 + 0.5 = \mathbf{6.525 \text{ kg}}$$

$$X = \frac{1}{m_t} \times \sum (m_n \times x_n)$$

$$= \frac{1}{6.525} (0.88 \times 65 + 4.35 \times 150 + 0.795 \times 150 + 0.5 \times 150) = \mathbf{138.5 \text{ mm}}$$

$$Y = \frac{1}{m_t} \times \sum (m_n \times y_n)$$

$$= \frac{1}{6.525} (0.88 \times 0 + 4.35 \times 0 + 0.795 \times 111 + 0.5 \times 210) = \mathbf{29.6 \text{ mm}}$$

$$Z = \frac{1}{m_t} \times \sum (m_n \times z_n)$$

$$= \frac{1}{6.525} (0.88 \times 5 + 4.35 \times 42.5 + 0.795 \times 42.5 + 0.5 \times 42.5) = \mathbf{37.4 \text{ mm}}$$

4. Calculation of Load Factor for Static Load

m_t: Mass

m_t is the mass which can be transferred by the thrust, and as a rule, is actually

about 0.3 to 0.7 of the thrust. (This differs depending on the operating speed.)

M₁: Moment

M₁ max (from (1) of graph MY1HT/M₁) = 60 (N·m)

$$M_1 = m_t \times g \times Z = 6.525 \times 9.8 \times 37.4 \times 10^{-3} = 2.39 \text{ (N·m)}$$

$$\text{Load factor } \alpha_1 = M_1 / M_1 \text{ max} = 2.39 / 60 = \mathbf{0.04}$$

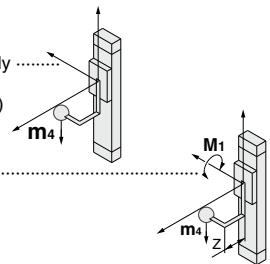

M₃ : Moment

M₃ max (from (2) of graph MY1HT/M₃) = 60 (N·m)

M₃ = m₄ × g × Y = 6.525 × 9.8 × 29.6 × 10⁻³ = 1.89 (N·m)

Load factor **α₂ = M₃/M₃ max** = 1.89/60 = **0.03**

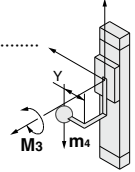

5. Calculation of Load Factor for Dynamic Moment

Equivalent load F_E at impact

F_E = 1.4U_a × δ × m × g = 1.4 × 700 × $\frac{1}{100}$ × 6.525 × 9.8 = 626.7 (N)

M_{1E} : Moment

M_{1E} max (from (3) of graph MY1HT/M₁ where 1.4U_a = 980 (mm/s) = 42.9 (N·m)

M_{1E} = $\frac{1}{3}$ × F_E × Z = $\frac{1}{3}$ × 626.7 × 37.4 × 10⁻³ = 7.82 (N·m)

Load factor **α₃ = M_{1E}/M_{1E} max** = 7.82/42.9 = **0.18**

M_{3E} : Moment

M_{3E} max (from (4) of graph MY1HT/M₃ where 1.4U_a = 980 (mm/s) = 42.9 (N·m)

M_{3E} = $\frac{1}{3}$ × F_E × Y = $\frac{1}{3}$ × 626.7 × 29.6 × 10⁻³ = 6.19 (N·m)

Load factor **α₄ = M_{3E}/M_{3E} max** = 6.19/42.9 = **0.14**

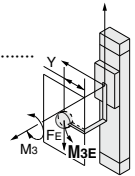
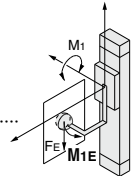

6. Sum and Examination of Guide Load Factors

Σα = α₁ + α₂ + α₃ + α₄ = 0.39 ≤ 1

The above calculation is within the allowable value, and therefore the selected model can be used.

Select a shock absorber separately.

In an actual calculation, when the total sum of guide load factors Σα in the formula above is more than 1, consider either decreasing the speed, increasing the bore size, or changing the product series.

This calculation can be easily made using the "SMC Pneumatics CAD System".

Allowable Moment

MY1HT/M₁

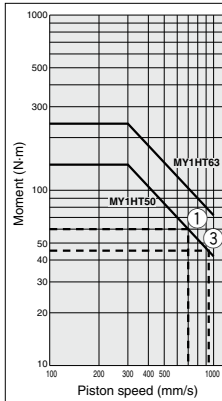

MY1HT/M₃

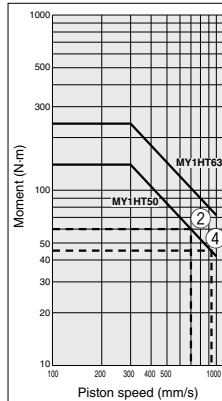

MY1B
-Z

MY1H
-Z

MY1B

MY1M

MY1C

MY1H

MY1
HT

MY1
□W

MY2C

MY2
□H

MY3A

MY3B

MY3M

D-□

-X□

Technical
data

Mechanically Jointed Rodless Cylinder High Rigidity/Linear Guide Type

Series MY1HT

ø50, ø63

How to Order

High Rigidity/
Linear Guide Type

MY1HT 50 [] [] - 400 L - Y7BW [] - []

High rigidity/Linear guide type*
(2 linear guides)

Bore size

50	50 mm
63	63 mm

Port thread type

Symbol	Type	Bore size
Nil	Rc	ø50, ø63
TN	NPT	
TF	G	

Piping

Nil	Standard type
G	Centralized piping type

Stroke

Refer to "Standard Stroke"
on page 1313.

Made to Order
Refer to page 1313
for details.

Number of
auto switches

Nil	2 pcs.
S	1 pc.
n	"n" pcs.

Auto switch

Nil Without auto switch (Built-in magnet)

* For the applicable auto switch model,
refer to the table below.

Stroke adjustment unit

L	One shock absorber at each stroke end
H	Two shock absorbers at each stroke end
LH	One shock absorber at left side, two shock absorbers at right side
HL	Two shock absorbers at left side, one shock absorber at right side

* The positions right and left are for when the label is on the
front side. Refer to the figure below for details.

Option

Stroke Adjustment Unit Part No.

Bore size (mm)	50	63
Unit type	MYT-A50L	MYT-A63L

Side Support Part No.

Type	Bore size (mm)	50	63
Side support A		MY-S63A	
Side support B		MY-S63B	

For details about dimensions, etc., refer to page 1318.

A set of side supports consists of a left support and a right support.

Two shock absorbers at left side

One shock absorber at right side

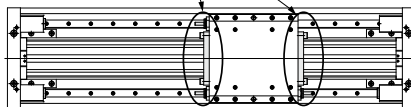

Note) With top cover removed

Label position

Applicable Auto Switches

Refer to pages 1559 to 1673 for further information on auto switches.

Type	Special function	Electrical entry	Indicator light	Wiring (Output)	Load voltage		Auto switch model		Lead wire length (m)			Pre-wired connector	Applicable load	
					DC	AC	Perpendicular	In-line	0.5 (Nil)	3 (L)	5 (Z)			
Solid state auto switch	—	Grommet	Yes	3-wire (NPN)	24 V	5 V, 12 V	—	Y69A	Y59A	●	●	○	IC circuit	
				3-wire (PNP)				Y7PV	Y7P	●	●	○		
	Diagnostic indication (2-color indication)			2-wire	5 V, 12 V	—	Y69B	Y59B	●	●	○	—		
				3-wire (NPN)			Y7NWX	Y7NW	●	●	○		IC circuit	
				3-wire (PNP)			Y7PWV	Y7PW	●	●	○			
Water resistant (2-color indication)	—	Grommet	No	2-wire	24 V	12 V	100 V or less	Y7BWX	Y7BW	●	●	○	—	
				—				Y7BA**	—	●	●	○		
				—				—	—	●	●	○		
Reed auto switch	—	Grommet	Yes	3-wire (NPN equivalent)	24 V	12 V	100 V or less	Z76	—	●	●	—	IC circuit	—
				2-wire				Z73	—	●	●	●	—	
Reed auto switch	—	Grommet	No	2-wire	24 V	12 V	100 V or less	Z80	—	●	●	—	IC circuit	Relay, PLC
				—				—	—	●	●	—		

** Water resistant type auto switches can be mounted on the above models, but in such case SMC cannot guarantee water resistance.

* Consult with SMC regarding water resistant types with the above model numbers.

* Lead wire length symbols: 0.5 m Nil (Example) Y7BW
3 m L (Example) Y7BWL
5 m Z (Example) Y7BWLZ

* Solid state auto switches marked with "○" are produced upon receipt of order.

* Separate switch spacers (BMP1-032) are required for retrofitting of auto switches.

* There are other applicable auto switches than listed above. For details, refer to page 1321.

* For details about auto switches with pre-wired connector, refer to pages 1626 and 1627.

* Auto switches are shipped together (not assembled). (For details about auto switch mounting, etc., refer to pages 1319 to 1321.)

Mechanically Jointed Rodless Cylinder High Rigidity/Linear Guide Type *Series MY1HT*

Specifications

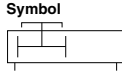

Bore size (mm)	50	63
Fluid	Air	
Action	Double acting	
Operating pressure range	0.1 to 0.8 MPa	
Proof pressure	1.2 MPa	
Ambient and fluid temperature	5 to 60°C	
Piston speed	100 to 1000 mm/s	
Cushion	Shock absorbers on both ends (Standard)	
Lubrication	Non-lube	
Stroke length tolerance	2700 or less ^{+1.8} / ₀ ⁸ , 2701 to 5000 ^{+2.8} / ₀ ⁸	
Port size	Side port	Rc 3/8

Note) Use at a speed within the absorption capacity range. Refer to page 1314.

Stroke Adjustment Unit Specifications

Applicable bore size (mm)	50		63	
Unit symbol, contents	L	H	L	H
	RB2015 and adjustment bolt: 1 set each	RB2015 and adjustment bolt: 2 sets each	RB2725 and adjustment bolt: 1 set each	RB2725 and adjustment bolt: 2 sets each
Fine stroke adjustment range (mm)	0 to -20		0 to -25	
Stroke adjustment range	For adjustment method, refer to page 1315.			

* Stroke adjustment range is applicable for one side when mounted on a cylinder.

Shock absorber model	RB2015 x 1 pc.	RB2015 x 2 pcs.	RB2725 x 1 pc.	RB2725 x 2 pcs.
Maximum energy absorption (J)	58.8	88.2 ^{Note)}	147	220.5 ^{Note)}
Stroke absorption (mm)	15	15	25	25
Maximum collision speed (mm/s)	1000		1000	
Maximum operating frequency (cycle/min)	25	25	10	10
Spring force (N)	Extended	8.34	16.68	8.83
	Retracted	20.50	41.00	20.01
Operating temperature range (°C)	5 to 60			

Note) Maximum energy absorption for 2 pcs. is calculated by multiplying the value for 1 pc. by 1.5.

* The shock absorber service life is different from that of the MY1HT cylinder depending on operating conditions. Refer to the RB Series Specific Product Precautions for the replacement period.

Theoretical Output

Bore size (mm)	Piston area (mm ²)	Operating pressure (MPa)						(N)
		0.2	0.3	0.4	0.5	0.6	0.7	
50	1962	392	588	784	981	1177	1373	1569
63	3115	623	934	1246	1557	1869	2180	2492

Note) Theoretical output (N) = Pressure (MPa) x Piston area (mm²)

Standard Stroke

Bore size (mm)	Standard stroke (mm) ^{Note)}	Maximum manufacturable stroke (mm)
50-63	200, 400, 600, 800, 1000, 1500, 2000	5000

Note) Cylinders other than the standard stroke type are manufactured upon request for special order.



Made to Order Specifications
(For details, refer to pages 1699 to 1818.)

Symbol	Specifications
-XC67	NBR rubber lining in dust seal band

Weight

Bore size (mm)	Basic weight	Additional weight per each 25 mm of stroke	Weight of moving parts	Side support weight (per set)	Stroke adjustment unit weight		
					Type A and B	L unit weight	LH unit weight
50	30.62	0.87	5.80	0.17	0.62	0.93	1.24
63	41.69	1.13	8.10	0.17	1.08	1.62	2.16

Calculation: (Example) **MY1HT50-400L**

- Basic weight30.62 kg
- Additional weight0.87/25 st
- L unit weight0.62 kg
- Cylinder stroke..... 400 st
- 30.62 + 0.87 x 400 + 25 + 0.62 x 2 = 45.8

MY1B
-Z

MY1H
-Z

MY1B

MY1M

MY1C

MY1H

MY1
HT

MY1
□W

MY2C

MY2
H□

MY3A

MY3B

MY3M

D-□

-X□

Technical
data

Cushion Capacity

Cushion Selection

<Stroke adjustment unit with built-in shock absorber>

L unit

Use this unit when the cylinder stroke is outside of the effective air cushion range even if the load and speed are within the air cushion limit line, or when the cylinder is operated in a load and speed range above the air cushion limit line or below the L unit limit line.

H unit

Use this unit when the cylinder is operated in a load and speed range above the L unit limit line and below the H unit limit line.

Stroke Adjustment Unit Absorption Capacity

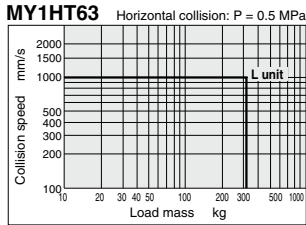
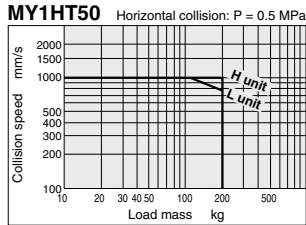

Stopper Bolt Holding Screw Tightening Torque

Stopper Bolt

Tightening Torque for Stroke Adjustment Unit Lock Plate Holding Bolts (N·m)

Bore size (mm)	Tightening torque
50	0.6
63	1.5

Calculation of Absorbed Energy for Stroke Adjustment Unit with Built-in Shock Absorber (N·m)

Type of impact	Horizontal collision	Vertical (Downward)	Vertical (Upward)
Kinetic energy E_1		$\frac{1}{2} m \cdot v^2$	
Thrust energy E_2	$F \cdot s$	$F \cdot s + m \cdot g \cdot s$	$F \cdot s - m \cdot g \cdot s$
Absorbed energy E		$E_1 + E_2$	

Symbol

v : Speed of impact object (m/s)

F : Cylinder thrust (N)

s : Shock absorber stroke (m)

m : Mass of impact object (kg)

g : Gravitational acceleration (9.8 m/s²)

Note) The speed of the impact object is measured at the time of impact with the shock absorber.

⚠ Precautions

Be sure to read before handling. Refer to front matter 57 for Safety Instructions and pages 3 to 12 for Actuator and Auto Switch Precautions.

Mounting

⚠ Caution

1. Do not put hands or fingers inside when the body is suspended.

Since the body is heavy, use eye bolts when suspending it.
(The eye bolts are not included with the body.)

Stroke Adjustment Method

Caution

- As shown in Figure (1), to adjust the stopper bolt within the adjustment range A, insert a hexagon wrench from the top to loosen the hexagon socket head set screw by approximately one turn, and then adjust the stopper bolt with a flat head screwdriver.
- When the adjustment described in 1 above is insufficient, the shock absorber can be adjusted. Remove the covers as shown in Figure (2) and make further adjustment by loosening the hexagon nut.
- Various dimensions are indicated in Table (1). Never make an adjustment that exceeds the dimensions in the table, as it may cause an accident and/or damage.

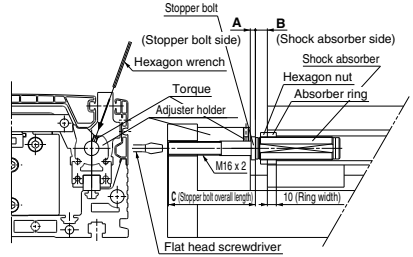

Figure (1) Stroke adjusting section detail

Table (1)

Bore size (mm)	50	63
A to A Max.	6 to 26	6 to 31
B to B Max.	14 to 54	14 to 74
C	87	102
Max. adjustment range	60	85

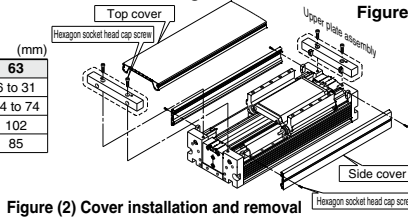

Figure (2) Cover installation and removal

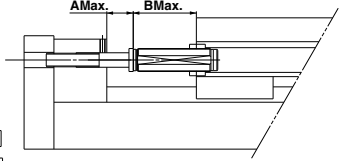

Figure (3) Maximum stroke adjustment detail

Disassembly and Assembly Procedure

Caution

Disassembly step

- Remove the hexagon socket head cap screws 1, and remove the upper plates.
- Remove the top cover.
- Remove the hexagon socket head cap screws 2, and remove the end covers and couplers.
- Remove the hexagon socket head cap screws 3.
- Remove the hexagon socket head cap screws 4, and remove the end supports.
- Remove the cylinder.

Assembly step

- Insert the MY1BH cylinder.
- Temporarily fasten the end supports with the hexagon socket head cap screws 4.
- With two hexagon socket head cap screws 3 on the L or R side, pull the end support and the cylinder.
- Tighten the hexagon socket head cap screws 3 on the other side to eliminate the looseness in the axial direction. (At this point, a space is created between the end support and the end plate on one side, but this is not a problem.)
- Re-tighten the hexagon socket head cap screws 4.
- Fasten the end cover with the hexagon head cap screws 2, while making sure that the coupler is in the right direction.
- Place the top cover on the body.
- Insert the holding blocks into the top cover and fasten the upper plates with the hexagon socket head cap screws 1.

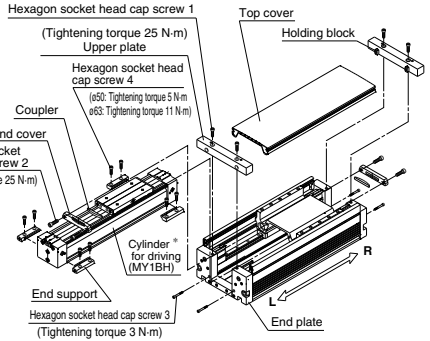

*** Cylinder For Driving (Series MY1BH)**

Since Series MY1BH is a cylinder for driving for Series MY1HT, its construction is different from Series MY1B. Do not use Series MY1B as a cylinder for driving, since it will lead to damage.

How to Order High rigidity/Linear guide type **MY1HT** 50 □ □ - 300 L - Z73 □

Cylinder for driving **MY1BH** 50 □ □ - 300

Bore size

50	50 mm
63	63 mm

Port thread type

Symbol	Type	Bore size
Nil	Rc	ø50, ø63
TN	NPT	
TF	G	

Piping

Nil	Standard type
G	Centralized piping type

Stroke (mm)

MY1B

-Z

MY1H

-Z

MY1B

MY1M

MY1C

MY1H

MY1 HT

MY1

□W

MY2C

MY2

□H

MY3A

MY3B

MY3M

D-□

-X□

Technical data

Series MY1HT

Construction

Standard type

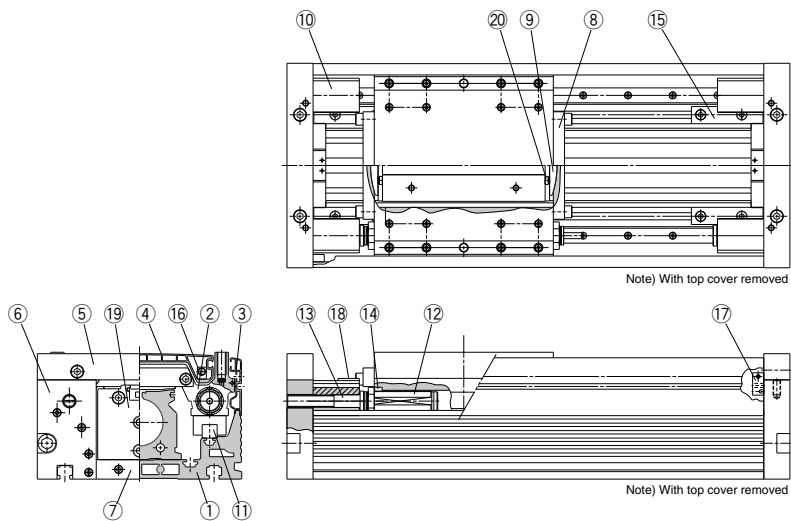

Component Parts

No.	Description	Material	Note
1	Guide frame	Aluminum alloy	Hard anodized
2	Slide table	Aluminum alloy	Hard anodized
3	Side cover	Aluminum alloy	Hard anodized
4	Top cover	Aluminum alloy	Hard anodized
5	Upper plate	Aluminum alloy	Hard anodized
6	End plate	Aluminum alloy	Hard anodized
7	Bottom plate	Aluminum alloy	Hard anodized
8	End cover	Aluminum alloy	Chromated
9	Coupler	Aluminum alloy	Chromated
10	Adjuster holder	Aluminum alloy	Hard anodized
11	Guide	—	
12	Shock absorber	—	
13	Stopper bolt	Carbon steel	Nickel plated
14	Absorber ring	Rolled steel	Nickel plated
15	End support	Aluminum alloy	Hard anodized
16	Top block	Aluminum alloy	Chromated
17	Side block	Aluminum alloy	Chromated
18	Slide plate	Special resin	
19	Rodless cylinder	—	MY1BH
20	Stopper	Carbon steel	Nickel plated

Mechanically Jointed Rodless Cylinder High Rigidity/Linear Guide Type *Series MY1HT*

Standard Type/Centralized Piping Type $\varnothing 50, \varnothing 63$

Refer to page 1325 regarding centralized piping port variations.

MY1HT50□/63□ — **Stroke**

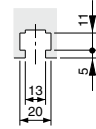
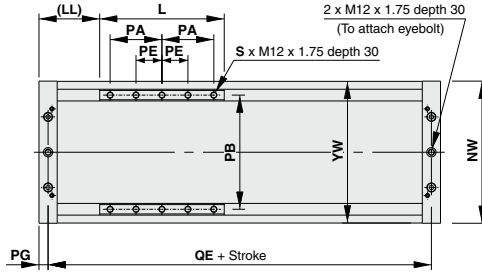

Applicable nut JIS B 1163
Square nut M12

Dimensions of T-slot for mounting

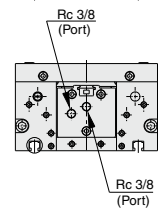
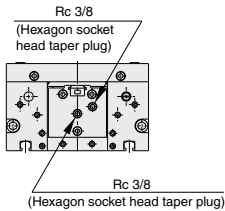
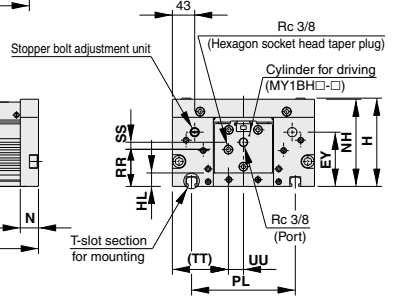
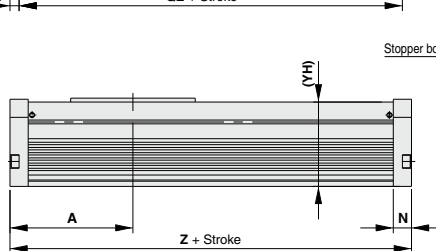
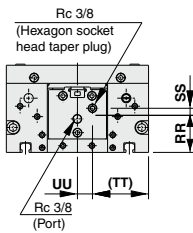

MY1HT□G

MY1HT□G

Model	A	EY	H	HL	L	LL	N	NH	NW	PA	PB	PE	PG
MY1HT50□	207	97.5	145	23	210	102	30	143	254	90	200	-	15
MY1HT63□	237	104.5	170	26	240	117	35	168	274	100	220	50	17.5

Model	PL	QE	RR	S	SS	TT	UU	YH	YW	Z
MY1HT50□	180	384	57	6	10	103.5	23.5	136.4	253	414
MY1HT63□	200	439	71.5	10	13.5	108	29	162.6	273	474

MY1B

-Z

MY1H

-Z

MY1B

MY1M

MY1C

MY1H

MY1HT

MY1

□W

MY2C

MY2

H□

MY3A

MY3B

MY3M

MY3M

MY3M

MY3M

MY3M

MY3M

MY3M

MY3M

MY3M

MY3M

MY3M

MY3M

MY3M

MY3M

MY3M

MY3M

MY3M

MY3M

MY3M

MY3M

MY3M

MY3M

MY3M

MY3M

MY3M

MY3M

MY3M

MY3M

MY3M

MY3M

MY3M

MY3M

MY3M

Series MY1HT

Side Support

Side support A MY-S63A

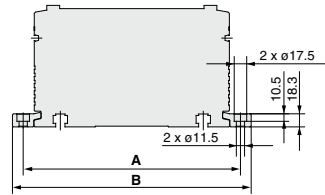
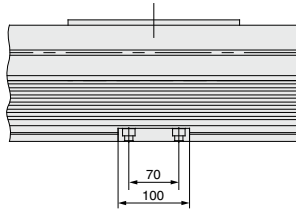

Side support B MY-S63B

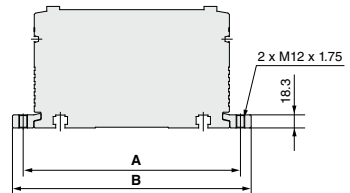
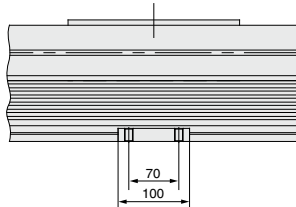

Dimensions

Model	Applicable bore size	(mm)	
		A	B
MY-S63 ^A _B	MY1HT50	284	314
	MY1HT63	304	334

* A set of side supports consists of a left support and a right support.

Guide for Side Support Application

For long stroke operation, the cylinder tube may be deflected depending on its own weight and the load mass. In such a case, use a side support in the middle section. The spacing (L) of the support must be no more than the values shown in the graph on the right.

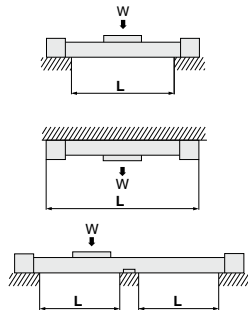

⚠ Caution

1. If the cylinder mounting surfaces are not measured accurately, using a side support may cause poor operation. Therefore, be sure to level the cylinder tube when mounting. Also, for long stroke operation involving vibration and impact, use of a side support is recommended even if the spacing value is within the allowable limits shown in the graph.
2. Support brackets are not for mounting; use them solely for providing support.

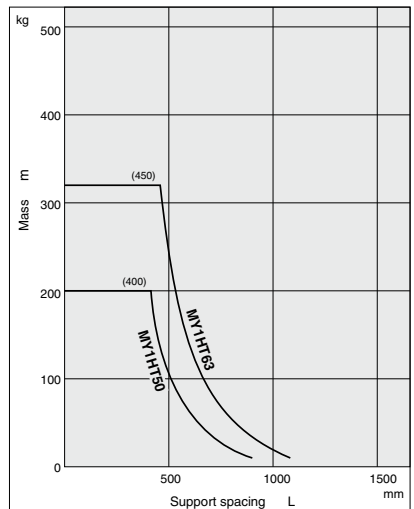

Series MY1

Auto Switch Mounting 1

Proper Auto Switch Mounting Position (Detection at stroke end)

MY1B (Basic type)

ø10, ø16, ø20

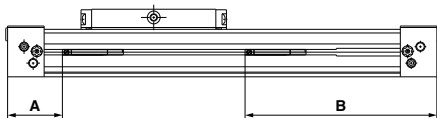

ø25 to ø100

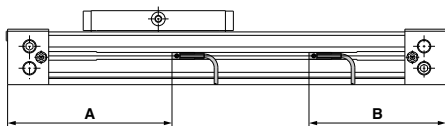

MY1M (Slide bearing guide type)

ø16, ø20

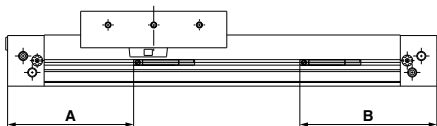

ø25 to ø63

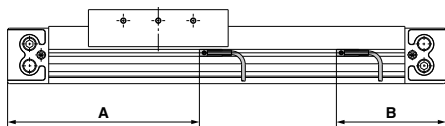

MY1C (Cam follower guide type)

ø16, ø20

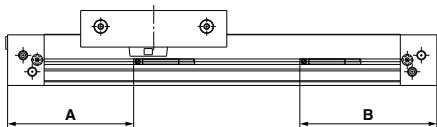

ø25 to ø63

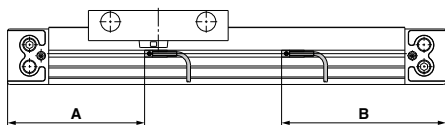

Proper Auto Switch Mounting Position (mm)

Auto switch model	D-M9□ D-M9□V D-M9□W D-M9□WV D-M9□A D-M9□AV		D-A9□ D-A9□V		D-Y59□/Y7P D-Y69□/Y7PV D-Y7□W D-Y7□WV D-Y7BA D-Z7□/Z80	
	A	B	A	B	A	B
Bore size						
10	24	86	20	90	—	—
16	31.5	128.5	27.5	132.5	—	—
20	39	161	35	165	—	—
25	136.5	83.5	—	—	131.5	88.5
32	185	95	—	—	180	100
40	221	119	—	—	216	124
50	—	—	—	—	272.5	127.5
63	322.5	137.5	—	—	317.5	142.5
80	489.5	200.5	—	—	484.5	205.5
100	574.5	225.5	—	—	569.5	230.5

Note 1) D-M9□□□ type cannot be mounted on ø50.

Note 2) Adjust the auto switch after confirming the operating condition in the actual setting.

Proper Auto Switch Mounting Position (mm)

Auto switch model	D-M9□ D-M9□V D-M9□W D-M9□WV D-M9□A D-M9□AV		D-A9□ D-A9□V		D-Y59□/Y7P D-Y69□/Y7PV D-Y7□W D-Y7□WV D-Z7□/Z80	
	A	B	A	B	A	B
Bore size						
16	74	86	70	90	—	—
20	94	106	90	110	—	—
25	143.5	75.5	—	—	139.5	80.5
32	189.5	90.5	—	—	184.5	95.5
40	234.5	105.5	—	—	229.5	110.5
50	283.5	116.5	—	—	278.5	121.5
63	328.5	131.5	—	—	323.5	136.5

Note) Adjust the auto switch after confirming the operating condition in the actual setting.

Proper Auto Switch Mounting Position (mm)

Auto switch model	D-M9□ D-M9□V D-M9□W D-M9□WV D-M9□A D-M9□AV		D-A9□ D-A9□V		D-Y59□/Y7P D-Y69□/Y7PV D-Y7□W D-Y7□WV D-Z7□/Z80	
	A	B	A	B	A	B
Bore size						
16	74	86	70	90	—	—
20	94	106	90	110	—	—
25	102	118	—	—	97	123
32	132	148	—	—	127	153
40	162.5	175.5	—	—	157.5	182.5
50	283.5	116.5	—	—	278.5	121.5
63	328.5	131.5	—	—	323.5	136.5

Note) Adjust the auto switch after confirming the operating condition in the actual setting.

MY1B

-Z

MY1H

-Z

MY1B

MY1M

MY1C

MY1H

MY1 HT

MY1 □W

MY2C

MY2 H□

MY3A

MY3B

MY3M

D-□

-X□

Technical data

Series MY1

Auto Switch Mounting 2

Proper Auto Switch Mounting Position (Detection at stroke end)

MY1H (Linear guide type)

ø10, ø16, ø20

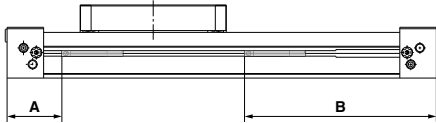

ø25 to ø40

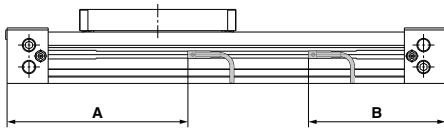

Proper Auto Switch Mounting Position (mm)

Auto switch model	D-M9□ D-M9□V D-M9□W D-M9□WV D-M9□A D-M9□AV		D-A9□ D-A9□V		D-Y59□/Y7P D-Y69□/Y7PV D-Y7□W D-Y7□WV D-Z7□/Z80	
	A	B	A	B	A	B
Bore size						
10	24	86	20	90	—	—
16	31.5	128.5	27.5	132.5	—	—
20	39	161	35	165	—	—
25	136.5	83.5	132.5	87.5	131.5	88.5
32	185	94	181	99	180	100
40	231	119	217	123	216	124

Note) Adjust the auto switch after confirming the operating condition in the actual setting.

MY1HT (High rigidity/Linear guide type)

ø50, ø63

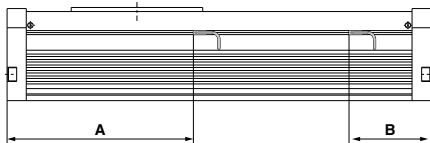

Proper Auto Switch Mounting Position (mm)

Auto switch model	D-Y59□/Y7P D-Y69□/Y7PV D-Y7□W D-Y7□WV D-Y7BA D-Z7□/Z80	
	A	B
Bore size		
50	290.5	123.5
63	335.5	138.5

Note) Adjust the auto switch after confirming the operating condition in the actual setting.

How to Mount the Auto Switch (For MY1HT)

When attaching an auto switch, first take a switch spacer between your fingers and press it into a switch mounting groove. When doing this, confirm that it is set in the correct mounting orientation, or reattach if necessary.

Next, insert an auto switch into the groove and slide it until it is positioned under the switch spacer.

After establishing the mounting position, use a watchmaker's flat head screwdriver to tighten the auto switch mounting screw which is included.

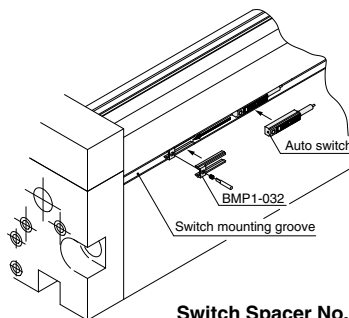
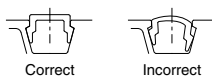

Note) When tightening an auto switch mounting screw, use a watchmaker's screwdriver with a grip diameter of 5 to 6 mm. Also, tighten with a torque of about 0.05 to 0.1 N·m. As a guide, it should be turned about 90° past the point at which tightening can be felt.

Switch Spacer No.

Cylinder series	Applicable bore size (mm)	
	50	63
MY1HT	BMP1-032	

Operating Range

(Note) Since this is a guideline including hysteresis, not meant to be guaranteed. (Assuming approximately ±30% dispersion.)
There may be the case it will vary substantially depending on an ambient environment.

MY1B (Basic type) (mm)

Auto switch model	Bore size									
	10	16	20	25	32	40	50	63	80	100
D-A9□/A9□V	6	6.5	8.5	—	—	—	—	—	—	—
D-M9□/M9□V D-M9□W/M9□WV D-M9□A/M9□AV	3.5	4	5.5	5.5	7	8.5	—	12	12	11.5
D-Z7□/Z80	—	—	—	8.5	11.5	11.5	11.5	11.5	11.5	11.5
D-Y59□/Y69□ D-Y7P/Y7PV D-Y7□W/Y7□WV	—	—	—	6	9	10	3.5	3.5	3.5	3.5

D-M9□□ type cannot be mounted on ø50.

MY1M (Slide bearing guide type) (mm)

Auto switch model	Bore size						
	16	20	25	32	40	50	63
D-A9□/A9□V	11	7.5	—	—	—	—	—
D-M9□/M9□V D-M9□W/M9□WV D-M9□A/M9□AV	7.5	7.5	8.5	8.5	9.5	7	6
D-Z7□/Z80	—	—	12	12	12	11.5	11.5
D-Y59□/Y69□ D-Y7P/Y7PV D-Y7□W/Y7□WV	—	—	5	5	5	5.5	5.5

MY1C (Cam follower guide type) (mm)

Auto switch model	Bore size						
	16	20	25	32	40	50	63
D-A9□/A9□V	11	7.5	—	—	—	—	—
D-M9□/M9□V D-M9□W/M9□WV D-M9□A/M9□AV	7.5	7.5	7	8	8.5	7	6
D-Z7□/Z80	—	—	12	12	12	11.5	11.5
D-Y59□/Y69□ D-Y7P/Y7PV D-Y7□W/Y7□WV	—	—	5	5	5	5.5	5.5

MY1H (Linear guide type) (mm)

Auto switch model	Bore size					
	10	16	20	25	32	40
D-A9□/A9□V	11	6.5	8.5	7.5	10	10
D-M9□/M9□V D-M9□W/M9□WV D-M9□A/M9□AV	3	4.5	5	5.5	6	6.5
D-Z7□/Z80	—	—	—	8.5	11.5	11.5
D-Y59□/Y69□ D-Y7P/Y7PV D-Y7□W/Y7□WV	—	—	—	6	9	10

MY1HT

(High rigidity/Linear guide type) (mm)

Auto switch model	Bore size	
	50	63
D-Z7□/Z80	11	11
D-Y59□/Y69□ D-Y7P/Y7PV D-Y7□W/Y7□WV D-Y7BA	5	5

MY1B
-Z

MY1H
-Z

MY1B

MY1M

MY1C

MY1H

MY1
HT

MY1
□W

MY2C

MY2
H□

MY3A

MY3B

MY3M

Switch Mounting Bracket: Part No.

Auto switch model	Bore size (mm)	
	ø10, ø16, ø20	ø25 to ø63
D-A9□/A9□V D-M9□/M9□V D-M9□W/M9□WV D-M9□A/M9□AV	—	BMG2-012

Note1) MY1B/MY1C/MY1M, D-A9□ type cannot be mounted on ø25 to ø100 of Series MY1. D-M9□□ type cannot be mounted on ø50 of Series MY1B.

ø25 to ø63: M9□(V)/M9□W(V)/M9□A(V)

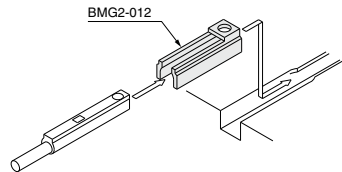

Besides the models listed in How to Order, the following auto switches are applicable.
Refer to pages 1559 to 1673 for the detailed specifications.

Auto switch type	Part no.	Electrical entry (Fetching direction)	Features	Applicable bore size
Solid state	D-Y69A, Y69B, Y7PV	Grommet (Perpendicular)	—	ø25 to ø100
	D-Y7N WV, Y7P WV, Y7B WV		Diagnostic indication (2-color indication)	
	D-Y59A, Y59B, Y7P	Grommet (In-line)	—	
	D-Y7N WV, Y7P WV, Y7B WV		Diagnostic indication (2-color indication)	

* For solid state auto switches, auto switches with a pre-wired connector are also available. Refer to pages 1626 and 1627 for details.
* Normally closed (NC = b contact) solid state auto switches (D-F9G/F9H/Y7G/Y7H types) are also available. Refer to pages 1577 and 1579 for details.

D-□

-X□

Technical
data

Series MY1

Made to Order: Individual Specifications

Please contact SMC for detailed dimensions, specifications, and lead times.



1 Helical Insert Thread Specifications

Symbol

-X168

Helical insert thread is used for the slide table mounting thread, the thread size is the same as the standard model.

MY1 **B** **Bore size** - **Stroke** - **Auto switch** **Suffix** -X168

Series: Bore size

Series	Bore size	10	16	20	25	32	40	50	63	80	100
B	Basic type	●	●	●	●	●	●	●	●	●	●
M	Slide bearing guide type	●	●	●	●	●	●	●	●	●	●
C	Cam follower guide type	●	●	●	●	●	●	●	●	●	●
H	Linear guide type	●	●	●	●	●	●	●	●	●	●
HT	High rigidity/Linear guide type	●	●	●	●	●	●	●	●	●	●

● indicates available by special order.

Example) MY1B40G-300L-Z73-X168



Series MY1

Specific Product Precautions 1

Be sure to read before handling.

Refer to front matter 57 for Safety Instructions and pages 3 to 12 for Actuator and Auto Switch Precautions.

Selection

⚠ Caution

1. When using a cylinder with long strokes, implement an intermediate support.

When using a cylinder with long strokes, implement an intermediate support to prevent the tube from sagging and being deflected by vibration or an external load.

Refer to the Guide for Side Support Application on pages 1239, 1261, 1281, 1305 and 1318.

2. For intermediate stops, use a dual-side pressure control circuit.

Since the mechanically jointed rodless cylinders have a unique seal structure, slight external leakage may occur. Controlling intermediate stops with a 3 position valve cannot hold the stopping position of the slide table (slider). The speed at the restarting state also may not be controllable. Use the dual-side pressure control circuit with a PAB-connected 3 position valve for intermediate stops.

3. Constant speed.

Since the mechanically jointed rodless cylinders have a unique seal structure, a slight speed change may occur. For applications that require constant speed, select an applicable equipment for the level of demand.

4. Load factor of 0.5 or less

When the load factor is high against the cylinder output, it may adversely affect the cylinder (condensation, etc.) and cause malfunctions. Select a cylinder to make the load factor less than 0.5. (Mainly when using an external guide)

5. Cautions on less frequent operation

When the cylinder is used extremely infrequently, operation may be interrupted in order for anchoring and a change lubrication to be performed or service life may be reduced.

6. Consider uncalculated loads such as piping, cableveyor, etc., when selecting a load moment

Calculation does not include the external acting force of piping, cableveyor, etc. Select load factors taking into account the external acting force of piping, cableveyor, etc.

7. Accuracy

The mechanical jointed rodless cylinder does not guarantee traveling parallelism. When accuracy in traveling parallelism and a middle position of stroke is required, please consult SMC.

Mounting

⚠ Caution

1. Do not apply strong impacts or excessive moment to the slide table (slider).

- The slide table (slider) is supported by precision bearings (MY1C, MY1H) or resin bearings. Therefore, do not apply strong impacts or excessive moment, etc., when mounting workpieces.

Mounting

⚠ Caution

2. When connecting to a load which has an external guide mechanism, use a discrepancy absorption mechanism.

- Mechanically jointed rodless cylinders can be used with a direct load within the allowable range for each type of guide. Please note that careful alignment is necessary when connecting to a load having an external guide mechanism. Mount the external guide mounting brackets and floating brackets in a place where the required degree of freedom for the floating Y and Z axes can be secured.

The thrust transmission area of the floating bracket must be fixed so that it does not partially contact the body.

- * Refer to the Coordinates and Moment in Model Selection on page 1215 for the details of floating Y and Z axes.

3. Do not mount cylinders as they are twisted.

When mounting, be sure for a cylinder tube not to be twisted. The flatness of the mounting surface is not appropriate, the cylinder tube is twisted, which may cause air leakage due to the detachment of a seal belt, damage a dust seal band, and cause malfunctions.

4. Do not mount a slide table on the fixed equipment surface.

It may cause damage or malfunctions since an excessive load is applied to the bearing.

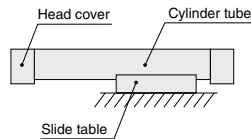

Mounting with a slide table (slider)

5. Consult SMC when mounting in a cantilevered way.

Since the cylinder body deflects, it may cause malfunctions. Please consult SMC when using it this way.

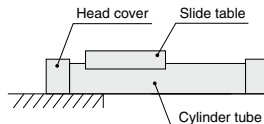

Mounting in a cantilevered way

6. Fixed parts of the cylinder on both ends must have at least 5 mm of contact between where the bottom of the cylinder tube and the equipment surface.

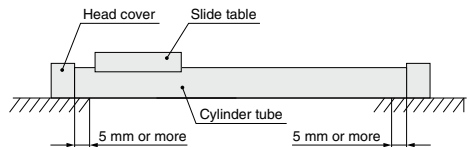

MY1B
-Z

MY1H
-Z

MY1B

MY1M

MY1C

MY1H

MY1
HT

MY1
□W

MY2C

MY2
H□

MY3A
MY3B

MY3M

D-□

-X□

Technical
data



Series MY1

Specific Product Precautions 2

Be sure to read before handling.

Refer to front matter 57 for Safety Instructions and pages 3 to 12 for Actuator and Auto Switch Precautions.

Mounting

Caution

7. Do not generate negative pressure in the cylinder tube.

Take precautions under operating conditions in which negative pressure is generated inside the cylinder by external forces or inertial forces. Air leakage may occur due to separation of the seal belt. Do not generate negative pressure in the cylinder by forcibly moving it with an external force during the trial operation or dropping it with self-weight under the non-pressure state, etc. When the negative pressure is generated, slowly move the cylinder by hand and move the stroke back and forth. After doing so, if air leakage still occurs, please consult SMC.

Handling

Caution

1. Do not unnecessarily alter the guide adjustment setting.

- The adjustment of the guide is preset and does not require readjustment under normal operating conditions. Therefore, do not unnecessarily alter the guide adjustment setting. However, series other than the MY1H Series can be readjusted and their bearings can be replaced.

To perform these operations, refer to the bearing replacement procedure given in the instruction manual.

2. Do not get your hands caught during cylinder operation.

For the cylinder with a stroke adjustment unit, the space between the slide table and stroke adjustment unit is very small, and your hands may get caught. When operating without a protective cover, be careful not to get your hands caught.

3. Avoid operation that causes negative pressure inside the cylinder.

Take precautions under operating conditions in which negative pressure is increased inside the cylinder by external forces or inertial forces. Air leakage may occur due to separation of the seal belt.

Operating Environment

Warning

1. Do not use in an environment where the cylinder is exposed to coolant, cutting oil, water drops, adhesive foreign particles, dust, etc. and avoid use with compressed air containing drainage and foreign particles.

- Foreign matter or liquids on the cylinder's interior or exterior can wash out the lubricating grease, which can lead to deterioration and damage of dust seal band and seal materials, causing a danger of malfunction.

When operating in locations with exposure to water and oil, or in dusty locations, provide protection such as a cover to prevent direct contact with the cylinder, or mount so that the dust seal band surface faces downward, and operate with clean compressed air.

2. Carry out cleaning and grease application suitable for the operating environment.

Carry out cleaning regularly when using in an operating environment in which the product is likely to get dirty. After cleaning, be sure to apply grease to the top side of the cylinder tube and the rotating part of the dust seal band. Apply grease to these parts regularly even if not after cleaning. Please consult SMC for the cleaning of the slide table (slider) interior and grease application.

Service Life and Replacement Period of Shock Absorber

Caution

1. Allowable operating cycle under the specifications set in this catalog is shown below.

1.2 million times RB08□□

2 million times RB10□□ to RB2725

Note) Specified service life (suitable replacement period) is the value at room temperature (20 to 25°C). The period may vary depending on the temperature and other conditions. In some cases the absorber may need to be replaced before the allowable operating cycle above.



Series MY1 Specific Product Precautions 3

Be sure to read before handling.
Refer to front matter 57 for Safety Instructions and pages 3 to 12 for Actuator and Auto Switch Precautions.

⚠ Caution

Centralized Piping Port Variations

- Head cover piping connection can be freely selected to best suit different piping conditions.

Applicable bore size	Port variations
<p>MY1B10 MY1H10</p> <p>Note 1) These ports are not applicable to MY1H10.</p>	<p style="text-align: center;">Slide table operating direction</p>
<p>MY1B16 to 100 MY1M16 to 63 MY1C16 to 63 MY1H16 to 40</p> <p>Note 2) For bottom piping, refer to the figure above.</p>	<p style="text-align: center;">Slide table operating direction</p>
<p>MY1HT50/63</p>	<p style="text-align: center;">Slide table operating direction</p>

MY1B
-Z

MY1H
-Z

MY1B

MY1M

MY1C

MY1H

MY1
HT

MY1
□W

MY2C

MY2
H□

MY3A
MY3B

MY3M

D-□

-X□

Technical
data